

ENGLISH

ENGLISH

IMPORTANT SAFETY INSTRUCTIONS

Putting sewing systems into operation is prohibited until it has been ascertained that the sewing systems in which these sewing machines will be built into, have conformed with the safety regulations in your country. Technical service for those sewing systems is also prohibited.

1. Observe the basic safety measures, including, but not limited to the following ones, whenever you use the machine.
2. Read all the instructions, including, but not limited to this Instruction Manual before you use the machine. In addition, keep this Instruction Manual so that you may read it at anytime when necessary.
3. Use the machine after it has been ascertained that it conforms with safety rules/standards valid in your country.
4. All safety devices must be in position when the machine is ready for work or in operation. The operation without the specified safety devices is not allowed.
5. This machine shall be operated by appropriately-trained operators.
6. For your personal protection, we recommend that you wear safety glasses.
7. For the following, turn off the power switch or disconnect the power plug of the machine from the receptacle.
 - 7-1 For threading needle(s), looper, spreader etc. and replacing bobbin.
 - 7-2 For replacing part(s) of needle, presser foot, throat plate, looper, spreader, feed dog, needle guard, folder, cloth guide etc.
 - 7-3 For repair work.
 - 7-4 When leaving the working place or when the working place is unattended.
 - 7-5 When using clutch motors without applying brake, it has to be waited until the motor stopped totally.
8. If you should allow oil, grease, etc. used with the machine and devices to come in contact with your eyes or skin or swallow any of such liquid by mistake, immediately wash the contacted areas and consult a medical doctor.

9. Tampering with the live parts and devices, regardless of whether the machine is powered, is prohibited.
10. Repair, remodeling and adjustment works must only be done by appropriately trained technicians or specially skilled personnel. Only spare parts designated by JUKI can be used for repairs.
11. General maintenance and inspection works have to be done by appropriately trained personnel.
12. Repair and maintenance works of electrical components shall be conducted by qualified electric technicians or under the audit and guidance of specially skilled personnel.

Whenever you find a failure of any of electrical components, immediately stop the machine.
13. Before making repair and maintenance works on the machine equipped with pneumatic parts such as an air cylinder, the air compressor has to be detached from the machine and the compressed air supply has to be cut off. Existing residual air pressure after disconnecting the air compressor from the machine has to be expelled. Exceptions to this are only adjustments and performance checks done by appropriately trained technicians or specially skilled personnel.
14. Periodically clean the machine throughout the period of use.

15. Grounding the machine is always necessary for the normal operation of the machine. The machine has to be operated in an environment that is free from strong noise sources such as high-frequency welder.
16. An appropriate power plug has to be attached to the machine by electric technicians. Power plug has to be connected to a grounded receptacle.

17. The machine is only allowed to be used for the purpose intended. Other used are not allowed.
18. Remodel or modify the machine in accordance with the safety rules/standards while taking all the effective safety measures. JUKI assumes no responsibility for damage caused by remodeling or modification of the machine.

19. Warning hints are marked with the two shown symbols.



Danger of injury to operator or service staff



items requiring special attention

FOR SAFE OPERATION



1. To avoid electric shock hazards, neither touch the motor or the button feeder, nor open the control box cover, and nor touch components mounted inside the control box while the power switch is turned ON.
2. Use the machine under the correct voltage setting.



1. To avoid personal injuries, exercise care not to allow your fingers, etc. to be caught in the button carrier acting to supply buttons during operating the machine.
2. Do not use the buttons other than those specified in the specifications of this machine.
3. Be sure to use the button carrier and the pattern suitable for the buttons to be used.
4. After changing the shape of button, the pattern or enlargement/reduction of the sewing size, make sure of the needle entry point without fail.
5. Do not turn OFF the power switch in a state that the needle is lowered. Wiper may break the needle.
6. So as to prevent possible accidents caused by abrupt start of the sewing machine, depress the pedal after ascertaining that there is no interfering thing under the needle when winding the bobbin thread.
7. Use the feed plate suitable for the buttons to be used.
8. When tilting the sewing machine, make sure that the button carrier is located at the origin position (the position where the button position is determined.). If not, turn spinner oscillating arm motor knob ① until the carrier is brought to its origin.

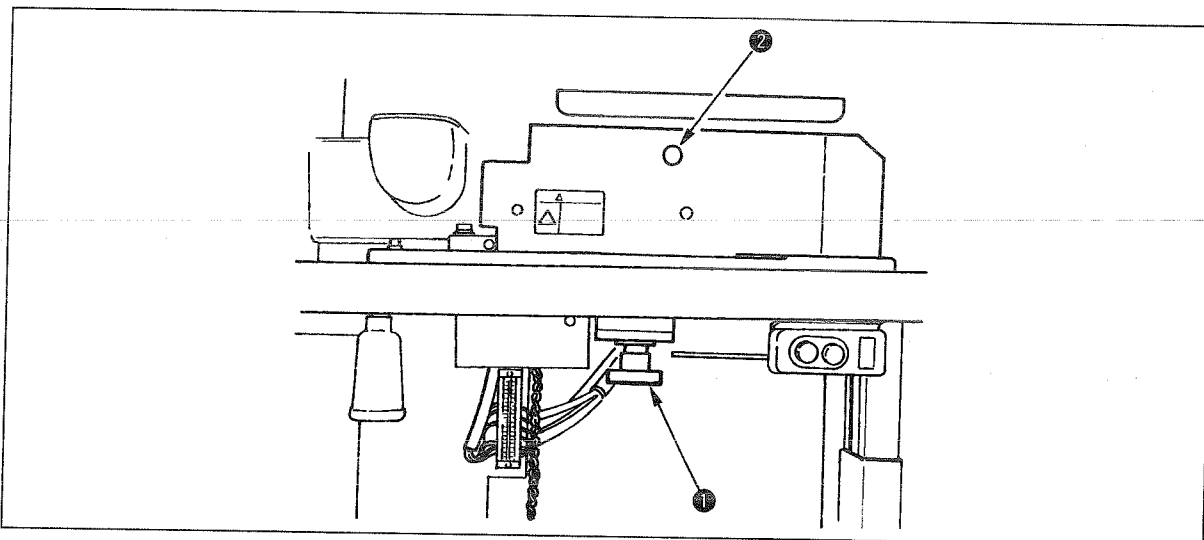

9. When Error "4" indicating an occurrence of a spinner oscillating arm failure or Error "5" indicating an occurrence of an index unit failure is given, the reset switch will be inoperative in order to protect the mechanical components. In this case, turn OFF the power to the machine once, and then re-turn ON the power.
10. This machine is equipped with the continuous cycle sewing feature. When you keep depressing the pedal, therefore, the buttons will be continuously fed from the button feeder. So, be careful.
11. If tightening too firmly screws of such components as the feed plate and the adjusting plate which are made of resin, the resin breakage may occur. So, be careful.
12. Apply grease on the worm gear and cam periodically (every six months).
13. The work attachment comes in two different types, the standard type and the large-button type (separate order). Whenever you have replaced the work attachment, be sure to adjust the fine positioning completion switch. (Refer to page 61.)
14. If a button clogs in the index unit, turn first manual spinner oscillating shaft ② counterclockwise using a slit screwdriver until it is released.
15. Sensitivity of the button feeder is very delicate, so be sure to adjust it carefully.
16. Connect the connectors while checking the correct direction of the respective connectors.
17. When the operation panel is installed on the top surface of the table, pass the cable of the operation panel to the rear face of the table through the table hole where BR device cable is wired.

CONTENTS

I. SPECIFICATIONS	1
1. Specifications	1
2. Model classification according to the button size	2
3. Shape of buttons	2
II. NAME OF EACH COMPONENT	3
III. INSTALLATION OF THE SEWING MACHINE AND PREPARATION OF THE OPERATION ...	4
1. Installation of the table and stand	4
2. Needle and thread	4
3. Attaching the needle	4
4. Threading the machine	5
IV. OPERATION	6
1. Operation of the sewing machine	6
2. Various sewing modes	6
3. Operation of the button feeder unit	8
4. Operation	10
5. How to set the DIP switches and the digital switches	10
V. MAINTENANCE	16
1. Tilting the sewing machine head	16
2. Position of the button clamp jaw lever	17
3. Adjusting the feed plate	17
4. Adjusting the button clamp jaw lever	18
5. Adjusting the lifting amount of the button clamp	18
6. Adjustment of the pressure of the work clamp unit	19
7. Adjustment of the wiper	19
8. Adjustment of the wiper spring	19
9. Installing the save button bar (accessory part)	20
10. Adjustment of the button feeder unit control box	20
11. Detecting mechanism of the button feeder components and the adjustment	21
12. Adjusting the feed plate of the index unit	22
13. Replacing the button feeder components and positioning them	23
14. Adjusting the vibration of the button feeder	24
15. Adjusting the feeder bowl components	24
16. How to replace the buttons (on the button feeder side)	27
VI. ALARM NO. INDICATION (on the button feeder unit (BR) side)	29
VII. TROUBLES AND CORRECTIVE MEASURES IN BR	30
VIII. OPTIONAL PARTS	31
1. Kinds of the button carrier	31
2. Attachment	32
3. Others	33

I. SPECIFICATIONS

Different specifications from those of the LK-1900A only are described.

1. Specifications

- | | |
|---|--|
| 1. Sewing speed | : Max. 2,700 rpm (Normal speed : 2,500 rpm) |
| 2. Needle bar stroke | : 45.7 mm |
| 3. Needle | : DPX17 #14 |
| 4. Lifting lever method | : Joint use of stepping motor and cam (BR side) |
| 5. Lifting amount of button clamp | : Max. 11 mm |
| 6. Number of standard patterns | : 50 kinds |
| 7. Sewing speed limit | : Can be limited freely to 400 to 2,700 rpm.
(adjustable in a unit of 100 rpm) |
| 8. Buttons used | : Type : Round-shaped flat buttons (4-holed, 2-holed)
Size : $\varnothing 10$ mm to $\varnothing 18$ mm
(Note) 1. For buttons of which diameter is $\varnothing 16$ mm or more, the standard feed plate is required to be replaced with the feed plate 22B asm.
2. For buttons of which diameter is $\varnothing 16$ mm or more, use the button clamp jaw lever for large buttons.
Thickness : 1.8 to 3.5 mm |
| 9. Selection of buttons to be fed | : By vibration system using a piezoelectric feeder |
| 10. Button setting | : Buttons are loaded from the rear. (Manual loading possible) |
| 11. Button feeding method | : Horizontal forced feed mechanism |
| 12. Detection of a failure of feeding buttons | : Provided with two detectors <ul style="list-style-type: none">• One detector detects a button at the section where the button is correctly positioned.• Another detector checks whether the button is correctly inserted into the carrier pin. |
| 13. Driving source for the feeder | : DC motor (24 Vdc) |
| 14. Automatic button discharging function | : Provided |
| 15. Independent operation of the sewing machine | : Possible |
| 16. Small-lot sewing function | : Provided |
| 17. Time required to feed a button | : 0.5 sec/pc. |
| 18. Outer dimension | : W : 1,200 mm L : 660 mm H : 1,155 mm
(Standard table and stand used) |
| 19. Weight | : 135 kg (including optional table/stand) |
| 20. Power fluctuation | : Rated value ± 10 % 50/60 Hz |
| 21. Power consumption | : 350 W |
| 22. Noise | : Workplace-related noise at sewing speed
$n=2,300 \text{ min}^{-1}$: $L_{PA} \leq 80 \text{ dB (A)}$
Noise measurement according to DIN 45635-48-B-1. |

2. Model classification according to the button size

Model		LK-1903-311		LK-1903-312		
Button size classification		For small-sized buttons		For medium-sized buttons		
Outside diameter of applicable buttons (mm)		ø10 - ø15		ø12 - ø18		
Sewing size (mm)	Length	0 - 3.5		0 - 4.5		
	Width	0 - 3.5		0 - 4.5		
Button clamp jaw lever	Thickness (mm)	2.2		2.7		
	Part No.	Right	MAZ165070B0	H	MAZ166070B0	J
		Left	MAZ165080B0	H	MAZ166080B0	J
Needle hole guide		MAZ15501000		MAZ15601000		
Feed plate		MAZ15502000		MAZ15602000		

3. Shape of buttons

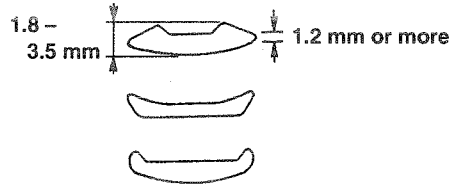
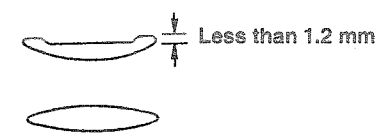
	Applicable buttons	Non-applicable buttons
Shape of buttons	 <p>1.8 - 3.5 mm</p> <p>1.2 mm or more</p>	 <p>Less than 1.2 mm</p> <p>Button without recess on the surface</p>
Remarks	Thickness of button : 1.8 to 3.5 mm	Button of which edge is thin is likely not to be fed smoothly.

II. NAME OF EACH COMPONENT

This machine is composed of the following components.

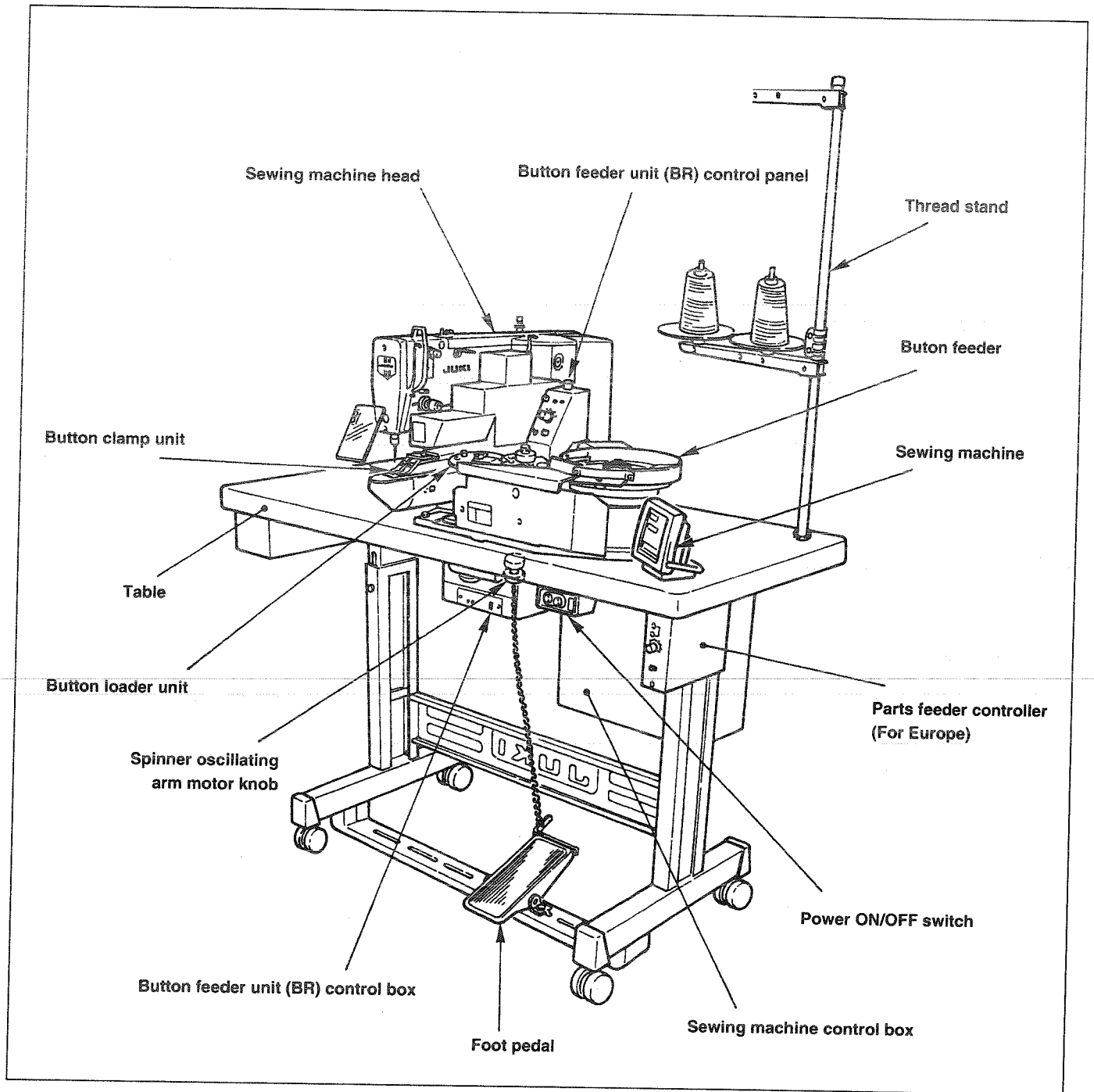

III. INSTALLATION OF THE SEWING MACHINE AND PREPARATION OF THE OPERATION

As for the descriptions other than those described in the following items, refer to the Instruction Manual for the LK-1900A.

1. Installation of the table and stand



WARNING :

Turn OFF the power before starting the work so as to prevent accidents caused by abrupt start of the sewing machine.

- (Caution)
1. Be sure to install the table and stand on a flat place.
 2. After the installation, be sure to fix the table and stand by locking the casters or adjusting the adjuster.
 3. When adjusting the height of the table, perform the work by two persons or more so as not to drop the table.

2. Needle and thread

Needle	Needle thread	Bobbin thread
DP x 17 #14	#60	#80
	#50	#60
	#40	#60
	#60	#60

Needle and thread will vary in accordance with the sewing conditions. When using the needle and the thread, select them referring to the left table. Cotton thread and spun thread are recommended.

3. Attaching the needle



WARNING :

Turn OFF the power before starting the work so as to prevent accidents caused by abrupt start of the sewing machine.

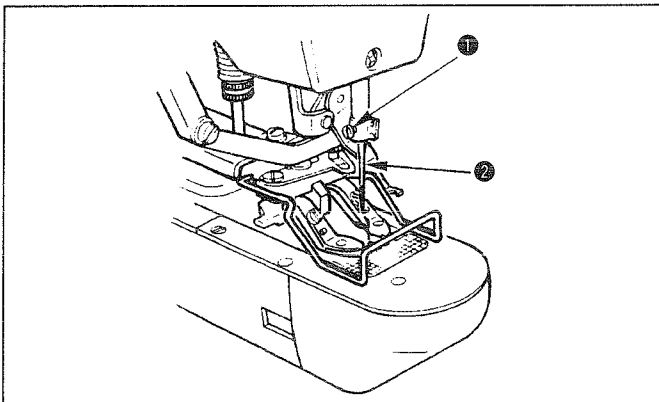

To attach the needle, loosen screw ①, insert needle ② fully into the needle bar hole with the long groove facing toward you, then tighten screw ①.

4. Threading the machine



WARNING :

Turn OFF the power before starting the work so as to prevent accidents caused by abrupt start of the sewing machine.

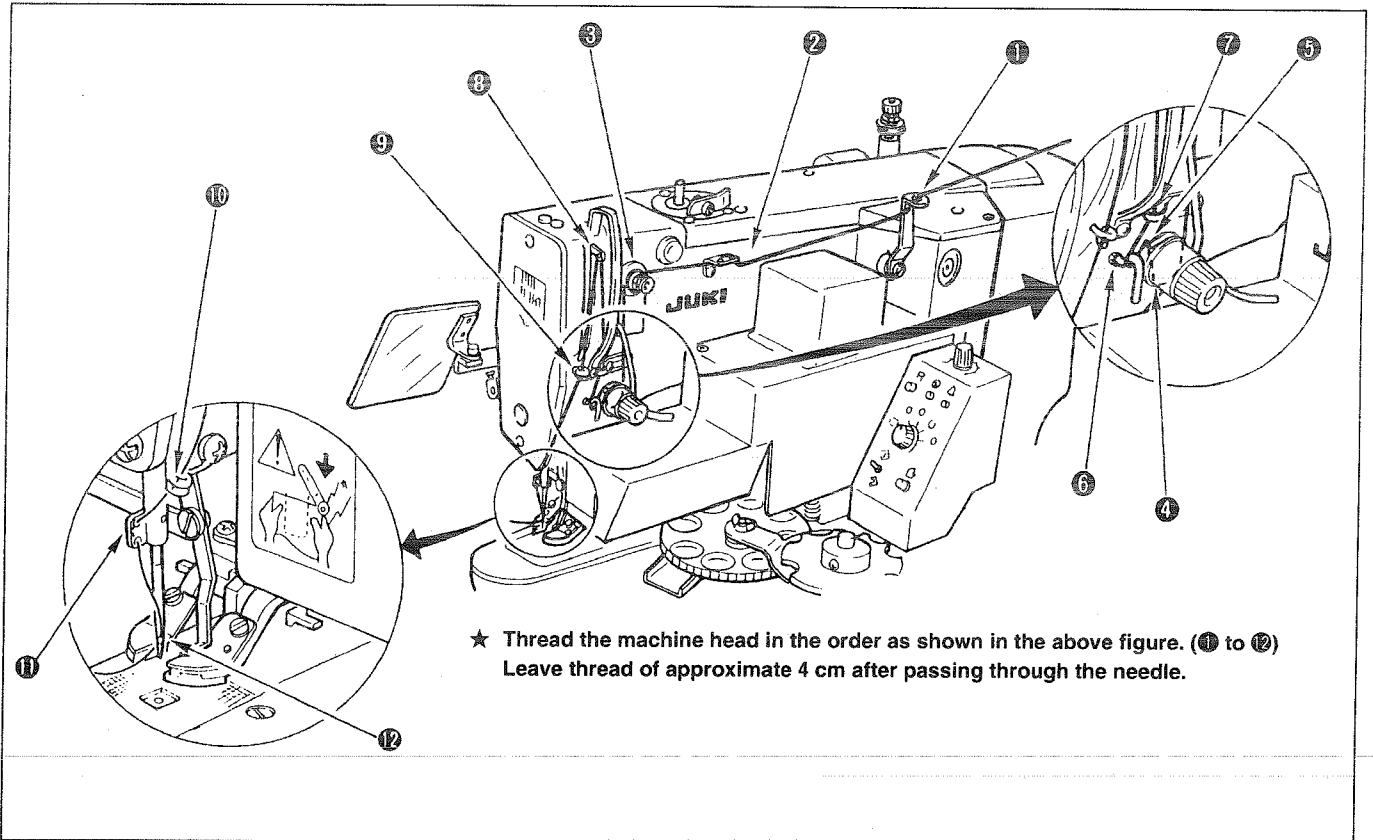

IV. OPERATION

1. Operation of the sewing machine

As for the operation of the sewing machine, refer to the Instruction Manual for the LK-1900A.



WARNING :

- When performing the selection of the pattern or enlargement/reduction of the sewing width, make sure of the needle entry point. If the needle extends outside the button hole or the sewing pattern extends outside the button clamp unit, the needle interferes with the button hole or the button clamp unit during sewing, resulting in the danger of the needle breakage or the like.
- While checking the shape of the pattern, do not depress the pedal upto the second step. Sewing will start by so depressing the pedal. So, be careful.

2. Various sewing modes

(1) Selection of the sewing pattern and the sewing width

- Selection of the sewing pattern is the same as that of the LK-1900A.
- When the distance between holes of the button used does not fit the standard sewing width of the sewing pattern No., adjust the sewing width by enlarging/reducing the sewing width.
The way of enlarging/reducing is the same as that of the LK-1900A. Refer to the table given below for the scale for enlargement/reduction in terms of the sewing width.
- As for the way of confirmation of the needle entry, refer to the confirmation of the shape of sewing pattern in the Instruction Manual for the LK-1900A.

(Caution) When ascertaining the needle entry point of the sewing pattern, there is a section of jump feed of one stitch before the needle mouse from the origin (center of the button) to the first stitch.

Table of XY scales in terms of the sewing width

X, Y (mm)	2.4	2.6	2.8	3.0	3.2	3.4	3.6	4.0	4.3	4.5	4.7	5.2	5.6	6.0	6.2	6.4
%	71	76	82	88	94	100	106	118	126	132	138	153	165	176	182	188

(2) Soft-start

Setting of the soft-start speed at the start of sewing of this machine is "1st stitch : 400 rpm, and 2nd stitch : 900 rpm" only at the time of standard delivery.

When slip-off of thread at the start of sewing or the like occurs, increase the number of stitches of the soft-start in accordance with the thread used and sewing products for use.

For the setting procedure of the soft-start, refer to "[8]-1. Setting example of the memory switch" of the Instruction Manual for LK-1900A.

































(3) Thread clamp

Thread clamp device of this machine is set to thread clamp motion prohibited (memory switch) at the time of standard delivery. When the thread clamp device is actuated, high-speed start or prevention of slip-off of needle thread at the start of sewing can be performed. However, there are some matters that demand special attention. When using the machine, refer to "[5]-6. Thread clamp device" of the Instruction Manual for LK-1900A.

(2) Sewing patterns

Number of threads and standard sewing size of X and Y are as shown in the following list.

<Sewing program list>

Pattern No.	Stitch shape	Number of threads (thread)	Standard sewing size X (mm)	Standard sewing size Y (mm)	Pattern No.	Stitch shape	Number of threads (thread)	Standard sewing size X (mm)	Standard sewing size Y (mm)		
1-34		6-6	3.4	3.4	18-44		6	3.4	0		
2-35		8-8			19-45		8				
3		10-10			20		10				
4		12-12			21		12				
5-36		6-6			22		16				
6-37		8-8			23-46		6	0	3.4		
7		10-10			24		10				
8		12-12			25		12				
9-38		6-6			3.4	3.4	26-47		6-6	3.4	3.4
10-39		8-8					27		10-10		
11		10-10	28-48				6-6				
12-40		6-6	29				10-10	2.9	2.5		
13-41		8-8	30-49				5-5-5				
14		10-10	31				8-8-8				
15-42		6-6	32-50				5-5-5				
16-43		8-8	33				8-8-8				
17		10-10									





* The standard sewing sizes of X and Y are when the enlargement/reduction rate is 100%.



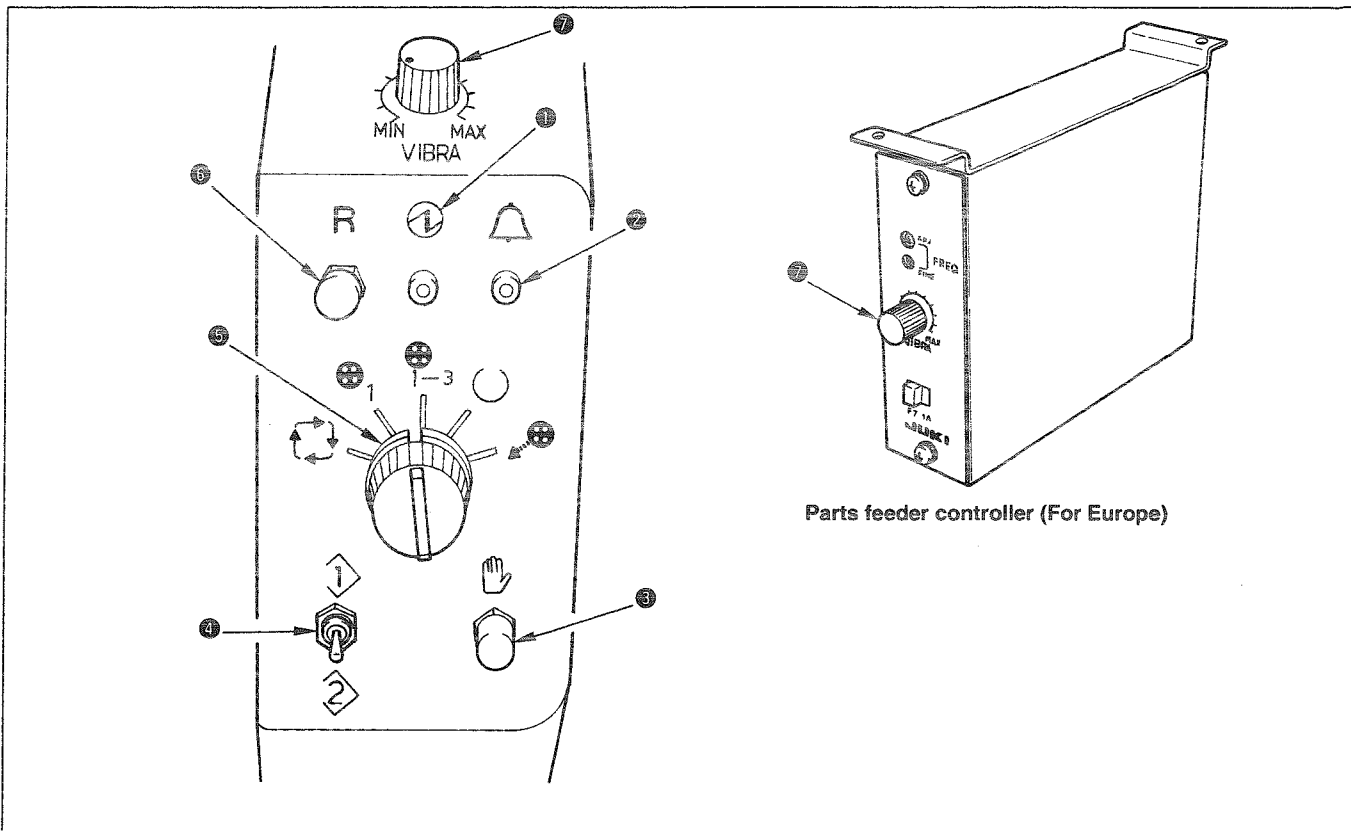



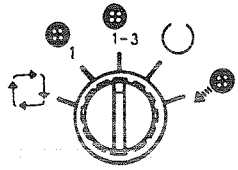

Use pattern No. 34 to No. 50 when the button hole is small (ø 1.5 mm or less).

3. Operation of the button feeder unit

(1) Explanation of the button feeder unit control panel

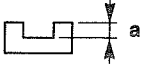

Symbol and name of switch	Function
<p>① Power indicator lamp (green)</p> 	<p>Lights up when the power switch is turned ON. If it fails to light up, check the power plug for secure connection and re-turn ON the power switch.</p>
<p>② Alarm indicator lamp (red)</p> 	<p>It slowly flashes on and off : When a failure of operation occurs. (Refer to "Alarm No. indication") (Note) It flashes on and off even in a state that the sewing LED on the sewing machine operation box goes out. It quickly flashes on and off : When the button sensor on the index unit continuously detects button feeding failure over 10 times.</p>
<p>③ MANUAL operation switch</p> 	<p>Used to manually actuate the series of operations under respective operation modes ("2. Independent sewing mode" is excluded.) which can be selected using mode selector switch ⑤.</p>
<p>④ Inspection switch</p> 	<p>Normally, this switch does not function. It is used to inspect the drive source and the sensors.</p>

Symbol and name of switch	Function
<p data-bbox="181 115 437 136">⑤ Mode selector switch</p> 	<p data-bbox="611 115 933 136">1. Automatic sewing mode </p> <p data-bbox="636 147 1528 304">The sewing machine and the button feeder operate with interlocked. Under this operation mode, depressing the foot pedal lowers the button clamp and makes the sewing machine start sewing a button. When the machine completes sewing of the button, the thread trimmer actuates, then the button feeder actuates to feed next button to be sewn. This series of operations is repeated under the automatic sewing mode.</p> <p data-bbox="611 325 949 357">2. Independent sewing mode </p> <p data-bbox="636 367 1528 514">This mode allows the sewing machine to independently operate. Under this mode, the operator sets the button to be sewn in the button clamp on the machine by hand. Then, depressing the foot pedal lowers the button clamp and makes the machine start sewing the button. When the machine completes sewing of the button, the thread trimmer actuates then the button clamp goes up.</p> <p data-bbox="611 535 916 567">3. Small-lot sewing mode </p> <p data-bbox="636 577 1528 703">Basically, series of operations performed under this mode is the same as that under the automatic sewing mode. The parts feeder, however, does not operate under this mode. The operator manually feeds buttons by the number desired to be sewn to the gear of index unit and let the machine perform button sewing.</p> <p data-bbox="611 724 1015 756">4. Prospective button feeding mode </p> <p data-bbox="636 766 1528 819">Under this mode, the fine positioning completion sensor function is stopped and the machine performs fine positioning of a button in a predetermined period of time (set by DEG-SW-2.).</p>  <p data-bbox="933 850 1387 882">a = Suited to buttons of which is 1 mm or more.</p> <p data-bbox="611 913 949 945">5. Button discharging mode </p> <p data-bbox="636 955 1528 1081">Under this mode, buttons in the index unit are automatically discharged by pressing manual operation switch . In this case, the button is discharged to the discharging chute located at the lower section of the button positioner. So, place a pan or the like to receive the discharged buttons at the exit area. At this time, do not place your fingers around the button clamp unit until the operation completes since the button carrier actuates.</p>
<p data-bbox="173 1113 338 1134">⑥ Reset switch</p> 	<p data-bbox="602 1113 1511 1207">Press this switch to reset the machine from its error stop state to its normal operative state. (Note that alarm Nos. 4 and 5 cannot be reset using the reset switch. Turn OFF the power once, eliminate the cause of the trouble and re-turn ON the power to the machine.)</p>
<p data-bbox="173 1260 578 1312">⑦ Parts feeder (P/F) adjusting variable resistor dell'alimentatore parti (P/F)</p> 	<p data-bbox="602 1260 1098 1281">Used to adjust the flow of buttons in the feeder bowl.</p> <p data-bbox="602 1291 1511 1344">(Note) For the European specifications only, adjustment is performed with a separate control box.</p>

4. Operation

(Caution) Move the button clamp jaw levers near to the position of the needle center in advance.

- 1) Turn ON the power to the main unit of the sewing machine.
At this time, the alarm indication on the button feeder unit control panel flashes on and off, and the alarm indication on the button feeder unit control box indicates "0" (flashing).
- 2) Press the [Ready] key on the sewing machine operation box, and the sewing LED lights up to release the alarm indication on the unit. Then the button clamp jaw levers move to the origin and go up. (A state that the sewing is possible.)
- 3) Press the manual operation switch on the button feeder unit control panel, and supply the button clamp jaw levers with a button. If the button is not supplied to the button clamp jaw levers, press the manual operation switch again.
- 4) When depressing the pedal to the first step, the button clamp jaw levers come down. At this time, make sur of the sewing position. (If you release your foot from the pedal, the button clamp jaw levers go up.)
- 5) Furthermore depressing the pedal makes the sewing machine perform sewing the button in accordance with the pattern No.
- 6) When the sewing is completed, the button clamp jaw levers go up, the button carrier of button supply unit turns, and a button is supplied.

5. How to set the DIP switches and the digital switches



WARNING :

Turn OFF the power before starting the work so as to prevent accidents caused by abrupt start of the sewing machine.

Loosen two screws ❶, and open panel ❷ as illustrated in the following figure to change the setting of the respective switches.

Button feeder unit control box

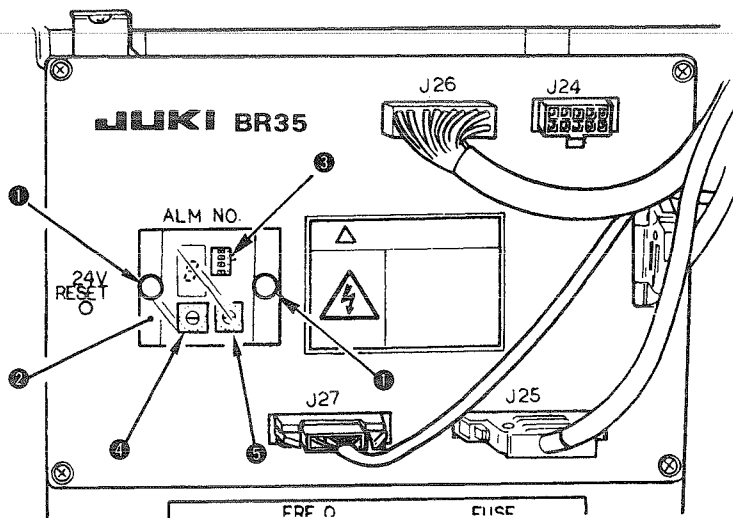

- ❸ DIP switch (DIP-SW)
- ❹ Digital switch (DEG-SW-1)
- ❺ Digital switch (DEG-SW-2)

(1) DIP switch function

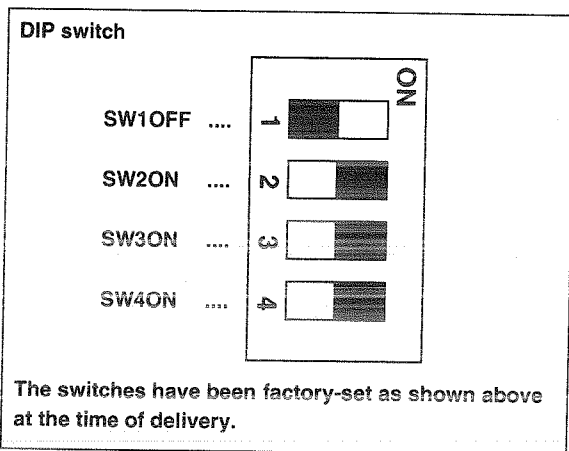

Function	DIP switch			
	SW1	SW2	SW3	SW4
Continuous cycle mode	○	×	△	△
Double-stepped action of the button clamp	×	○	△	△
Adjustment mode	×	×	○	×
Action without button	×	×	×	○

○ ON × OFF

△ The machine performs the operations described in next page and beyond in accordance with combination of the DIP switches.

SW1 Continuous cycle mode

Buttons are continuously sewn by keeping the pedal depressed. Refer to the next page and beyond for the detailed description of the sewing machine operating intervals and the length of time during which the machine performs fine positioning of a button.

SW2 Double-stepped action of the button clamp

Depress the pedal to its middle position to make the button clamp come down. This function is used in this state to automatically raise the button clamp by returning the pedal to its home position. The sewing machine starts running when the pedal is fully depressed.

Refer to the next page and beyond for the detailed description of the timing at which the button carrier moves after the operation of the sewing machine and the time during which the machine performs fine positioning of a button.

SW3 Adjustment mode



This function is used to make each of the driving sources independently actuate in combination with the operation switches. Under this mode, the indicator of "ALM No." indicates ON/OFF of sensors using the numbers and the like corresponding to the respective sensors.

SW4 Action without button

The button detecting sensors are ineffective, and the functions of the sewing machine excluding the button feeder are operative. This function is used to check the performance of the sewing machine. (Do not place a button on the sewing machine.)



(Caution) To change the functions of the sewing machine by changing over the setting of DIP switch ③ and digital switches ④ and ⑤, turn OFF the power to the machine first, change the switch setting and turn ON the power to the machine. Change over the setting position of DIP switches between ON and OFF without fail.

(2) List of functions and setting of the DIP switch and the digital switch (part 1)

No.	Function	Application	Automatic sewing mode (Note 3) 	Prospective button feeding mode (Note 8) 	Set position of  DIP-SW			
					1	2	3	4
1	Continuous cycle mode (Note 1)	Applicable to many different kinds of button. (Buttons are rarely locked in the button feeder.)	<ul style="list-style-type: none"> Normal operation function Provided with a sensor which detects completion of fine positioning of a button. Automatic button discharging function Stitching timing adjusting function (Note 6) Function of adjusting the length of time during which the fine positioning of a button is performed. 	<ul style="list-style-type: none"> Normal operation function Prospective button feeding function (Not provided with a sensor which detects completion of fine positioning of a button.) Stitching timing adjusting function Function of adjusting the length of time during which the fine positioning of a button is performed. 	○	×	○	○
2		Suited to a single type of button (flat buttons). Buttons are likely to be locked in the button feeder as compared with the aforementioned No. 1.	<ul style="list-style-type: none"> High-speed operation function (Note 9) Provided with a sensor which detects completion of fine positioning of a button. Automatic button discharging function Stitching timing adjusting function Function of adjusting the length of time during which the fine positioning of a button is performed. 	Ditto	○	×	×	×
3		Ditto	Ditto	<ul style="list-style-type: none"> High-speed operation function Prospective button feeding function (Not provided with a sensor which detects completion of fine positioning of a button.) Stitching timing adjusting function Function of adjusting the length of time during which the fine positioning of a button is performed. 	○	×	○	×
4		Two different kinds of continuous sewing and point stitching such as sewing hip pocket can be performed alternately.	<ul style="list-style-type: none"> Normal operation function Provided with a sensor which detects completion of fine positioning of a button. Automatic button discharging function Function of adjusting the length of time during which the button carrier operates. (Note 11) Function of adjusting the length of time during which the fine positioning of a button is performed. 	<ul style="list-style-type: none"> Normal operation function Prospective button feeding function (Not provided with a sensor which detects completion of fine positioning of a button.) Function of adjusting the length of time during which the button carrier operates. Function of adjusting the length of time during which the fine positioning of a button is performed. 	○	×	×	○
5	Double-stepped action of the button clamp (Note 2)	Standard specifications at the time of delivery Applicable to many different kinds of button (Buttons are rarely locked in the button feeder.)	<ul style="list-style-type: none"> Normal operation function (Note 4) Provided with a sensor which detects completion of fine positioning of a button. Automatic button discharging function. (Note 5) Not provided with the stitching timing adjusting function. (Note 10) Function of adjusting the length of time during which the fine positioning of a button is performed. (Note 7) 	<ul style="list-style-type: none"> Normal operation function Prospective button feeding function (Not provided with a sensor which detects completion of fine positioning of a button.) Not provided with the stitching timing adjusting function. Function of adjusting the length of time during which the fine positioning of a button is performed. 	×	○	○	○
6		Suited to a single type of button (flat buttons). Buttons are likely to be locked in the button feeder as compared with the aforementioned No. 5.	<ul style="list-style-type: none"> High-speed operation function Provided with a sensor which detects completion of fine positioning of a button. Automatic button discharging function Not provided with the stitching timing adjusting function. Function of adjusting the length of time during which the fine positioning of a button is performed. 	Ditto	×	○	×	×
7		Ditto	Ditto	<ul style="list-style-type: none"> High-speed operation function Prospective button feeding function (Not provided with a sensor which detects completion of fine positioning of a button.) Not provided with the stitching timing adjusting function. Function of adjusting the length of time during which the fine positioning of a button is performed. 	×	○	○	×

DEG, SW-1	DEG, SW-2	Cautions																																						
<p>Stitching timing (Note 6)</p> <ul style="list-style-type: none"> The length of time during which the button carrier operates and the button clamp jaw levers are in their highest position waiting for a button. <table border="0"> <tr> <td>0 → 0.05 SEC</td> <td>8 → 0.05</td> </tr> <tr> <td>1 → 0.10</td> <td>9 → 0.10</td> </tr> <tr> <td>2 → 0.15 : Standard</td> <td>A → 0.15</td> </tr> <tr> <td>3 → 0.20</td> <td>B → 0.20</td> </tr> <tr> <td>4 → 0.25</td> <td>C → 0.25</td> </tr> <tr> <td>5 → 0.30</td> <td>D → 0.30</td> </tr> <tr> <td>6 → 0.35</td> <td>E → 0.35</td> </tr> <tr> <td>7 → 0.40</td> <td>F → 0.40</td> </tr> </table> <p>(The length of time during which the index operates is fixed at the following values.)</p> <table border="0"> <tr> <td>0 to 7 → 0.08 SEC</td> </tr> <tr> <td>8 to F → 0.16</td> </tr> </table> <p>The longer the aforementioned length of time is specified, the better the overall timing of the sewing machine will become.</p>	0 → 0.05 SEC	8 → 0.05	1 → 0.10	9 → 0.10	2 → 0.15 : Standard	A → 0.15	3 → 0.20	B → 0.20	4 → 0.25	C → 0.25	5 → 0.30	D → 0.30	6 → 0.35	E → 0.35	7 → 0.40	F → 0.40	0 to 7 → 0.08 SEC	8 to F → 0.16	<p>The longest time during which the fine positioning of a button is performed. (Note 7)</p> <table border="0"> <tr> <td>0 → 0.20 SEC</td> <td>8 → 0.20</td> </tr> <tr> <td>1 → 0.30 : Standard</td> <td>9 → 0.30</td> </tr> <tr> <td>2 → 0.50</td> <td>A → 0.50</td> </tr> <tr> <td>3 → 0.80</td> <td>B → 0.80</td> </tr> <tr> <td>4 → 0.20</td> <td>C → 0.20</td> </tr> <tr> <td>5 → 0.30</td> <td>D → 0.30</td> </tr> <tr> <td>6 → 0.50</td> <td>E → 0.50</td> </tr> <tr> <td>7 → 0.80</td> <td>F → 0.80</td> </tr> </table> <p>(Length of time during which the triple pawl is held closed.)</p> <table border="0"> <tr> <td>0 to 3 → 0.10 SEC</td> </tr> <tr> <td>4 to 7 → 0.15</td> </tr> <tr> <td>8 to B → 0.20</td> </tr> <tr> <td>C to F → 0.25</td> </tr> </table>	0 → 0.20 SEC	8 → 0.20	1 → 0.30 : Standard	9 → 0.30	2 → 0.50	A → 0.50	3 → 0.80	B → 0.80	4 → 0.20	C → 0.20	5 → 0.30	D → 0.30	6 → 0.50	E → 0.50	7 → 0.80	F → 0.80	0 to 3 → 0.10 SEC	4 to 7 → 0.15	8 to B → 0.20	C to F → 0.25	<p>(Note 1) The continuous cycle mode is a state where the sewing machine is operated with the pedal held depressed. The button clamp jaw levers go up, and come down after waiting for the period of set time. Then the sewing machine starts.</p> <p>(Note 2) When the double stepped action function of the button clamp is selected, depress the pedal every time to operate the button clamp.</p> <p>(Note 3) Automatic stitching mode</p> <ul style="list-style-type: none"> When the automatic stitching mode is specified, the fine positioning completion detecting sensor will function. This means that the sewing machine will not start unless a button is supplied to the button clamp jaw levers. <p>(Note 4) Normal operation function</p> <ul style="list-style-type: none"> Function to place no button on the shutter plate excluding fine positioning of a button. A load is not likely to be applied to the shutter plate and the carrier. As a result, the related components do not easily break. <p>(Note 5) Automatic button discharging function</p> <ul style="list-style-type: none"> if the fine positioning completion sensor fails to detect the completion of the fine positioning of button to feed a button, and the predetermined time to perform fine positioning is exceeded, the machine will automatically release the shutter plate to make the button carrier actuate. If the button discharging function is performed three times continuously, ERROR 3 will result. To reset the ERROR, press the MANUAL operation switch. If the automatic discharging occurs frequently, suppose that some mechanical trouble has occurred and check the mechanical components for failure. <p>(Note 6) Stitching timing adjusting function (DEG, SW-1)</p>
0 → 0.05 SEC	8 → 0.05																																							
1 → 0.10	9 → 0.10																																							
2 → 0.15 : Standard	A → 0.15																																							
3 → 0.20	B → 0.20																																							
4 → 0.25	C → 0.25																																							
5 → 0.30	D → 0.30																																							
6 → 0.35	E → 0.35																																							
7 → 0.40	F → 0.40																																							
0 to 7 → 0.08 SEC																																								
8 to F → 0.16																																								
0 → 0.20 SEC	8 → 0.20																																							
1 → 0.30 : Standard	9 → 0.30																																							
2 → 0.50	A → 0.50																																							
3 → 0.80	B → 0.80																																							
4 → 0.20	C → 0.20																																							
5 → 0.30	D → 0.30																																							
6 → 0.50	E → 0.50																																							
7 → 0.80	F → 0.80																																							
0 to 3 → 0.10 SEC																																								
4 to 7 → 0.15																																								
8 to B → 0.20																																								
C to F → 0.25																																								
<p>Releasing the pedal while the sewing machine is in operation will retard the time at which the button carrier actuates by one second.</p>		<p>(Note 6) Stitching timing adjusting function (DEG, SW-1)</p>																																						
<p>Since the function of adjusting the stitching timing is not provided, DEG-1 has the function of setting the length of time at which the triple pawl actuates after the index has operated. (Note 10)</p> <p>(Index time : DEG-1)</p> <table border="0"> <tr> <td>0 to 7 → 0.08 SEC</td> </tr> </table> <p>(Standard specification is "2" at the time of delivery.)</p> <table border="0"> <tr> <td>8 to F → 0.16</td> </tr> </table>	0 to 7 → 0.08 SEC	8 to F → 0.16		<ul style="list-style-type: none"> This function is effective only when the continuous stitching function is specified (Nos. 1 to 4). When one to four buttons are continuously sewn, the sewing speed will gradually decrease by stages and the length of time required to sew the buttons will change. As a result, the operator's constant sewing rhythm will be disturbed. To achieve a constant sewing speed, this function is used to adjust the length of time required to sew the first to third buttons to that is required to sew the fourth button. <p>(Note 7) Function to adjust the length of time required to finely position a button (DEG, SW-2)</p> <ul style="list-style-type: none"> This function is used to set the time to actuate the automatic button discharging function. This function is also used to set the length of time during which the fine positioner operates when the prospective button feeding function is specified. <p>(Note 8) Prospective button feeding function</p> <ul style="list-style-type: none"> Use this function when sewing a button which has a recess on the surface (the difference in height between the bottom of recess and edge is 1 mm or more.). When this function is used, the fine positioning completion detecting sensor becomes inoperative. So, the machine performs fine positioning of a button for the length of time set using the DEG, SW-2, and the machine, every time, opens the shutter plate and actuates the button carrier constantly at the predetermined time. This means that the length of time required for sewing is likely to change when compared with the sewing under the automatic sewing mode. When this function is used, the fine positioning completion detecting sensor becomes inoperative. Consequently, the sewing machine starts even when a button is not fed to the button clamp jaw levers. When this function is used, ERROR 3, which occurs when the automatic button discharging function is used, will not occur. 																																				
0 to 7 → 0.08 SEC																																								
8 to F → 0.16																																								

List of functions and setting of the DIP switch and the digital switch (part 2)

No.	Function	Application	Automatic stitching mode (Note 3) 	Prospective button feeding mode (Note 8) 	Set position of DIP, SW			
					1	2	3	4
8	Double-stepped action of the button clamp	Suited to be used exclusive for point stitching such as sewing hip pockets	<ul style="list-style-type: none"> • Normal operation function • Provided with a sensor which detects completion of fine positioning of a button. • Automatic button discharging function • Function of adjusting the length of time during which the button carrier operates. (Note 11) • Function of adjusting the length of time during which the fine positioning of a button is performed. 	<ul style="list-style-type: none"> • Normal operation function • Prospective button feeding function (Not provided with a sensor which detects completion of fine positioning of a button.) • Function of adjusting the length of time during which the button carrier operates. • Function of adjusting the length of time during which the fine positioning of a button is performed. 	×	○	×	○

DEG, SW-1	DEG, SW-2	Cautions
<ul style="list-style-type: none"> • Length of time during which the button carrier operates. 0 → 0.20 SEC 8 → 0.20 1 → 0.50 9 → 0.50 2 → 0.80 A → 0.80 3 → 1.20 B → 1.20 4 → 1.60 C → 1.60 5 → 2.00 D → 2.00 6 → 3.00 E → 3.00 7 → SW stand-by F → SW stand-by (Length of time during which the index operates.) (Note 12) 0 to 7 → 0.08 SEC 8 to F → 0.16 		<p>(Note 9) High-speed operating function</p> <ul style="list-style-type: none"> • This function means that a button always rests on the shutter plate. • Since the button carrier operates with the shutter plate closed, a load is likely to be applied to the shutter plate and the button carrier when the machine is locked. <p>(Note 10) Not provided with the stitching timing adjusting function. In the double-stepped action of the button clamp (Nos. 5 to 7), the stitching timing adjusting function is not necessary. So, the DEG, SW-1 is used only to set the length of time required to make the triple pawl actuate after the index operated.</p> <p>(Note 11) Function to adjust the button carrier operating timing</p> <ul style="list-style-type: none"> • If the sewing product may be caught in the button carrier when attaching buttons to hip pockets or the like, this function can be used to delay the actuation of the button carrier in accordance with the length of time specified by the DEG, SW-1. <p>(Note 12) SW (Switch) stand-by</p> <ul style="list-style-type: none"> • The button carrier operates when the manual operation switch on the operation panel is pressed. • If the knee switch is used, connect it to the pins 9 and 10 of J24 on the control box. Then the "switch stand-by" function can be used. (This feature is available by a special order.) <p>(Caution)</p> <ul style="list-style-type: none"> • For all the functions controlled by the DIP switches (DIP-SW), it is possible to stop the subsequent action of the button carrier by pressing the manual operating switch or the knee switch (special order part) while the sewing machine is in operation, and to actuate the button carrier by pressing it again. • If a button comes off the index unit, the machine makes the button carrier actuate, with no button, once after the completion of sewing to allow the operator to remove the material from the machine with ease. • If, when the automatic button discharging function works, the predetermined length of time for fine positioning of a button has passed before a button is placed on the button carrier, the shutter plate will be opened and the button will be discharged. At this time, it is possible that the discharged button is accidentally placed on the button carrier. In this case, the button carrier will be actuated twice. As a result, two buttons will be fed to the button carrier, causing needle breakage. To prevent this, the time for starting the sewing machine is retarded by 0.5 sec. if the automatic button discharging function has actuated. (It is possible to decrease the frequency of actuation of the automatic button discharging function by increasing the length of time during which the machine performs fine positioning of a button.) • When the double-stepped action of the button clamp is selected and the operator operates the pedal too quickly, the button clamp jaw levers will go up before it opens after the completion of sewing. In this case, the operator cannot smoothly move the material on the machine. To prevent this, the time for turning ON the button clamp jaw lever lifting magnet should delay by 0.2 sec. to give priority to mechanical actions.

V. MAINTENANCE

1. Tilting the sewing machine head



WARNING :

Tilt / raise the sewing machine head with both hands taking care not to allow your fingers to be caught in the head.

Turn OFF the power before starting the work so as to prevent accidents caused by abrupt start of the sewing machine.

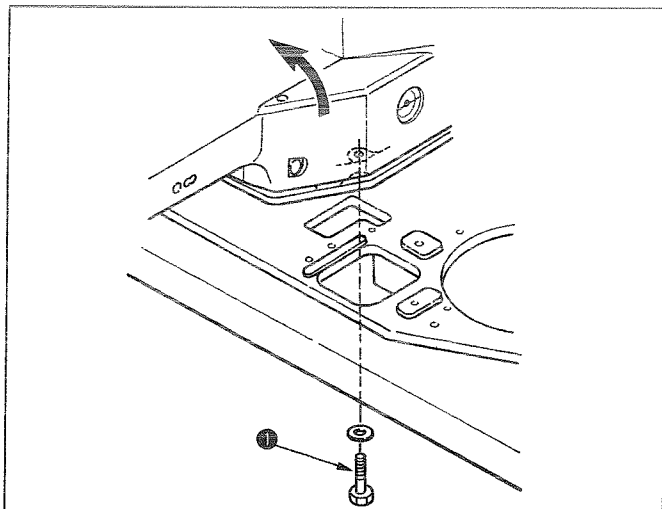

Remove screw ①, and slowly tilt the sewing machine head in the direction of arrow.

(Caution)

1. The sewing machine has been fixed with screw ① at the time of delivery. Normally, use the sewing machine in a fixed state.

2. When tilting the sewing machine, be sure to perform the work at the position of the origin of the button carrier.

The sewing machine head may interfere with the button carrier.

3. Return the sewing machine head gently when returning it to its home place.

If it is returned quickly, the base portion may be damaged. In addition, be careful not to allow your fingers to be caught in between portion ① and the sewing machine head.

4. When returning the sewing machine head, move the position of button clamp unit ② in the direction of ③ so that portion ④ of button clamp unit ② is located on the rear side of the clamp release arm ⑤ of the button feeder. Otherwise, button clamp jaw levers ⑥ do not open at the time of sewing. So, be careful.

5. After returning the sewing machine head, be sure to fix the sewing machine head with screw ①.

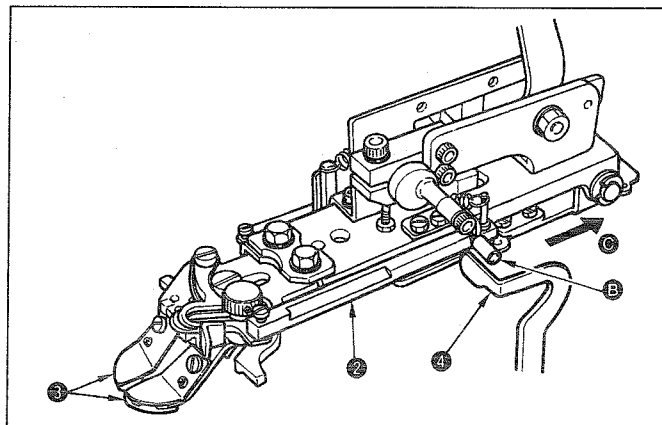
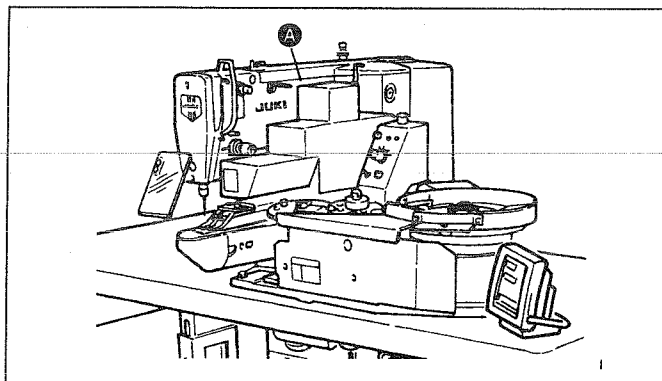

2. Position of the button clamp jaw lever



WARNING :

When the adjustment of the position is performed, make sure of the needle entry point. If the needle extends outside the button hole or the sewing pattern extends outside the button clamp unit, the needle interferes with the button hole or the button clamp unit during sewing, resulting in the danger of needle breakage or the like.

Do not depress the pedal upto the second step during the adjustment. The button carrier will actuate by so depressing the pedal. So, be careful.

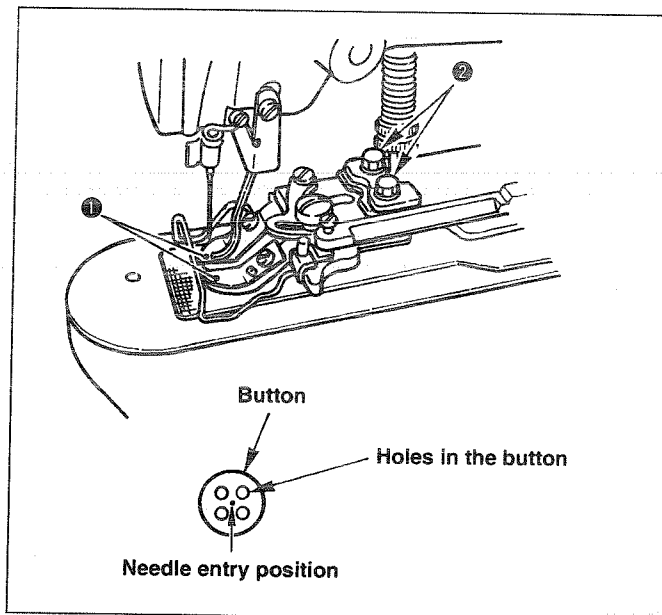

- 1) Press **[M]** key in the state that the swing LED goes off using the operation panel.
- 2) Press **[P1]** key. → **[0]**
- 3) Press **[U]** key. The button clamp unit goes to the origin position and goes up.
- 4) Place a button in button clamp jaw levers **①**.
- 5) Depress the pedal to the first step and detach your foot from the pedal when the button clamp unit comes down.
- 6) Turn the hand pulley and check that the center of the needle enters the center of the button.
- 7) If the center of the needle is not located in the center of the button, loosen screws **②** in the button clamp jaw lever base to adjust so that the center of the needle enters the center of the button.
- 8) When depressing the pedal to the second step at step 5), the button clamp unit moves again to the origin position. In addition, when the button clamp unit comes down, depress the pedal to the first step and detach the foot from the pedal. Then the button clamp unit goes up.
- 9) As for the way of confirmation, refer to "2. Checking the contour of a sewing pattern in the Instruction Manual for the LK-1900A".

3. Adjusting the feed plate



WARNING :

When the adjustment of the position is performed, make sure of the shape of the sewing pattern. If the feed plate interferes with the needle hole guide, it will result in the danger of the needle breakage or the like. Also, if the pedal is depressed during the adjustment, the button clamp unit will go up or come down. So, be careful.

Do not depress the pedal to the second step, during the adjustment, in a state that the sewing LED lights up. The button carrier will actuate by so depressing the pedal. So, be careful.

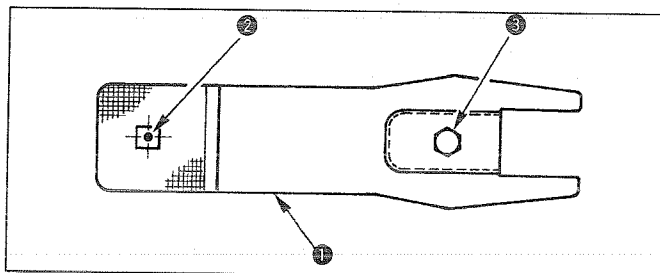

- 1) Press **[M]** key in the state that the swing LED goes off using the operation panel.
- 2) Press **[P1]** key. → **[0]**
- 3) Press **[U]** key. The button clamp unit goes to the origin position and goes up.
- 4) Adjust feed plate **①** by loosening screw **③** so that needle hole guide **②** comes to the center of the recessed part of feed plate **①**. 1) Press **[M]** key in the state that the swing LED goes off using the operation panel.

4. Adjusting the button clamp jaw lever



WARNING :

Turn OFF the power before starting the work so as to prevent accidents caused by abrupt start of the sewing machine.

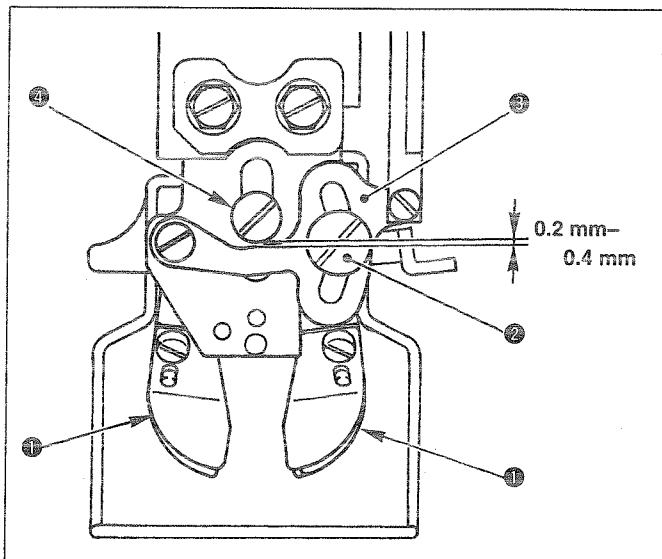

Bring the machine to its stop-motion state. Then lift button clamps ①. Loosen screw ② in the button clamp jaw lever and adjust so that a clearance of 0.2 to 0.4 mm is provided between button clamp jaw lever ③ and hinge screw ④ when placing a button in between button clamps ①.

5. Adjusting the lifting amount of the button clamp



WARNING :

Do not depress the pedal to the second step, during the adjustment, in a state that the sewing LED lights up. The button carrier will actuate by so depressing the pedal. So, be careful.

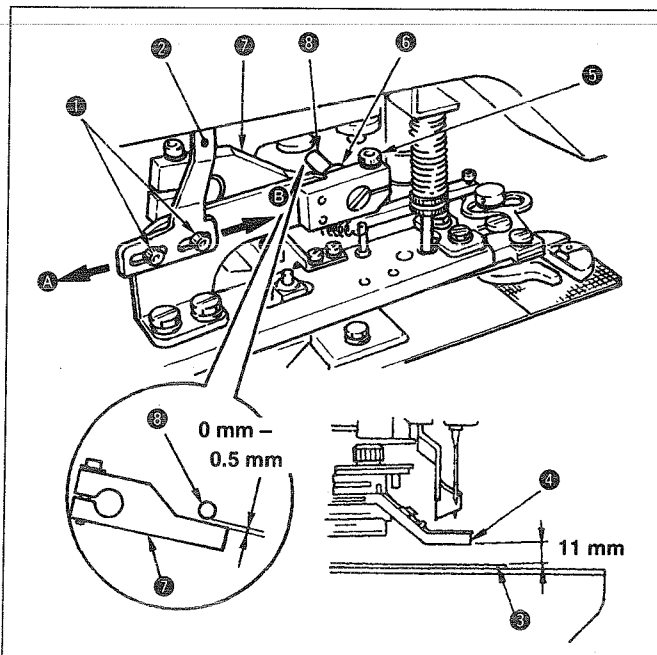

- 1) Press **[M]** key in the state that the swing LED goes off using the operation panel.
- 2) Press **[P1]** key. → **[[0]]**
- 3) Press **[U]** key. The button clamp unit goes to the origin position and goes up.
- 4) Loosen two screws ①, and move work clamp foot lifting plate ② back and forth in the direction of arrow to adjust so that the top end of button clamp ④ is 11 mm above throat plate ⑤.
Move work clamp foot lifting plate ② in direction **A** to decrease the lifting amount, and move it in direction **B** to increase the lifting amount.
After the adjustment, securely tighten screws ①.
- 5) Turn knob ⑨ of the spinner oscillating arm motor on the unit side, and when work clamp lifting arm ⑦ has stopped its lifting once, loosen screw ⑤ and turn work clamp hook ⑥ to adjust so that a clearance of 0 to 0.5 mm is provided between roller ⑧ and work clamp lifting arm ⑦.
- 6) After the adjustment, check that the buttons are securely supplied.

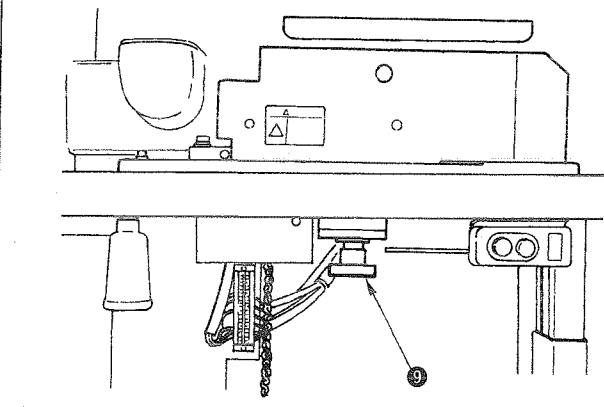

6. Adjustment of the pressure of the work clamp unit



WARNING :

Turn OFF the power before starting the work so as to prevent accidents caused by abrupt start of the sewing machine.

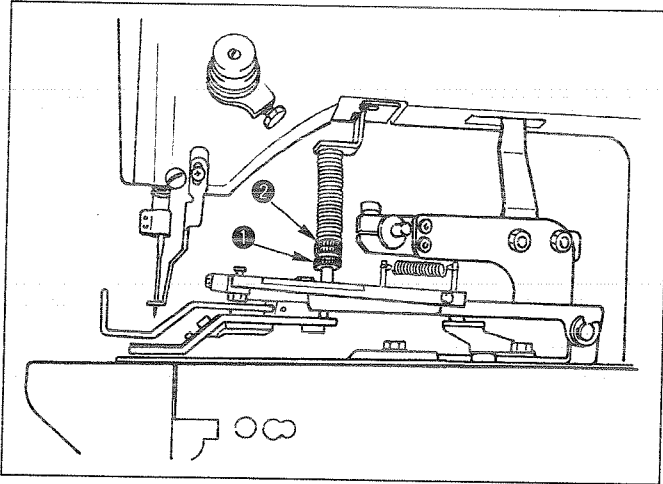

The pressure of the work clamp unit should be minimized as long as the material does not warp during sewing. Loosen adjusting screw ① and turn adjusting screw ② to obtain the aforementioned pressure.

7. Adjustment of the wiper



WARNING :

Turn OFF the power before starting the work so as to prevent accidents caused by abrupt start of the sewing machine.

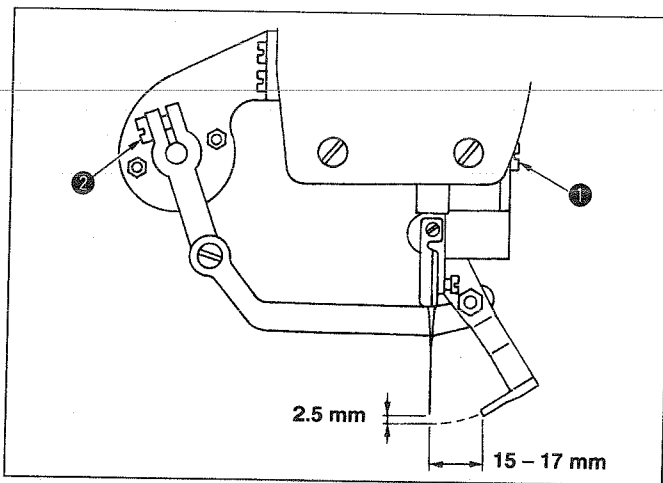

- 1) Loosen screw ① to adjust so that a clearance of 2.5 mm or more is provided between the wiper and the needle.
- 2) Loosen screw ② to adjust so that a distance of 15 to 17 mm is provided between the end face of the wiper and the center of the needle. After the adjustment, securely tighten the screw.

(Caution)

The position of the needle is when the sewing machine has stopped after the sewing finished.

8. Adjustment of the wiper spring



WARNING :

Turn OFF the power before starting the work so as to prevent accidents caused by abrupt start of the sewing machine.

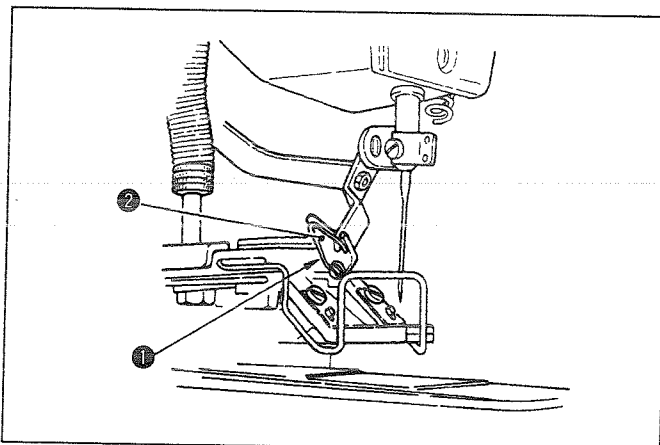

Wiper spring ① retains the needle thread after thread trimming in between wiper ② and the wiper spring. Correct properly the tension of wiper spring ① so that the tension at that time becomes 0.2 to 0.3N (a little higher tension than that of the bobbin thread coming out of the bobbin case).

(Caution)

If the retaining of the needle thread is excessive, the thread may protrude from the upper side of the button.

9. Installing the save button bar (accessory part)



WARNING :

Turn OFF the power before starting the work so as to prevent accidents caused by abrupt start of the sewing machine.

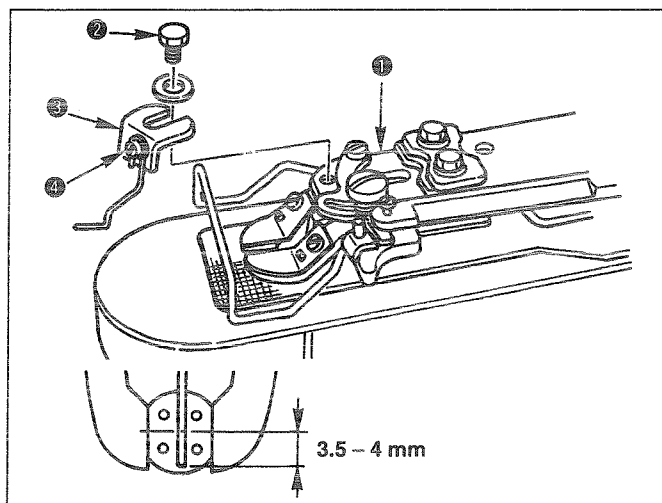

- 1) Install save button bar mounting plate ① on button clamp base ② with hexagon screw ③.
- 2) Adjust so that a clearance of 3.5 to 4 mm is provided between the center of the button and the top end of the save button bar.
- 3) To adjust the raising amount of the save button bar, loosen screw ④, and move the save button bar up or down.

10. Adjustment of the button feeder unit control box



WARNING :

Turn OFF the power before starting the work so as to prevent accidents caused by electric shock.

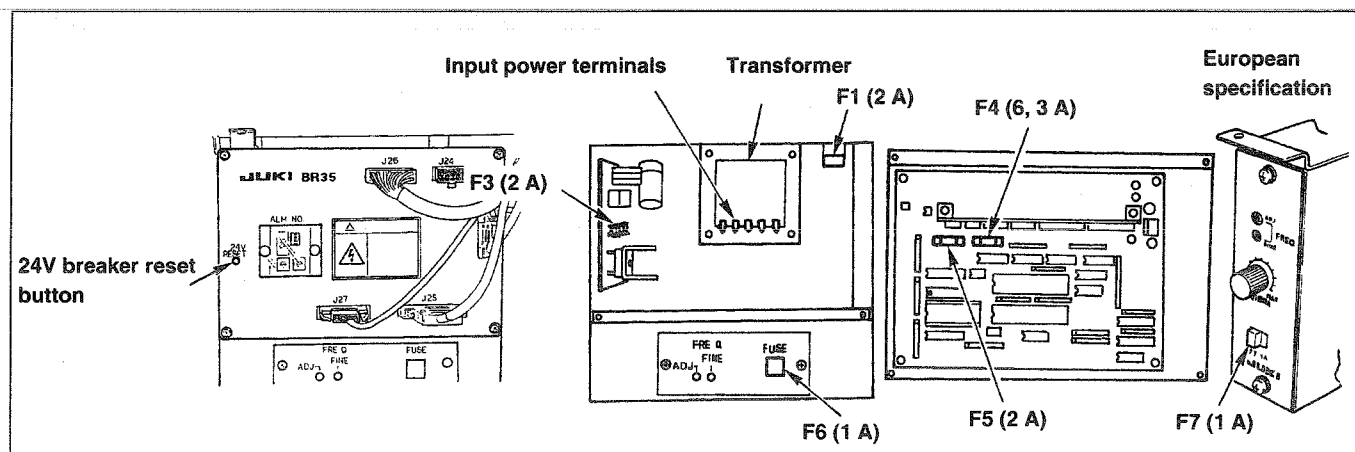

(1) 24V breaker trip

An overcurrent of the 24Vdc line will trip the breaker mounted on the front face of the control box. To reset, press the white part of the reset button using a thin pin or the like until the part clicks.

(2) Confirm the input power terminal of the transformer (Change the terminal in accordance with the service voltage of the market where the sewing machine is to be used.)

(3) Replacing the fuse

You may find six fuses (F1, F3 through F7) as illustrated in the figure. (Remove the frame cover on the front face of the control box, and replace the fuses.)

11. Detecting mechanism of the button feeder components and the adjustment



WARNING :

Perform the work in the state where the sewing LED goes out so as to prevent accidents caused by abrupt start of the sewing machine.

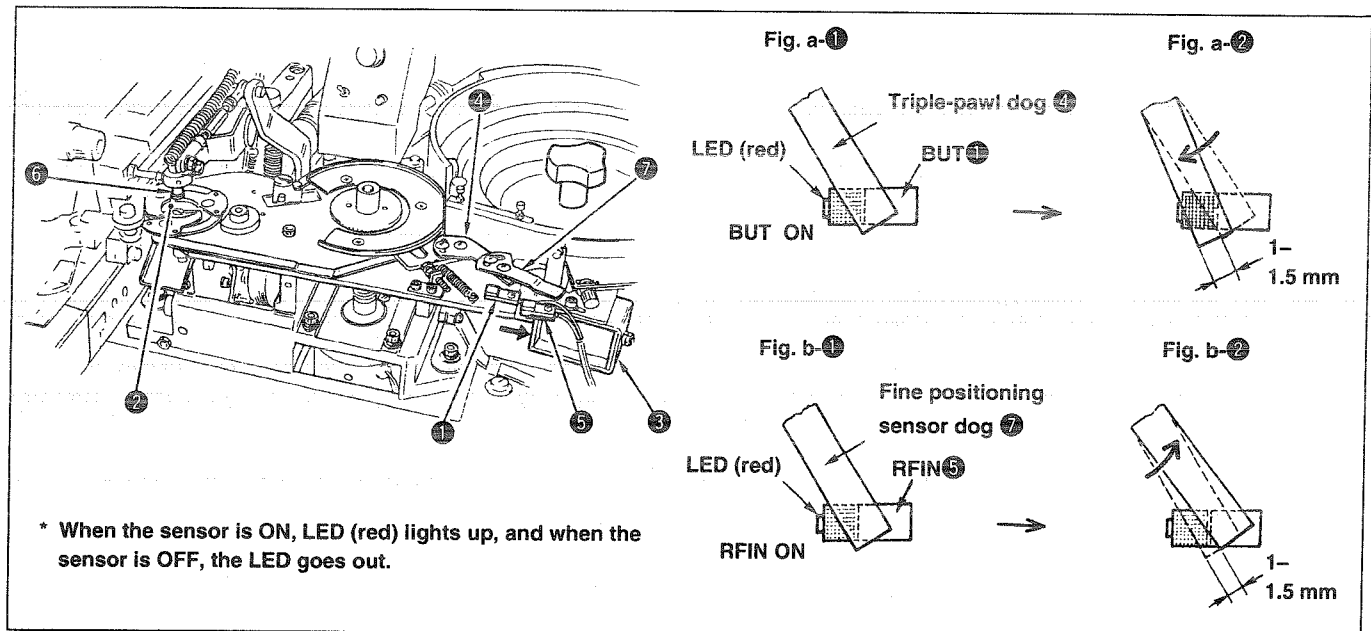

(1) Adjusting the button positioning detection switch (BUT)

Button positioning detection switch ① (hereinafter called BUT) which incorporates a proximity sensor is a sensor to detect whether a button exists within positioner ② when actuating the positioner (triple pawl).

(It turns OFF when a button exists in the positioner or turns ON when it does not detect any button there.)

Draw the iron core of positioning solenoid ③ when there is no button in positioner ②, and the triple pawl will be closed. In this state, loosen the fixing screw of triple pawl dog ④, and move the triple pawl dog until BUT ① which has been in the OFF state turns ON. Then further move the triple pawl dog forward from the aforementioned position (Fig. a-①) by 1 to 1.5 mm (Fig. a-②), and tighten the fixing screw of the triple pawl dog.

Then, confirm that BUT ① turns OFF when the triple pawl clamps a $\phi 10$ mm button. Also confirm that BUT ① turns ON when the triple pawl is closed after taking out the button from it.

Be sure to remember that adjustment (2) should be carried out whenever the aforementioned adjustments have been carried out.

(2) Adjusting the fine positioning completion switch (RFIN)

Fine positioning completion switch ⑤ (hereinafter called RFIN) which incorporates a proximity switch is the sensor to detect a button when the button is set on the carrier pin.

Place a $\phi 10$ mm button in positioner ②, draw the iron core of positioning solenoid ③ to make the triple pawl clamp the periphery of the button. In this state, loosen the fixing screw of fine positioning sensor dog ⑦, and move the RFIN to the position where the RFIN changes from its OFF state to ON state (Fig. b-①). Then move back the RFIN from the aforementioned position by 1 to 1.5 mm (Fig. b-②), and tighten the fixing screw.

Then confirm first that the RFIN turns OFF when the triple pawl clamps a $\phi 10$ mm button. Remove the button from the triple pawl, and confirm that the RFIN turns ON when the triple pawl clamps the periphery of the lower section of the work attachment ⑥.

Note, however, that adjustment (1) should have been completed before starting this adjustment.

(Caution) The RFIN functions to detect a button when the button is completely set on the carrier pin by turning itself ON/OFF (the difference between the outside diameter of the button and that of the work attachment) and to open/close the shutter.

It is not necessary to re-adjust switches (1) and (2) when the current button is replaced with a button of which diameter is different from that of the current button.

12. Adjusting the feed plate of the index unit



WARNING :

Turn OFF the power before starting the work so as to prevent accidents caused by abrupt start of the sewing machine.

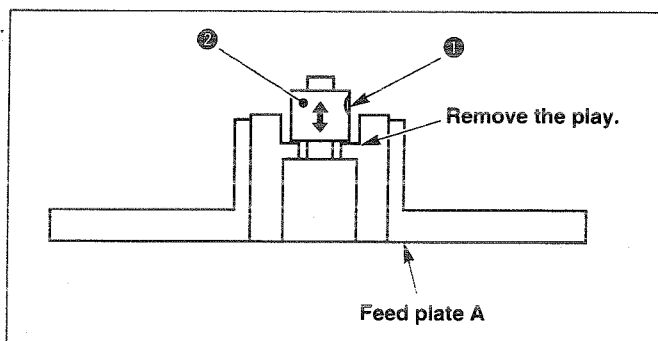
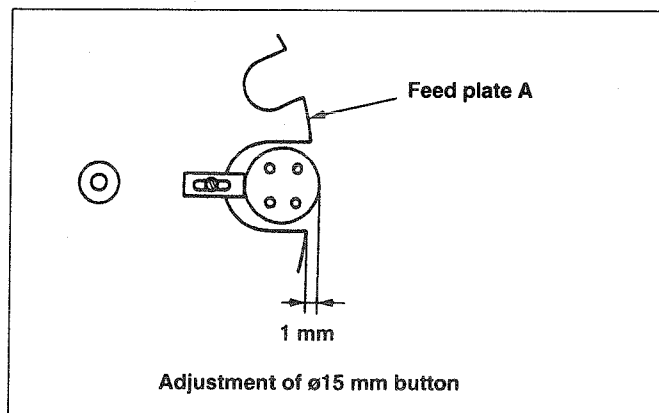
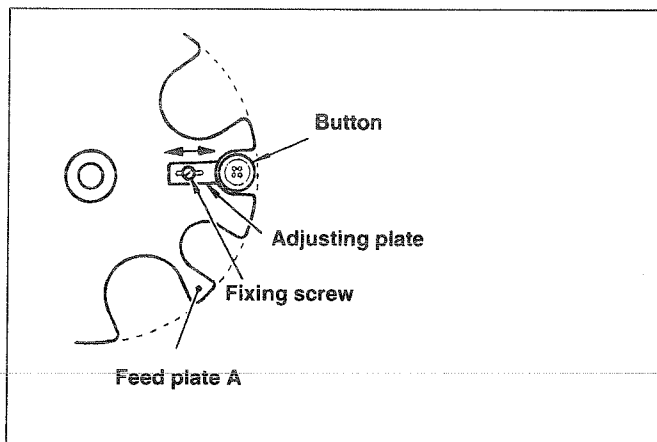
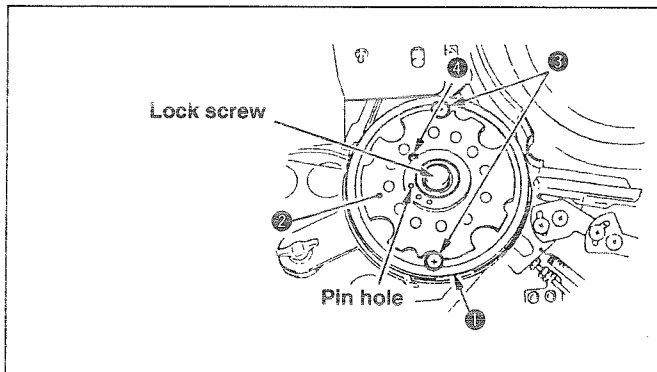

- 1) Confirm that the index unit is in its origin. Then loosen the lock screw, and remove feed plate A. Loosen screws ③ and screw ④, and remove frame ① and adjusting plate ②.
- 2) Select one hole from among three holes with different diameters ($\phi 22$, $\phi 16$ and $\phi 12$) in feed plate A, and finely adjust the hole selected to the buttons to be used using the adjusting plate. Adjust so that the periphery of the button is flush with the periphery of feed plate A.
- 3) Adjust the clearance into which the button is placed using adjusting plate ②. Adjust the clearance to allow only one button to go through it. Once the feed plate is correctly positioned, fix it by tightening screw ④. Close the other holes using frame ①, and fix the frame using screws ③.
- 4) Install feed plate A which has been properly adjusted on the feeder. At this time, be careful to set feed plate A so that the button hole in feed plate A to be used meets the outlet of the feeder bowl. Then tighten the lock screw.

(Caution)

Tighten the screw with care since the screw is likely to break.

When sewing a $\phi 15$ mm button, protrude the adjusting plate by 1 mm from the aforementioned setting of the adjusting plate. (To smoothly drop the button into the index gear.)

When there is a vertical play on the feed plate A, loosen setscrew ①, and strike the lock collar ② to the feed plate A to remove the play. After removing the play, tighten screw ①.

(Caution)

Be careful not to excessively strike lock collar ② to the feed plate A.

13. Replacing the button feeder components and positioning them



WARNING :

Turn OFF the power before starting the work so as to prevent accidents caused by abrupt start of the sewing machine.

(1) Replacing the button carrier and positioning it

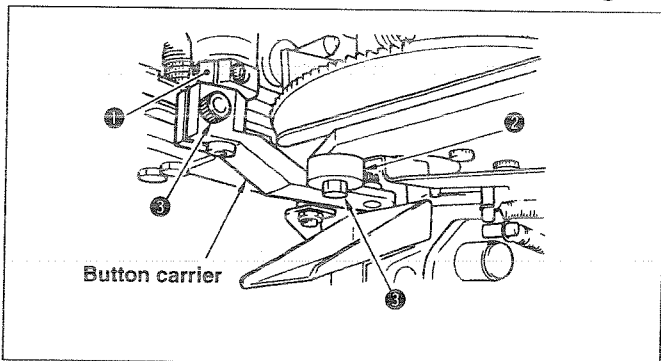

To replace the button carrier, loosen screw ③, then remove the button carrier. Replace the button carrier with one with a proper center-to-center distance, and fit the button carrier with a proper center-to-center distance to eccentric cam ②, and simultaneously make the top face of the carrier come in contact with nut ①. Now fix the carrier by screw ③.

(Caution)

The above-stated positioning procedure should be carried out with the sewing machine set to the origin.

(2) Replacing the work attachment

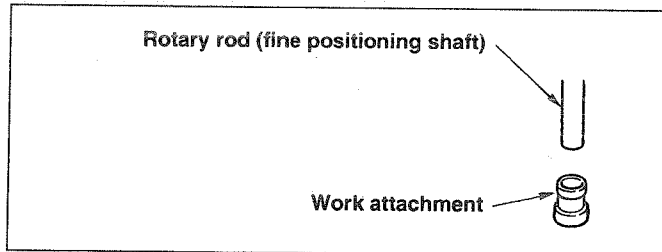

Remove the work attachment currently attached on the sewing machine from the rotary rod. Then attach the work attachment of another type on the machine. At this time, be sure to confirm that the work attachment securely fits in position.

(3) Replacing the feed plate and positioning it

Replacing the pan

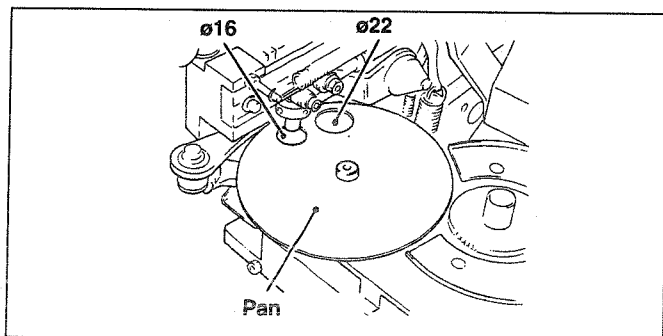
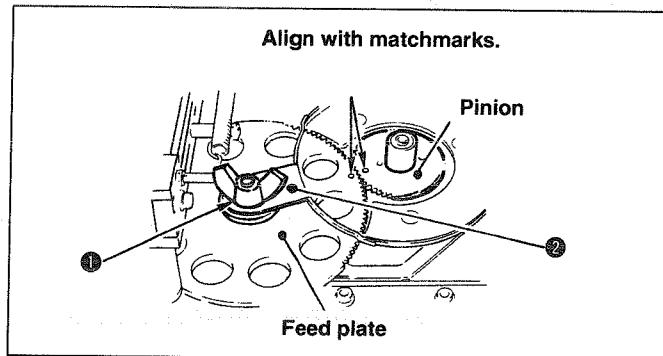

- 1) Remove butterfly nut ①, take out cap ②, and replace the feed plate.

Use the feed plate of $\varnothing 16$ mm when sewing buttons of which diameter is $\varnothing 10$ to $\varnothing 15$ mm. If the outside diameter of the button is $\varnothing 16$ to $\varnothing 18$ mm, use the feed plate of $\varnothing 22$ mm.

To adjust the position of the feed plate, confirm that the pinion is in its origin and attach the feed plate at the position where the matchmark (countersinking) on the pinion aligns with the matchmark on the feed plate. At this time, align the hole in the pan with the hole in the feed plate on the triple pawl.

- 2) It is necessary to adjust the pan located under the feed plate to the diameter of the hole in the feed plate. The pan is provided with two holes, one is $\varnothing 16$ hole and the other is $\varnothing 22$ mm hole. When using the feed plate of $\varnothing 16$ mm, attach the pan by turning it over so that its $\varnothing 16$ mm hole comes this side with respect to the rotational direction of the feed plate. When using the feed plate of $\varnothing 22$ mm, attach the pan by turning it over so that its $\varnothing 22$ mm hole comes this side with respect to the rotational direction of the feed plate.

- 3) Adjust the initial position of the triple-pawl taking the value which is obtained by adding 1 mm to the diameter of the button hole in the feed plate used as reference.

Make the adjustment using the positioning stopper screw.

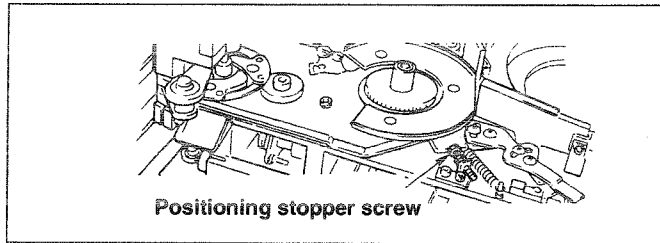
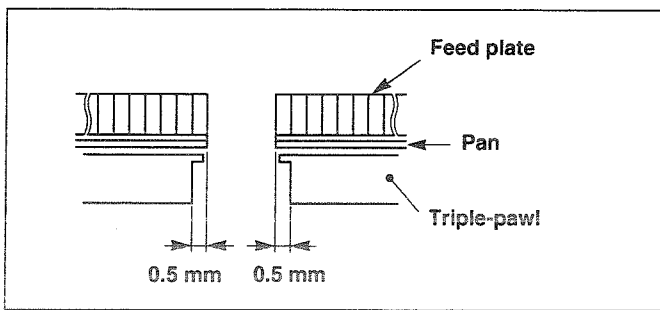

14. Adjusting the vibration of the button feeder

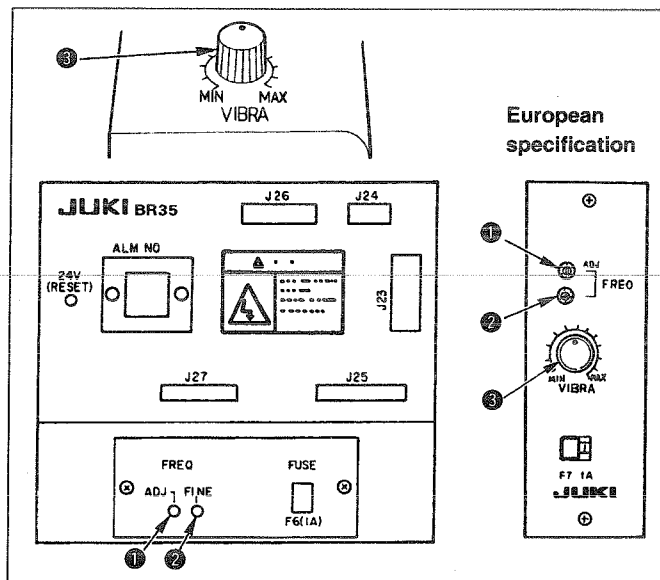

- 1) Turn ON the power to the device.
- 2) Set the button feeder adjusting variable resistor ③ to its intermediate position.
- 3) If the feeder does not vibrate adequately, turn sensitivity adjustment variable resistor ① until it reaches the position to allow the feeder to vibrate most. Then turn sensitivity adjustment variable resistor ② and make a fine adjustment so that vibration of the feeder is maximized.
- 4) Adjust the flow of buttons using the button feeder adjusting variable resistor ③.

(Caution)

Sensitivity adjusting variable resistor ② is very delicate. It is advisable to place buttons with flat bottom in the feeder bowl, and adjust the flow of buttons while checking the actual flow of the buttons. This will allow you to adjust the flow of buttons with ease.

15. Adjusting the feeder bowl components

(1) Guide plate

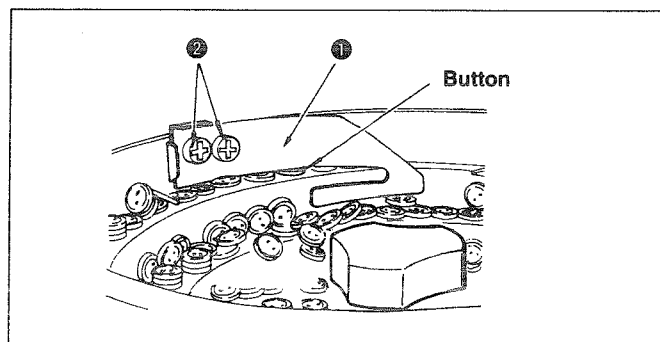

- 1) The appropriate clearance between the button top face and guide plate ① is approximately 0.7 mm.
- 2) Loosen screws ②, and move guide plate ① up and down to adjust the clearance appropriately.

(2) Selector plate

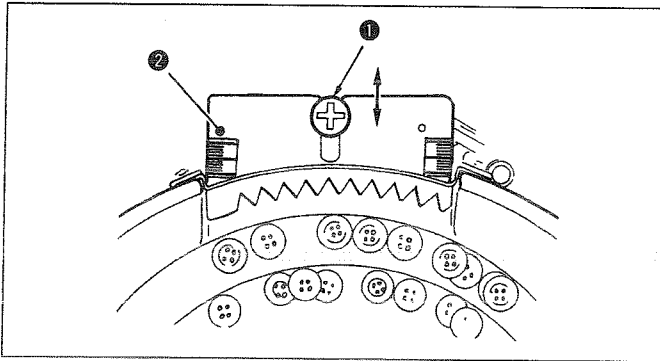

Buttons with their wrong side up are sorted from those with their right side up when they pass the selector plate. So only the buttons with their right side up are fed into the index unit. To adjust the selector plate, loosen screw ①, and move selector plate ② back and forth until it is properly positioned. Then tighten screw ①.

The selector plate comes in two different sizes, medium and small. Select an appropriate one from among the two different types of selector plate in accordance with the size of buttons to be used.

(3) in-line arrangement plate

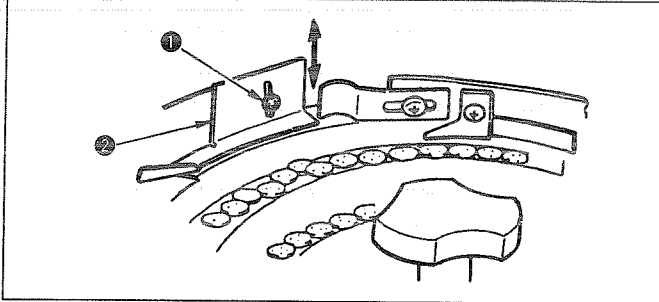

This plate prevents buttons which have passed the selector plate from piling up.

The appropriate clearance between in-line arrangement plate ② and the top face of a button is approximately 0.7 mm.

Loosen screw ①, and move in-line arrangement plate ② up or down to adjust the clearance to the correct value.

(4) Button guide

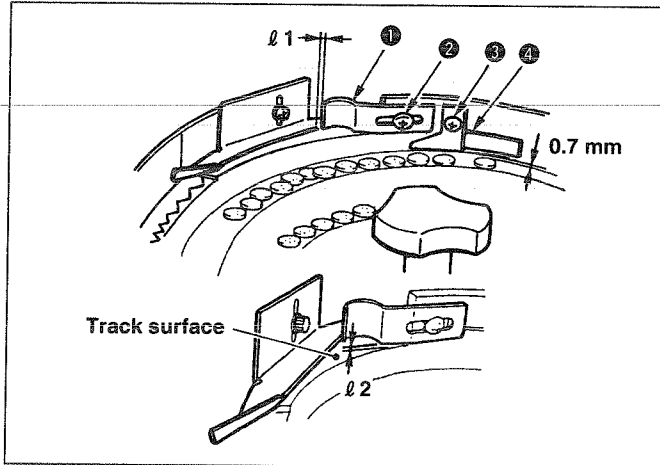

Appropriate clearance “ $l 1$ ” between button guide ① and the button is approximately 3 to 4 mm. Loosen screw ②, and adjust the clearance to the correct value.

Appropriate clearance “ $l 2$ ” between the lower surface of the button guide and the track surface of the feeder bowl is 0.3 to 0.5 mm.

A clearance which is larger than the value twice as thick as a button by approximately 0.7 mm should be provided between overflow prevention plate ④ and the button. Loosen screw ③, and adjust the clearance to the correct value.

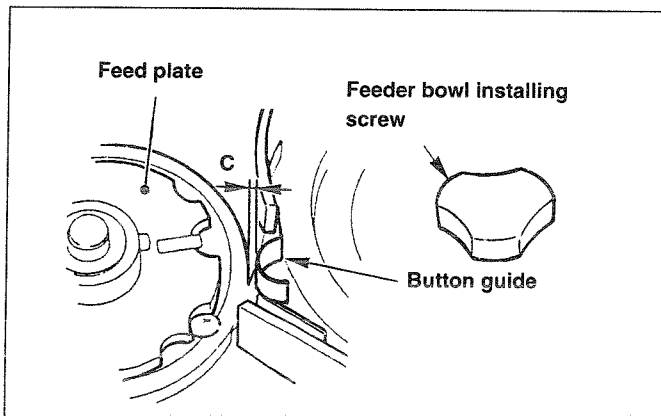

Adjust clearance “ C ” between the button guide and the feed plate to 2 ± 0.5 mm.

Correct the button guide to adjust the clearance “ C ” between the button guide and the feed plate.

(5) Adjusting the position of the feeder bowl

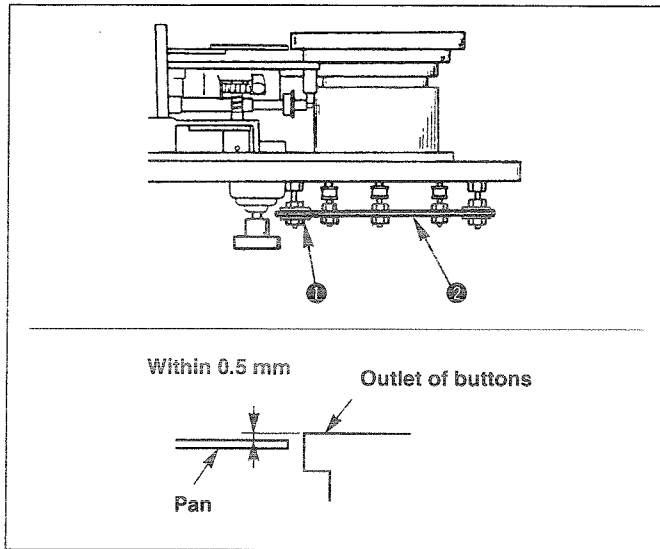

Loosen six lock nuts ① in feeder base ②, and adjust the height so that the feeder bowl comes above when the difference in level between the outlet of buttons of the feeder bowl and the pan is within 0.5 mm.

If the difference in level is excessive, two buttons enter the feed plate in piles. So, be careful.

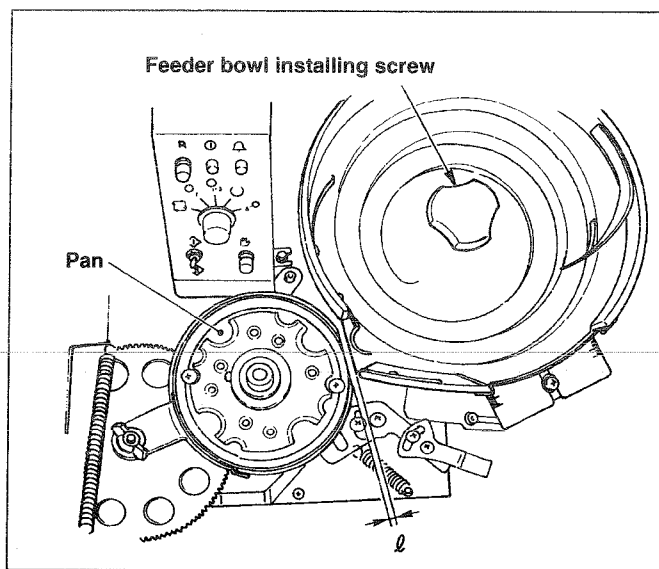

Appropriate clearance " l " between the feeder bowl and the pan is approximately 1 to 1.5 mm.

Loosen adjusting nut ③, and move the whole button feeder to adjust the position.

To make a fine adjustment, loosen the feeder bowl installing screw, and change the position of the feeder bowl.

16. How to replace the buttons (on the button feeder side)



WARNING :

Turn OFF the power before starting the work so as to prevent accidents caused by abrupt start of the sewing machine.

When change of the shape of the button, change of the sewing pattern or enlargement/reduction of the sewing width is performed, make sure of the needle entry point. If the needle extends outside the button hole or the sewing pattern extends outside the button clamp unit, the needle interferes with the button hole or the button clamp unit during sewing, resulting in the danger of the needle breakage or the like.

- The following briefly describes the procedure when replacing the buttons.

(1) When the number of holes in a button changes ()

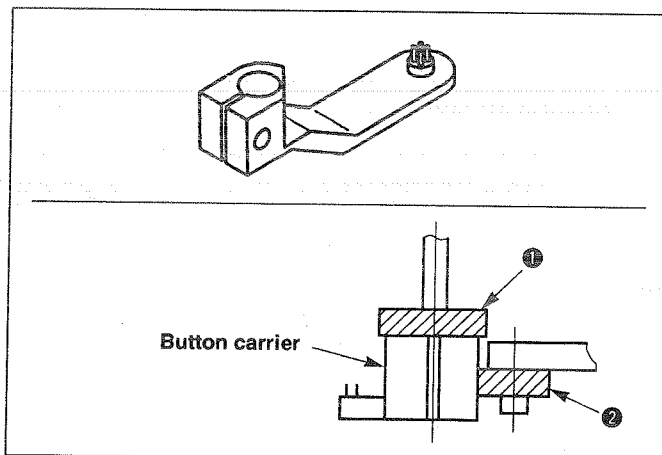

- 1) The button carrier needs to be changed accordingly.
- 2) Set the button carrier to the origin of the button carrier (the position where a button is placed in the button carrier).
- 3) Select the button carrier suited to the button to be used in terms of the number of holes in a button and the distance between the center of holes in a button (hole-to-hole distance).
- 4) Set the button carrier in place while pressing it against stoppers ① and ②.
- 5) Set the pattern No. suited to the shape of button and the sewing width.
Make sure of the needle entry point without fail.

(2) When the button thickness changes ()

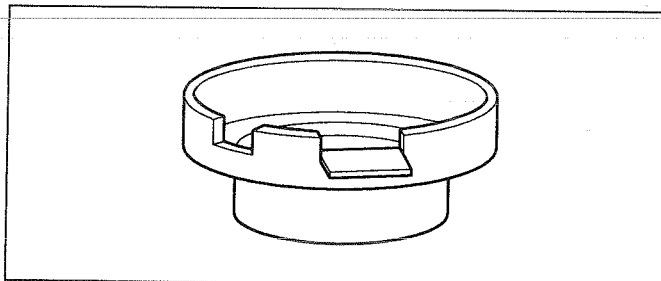

- 1) Adjust so that buttons in the feeder bowl smoothly flow and the selector plate discriminates the right-sided buttons from the wrong-sided buttons without fail.
Refer to "Adjusting the feeder bowl components".

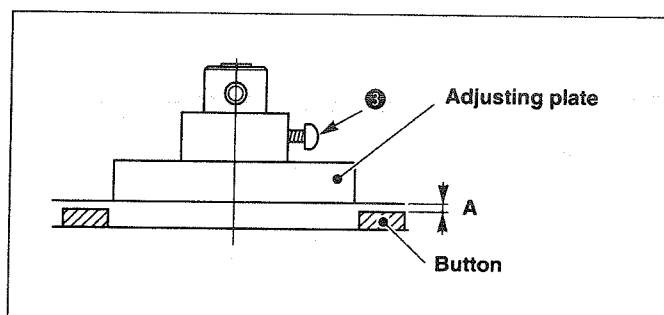

- 2) Adjust the adjusting plate in accordance with the thickness of the button to be used. To adjust the adjusting plate in the vertical direction, loosen screw ③ and set dimension A approximately to 0.7 mm.

(3) When the outside diameter of button changes ($\odot \rightleftharpoons \odot$)

- Adjust so that buttons in the feeder bowl smoothly flow and the selector plate discriminates the right-sided buttons from the wrong-sided buttons without fail.
- Adjust the feed plate A in the radial direction.

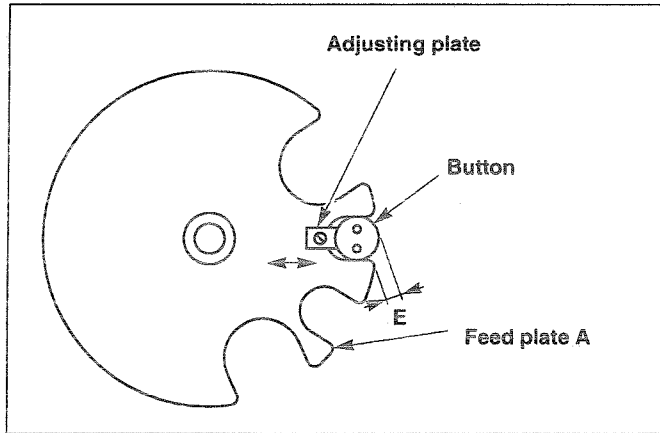

- The feed plate A has three holes with different diameters, i.e., large, medium and small.
 - 1) The small hole is used for buttons of which outside diameter is $\phi 10$ mm to $\phi 11.5$ mm.
The medium hole is used for buttons of which outside diameter is $\phi 11.5$ mm to $\phi 15$ mm.
The large hole is used for buttons of which outside diameter is $\phi 15$ mm to 18 mm.
However, the aforementioned outside diameters of the respective holes should be used as reference.
 - 2) Adjust the adjusting plate so that E becomes 0 when setting a button in the hole.
 - 3) When changing over the hole to be used between the small one and the medium one, move the frame of the feed plate A accordingly to allow the button to be used to fit in the hole selected.

(Caution)

Be sure not to excessively tighten the screw in the feed plate A (made of plastic).

[Example]

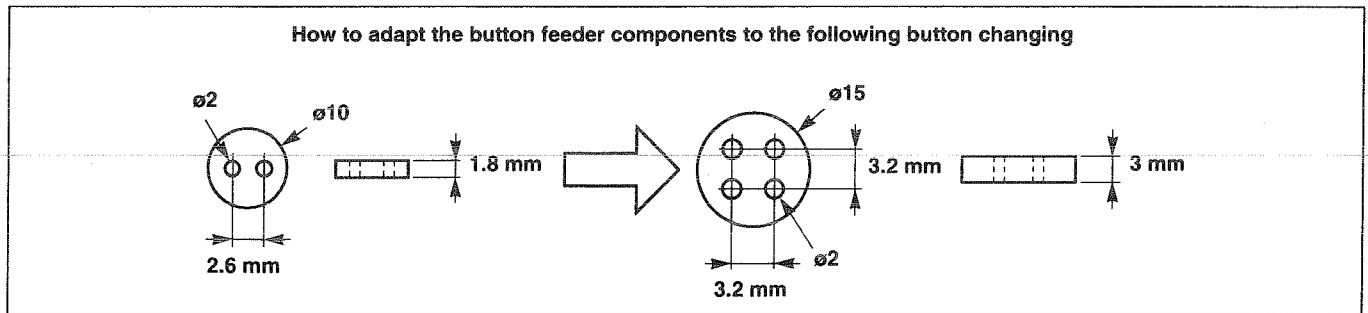



- A. Button carrier and sewing width need to be changed since the distance between the center of holes (2.6 → 3.2) in a button and the number of holes in a button (2 → 4) of the two buttons are different.
- B. The feed plate needs to be adjusted in the vertical direction since the button thickness changes from 1.8 to 3.
- C. The hole of the feed plate to be used needs to be changed from the small hole to the medium hole, and the adjusting plate should be adjusted since the outside diameter of button changes from $\phi 10$ to $\phi 15$ mm.
- D. It is necessary to adjust the feeder bowl components.

Whenever changing the button to be used, check first whether or not the aforementioned changes, A, B and C, in the components are necessary. Then adjust the components, if necessary.

VI. ALARM NO. INDICATION (on the button feeder unit (BR) side)

If the alarm indicator lamp on the operation panel starts flashing on and off slowly, the relevant alarm number indicated on the front face of the control box will be shown on the operation panel.

No.	Indication	Troubles	Causes	Corrective measures	How to reset
0	0	Normal operation (given during the normal stand-by state of the sewing machine)	-	-	-
1	1	RAM check error CPU check error	<ul style="list-style-type: none"> RAM in the CPU circuit board is defective. Self-diagnosis error 	Replace the CPU circuit board.	Re-turn ON the power to the machine.
2	2 (Flash)	Sewing machine starter is defective.	<ul style="list-style-type: none"> If the sewing machine can start up : LK-BR relay cord is disconnected. If the sewing machine cannot start up : 24V breaker trip 	Replace the relay cord.	Press the reset switch. Press the 24V RESET button.
3	3	Fine positioning error Occurs when the automatic button discharging function continuously works three times.	<ul style="list-style-type: none"> The button carrier does not match the distance between holes in the button. The fine positioning completion sensor is defective (malfunction). The centers of the fine positioning rod, of the triple pawl and of the button carrier are not aligned with one another. 	Replace the button carrier. Replace the RFIN sensor. (Adjust the RFIN sensor.) Align the center of the rod with those of the triple pawl and the button carrier.	Press the reset switch.
4	4	Spinner oscillating arm error (The motor is kept turned ON over a predetermined period of time.)	<ul style="list-style-type: none"> Overload of the motor (A button is caught in the spinner oscillating arm or the motor is mechanically locked.) F4 (6.3A) fuse has blown. 	Remove the button. (Refer to "Cautions during operation".) Replace the fuse.	Turn OFF the power to the machine, remove the cause of trouble and re-turn ON the power to the machine.
5	5	Index unit error (The motor is kept turned ON over a predetermined period of time.)	<ul style="list-style-type: none"> Overload of the motor (A button is caught in the spinner oscillating arm or the motor is mechanically locked.) F5 (2A) fuse has blown. 	Remove the button. Replace the fuse.	Turn OFF the power to the machine, remove the cause of trouble and re-turn ON the power to the machine.
6	6	Not used.	-	-	-
7	7	Not used.	-	-	-
8	8	Switch for the positioning of button is defective, or performs malfunction.	-	Re-adjust the button positioning switch. Replace the button positioning switch.	Press the reset switch.
9	9	Start switch is defective, or performs malfunction.	-	Re-adjust the start switch. Replace the start switch.	Press the reset switch.
10	10	The sewing machine start condition error (The spinner oscillating arm motor origin switch has not been turned ON.)	<ul style="list-style-type: none"> The origin of the spinner oscillating arm has not been properly adjusted. The motor used to control the spinner oscillating arm is defective. 	Re-adjust the origin sensor properly. Replace the motor for the spinner oscillating arm.	Turn the spinner oscillating arm up to its origin by hand. Press the manual operation switch.
11	11	Not used.	-	-	-
12	12	Not used.	-	-	-
13	13	Fine positioning operating condition error (The index switch has not been turned ON.)	The index unit is not in its origin. (The motor overruns due to a defective motor.)	Replace the motor for the index unit.	Press the reset switch.
14	14 (Flash)	Sewing machine error State that the power is turned ON. State that the work clamp foot is lowered ().	Sewing machine side error Preparation of the operation box has not been completed. Item selection LED of the sewing machine is in the state that the work clamp foot is lowered ().	-	Release of the sewing machine error Press the Ready key. Press the Selection key.

VII. TROUBLES AND CORRECTIVE MEASURES IN BR

Trouble (Phenomenon)	Cause	Corrective measures
1. Thread slips off the needle at the sewing start. Or, the machine starts sewing a button from an intermediate step of button sewing procedure.	<ul style="list-style-type: none"> ① Length of needle thread remaining in the needle is too short. ② The material flops. ③ The wiper does not press the thread. ④ Sewing machine speed is too fast at the start of sewing. 	<ul style="list-style-type: none"> • Decrease the tension of the tension controller No. 1. • Adjust the disk floating amount of the tension controller No. 2. • Use a needle hole guide with a higher boss. • Use a button clamp of which lever plate is thinner than the current one. • Correct the wiper spring. • Increase the number of stitches of the soft-start (memory switch). (Example : 400 → 400 → 400 → 900 →)
2. Needle breakage frequently occurs.	<ul style="list-style-type: none"> ① The needle hits the edge of holes in the button. ② The boss of the needle hole guide comes in contact with the recessed part of the feed plate. ③ The needle used is too thin. 	<ul style="list-style-type: none"> • Adjust the position of the button clamp jaw lever so that the needle enters the exact center of the holes in the button. • Adjust the position of the feed plate so that it does not come in contact with the boss of the needle hole guide. If the sewing size is large for the feed plate used, replace it with the feed plate for medium-size buttons or for large buttons. • Change the needle count in accordance with the sewing product or the holes in the button.
3. The finished state of the wrong side of the material is extremely poor.	<ul style="list-style-type: none"> ① Length of needle thread remaining in the needle is too long. ② The thread catching force of the wiper is excessive. ③ If sewing a button of which wrong side is round-shaped, the stitches on the wrong side of the material are entangled to make a lump of thread. 	<ul style="list-style-type: none"> • Increase the tension of the tension controller No. 1. • Adjust the disk floating timing of the tension controller No. 2. • Decrease the pressure of the wiper spring. • Replace the current button clamp with another one of which lever plate is thicker than the current one.
4. The button is not sewn at the correct position.	<ul style="list-style-type: none"> ① The button is not secured in the correct sewing position. ② The leaf spring of the button clamp excessively works. ③ When using a button of which wrong side is round-shaped, the thread enters the space between the bottom face of the button and the top face of the boss of the needle hole guide. As a result, the button is not fed smoothly. 	<ul style="list-style-type: none"> • Improve the actuation of the button clamp. • Correct the button clamp jaw lever spring so that it increases the retaining force for the button. • Correct the leaf spring so that it does not excessively work. • Replace the current button clamp with another one of which lever plate is thicker than the current one.

VIII. OPTIONAL PARTS

1. Kinds of the button carrier

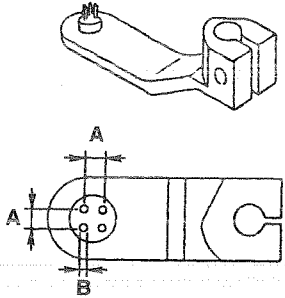



		For 4-holed button		
Shape of button carrier				
	Dimension A (mm) Distance between the holes in a button	Dimension B (mm) Diameter of set pin	Part No.	Code
Standard type	2.6	1.0	165-57902	A
Special order type	2.0	1.0	165-90507	Q
	2.2	1.0	165-90606	R
	2.4	1.0	165-88501	S
	2.4	1.2	165-88600	T
	2.6	1.2	165-88709	U
	2.8	1.2	165-88808	V
	3.0	1.2	165-88907	W
	3.0	1.5	165-89806	F1
	3.1	1.0	165-87206	D
	3.1	1.2	165-89004	X
	3.1	1.4	165-89202	Z
	3.2	Tapered	165-89905	G1
	3.6	1.2	165-90705	H1
	4.0	1.2	165-89707	E1

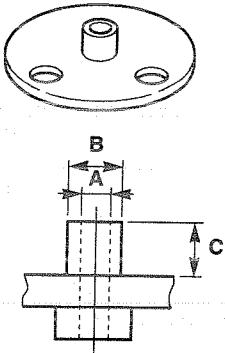
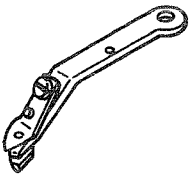
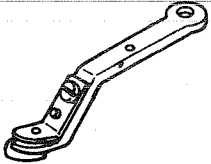

		For 2-holed button		
Shape of button carrier				
	Dimension A (mm) Distance between the holes in a button	Dimension B (mm) Diameter of set pin	Part No.	Code
Standard type	3.2	1.2	165-58009	B
Special order type	2.0	1.0	165-87305	E
	2.2	1.0	165-87404	F
	2.4	1.0	165-87503	G
	2.4	1.2	165-87909	L
	2.6	1.0	165-87602	H
	2.6	1.2	165-88006	M
	2.8	1.0	165-87701	J
	2.8	1.2	165-88105	N
	3.0	1.0	165-87800	K
	3.0	1.2	165-88204	P
	3.8	1.2	165-87107	C

2. Attachment

Name of part	Part No.	Application
Button spacer asm. (Q124) 	MAQ124000A0	It is effective to sew buttons at an equal interval between the buttons. (Including two wood screws) Prepare the spacer for Q124 and fitting screws (2 pcs.) below or a spacer of approximately 25 to 27 mm for adjusting height.
Spacer for Q124 	40018337 SL6041092TN x 2	This is the spacer to install the button spacer (asm.) (Q124) to LK-1903A/BR35. Fix it on the sewing machine table with wood screws supplied with Q124 as accessories. Screws are used to install button spacer (asm.) (Q124) to Q124 spacer.

3. Others

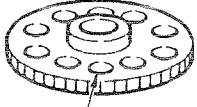
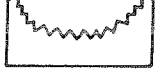
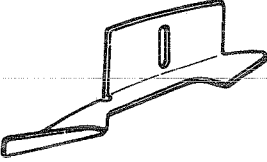
Name of part	Part No.	Application
<p>Needle hole guide</p>  <p>A=1.6 B=3.5 C=1.1</p>	D2426284Y00	Used when there is no gap between the wrong side of button and the needle hole guide.
<p>Button clamp jaw lever asm. for thick buttons, left</p> 	MAZ088220BAA	Used when there is no gap between the wrong side of button and the needle hole guide even when the needle hole guide is replaced with the aforementioned one. (For thick buttons)
<p>Button clamp jaw lever asm. for thick buttons, right</p> 	MAZ088230BAA	Ditto
<p>Work attachment, large</p>  <p>9.5 mm</p>	16557704	The shape of this work attachment is the same as that of the standard type of work attachment and has a large bottom diameter. It is suited to large buttons of which diameter is approximately $\phi 18$ mm. When replacing the standard work attachment with this work attachment, re-adjust the fine positioning completion switch.
<p>Work attachment (with a groove)</p>  <p>8 mm</p> <p>Bottom surface</p>	18257006	This work attachment has a bottom of which diameter is standard but is provided with a cross groove on the bottom surface. It is suited to special-shape buttons (such as marble buttons) which do not smoothly rotate when using the standard attachment.
<p>Work attachment (with a recessed end)</p>  <p>6 mm</p>	18257105	This work attachment has a bottom of which diameter is standard but has a conic recess on the bottom surface. It is suited to the buttons, such as marble buttons, which have protruded top faces.

Name of part	Part No.	Application
<p>Work attachment (with a recessed end)</p>  <p>9.5 mm</p>	<p>18257204</p>	<p>This work attachment is the same as 18257105 in shape but has a larger bottom diameter. When replacing the standard work attachment with this work attachment, re-adjust the fine positioning completion switch.</p>
<p>Feed plate asm., $\varnothing 13.5$ mm Pan, small (Feed plate asm., $\varnothing 22$ mm)</p>  <p>Hole diameter $\varnothing 13.5$ mm</p>	<p>18200956 18201103 (16568651)</p>	<p>This feed plate has a smaller holes ($\varnothing 13.5$ mm) for carrying buttons when compared with the standard feed plate. When a small button (shell buttons, in particular) of which diameter is $\varnothing 10$ mm is to be fed, the button may be reversed when it is delivered to the triple pawl or crack when the triple pawl is closed in accordance with the shape of the button. To prevent the aforementioned troubles, this feed plate is used in combination with the pan, small. If using buttons of which diameter is $\varnothing 16$ mm or more, use the feed plate asm., $\varnothing 22$ mm. In this case, the standard pan can be used.</p>
<p>Selector plate asm., extra small</p>  <p>(Selector plate, large)</p>	<p>18251553 (GBR01424000)</p>	<p>This selector plate is smaller than the selector plate, GBR011220A0. It is suited to the flat buttons (shell buttons, in particular) of which diameter is approximately $\varnothing 10$ mm since, when using such buttons, the selector plate, small, cannot discriminate the right-sided buttons from the wrong-sided ones with consistency. When using large buttons, use the selector plate, large.</p>
<p>In-line arrangement plate A</p> 	<p>18213207</p>	<p>This in-line arrangement plate is suited when sewing buttons including marble-shaped buttons which are likely to be clogged in the standard in-line arrangement plate. This plate is designed to prevent buttons from being clogged.</p>
<p>Centering ring, large</p> 	<p>16558207</p>	<p>Use this ring when centering the origin of the button carrier, E, F or H.</p>