

JUKI

Lockstitch button sewing machine
with an automatic button feeder

LK-1851-555/BR20

INSTRUCTION MANUAL

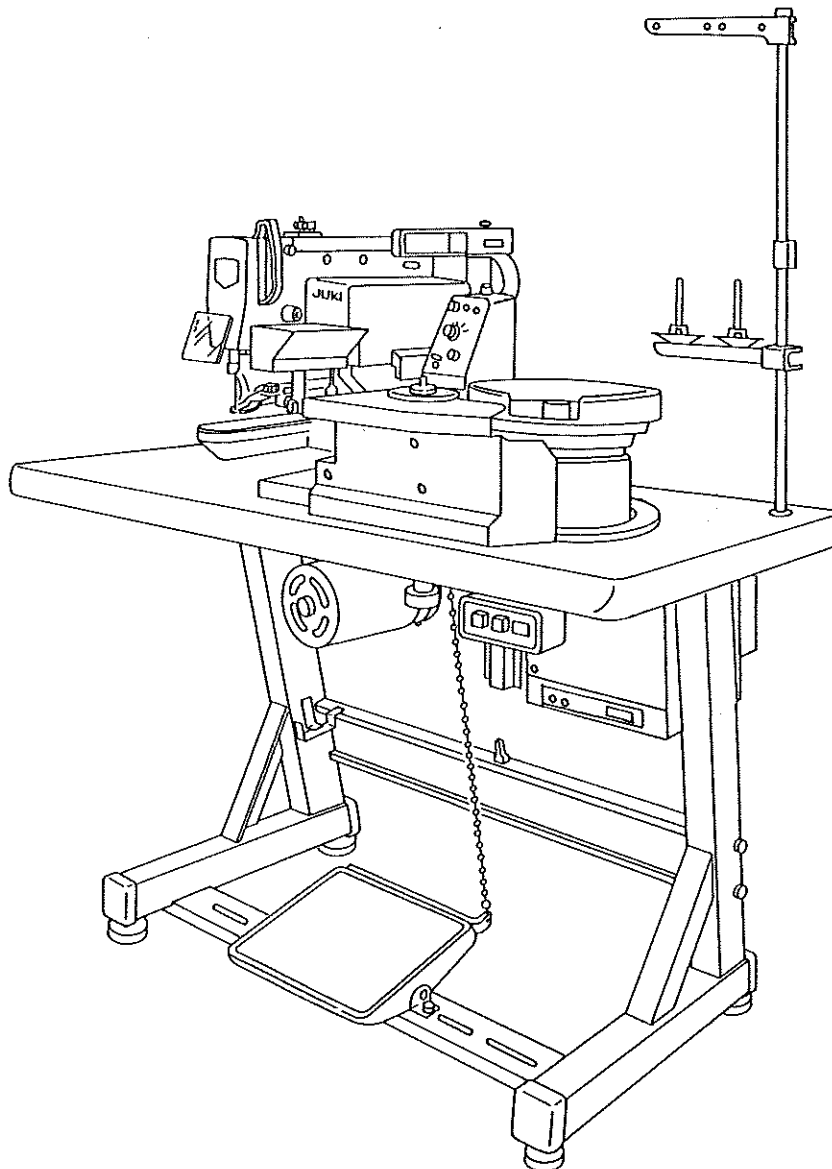

No.01
29038908

FOREWORD

Congratulations on your purchase of the JUKI sewing machine.

Please read this manual carefully before using this sewing machine in order to get the most out of it. You will be rewarded by a long lifetime of reliable service. Refer to the Instruction Manual for the LK-1850 as well as this Instruction Manual when using this machine for the best operating conditions.

BEFORE OPERATION

1. Before applying power, release the stop-motion mechanism and turn by hand the needle driving pulley in order to ensure that the machine is in order.
2. Be sure to lubricate the machine components before starting operation.
3. Make sure that the machine rotates counterclockwise when viewed from the handwheel side. Don't let it rotate in the reverse direction.
(Rotational direction of the machine is indicated on the motor pulley.)

OPERATION CAUTIONS

1. Never put your hand under the needle when you turn ON the power switch or operate the sewing machine.
2. Do not touch the thread take-up with your hands while the machine is running.
3. Be sure to turn the power switch OFF when tilting the machine head or removing the V belt.
4. Never bring your fingers or hair close to, or place anything on the driving pulley, V-belt or motor during operation. It may lead to serious personal injuries.
5. If your machine is provided with a belt cover, eye guard or any other protectors, do not operate your machine with any of them removed.

CONTENTS

1.	FEATURES	1
2.	SPECIFICATIONS	1
3.	NAME OF EACH COMPONENT	2
4.	INSTALLATION AND PREPARATIONS	3
5.	NEEDLE AND THREAD	3
6.	MOTOR PULLEYS AND BELTS	3
7.	THREADING THE MACHINE HEAD	4
8.	CHANGING A NUMBER OF STITCHES	4
9.	ADJUSTING THE SEWING SIZE	5
10.	ADJUSTING THE POSITION OF THE FEED PLATE (for 2-holed buttons)	5
11.	ADJUSTING THE POSITION OF THE FEED PLATE (for 4-holed buttons) AND THE FEED TIMING	6
12.	POSITION OF THE BUTTON CLAMP	6
13.	ADJUSTING THE BUTTON CLAMP JAW LEVER	7
14.	ADJUSTING THE LIFTING AMOUNT OF THE BUTTON CLAMP	7
15.	ADJUSTING THE WORK PRESSING FORCE	7
16.	ADJUSTING THE TIMING OF THE KNOT-TYING PLATE	8
17.	ADJUSTING THE TIMING TO RELEASE THE THREAD TENSION	8
18.	ADJUSTING THE THREAD ADJUSTING DEVICE	9
19.	TROUBLES AND CORRECTIVE MEASURES IN BUTTON SEWING	10
20.	SUBCLASS MODELS AND ATTACHMENTS	11
21.	SPECIAL ORDER PARTS	11
22.	ASSEMBLING THE BUTTON SPACING PIN UNIT (SPECIAL ORDER PART)	12

BR20 AUTOMATIC BUTTON FEEDER

1.	OPERATION	15
2.	HOW TO SET THE DIGITAL SWITCHES AND DIP SWITCHES	18
3.	ERROR MESSAGE AND INSPECTION	21
4.	ADJUSTING THE POSITION OF SENSORS	22
5.	ADJUSTMENTS	24
6.	REPLACING THE COMPONENTS AND POSITIONING THEM	27
7.	OPTIONAL PARTS	28
8.	HOW TO REPLACE THE BUTTONS	29

1. FEATURES

1. This machine is a lockstitch machine, which means that the finished seam does not continuously fray even if the thread end is drawn.
2. Thanks to the unique knot-tying mechanism and the thread adjusting mechanism of this machine, good-feeling seam is provided under a low thread tension. Furthermore, the thread can be securely tied at the sewing end, thereby leading to button sewing with consistency.
3. The button can be sewn with raised uniformly by selecting a button clamp appropriately.
4. Change-over between 4-holed and 2-holed button can be carried out by a finger tip control.

2. SPECIFICATIONS

1. Mechanical specifications

- | | | |
|--|-------------|---|
| 1) Machine head | : | LK-1851-555 (Series) (exclusive machine head) |
| 2) Sewing speed | : | Normal 2,000 s.p.m.
Max. 2,200 s.p.m. (only when using the Z165 (for small buttons) and cotton thread or spun thread) |
| 3) Needle | : | DP x 17 #14 |
| 4) Buttons | Kind : | Flat buttons (2-holed, 4-holed) |
| | Size : | Ø10 to Ø15 mm
(When using a button of Ø16 mm to Ø18 mm, the feed plate 22B (part number : 16568602) should be used.) Refer to "6-(3). Replacing the feed plate and positioning it". (page 27) |
| | Thickness : | t = 1.8 to 3.5 mm |
| 5) Lifting amount of button clamp | : | 11 mm |
| 6) Spacing pin mechanism | : | By a button clamp |
| 7) Stitch adjusting method | : | Crosswise feed : To be adjusted by the one-touch utility lever
Lengthwise feed : To be adjusted by the one-touch utility lever |
| 8) Knot tying mechanism | : | The machine is provided with a forced knot-tying device and a thread adjusting device. |
| 9) Selection of buttons to be fed | : | By vibration system using a piezoelectric feeder |
| 10) Button setting | : | Buttons are loaded from the rear. |
| 11) Individual button feeding method | : | By the index method. |
| 12) Detection of a failure of feeding buttons | : | Provided with two detectors
○ One detector detects a button at the section where the button is correctly positioned.
○ Another detector checks whether the button is correctly inserted into the carrier pin. |
| 13) Driving source for the feeder | : | DC motor (24 Vdc) |
| 14) Function of sewing buttons without cross-over stitch | : | Provided |
| 15) Automatic button discharging function | : | Provided |
| 16) Independent operation of the sewing machine | : | Possible |
| 17) Small-lot sewing function | : | Provided |
| 18) Time required to feed a button | : | 0.5 sec./pc. |
| 19) Weight | : | 85 kg |

2. Electrical specifications

- | | | |
|-----------------------|---|------------------------------|
| 1) Power requirements | : | |
| 3-phase | : | 200V, 220V, 380V, 415V, 440V |
| Single-phase | : | 110V, 220V, 230V, 240V |
| Power fluctuation | : | Rated value ± 10% or less |
| 2) Power consumption | : | 300W |

3. NAME OF EACH COMPONENT

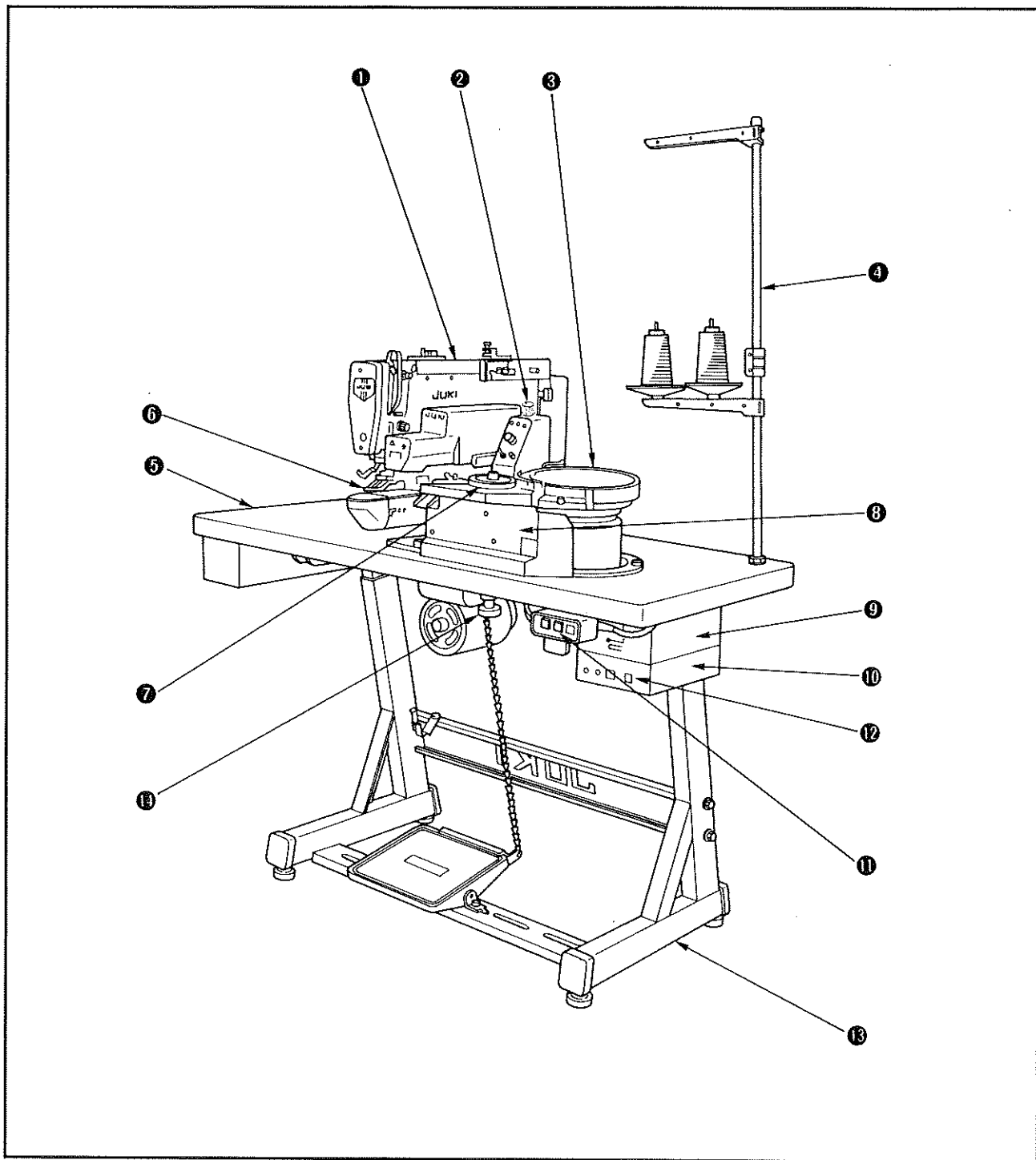

- | | |
|-----------------------|-----------------------|
| ① Sewing machine | ⑧ Front cover |
| ② Operation panel (1) | ⑨ Control box |
| ③ Feeder | ⑩ P/F controller |
| ④ Thread stand | ⑪ Power switch |
| ⑤ Table | ⑫ Operation panel (2) |
| ⑥ Button clamp unit | ⑬ Pedestal |
| ⑦ Index unit | ⑭ Arm motor knob |

4. INSTALLATION AND PREPARATIONS

1. The machine is installed in the procedure same as that taken when installing the LK-1850 machine head. So refer to the Instruction Manual for the LK-1850.
2. The method of operation of this machine is same as that of the LK-1850.

(Caution) Ensure always that the needle does not hit the button before starting the machine.

5. NEEDLE AND THREAD

Needle	Needle thread	Bobbin thread
DP×17 #14	#60	#80
	#50	#60
	#40	#60
	#60	#60

The needle and thread to be used are determined in accordance with sewing conditions. Refer to the table for the selection of appropriate needle and thread for the sewing conditions given. We recommend to use cotton thread or spun thread for this machine.

6. MOTOR PULLEYS AND BELTS

1. M-type V belts are used for this model of sewing machine.
2. This sewing machine uses two V belts, one for high-speed sewing, and the other for low-speed sewing.
3. The table below show the relation between the motor pulleys and V belts and the sewing speeds.

Frequency	Sewing speed	Part No. of motor pulley	Engraved mark	High-speed V belt	Low-speed V belt
50 Hz	2200 s.p.m.	* 13811104	50-2200	MTJVM005100 (51")	MTJVM004700 (47")
	2000	13531207	50-2000	MTJVM005000 (50")	
	1800	13531306	50-1800	MTJVM004900 (49")	
60 Hz	2200	* 13811203	60-2200	MTJVM005000 (50")	MTJVM004700 (47")
	2000	13531504	60-2000	MTJVM004900 (49")	
	1800	13531603	60-1800	MTJVM004800 (48")	

* The motor pulleys marked with an asterisk (*) are applicable only to the Z165 (attachment for small buttons) with cotton thread or spun thread. Please order separately the motor pulleys when using them under the other sewing conditions than described above.

7. THREADING THE MACHINE HEAD

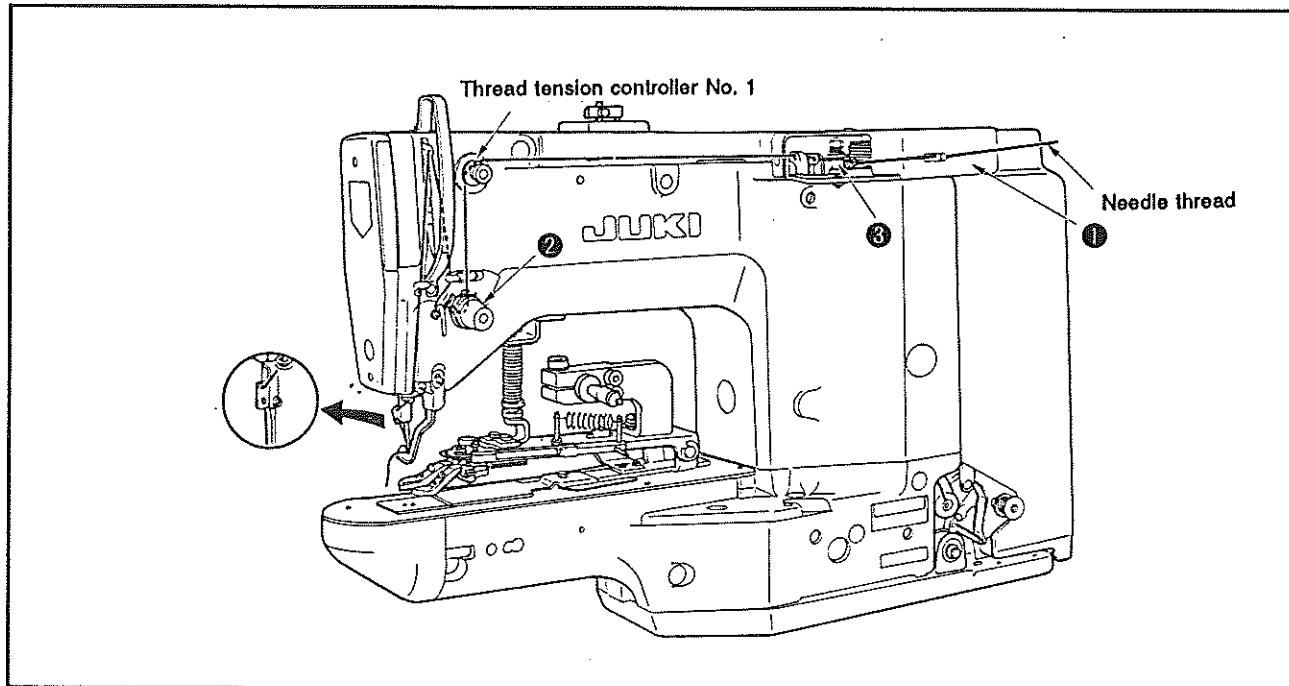

* Thread the machine head in the order as shown in the above figure.

(Caution)

1. Since the machine is equipped with thread adjusting device ① which has been exclusively designed for this machine, operate the machine with the thread tension of thread tension controller No.2 ② reduced to 1/3 to 2/3 of that required by the LK-1850.
2. Thread tension controller ③ fixed on tension adjusting device ① has already been factory-adjusted at the time of delivery, so do not change its setting.

8. CHANGING A NUMBER OF STITCHES

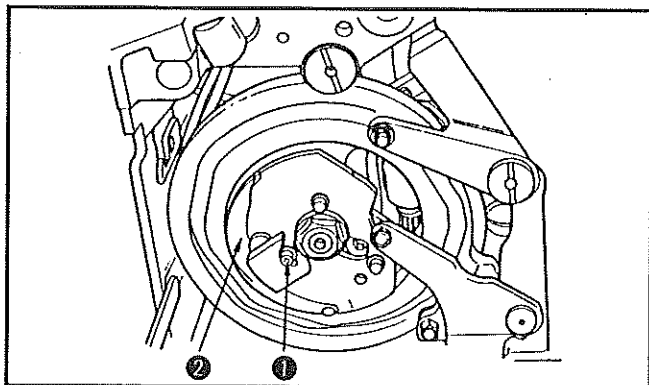

For every subclass model, the number of stitches can be changed as shown in the table below by tilting the machine head, removing screw ① using a hexagon wrench key supplied with the machine and removing one-rotation cam ② .

Subclass model	Number of stitches
LK-1851-555	18 stitches → 9 stitches
LK-1851-558	18 stitches → 9 stitches
LK-1851-556	16 stitches → 8 stitches
LK-1852-557	22 stitches → 11 stitches
LK-1853-559	30 stitches → 15 stitches

9. ADJUSTING THE SEWING SIZE

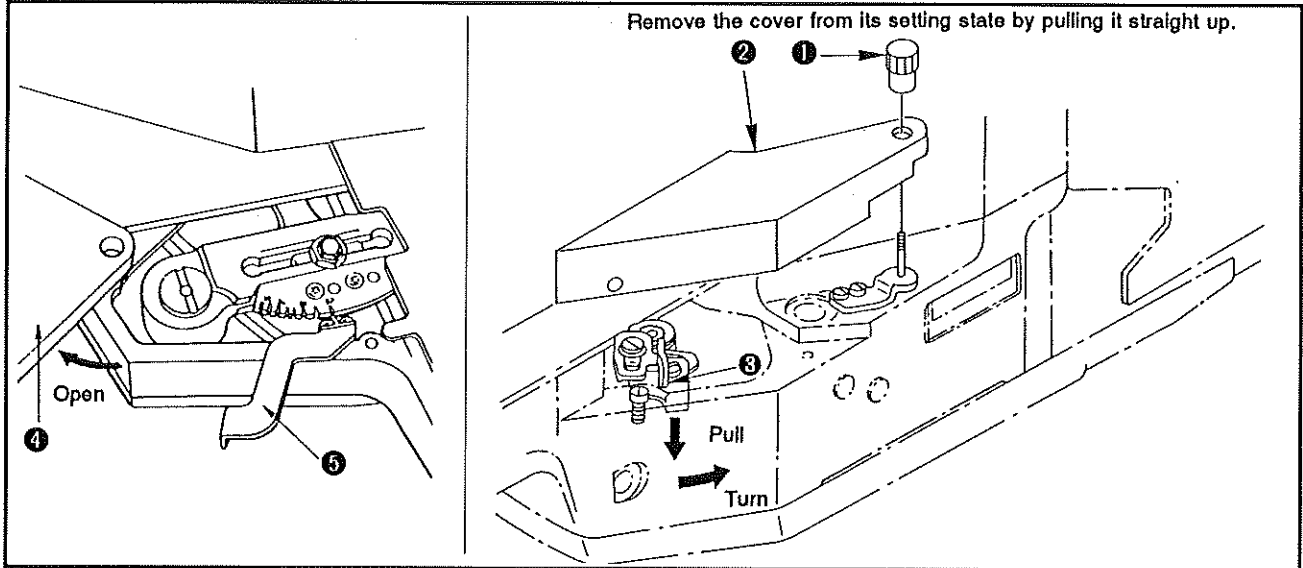

(1) Crosswise sewing size

- 1) Remove knob ① by turning it, and remove bed cover A ②.
- 2) Pull lever ③, and turn it in the direction of the arrow. This will set the machine to the state where adjustment is possible.
- 3) After the adjustment, fix lever ③ by turning it in the direction opposite to the arrow. Then attach bed cover A ② in place.

(2) Lengthwise sewing size

- 1) Open bed cover B ④ in the direction of the arrow. Now the sewing length can be determined by fitting one-touch utility adjusting lever ⑤ in the groove of the scale plate.
- 2) If moving one-touch utility adjusting lever ⑤ to the 2-holed button sewing position, the lengthwise feed amount will be set to 0. Under this state, 2-holed buttons can be sewn. If lowering the button clamp jaw lever, the one-touch utility lever can be operated lightly.

10. ADJUSTING THE POSITION OF THE FEED PLATE (for 2-holed buttons)

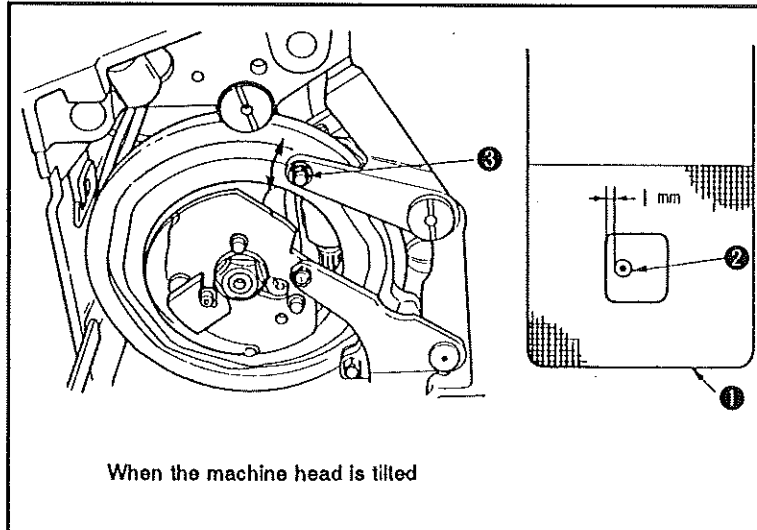

- 1) Set the lengthwise feed one-touch utility lever to the 2-holed button sewing position. If using the Z165 (attachment for small buttons) with the sewing size set to 3 mm, loosen crosswise feeding nut ③ and adjust the lateral position of the feed plate so that a 1 mm clearance is provided between the recessed part of feed plate ① and the boss of needle hole guide ② at the time of the first needle entry.
- 2) Adjust the longitudinal position of feed plate ① by moving it back or forth so that the needle hole guide comes to the center of the recessed part of feed plate ①.

(Caution)

If changing the feed plate or the sewing size exceeds 3 mm, confirm that the recessed part of the feed plate does not hit the needle hole guide at the first and second stitches.

11. ADJUSTING THE POSITION OF THE FEED PLATE (for 4-holed buttons) AND THE FEED TIMING

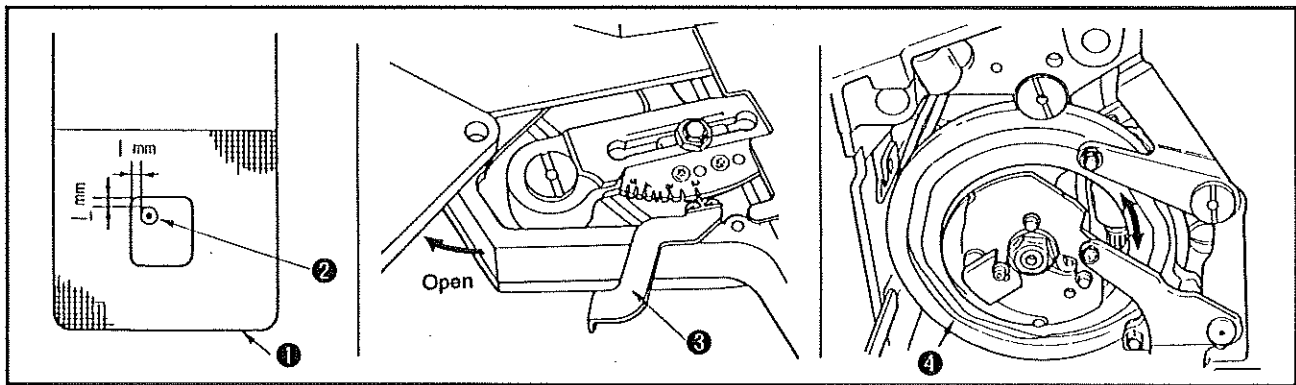

- 1) Adjust the lateral position of the feed plate for sewing 4-holed buttons following the procedure same as that taken to adjust the feed plate for sewing 2-holed buttons. If using the Z165 (attachment for small buttons) with the sewing size set to 3 mm x 3 mm, adjust so that a clearance of 1 mm is provided between the recessed part of feed plate ① and the periphery of needle hole guide ② at the time of the first needle entry.
- 2) Adjust the longitudinal position of the feed plate so that a clearance of 1 mm is provided between the recessed part of feed plate ① and the periphery of needle hole guide ② at the time of the first needle entry by moving feed plate ① back or forth.

(Caution)

If changing the feed plate or the sewing size exceeds 3 mm, confirm that the recessed part of the feed plate does not hit the needle hole guide at the first and second stitches.

- * For the LK-1851-555, LK-1851-556, LK-1852-557 and LK-1851-558, move cloth feed cam ④ in the direction of the arrows (← →) to bring feed plate ① to the position where it does not move back or forth even by moving one-touch utility adjusting lever ③ to the right or left with the button clamp jaw lever lowered when the machine is in its stop-motion state. This adjustment automatically set the feed timing to the correct one. This adjustment makes needle hole guide ② go to the center of the recessed part of feed plate ① when the machine is in its stop-motion state. (Longitudinal direction)
- * Adjust the feed timing of the LK-1853-559 referring to the Instruction Manual for the LK-1850 (20. on page 6).

12. POSITION OF THE BUTTON CLAMP

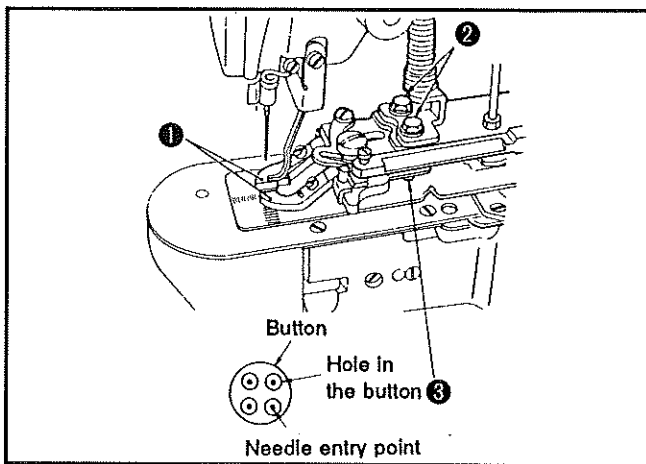

Place a button in between button clamp ①. Then loosen screws ② in the button clamp mechanism base and adjust so that the needle enters the center of the holes in the button with respect to the cross-wise and lengthwise directions when turning the pulley of the reduction gear by hand.

- * To change the raising amount of the button, replace the button clamp ① with the one which has button receiving part of different thickness. In this case, to finish the replacement procedure in a short period of time, remove two screws ③ in the button clamp and replace the button clamp ① with an appropriate one.

13. ADJUSTING THE BUTTON CLAMP JAW LEVER

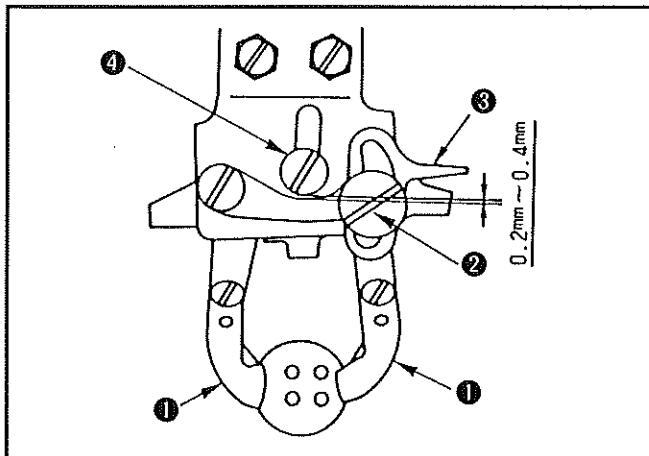

Bring the machine to its stop-motion state. Then lift button clamp ①. Then loosen screw ② in the button clamp jaw lever and adjust so that a clearance of 0.2 to 0.4 mm is provided between button clamp jaw lever ③ and hinge screw ④ when placing a button in between button clamps ①. Then tighten screw ② in the button clamp jaw lever.

14. ADJUSTING THE LIFTING AMOUNT OF THE BUTTON CLAMP

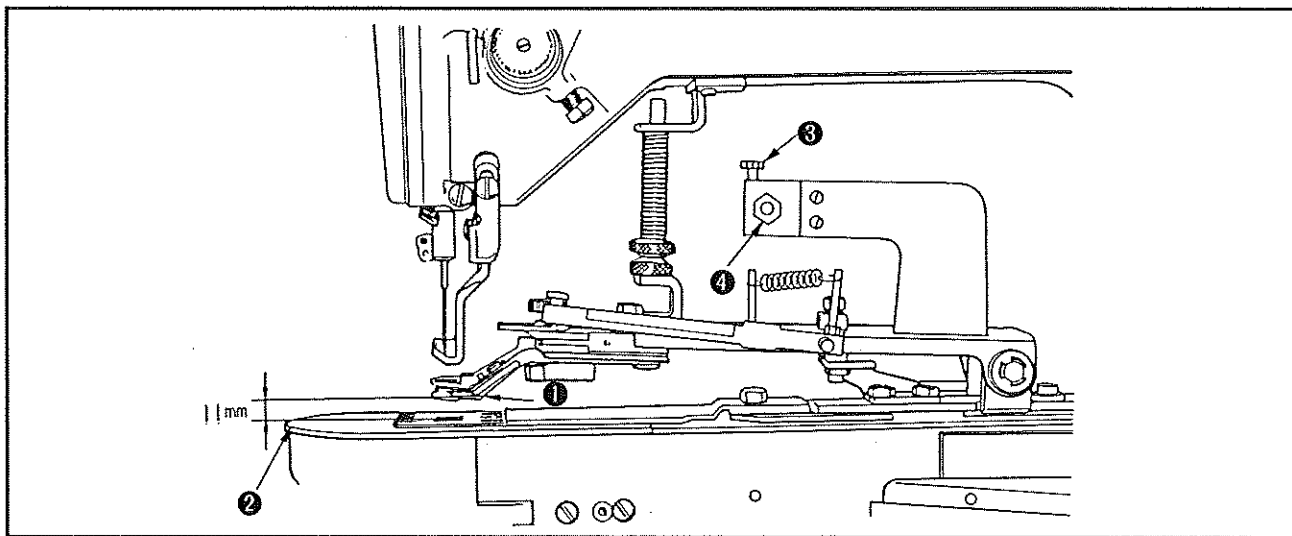

Loosen screw ③, and turn work clamp lifting hook ④ to adjust so that the top end of button clamp ① is 11 mm above the top face of throat plate ② when button clamp ① is in its highest position under the stop-motion state of the sewing machine.

15. ADJUSTING THE WORK PRESSING FORCE

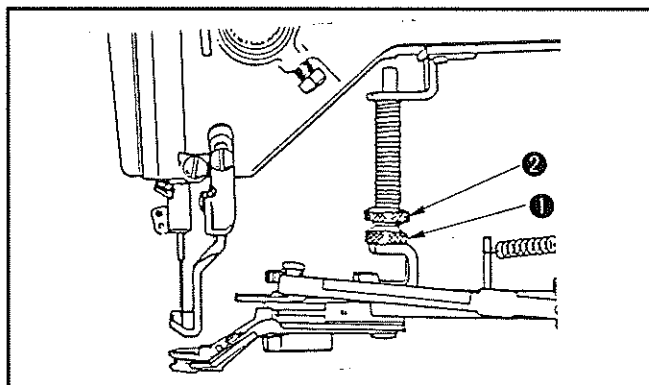

The work pressing force should be minimized as long as the material does not warp during sewing. Loosen adjustment screw ① and turn adjustment screw ② to obtain the aforementioned work pressing force.

16. ADJUSTING THE TIMING OF THE KNOT-TYING PLATE

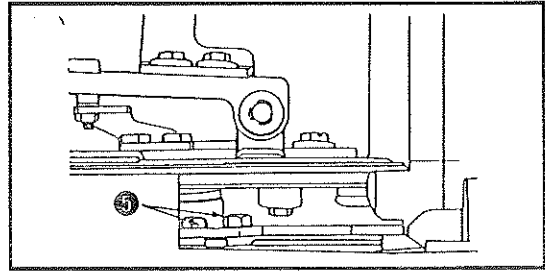
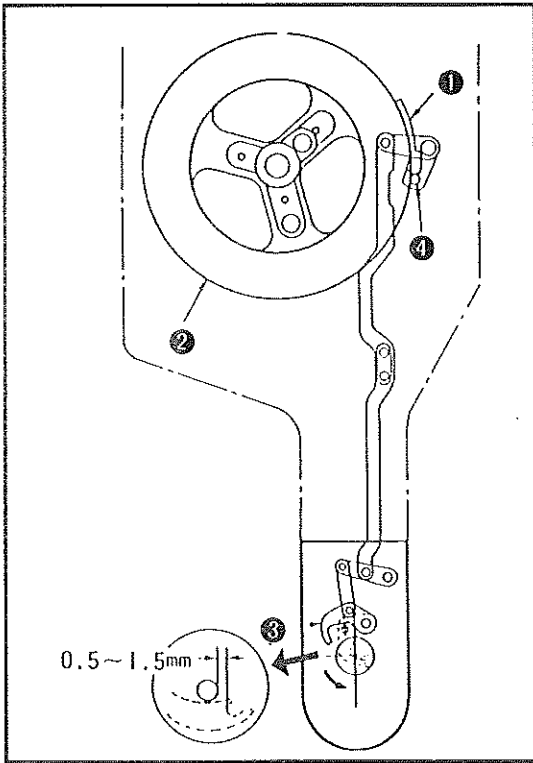

Align the edge of knot-tying notch ① with the marker line engraved on cloth feeding cam ②. As the timing of the knot-tying plate for the cloth feeding cam for 18 stitches, knot-tying plate ③ should come to the position indicated by dotted line before the needle enters the needle hole to make the 17th stitch and knot-tying plate ③ returns to its home position after the needle making the 17th stitch comes out from the needle hole. (For the 22-stitch cam, the knot-tying plate actuates at the 21st stitch. For the 30-stitch cam, it actuates at the 29th stitch, and for the 16-stitch cam, it actuates at the 15th stitch.)

Loosen screws ⑤ in the knot-tying connecting plate and adjust the forward end position (indicated by the dotted line) of knot-tying plate ③ so that a distance of 0.5 to 1.5 mm is provided between the end of the needle hole and the indented part of the hook-shaped threading point. (The knot-tying roller ④ is placed on knot-tying notch ①.)

17. ADJUSTING THE TIMING TO RELEASE THE THREAD TENSION

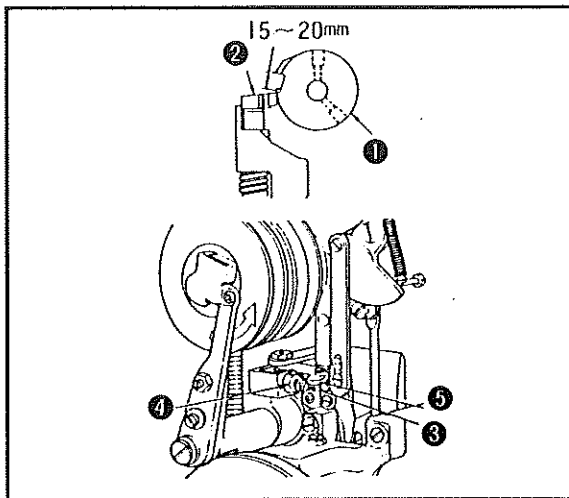

Adjust tension release adjustment screw ③ so that the tension disk starts floating to release the thread tension when stop-motion lever ② reaches 15 to 20 mm before the stop position of stop-motion cam ① before the machine reaches its stop-motion position. Then fix the screw at that position using nut ④.

Tension release adjustment screw ③ presses tension release actuating link ⑤ until it is connected to the thread tension releasing lever. This makes the tension disk float to release the thread tension.

18. ADJUSTING THE THREAD ADJUSTING DEVICE

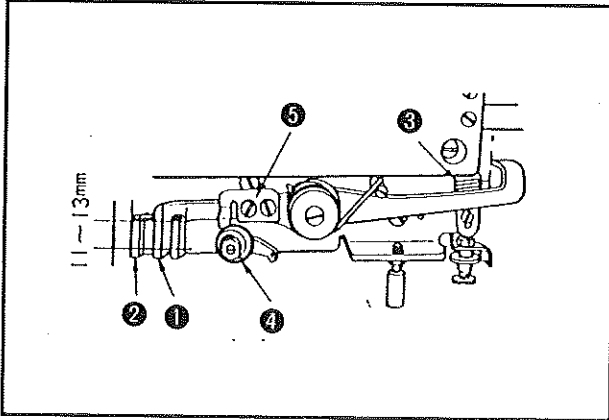



Adjust thread guide ② for the thread adjusting device so that the thread path hole in thread adjusting lever ① and thread path groove in thread guide ② for the thread adjusting device lie on a straight line when the sewing machine runs at high speed.

Then adjust stopper ③ so that a distance of 11 to 13 mm is provided between the thread path hole in thread adjusting lever ① and the thread path groove in thread guide ② for the thread adjusting device when the machine is in its stop-motion state as illustrated in the figure. At this time, adjust tension release lever ⑤ so that the tension disk of tension controller ④ of the thread adjusting device floats to release the thread tension. The thread tension of tension controller ④ of the thread adjusting device is fixed to a uniform value.

19. TROUBLES AND CORRECTIVE MEASURES IN BUTTON SEWING

Trouble (Phenomenon)	Cause	Corrective measures	Page for reference
1. Thread slips off the needle at the start of sewing. The machine starts sewing a button from an intermediate step of button sewing procedure.	<ul style="list-style-type: none"> ① Length of needle thread remaining in the needle is too short. ② The material flops. ③ The wiper does not press the thread. 	<ul style="list-style-type: none"> * Decrease the tension of the tension controller No. 1. * Adjust the tension release timing of the tension controller No. 2. * Use a needle hole guide with a higher boss. * Use a button clamp of which lever plate is thinner than the current one. * Correct the wiper spring. 	<p>8</p> <p>11</p>
2. Needle breakage frequently occur.	<ul style="list-style-type: none"> ① The needle hits the edge of holes in the button. ② The boss of the needle hole guide comes in contact with the recessed part of the feed plate. ③ The needle used is too thin. ④ The needle hits the knot-tying plate. 	<ul style="list-style-type: none"> * Adjust the position of the button clamp jaw lever so that the needle enters the exact center of the holes in the button. * Adjust the position of the feed plate so that it does not come in contact with the boss of the needle hole guide. If the sewing size is too large for the feed plate used, replace it with the feed plate for medium-size buttons or for large buttons. * Change the needle count in accordance with the sewing product or the holes in the button. * Adjust the timing of knot tying and the stroke of the knot-tying plate so that the needle does not come in contact with the plate. 	<p>6 (5)</p> <p>6 11</p> <p>8</p>
3. The finished state of the wrong side of the material is extremely poor.	<ul style="list-style-type: none"> ① Length of needle thread remaining in the needle is too short. ② The thread catching force of the wiper is excessive. ③ Idling amount of the bobbin thread is excessive. ④ If sewing a button of which wrong side is round-shaped, the stitches on the wrong side of the material are entangled to make a lump of thread. 	<ul style="list-style-type: none"> * Increase the tension of the tension controller No. 1. * Adjust the tension release timing of the tension controller No. 2. * Decrease the pressure of the wiper spring. * Use a bobbin case (provided with an idling prevention spring) exclusively used for the LK-1851-555. * Use a button clamp of which lever plate is thinner than the current one. 	<p>8</p> <p>11</p>
4. Knot-tying is not performed with consistency.	<ul style="list-style-type: none"> ① Timing or stroke of the knot tying device is not correct. ② The needle hits the edge of holes in the button. ③ Tension of the tension controller No. 1 is too high. ④ Tension disk of the thread adjustment device does not float at the time of stop-motion. ⑤ When the material sewn has been attached with a reinforced interlining, the needle fails to smoothly come out of the material. 	<ul style="list-style-type: none"> * Adjust the timing of knot tying and the stroke of the knot-tying plate so that the needle does not come in contact with the plate. * Adjust the position of the button clamp jaw lever so that the needle enters the exact center of the holes in the button. * Decrease the tension of the tension controller No. 1. * Adjust the tension disk so that it floats to release the thread tension at the time of stop-motion. * Use a thinner needle. 	<p>8</p> <p>6 (5)</p> <p>8</p>
5. The button is not sewn at the correct position.	<ul style="list-style-type: none"> ① The button is not secured in the correct sewing position. ② The leaf spring of the button clamp excessively works. ③ When using a button of which wrong side is round-shaped, the thread may enter the space between the bottom face of the button and the top face of the boss of the needle hole guide. As a result, the button is not fed smoothly. 	<ul style="list-style-type: none"> * Improve the actuation of the button clamp. * Correct the leaf spring so that it does not excessively work. * Use a button clamp of which lever plate is thicker than the current one. 	<p>11</p>

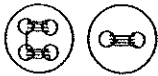
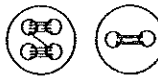
20. SUBCLASS MODELS AND ATTACHMENTS

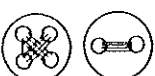
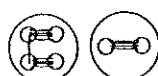
LK-1851-555	LK-1851-556	LK-1852-557	LK-1851-558	LK-1853-559
18, 9 stitches	16, 8 stitches	22, 11 stitches	18, 9 stitches	30, 15 stitches
				
U-shaped stitches	Z-shaped stitches	U-shaped stitches	X-shaped stitches	U-shaped stitches

The following button clamp can be respectively mounted to the aforementioned subclass models as attachments.

Model		Z165		Z166		
Model name (attachment)		For small buttons		For medium-size buttons		
Outside diameter of buttons to be sewn (mm)		φ10 ~ φ20		φ10 ~ φ20		
Sewing size	Length	0 ~ 3.5		0 ~ 4.5		
	Width	2.5 ~ 3.5		2.5 ~ 4.5		
Button clamp	Thickness (mm)	2.2		2.7		
		(2.7)		Engraved mark		
	Part number	Right	MAZ165070B0	H	MAZ166070B0	J
			(MAZ166070B0)	J		
Left	MAZ165080B0	H	MAZ166080B0	J		
	(MAZ166080B0)	J				
Needle hole guide		MAZ15501000		MAZ15601000		

The part of which part number is in parenthesis are supplied with the machine.

* Use the button spacer MAQ124000A0 which has been exclusively designed to be used with the BR20.

21. SPECIAL ORDER PARTS

Use the following special order parts in accordance with applications of the machine.

If sewing buttons of which outside diameter is φ16 mm or more

Button clamp for large buttons (right) MAZ0882300A

Button clamp for large buttons (left) MAZ0882200A

If there is no clearance between the wrong side of the button and the needle hole guide

Needle hole guide D2426284Y00

If you need to raise the button higher

Button spacing pin unit 13810551

Presser bar lifting lever actuating plate for

button spacing pin unit 13811807

22. ASSEMBLING THE BUTTON SPACING PIN UNIT (SPECIAL ORDER PART)

If the button clamp supplied with the machine does not raise the button sufficiently, the button spacing pin unit can be used to further raise the button.

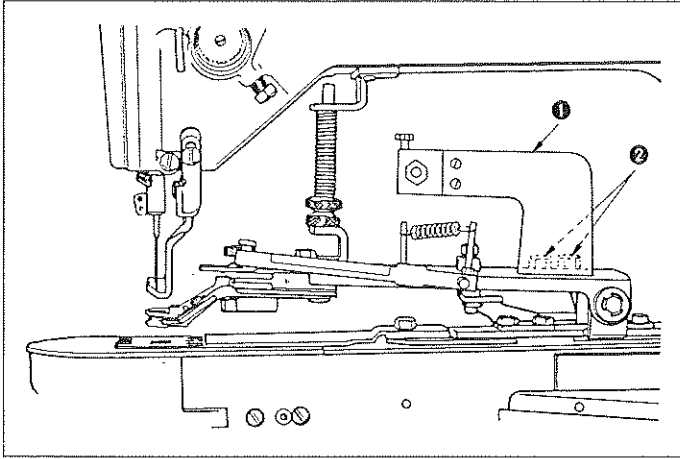

- 1) Remove screws ②, replace presser bar lifting lever actuating plate ① with that for the button spacing pin unit.

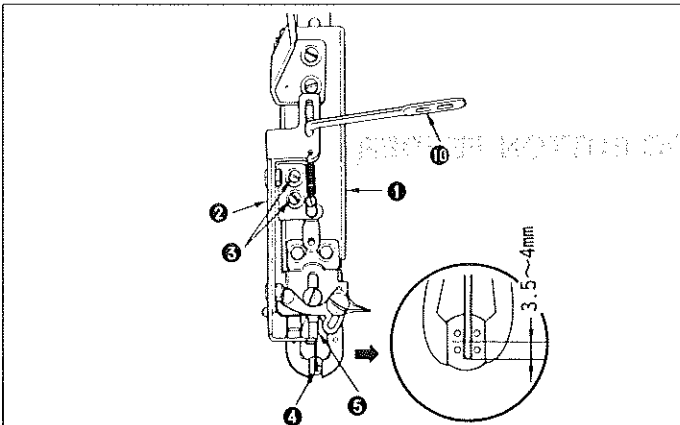

- 2) Attach button spacing pin unit ② on button clamp mechanism base ① using hexagonal screw ③. At this time, button spacing bar ④ should smoothly enter the slip in guide foot ⑤. (Carry out this procedure with the work clamp foot of the sewing machine lowered.)
- 3) Adjust the position of stopper ⑥ so that button spacing bar stops when it moves from the center of the button by 3.5 to 4 mm toward you. Then tighten screws ⑦.

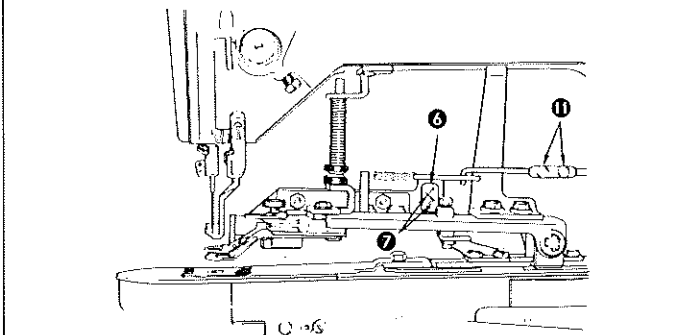

- 4) Remove the rubber plug located at the center of the sewing machine frame to expose the hole in actuating plate ⑨. Then insert link A ⑧ into the hole while turning the link. Insert link B ⑩ into the slot in button spacing pin unit ② so that the link is at the right angles to the slot. Then temporarily fix link A ⑧ and link B ⑩ using screws ⑪.

- 5) Raise the work clamp foot, and tighten screws ⑪ aligning the top end of button spacing bar ④ with the rear end of the holes in the button. At this time, take care not to allow button spacing bar ④ to go back excessively until it comes in contact with the deep end of the slit in the guide foot.

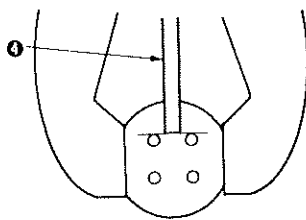
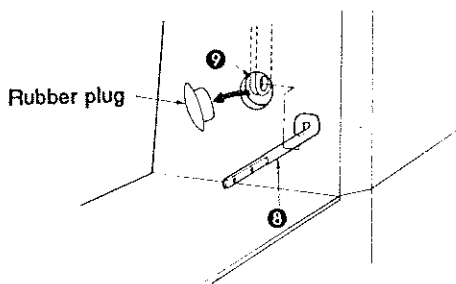

BR20 AUTOMATIC BUTTON FEEDER

Cautions to be taken

1. When the device is set to the "2-holed button sewing" mode, the device cannot sew 4-holed buttons and vice versa. Be careful when starting sewing buttons.
2. When changing buttons to be sewn to those have holes in different positions from the button used at present, replace the carrier with the one suitable for the buttons to be sewn.
Refer to the page 28 for part numbers of button carriers.
3. Adjust the position of the individual button feeding plate according to the size of button to be sewn.
4. Use only buttons specified for the device.
5. The terminal board is located on the right-hand side of the sewing machine motor mounted at the rear section of the unit.
6. Before tilting the machine, be sure to confirm that the carrier arm is in its origin (the position where the button position is determined). If not, turn arm motor knob ❶ until the carrier arm is brought to its origin.

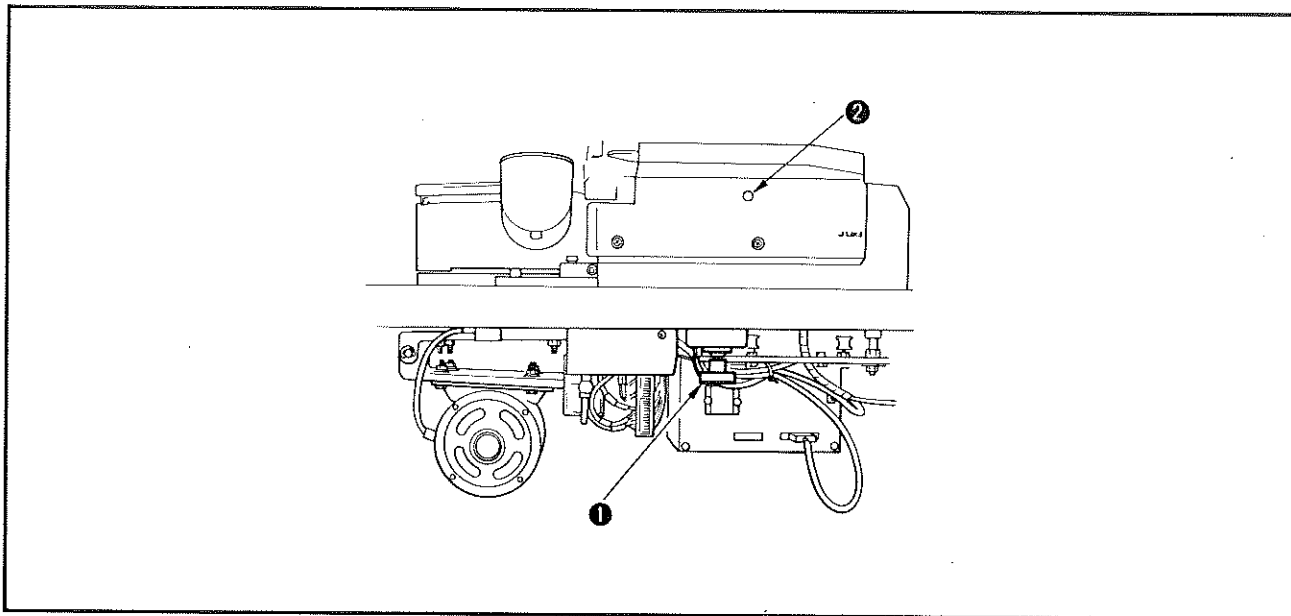

7. When Error "4" indicating an occurrence of a swing arm failure or Error "5" indicating an occurrence of an index unit failure is given, the Reset switch will be inoperative in order to protect the mechanical components. In this case, turn OFF the power to the machine once, and then return ON the power.
8. This machine is equipped with the continuous cycle sewing feature. When you keep depressing the pedal, therefore, the buttons will be continuously fed from the button feeder. So be careful.
9. You can check the function of sensors and respective driving sources.
10. If an error occurs during sewing, the machine will stop running upon completion of the sewing. In this case, the work clamp will be kept lowered. So, press the Reset switch to release the work clamp before you taking out the material from the machine. If the work clamp is not released by pressing the Reset switch, be sure to raise the work clamp by hand.
11. Apply grease on the worm gear and cam periodically (every six months).
12. If tightening screws too firmly in the resin when adjusting the height of the adjusting plate, etc., resin breakage may occur. So be careful.
13. Work attachment comes in two different types, one is the standard type and the other is the large-button type (optionally available). Whenever you have changed the work attachment, be sure to adjust the fine positioning completion switch properly.
14. If a button is caught in the index unit, turn manual rotating shaft ❷ with a flat bit screwdriver and remove the button.

1. OPERATION

(1) Power to the machine and connection of power cables

Connect the power cable coming from the control box of the button feeder to the power supply (R.S.T.E.). When connecting the power to the button feeder, be sure to confirm that the sewing machine turns in its normal rotational direction.

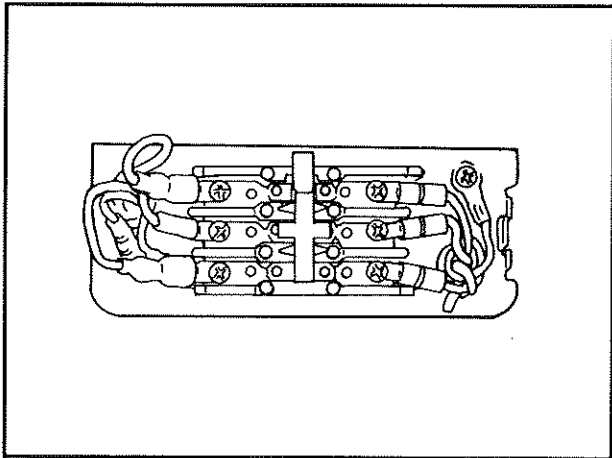

* How to confirm the normal rotational direction of the sewing machine





The sewing machine should turn arrow direction side. If it turns counter-clockwise, change round the wiring of the two power cables of the power supply (R.S.T.).



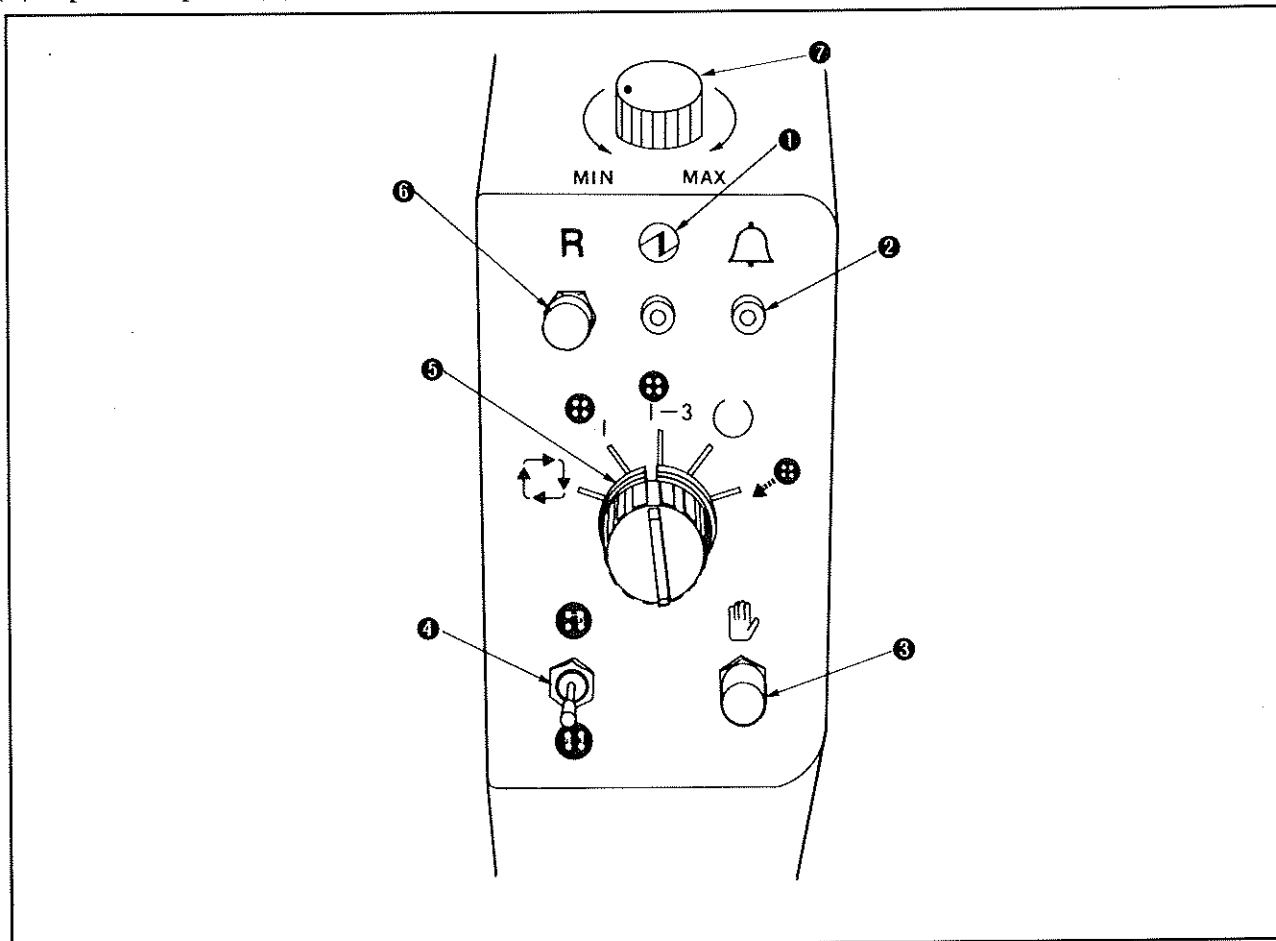



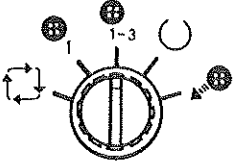

★ Cautions to be taken when the button feeder is connected to the power supply

- 1) Be sure to ground the wire.
- 2) Cautions regarding power supply
 - The fluctuation of voltage of power supply must not exceed the rated value $\pm 10\%$.
 - Abrupt fluctuation of power voltage might stop the machine.
 - If an excessive current load or an electro-magnetic induction by solenoid or the like is applied to the power line, malfunction of the button feeder may result.

(2) Operation panel (1)



Symbol and name of switch	Function
1 Power indicator lamp (green) 	Lights up when the power switch is turned ON. If it fails to light up, check the power plug for secure connection and re-return ON the power switch.
2 Alarm indicator lamp (red) 	This lamp operates in two different ways. It slowly flashes on and off when a failure of the device occurs. (Refer to page 21 "3. ERROR MESSAGE AND INSPECTION".) It quickly flashes on and off when the button sensor mounted on the index unit continuously detects button feeding failure over 10 times.
3 MANUAL operation switch 	Used to manually actuate the series of operations under respective operation modes (2. Independent sewing mode is excluded) which can be selected using mode selector switch 5 .
4 Cross-over stitch selector switch 	Used to change over "with/without cross-over stitches" function. When it is set to its upper side . . . With cross-over stitches When it is set to its lower side . . . Without cross-over stitches (Refer to "(3) Operating the switches for normal sewing work" on page 18 for how to select either "with" or "without" cross-over stitches.)

Symbol and name of switch	Function
<p data-bbox="140 152 411 181">⑤ Mode selector switch</p> 	<p data-bbox="539 159 890 188">1. Automatic sewing mode </p> <p data-bbox="571 203 1390 389">The sewing machine and the button feeder operate with interlocked. Under this operation mode, depressing the pedal lowers the button clamp and makes the sewing machine start sewing a button. When the machine completes sewing of the button, the thread trimmer actuates, then the button feeder actuates to feed next button to be sewn. This series of operations is repeated under the automatic sewing mode.</p> <p data-bbox="539 439 890 468">2. Independent sewing mode </p> <p data-bbox="571 483 1390 645">This mode allows the sewing machine to independently operate. Under this mode, the operator sets the button to be sewn in place on the machine by hand. Then, depressing the pedal lowers the button clamp and makes the machine start sewing the button. When the machine completes sewing of the button, the thread trimmer actuates then the button clamp goes up.</p> <p data-bbox="539 685 855 723">3. Small-lot sewing mode </p> <p data-bbox="571 730 1342 880">Basically, series of operations performed under this mode is same as that under the automatic sewing mode. The parts feeder, however, does not operate under this mode. The operator manually feeds buttons by the number desired to be sewn to the gear of index unit and let the machine perform button sewing.</p> <p data-bbox="539 925 831 954">4. Step-operation mode </p> <p data-bbox="571 969 1390 1189">Under this mode, the spinner oscillating arm performs a step of operation every time operation switch ③ is pressed. If the switch is kept pressed, the spinner oscillating arm continuously perform operation steps. To return the spinner oscillating arm to its origin before completion of the series of operations, first set the machine to any of other operation modes and press manual feed switch ③ again. This will automatically return the spinner oscillating arm to its origin.</p> <p data-bbox="539 1234 879 1263">5. Button discharging mode </p> <p data-bbox="571 1279 1390 1440">Under this mode, buttons in the index unit are automatically discharged by pressing manual operation switch ③. In this case, the button is discharged to the discharging chute located at the lower section of the button positioner. So, place a pan to receive the discharged buttons at the exit area. Do not touch the button clamp since the spinner oscillating arm actuates.</p>
<p data-bbox="140 1473 300 1503">⑥ Reset switch</p> <p data-bbox="284 1529 304 1559">R</p> 	<p data-bbox="523 1480 1390 1541">Press this switch to reset the machine from its emergency stop state to its normal operative state.</p> <p data-bbox="523 1547 1374 1637">(Note that alarms No. 4 and No. 5 cannot be reset using the reset switch. Turn OFF the power once, eliminate the cause of the trouble and re-turn ON the power to the machine.)</p>
<p data-bbox="140 1675 432 1736">⑦ Parts feeder (P/F) adjusting variable resistor</p> 	<p data-bbox="523 1682 1098 1711">Used to adjust the flow of buttons in the feeder bowl.</p>

(3) Operating the switches for normal sewing work

- 1) Turn ON the power to the main unit of the sewing machine.
- 2) Set the mode selector switch on the operation panel to the "automatic sewing" mode.
- 3) Select with/without cross-over stitch.
 - (1) For 2-holed buttons, select "with cross-over stitch."
 - (2) For 4-holed buttons, set the number of stitches to "18" on the sewing machine if you wish for "with cross-over stitch" mode, or to "9" if you wish for "without cross-over stitch."
(Refer to "8. Changing a number of stitches" on page 4 for how to change the number of stitches.)
- 4) Press the manual operation switch, and confirm that a button rest on the button clamp on the main unit of the sewing machine. If the button is not held on the lever, press the manual operation switch again.
- 5) Fully depress the foot pedal, and the sewing machine will start running. Release your foot from the pedal as soon as the sewing machine starts. If you keep depressing the pedal, the machine will enter into the continuous sewing mode. The machine will not enter into the continuous sewing mode, however, as long as the continuous sewing selector switch (DIP switch 1) is set to its OFF position.

2. HOW TO SET THE DIGITAL SWITCHES AND DIP SWITCHES

Loosen two screws ❶, and open panel ❷ as illustrated in the figure. Now, change the setting of digital switches.

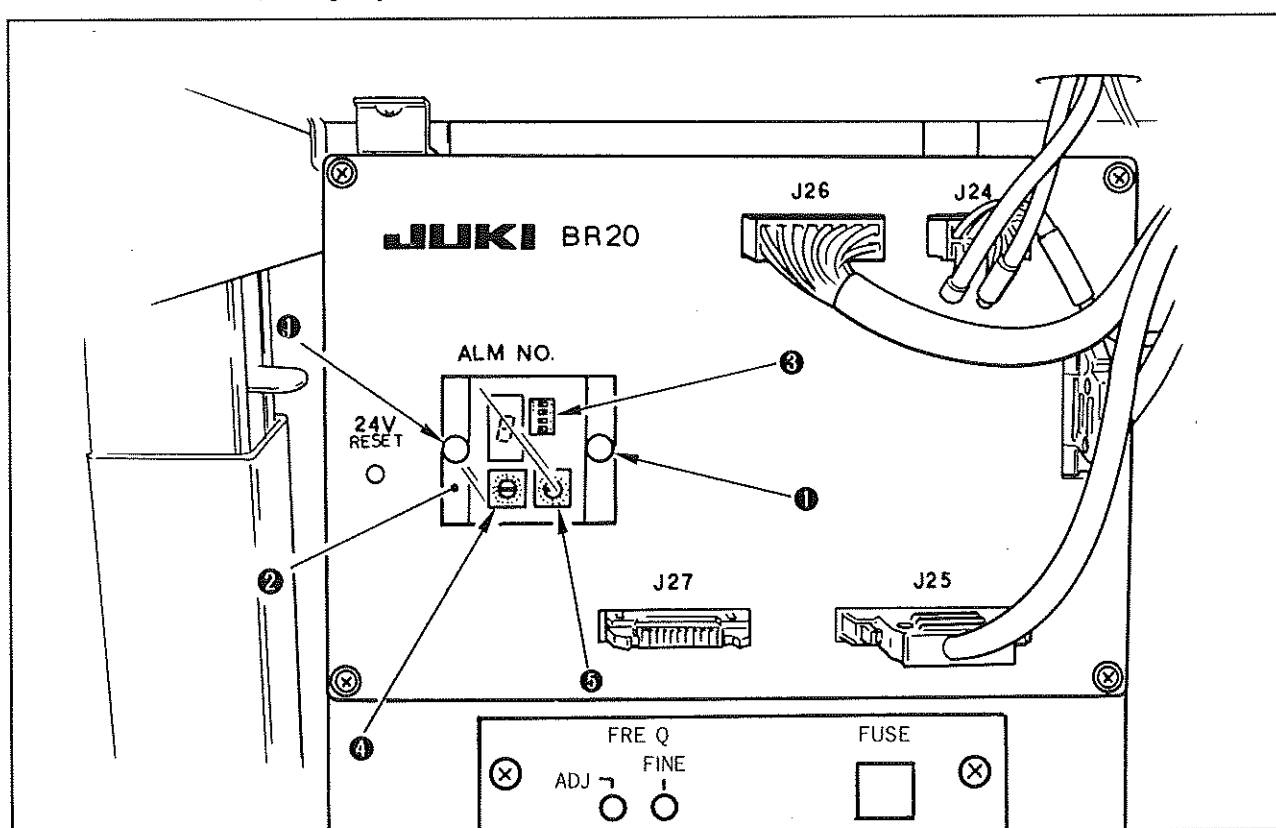

(1) DIP switch function table

Setting of DIP switches at the time of delivery

Function	DIP switch ③			
	1	2	3	4
Continuous cycle mode	○	×	×	×
Double-stepped action of the work clamp	×	○	×	×
Adjustment mode	×	×	○	×
Do-nothing operation of buttons	×	×	×	○

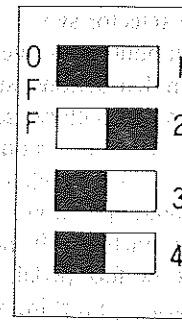

○ : ON
 × : OFF

- a) Continuous cycle mode
 Under this mode, the machine continuously sews buttons on the product as long as the pedal is kept depressed.
- b) Double-stepped action of the work clamp
 This function is described as follows:
 Depress the pedal to the middle depth to make the work clamp come down. In this state, returning the pedal to its initial state makes the work clamp automatically go up. The sewing machine starts running when the pedal is fully depressed.
- c) Adjustment mode
 Under this mode, you can drive each driving mechanism separately by combining the operation switch functions. In addition, the number corresponding to the ON/OFF state of each sensor is indicated on the indicator. However, the machine is set to this mode when turning ON the power to the sewing machine, it is necessary to turn OFF the power to the machine and re-turn ON it after the DIP switch setting has been changed over.
- d) Action without button
 The button detecting sensors are ineffective, and the functions of the sewing machine excluding the button feeder are operative. This function is used to check the performance of the sewing machine.
 (Do not place a button on the sewing machine.)

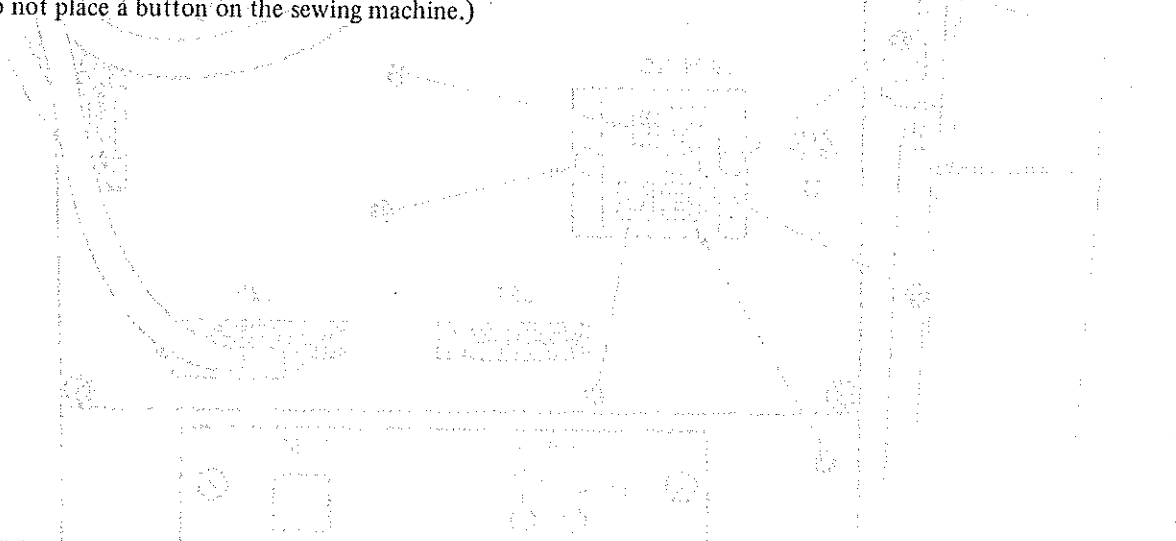

(2) How to set the digital switches

- 1) The length of time from the completion of index to the actuation of the triple pawl can be changed by setting DEG1 ④ accordingly.

Deg 1 — 0	5 msec	8	680
1	85	9	765
2	170 (Factory-set)	A	850
3	255	B	935
4	340	C	1020
5	425	D	1105
6	510	E	1190
7	595	F	1270

(Caution) This switch has been factory-set to 2 at the time of delivery.

The purpose of this switch is to permit the adjustment of the period of time from the completion of index to the actuation of the triple pawl. If using buttons of which wrong side is round-shaped or performing continuous sewing under the continuous cycle mode, the buttons that drop from the feed plate to the shutter plate fail to be secured until the triple pawl actuates resulting in defective feed of buttons to the carrier pin. Furthermore, the button cannot be fed quickly enough from the feeder to the feeding plate of the index unit. As a result, button feeding error may occur. These problems can be prevented by changing the period of time from the completion of index to the actuation of the triple pawl by using the switch.

- 2) The period of time from turning ON the magnet of the triple pawl to the detection of the button can be changed by setting DEG2 ⑤ accordingly.

Deg 2 — 0	50 msec	8	130
1	60	9	140
2	70	A	150
3	80	B	160
4	90	C	170
5	100 (Factory-set)	D	180
6	110	E	190
7	120	F	200

(Caution) This switch has been factory-set to 5 at the time of delivery.

3. ERROR MESSAGE AND INSPECTION

(1) Alarm No. indication

If the alarm indicator lamp on the control panel starts flashing on and off slowly, the relevant alarm number indicated on the front face of the control box will be shown on the control panel.

No.	Indi- cation	Troubles	Causes	Corrective measures	How to reset
0	0	Normal operation (given during the normal stand-by state of the sewing machine)	-	-	-
1	1	RAM check error CPU error	<ul style="list-style-type: none"> RAM in the CPU circuit board is defective. Self-diagnosis error 	Replace the CPU circuit board.	Re-turn ON the power to the machine.
2	2	Sewing machine starter is defective	<ul style="list-style-type: none"> If the machine can start up: L-SW is defective or disconnected. If the machine cannot start up: 24V trip. The starting magnet is defective or disconnected. 	Replace the L-SW. Replace the starting magnet.	Press the Reset button. Press the 24V RESET.
3	3	Fine positioning error (The fine positioning performance is not completed even after the second trial.)	<ul style="list-style-type: none"> The carrier does not match the distance between holes in the button. The fine positioning completion switch is defective. (Malfunction) The center of the fine positioning rod and that of the triple pawl carrier are not aligned with each other. 	Replace the carrier. Replace the RFIN sensor. (Adjust the RFIN sensor) Align the center of the rod with that of the triple pawl carrier.	Press the Reset button.
4	4	Spinner oscillating arm error (The motor is kept turned ON over a predetermined period of time.)	<ul style="list-style-type: none"> Overload of the motor (A button is caught in the spinner oscillating arm or the motor is mechanically locked.) F4 (6.3A) fuse has blown. 	Remove the button. Replace the fuse.	Turn OFF the power to the machine, remove the cause of the trouble and return ON the power to the machine.
5	5	Index unit error (The motor is kept turned ON over a predetermined period of time.)	<ul style="list-style-type: none"> Overload of the motor (A button is caught in the index unit or the motor is mechanically locked.) F5 (2A) fuse has blown. 	Remove the button. Replace the fuse.	Turn OFF the power to the machine, remove the cause of the trouble and return ON the power to the machine.
6	6	-	-	-	-
7	7	When the power switch is turned ON, the stop-motion mechanism is in its OFF state.	-	Set the machine head to its initial state.	Press the Reset switch.
8	8	Push-button switch for the positioning of button is defective or malfunction.	-	Re-adjust the Button positioning switch. Replace the Button positioning switch.	Press the Reset switch.
9	9	Start switch is defective or malfunction.	-	Re-adjust the Start switch. Replace the Start switch.	Press the Reset switch.
10	0	The sewing machine start condition error	The origin of the spinner oscillating arm has not been properly adjusted. The motor used to control the spinner oscillating arm is defective.	Re-adjust the origin sensor properly. Replace the motor for the spinner oscillating arm.	Press the reset switch.
11	3	Button clamp jaw lever lifting condition error	The motor used to control the spinner oscillating arm is defective. The machine is not in its initial position when lifting the button clamp jaw lever.	Replace the motor for the spinner oscillating arm. Set the machine to the initial state.	Press the reset switch.
12	U	Spinner oscillating arm condition error	The machine is not in its initial position when actuating spinner oscillating arm.	Set the machine to the initial state.	Press the reset switch.
13	5	Fine positioning performance condition error (Overrun of the Index)	The index unit is not in its origin. (The machine overruns due to a defective motor.) CPU circuit board is defective.	Replace the motor for the index unit. Replace the CPU circuit board	Press the reset switch.

(2) 24V trip

An overcurrent of the 24Vdc line will trip the breaker mounted on the front face of the control box. To reset, press the white part of the breaker using a thin pin or the like until the part clicks.

(3) Replacing the fuse

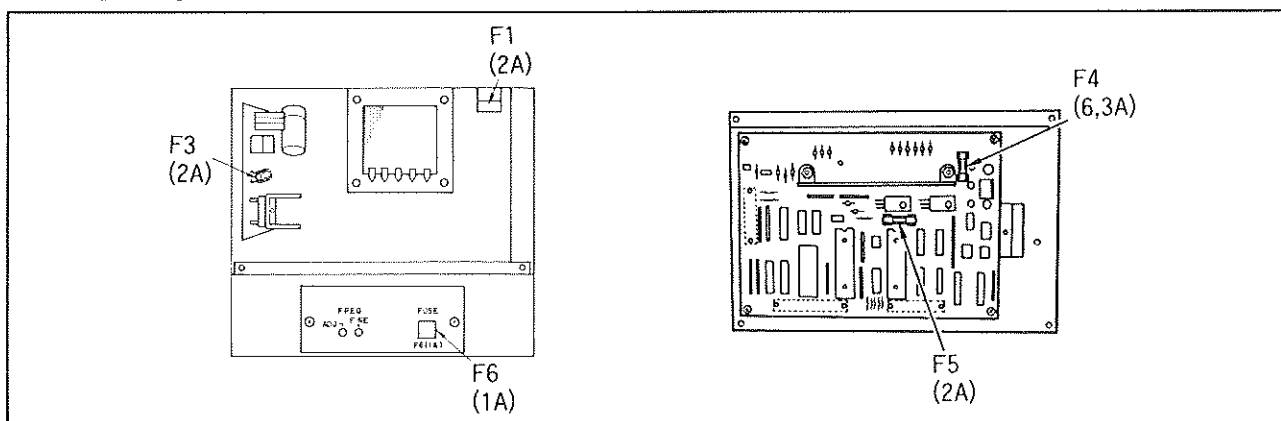

You may find five fuses (F1, F3 through F6) as illustrated in the figure. (Remove the frame cover on the front face of the control box, and replace the fuses.)

4. ADJUSTING THE POSITION OF SENSORS

(Set the mode selector switch on the control panel to the step-operation mode (○).)

(1) Adjusting the start origin switch (SORG)

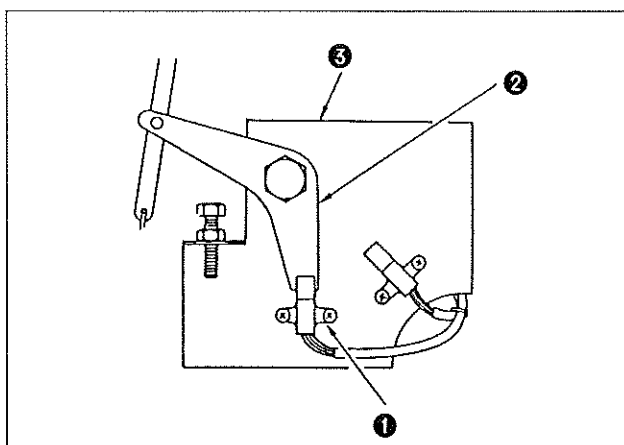

Start origin switch ① (hereinafter called “SORG”) which incorporates a photo micro sensor (PM-T53B) is the sensor to detect the returning action of the foot pedal.

Adjust so that the SORG is shielded when the pedal is returned to its home position after it has been depressed to make the button clamp come down. If the SORG is not shielded, check whether two-stepped switch bracket ③ has been installed correctly. If two-stepped switch bracket has been installed with bent, switch shield plate ② may fail to smoothly operate preventing the SORG from being properly shielded.

(2) Adjusting the start switch (START)

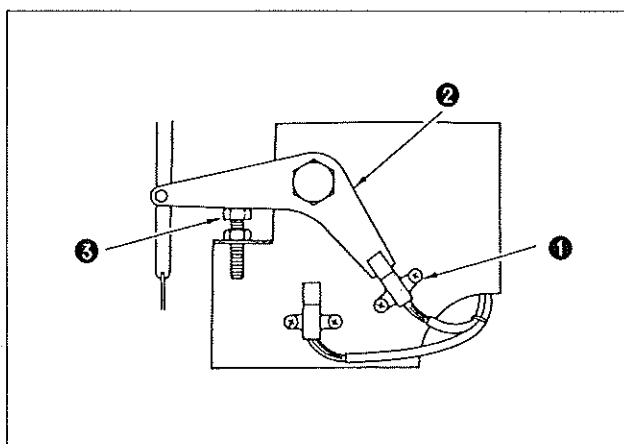

Start switch ① (hereinafter called “START”) which incorporates a photo micro sensor (PM-T53B) is the sensor to detect the depressed foot pedal and to output the command to actuate the sewing machine.

Adjust so that the START is shielded when the pedal is depressed. If the START is not shielded or it overruns after it has once shielded, adjust stopper bolt ③ so that shielded plate ② comes just the center of the sensor.

(3) Adjusting the spinner oscillating arm origin switch (AORG)

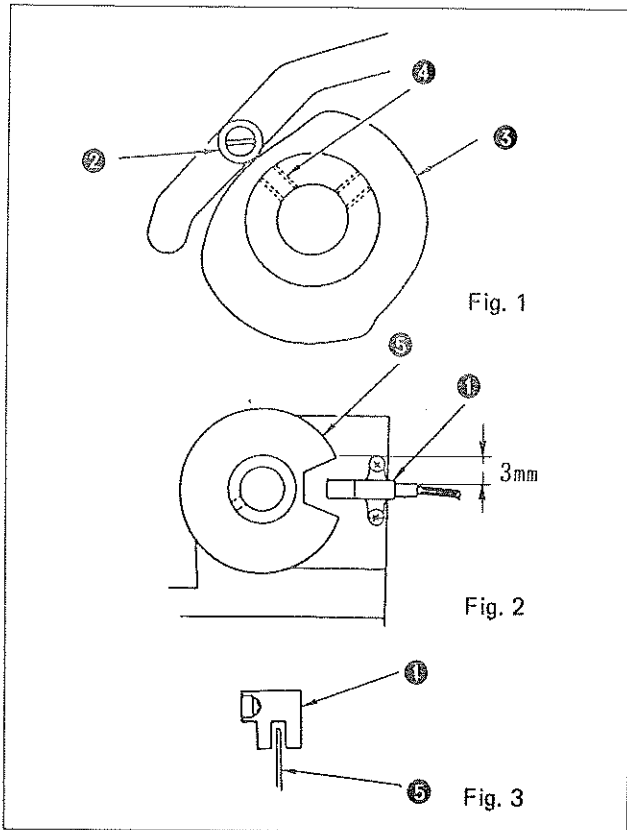

Spinner oscillating arm origin switch ① (hereinafter called "AORG") which incorporates a photo micro sensor (PM-T53B) is the sensor to detect the origin of the cam shaft.

Adjust so that cam follower ② for the button clamp jaw lever is located above attaching screw ④ in two-stepped cam ③ by turning the knob on the motor of the spinner oscillating arm origin switch, as illustrated in Fig. 1. Fix sensor dog ⑤ at that position as illustrated in Fig. 2.

At this time, note that sensor dog ⑤ should come the center of the sensor as shown in Fig. 3.

(4) Adjusting the index origin switch (IORG)

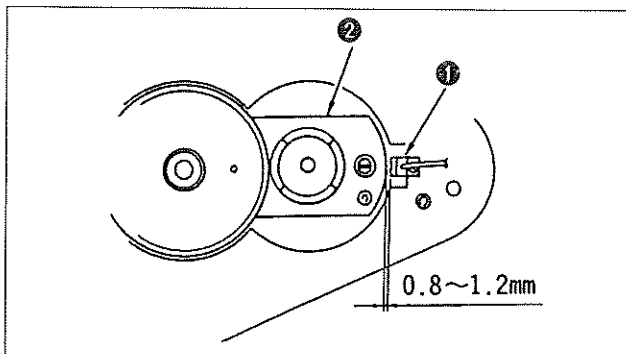

Index origin switch ① (hereinafter called IORG) which incorporates a proximity sensor (GXL-8F) is a sensor to detect the stop of feeding of the feed plate. Adjust the clearance between the periphery of Zeneva wheel ② and the detecting plane of the IORG to 0.8 to 1.2 mm.

(5) Adjusting the button positioning detection switch (BUT)

Button positioning detection switch ① (hereinafter called BUT) which incorporates a proximity sensor (GXL-8F) is a sensor to detect whether a button exists within positioner ② when actuating the positioner (triple pawl).

(It turns OFF when a button exists in the positioner or turns ON when it does not detect any button there.)

Draw the iron core of positioning solenoid ③ when there is no button in positioner ②, and the triple pawl will be closed. In this state, loosen the fixing screw of triple pawl dog ④, and move triple pawl dog until BUT which has been in the OFF state turns ON. Then further move the triple pawl dog forward from the aforementioned position (Fig. a- ① on the page 24) by 1.5 mm (Fig. a- ② on the page 24), and tighten the fixing screw of the triple pawl dog.

Then, confirm that BUT turns OFF when the triple pawl clamps a $\phi 10$ mm button. Also confirm that BUT turns On when the triple pawl is closed after taking out the button from it.

Be sure to remember that adjustment (6) should be carried out whenever the aforementioned adjustments have been carried out.

(6) Adjusting the fine positioning completion switch (RFIN)

Fine positioning completion switch ⑤ (hereinafter called "RFIN") which incorporates a proximity sensor (GXL-8F) is the sensor to detect a button when the button is set on the carrier pin.

Place a $\phi 10$ mm button in triple pawl ②, draw the iron core of positioning solenoid ③ toward you to make the triple pawl clamp ② the periphery of the button. In this state, loosen fixing screw of fine positioning sensor dog ⑦, and move the RFIN to the position where the RFIN changes from its OFF state to ON state (Fig. b- ①). Then move back the RFIN from the aforementioned position by 1.5 mm (Fig. b- ②), and tighten the fixing screw. Then confirm first that the RFIN turns OFF when the triple pawl clamps a $\phi 10$ mm button. Remove the button from the triple pawl, and confirm that the RFIN turns ON when the triple pawl clamps the periphery of the lower section of the work attachment.

Note that adjustment (5) should have been completed before starting this adjustment.

(Caution) The RFIN functions to detect a button when the button is completely set on the carrier pin by turning itself ON/OFF in accordance with the difference between the outside diameter of the button and that of the work attachment and to open/close the shutter.

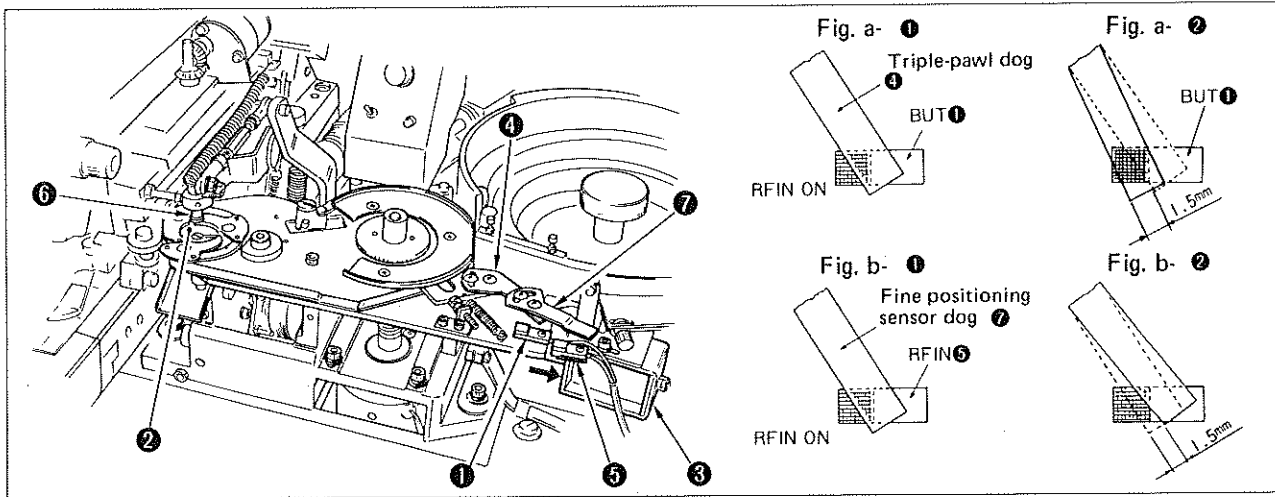

5. ADJUSTMENTS

1. Adjusting the parts feeder

(1) Operation of the control panel (2)

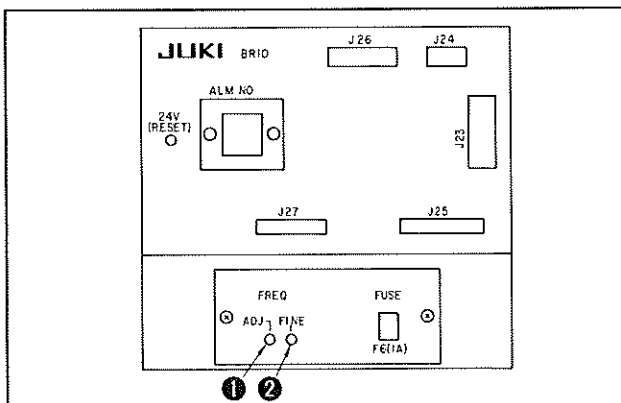

- 1) The parts feeder is energized by turning ON the power to the device.
- 2) Set the parts feeder adjusting variable resistor (Refer to page 17 "Parts feeder adjusting variable resistor" to its intermediate position.)
- 3) If the feeder does not vibrate adequately, turn sensitivity adjustment variable resistor ① until it reaches the position to allow the feeder to vibrate most. Then turn sensitivity adjustment variable resistor ② and make a fine adjustment so that vibration of the feeder is maximized.
- 4) Adjust the flow of buttons using the parts feeder adjusting variable resistor.

(Caution) Sensitivity adjusting variable resistor ② is very delicate. It is advisable to place buttons with flat bottom in the feeder bowl, and adjust the flow of buttons while checking the actual flow of the buttons. This will allow you to adjust the flow of buttons with ease.

(2) Adjusting the attachments in the feeder bowl

(2)-1 Guide plate

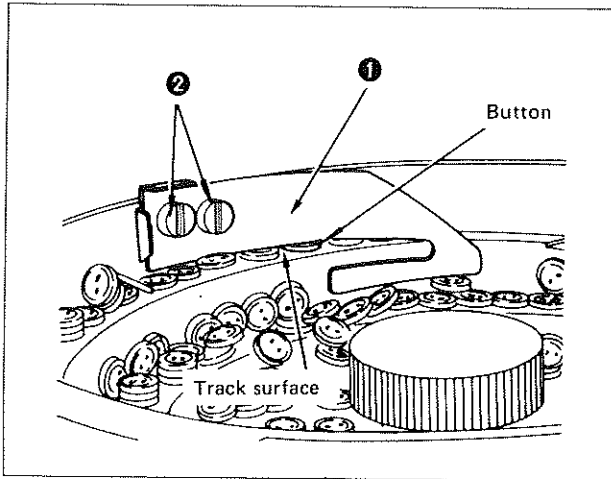

- 1) The appropriate clearance between the button top face and the guide plate ① is approximately 0.7 mm.
- 2) Loosen screws ②, and move guide plate ① up and down to adjust the clearance appropriately.

(2)-2 Separation plate

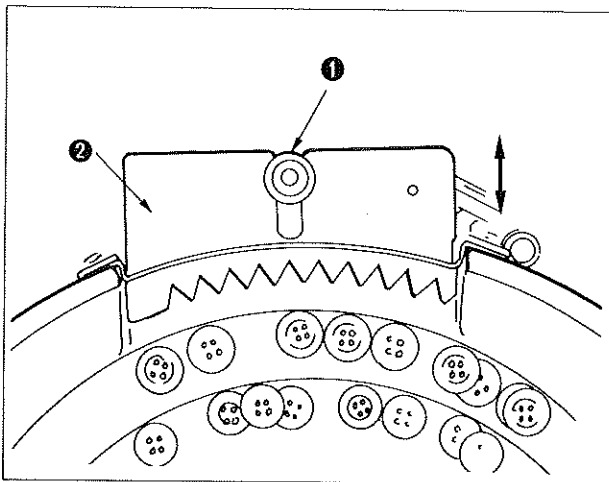

Buttons with their wrong side up are sorted from those with their right side up when they pass the selector plate. So only the buttons with their right side up are fed into the index unit. To adjust the selector plate, loosen bolt ①, and move selector plate ② back or forth until it is properly positioned. Then tighten bolt ①. The selector plate comes in three different sizes, large, medium and small. Select an appropriate one from among the three different types of selector plate in accordance with the size of buttons to be used.

(2)-3 In-line arrangement plate

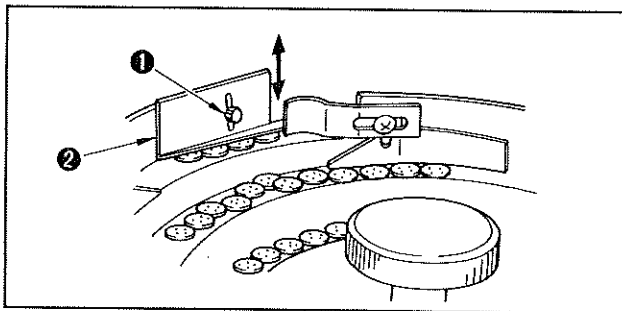

This plate prevents buttons which have passed the separation plate from piling up. The appropriate clearance between in-line arrangement plate ② and the top face of a button is approximately 0.7 mm.

Loosen bolt ①, and move the in-line arrangement plate ② up or down to adjust the clearance to the correct value.

(2)-4 Button guide

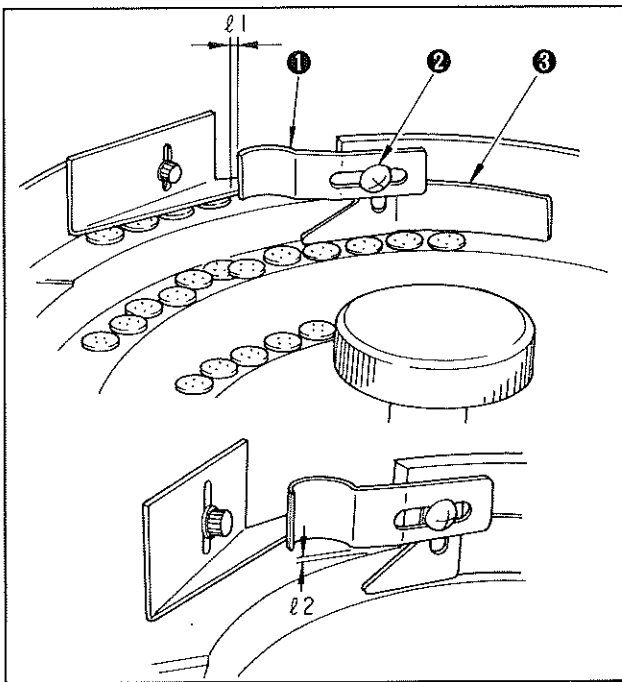

Appropriate clearance l_1 between the button guide ① and the button is approximately 3 to 4 mm. Loosen screw ②, and adjust the clearance to the correct value. A clearance which is larger than the value twice as thick as a button by approximately 0.7 mm should be provided between overflow prevention plate ③ and the button. Loosen screw ②, and adjust the clearance to the correct value. Appropriate clearance l_2 between lower surface of the button guide and the track surface of the feeder bowl is 0.3 to 0.5 mm.

(3) Adjusting the feed plate of the index unit

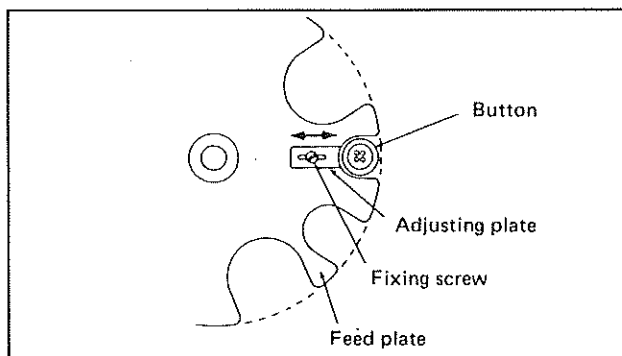
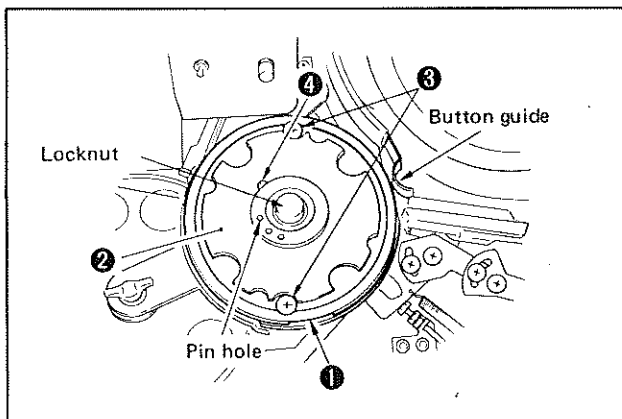

- 1) Confirm that the index unit is in its origin. Then loosen the locknut, and remove the button carrier. Loosen screws ③ and screw ④, and remove frame ① and the adjusting plate. Select one hole from among three holes with different diameters ($\phi 18$, $\phi 16$ and $\phi 12$) in the feed plate, and finely adjust the hole selected to the buttons to be used using the button adjuster. Adjust so that the periphery of the button is flush with the periphery of the feed plate.

Adjust the clearance into which the button is placed using the adjusting plate. Adjust the clearance to allow only one button to go through it. Once the feed plate is correctly positioned, fix it by tightening the screw.

Close the other holes using frame ①, and fix the frame using screws ③.

Install the feed plate which has been properly adjusted on the feeder. At this time, be careful to set the feed plate so that the button hole in it to be used meets the outlet of the feeder bowl.

Then, tighten the locknut.

(Caution) Tighten the screw with care since the screw is likely to break.

6. REPLACING THE COMPONENTS AND POSITIONING THEM

(1) Replacing the button carrier and positioning it

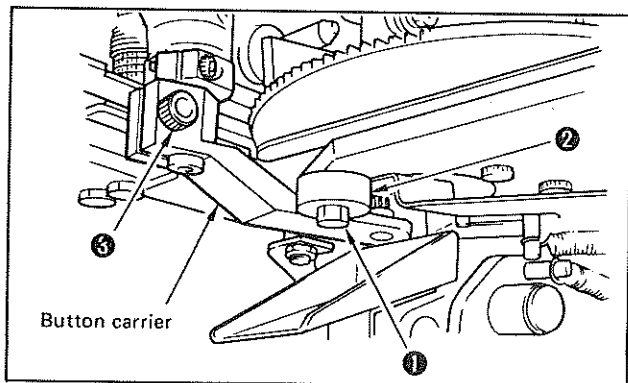

To replace the button carrier, loosen screw (3), then remove the button carrier. Replace the button carrier with one with a proper center-to-center distance, and fit the button carrier with a proper center-to-center distance to the eccentric cam, and simultaneously make the top face of the carrier come in contact with the nut. Now fix the carrier by screw (3).

(Caution) The above-stated positioning procedure should be carried out with the sewing machine set to the origin.

(2) Replacing the work attachment

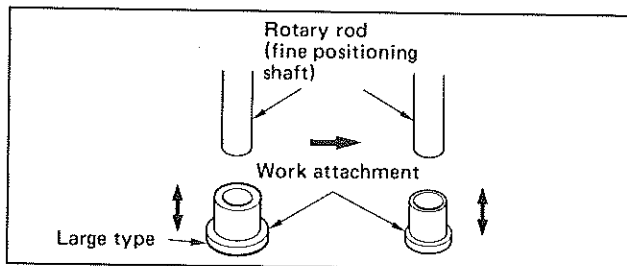

Remove the work attachment currently attached on the sewing machine from the rotary rod. Then attach the work attachment of another type on the machine. At this time, be sure to confirm that the work attachment securely fits in position.

This should be confirmed in the case of replacing any other components in the normal operation of the sewing machine.

(3) Replacing the feed plate and positioning it

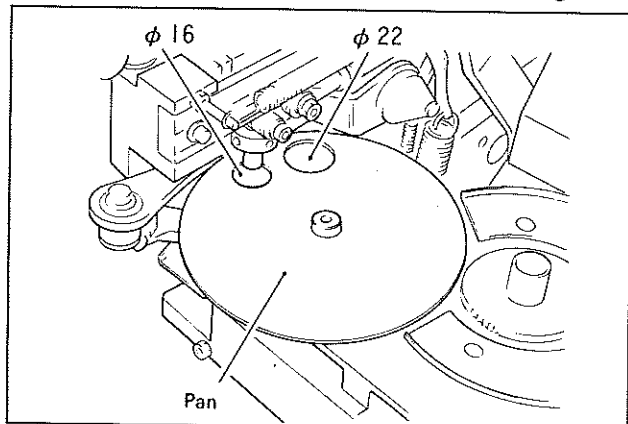

* A $\phi 22$ feed plate is also applicable by turning the pan over.

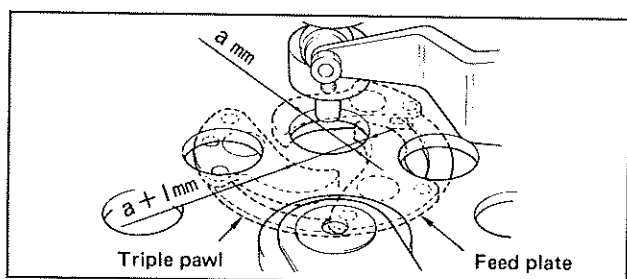
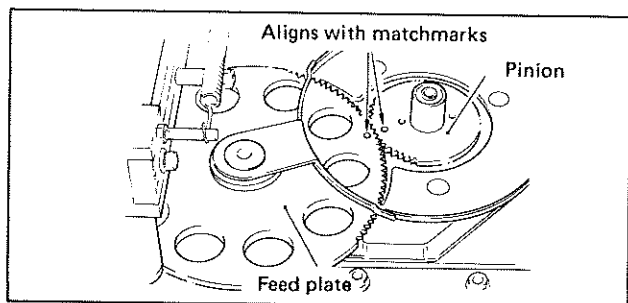

1) Pan

Use the feed plate of $\phi 16$ mm (standard) when sewing buttons of which outside diameter is $\phi 10$ mm to $\phi 15$ mm. If the outside diameter of the button is $\phi 16$ mm to $\phi 18$ mm, use the feed plate of $\phi 22$ mm (optional). At this time, it is necessary to adjust the pan located under the feed plate to the diameter of the hole in the feed plate. The pan is provided with two holes, one is $\phi 16$ mm hole and the other is $\phi 22$ mm hole. When using the feed plate of $\phi 16$ mm, attach the pan so that its $\phi 16$ mm hole comes this side with respect to the rotational direction of the feed plate. On the other hand, if using the feed plate of $\phi 22$ mm, attach the pan so that its $\phi 22$ mm hole comes this side with respect to the rotational direction of the feed plate.

- 2) To adjust the position of the feed plate, confirm first that the pinion is in its origin and attach the feed plate at the position where the matchmark (countersinking) on the pinion aligns with the matchmark on the feed plate. At this time, align the hole in the pan with the hole in the feed plate on the triple pawl.

- 3) Adjust the initial diameter of the triple-pawl taking the value which is obtained by adding 1 mm to the diameter of the button hole in the feed plate used as reference.

Make the adjustment using the positioning stopper bolt.

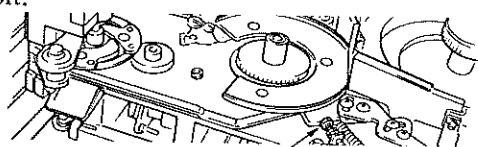

Positioning stopper bolt

7. OPTIONAL PARTS

1. Work attachment with a bottom of which diameter is larger than the standard type the standard type one is also available (part No. 16557704). Use this attachment for buttons with a larger diameter which cannot be smoothly turned by using the standard work attachment.
2. When using shell buttons, the edge of the buttons may break when triple pawl forcibly closes since the shape of the shell buttons are not uniform. When using small round-bottom buttons of $\phi 10$ or so, they may not be securely placed on the work attachment and may be snapped out of position when the triple-pawl closes since the pawl cannot securely hold the round-bottom buttons.

To prevent the above-stated troubles, use the smaller button hole in the feed plate asm. (part No. 18200956) (dia. 13.5 mm and the smaller hole in the receiving plate (small) (18201103).

Replace and adjust the feed plate following the procedure same as that taken when replacing and positioning the feed plate (Refer to page 27 "6-(3) Replacing the feed plate and positioning it."). For buttons of $\phi 16$ to $\phi 18$, use the feed plate $\phi 22$ asm. (part No. 16568651).

3. Button carrier

In addition to the two standard types of button carrier, 26 different types of button carrier are available in accordance with the number of holes in a button, the diameter of the holes in a button and the interval between the holes in a button. If either of the standard carriers does not match the button to be sewn, select an appropriate one from among the optional button carriers.

4. When sewing small buttons of which inside diameter is approximately $\phi 10$ mm, use the separation plate of the extra small size (18255153) if the right-sided buttons are not discriminated from the wrong-sided buttons-with accuracy.

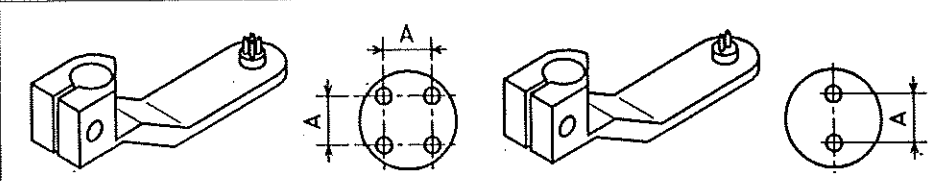

Code	Part No.	Dimension A	Number of lines	Number of holes in a button	Specification
A	165-57902	2.6	1.0	4	Standard type
B	165-58009	3.2	1.2	2	
C	165-87107	3.8	1.2	2	Special-order type
D	165-87206	3.1	1.0	4	
E	165-87305	2.0	1.0	2	
F	165-87404	2.2	1.0	2	
G	165-87503	2.4	1.0	2	
H	165-87602	2.6	1.0	2	
J	165-87701	2.8	1.0	2	
K	165-87800	3.0	1.0	2	
L	165-87909	2.4	1.2	2	
M	165-88006	2.6	1.2	2	
N	165-88105	2.8	1.2	2	
P	165-88204	3.0	1.2	2	
Q	165-90507	2.0	1.0	4	
R	165-90606	2.2	1.0	4	
S	165-88501	2.4	1.0	4	
T	165-88600	2.4	1.2	4	
U	165-88709	2.6	1.2	4	
V	165-88808	2.8	1.2	4	
W	165-88907	3.0	1.2	4	
X	165-89004	3.1	1.2	4	
*Y	165-89103	2.6	1.2	(Spacer) 4	
Z	165-89202	3.1	1.4	4	
E1	165-89707	4.0	1.2	4	
F1	165-89806	3.0	1.5	4	
G1	165-89905	3.2	Taper	4	
H1	165-90705	3.6	1.2	4	

The standard spacing amount is 2 mm. The parts to be spaced are as follows:
 B2555-372-ROJ Button clamp (left)
 B2557-372-ROJ Button clamp (right)

8. HOW TO REPLACE THE BUTTONS (on the button feeder side)

○ The following briefly describes the important points to be checked when replacing the buttons.

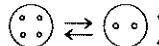
(1) When the number of holes in a button changes ()

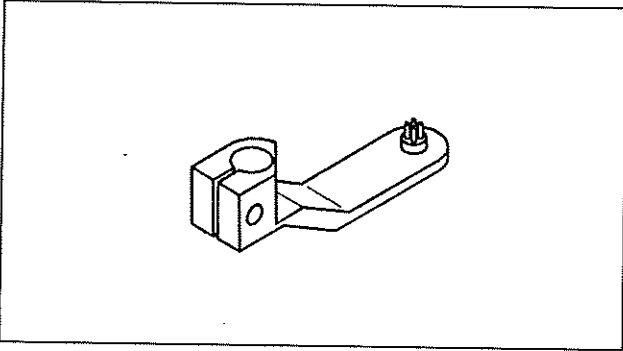

- 1) The button carrier needs to be changed accordingly.
- 2) Select the button feeder suited to the button to be used in terms of the number of holes in a button and the distance between the center of holes in a button (hole-to-hole distance). (See page 28)

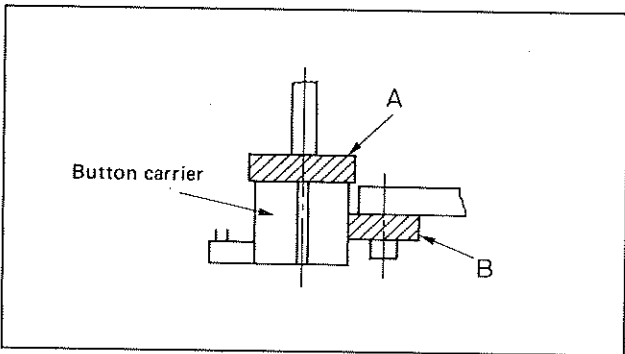

- 1) The button carrier can be replaced with another one at the origin of the button carrier (the position where a button is placed in the button carrier).
- 2) Set the button carrier in plate while pressing it against stoppers A and B.

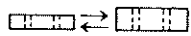
(2) When the button thickness changes ()

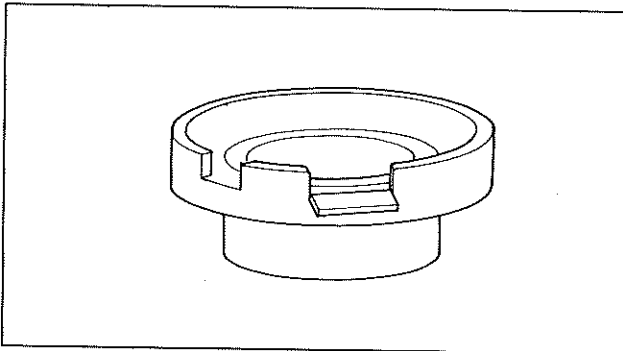

- 1) Adjust so that buttons in the feeder bowl smoothly flow and the separation plate discriminates the right-sided buttons from the wrong-sided buttons without fail. (See page 25. "5-(2) Adjusting the attachments in the feeder bowl")

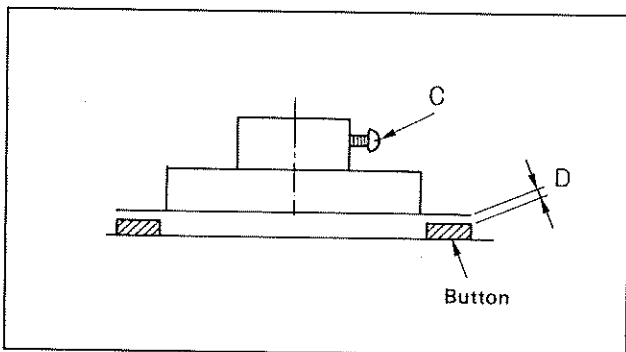

- 2) Adjust the feed plate (a component made of plastic) in accordance with the thickness of the button to be used. To adjust the feed plate in the vertical direction, loosen screw C and set dimension D approximately to 0.7 mm.

(3) When changing the outside diameter of button ($\odot \rightleftharpoons \odot$)

- Adjust so that buttons in the feeder bowl smoothly flow and the separation plate discriminates the right-sided buttons from the wrong-sided buttons without fail.
- Adjust the feed plate (a component made of plastic) in the radial direction.

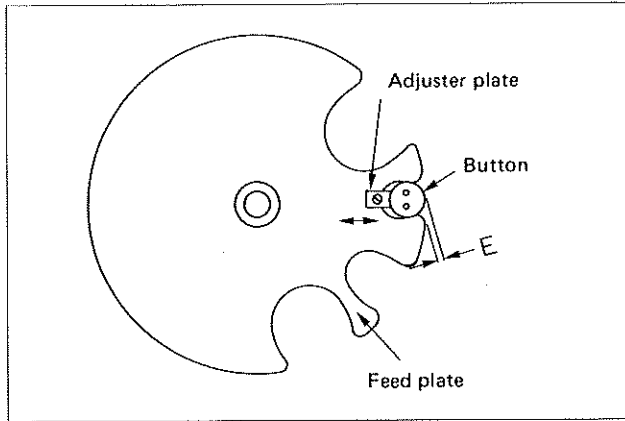

- The feed plate has three holes with different diameters, i.e., large, medium and small.

- 1) The small hole is used for buttons of which outside diameter is $\phi 10$ to $\phi 11.5$ mm. The medium hole is used for buttons of which outside diameter is $\phi 13$ to $\phi 15$ mm.
- 2) Adjust the adjuster plate so that E becomes 0 when setting a button in the hole.
- 3) When changing over the hole to be used between the small one and the medium one, move the frame of the feed plate (\odot) accordingly to allow the button to be used fits in the hole selected.

(Caution) Be sure not to excessively tighten the screw in the feed plate (made of plastic).

[Example]

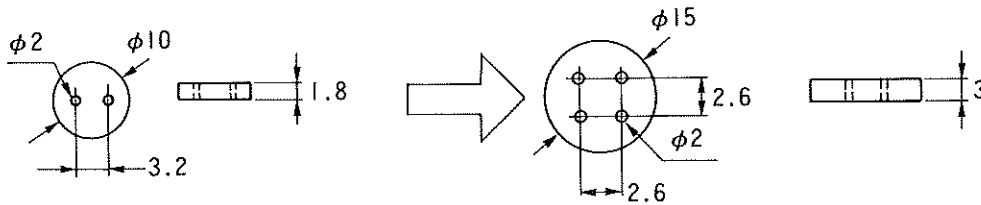

How to adapt the button feeder components to the following button changing

- A. First, the button carrier needs to be changed since the distance between the center of holes ($3.2 \rightarrow 2.6$) in a button and the number of holes in a button ($2 \rightarrow 4$) of the two buttons are different.
 - B. The feed plate needs to be adjusted in the vertical direction since the button thickness changes from 1.8 to 3.
 - C. The hole of the feed plate to be used needs to be changed from the small hole to the medium hole, and the adjuster plate should be adjusted since the outside diameter of button changes from $\phi 10$ to $\phi 15$ mm.
- * Whenever changing the button to be used, check first whether or not the aforementioned changes in the components or adjustments of them are necessary. Then change or adjust the components, if necessary.

JUKI

JUKI CORPORATION

HEAD OFFICE

8-2-1 KOKURYO-CHO,
CHOFU-CITY, TOKYO 182, JAPAN

BUSINESS OFFICE

1-23-3 KABUKI-CHO
SHINJUKU-KU, TOKYO 160, JAPAN

PHONE : 03(3205)1188, 1189, 1190

FAX : 03(3203)8260, (3205)9131

TELEX : J22967, 232-2301

To order or for further information, please contact :

Please do not hesitate to contact our distributors or agents in your area for further information when necessary.
* The description covered in this instruction manual is subject to change for improvement of the commodity without notice.
* This instruction manual is edited and printed in accordance with the product specifications as of June, 1992.