

**JUKI**

High Speed 1-Needle Lockstitch Straight Buttonholing  
Industrial Sewing Machine

**LBH-791NS·LBH-792NS·LBH-793NS·LBH-794NS**

(General-use motor)

**LBH-791NS-1·LBH-792NS-1·LBH-793NS-1·LBH-794NS-1**

(Electronic-stop motor)

# **INSTRUCTION MANUAL**

---

No. 00  
29125606



## CONTENTS

<b>INTRODUCTION</b> .....	1
<b>OPERATION PRECAUTIONS</b> .....	1
<b>SPECIFICATIONS</b> .....	1
1. Motor pulley and V-belt (general-use motor) .....	2
2. Motor pulley and V-belt (electronic-stop motor) .....	2
3. Installing the sewing machine head .....	3
4. Connecting the cables (electronic-stop motor) .....	4
5. Installing the thread stand .....	6
6. Installing the sewing machine head support rod .....	6
7. Installing the V-belt (general-use motor) .....	6
8. Installing the V-belt (electronic-stop motor) .....	7
9. Remove and installing the belt cover .....	7
10. Installing the side-face belt cover .....	7
11. Lubrication .....	8
12. Attaching the needle .....	9
13. Removing and installing the bobbin case .....	9
14. Winding the bobbin thread .....	9
15. Installing the bobbin .....	9
16. Threading the machine head .....	10
17. Running the sewing machine at low speed and the emergency stop (general-use motor) .....	10
18. Running the sewing machine at low-speed and the emergency stop (electronic-stop motor) .....	11
19. Manual feed handle .....	11
20. Stop the cloth cutting knife from working .....	11
21. Seam specifications .....	11
22. Thread tension .....	12
23. Adjusting the overedging length (material feed amount) .....	14
24. Replacing the cloth cutting knife .....	14
25. Adjusting the overedging width (stitch width and bartacking width) and the overedging standard position .....	15
26. Changing the number of stitches .....	16
27. Adjusting the pressing pressure of the work clamp check .....	17
28. Needle-to-hook relationship .....	17
29. Adjusting the tension of the timing belt .....	18
30. Adjusting the needle thread cutter scissors .....	18
31. Adjusting the bobbin thread cutter scissors .....	19
32. Adjusting the dropping timing of the cloth cutting knife .....	19
33. Adjusting the speed reduction mechanism (general-use motor) .....	20
34. Speed control (electronic-stop motor) .....	20
35. Soft start (electronic-stop motor) .....	21



36. Adjusting the needle stopping position (electronic-stop motor) -----	21
37. Adjusting the stop-motion solenoid (electronic-stop motor) -----	21
38. Troubleshooting (when sewing) -----	22
39. Troubleshooting (during an operation other than sewing) -----	23



## INTRODUCTION

Congratulations on your purchase of a JUKI sewing machine.

Please read this Instruction Manual carefully before using the unit in order to get the most out of it and to enjoy using it for a long time.

## OPERATION PRECAUTIONS

1. The normal rotating direction of the sewing machine is counterclockwise, as observed from the pulley side. Be sure not to let it rotate in a clockwise direction.
2. Never operate the machine unless the sewing machine head base has been properly lubricated.
3. Be sure to remove the bobbin case and needle thread from the machine when doing trial sewing.
4. Be sure to remove any dust from the hook or bobbin thread cutting knife section at the end of the day, and check the amount of oil remaining.
5. Be sure to return the activating pedal to the home position after the machine has started to run. If the pedal is held depressed, the sewing machine may double the seam or cause a stop-motion during sewing at high speed.

## SPECIFICATIONS

	LBH-791NS LBH-791NS-1	LBH-792NS LBH-792NS-1	LBH-793NS LBH-793NS-1	LBH-794NS LBH-794NS-1
Application	Sewing buttonholes in general garments made of fabric, or knitted fabric			
Sewing speed	Max.: 4,000 s.p.m. Normal: 3,300 s.p.m.			
Buttonhole length	6.35~19.05 mm	6.35~25.4 mm	6.35~31.8 mm	12.7~38.1 mm
Bartacking width	2~4 mm	2~5 mm		
Needles	DP X 5 #11J~#14J			
Height of the work clamp check	12 mm (max. 14 mm)			
Lubricating oil	JUKI New Defrix Oil No.1			



## 1. Motor pulley and V-belt (general-use motor)

Rotating speed	Frequency	Part number of the motor pulley	High-speed V-belt	Low-speed V-belt
4,000 s.p.m.	50Hz	13769104	62"	54"
	60Hz	13769500	60"	53"
3,600 s.p.m.	50Hz	13769203	60"	53"
	60Hz	13769609	58"	53"
3,300 s.p.m.	50Hz	13769302	60"	54"
	60Hz	13769708	58"	53"
3,000 s.p.m.	50Hz	13769401	59"	54"
	60Hz	13769807	57"	53"

(Part number of the V-belt: MTJ-VM00 □□00, □□: V-belt length)

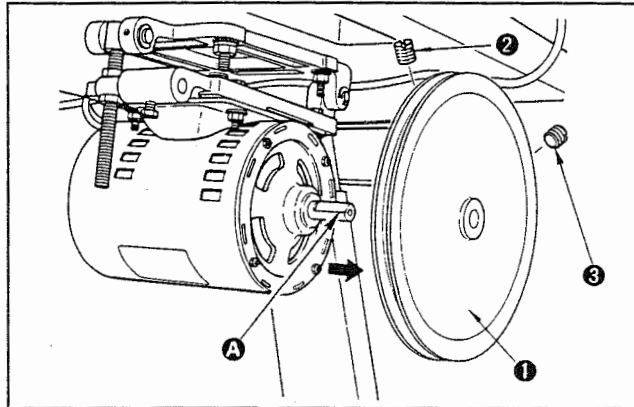

- 1) Use a 4-pole 300W motor for both single phase and 3-phase.
- 2) Use an M type V-belt.
- 3) The relationship between the motor pulley length of the V-belt and the rotating speed of the sewing machine is shown in the table.

**(Caution)** When a 250W motor is used, be sure to run the machine at 3,000 s.p.m. or less. And when the machine is operated on 100V, be sure to run the machine at 3,300 s.p.m. or less.

- 4) Installing the motor pulley  
Fit motor pulley ① on to the motor shaft that flat section ④ of the motor shaft is aligned with setscrew No. 1 ②. Then securely tighten setscrews ② and ③.

**(Note)** Optional parts [Motor pulley c (13772553), three attachment screws SK3452000SE, and three attachment washers WP0501016SC] are available to enable the motor pulley and V-belt to be installed without them coming in contact with each other.

## 2. Motor pulley and V-belt (electronic-stop motor)

Rotating speed	Frequency	Part number of the motor pulley	Outside diameter	V-belt length
4,000 s.p.m.	50Hz	MTSP00950B0	100	56"
	60Hz	MTSP00800B0	85	
3,600 s.p.m.	50Hz	MTSP00850B0	90	56
	60Hz	MTSP00700B0	75	55
3,300 s.p.m.	50Hz	MTSP00800B0	85	56
	60Hz	MTSP00650B0	70	55
3,000 s.p.m.	50Hz	MTSP00750B0	80	56
	60Hz	MTSP00600B0	65	55

- 1) Use an M type V-belt.
- 2) The relationship between the motor pulley length of the V-belt and the rotating speed of the sewing machine is shown in the table.



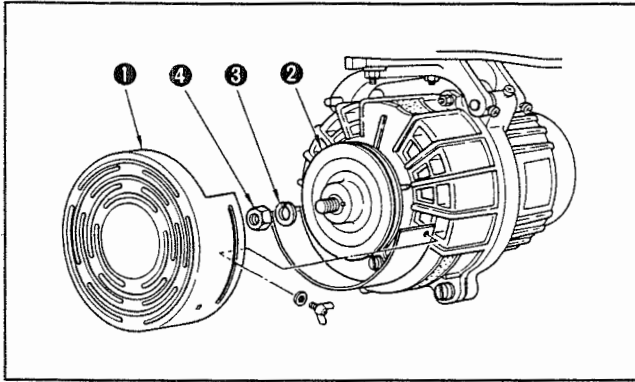

- 3) **Installing the motor pulley**  
Remove pulley cover ① and fit motor pulley ② aligning the key groove with the motor shaft.

Then attach spring washer ③ and tighten nut ④ using a wrench or something similar.

When detaching motor pulley ②, remove the pulley cover and follow the installation procedure in the reverse order.

The gear puller (part number J1065000000) which is separately available will facilitate the motor pulley detachment.

**(Cautions)**

1. The hole in the motor pulley is tapered, so the pulleys already on the market cannot be used.
2. The effective diameter is 5 mm smaller than the outside diameter.
3. When detaching the motor pulley, do not hit the pulley excessively with a hammer. Doing so may damage the pulley.

**3. Installing the sewing machine head**

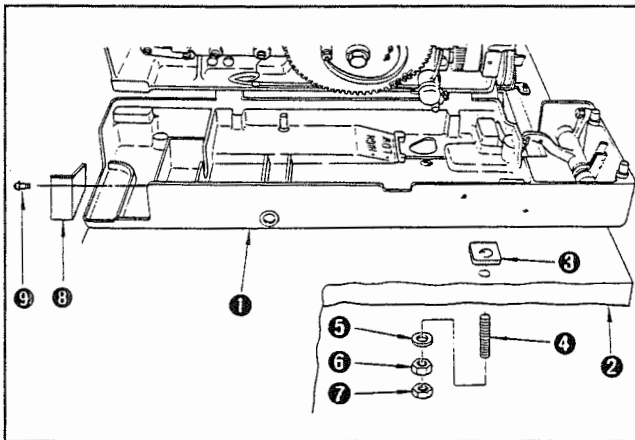

- 1) Insert felt pad ③ between sewing machine head base ① and table ②. Screw in fixing bolt ④, fit a washer ⑤, and securely tighten two nuts ⑥ and ⑦ so that the felt pad ③ becomes dented by 5 mm. (There are four different points requiring this procedure.) Install hook cover ⑧ with setscrew ⑨.

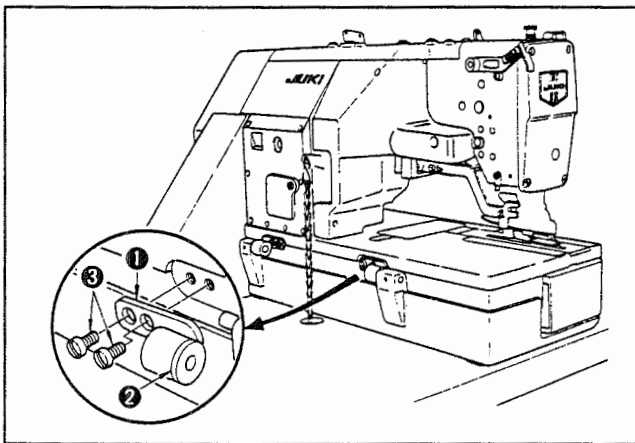

- 2) Into each of the two different points on the sewing machine head, insert hinge plate ① and cushion ②, then securely fit the hinge plate with two setscrews ③.



#### 4. Connecting the cables (electronic-stop motor)

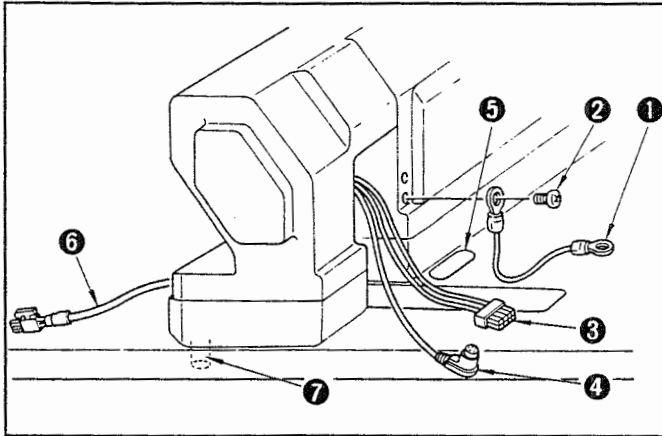

- 1) Attach earth cable ① for the machine head, using screw ②, to the sewing machine.
- 2) Pass machine head switch cable ③, synchronizer cable ④ and machine head earth cable ① through hole ⑤ in the table.
- 3) Pass stop-motion magnet cable ⑥ through hole ⑦ in the table.

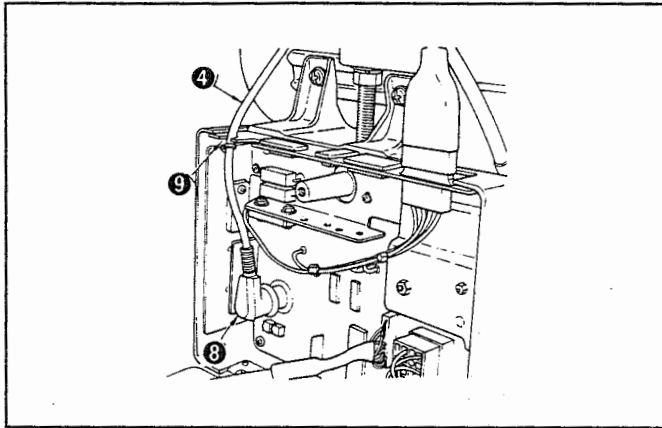

- 4) Connect synchronizer cable ④ to connector ⑧ in control box MC-50A, and then fit cable bush ⑨ into the hollowed section of the control box.

**(Caution)** If the synchronizer cable is not securely connected, the sewing machine might start running at high speed soon after the power supply has been turned on.

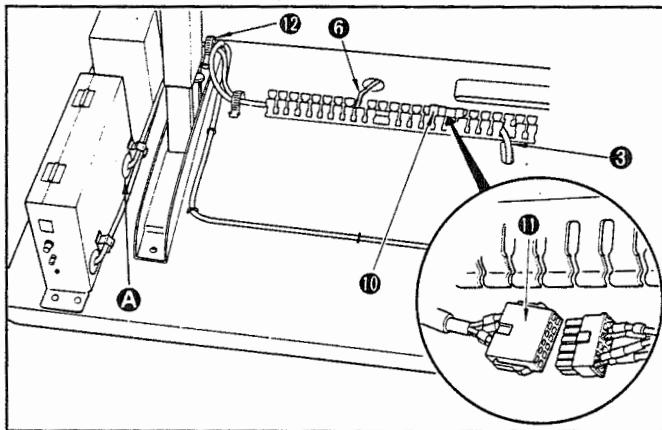

- 5) Connect machine head switch cable ③ to connector ⑪ in duct ⑩ mounted under the table.

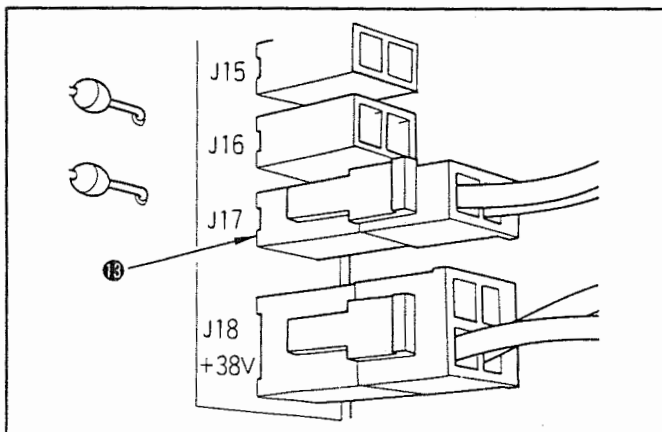

- 6) Pass stop-motion magnet cable ⑥ downward out from the hole in the bottom face of the sewing machine head base. Then pass it along the duct, through cable clamp ⑫, and then insert it into hole ① in the control box. Finally, connect the cable to connector (J17) ⑬ in the control box.



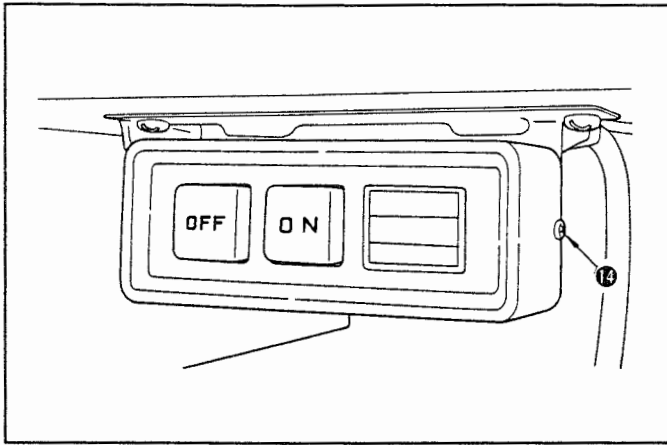

7) Remove screw 14 from the switch box, then remove the cover.

**(Caution)** Before removing the cover, be sure to confirm that the power plug has been removed.

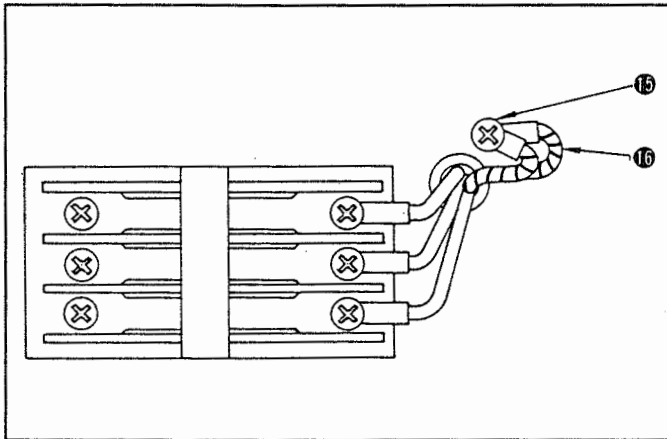

8) Remove screw 15 of the earth cable from the switch box.

Then fix machine head earth cable (yellow/green) 16 to the switch box using the screw.

9) Attach the switch cover again to the switch box.



### 5. Installing the thread stand

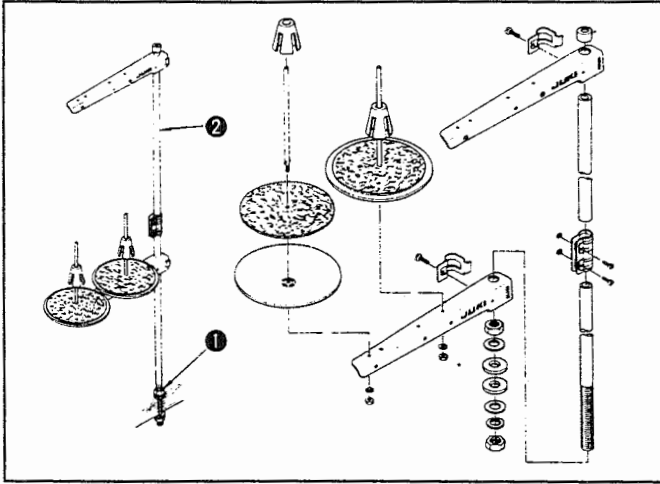

- 1) Assemble the thread stand unit, as shown in the figure and insert it into the hole in the machine table.
- 2) Tighten locknut **1** to fix the thread stand.
- 3) For ceiling wiring, pass the power cable through spool rest rod **2**.

### 6. Installing the sewing machine head support rod

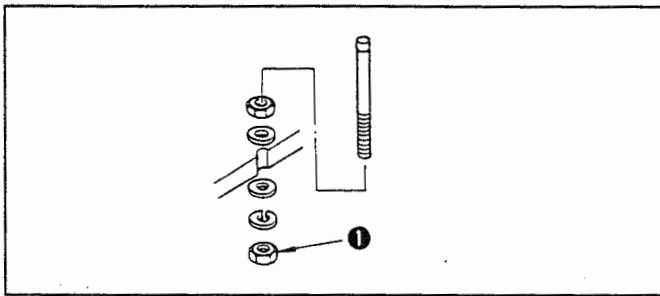

Insert the sewing machine head support rod into the hole in the machine table, as shown in the figure. Then tighten nut **1** to fix the support rod.

### 7. Installing the V-belt (general-use motor)

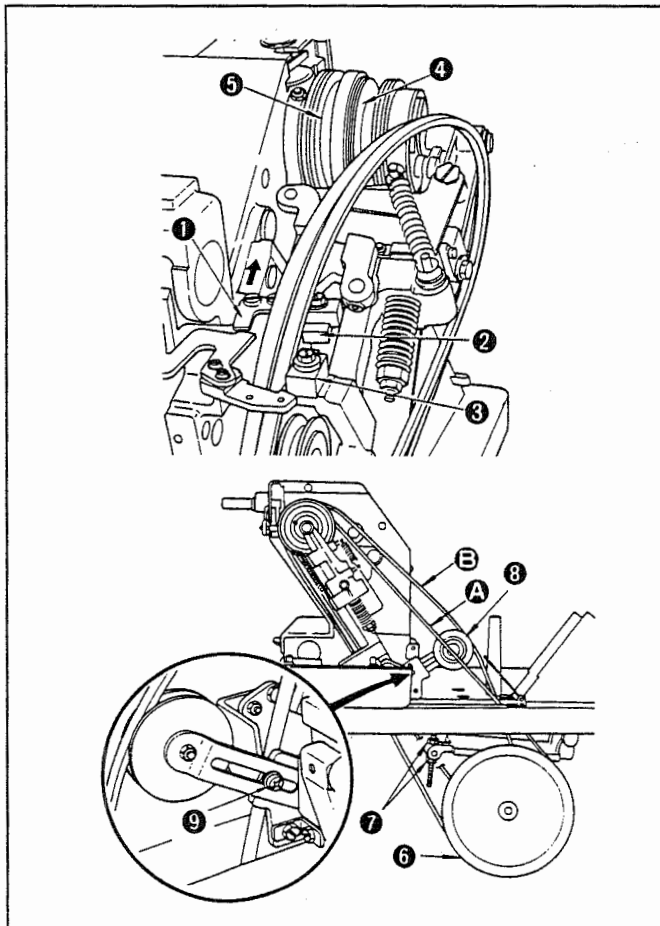

- 1) Tilt the sewing machine, and lift hook take-off lever **1** in the direction of the arrow to pass both the high-speed belt and the low-speed belt between hook B **2** and hook A **3**.
- 2) Hang the high-speed V-belt (longer one) on either high-speed pulley **4** or motor pulley **6**, whichever has the larger diameter. Then adjust the belt tension with adjusting nut **7** so that there is approximately 20 mm of slack when the belt is pushed lightly in the direction of arrow **A**. Now securely tighten the adjusting nut. If the belt is tightened excessively, an irregular noise or heat may be generated.
- 3) Hang the low-speed V-belt (shorter one) on either low-speed pulley **5** or motor pulley **6**, whichever has the smaller diameter, also hanging it on tension pulley **8** in the middle. Then adjust the belt tension with adjusting screw **9** so that there is approximately 10 mm of slack when the belt is pushed lightly in the direction of arrow **B**. Now securely tighten the adjusting screw.



### 8. Installing the V-belt (electronic-stop motor)

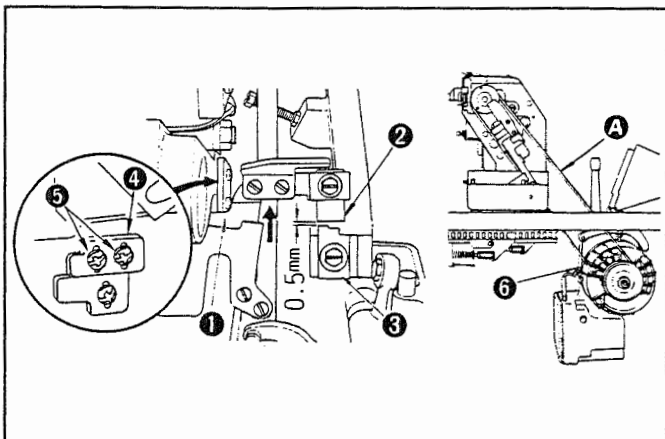

- 1) Tilt the sewing machine and remove screw 5 and stopper 4. Then lift hook take-off lever 1 in the direction of the arrow so that it passes both the high-speed belt and the low-speed belt between clearance formed by hook B 2 and hook A 3.
- 2) Then determine the position of stopper 4 so that a clearance of approximately 0.5 mm is obtained between hook B 2 and hook A 3. Now tighten the stopper with screw 5. Be sure to tighten the screw with hook take-off lever 1 set for high-speed operation.
- 3) Adjust the belt tension with adjusting nut 6 so that there is approximately 10 mm of slack when the belt is pushed lightly in direction A. Then securely tighten the adjusting nut.

### 9. Remove and installing the belt cover

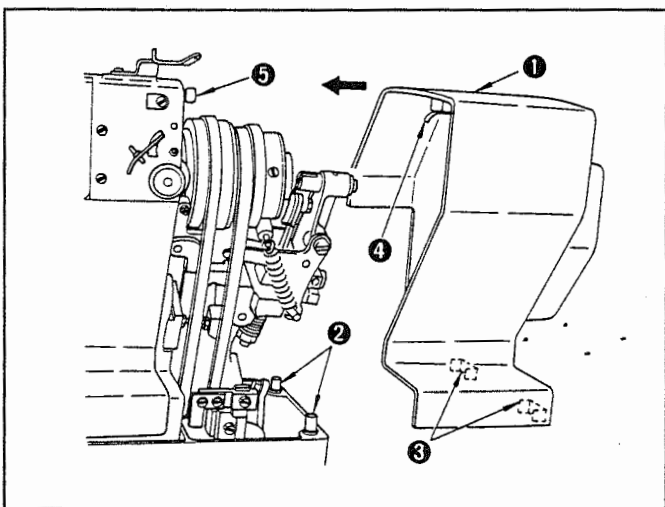

After inserting leaf spring 3 of belt cover 1 into guide pin 2, press the belt cover in the direction of the arrow in order to connect set pin 4 to pin 5. When removing the belt cover, pull out the belt cover in the opposite direction of the arrow.

### 10. Installing the side-face belt cover

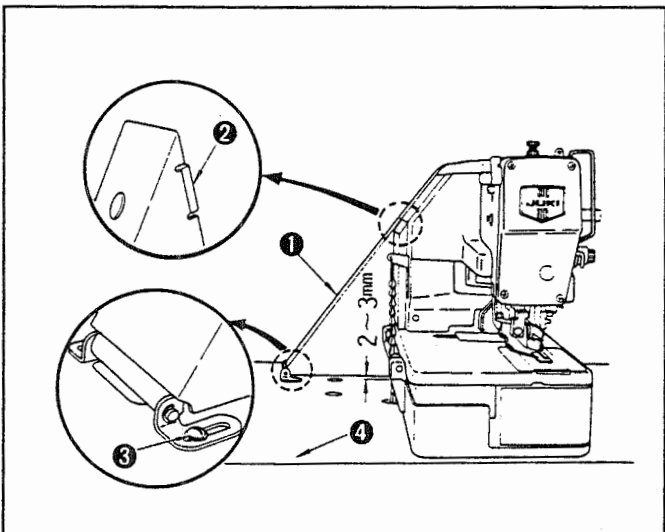

Attach the side-face belt cover with two wooden screws 3 so that side-face belt cover 1 and felt 2 on the top end lightly comes into contact with the sewing machine head, and so that a 2 ~ 3 mm clearance is obtained between machine table 4 and the side-face belt cover.



## 11. Lubrication

### (1) Before operation

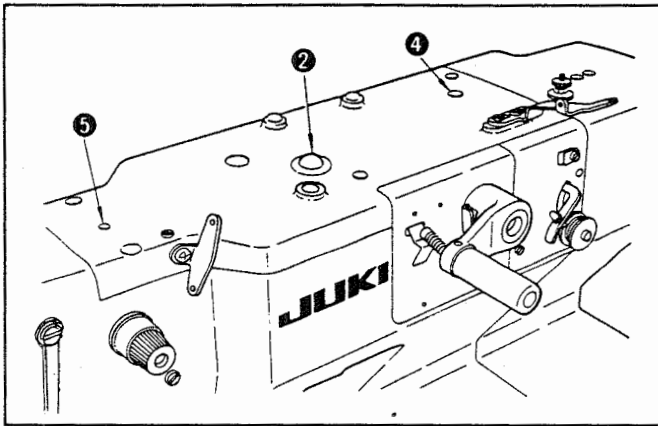
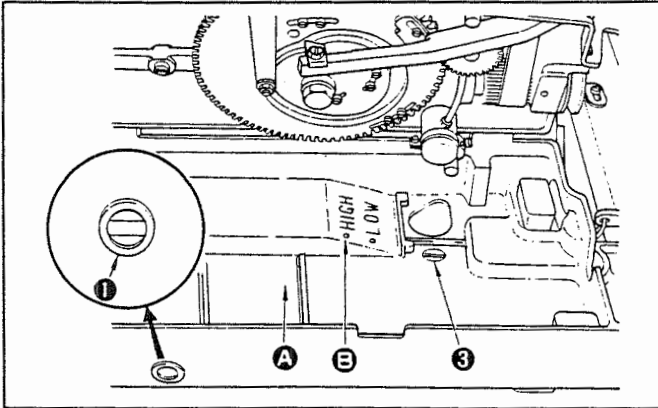

- 1) Fill head base **A** with JUKI New Defrix Oil No. 1 up to HIGH mark **B**.
- 2) When the machine is first installed, or when it is run after a long period of disuse, lubricate the machine from oil holes **4** and **5** using an oiler.
- 3) After lubrication, you can see the oil flowing into observation window **2** when the sewing machine is driven with normal lubrication.
- 4) When the oil level goes below the marker line on oil gauge **10**, refill with lubrication oil up to the proper level.
- When the oil becomes dirty, loosen drainage screw **3** to let the waste oil drain out, and refill with new oil.

### (2) Adjusting the hook lubrication

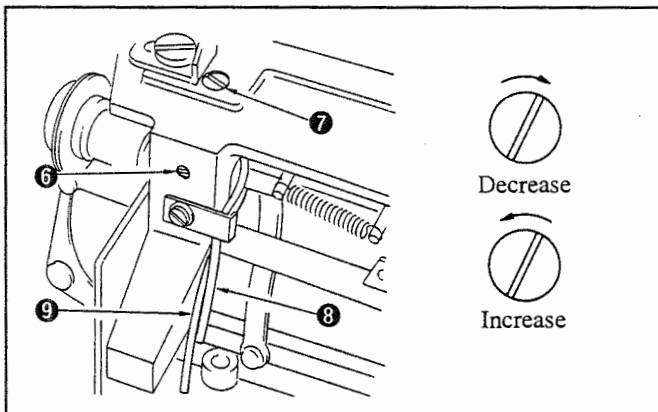

- 1) When adjusting the amount of oil in the hook, loosen screw **6** and turn adjusting screw **7**. After adjusted, tighten the screw **6**.
- 2) When the machine is first installed, or when it is run after a long period of disuse, lubricate felt **8** and oil wick **9** using the oiler.

### (3) Lubricating the stop-motion frame

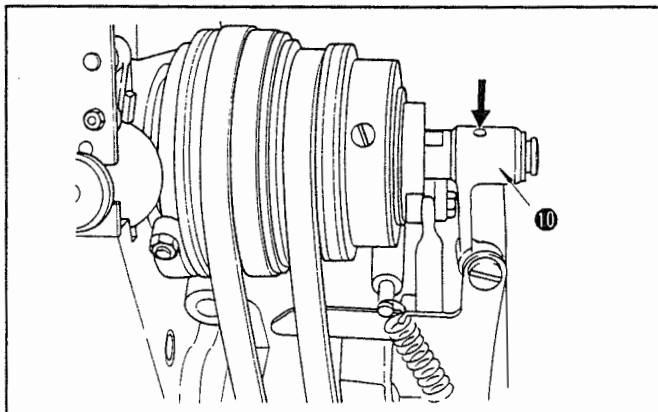

Once a week or once every two weeks, apply one or two drops of oil to stop-motion frame **10** of the general-use motor at the point indicated by the arrow.



## 12. Attaching the needle

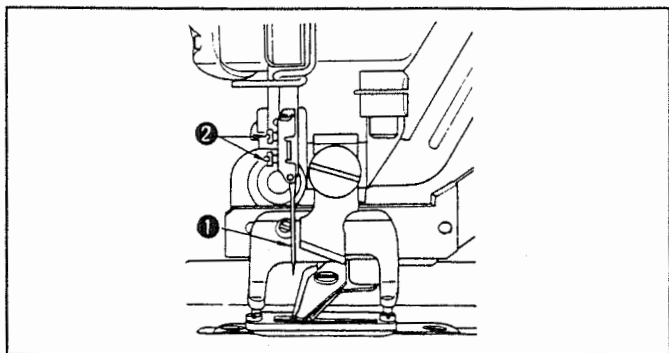

- Turn off the motor power.  
DP x 5J needle should be used.
- Loosen needle setscrew ②, and hold needle ① with its indented part facing toward you. Insert the needle ① into the needle clamping hole until it will go no further, and then securely tighten the needle setscrew ②.

## 13. Removing and installing the bobbin case

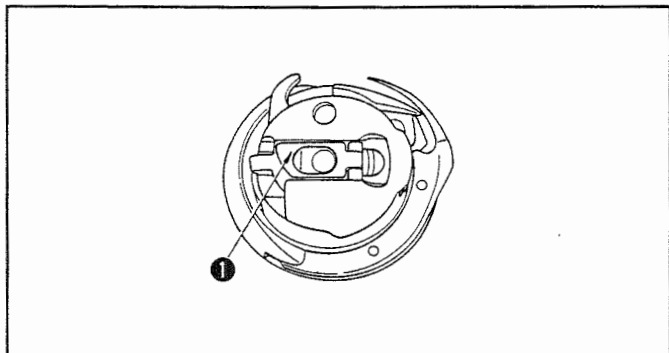

- 1) Remove the bobbin case with its latch ① raised. The bobbin will not slip off from the bobbin case as long as the latch is raised.
- 2) When installing the bobbin case in the hook, insert it into the hook driving shaft until it will go no further, and then release the latch.

## 14. Winding the bobbin thread

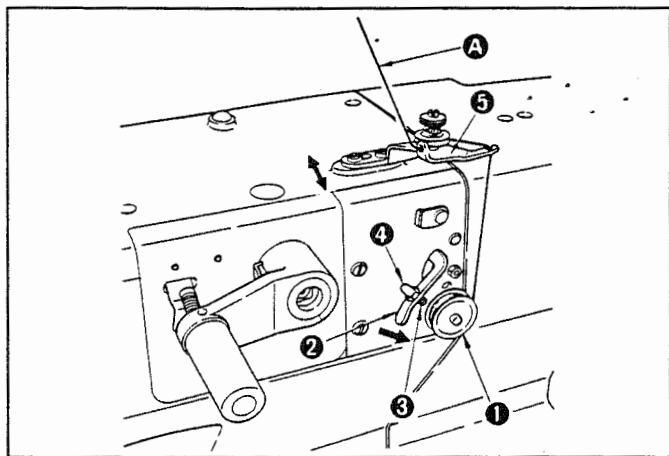

- 1) Fit bobbin ① onto the bobbin winder shaft.
- 2) Pass thread A in the order, as shown in the figure, and wind it around the bobbin several times.
- 3) Press bobbin thread guide ② in the direction of the arrow, and the bobbin thread will be automatically wound around the bobbin.
- 4) Loosen adjusting nut ④ to allow adjusting screw ③ to adjust the amount of bobbin thread to be wound. Adjust the thread amount so that it is approximately 80% of the bobbin outside diameter.
- 5) If the thread cannot be wound evenly, adjust the position of the bobbin thread by moving bobbin thread guide plate ⑤ in the direction of the arrow.

## 15. Installing the bobbin

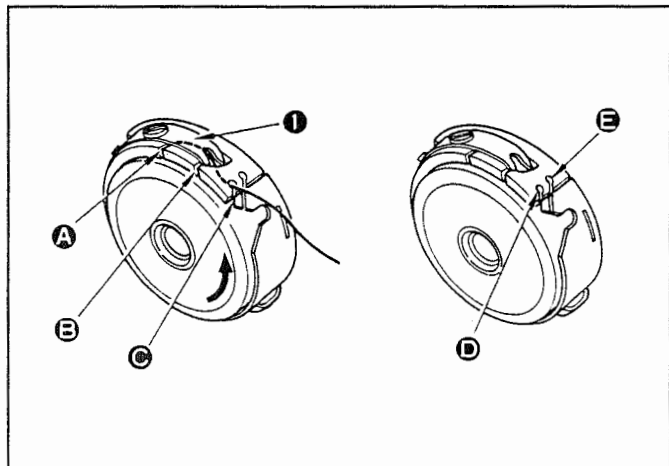

- 1) Install the bobbin in the bobbin case so that the thread winds counterclockwise.
- 2) Pass the thread through A, and allow it to go along with bobbin winder tension spring ①, and come out from slit B. Then pull the thread out from thread hole C.
- There are thread holes for both purl stitching D and whipped stitching E. For this type of stitching, thread the bobbin as shown in the figure.
- If you wish to use a thin tetron thread of which yarn count is #60 or finer, pass the thread through thread hole E even when performing purl stitching to produce uniform stitches.



## 16. Threading the machine head

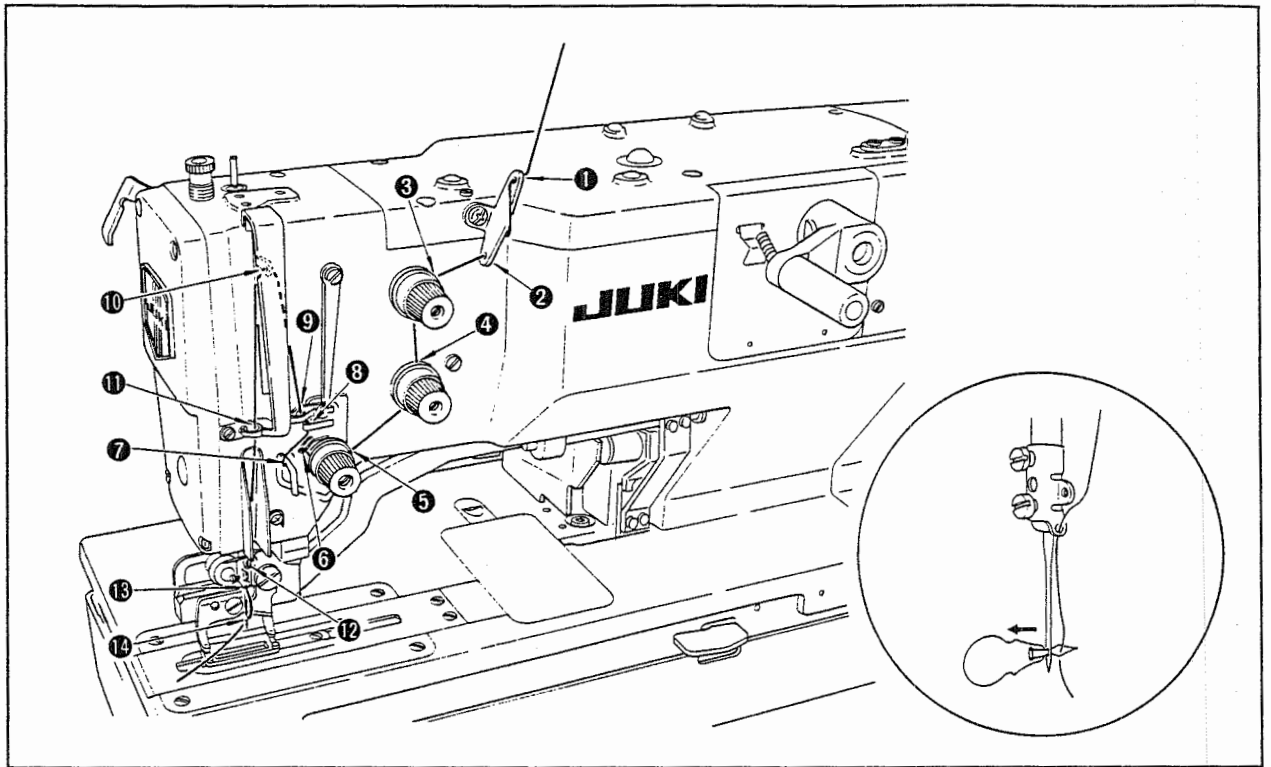

- 1) Thread the machine head as shown in the figure.
- 2) Threading the needle is made easier if you use the needle threader supplied with the unit.

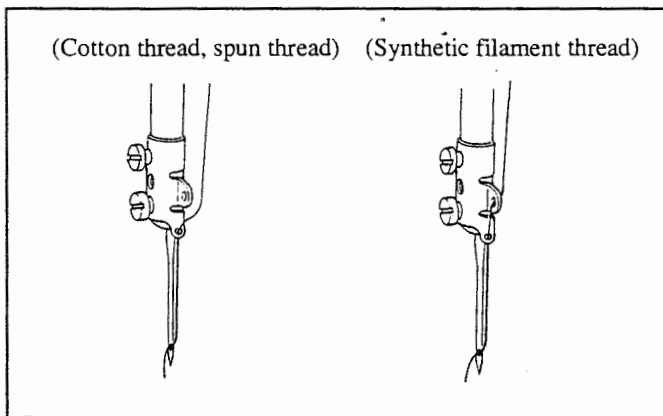

As shown in the figure, change the method of threading the thread path according to the type of thread to be used.

## 17. Running the sewing machine at low speed and the emergency stop (general-use motor)

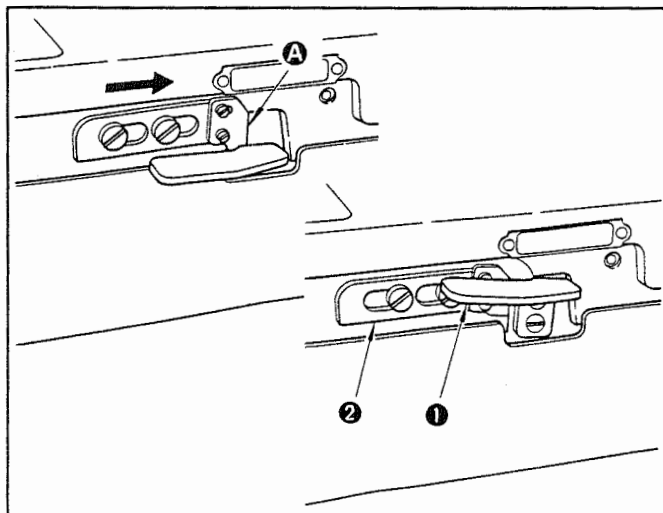

### (1) Running the sewing machine at low speed

- 1) Lower emergency stop lever ❶, and shift low-speed stopper ❷ in the direction of the arrow until it reaches position A.
- 2) Actuate the sewing machine and release the pedal to allow the machine to run at low speed.

### (2) Emergency stop

Bring by hand emergency stop lever ❶ to its lowest position. Then release it to its upper resting position, and the sewing machine will stop running.



## 18. Running the sewing machine at low speed and the emergency stop (electronic-stop motor)

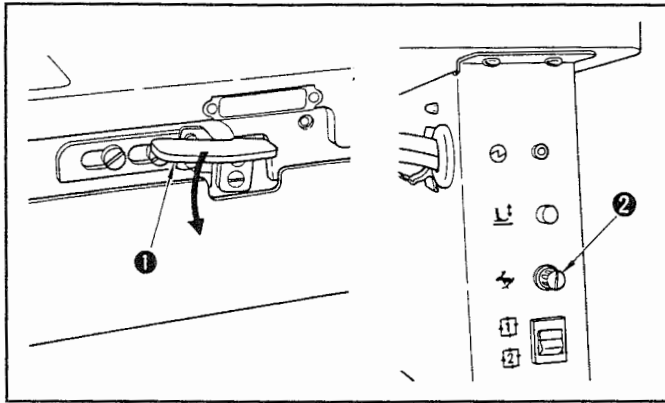

### (1) Running the sewing machine at low speed

Low-speed stopper ① allows the machine to run at low speed. Turn knob ② in the control box counterclockwise until it will go no further instead of using the low-speed stopper, and the machine will run at low speed (approximately 800 s.p.m.).

### (2) Emergency stop

Bring by hand emergency stop lever ① (as shown in the figure) to its lowest position, and the sewing machine will stop running.

## 19. Manual feed handle

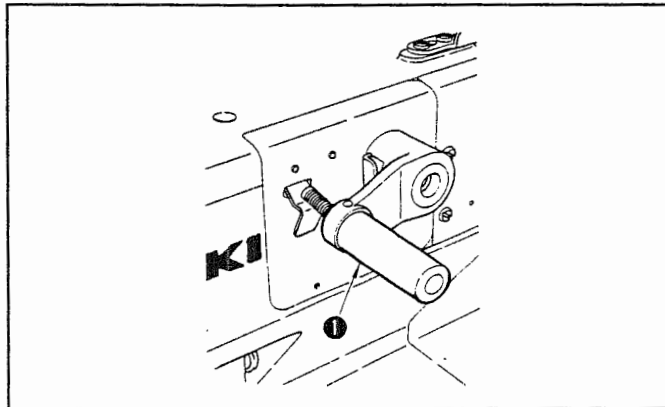

If you need to start sewing from the position where sewing has been interrupted due to an emergency stop or thread breakage, drive the cloth feed mechanism by hand while turning manual feed handle ①.

**(Caution)** Make sure that the needle has not penetrated the material before turning the manual handle.

**Be sure not to run the sewing machine with the manual handle removed.**

## 20. Stop the cloth cutting knife from working

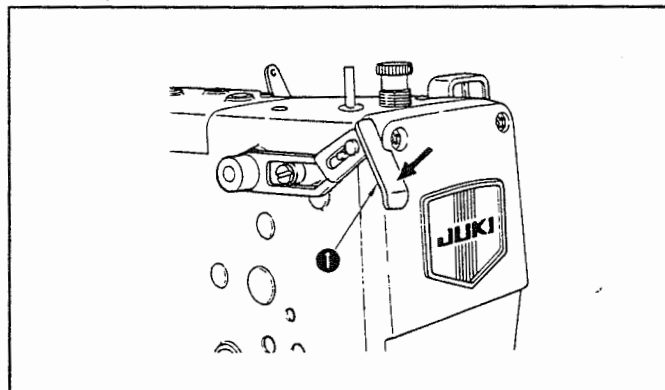

If the needle thread or bobbin thread breaks, or the cloth cutting knife does not need to drop, lightly press down knife stop lever ①.

The cloth cutting knife will now no longer drop to cut the material.

## 21. Seam specifications

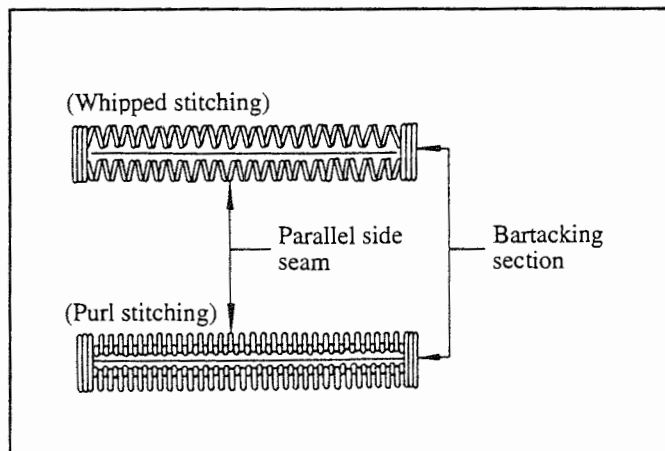

This sewing machine is capable of sewing buttonholes in two different types of seam: whipped stitching and purl stitching.

### (Whipped stitching)

Whipped stitching is similar to zigzag stitching whereby the seam is made so that the needle thread appears only on right side of the material, and the bobbin thread appears only on the wrong side of the material.

### (Purl stitching)

The seam in purl stitching is made when the needle thread goes on the surface of the seam with increased thread tension, and the bobbin thread tangles from the right and left to form a parallel side seam.



## 22. Thread tension

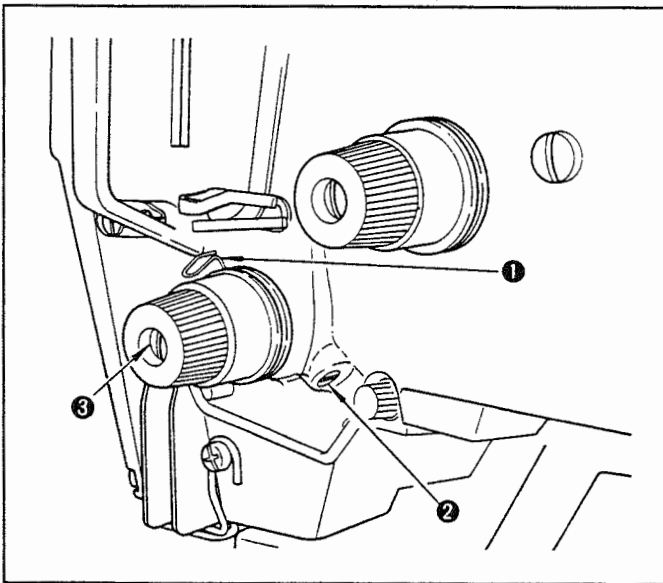
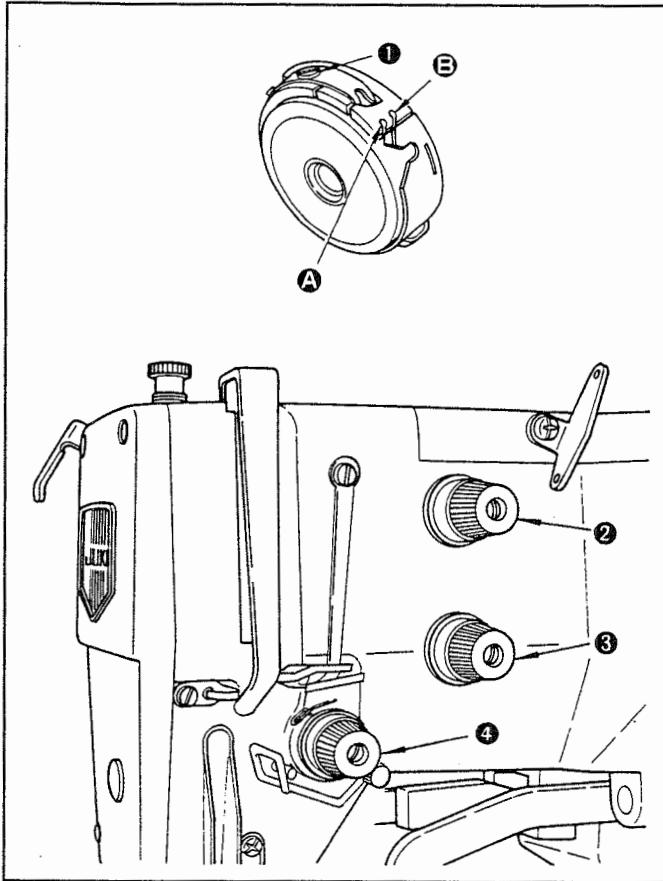

### (1) Thread tension for purl stitching

- 1) Pass the bobbin thread through groove **A** in the bobbin case, and using tension screw **1** adjust the thread tension so that it is approximately 5 ~ 10 g.
- 2) Adjust thread tension controller No.2 (middle bartacking) **3** and thread tension controller No. 3 (finished bartacking) **4** so that bartacking can be sewn in beautiful whipped stitches.
- 3) Adjust thread tension controller No. 1 **2** so that an adequate crest on the parallel side seam can be obtained.

### (2) Thread tension for whipped stitching

- 1) Pass the bobbin thread through groove **B** in the bobbin case, and using tension screw **1** adjust the thread tension so that it is approximately 20 ~ 30 g.
- 2) Allow the tension disc of thread tension controller No. 1 **2** to completely float.
- 3) Adjust the seam formation in the parallel side seam and bartacking using thread tension controller No. 2 **3**, and thread tension controller No. 3 **4**.

### (3) Thread take-up spring (purl stitching)

- 1) When adequate thread take-up amount of thread take-up spring **1** is 8 ~ 10 mm, and the proper spring tension when starting to sew is 6 ~ 10 g.
- 2) When changing the thread take-up amount of the thread take-up spring, loosen screw **2**, fit the small screwdriver into the slotted head of thread tension post **3**, and turn it to obtain the desired take-up amount.
- 3) When changing the tension of the thread take-up spring, fit the small screwdriver into the slotted head of thread tension post **3**, and turn it to obtain the desired tension, with screw **2** tightened.

Turning the post clockwise will increase the tension of the spring, while turning it counter-clockwise will decrease the tension.



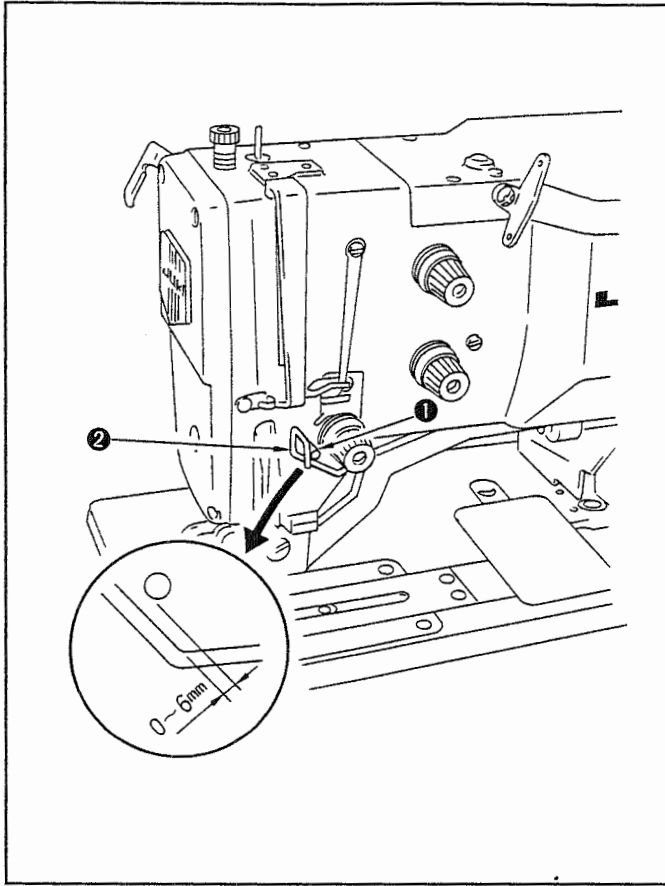

#### (4) Adjusting the thread pulling amount

Set the machine in the stop motion state. Now, remove plug ③, loosen screw ④ (one screw only) and adjust the clearance provided between stopper ① and thread pulling arm ② properly. The larger the clearance provided between stopper ① and thread pulling arm ② becomes, the more the thread pulling amount will be.

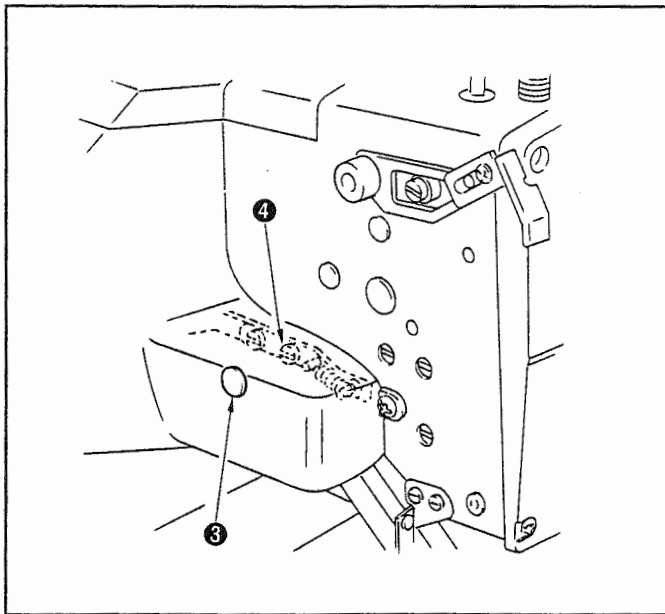



### 23. Adjusting the overedging length (material feed amount)

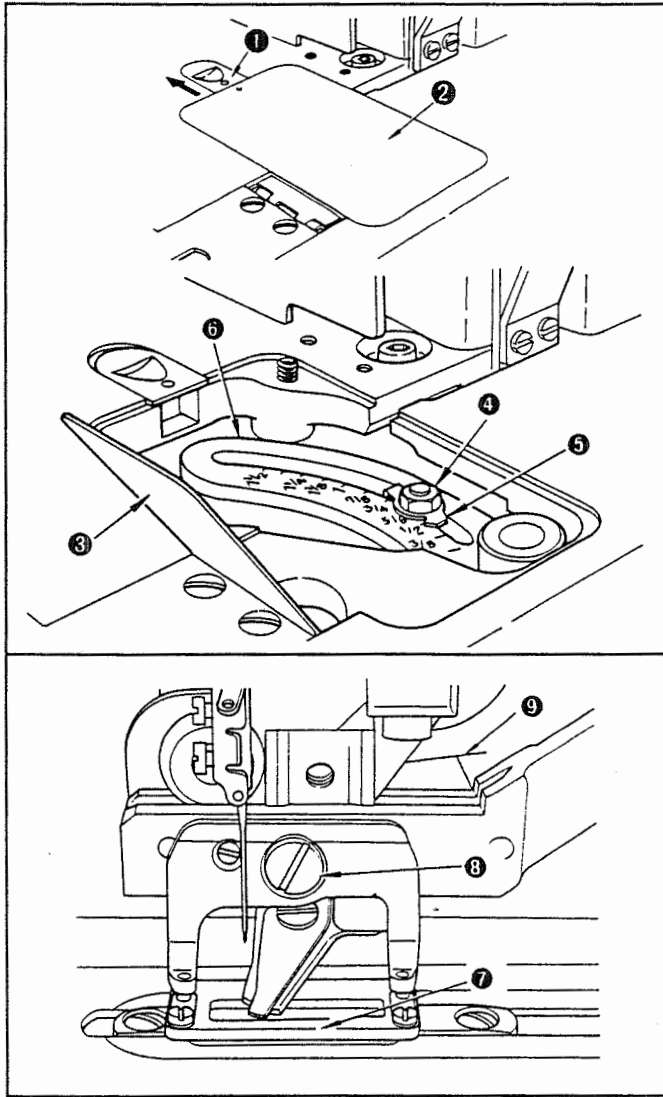

- 1) Pull claw ① in the direction of the arrow, remove top cover ②, and raise cover ③.
  - 2) Loosen nut ④ with the wrench supplied with the unit, align pointer ⑤ with the desired value on the scale of length regulating shaft bell crank ⑥ (the same value as the width of the cloth cutting knife), and tighten nut ④. Be sure not to remove nut ④.
  - 3) Make a fine adjustment while trial sewing so that the knife does not cut the bartacking seam.
- Replacing the work clamp check  
Use work clamp check ⑦ of which length is almost the same as that of the buttonhole. Loosen setscrew ⑧, and the work clamp check and work clamp check holder can be replaced together as one set.

### 24. Replacing the cloth cutting knife

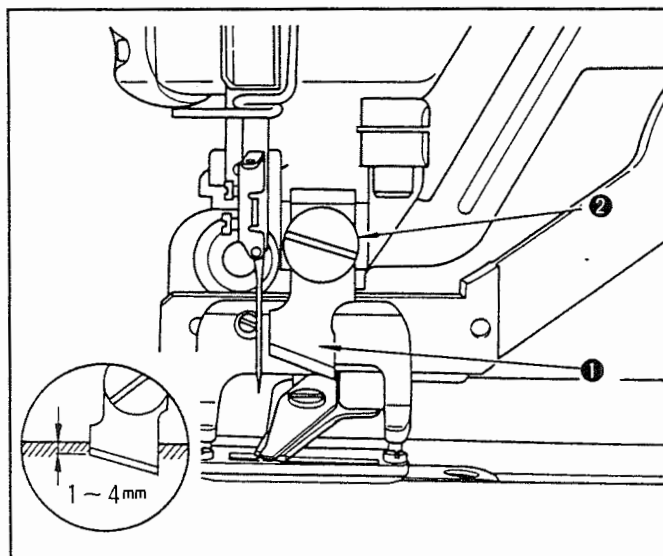

To sharpen the knife or replace the knife with a new one, follow the procedure described below.

- 1) Loosen knife setscrew ②, and remove knife ① together with the washer.
- 2) Install the knife so that a 1 ~ 4 mm clearance is obtained between the knife and the throat plate surface when the knife goes down to its lowest position. Then tighten knife setscrew ②.

**(Caution)** Be sure to use the washer with the screw.



25. Adjusting the overedging width (stitch width and bartacking width) and the overedging standard position

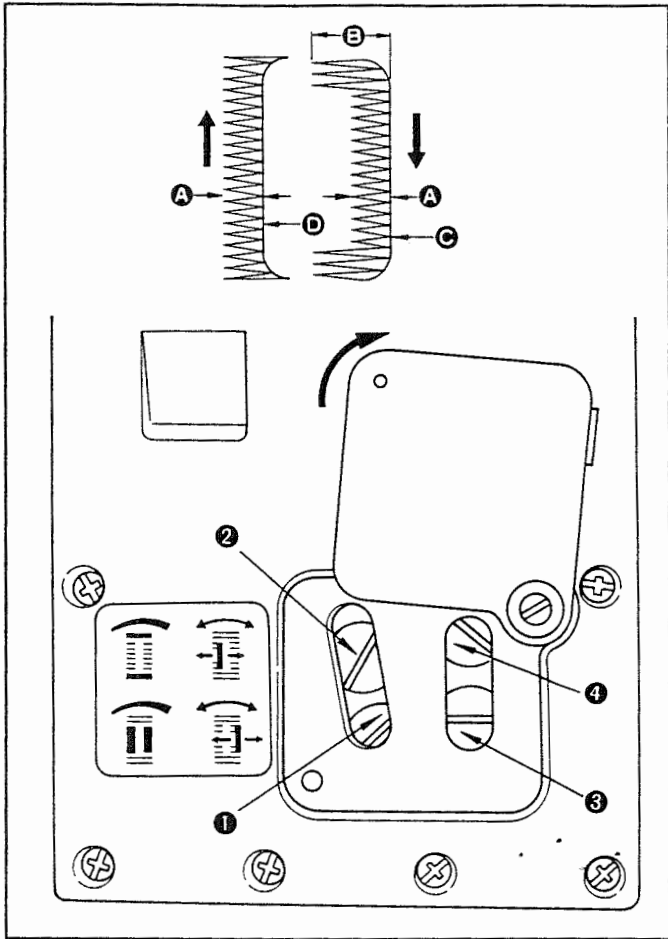

● The swing motion of the needle is made as the needle shifts to the left from the position furthest to the right which is taken as the standard position.

Adjust the stitch width as follows.

- 1) Turning screw ① clockwise will widen the stitch width A.

Turning it counterclockwise will reduce the stitch width.

- 2) Turning screw ② clockwise will widen the bartacking width B.

Turning it counterclockwise will reduce the bartacking width.

- 3) Turn screw ③, and adjust the position of right standard line C so that the knife does not cut the seam.

The standard line shifts to the right when screw ③ is turned clockwise, and to the left when it is turned counterclockwise.

- 4) Finely adjust the stitch width and the position of the standard line while trial sewing.

Adjust in the following order: change the stitch width → check the clearance between the knife and the parallel side seam → adjust the position of the right standard line → change the bartacking width.

- 5) The position of left standard line D does not need to be adjusted, as it is fixed even if the stitch width is changed. Only when the knife cuts into the left standard line must you adjust the position of the left standard line with screw ④.

Turning screw ④ clockwise will shift the standard line to the right, while turning it counterclockwise will shift it to the left.

**(Caution)** If the overedging width is set with a large value (the bartacking width is 4 mm or more), turn the pulley by hand to ensure that the needle does not hit the work clamp check during its stroke.



## 26. Changing the number of stitches

Small gear			Large gear	
Symbol	No. of stitches of small gear	Part No.	No. of stitches of large gear	Part No.
A	56	13756200	370	13756309
B	60	13756408	347	13756507
C	65	13756606	326	13756705
D	68	13766804	306	13756903
E	72	13757000	288	13757109
F	76	13757208	271	13757307
G	81	13757406	256	13757505
H	86	13757604	242	13767703
I	91	13757802	228	13757901
J	86	13758008	216	13758107
K	101	13758206	204	13758305
L	107	13758404	194	13758503
M	11	13758602	183	13758701
N	119	13758800	174	13758909
O	126	13759006	164	13759105
P	133	13769204	156	13759303
Q	140	13759402	148	13759501

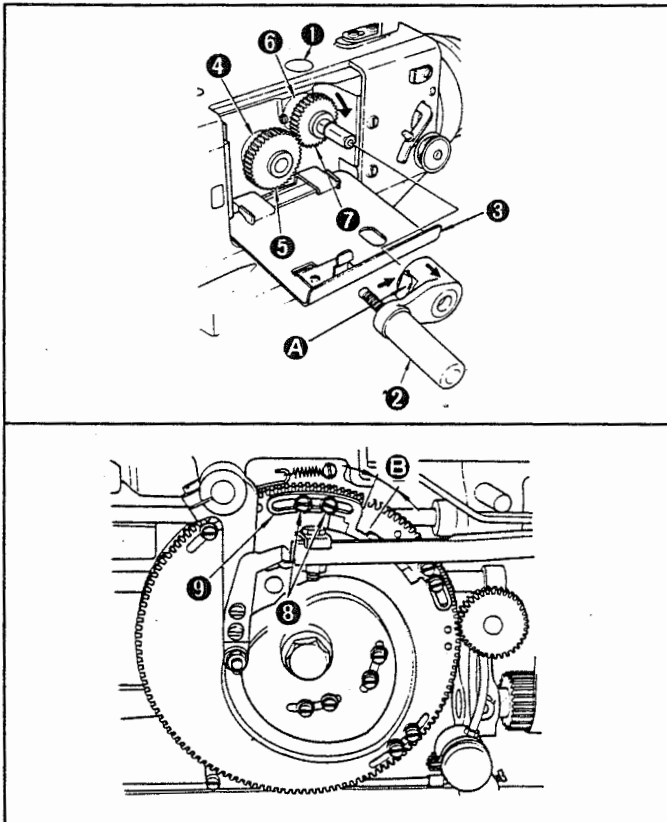

### (1) Replaceable gears

- 1) The number of stitches shown in the table can be sewn by replacing the gears.
- 2) All the gears have engraved letters of the alphabet such as A, B, C etc. and engraved figures such as 164, 126 etc.
- 3) Use gears with the same letters of the alphabet.
- 4) The engraved figure on the rear face of the gear (surface side of the top face cover marked by ①) indicates the number of stitches.

**(Caution)** The replaceable gears used with the LBH-781 or the like cannot be used.

### (2) Installing the gears

- 1) Press handle stopper **A** of manual handle **②** in the direction of the arrow, and remove the handle. Then open cover **③**.
- 2) Fit gear **⑤** on the pin of replaceable gear base **④** located nearest the operator.
- 3) Fit gear **⑦**, turning it in the direction of the arrow on the pin of replaceable gear base **⑥** located on the rear face (on the marked side).
- 4) After having attached the gears, close cover **③**, and install manual handle **②**.

**(Caution)** Be sure that you do install the manual handle. If the sewing machine is actuated with the manual handle removed, the gears may spring out from the pins.

- Adjusting the low-speed cam (general-use motors) (The low-speed cam of the electronic-stop motors need not be adjusted.)

Loosen setscrews **⑧**, and adjust the position of low speed cam **⑨**, so that clearance **B** becomes the value shown in the table.

Number of stitches	Clearance <b>B</b>
Max. 86	18 mm
Min. 164	0
126	10 mm



## 27. Adjusting the pressing pressure of the work clamp check

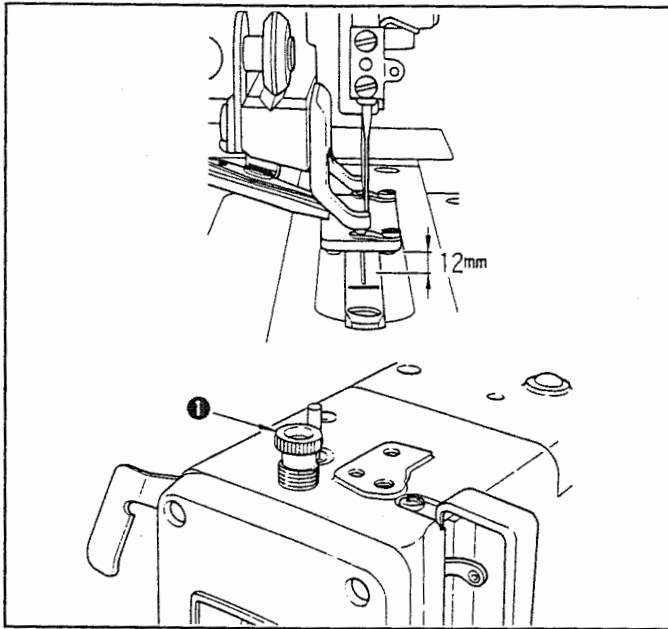

- 1) The lift of the work clamp check will be 12 mm when the pedal is fully treadled. (The amount of lift can be adjusted up to 14 mm maximum.)
- 2) Adjust the pressing pressure of the work clamp check using pressure adjusting screw ①. Tighten the adjusting screw, and the pressure will be increased. This will prevent the material from puckering.

## 28. Needle-to-hook relationship

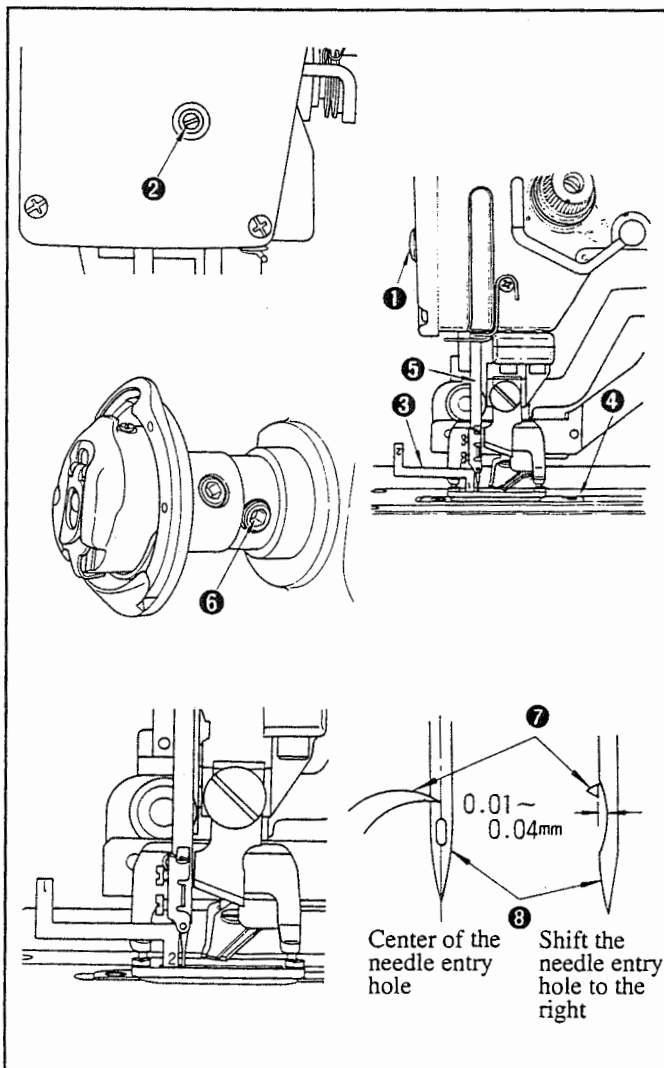

● Adjust the timing between the needle and the hook as follows:

- 1) Bring the needle bar to the lowest position of its stroke when the needle drops into the center of the needle entry hole of the throat plate.
- 2) Remove rubber cap ①, and loosen needle bar connection screw ②.

**(Determine the needle bar height.)**

- 3) Insert section "1" of timing gauge ③ between throat plate ④ and the lower end of needle bar ⑤, and allow the needle bar to hit the gauge.
- 4) Tighten needle bar connection screw ②.

**(Determine the position of the hook.)**

- 5) Loosen two hook sleeve setscrews ⑥ using the allen wrench supplied with the unit.
- 6) Turn the drive pulley in the normal direction so that the needle bar starts to go up from its lowest position.
- 7) Align blade point ⑦ of the hook with the center of needle ⑧, when section "2" of the timing gauge is inserted between the throat plate and the lower end of the needle bar so as to allow the needle bar to hit the gauge (the needle is in the center of the needle entry hole of the throat plate.)

Now temporarily fix the blade point. Then shift the needle to the right and ensure that there is a 0.01 ~ 0.04 mm clearance between the blade of the hook and the needle. Now tighten up the hook driving shaft with the hook sleeve setscrew.

**(Caution)** If stitch skipping occurs, replace the timing gauge with the K type one and readjust the relation between the needle and the hook. In this case, if extremely inadequate crest of seam is produced, lift the needle bar by approximately 0.5 mm from the current position and properly adjust the needle to hook relation again.



### 29. Adjusting the tension of the timing belt

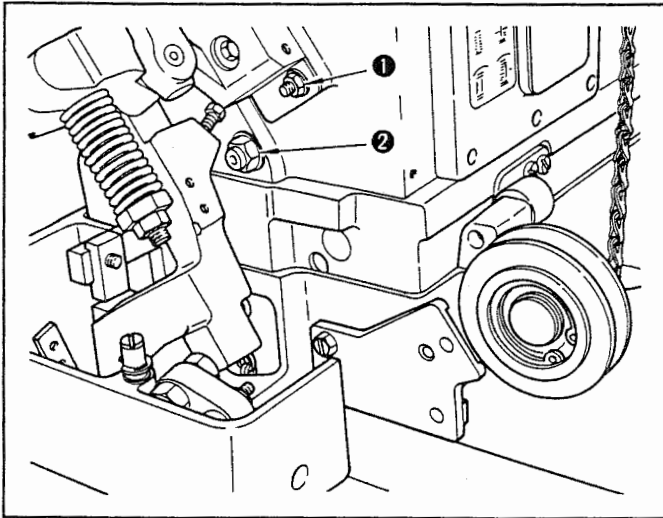

- 1) The tension of the timing belt which drives the hook driving shaft is determined by a spring.
- 2) When re-adjusting the belt tension, loosen adjusting nut ① and idler shaft locknut ② (this locknut is a left-hand nut, so care must be taken). Properly adjust and tighten the nuts in the order of ① and ②.

### 30. Adjusting the needle thread cutter scissors

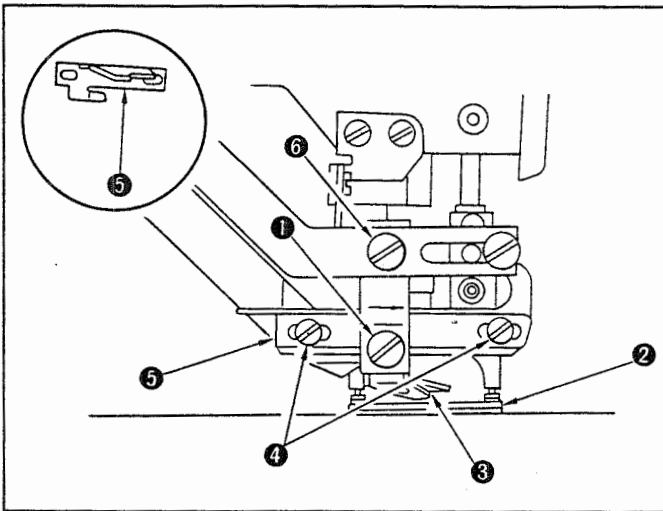

#### (1) Installing the scissors

Loosen screw ①, and fix scissors ③ when a clearance of 1 mm is provided between the flat section of scissors ③ and work clamp check ②. In this state, approximately three to nine plies of men's shirt material can be sewn with overlapped.

If the difference of thickness of the overlapped section of the material is larger, increase the clearance between the scissors and the work clamp check. To shorten the thread remaining after thread trimming, decrease the clearance between work clamp check ② and scissors ③ as long as they do not come in contact with each other.

#### (2) Longitudinal position of the scissors

Loosen setscrew ⑥ and properly adjust the longitudinal position of the scissors.

#### (3) Opening timing of the scissors

Adjust so that the scissors start gradually opening after a 2.5 ~ 3 mm seam has been made.

Adjust the timing by loosening screws ④ and by moving needle thread cutter driving cam ⑤ in a longitudinal direction. Move the cam toward you, and the scissors will start opening earlier.

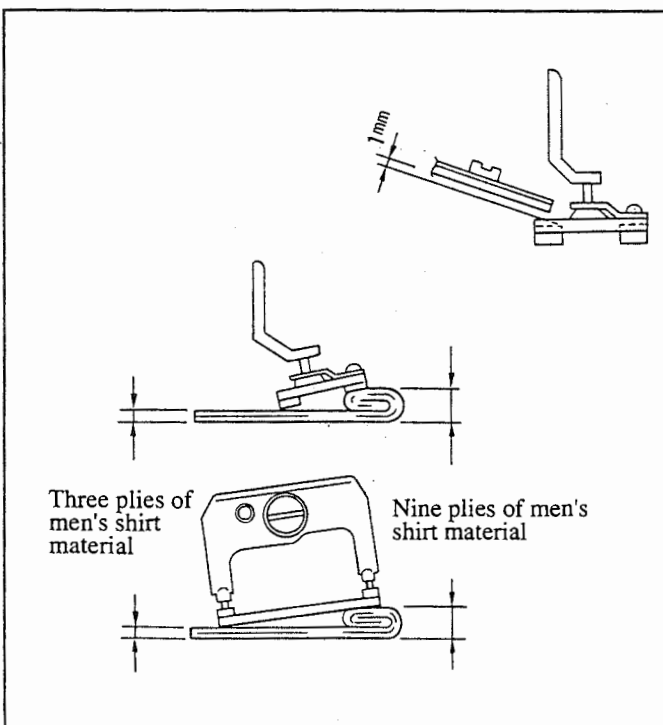



### 31. Adjusting the bobbin thread cutter scissors

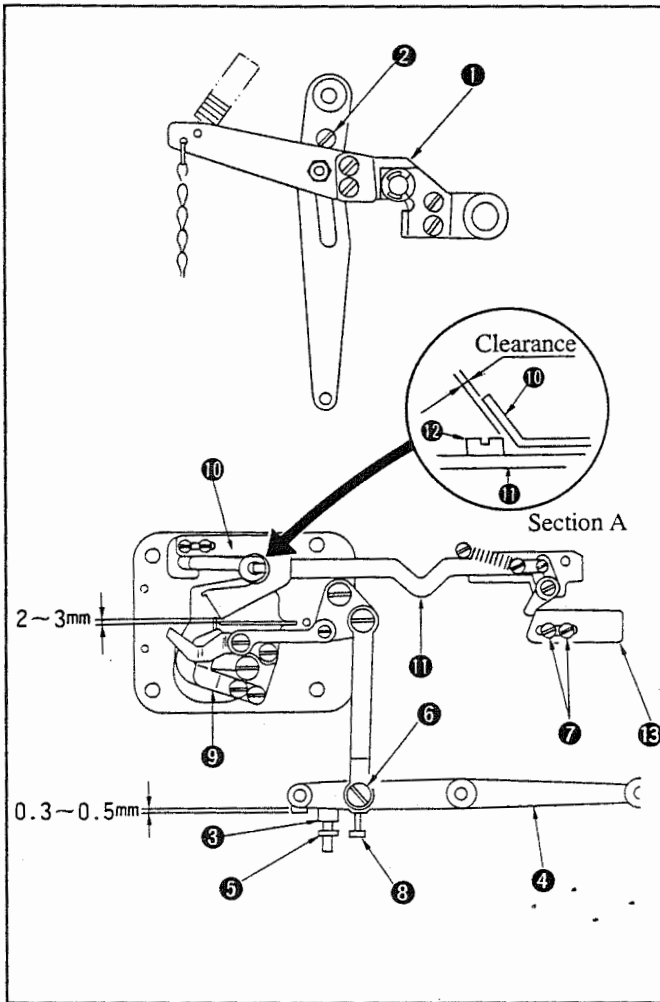

#### (1) Adjusting the stopper of the bobbin thread cutter lever

Attach the stopper of the bobbin thread cutter lever using nut ⑤ so that there is a 0.3 ~ 0.5 mm clearance between stopper ③ of the bobbin thread cutter lever (asm.) and lever ④ of the bobbin thread cutter when work clamp check lifting lever ① is aligned with work clamp check lifter stopper A ②.

#### (2) Operating timing of the bobbin thread cutter scissors

Adjust the operating timing of the bobbin thread cutter scissors by loosening setscrew ③ and by turning bobbin thread cutter link shaft ⑥.

**(Caution)** Confirm that the top end of looper thread guide plate ⑨ is spaced 1 to 3 mm from the edge of the needle hole when work clamp check lifting lever ① is aligned with work clamp check lifter stopper A ②. If the looper thread guide plate is too near to the center of the knife groove, the plate may come in contact with the needle.

#### (3) Bobbin thread releasing timing of the bobbin thread cutter scissors

Adjust the bobbin thread releasing timing of the bobbin thread cutter scissors by loosening screw ⑦ and moving bobbin thread cutter driving cam ⑬ back or forth. Move the cam toward you, and the bobbin thread cutter scissors will release the bobbin thread earlier.

**(Caution)** At the time of stop motion, if bobbin thread retaining spring ⑩ comes in contact with bobbin thread retaining spring releasing screw ⑫, as illustrated in the figure, section A will fail to securely retain the bobbin thread. As a result, the bobbin thread will be likely to slip off section A.

### 32. Adjusting the dropping timing of the cloth cutting knife

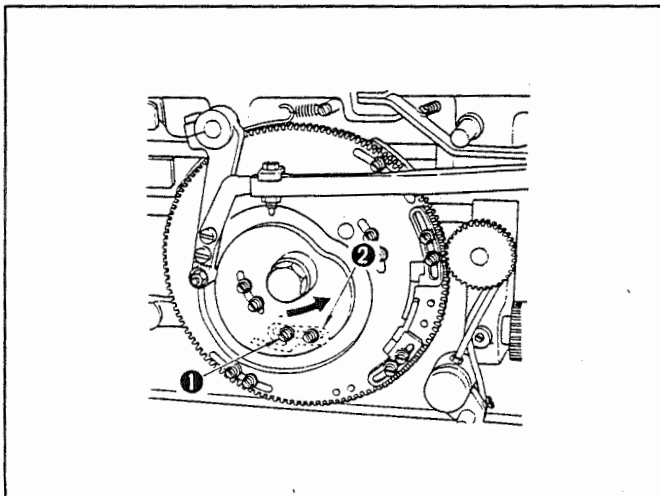

- 1) Loosen setscrew ①, move knife driving cam ② in the direction of the arrow, and the cloth cutting knife will drop earlier. Moving the cam in the reverse direction will delay the knife dropping timing.
- 2) Adjust so that the knife drops 2 ~ 3 stitches before the sewing machine stops running.



### 33. Adjusting the speed reduction mechanism (general-use motor)

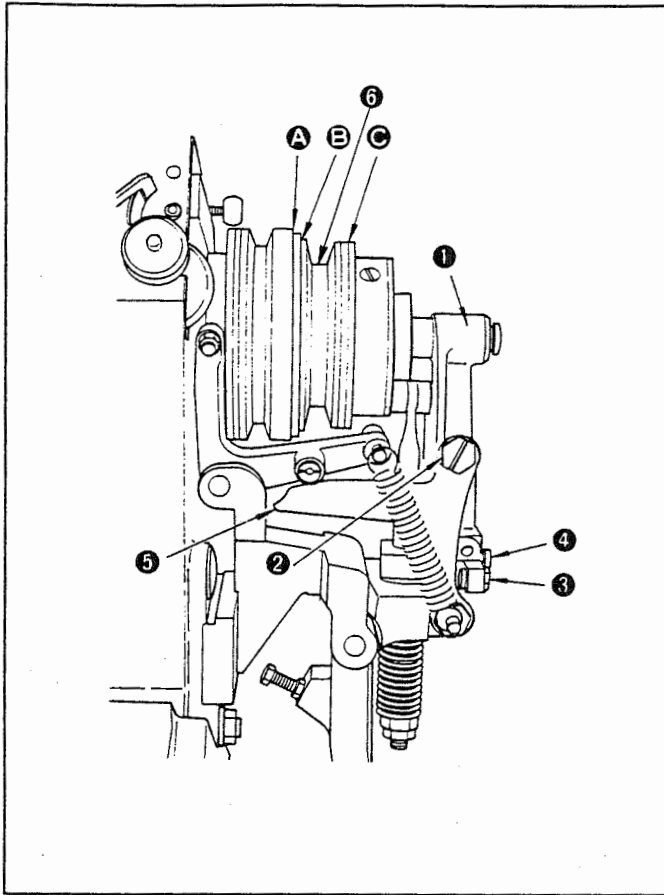

- 1) When the machine stops:  
A clearance **A** of approximately 0.45 mm is obtained with the low-speed taper clutch, while a clearance **B** of approximately 0.4 mm is obtained with the high-speed taper clutch. A clearance **C** of 0.25 ~ 0.35 mm is obtained with the high-speed disc clutch. Move stop-motion frame **1** to set the sewing machine to the low-speed operation mode. Clearance **A** will now become 0 mm. When the machine is set to the high-speed operation mode, clearances **B** and **C** will both be 0 mm.
- 2) To adjust the clutch clearance:  
Loosen screw **2** in the clutch change-over cam, also loosen adjusting nut **3** and turn adjusting screw **4** clockwise to decrease clearance at side **A** and increase clearance at side **C**, or counterclockwise to increase the former and decrease the latter. Once clutch change-over cam **5** is properly positioned by adjusting screw **3**, tighten adjusting nut **3**. Then also tighten screw **2** in the clutch change-over cam.

**(Caution)** Take care not to hold high speed pulley **6** when transporting or unpacking the machine unless so doing is quite necessary.

### 34. Speed control (electronic-stop motor)

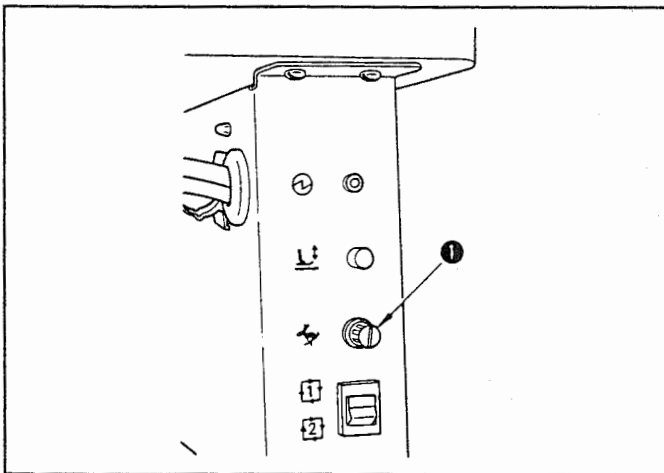

- 1) In the high-speed operation mode, the sewing speed can be adjusted by turning knob **1** in the control box.
- 2) Turn the knob clockwise, and the sewing speed will be increased. Turn it counterclockwise, and the sewing speed will be decreased. Set the sewing speed according to the sewing specifications.



### 35. Soft start (electronic-stop motor)

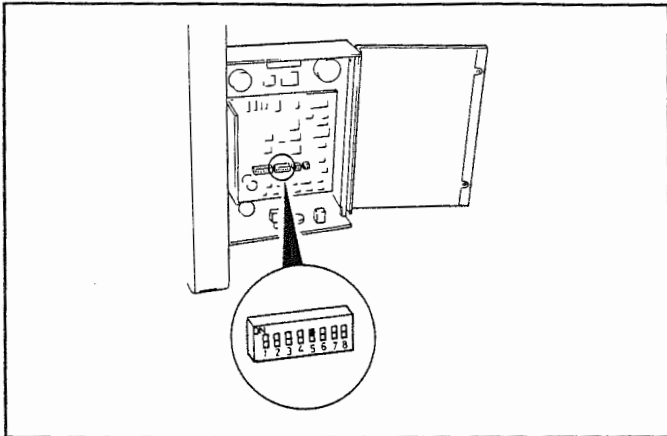

Set the DIP switch 4-5 to its ON position in the control box, and you can make the sewing machine run at a low speed for two stitches at the start of sewing.

### 36. Adjusting the needle stopping position (electronic-stop motor)

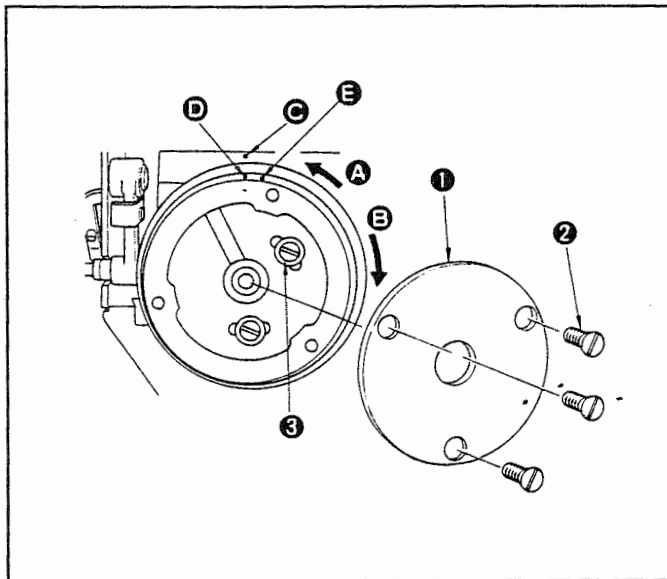

- 1) The standard stopping position of the needle is where red marker dot **C** of the arm is aligned with white marker dot **D** on the driving pulley.
- 2) Remove setscrew **2** of pulley cover **1**. Run the sewing machine in the cycle sewing mode and then stop the machine. If the sewing machine stops after overrunning the predetermined stopping position, loosen setscrew **3**, and move it in direction **A**.
- 3) On the other hand, if the sewing machine stops before reaching the predetermined stopping position, move the setscrew in direction **B**. After completing the adjustment, reinstall pulley cover **1**.

**(Caution)** Be sure not to run the sewing machine with screw **3** loosened. Do not completely remove the screw. Only loosen it.

Adjust so that red marker dot **C** engraved on the machine arm is aligned with white marker dot **E** on the driving pulley. This will reduce the frequency of slip off of thread.

### 37. Adjusting the stop-motion solenoid (electronic-stop motor)

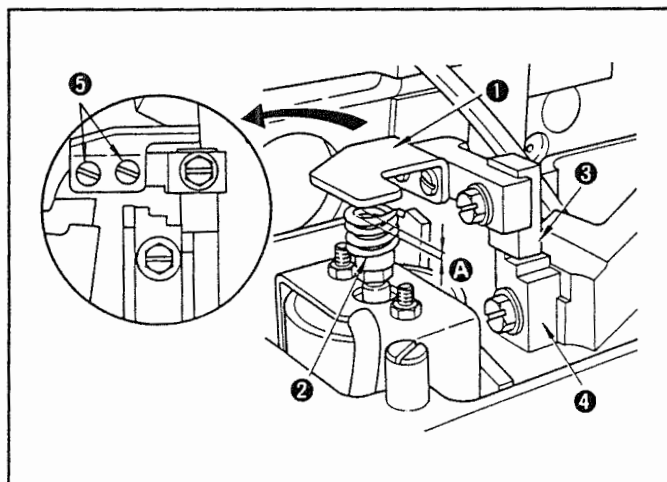

- 1) In the high-speed operation mode, a clearance of **A** 0 ~ 0.5 mm between presser plate **1** and presser bar spring **2** is normal.
- 2) To adjust, turn off the power switch, and fully treadle the actuator pedal to engage hook B **3** with hook A **4**, as shown in the figure. Then lower presser bar spring **2** by hand, and loosen setscrew **5** of presser plate **1** so that a clearance of **A** 0 ~ 0.5 mm is obtained.



### 38. Troubleshooting (when sewing)

Problem	Cause	Corrective measures	Page
1. The needle thread breaks.	① The thread tension controlled by the thread tension controller No. 1 is too strong.	· Decrease the thread tension controlled by the thread tension controller No. 1.	12
	② The tension of the thread take-up spring is too strong, or the amount of movement of the thread take-up spring is too great.	· Decrease the tension of the thread take-up spring, or reduce the amount of movement of the thread take-up spring.	12
	③ The blade point of the hook is blunt or damaged.	· Buff the blade point of the hook or replace the hook.	17
	④ The hook timing is incorrect.	· Adjust the hook timing using the timing gauge.	17
	⑤ The thread path is damaged.	· Buff the thread path with emery paper.	17
	⑥ Improper attaching of the needle.	· Re-adjust the facing direction or the height of the needle.	9
	⑦ The needle is too thin.	· Replace the needle with a thicker one.	9
	⑧ The tip of the needle is damaged.	· Replace the needle. · Readjust the stopping position of the needle. (Electronic-stop motor)	9 21
2. The needle thread slips off.	① The needle thread cutting scissors start opening earlier.	· Shift needle thread cutter driving cam A away from you.	18
	② Whipped stitching is not possible at the sewing start point.	· Decrease the thread tension controlled by the thread tension controller No. 3. · Increase the thread pulling amount.	12 13
	③ Improper needle threading.	· Re-thread the needle thread properly.	10
3. A loose seam formation in the parallel side seam.	① The thread tension controlled by the thread tension controller No. 1 is too low.	· Increase the thread tension controlled by the thread tension controller No. 1.	12
	② The bobbin thread tension is too high.	· Decrease the bobbin thread tension. (The proper tension of the bobbin thread for purl stitching is 5 ~ 10 g)	12
4. A loose seam formation at the sewing start position.	① The thread tension controlled by the thread tension controller No. 3 is too low.	· Increase the thread tension controlled by the thread tension controller No. 3.	12
	② The position of the needle thread cutting scissors is too high.	· Lower the scissors, provided that they do not come in contact with the work clamp check. · Increase the thread pulling amount.	18 13
5. In bartacking section No. 1, the needle thread appears on the wrong side of the material, and is formed into balls.	① The thread tension controlled by the thread tension controller No. 2 is too low.	· Increase the thread tension controlled by the thread tension controller No. 2.	12
	② The bobbin thread tension is too high.	· Decrease the bobbin thread tension. (5 ~ 10 g)	12
6. In bartacking section No. 2, the needle thread appears on the wrong side of the material, and is formed into balls.	① The thread tension controlled by the thread tension controller No. 3 is too low.	· Increase the thread tension controlled by the thread tension controller No. 3.	12
	② The bobbin thread tension is too high.	· Decrease the bobbin thread tension. (5 ~ 10 g)	12
7. The seam floats.	① The bobbin thread tension is too low.	· Increase the bobbin thread tension.	12
	② The bobbin thread slips off from the bobbin case.	· Re-thread the bobbin case properly.	9
8. Stitches are skipped.	① The buttonhole is too small for the work clamp check.	· Replace the work clamp check with a smaller one.	12
	② The material is light-weight and fluttering.	· Delay the timing between the needle and the hook. (Use the K type gauge.)	14
	③ The needle is not properly attached.	· Re-adjust the facing direction or the height of the needle.	9
	④ The needle is bent.	· Replace the needle.	9
	⑤ The blade point of the hook is blunt or damaged.	· Buff the blade point of the hook, or replace the hook.	14



### 39. Troubleshooting (during an operation other than sewing)

Problem	Cause	Corrective measures	Page
1. The starting pedal will not move. (The work clamp check lifter lever has not returned to its upper resting position.)	<ul style="list-style-type: none"> <li>① Thread waste or the like is accumulated on the throat plate, throat plate mounting base, or the bobbin thread cutting scissors.</li> <li>② The thread pulling arm comes in contact with the hook.</li> </ul>	<ul style="list-style-type: none"> <li>· Tilt the sewing machine head, and clean off the above sections.</li> <li>· As the sewing machine is not in the stop-motion position, set the machine to the stop-motion position. (General-use motor)</li> <li>· As the sewing machine is not in the normal stopping position, re-adjust the stopping position. (Electronic-stop motor)</li> </ul>	21
2. The sewing machine will not run in the high-speed operation mode when the starting pedal is fully depressed. (General-use motor)	<ul style="list-style-type: none"> <li>① The low-speed operation stopper is actuated.</li> <li>② There is too large a clearance in the high-speed clutch.</li> </ul>	<ul style="list-style-type: none"> <li>· Release the low-speed operation stopper.</li> <li>· Adjust the clutch switching cam to decrease the clearance in the high-speed clutch.</li> </ul>	10 20
3. Too great a noise is generated in the stop-motion. The sewing speed does not decrease at the end of sewing. (General-use motor)	<ul style="list-style-type: none"> <li>① Inadequate positioning of the low-speed cam when the number of the stitches is small.</li> <li>② The low-speed V-belt is excessively loose.</li> <li>③ The clearance at the low-speed clutch is too large.</li> </ul>	<ul style="list-style-type: none"> <li>· Re-adjust the position of the low-speed cam to obtain a longer sewing distance in the low-speed operation mode.</li> <li>· Hang the V-belt on the tension pulley.</li> <li>· Increase the pulley tension.</li> <li>· Adjust the clutch switching cam to decrease the clearance in the low-speed clutch.</li> </ul>	16 6 20
4. Stop-motion error (General-use motor)	<ul style="list-style-type: none"> <li>① The stop-motion frame unit needs to be lubricated.</li> <li>② The brake works excessively causing the stop-motion frame to float.</li> </ul>	<ul style="list-style-type: none"> <li>· Lubricate the stop-motion frame unit.</li> <li>· Re-adjust the position of the brake disc.</li> </ul>	8 20
5. The sewing machine head is not properly lubricated.	<ul style="list-style-type: none"> <li>① Insufficient oil in the sewing machine head base.</li> <li>② Dust is accumulated on the felt pad in the lubrication base.</li> </ul>	<ul style="list-style-type: none"> <li>· Refill with lubricating oil up to the HIGH mark on the sewing machine head base.</li> <li>· Wash the felt.</li> </ul>	8
6. The knife will not drop.	<ul style="list-style-type: none"> <li>① Inadequate positioning of the low-speed cam when the number of stitches is small.</li> <li>② Inadequate positioning of the knife driving cam.</li> </ul>	<ul style="list-style-type: none"> <li>· Re-adjust the position of the low-speed cam.</li> <li>· Re-adjust the timing of the knife drop.</li> </ul>	16 19
7. The work clamp check will not go up. (Electronic-stop motor)	<ul style="list-style-type: none"> <li>① Hook A and hook B remain engaged when the sewing machine stops.</li> </ul>	<ul style="list-style-type: none"> <li>· Re-adjust by loosening the presser plate of the stop-motion solenoid.</li> </ul>	21
8. The needle is broken.	<ul style="list-style-type: none"> <li>① The needle is bent.</li> <li>② The needle comes in contact with the blade point of the hook.</li> <li>③ The needle thread cutting scissors come in contact with the needle when they start opening.</li> <li>④ The lower resting position of the needle is so low that the needle thread cutting scissors come in contact with the needle when the scissors start closing. (Electronic-stop motor)</li> </ul>	<ul style="list-style-type: none"> <li>· Replace the needle.</li> <li>· Re-adjust the positions of the needle and hook.</li> <li>· Re-adjust the position of the scissors.</li> <li>· Re-adjust the resting position of the needle.</li> </ul>	9 17 18 21





# JUKI

## JUKI CORPORATION

HEAD OFFICE  
8-2-1, KOKURYO-CHO,  
CHOFU-CITY, TOKYO 182, JAPAN

BUSINESS OFFICE  
1-23-3, KABUKI-CHO,  
SHINJUKU-KU, TOKYO 160, JAPAN

PHONE : 03(3205)1188, 1189, 1190  
FAX : 03(3203)8260, (3205)9131  
TELEX : J22967,232-2301

To order or for further information, please contact:

Please do not hesitate to contact our distributors or agents in your area for further information when necessary.

※The description covered in this instruction manual is subject to change for improvement of the commodity without notice.