

Before operating your JUKI Lock-stitch Machine, please read this Instruction Manual carefully in order to operate it in the correct and efficient manners.

CAUTIONS IN OPERATION

1. The machine should rotate counterclockwise as observed from the pulley. Take care not to rotate the machine in the opposite direction.
2. Never start the machine before filling the machine base with lubricating oil.
3. Remove the bobbin case and the needle thread from the machine before performing the trial operation.
4. Clean up the sewing hook and the bobbin thread trimmer every day after sewing work. Also check the level of the lubricating oil.
5. Never bring your fingers or hair close to, or place anything on the handwheel, V-belt, bobbin winder wheel or motor during operation. It may lead to serious personal injuries.
6. If your machine is provided with a belt cover, finger guard and eye guard, never operate your machine with any of them removed.

1. MOTOR PULLEY AND V BELT

1. Motors of 300W, 4-pole are used for single-phase or three-phase operation. (If a 250W motor has to be used, operate the machine at 3,100 s.p.m. or less.)
2. M-type V belts are used.
3. Refer to the following table for the motor pulleys, V belt length, and sewing speed.

Sewing speed	Frequency	Motor pulley Part No.	High speed V belt	Low speed V belt
3,600 s.p.m.	50Hz	B7262-781-000A	45 inch	42 inch
	60Hz	B7263-781-000A	43 inch	41 inch
3,300 s.p.m.	50Hz	B7256-781-000A	44 inch	42 inch
	60Hz	B7257-781-000A	43 inch	42 inch
3,000 s.p.m.	50Hz	B7253-781-000A	44 inch	42 inch
	60Hz	B7254-781-000A	42 inch	41 inch
2,800 s.p.m.	50Hz	B7258-781-000A	43 inch	42 inch
	60Hz	B7259-781-000A	41 inch	41 inch

(V belt Part No.: MTJ-VM00□□00, □□: V belt length)

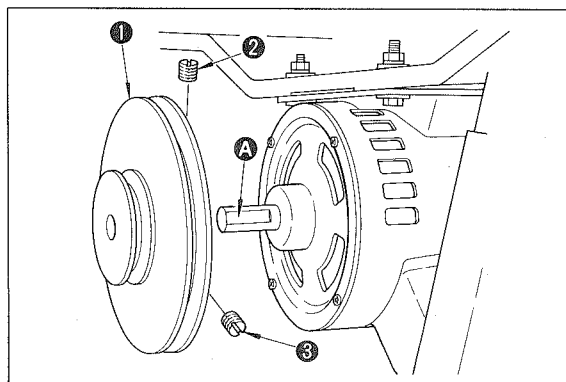

★ How to install motor pulley

Place motor pulley ① into the motor shaft so that flat part ① of the motor shaft aligns with first setscrew ②. Then securely tighten setscrews ② and ③.

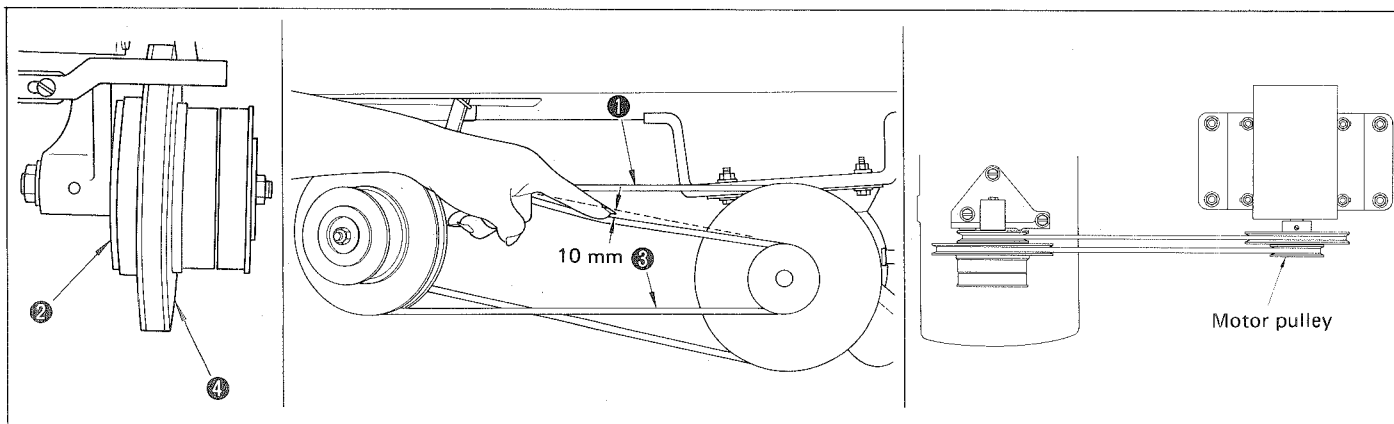

★ How to install V belt

1. Mount high-speed V belt ① on accelerating pulley ② and the large diameters of the motor pulley.
2. Mount low-speed V belt ③ on low-speed pulley ④ and the small diameters of the motor pulley.
3. By moving the motor from side to side, adjust the tension of V belts ① and ③ so that they give an approx. 10 mm slack when their middle portions are pushed lightly by hand.
4. Move the motor pulley back and forth to align V belts ① and ③.

2. SETTING UP THE THREAD STAND

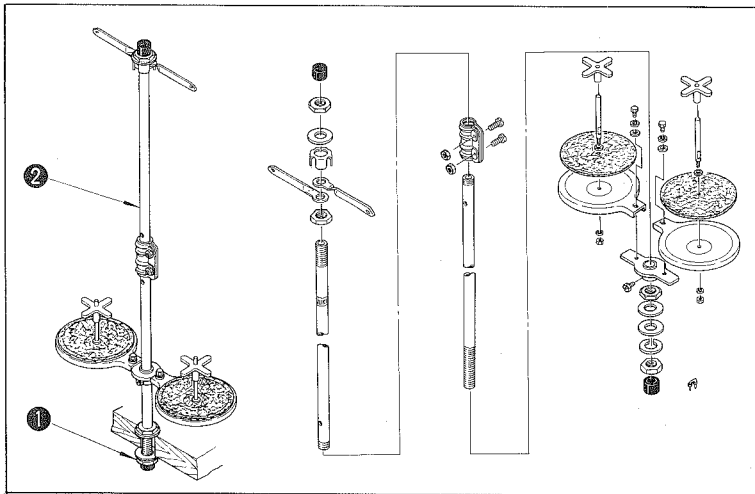

Assemble the thread stand, and fix it in the table hole. Then tighten lock nut ① to fix the thread stand. If ceiling wiring can be made, pass the power cable through spool rest rod ②.

3. SETTING UP THE MACHINE HEAD

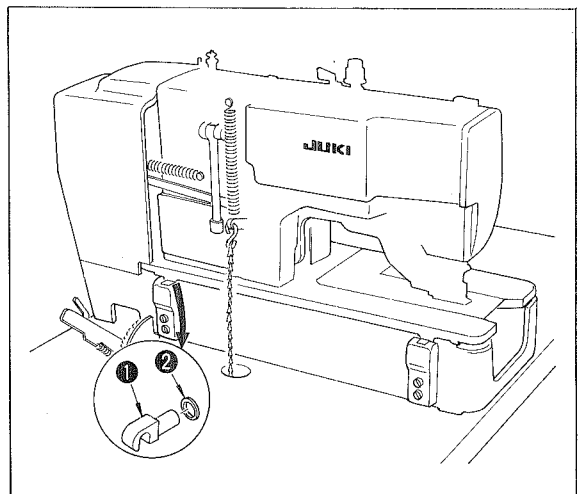

Putting cushion ② into hinge ⑩, insert hinge ⑪ into the machine head. Then, place the machine head on the machine base.

4. ATTACHING THE FLAT BELT

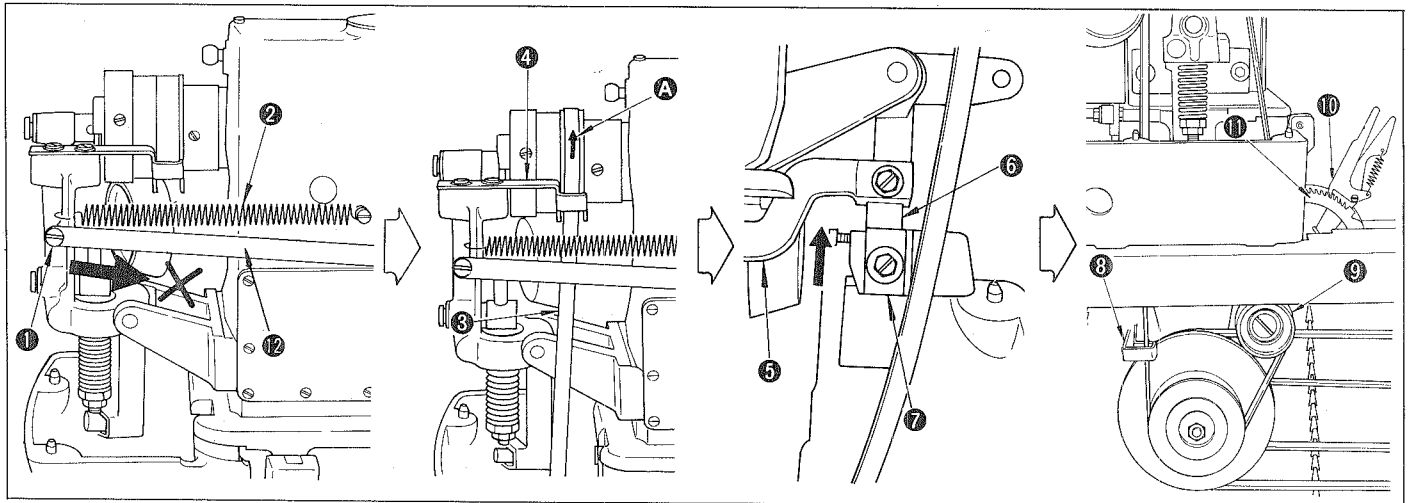

1. Removing screw ①, remove spring ② from the suspension screw.

At this time, be careful not to push the starting link driving rod in the arrowed direction.

2. Pass belt ③ through belt shifter ④ so that the belt rotates in arrow A direction.

3. Reinstall screw ① and spring ②.

4. Lift tripping lever ⑤ in the direction, pass the belt between latch B ⑥ and latch A ⑦.

5. Passing belt shifter ⑧ of the speed transmitter, attach the belt onto tension pulley ⑨.

6. Put fixing pawl ⑩ in the second groove from the bottom of ratchet ⑪ to provide the belt with tension.

(NOTE) Some expansion or contraction in the belt caused by temperature or humidity may make it rather difficult to install the belt. However, the belt will restore its original length while in use.

5. INSTALLATION/REMOVAL OF BELT COVER

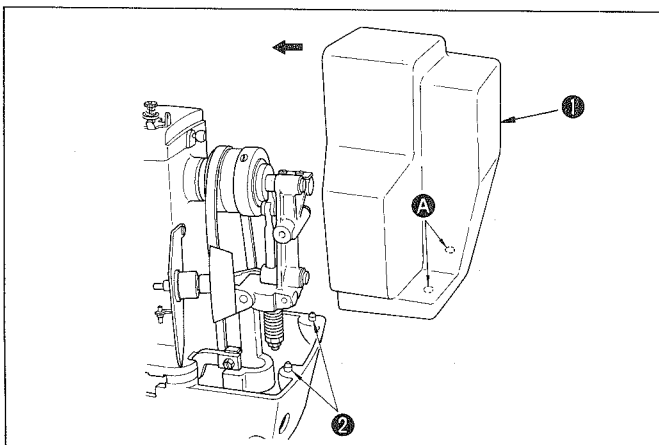

Aligning guide pin ② with hole A in belt cover ①, push the belt cover in the arrow direction until it snaps.

For removal of the belt cover, bring down the belt cover in the direction opposite to the arrow, and slide it up.

6. LUBRICATION

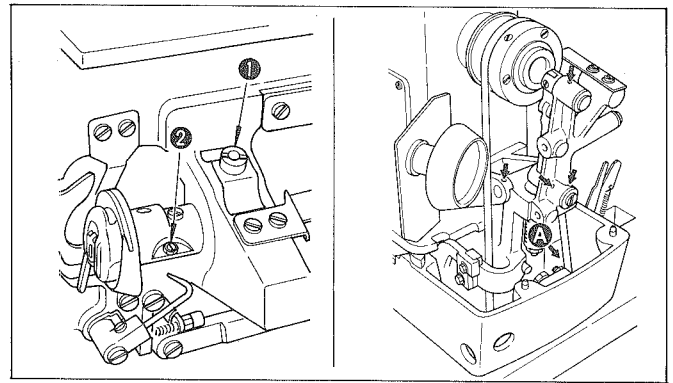
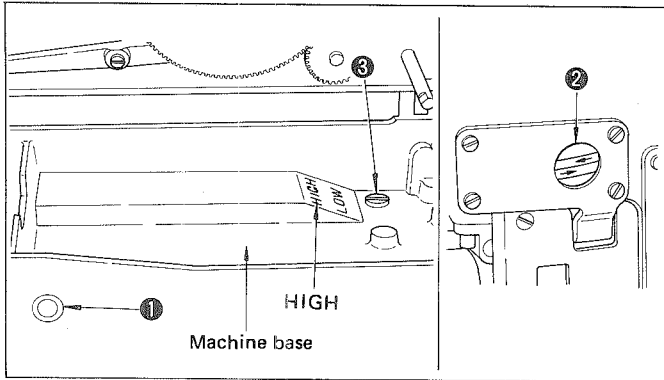

★ Before starting the machine;

1. Fill the oil reservoir of the machine base with JUKI New Defrix Oil No. 1 up to the level indicated by "HIGH".
 2. Supplement the oil when the oil level has lowered below the bottom line of oil gauge ①.
 3. When the machine has been properly lubricated, the oil is seen to run through the pipe from oil sight window ②. (Low speed operation permits easier observation of the lubricating oil.)
- ★ Drain dirty oil by loosening oil drain screw ③, and fill the oil reservoir with fresh oil.

★ Adjusting the lubrication for the sewing hook

Adjust the volume of lubricating oil supplied to the sewing hook by turning oil adjusting screws ① for rough adjustment, and ② for fine adjustment; oil volume is reduced when turning the screws clockwise.

★ Other lubricating points

1. Apply one or two drops of lubricating oil to the arrowed points once a week or every other week.
2. Apply two or three drops of lubricating oil only to ④ point when the machine is newly set up or has been out of use for a long time.

7. HOW TO INSTALL THE NEEDLE

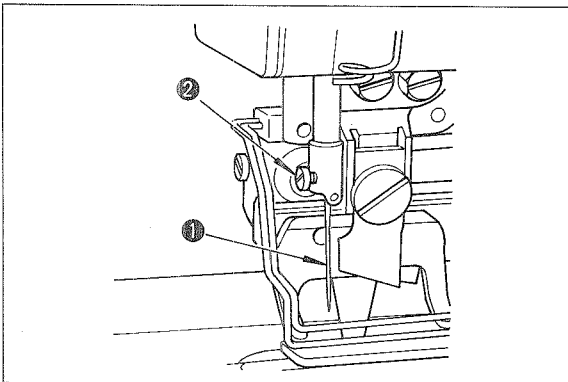

★ Turn off the motor power. Use a DPx5J needle.

1. Loosening needle setscrew ②, hold needle ① with its recessed part facing toward the operator,
2. insert the needle fully into the needle clamping hole, and
3. securely tighten the needle setscrew.

8. INSTALLATION/REMOVAL OF BOBBIN CASE

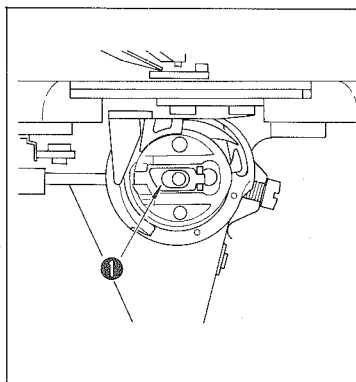

1. Lift up and hold bobbin case latch lever ① between two fingers to remove it from the hook. A bobbin does not fall off the bobbin case while the latch lever is lifted up.
2. For installation of the bobbin case, push the bobbin case into the hook so that it is supported by the hook shaft, and then snap in the latch lever.

10. ATTACHING THE BOBBIN

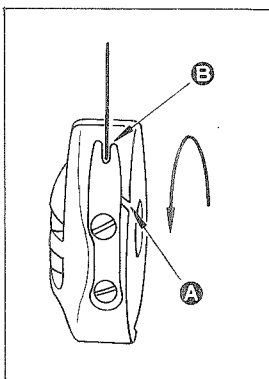

1. Hold and place a bobbin into the bobbin case so that the bobbin is wound counterclockwise.
 2. Passing the thread through thread outlet ④ of the bobbin case, pull the thread, and the thread can be drawn out from thread outlet ⑤, passing under the bobbin winder tension spring.
- ★ Set the bobbin so that it rotates in the arrow direction when the bobbin thread is pulled.

9. WINDING THE BOBBIN

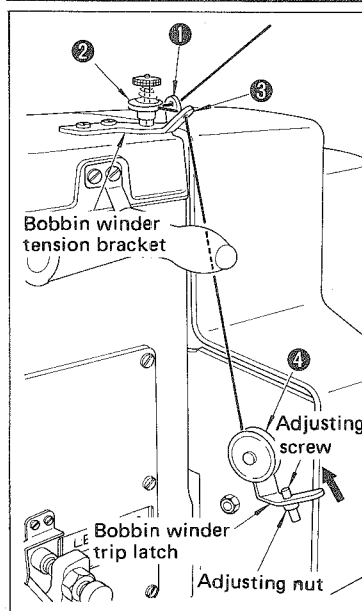

1. Fit a bobbin onto the bobbin winder shaft.
2. Take the thread from the spool and pass it through the guides in the numerical order shown in the figure, and wind the end of the thread several turns around the bobbin.
3. Push the bobbin winder trip latch in the arrow direction, and the bobbin will be wound.
4. Loosening the adjusting nut, perform adjustment by screwing in or out the adjusting screw so that the bobbin is wound about four-fifths full.
5. If the bobbin is wound unevenly, adjust the position of the bobbin winder tension bracket for proper and even winding.

11. THREADING THE NEEDLE-THREAD

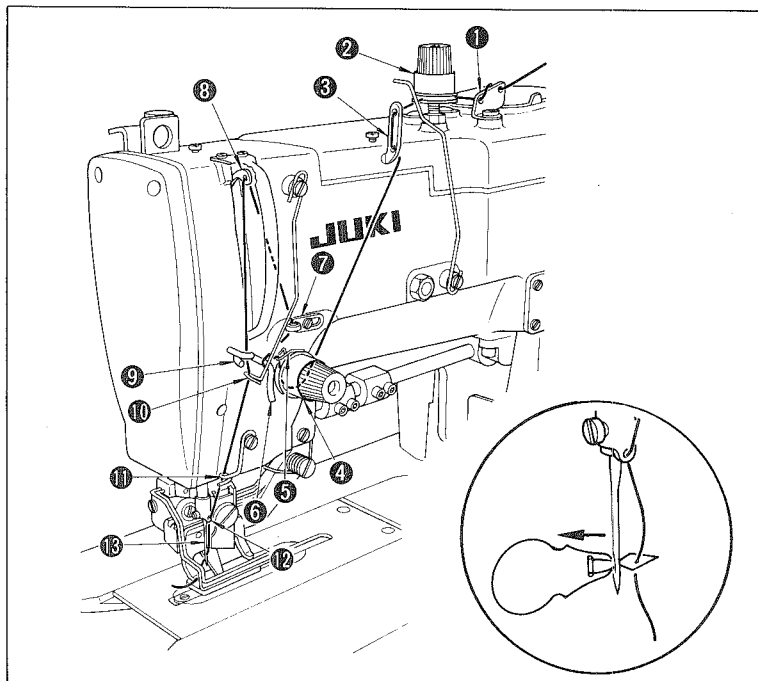

1. Pass the needle thread in the order as shown in the figures.
2. The threading can be done easily by using the needle threader supplied with the machine.

12. REDUCTION OF SEWING SPEED AND EMERGENCY STOP

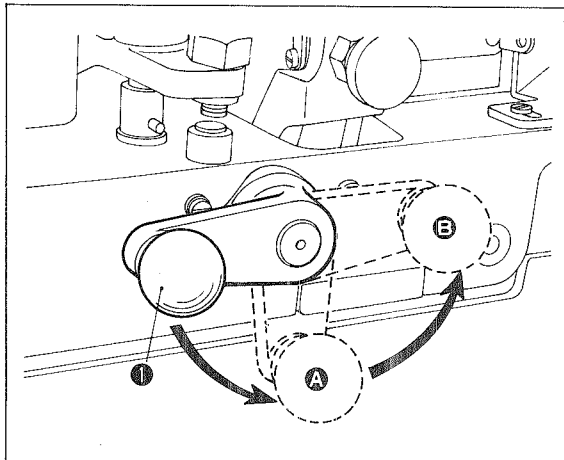

- ★ **Reduction of sewing speed**
 1. Turn hand stop crank ① downwards to position A, and
 2. the machine will be immediately slowed down.
- ★ **Emergency stop**
 1. Turn the hand stop crank downwards to position A, and further upwards to position B and
 2. the machine will stop immediately.

(NOTE) When the hand stop crank do not return, push it down.

13. MANUAL FEED HANDLE

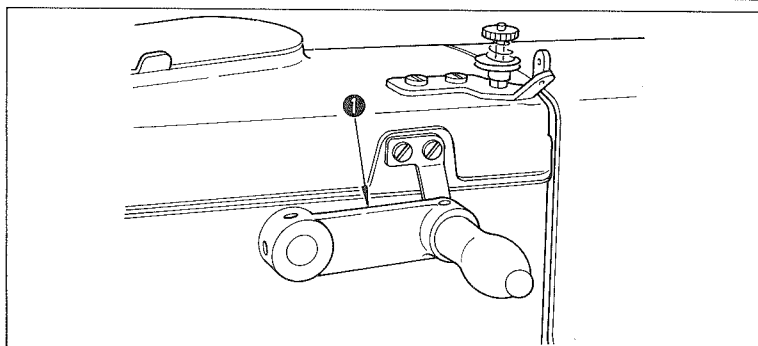

When you want to feed fabric manually after giving an emergency stop or to resume sewing from the point at which thread was broken, rotate manual feed handle ① to operate the cloth feeding mechanism.

(NOTE) Confirm that the needle does not stick in fabric before turning the manual feed handle.

14. HOW TO HOLD THE DESCENDING KNIFE

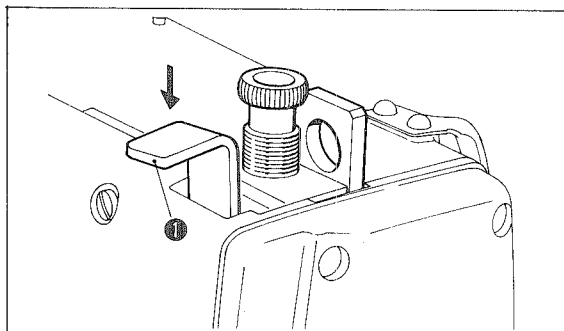

When you do not want to cut fabric after sewing because of thread breakage or some other reasons, keep on pressing down knife stop lever ① lightly until the machine stops. Then the knife will not descend.

15. TYPES OF STITCHES

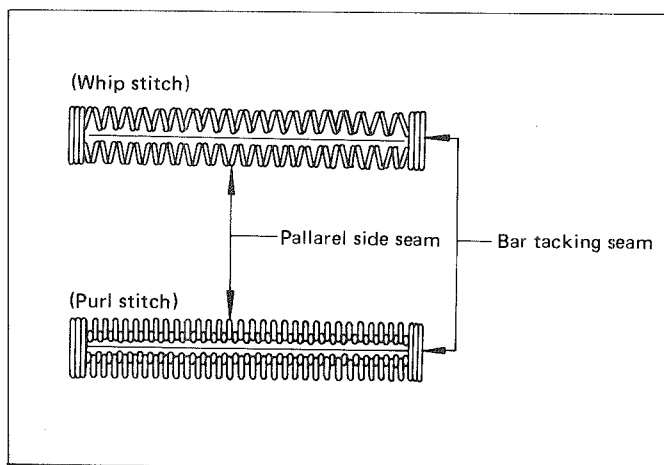

This machine is capable of forming two different types of stitches, namely whip stitch and purl stitch.

(Whip stitch)

The whip stitch is formed in zigzag showing the needle thread only on top of fabric, and the bobbin thread on the bottom.

(Purl stitch)

When applying higher tension to the needle thread to permit it to pass straight through fabric, the purl stitch is formed by the bobbin thread which is pulled over from both sides to the center line.

16. THREAD TENSION

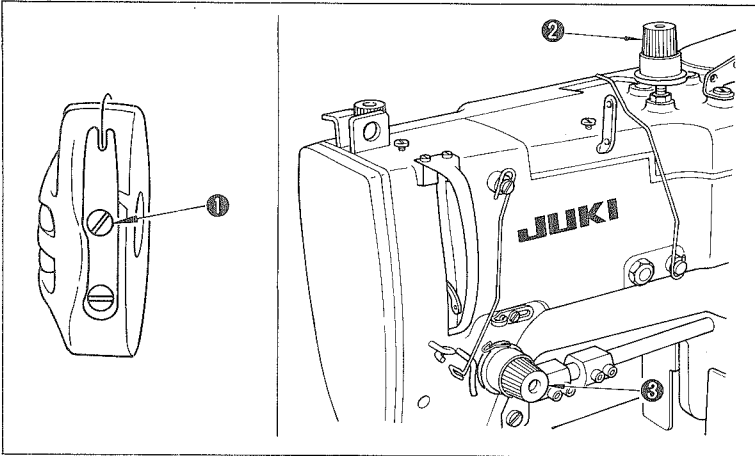

★ Adjusting the thread tension for purl stitch:

1. Adjust the bobbin thread tension to approx. 15 to 20g by adjusting screw ① of the bobbin case.
2. Adjust tension controller No. 1 ② for proper needle thread tension so that the bar-tack part is formed by well-shaped whip stitches. If the tension is too low, bar tacking seam may form thread knots on the rear face of fabric.
3. Adjust tension controller No. 2 ③ for proper tension of the parallel side seams by judging from the stitch formation.

★ Adjusting the thread tension for whip stitch:

1. Adjust the bobbin thread tension to approx. 40 to 50g by adjusting screw ① of the bobbin case.
2. Exchange the adjusting springs of tension controllers No. 1 ② and No. 2 ③ each other (the tension controller No. 2 will have a weak spring).
3. Adjust tension controller No. 2 ③ to prevent raveling off at the end of a seam.
4. The stitches of the parallel sides or bar-tack can be adjusted by tension controller No. 1 ②.

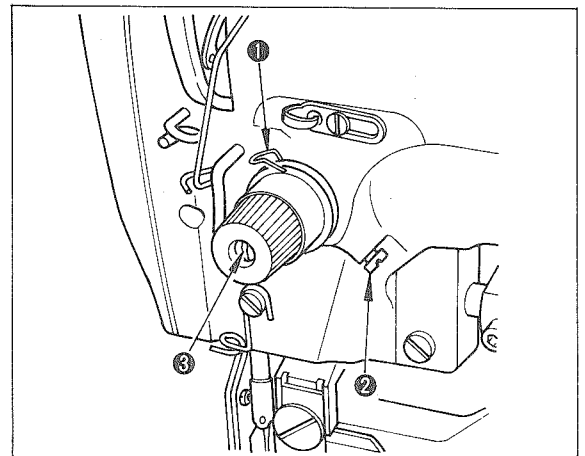

★ Adjusting the thread take-up spring (for purl stitch)

The suitable range of the stroke of thread take-up spring ① is from 6 to 8mm with a starting tension of 20 to 50g.

For adjusting the stroke of the thread take-up spring, loose screw ②, and insert a thin screwdriver into the slit of tension post ③ to turn the tension post.

To adjust the tension of the thread take-up spring, insert a thin screwdriver into the slit of tension post ③ to turn it, with screw ② tightened. The tension of the thread take-up spring increases when the tension post is turned clockwise, and decreases when turned counterclockwise.

17. ADJUSTING THE OVEREDGING LENGTH (BUTTONHOLE LENGTH)

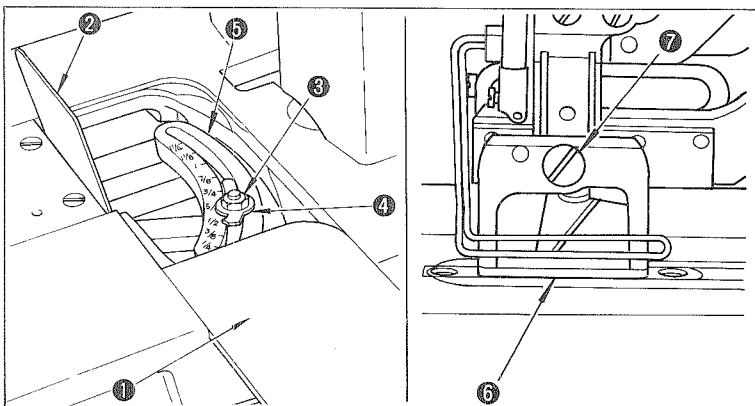

1. Pull out cover ①, and raise cover ②.
2. Loosen nut ③ by the spanner supplied with the machine. Set point ④ to a desired length on scale ⑤ (this length is the same with the knife width), and then retighten nut ③.
3. Through your trial sewing, adjust the overedging length accurately to the extent that the bar tacking seams are not cut by the knife.

★ Changing the work clamp check

Use work clamp check ⑥ having the size nearly the same as that of a buttonhole length.

By removing setscrew ⑦, a work clamp checks can be changed together with a work clamp check holder as a set.

Work clamp check/Work clamp check holder set Part No.	Applicable knife width
B1552-781-0A0	1/4"~3/4"
B1552-782-0A0	1/4"~1"
B1552-783-0A0	1/4"~1-1/4"

18. REPLACING THE KNIFE

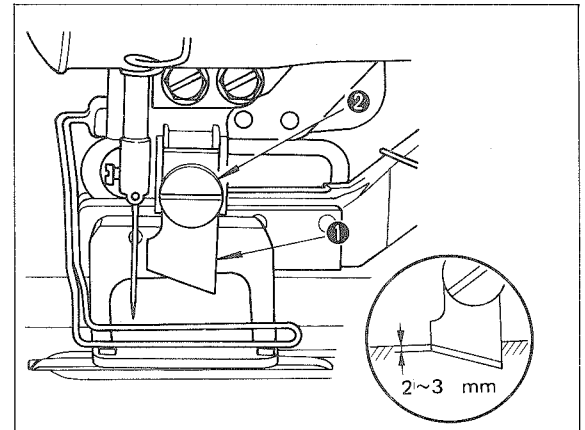

When sharpening or replacing the knife, remove it as follows:

1. Loosen setscrew ②, and remove knife ① together with the washer.
2. Attach the knife to the knife holder so that the higher end of the slanted knife blade comes down 2 to 3mm above the surface of the throat plate when the knife is brought down to the lowest position.

(NOTE): Do not forget to install the washer when retightening the setscrew.

19. ADJUSTING THE OVERDGING WIDTH (STITCH WIDTH AND BAR TACKING WIDTH) AND OVEREDGING REFERENCE POSITION

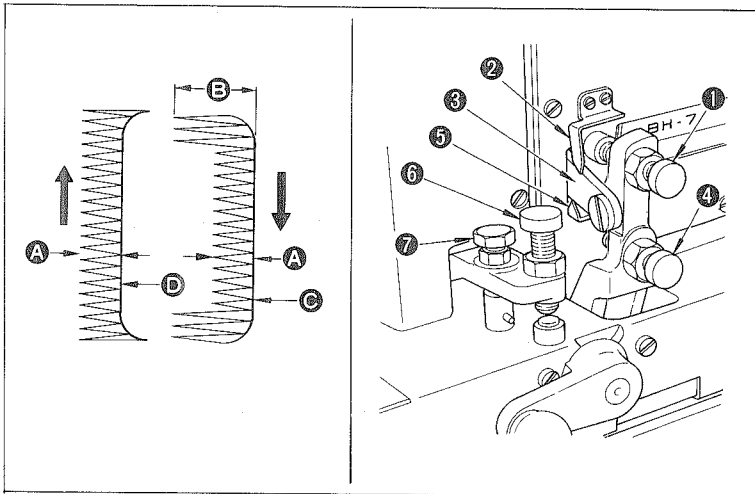

The needle swings from right to left with the right base line established as the reference position.

Perform the adjustment as follows:

1. To adjust stitch width **A**, screw in or out screw **1**, and set pointer **2** to a desired value on scale plate **3**. The actually sewn stitch width will be the half of the set scale value (mm).
2. For adjustment of bar tacking width **B**, screw in or out screw **4**, and set pointer **5** to the value indicated by scale plate pointer **2**, making the bar tacking width twice as large as the stitch width.
3. Adjust the position of right base line **C** by screwing in or out screw **6** so that it is kept away from the cutting line of the knife. As screw **6** is screwed in, the right base line moves to the left.
4. Through your trial sewing, further perform fine adjustment.
5. It is not necessary to adjust the position of left base line **D** since it remains unchanged when the stitch width is changed. However, the left base line should be moved to the left by screwing in screw **7** if it is cut by the knife.

20. CHANGING THE NUMBER OF STITCHES

Symbol	No. of stitches of small gears	No. of stitches of large gears	Symbol	No. of stitches of small gears	No. of stitches of large gears
A	54	345	I	93	200
B	62	300	J	100	190
C	66	285	K	105	180
D	70	268	L	110	170
E	74	252	M	115	160
F	79	238	N	123	152
G	83	225	O	130	145
H	88	212			

★ Spur gears

1. By selecting the spur gears, you can control the number of stitches as shown in the table.
2. Alphabetical marks like A, B, C, etc., and numerals like 123, 152, etc. are both engraved on each spur gear for identification.
3. Use a combination of gears which have the same alphabetical marks.
4. The numeral engraved on the gear installed in the rear position will represent the number of stitched provided by the then combination of spur gears.

(The circled alphabetical symbols in the above table show that the gears are included in the standard accessories. All other gears are optional attachments.)

★ Attaching the spur gears to their shafts

1. Push gear **1** into the shaft so that it is securely fixed by the pin on gear bushing **2** located nearer to an operator.
2. For installing gear **3** on the pin of rear gear bushing **4**, push gear **3** into the shaft while turning it in the arrow direction.

★ Adjusting the low-speed cam position

Loosen setscrews **5**, and adjust the position of low-speed cam **6** to set clearance **A** as shown below:

Number of stitches	Clearance A
93 stitches or less	10 ~ 12 mm
115 stitches or less	5 mm
123 stitches	0

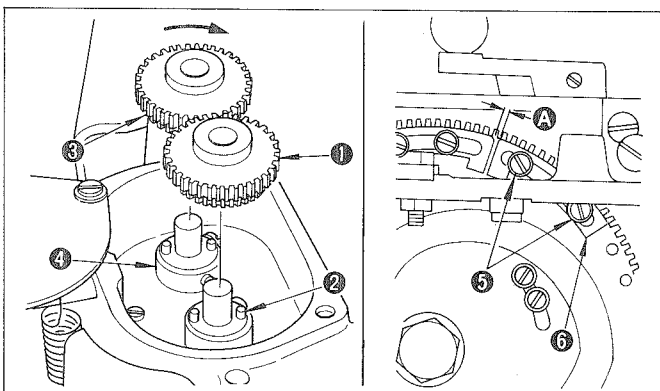

21. ADJUSTING THE PRESSER BAR PRESSURE

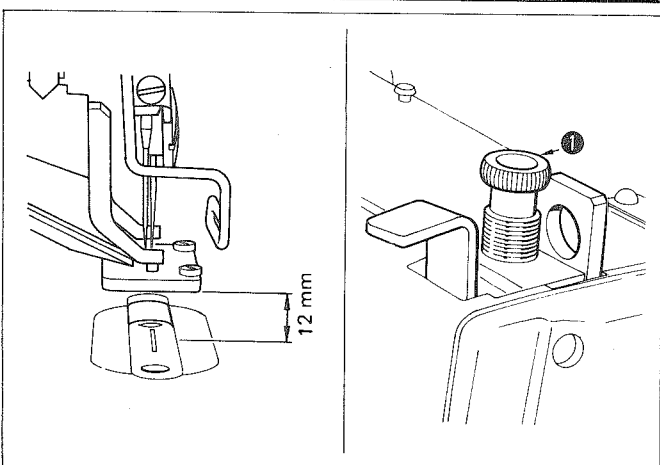

The presser bar goes up 12mm when the pedal is fully stepped down.

To adjust the pressure applied by the presser bar to fabric, turn presser spring regulator **1**. When the pressure is not enough to prevent fabric from puckering, turn regulator **1** clockwise.

22. NEEDLE-TO-HOOK RELATION

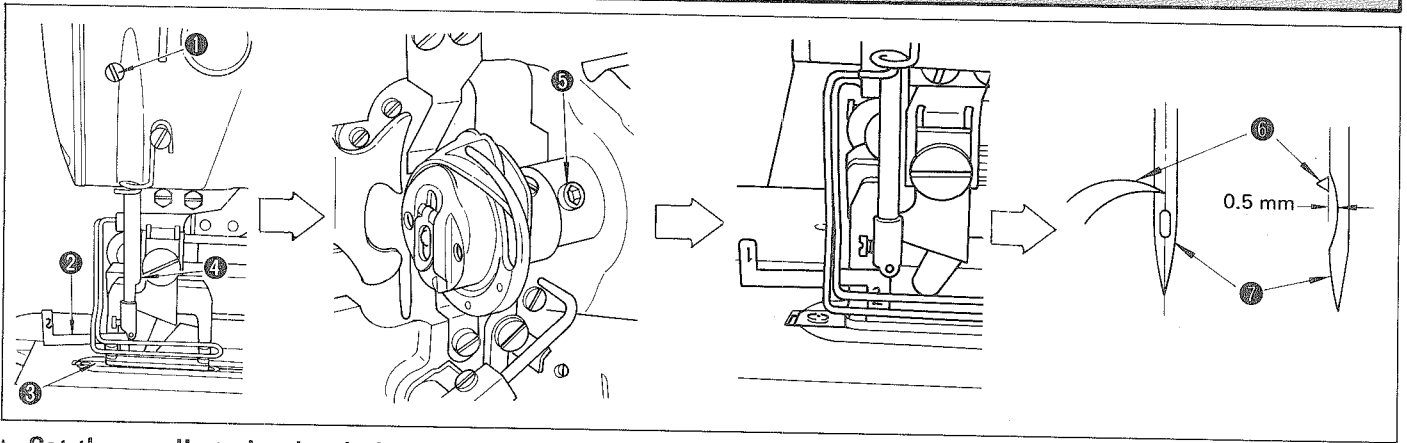

★ Set the needle to hook relation in the following way:

1. Bring down the needle bar to the lowest point when the needle is coming down through the center of the needle hole on the throat plate.

2. Loosen needle bar connection screw (1), and adjust the height of the needle bar.

(Setting the needle bar)

3. Insert the part "1" of timing gauge (2) into the gap between the bottom end of needle bar (4) and throat plate (3).

4. Retighten the needle bar connection screw to adjust the position of the sewing hook.

(Setting the hook)

5. Loosen setscrew (5) of the hook sleeve by the bar spanner supplied with the machine.

6. Rotate the driving pulley in the correct direction until the needle starts to go up from its lowest point.

7. Insert the part "2" of the timing gauge into the gap between the bottom end of the needle bar and the throat plate, where the bottom end of the needle bar touches the top of the part "2" of the timing gauge.

8. Align blade point (6) of the sewing hook with the center of needle (7), and make adjustment so that a clearance of approx. 0.5mm (1/64") is provided between the needle and the blade point of the hook. Then, securely retighten the setscrew of the hook sleeve.

(NOTE): If stitches are skipped, lower the needle bar by approx. 0.5mm (1/64") from the timing gauge "1".

23. ADJUSTMENT THE BOBBIN THREAD WINDER

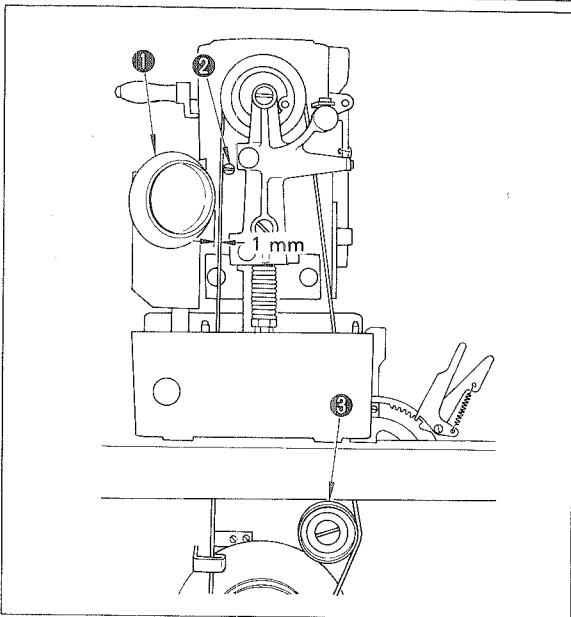

Loosen screw (2) to make adjustment so that the clearance between bobbin thread winder pulley (1) and belt (2) becomes approx. 1mm (33/64") when pulley (1) is apart from the belt.

If, however, the belt touches the pulley, adjust the tension by tension pulley (3) to decrease the deflection of the belt. And if the belt still touches the pulley, increase the clearance to more than 1mm (3/64").

24. ADJUSTING THE SPEED TRANSMITTER

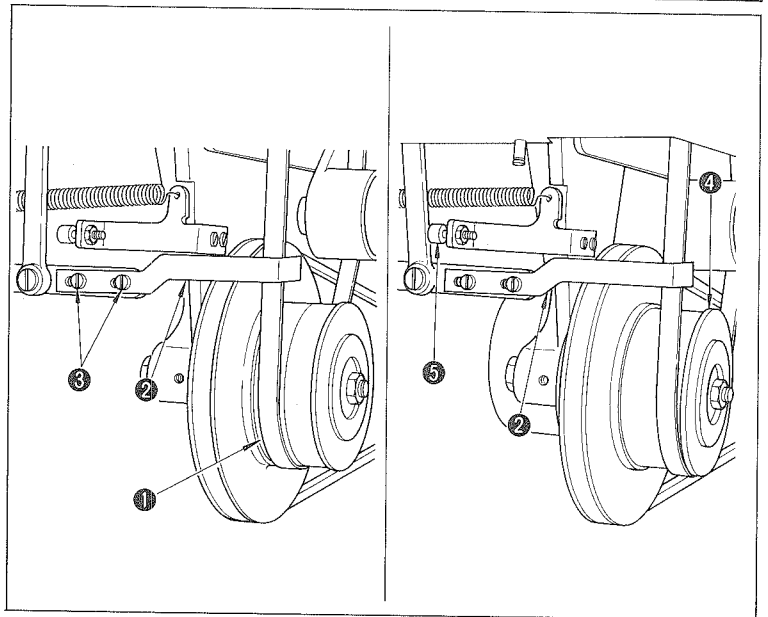

★ Adjustment of the position of the belt shifter

When the hand stop crank is turned down to the low speed position, loosen screw (3) and allow the belt to move onto low-speed pulley (4), moving the position of belt shifter (2).

★ Adjusting the stopper screw

Perform adjustment by stopper screw (5) so that belt shifter (2) does not cause the belt to come off high-speed pulley (4) during high speed operation.

25. ADJUSTMENT OF THE NEEDLE THREAD TRIMMER

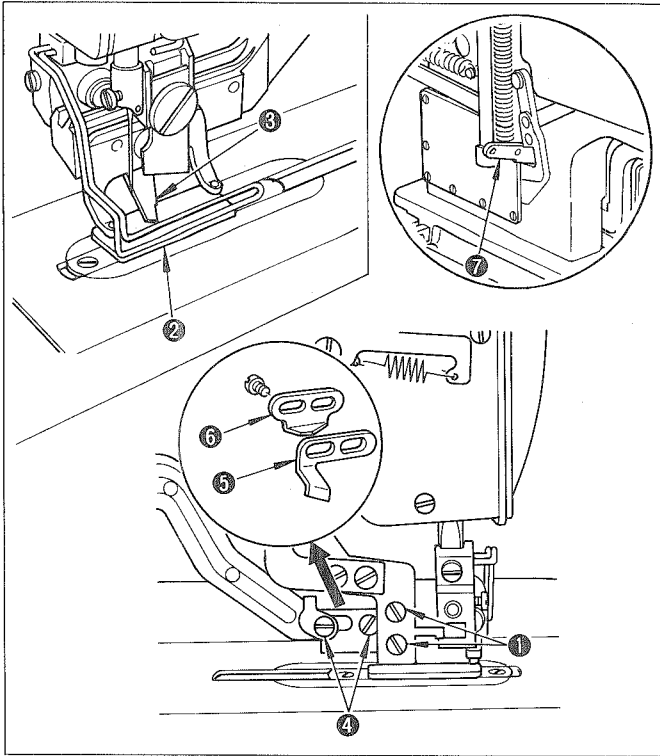

★ Attaching the trimmer

Loosen setscrew ①, and adjust the height of trimmer ②. Set the height of trimmer ③ as low as possible, provided that it does not touch work clamp check ④, in order to minimize the length of remaining thread on the needle after trimming.

★ Closing timing of the needle thread trimmer

Adjust the closing timing of the needle thread trimmer so that the trimmer closes completely when it advances farthest.

To perform the adjustment, loosen screw ④, and move needle thread trimmer driving plate A ⑤ back and forth. When the needle thread trimmer driving plate is moved towards you, the closing timing is delayed with reduced amount of closing.

(NOTE) Confirm that an allowance of 0.3 to 0.5 mm is left between the blades of the trimmer when the trimmer has completely closed.

If there is no such allowance, the trimmer would interfere with the operation of the needle thread trimmer driving plate, preventing smooth movement of lifting lever ⑦.

★ Opening timing of the needle thread trimmer

Adjust the timing of the needle thread trimmer so that the trimmer begins to open gradually at a distance of approx. 2.5 to 3mm ($3/32''$ to $1/8''$) from the start.

To perform the adjustment, loosen screw ④, and move needle thread trimmer driving plate B ⑥ back and forth. As it moves towards you, the trimmer begins to open earlier.

(NOTE): Take care not to cause the already fixed needle thread trimmer driving plate A to get out of position.

26. ADJUSTMENT OF NEEDLE THREAD TRIMMER HOLDER AND LIMITING PLATE

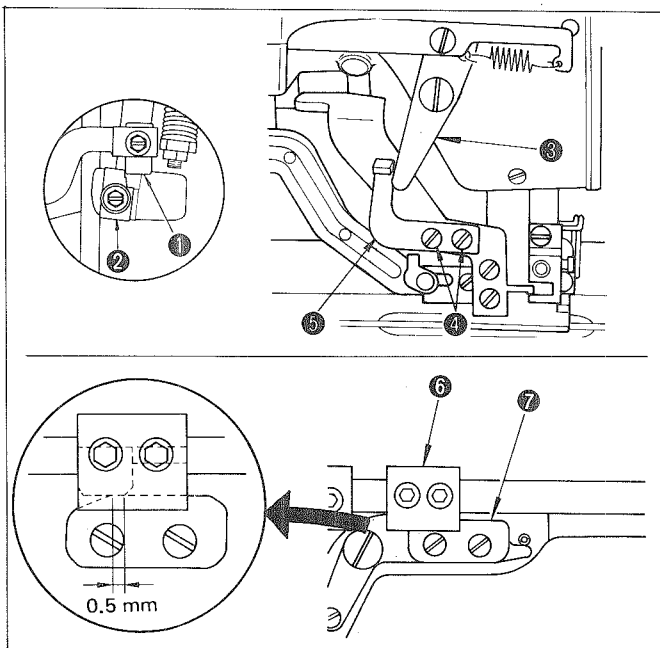

Loosen setscrew ④, and install and adjust limiting plate ⑤ so that it comes in contact with the blocking arm ⑥ at the time of slow start of the machine (when latch B ① is engaged with latch A ②).

Needle thread trimmer holder ⑥ should be installed in such manner that it engages with cam ⑦ by 0.5mm ($1/64''$) when the needle thread trimmer opens.

27. TIMING FOR DROPPING THE KNIFE

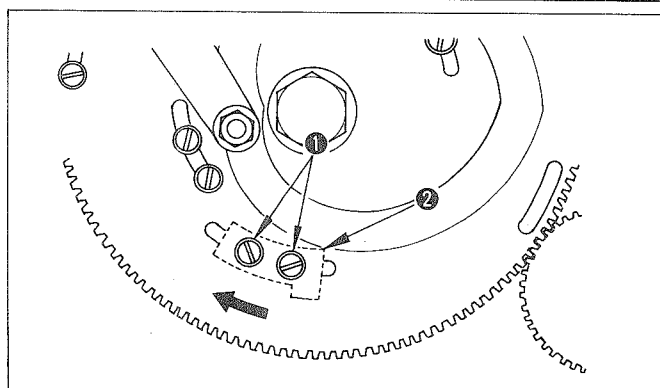

Loosen screws ①, and move knife tripping segment ② in the direction shown by the arrow, and the knife will drop earlier. Adjust it so that the knife drops two to three stitches before the machine stops.

28. TROUBLE, CAUSE, AND REMEDY

Trouble	Cause	Remedy	Page
1. Needle thread is broken.	(1) The tension of the tension controller No. 2 is too tight.	○ Decrease the tension of the tension controller No. 2	5
	(2) The tension or the stroke of the take-up spring is too great.	○ Decrease the tension or the stroke of the take-up spring.	5
	(3) Blade point of sewing hook has burr or scratches.	○ Buff the blade point of the sewing hook, or replat the sewing hook.	7
	(4) Poor timing of the sewing hook.	○ Readjust the sewing hook's timing by the timing gauge.	7
	(5) The thread path has scratches.	○ Buff the thread path by cloth files, etc.	7
	(6) The needle is too thin.	○ Replace by a thick needle.	3
2. Thread slips out of the needle.	(1) The needle thread trimmer opens too early.	○ Move back the needle thread trimmer driving plate B.	8
	(2) The needle thread trimmer opens when the work clamp check is coming down.	○ Move back the needle thread trimmer driving plate B.	8
	(3) The whip stitch is not formed at the start of sewing.	○ Decrease the tension of the tension controller No. 1.	5
	(4) Wrong threading.	○ Perform correct threading.	4
3. Wobbling stitches are formed in the overedging seams.	(1) The tension disc No. 2 is too loose.	○ Increase the tension of the tension disc No.2.	5
	(2) The tension and stroke of the take-up spring is not enough.	○ Readjust the take-up spring.	5
	(3) Bobbin thread tension is too high.	○ Decrease the bobbin thread tension (15 to 20g for purl stitches).	5
4. Wobbling stitches are formed at the start of sewing.	(1) The tension disc No. 1 is too loose.	○ Increase the tension of the tension disc No. 1 (15 to 30g).	5
	(2) The position of the needle thread trimmer is too high.	○ Lower the trimmer as low as possible, provided it does not come in contact with the work clamp check.	8
	(3) The stroke of the take-up spring is too great.	○ Decrease the stroke of the take-up spring, and increase the spring pressure.	5
5. The needle thread at the first bar tacking comes out and lumps on the bottom of cloth.	(1) The tension disc No. 1 is too loose.	○ Increase the tension of the tension disc No. 1.	5
	(2) The bobbin thread tension is too high.	○ Decrease the bobbin thread tension (15 to 20g).	5
6. Stitches float over cloth.	(1) Bobbin thread tension is not enough.	○ Increase the bobbin thread tension.	5
	(2) Bobbin thread slips out of the thread path on the bobbin case.	○ Properly thread the bobbin case.	3
7. Stitches are skipped.	(1) The work clamp check is too large for the buttonhole.	○ Change the work clamp check with a smaller one.	5
	(2) The cloth is made of light-weight materials.	○ Delay the timing of the needle and the sewing hook. (Lower the needle bar by approx. 0.5mm (1/2"))	7

29. STITCHING TROUBLES CAUSED BY OTHER REASONS

Trouble	Cause	Remedy	Page
1. Starting pedal does not work. (The work clamp arm is not lifted up fully.)	(1) Needle plate, needle plate base or bobbin thread trimmer is clogged with fibrous dust. (2) The needle thread trimmer is interfered by the work clamp check or the trimmer driving plate.	○ Tilt the machine head and clean them up. ○ Readjust the installation of the trimmer, or the position of the trimmer driving plate.	8
2. Machine does not reach the high speed even when the pedal is stepped down fully.	(1) The hand stop crank is not in the correct position. (2) The belt shifter of the speed transmitter has not changed to the high speed pulley.	○ Correct the position of the hand stop crank. ○ Lubricate the shifter driving pin.	4
3. A loud noise is produced with a stop-motion, or sewing speed does not lower at the end of sewing.	(1) Improper setting of the low speed cam for small numbers of stitches. (2) The flat belt is too loose. (3) The low speed V belt is too loose.	○ Readjust the setting of the low speed cam. ○ Increase the belt tension by the tension pulley. ○ Increase the tension of the V belt by the motor.	6 2 1
4. Stop-motion is not smooth.	(1) Stop-motion lever needs lubrication. (2) The belt shifter of the speed transmitter has not changed to the low speed pulley.	○ Lubricate the stop-motion lever. ○ Readjust the position of the belt shifter.	3 7
5. The machine does not lubricate.	(1) Oil level in the oil reservoir is too low. (2) Oil is not circulated.	○ Fill the lubricating oil up to "HIGH" mark. ○ Apply oil to the oil return felts.	3 3
6. Knife is dropped during high speed rotation.	(1) Position of the knife tripping segment is not correct. (2) The setting of the low speed cam for numbers of stitches is not correct.	○ Adjust the position of the driving cam so that the knife is dropped down at a delayed timing. ○ Correct the setting of the low speed cam.	8 6
7. Knife is dropped even if the needle thread is broken.	(1) The machine is threaded incorrectly.	○ Correct the threading.	4
8. Needle is broken.	(1) The needle is bent. (2) The needle and the hook blade touch with each other. (3) Needle thread trimmer hits the needle when opening its blades.	○ Replace the needle. ○ Readjust the positions of the needle and the sewing hook. ○ Readjust the position of the trimmer. ○ Adjust so that the limiting plate and the blocking arm touch each other at the time of starting.	3 7 8 8

30. SPECIFICATIONS

	LBH-781	LBH-782	LBH-783	LBH-784
Application	Buttonholing for ordinary cloth, knit, etc.			
Sewing speed	Max. 3,600 s.p.m.			
Buttonhole length	6.4 ~ 19.0 mm (1/4" ~ 3/4")	6.4 ~ 25.4 mm (1/4" ~ 1")	6.4 ~ 31.7 mm (1/4" ~ 1-1/4")	12.7 ~ 38.0 mm (1/2" ~ 1-1/2")
Bar-tack width	2.5 ~ 4.0 mm (3/32" ~ 5/32")	2.5 ~ 5.0 mm (3/32" ~ 3/16")		
Needle	DP x 5J #11 ~ #14			
Presser lift	12 mm (15/32")			
Lubricating oil	JUKI New Defrix Oil No. 1			

JUKI

JUKI CORPORATION

HEAD OFFICE
8-2-1 KOKURYO-CHO,
CHOFU-CITY, TOKYO 182, JAPAN

BUSINESS OFFICE
1-23-3 KABUKI-CHO
SHINJUKU-KU, TOKYO 160, JAPAN

PHONE : 03(3205)1188, 1189, 1190

FAX : 03(3203)8260, (3205)9131

TELEX : J22967, 232-2301

To order or for further information, please contact :

Please do not hesitate to contact our distributors or agents in your area for further informations when necessary.
* The description covered in this instruction manual is subject to change for improvement of the commodity without notice.
* This instruction manual is edited and printed in accordance with the product specifications as of September, 1991.