

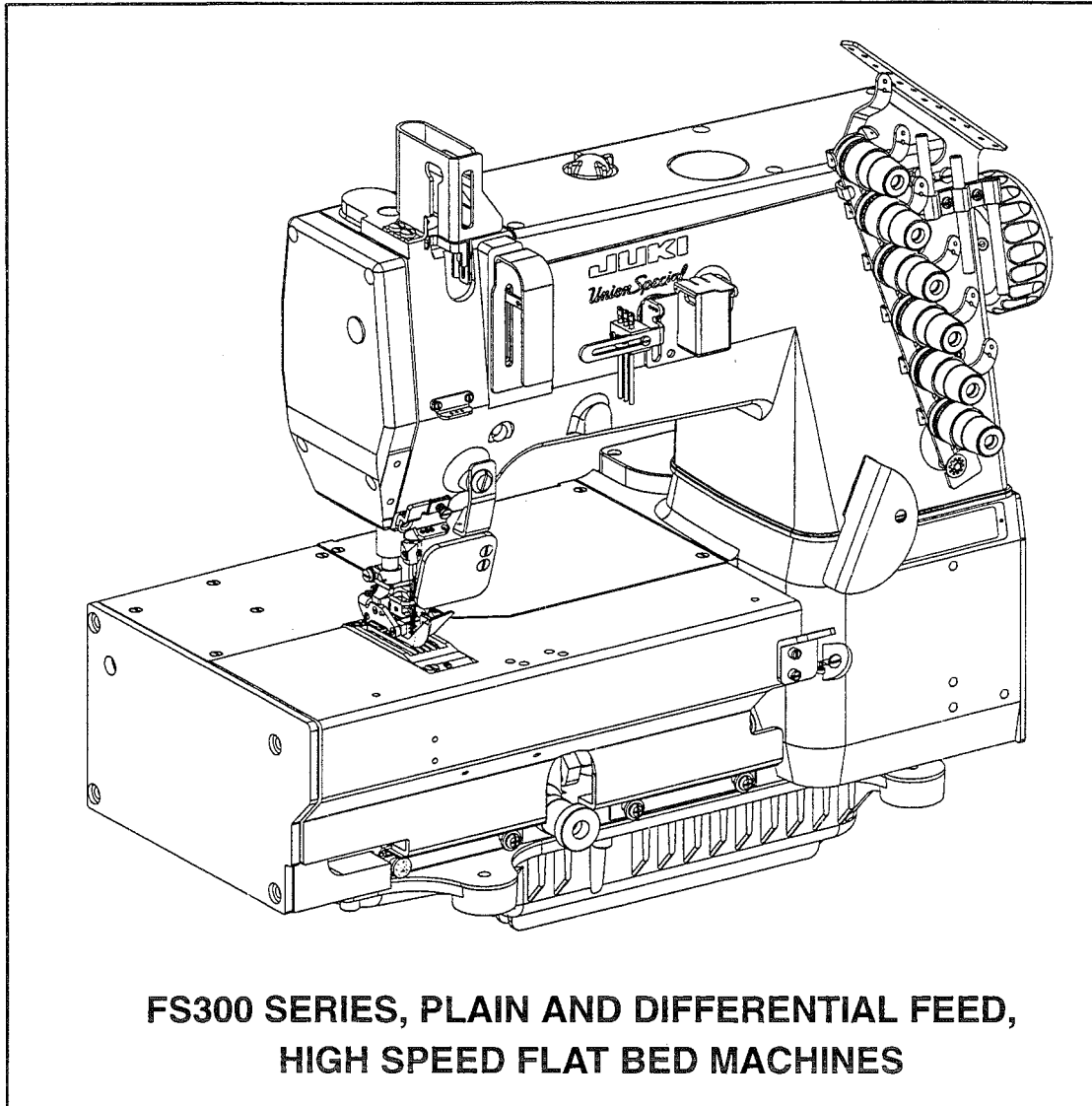

# *Union Special*

INDUSTRIAL SEWING EQUIPMENT

## OPERATOR / ILLUSTRATED PARTS MANUAL



**MANUAL NO. PT9808  
FOR STYLES**

**FS311L51  
FS311L52  
FS311L53**

# Manual No. PT9808 Illustrated Parts List for FS300 Series Machines

---

---

Second Edition Copyright 1999

By

Union Special Corporation Rights Reserved In All Countries

Printed in U.S.A. Aug. 1999

---

---

## PREFACE

This parts manual has been prepared to assist you in locating individual parts or assemblies on FS300 Series machines. It can be used in conjunction with Union Special Engineer's Manual EN9424.

It is the desire of Union Special that each machine run at its optimum performance. Parts listed in this manual are designed specifically for your machine and are manufactured with utmost precision to assure long lasting service.

This manual has been comprised on the basis of available information. Changes in design and/or improvements may incorporate a slight modification of configuration in illustrations or part numbers.

On the following pages are illustrations and terminology used in describing the parts used on FS300 Series machines.



## IDENTIFICATION OF MACHINES

Each UNION SPECIAL machine is identified by a style number, which is stamped into the style plate affixed to the middle of the machine under the tension assembly. The serial number is stamped into the serial number plate affixed to the right rear base of the machine.

### CLASS DESCRIPTION

Precision high speed, single needle, plain or differential feed flat bed machines. Totally enclosed feed and looper drive mechanism, automatic forced feed lubrication system with easily replaceable filter. Main feed has thumbscrew adjustment and differential feed has lever adjustment and independently driven rear needle guard.

### STYLE OF MACHINES

- FS311L51-2H64 / 72 DOUBLE LAP SEAM. Two needle, plain feed, high capacity with "Compact tractor" type presser foot. Sewing parts designed for chaining between pieces. For attaching the risers to jeans, bibs to overalls and piecing sleeves on denim jackets. Recommended needle 128 GAS sizes 150/060 - Stitch range 7-14 S.P.I.. Maximum speed 6000 R.P.M..
- FS311L51-2H64 / 72CC2 DOUBLE LAP SEAM. Same as style FS311L51-2H64, FS311L51-2H72, except with Power "Air Klipp" Chain Cutter.
- FS311L52-2H64 / 72 DOUBLE LAP SEAM. Two needle, plain feed, high capacity with "tractor" type presser foot and flat sewing parts. Throat plate has chaining land - Typical Application - For attaching the risers to jeans, bibs to overalls and piecing sleeves on denim jackets. Seam Specifications 401LSc-2. Recommended needle 128 GAS sizes 150/060 - Stitch range 7-10 S.P.I.. Maximum recommended speed 6000 R.P.M..
- FS311L52-2H64 / 72CC2 DOUBLE LAP SEAM. Same as style FS311L52-2H64, FS311L52-2H72, except with Power "Air Klipp" Chain Cutter.
- FS311L52-3H32 / 36 DOUBLE LAP SEAM. Same as style FS311L52-2H64, FS311L52-2H72, except 3 needle.
- FS311L52-3H32 / 36 CC2 DOUBLE LAP SEAM. Same as style FS311L52-3H32, FS311L52-3H36 except with Power "Air Klipp" Chain Cutter.
- FS311L53-3H32 / 36 DOUBLE LAP SEAM. (Stepped Parts) Three needle, plain feed with "tractor" type presser foot. Sewing parts have .070 (1.75mm) step to right of needles and designed for chaining between pieces. For seat seaming operations on jeans, overalls and denim jackets. Seam Specifications 401LSc-3. Recommended needle 128 GAS sizes 150/060 - Stitch range 7-10 S.P.I.. Maximum recommended speed 6000 R.P.M..
- FS311L53-3H32 / 36 CC2 DOUBLE LAP SEAM. Same as style FS311L53-3H32, FS311L53-3H36 except with Power "Air Klipp" Chain Cutter.



## ILLUSTRATIONS

This manual has been arranged to simplify ordering repair parts. Exploded views of various sections of the mechanism are shown so that the parts may be seen in their actual position in the machine. On the page opposite the illustration will be found a listing of the parts with their part numbers, description and the number of pieces required in the particular view being shown.

Numbers in the first column are reference numbers only, and merely indicate the position of the part in the illustration. The reference number should never be used in ordering parts. Always use the part number listed in the second column.

Component parts of sub-assemblies which can be furnished for repairs are indicated by indenting their descriptions under the description of the main sub-assembly. As an example refer to the following text.

5.	50366B	Needle Thread Strike-Off Assembly .....	1
6.	50358V	Needle Thread Strike-Off .....	1
7.	50370F	Thread Strike-Off Component .....	1
8.	SS7060310SP	Screw, for plate strike-off .....	1

When a part is common to all machines covered in this manual, no specific usage will be mentioned in the description. However, when the parts for the various machines are not the same, the specific usage will be mentioned in the description and, if necessary, the difference will be shown in the illustration.

\*Ref. No. showing no Part No. is for location only. Part is not for sale separately.

A numerical index of all the parts shown in this manual is located at the back. This will facilitate locating the illustration and description when only a part number is known.

## IDENTIFYING PARTS

Where construction permits, each part is stamped with its part number. On some of the smaller parts and on those where construction does not permit, an identification letter is stamped in to distinguish the part from similar ones.

PLEASE NOTE: Part numbers represent the same part, regardless of which manual they appear. On all orders please include part number, name and style of machine for which the part was ordered.

For optimum performance use only genuine Union Special replacement parts.

## NEEDLES

Each needle has both a type and size number. The type number denotes the kind of shank, point, length, groove, finish and other details. The size number, stamped on the needle shank, denotes the largest diameter of the blade measured between the shank and the eye. Collectively, the type number and size number represent the complete symbol which is given on the label of all needles packed and sold by Union Special.

<u>TYPE</u>	<u>DESCRIPTION</u>
128 GAS	Short, double groove, struck groove, ball eye, spotted, round point, chromium plated- Sizes available 080/032, 090/036, 100/040, 110/044, 125/049, 150/060.

When changing the needle, make sure it is fully inserted in the needle holder before the screw is tightened.

When ordering needles, please use the complete type and size numbers as printed on the package to ensure prompt and accurate processing of your order. A complete order should read as follows: "100 needles, type 128 GAS, size 150/060".



## SAFETY RULES

1. Before putting the machines described in this manual into service, carefully read the instructions. The starting of each machine is only permitted after taking notice of the instructions and by qualified operators.

**IMPORTANT!** Before putting the machine into service, also read the safety rules and instructions from the motor supplier.

2. Observe the national safety rules valid for your country.
3. The sewing machines described in this instruction manual are prohibited from being put into service until it has been ascertained that the sewing units which these sewing machines will be built into, have conformed with the EC Council Directives (89/392/EEC, Annex II B).

Each machine is only allowed to be used as foreseen. The foreseen use of the particular machine is described in paragraph "STYLES OF MACHINES" of this instruction manual. Another use, going beyond the description, is not as foreseen.

4. All safety devices must be in position when the machine is ready for work or in operation. Operation of the machine without the appertaining safety devices is prohibited.
5. Wear safety glasses.
6. In case of machine conversions and changes all valid safety rules must be considered. Conversions and changes are made at your own risk.
7. The warning hints in the instructions are marked with one of these two symbols:



8. When doing the following the machine has to be disconnected from the power supply by turning off the main switch or by pulling out the main plug:
  - 8.1 When threading needle(s), looper, spreader etc.
  - 8.2 When replacing any parts such as needle(s), presser foot, throat plate, looper, spreader, feed dog, needle guard, folder, fabric guide etc.
  - 8.3 When leaving the workplace and when the workplace is unattended.
  - 8.4 When doing maintenance work.
  - 8.5 When using clutch motors without actuation lock, wait until the motor is stopped totally.
9. Maintenance, repair and conversion work (see item 8) must be done only by trained technicians or special skilled personnel under consideration of the instructions.
10. Any work on the electrical equipment must be done by an electrician or under direction and supervision of special skilled personnel.
11. Work on parts and equipment under electrical power is not permitted. Permissible exceptions are described in the applicable sections of standard sheet DIN VDE 0105.
12. Before doing maintenance and repair work on the pneumatic equipment, the machine has to be disconnected from the compressed air supply. In case of existing residual air pressure, after disconnecting from compressed air supply (i.e. pneumatic equipment with air tank), the pressure has to be removed by bleeding.

# FS300 SERIES BUILDING BLOCK STYLE DESIGNATION SYSTEM

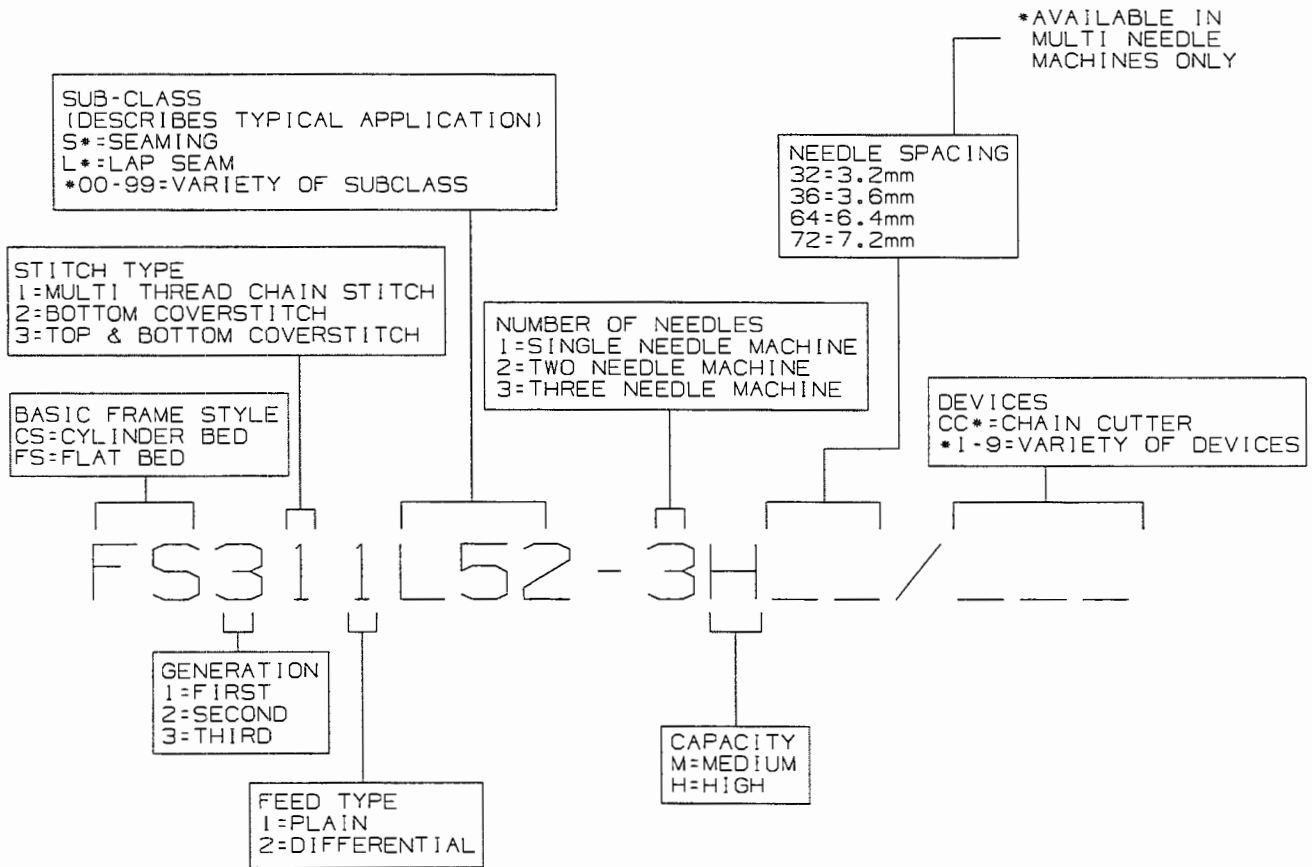

CAUTION AREAS:

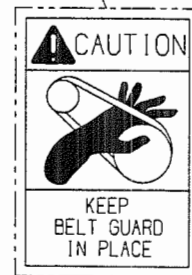
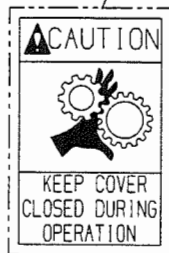
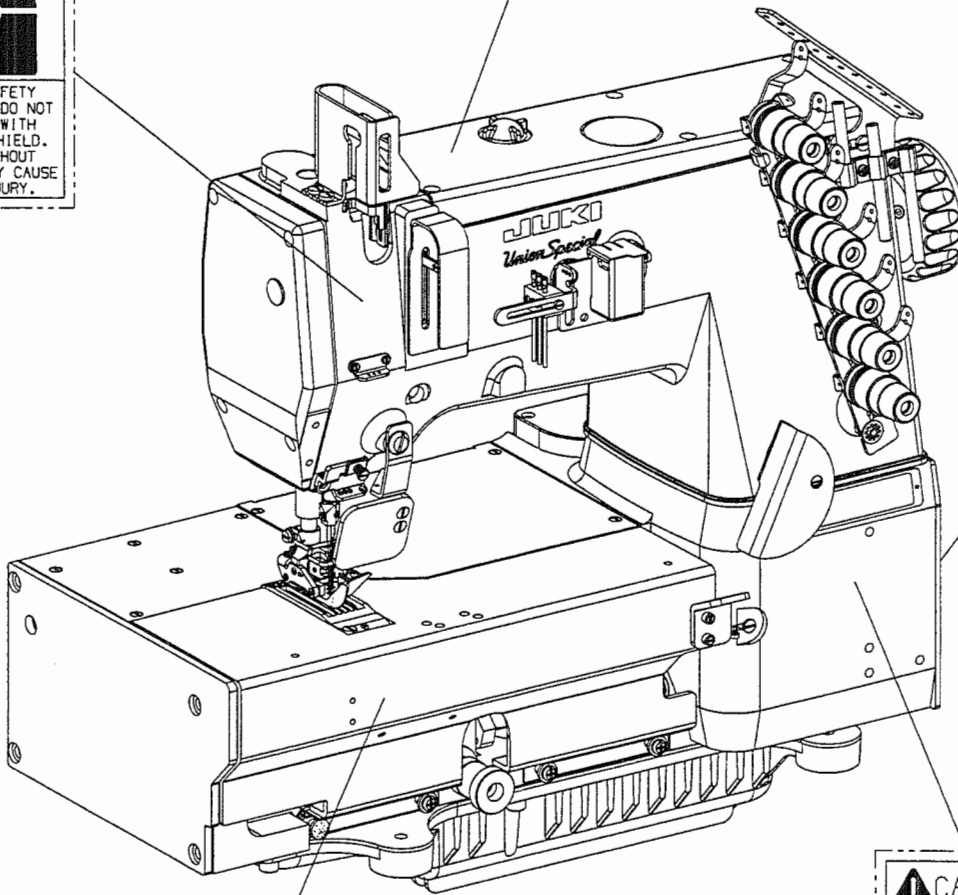
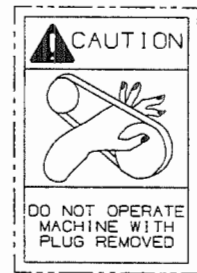

### OPERATOR'S DAILY CHECK LIST:

The following should be checked daily and cleaned as required when it applies to your Union Special machine:

- Oil flow
  - Oil level
  - Lint area (clean with compressed air or brush)
  - Needle bar bushings
  - Under feed dogs & throat plates
  - In knives
  - In thread control eyelets
  - Cooling airways
  - In the machine
  - In the motor
  - In the cooling package
- (package is an extra send charge)

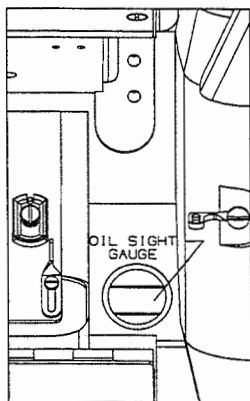

1. The oil level in the sight gauge should be between the two red lines when the machine is at rest. If not, fill with Union Special Specification 175 oil, (Union Special Part No. 28604R).

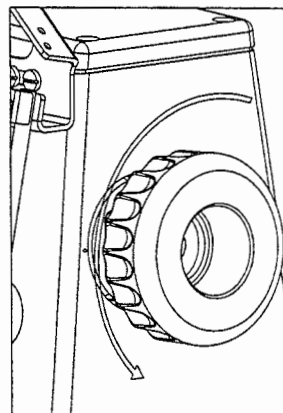

2. The correct rotating direction of the handwheel is counterclockwise, as viewed from the handwheel's side. NEVER run the machine in reverse direction.

### OPERATING CAUTIONS:

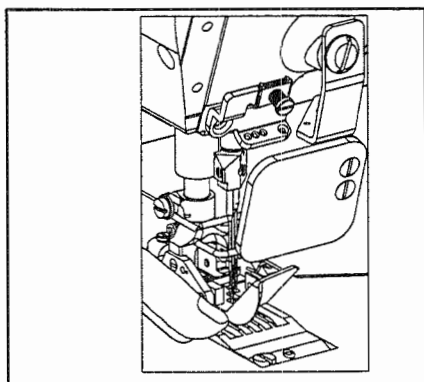

1. Do not put your hand under the needles when turning on the power switch or at any time.

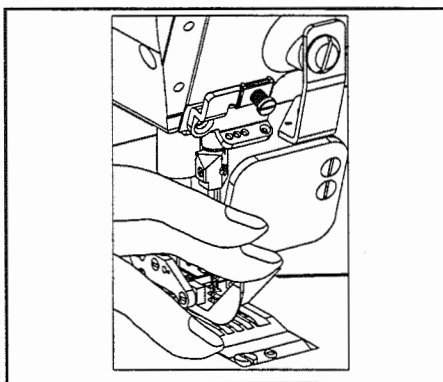

2. Do not put your hand into the sewing area while the machine is running.

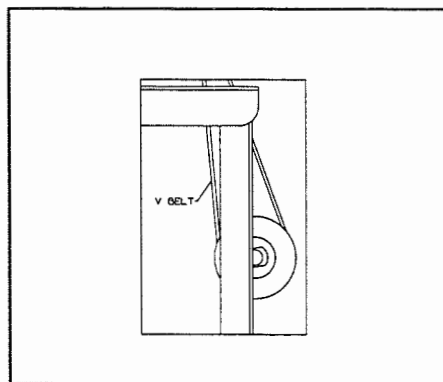

3. Turn off the power switch and make sure the clutch motor is at rest before removing the V belt.



## OPERATING CAUTIONS (CONT.):



4. During operation, do not allow head, hands or any instrument, tool etc. near handwheel, V belt and motor.
  5. Do not operate your machine without the proper belt guard, sewing guards or any other protectors that have been provided. Doing so is very dangerous.
  6. Before inspecting, adjusting, cleaning, threading the head or replacing needles, turn OFF the power switch. Make sure the flywheel on the motor has stopped, it will be kept running by inertia after turning OFF the power switch. DO NOT depress the foot pedal while the machine is running or it will cause the machine to rotate abruptly.
  7. Turn OFF the power switch when you leave your machine or in case of a power failure.
  8. Do not wipe the machine surface with lacquer thinner.
- 

## OPERATING THE PEDALS:

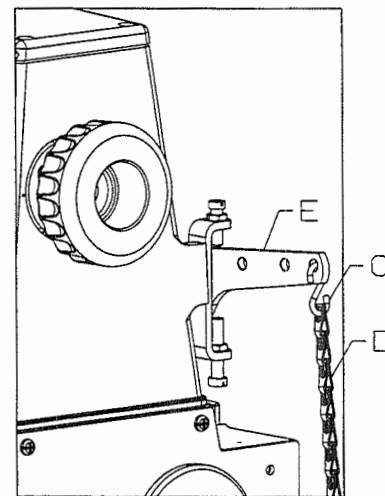
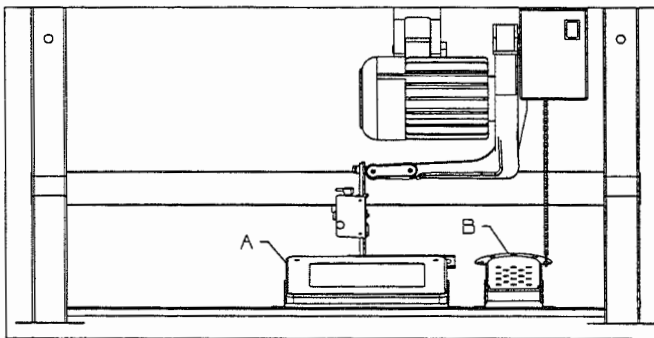

1. Locate the center of drive treadle (A) to be in line with the needles.
2. Locate presser lifter pedal (B) for operator comfort.
3. Use S-shaped hook (C) to connect presser lifter pedal chain (D) to presser lifting lever (E).

## LUBRICATION:

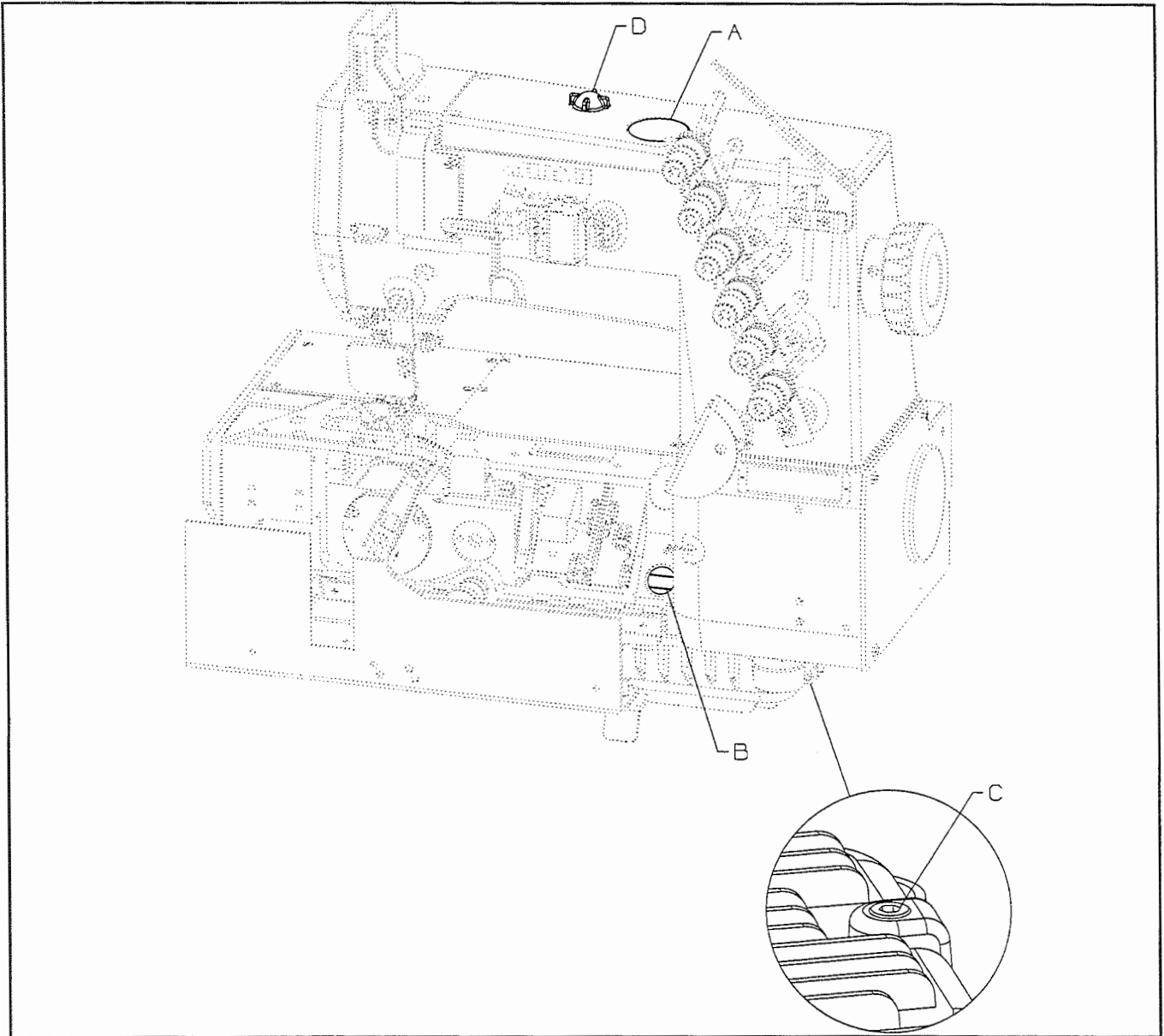

The oil should be between the two red lines in sight gauge (B) when the machine is at rest.

1. If oil is required remove oil cap (A).
2. Fill between lines (B) with Union Special Specification 175 oil (Union Special Part No. 28604R).



**CAUTION!** Do not exceed the upper red marker line. Excessive oil in the machine will result in oil leakage and possible overheating.

3. To drain oil reservoir, remove oil drain cap (C) on the underside of the machine.
4. To ensure oil flow through machine, check oil flow window (D).

## THREADING THE MACHINE:



Turn off main power switch before threading! When using clutch motors without actuation lock wait until the motor has completely stopped.

Thread the machine according to the following threading illustrations.

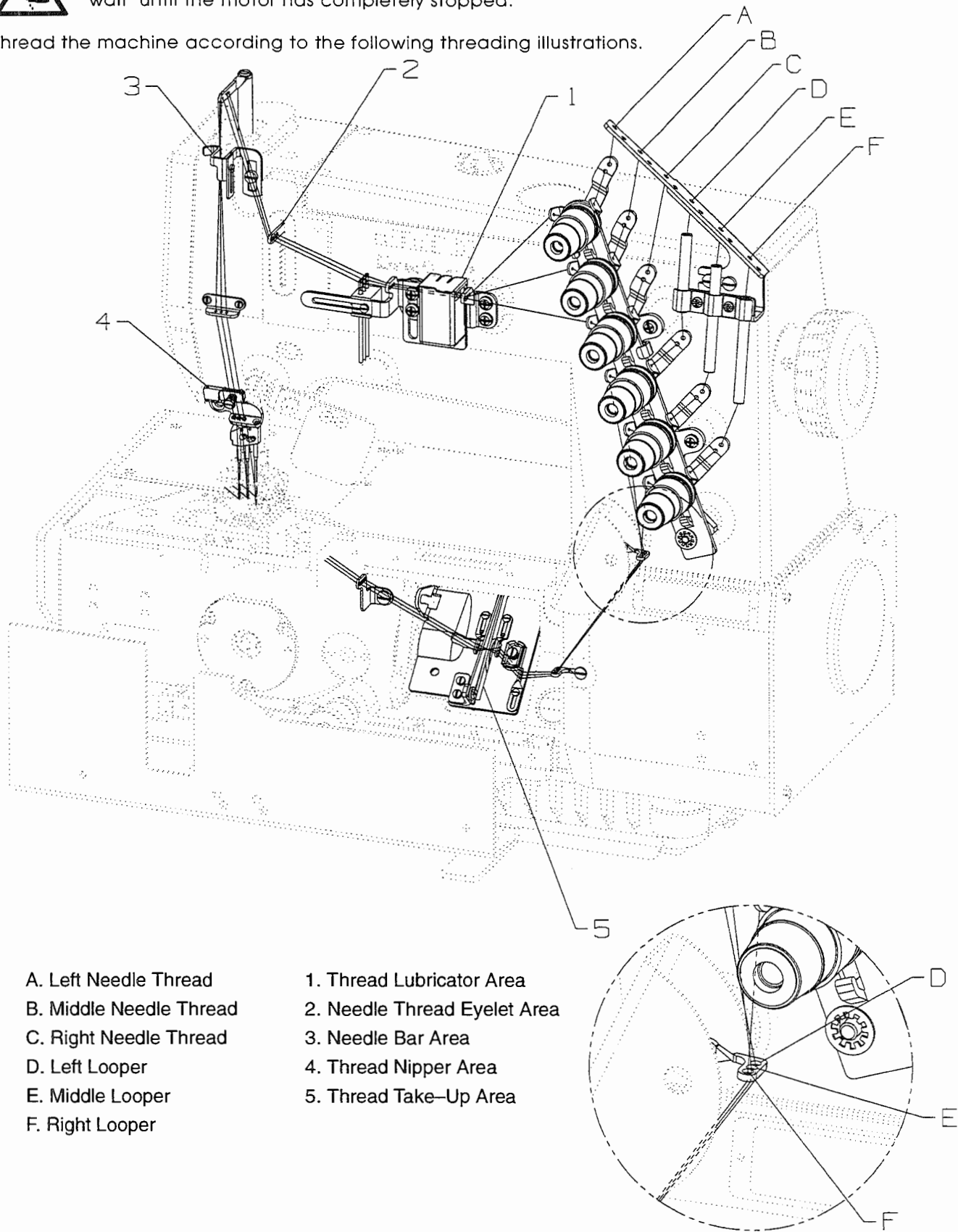

- A. Left Needle Thread
- B. Middle Needle Thread
- C. Right Needle Thread
- D. Left Looper
- E. Middle Looper
- F. Right Looper

- 1. Thread Lubricator Area
- 2. Needle Thread Eyelet Area
- 3. Needle Bar Area
- 4. Thread Nipper Area
- 5. Thread Take-Up Area



THREADING THE MACHINE (CONT.):

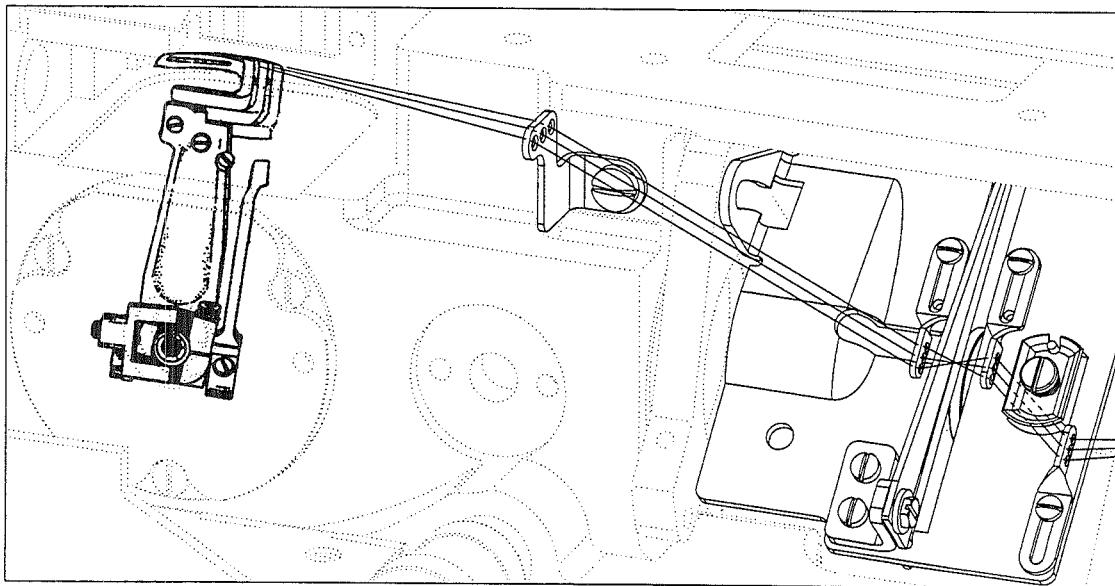
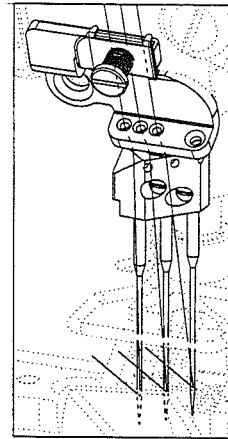
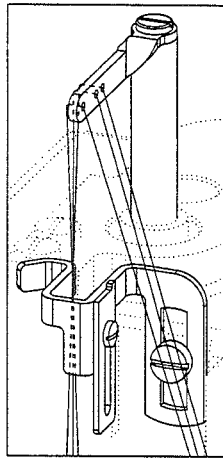
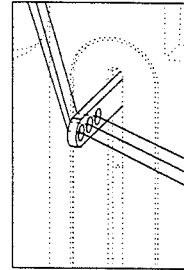
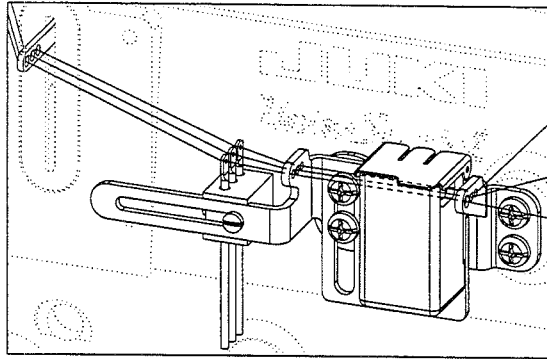

## THREADING THE MACHINE (CONT.):

When the needle thread lubricator is used:

1. Saturate felt (A).
2. Pass thread over felt.

When the needle thread lubricator is not used:

1. Remove felt (A).

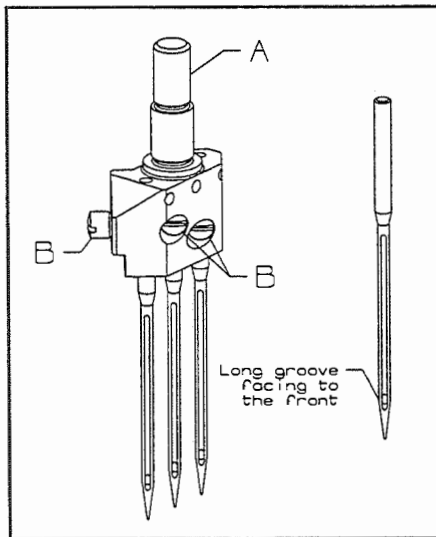
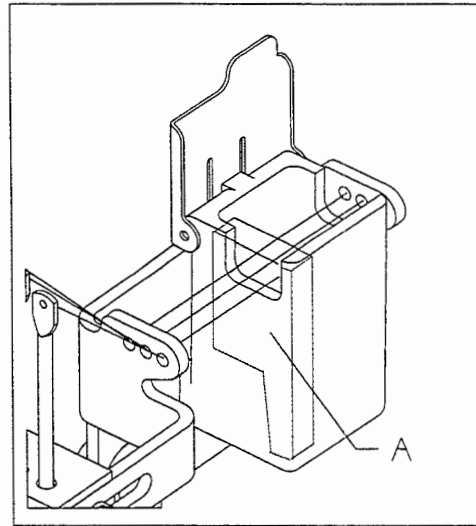

The standard needle is 128 GAS, needle range sizes "090/036 - 150/060."

Insert needle according to the following procedure:

1. Bring needle head (A) to the highest position.
2. Loosen screw (B), insert needle into holes. The needle scarf should face rearwards as viewed from the operator's side.
3. Retighten screw (B).

## THREADING METHODS



CAUTION!

When using an untwisted thread such as wooly nylon or weak thread, do not wind it around the intermediate thread guide.

### Twisted Thread

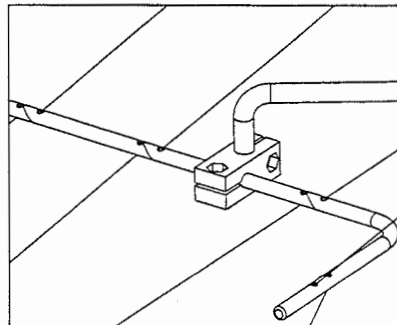

### Non-Twist Thread

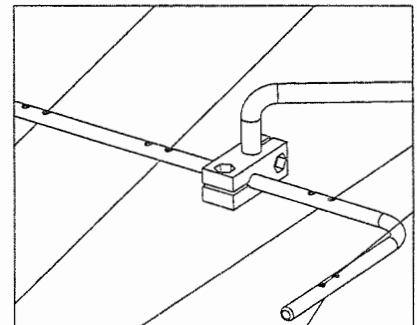

## PRESSER FOOT PRESSURE AND LIFTER:

1. Adjust presser foot pressure by loosening nut (A) and turning presser foot adjust screw (B) clockwise to increase the pressure, counterclockwise to decrease the pressure.
2. Retighten nut (A).

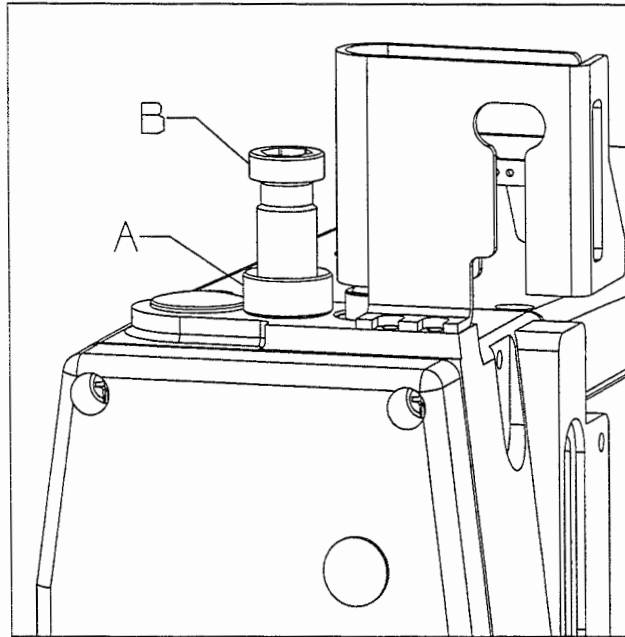

## ADJUSTING THE STITCH LENGTH:



Turn off main power switch before setting the stitch length! When using clutch motors without actuation lock wait until the motor has completely stopped.

1. To change stitch length turn stitch regulating screw (A).  
Clockwise to increase the stitches per inch/shorten the length of one stitch.  
Counterclockwise to decrease stitches per inch/increase the length of one stitch.
2. Numbers 0-11 on stitch regulating screw are for operator's reference only.

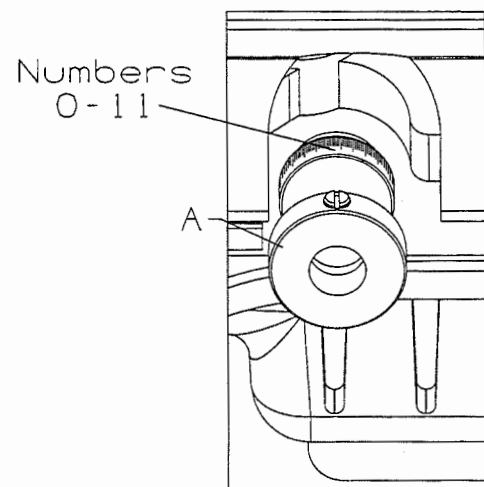

## FEED, NEEDLE LOOPER TIMING:

Set the first screw in operating direction of the feed drive eccentrics to be straight up, then, holding this position, set the needle bar at B.D.C.. Set the looper timing to the needles to be synchronized. Adjust the looper timing with the looper avoid drive sprocket.



## NEEDLE ALIGNMENT:

Torque needle head to 14 to 16 in-lbs (1.6 to 1.8Nm).

Install the feed dog, needles and throat plate. Use the adjustable ferrules to align the needles in the throat plate and align the feed dog so it is centered side to side. Tighten the throat plate support and ferrules in place.

Center Feed Dog In  
Center Of Feed Slots

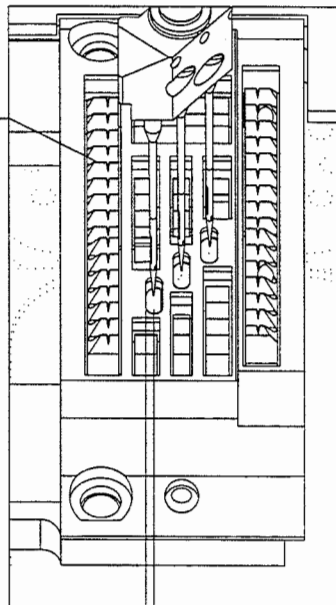

Centered  
3 Places



## LOOPER SETTING:

Use the right needle and looper to set the looper gauge. Set the looper gauge to 1/8" (3.2mm) when loopers at extrem right. Set the loopers front to back to deflect the needles forward .002" to .006" (.05mm to .10mm). set the looper avoid so the needle touches the back of the looper 2/3 down back as needles descend.

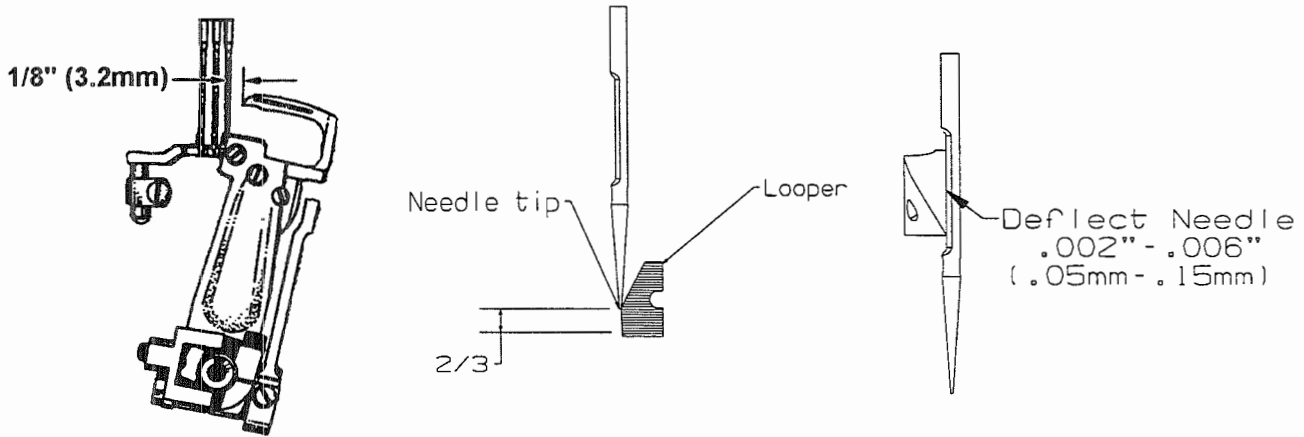

## NEEDLE BAR SETTING:

Set the needle height so when the top of the needle eye is even with the bottom of the looper (on it's travel to the left) the looper tip is .020" (.5mm) past the needle. Use the left needle. Recheck looper setting. Torque needle bar clamp screw to the following specifications:

Torque needle bar@  
18 to 20 in.-lbs. (2.0 to 2.3Nm)

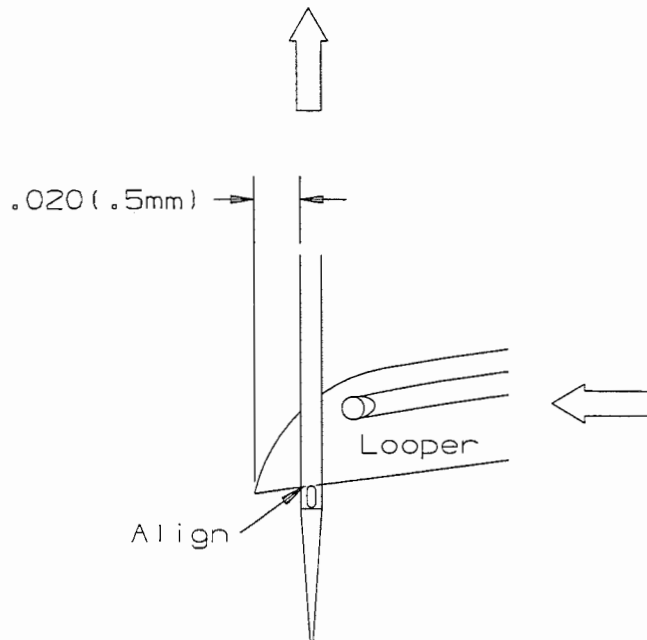

## REAR NEEDLE GUARD:

Set the timing of the rear needle guard so the guard reaches it's furthest travel forward as the loopers enter the scarfs on the travel to the left.

Bring the looper tips to the center of the needles in the scarf. The tip of the needles should be  $3/64''$   $\pm 1/64''$  (1.2mm  $\pm .4$ mm) below the top guarding surface. The guard should just touch the needles up to .002 (.05mm) deflection. The loopers when traveling to the left should just touch the needles to .002 (.05mm) clearance when entering the scarf area.

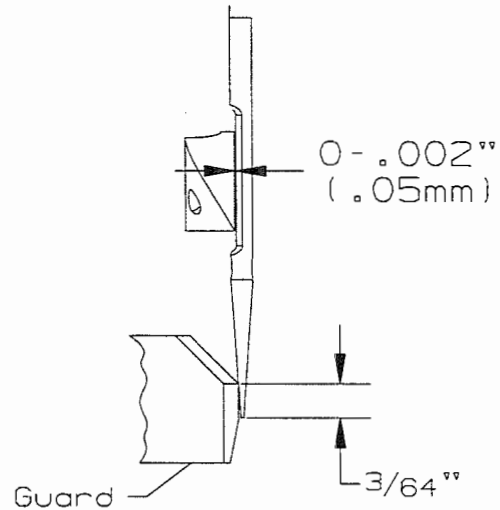
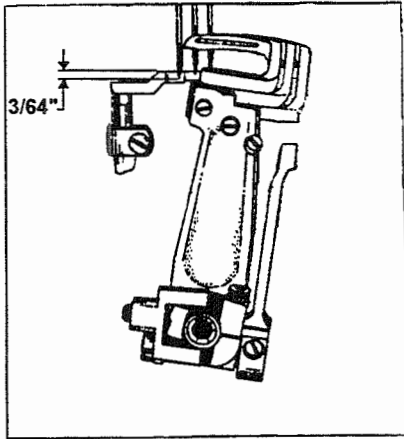

## FEED DOG CENTERING AND HEIGHT ABOVE THROAT PLATE:

Set the machine to its longest stitch length. Center feed dog, front to back, so as to obtain equal clearance on the front side and back side of feed dog in the throat plate slots. Set the feed dogs to come out of the throat plate level. Set feed dog height to be full tooth at the rear when the feed dog is at the top of its stroke.

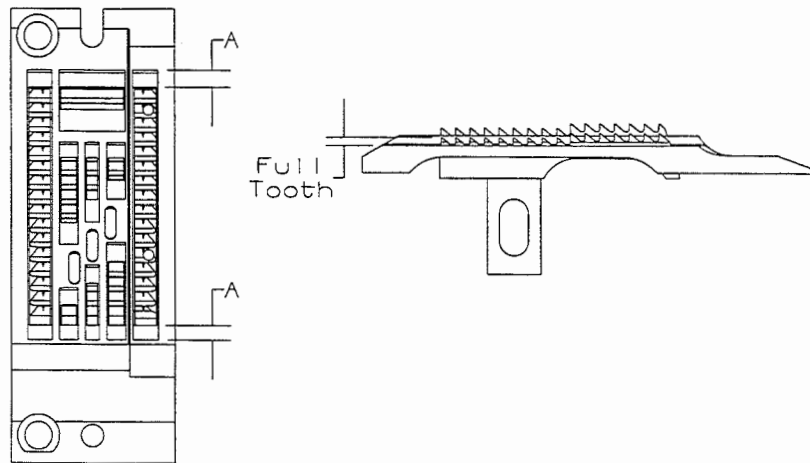

## PRESSER FOOT:

Center the needles in the presser foot needle slots. The presser foot lifter lever stop should be set to when the foot is lifted it does not interfere with the needle head when the needle bar is down.



## LOOPER THREAD TAKE-UP CAM SETTING:

The looper thread cam should be set so that the looper threads cast off the high lobe of the cam as the point of the needles are just even with the under side of the looper. Set the cast-off plate eyelets so that when the looper reaches its left end of travel, all of the looper thread is used and no thread is drawn from the cone. Move down for less. Set the retaining finger so that the finger is even with the bottom edge of its holder and the tip on the right side is touching the cast-off plate.

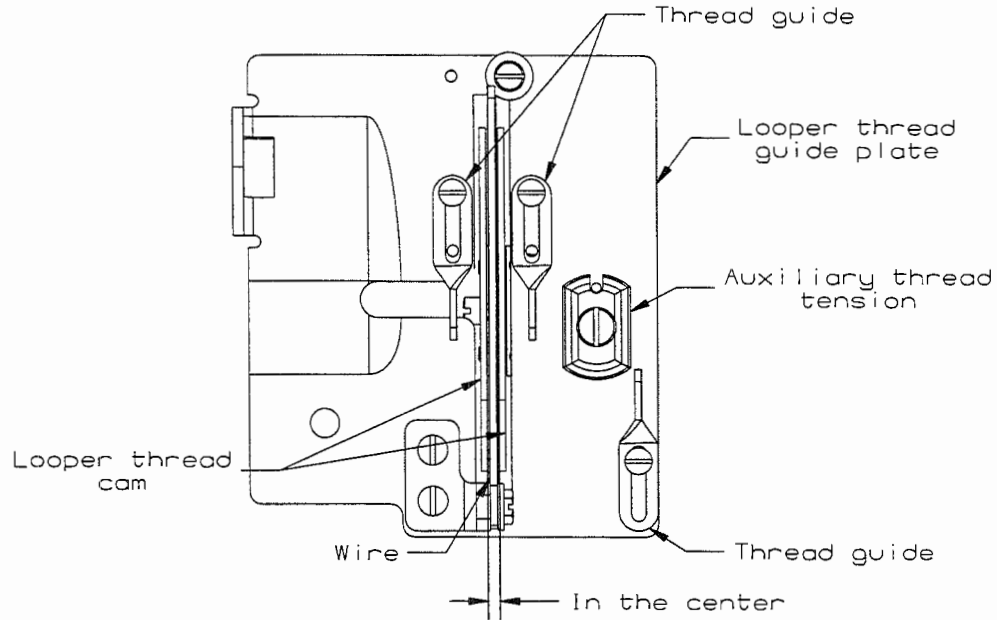

## THREAD CONTROL:

Set the individual needle thread eyelets so they are 25mm below the top casting and to the extreme right when using the mount adapter.

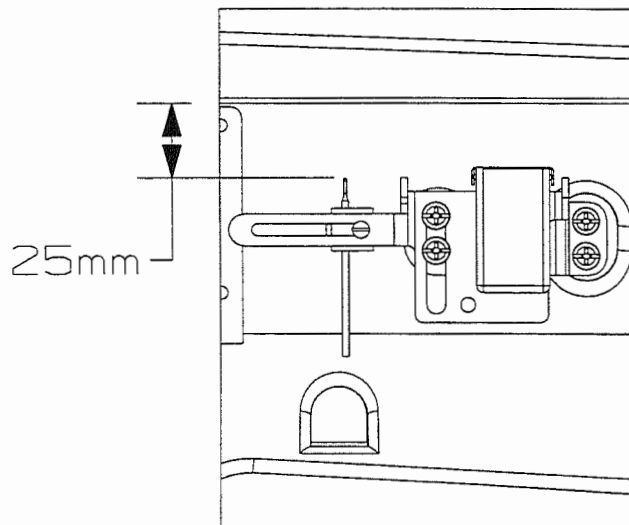

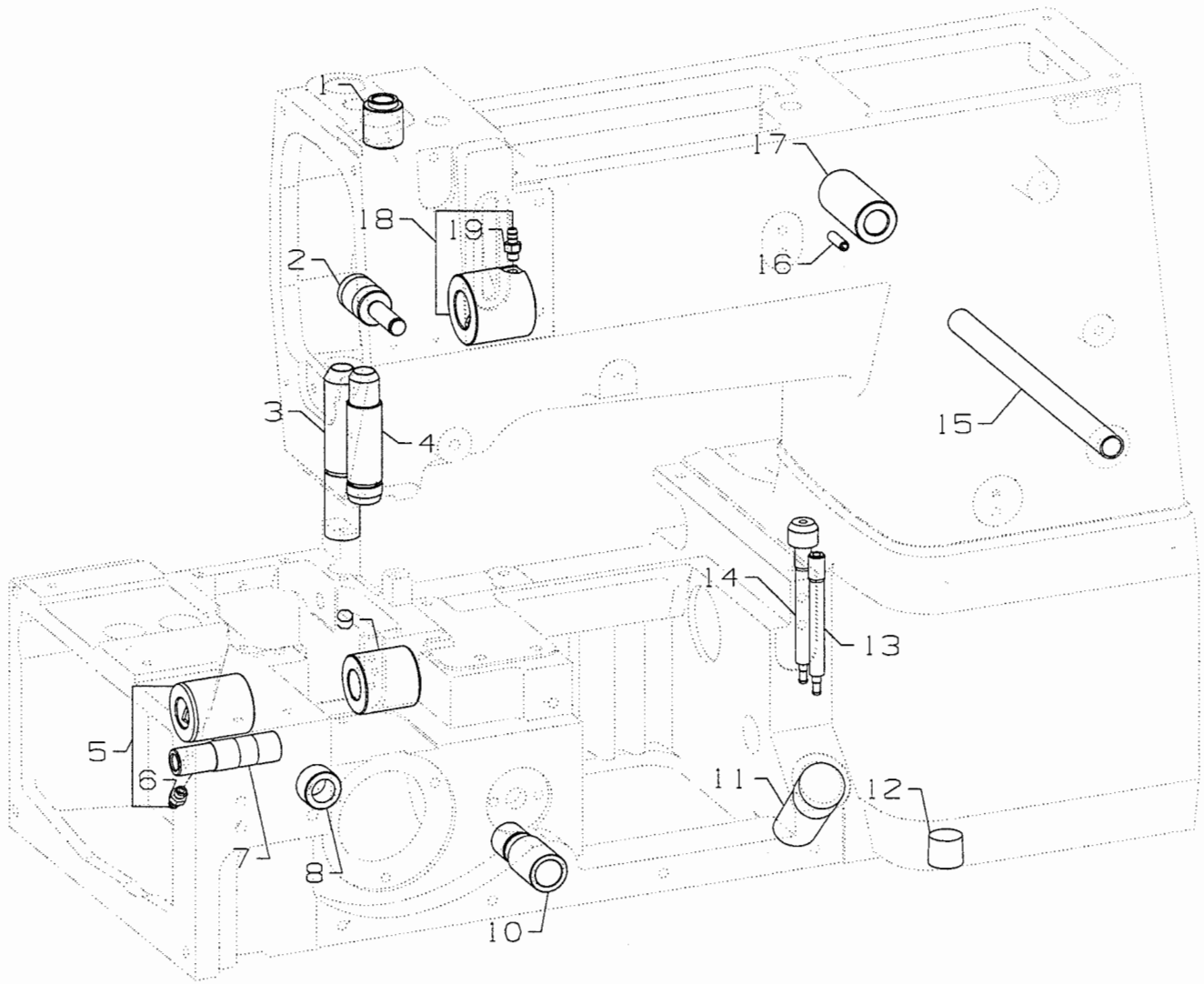

## BUSHINGS

Ref. No.	Part No.	Description	Amt. Req.
1.	50654	Bushing, for needle bar, upper .....	1
2.	50332U	Pin, for front lifter lever .....	1
3.	50330CZ	Bushing, for presser bar .....	1
4.	50654A	Bushing, for needle bar, lower .....	1
5.	50344BE	Bushing, for lower mainshaft, left .....	1
6.	SQ1110401MZ	Fitting .....	1
7.	50344BC	Bushing, for needle lever .....	1
8.	50344E	Bushing .....	1
9.	50344BF	Bushing, for lower mainshaft, right .....	1
10.	35036BS	Stitch Regulator Bushing .....	1
11.	50393GE	Oil Sight Gauge .....	1
12.	22571L	Screw, for drain plug .....	1
13.	50393FU	Fitting, oil tube .....	1
14.	50393EY	Fitting, filter .....	1
15.	50392AB	Bushing, for tension release.....	1
16.	PS0400142KH	Pin .....	1
17.	50381E	Bushing, for lifter lever, back .....	1
18.	50344BU	Bushing, front .....	1
19.	SQ1110401MZ	Fitting .....	1



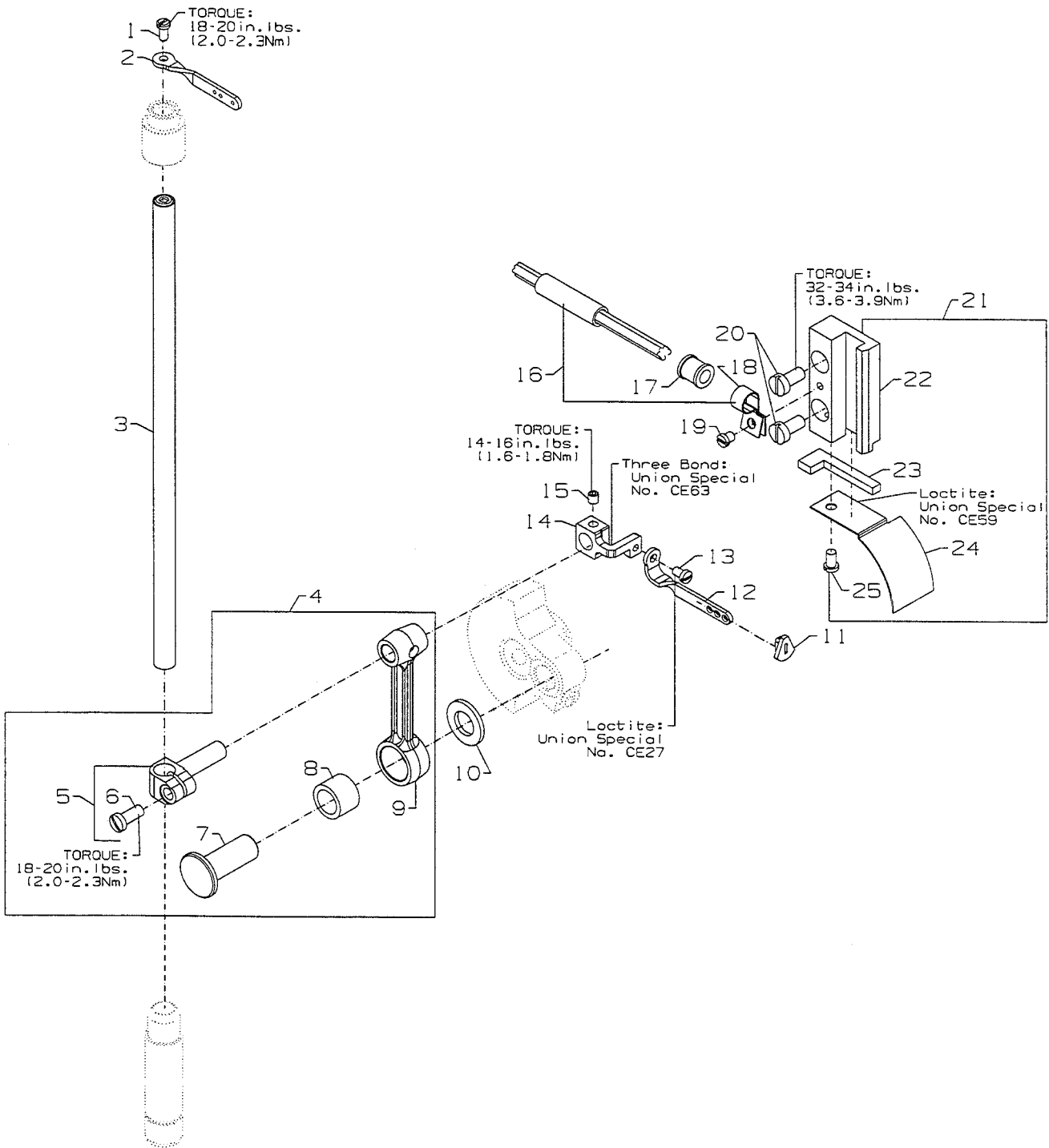

## NEEDLE BAR

Ref. No.	Part No.	Description	Amt. Req.
1.	SS4080620TP	Screw .....	1
2.	50323P	Needle Bar Eyelet .....	1
3.	50317B	Needle Bar .....	1
4.	50345W	Connecting Rod Assembly .....	1
5.	50355AM	Needle Bar Clamp .....	1
6.	SS7111120TP	Screw .....	1
7.	50352	Pivot Pin .....	1
8.	661-259B	Needle Bearing Cage .....	1
9.	50355AN	Connecting Rod .....	1
10.	50351A	Washer .....	1
11.	50393JP	Eyelet Seal .....	1
12.	50358X	Needle Thread Eyelet .....	1
13.	SS7080520SP	Screw .....	1
-	CE27	Loctite Adhesive, (not shown), for screw .....	-
14.	50354F	Slide Block .....	1
-	CE63	Three Bond Adhesive, (not shown), for slide block .....	-
15.	SS8110422TP	Screw .....	1
16.	29476TC	Oil Tube Assembly .....	1
17.	50393JZ	Oil Tube .....	1
18.	50393JW	Hose Clamp .....	1
19.	SS6090440SP	Screw, for oil tube assembly .....	1
20.	SS6121010SP	Screw .....	2
21.	29476VN	Slide Block Guide and Cover Assembly .....	1
22.	50338	Guide, for slide block .....	1
23.	666-328	Felt, for slide block .....	1
-	CE59	Loctite Adhesive, (not shown), for felt .....	-
24.	50338A	Cover, for guide .....	1
25.	SS6090620SP	Screw .....	1



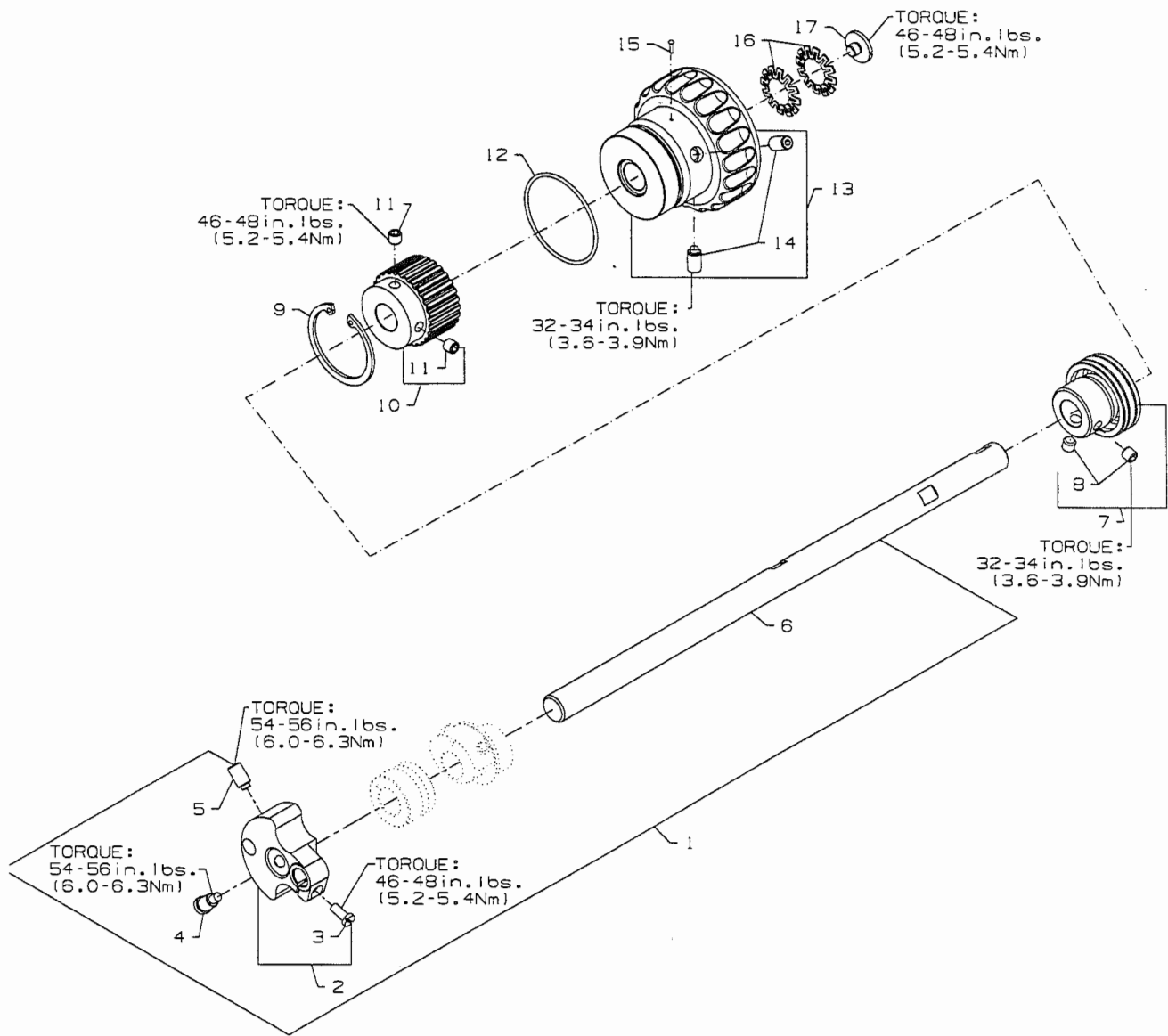

## UPPER MAIN SHAFT

Ref. No.	Part No.	Description	Amt. Req.
1.	50322BC	Upper Main Shaft Assembly .....	1
2.	50691	Counter Weight .....	1
3.	SS7111120TP	Screw, for counter weight .....	1
4.	SS7681410TP	Screw, for counter weight .....	1
5.	SS8681412TP	Screw, for counter weight .....	1
6.	50322AF	Upper Main Shaft .....	1
7.	50335BD	Bearing Adapter Assembly .....	1
8.	SS8660612TP	Screw, for bearing adapter .....	2
9.	661-262	Retaining Ring .....	1
10.	50342BE	Sprocket, for upper main shaft .....	1
11.	SS8661012TP	Set Screw, for sprocket .....	2
12.	660-1087	"O" Ring.....	1
13.	50321F	Handwheel .....	1
14.	SS8681412TP	Set Screw, for handwheel .....	2
15.	660-1043	Tack Pin, for handwheel .....	1
16.	661-261	Load Ring, for lower main shaft .....	2
17.	SS7660520SP	Screw, for handwheel preload .....	1



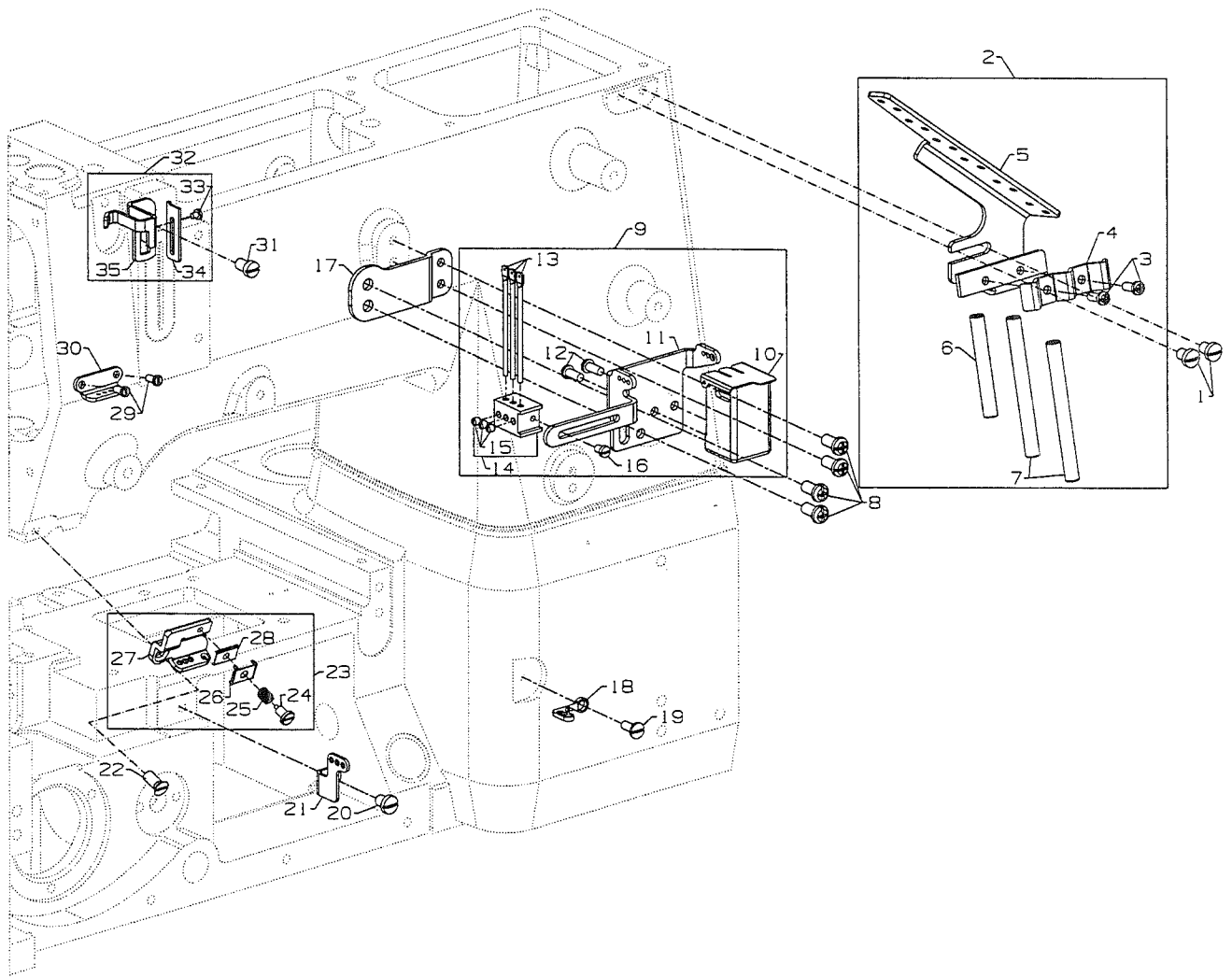

## THREAD GUIDE

Ref. No.	Part No.	Description	Amt. Req.
1.	SS7120640SP	Screw, for lead-in eyelet .....	2
2.	50666A	Thread Eyelet Assembly .....	1
3.	SS4090815SP	Screw .....	2
4.	50666	Tube Bracket .....	2
5.	50692E	Lead-In Tension Eyelet .....	1
6.	50666C	Thread Tube .....	1
7.	50366	Thread Eyelet Tube .....	2
8.	SS4120915SP	Screw, for spreader thread guide .....	2
9.	50663A	Thread Ratio Control Assembly .....	1
10.	50393HH	Silicone Thread Lubricator .....	1
11.	50392V	Needle Thread Guide .....	1
12.	SS4090815SP	Screw, for silicone tank .....	2
13.	36271A	Adjusting Needle Thread Eyelet .....	3
14.	50358W	Holder, For Needle Thread Eyelet .....	1
15.	SS8080410TP	Screw .....	3
16.	SS7080510TP	Screw .....	1
17.	50683	Mounting Bracket .....	1
18.	50658B	Looper Frame Eyelet .....	1
19.	SS7090610SP	Screw .....	1
20.	SS7120640SP	Screw .....	1
21.	50658A	Looper Frame Eyelet .....	1
22.	SS1121010SP	Screw, for thread guide .....	1
23.	50357AE	Nipper Plate Assembly .....	1
24.	SD0380551SL	Screw .....	1
25.	50357AS	Nipper Spring .....	1
26.	50357Y	Nipper Spring Plate .....	1
27.	50392BA	Thread Guide .....	1
28.	50357V	Nipper Plate .....	1
29.	605A	Screw, for needle thread guide .....	2
30.	C50044E	Needle Thread Guide .....	1
31.	SS7120710SP	Screw, for strike-off .....	1
32.	50366B	Needle Thread Strike-Off Assembly .....	1
33.	SS7060310SP	Screw .....	1
34.	50370F	Thread Strike-off Component .....	1
35.	50358V	Needle Thread Strike-off .....	1



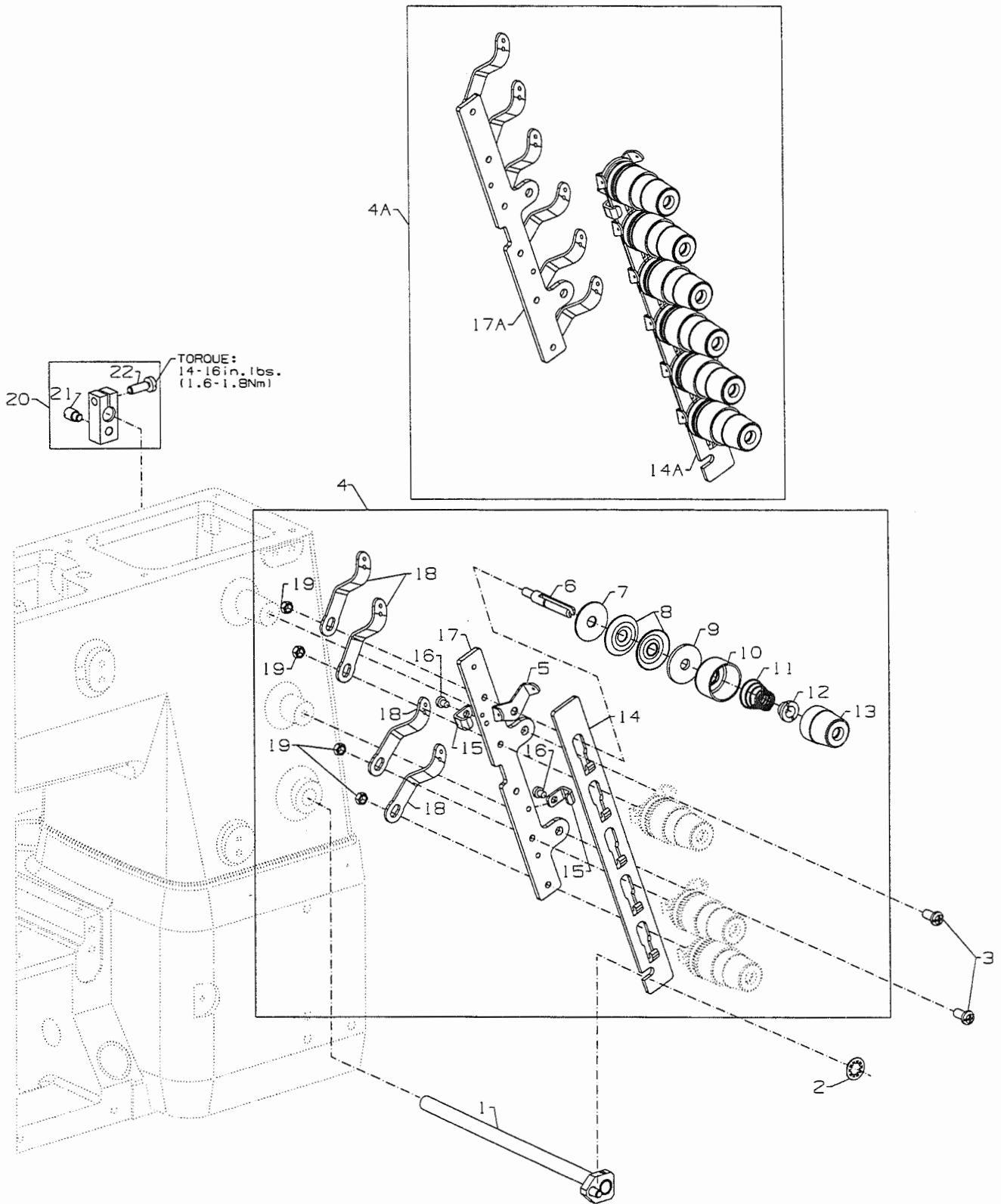

## TENSION RELEASE & THREAD TENSION

Ref. No.	Part No.	Description	Amt. Req.
1.	50392Z	Tension Needle Lever Assembly .....	1
2.	660-283A	Retainer Washer .....	1
3.	SS4120915SP	Screw, for tension assembly .....	2
4.	50692C	Four Thread Tension Assembly .....	1
4A.	50692D	Six Thread Tension Assembly .....	1
5.	57892K	Thread Tension Eyelet .....	4/6
6.	56392G	Tension Post .....	4/6
7.	B3120352000	Tension Disc Felt .....	4/6
8.	B3126012000	Tension Disc .....	8/12
9.	B3120704000	Tension Disc Felt .....	4/6
10.	56392H	Spring Shield .....	4/6
11.	11550100	Spring, needle (Purple) .....	2/3
-	B3103800400	Spring, looper (Blue) .....	2/3
12.	B3112704000	Ferrule, tension spring .....	4/6
13.	50692J	Knob, needle (Purple) .....	2/3
-	56392M	Knob, looper (Blue) .....	2/3
14.	50392W	Tension Disc Separator .....	1
14A.	50692	Tension Disc Separator .....	1
15.	50392AV	Guide, for tension disc separator .....	2
16.	SS7090520SP	Screw, for guide .....	2
17.	50392X	Tension Bracket .....	1
17A.	50692A	Tension Bracket .....	1
18.	57865	Lead-In Thread Guide .....	4/6
19.	NS6110420SP	Nut .....	4/6
20.	50392BC	Tension Release Lever Shaft Connection .....	1
21.	22875N	Stop Screw .....	1
22.	SS7121410TP	Binder Screw .....	1



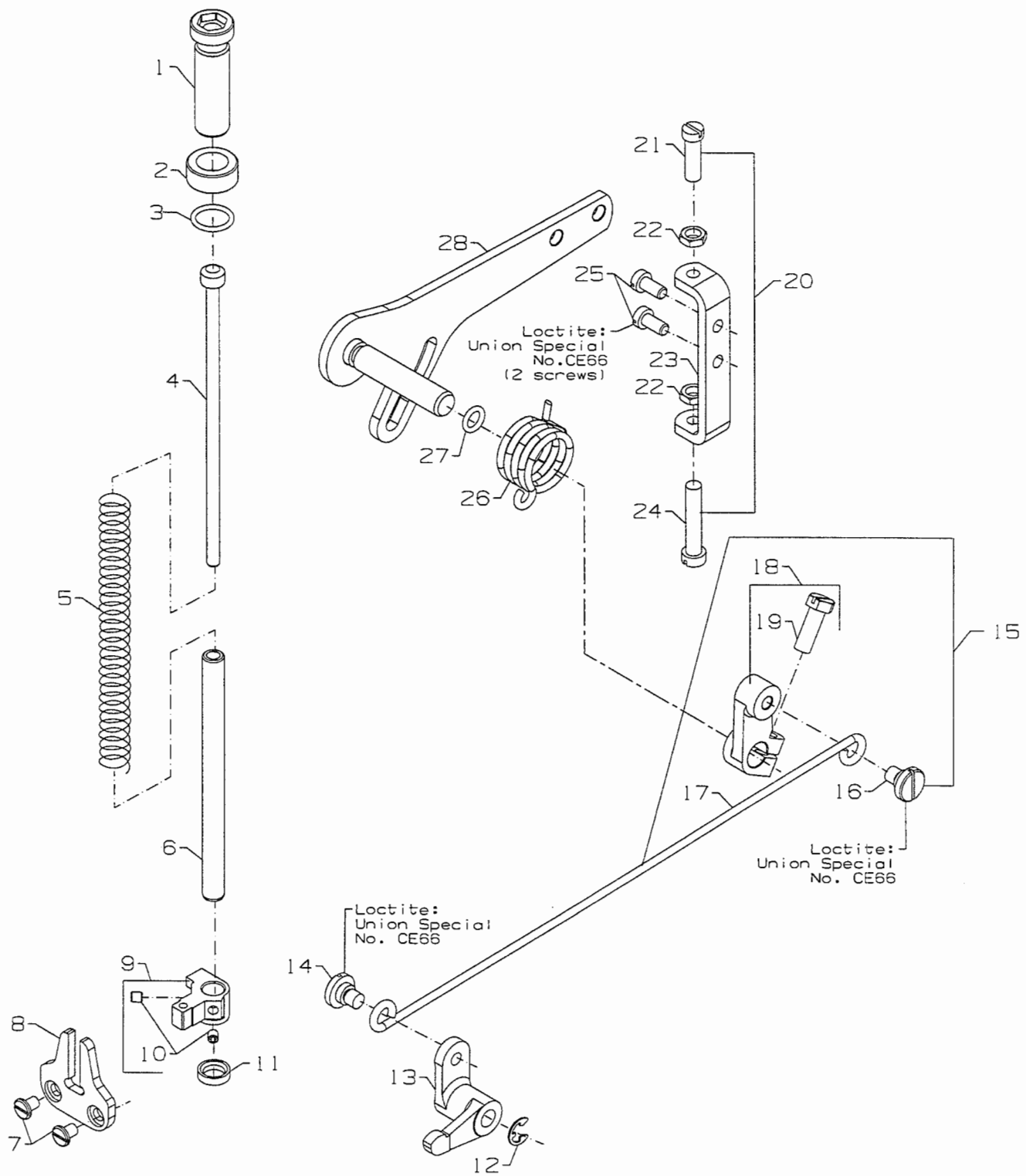

## PRESSER FOOT LIFT

Ref. No.	Part No.	Description	Amt. Req.
1.	11071602	Adjusting Screw, for spring .....	1
2.	11071701	Locking Nut .....	1
3.	660-1014	"O" Ring .....	1
4.	C50056B	Spring Rod .....	1
5.	C50056C	Spring, for presser bar, for S01, S02 machine styles .....	1
6.	50643	Presser Bar, for S01, S02 machine styles .....	1
7.	SS6110610TP	Screw, for guide plate .....	2
8.	50335AG	Guide Plate, for presser bar .....	1
9.	50335AH	Presser Bar Guide .....	1
10.	SS8110422TP	Set Screw .....	2
11.	660-739	Oil Seal .....	1
12.	RE0500000K0	E Ring, for pin .....	1
13.	50381F	Lever, for lifter, front .....	1
14.	SD0790303SP	Screw, for wire connector .....	1
-	CE49	Loctite Adhesive, (not shown), for screw .....	-
15.	29476TK	Rear Lifter Lever Assembly .....	1
16.	SD0790303SP	Screw, for lifter lever assembly .....	1
17.	50355AR	Wire Connector .....	1
18.	50381G	Lifter Lever, rear .....	1
19.	SS9151740CP	Hex Screw .....	1
20.	29476TT	Stop Assembly .....	1
21.	SS6151920SP	Screw, for adjusting stopper .....	1
22.	NS6150310SP	Hex Nut .....	2
23.	50332V	Stopper, for lifter lever .....	1
24.	SS6153040SP	Screw, for adjusting stopper .....	1
25.	SS4121215SP	Screw, for stopper .....	2
-	CE49	Loctite Adhesive, (not shown), for screw .....	-
26.	50381	Spring, for lifter lever .....	1
27.	RO068190100	"O" Ring .....	1
28.	50381B	Lifter Lever Assembly .....	1



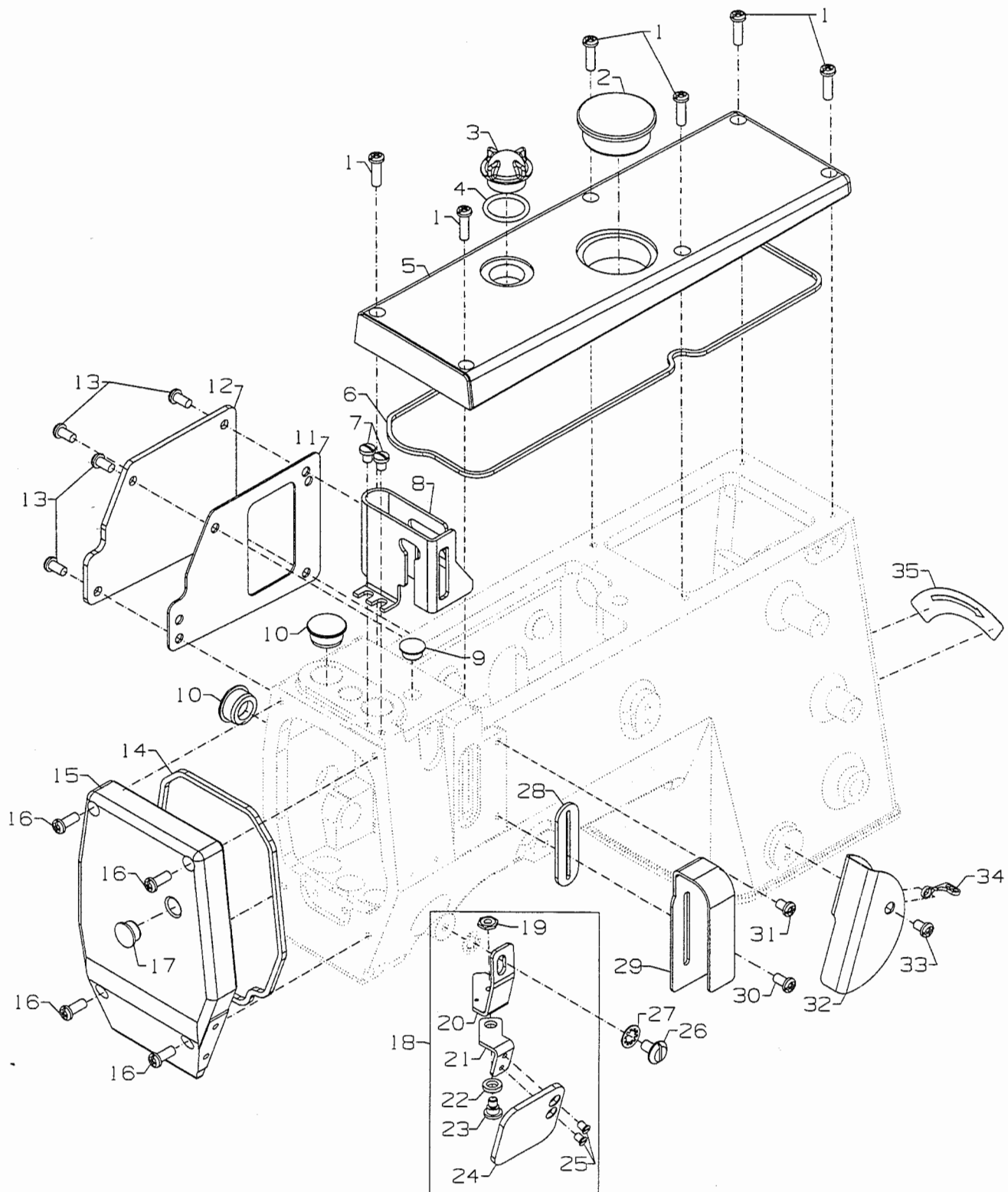

COVERS, UPPER ARM

Ref. No.	Part No.	Description	Amt. Req.
1.	SS4121615SP	Screw, for top cover .....	6
2.	50393EU	Plug, for top cover .....	1
3.	B3530555000	Oil Sight Gauge, top .....	1
4.	660-212	"O" Ring, for oil sight gauge .....	1
5.	50382FW	Top Cover .....	1
6.	50382FZ	Quad Ring, for top cover .....	1
7.	SS7120640SP	Screw, for needle bar guard .....	2
8.	50317C	Needle Bar Guard .....	1
9.	TA1050504RO	Plug, for bed .....	1
10.	50393HB	Plug, for bed .....	2
11.	50384L	Gasket, for puller drive cover .....	1
12.	50382GB	Puller Drive Cover .....	1
13.	SS4120915SP	Screw, for puller drive cover .....	4
14.	50382FY	Quad Ring, for head cover .....	1
15.	50382FX	Head Cover .....	1
16.	SS4121215SP	Screw, for head cover .....	4
17.	TA1100604RO	Plug, for head cover .....	1
18.	99682XCA	Protection Shield Assembly .....	1
19.	NS6620320SP	Nut .....	1
20.	99682XC1	Bracket Holder .....	1
21.	99682XC2	Bracket .....	1
22.	WZ0641510KP	Spring Washer .....	1
23.	SD0640323TP	Shoulder Screw .....	1
24.	99682XC	Protection Shield .....	1
25.	SS1110640SL	Counter Sunk Head Screw .....	2
26.	22517B	Screw .....	1
27.	652C16	Washer .....	1
28.	50393EW	Rubber Gasket, for needle lever .....	1
29.	50382GA	Cover, for thread take-up .....	1
30.	SS4120915SP	Screw, for thread take-up cover .....	1
31.	SS4120615SP	Screw, for thread cover .....	1
32.	50382GM	Thread Cover .....	1
33.	SS4120615SP	Screw, for thread take-up cover .....	1
34.	50658B	Eyelet .....	1
35.	LA452	Label, direction of rotation .....	1



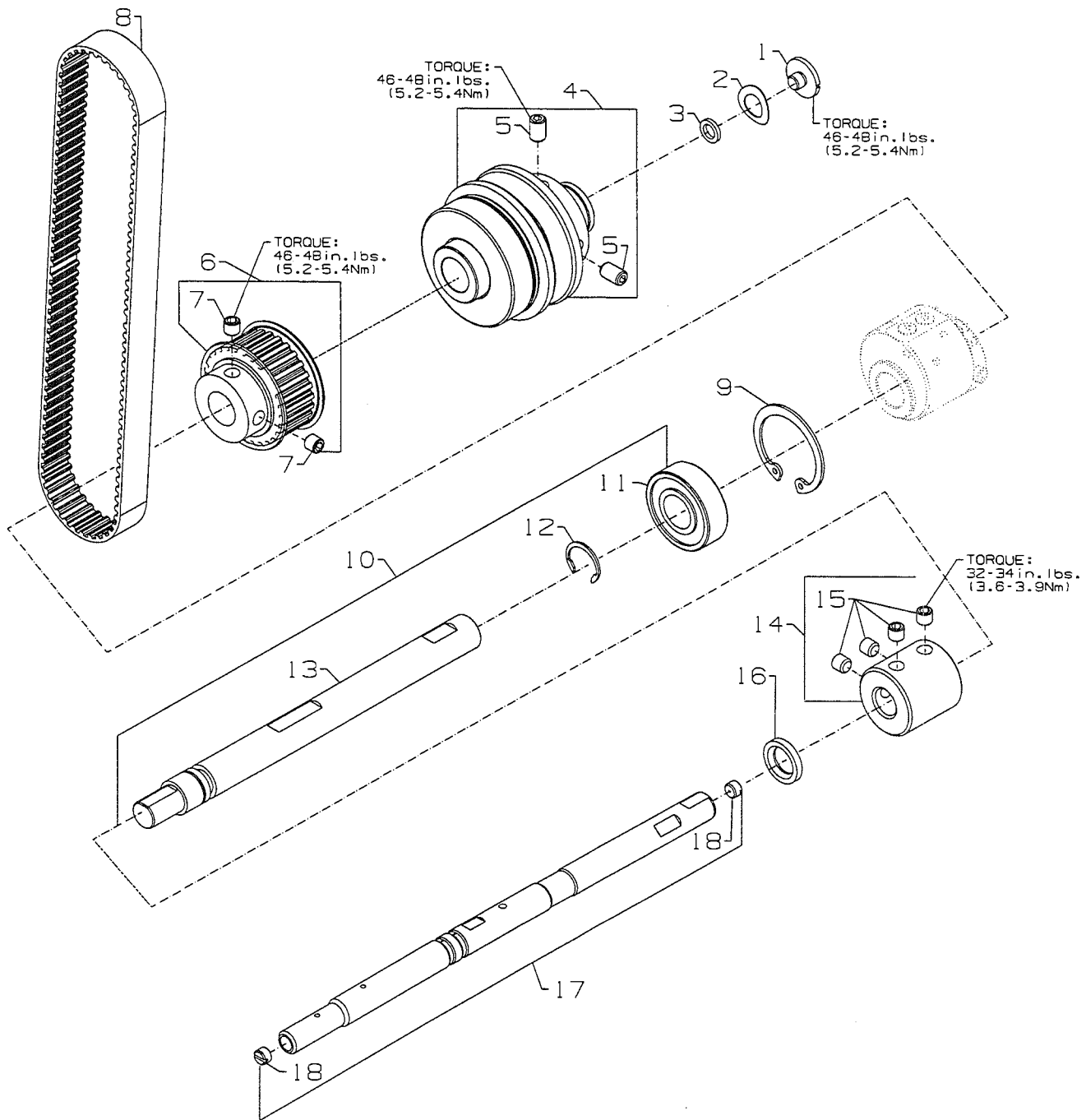

## LOWER MAIN SHAFT

Ref. No.	Part No.	Description	Amt. Req.
1.	SS7660520SP	Shoulder Screw, for lower main shaft, right .....	1
2.	660-1062	Spring Washer .....	1
3.	50374	Spacer, for pulley assembly .....	1
4.	50321G	Pulley Assembly .....	1
5.	SS8661012TP	Set Screw .....	2
6.	50342AX	Sprocket, for lower main shaft .....	1
7.	SS8660612TP	Screw .....	2
8.	50342BS	Timing Belt .....	1
9.	50335AK	Retaining Ring, for ball bearing .....	1
10.	29476UH	Mainshaft Assembly, lower, right .....	1
11.	50322AL	Ball Bearing, for lower main shaft .....	1
12.	50335BB	Retaining Ring .....	1
13.	50322AG	Lower Main Shaft, right .....	1
14.	50333A	Coupling, for lower main shafts .....	1
15.	SS8660612TP	Screw .....	4
16.	660-934	Oil Seal .....	1
17.	50622D	Lower Main Shaft, left for plain feed.....	1
17A.	50622E	Lower Main Shaft, left for differential feed .....	1
18.	SS8660410SP	Screw .....	2



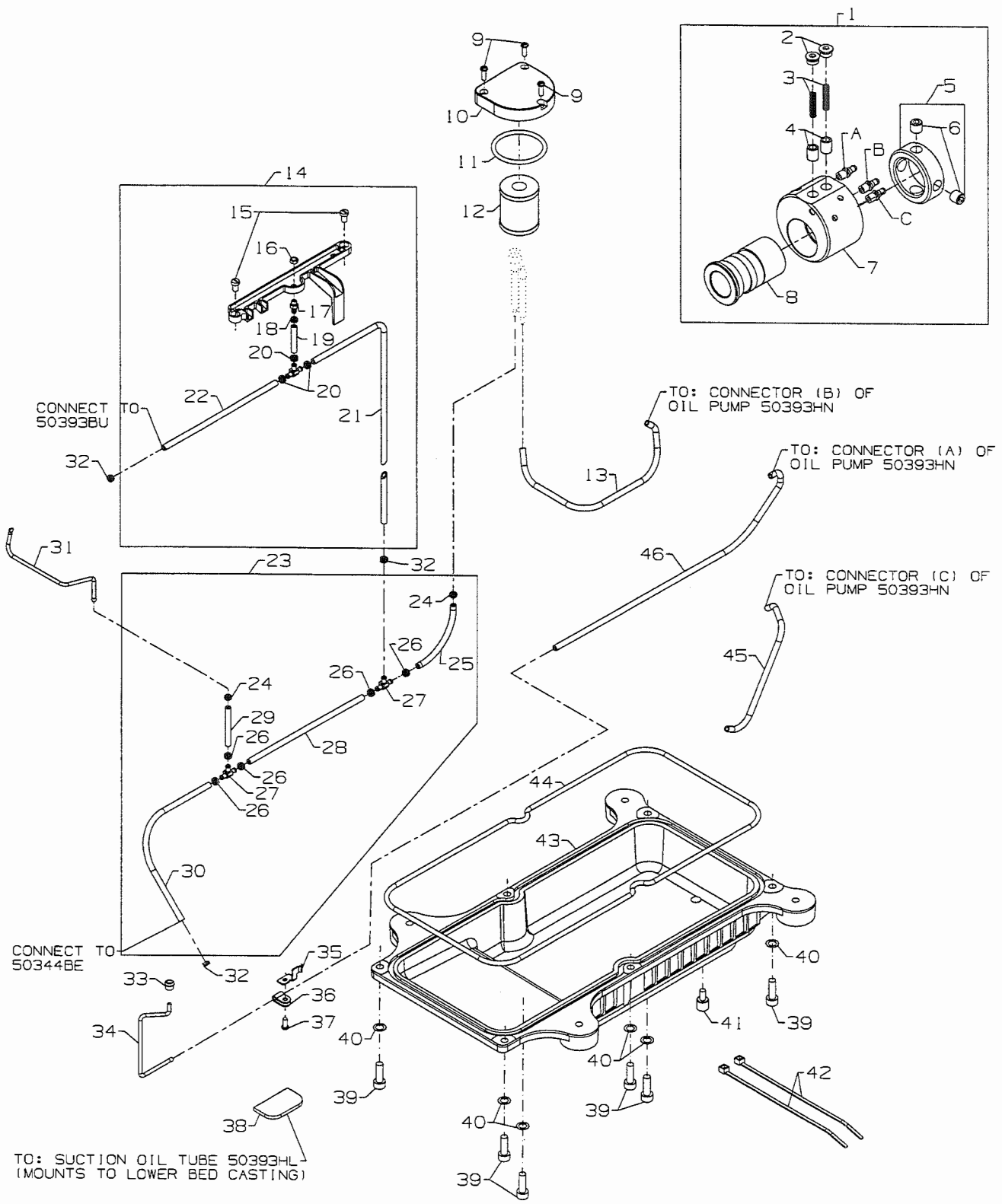

## LUBRICATION, OIL TUBING & OIL PUMP

Ref. No.	Part No.	Description	Amt. Req.
1.	50393HN	Oil Pump Assembly, 2-stage .....	1
2.	SS8660612TP	Screw .....	2
3.	50332S	Spring, for plunger.....	2
4.	34393D	Plunger .....	2
5.	50393EX	Collar, for oil pump .....	1
6.	SS8660612TP	Screw .....	2
7.	50393GB	Oil Pump Housing, 2 Stage.....	1
8.	50393GD	Oil Pump Housing, 2 Stage.....	1
9.	SS4091015SP	Screw, for oil filter cover.....	3
10.	50393FR	Cover, for oil filter.....	1
11.	50384	"O" Ring, for oil filter cover.....	1
12.	11843208	Oil Filter.....	1
13.	50393FV	Oil Tube, for supply (1) .....	1
14.	29476US	Oil Supply Assembly, upper .....	1
15.	SS7120710SP	Screw, for front upper tube .....	2
16.	NS6110310SP	Nut .....	1
17.	SQ1110402MZ	Fitting .....	1
18.	50393KH	Tube Retaining, spring .....	1
19.	50393-27	Oil Tube .....	1
20.	50393KM	Tube Retaining, spring .....	3
21.	50393-447	Oil Tube .....	1
22.	50393-140	Oil Tube .....	1
23.	29476UT	Oil Supply Assembly, lower .....	1
24.	50393KH	Tube Retaining, spring .....	2
25.	50393-70	Oil Tube .....	1
26.	50393KM	Tube Retaining, spring .....	5
27.	13765607	"T" Connector .....	2
28.	50393-140	Oil Tube .....	1
29.	50393-40	Oil Tube .....	1
30.	50393-170	Oil Tube .....	1
31.	50393KF	Oil Tube .....	1
32.	50393KM	Tube Retaining, spring .....	3
33.	50393HR	Plug, for feed chamber .....	1
34.	50393HL	Oil Tube, for suction .....	1
35.	50393FS	Oil Tube Holder .....	1
36.	998-358F	Plastic Clip .....	1
37.	SS4090815SP	Screw, for oil tube holder .....	1
38.	50393HK	Felt .....	1
39.	SS6151812TP	Screw, for oil pan .....	6
40.	WS0631510KP	Spring Washer .....	6
41.	22571E	Screw, for oil drain plug .....	1
42.	RM2871B	Cable Tie .....	2
43.	50393EB	Oil Pan .....	1
44.	50384A	"O" Ring .....	1
45.	50393FT	Oil Tube, for suction .....	1
46.	50393HJ	Oil Tube, for suction .....	1



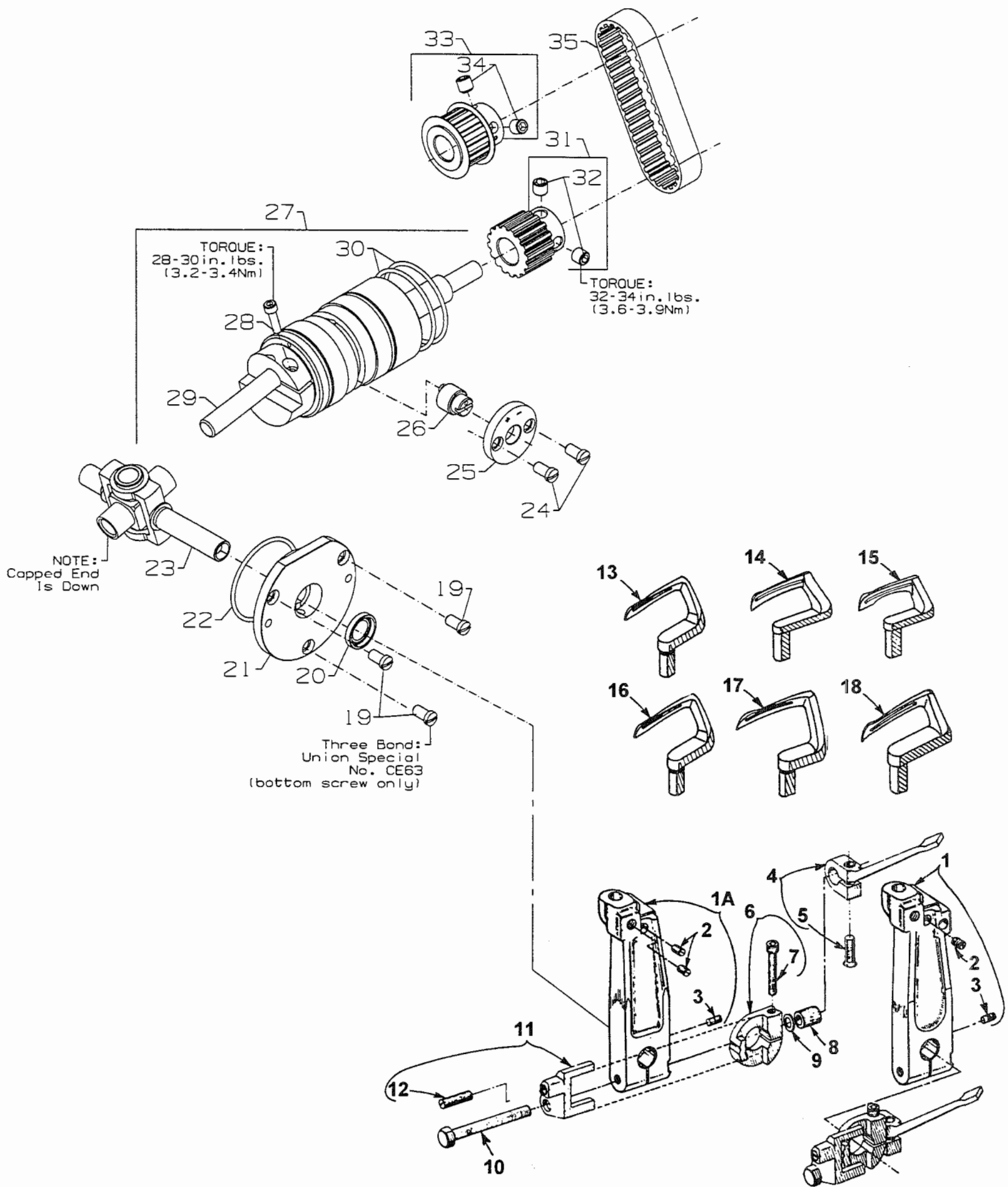

## LOOPER DRIVE

Ref. No.	Part No.	Description	Amt. Req.
1.	50313C	Looper Holder (32 gauge/36 gauge) .....	1
1A.	50313B	Looper Holder (64 gauge/72 gauge) .....	1
2.	22652B10	Screw, for looper holder .....	1
3.	22565	Screw, for looper holder .....	2/3
4.	C50041D	Looper Throwout Lever .....	1
5.	538A	Screw .....	1
6.	C50041H	Collar, Stop .....	1
7.	22652J10	Screw .....	1
8.	C50041E	Lock, Looper Holder .....	1
9.	53634C	Washer .....	1
10.	22881C	Screw .....	1
11.	C50041G	Stop .....	1
12.	C50041F	Spring, Plunger .....	1
13.	51909C	Looper, Rear (64 gauge/72 gauge) .....	1
14.	51508M16	Looper, Front (64 gauge) .....	1
15.	51508M18	Looper, Front (72 gauge) .....	1
16.	51909C	Looper, Middle (all gauges) .....	1
17.	51909D8	Looper, Rear (32 gauge) .....	1
-	51909D9	Looper, Rear (36 gauge) .....	1
18.	51908B8	Looper, Front (32 gauge) .....	1
-	51908B9	Looper, Front (36 gauge) .....	1
19.	SS7120910SP	Screw, for bearing housing .....	3
-	CE63	Three Bond Adhesive, (not shown), for screw .....	-
20.	660-893	Oil Seal, looper .....	1
21.	50344AM	Bearing Housing Assembly, for looper drive .....	1
22.	660-455	"O" Ring, for bearing housing assembly .....	1
23.	50313J	Looper Rocker Assembly .....	1
24.	SS7120910SP	Screw, for retaining plate .....	2
25.	50314F	Eccentric Retaining Plate .....	1
26.	50314E	Looper Avoid Adjusting Eccentric .....	1
27.	50642	Looper Drive Assembly .....	1
28.	22653J8	Screw .....	1
29.	667J33	Crank Pin .....	1
30.	660-979	"O" Ring .....	2
31.	50342BJ	Sprocket, for looper driven .....	1
32.	SS8660612TP	Screw .....	2
33.	50342BK	Sprocket, for looper drive .....	1
34.	SS8660612TP	Screw .....	2
35.	50342BP	Looper Drive Belt .....	1



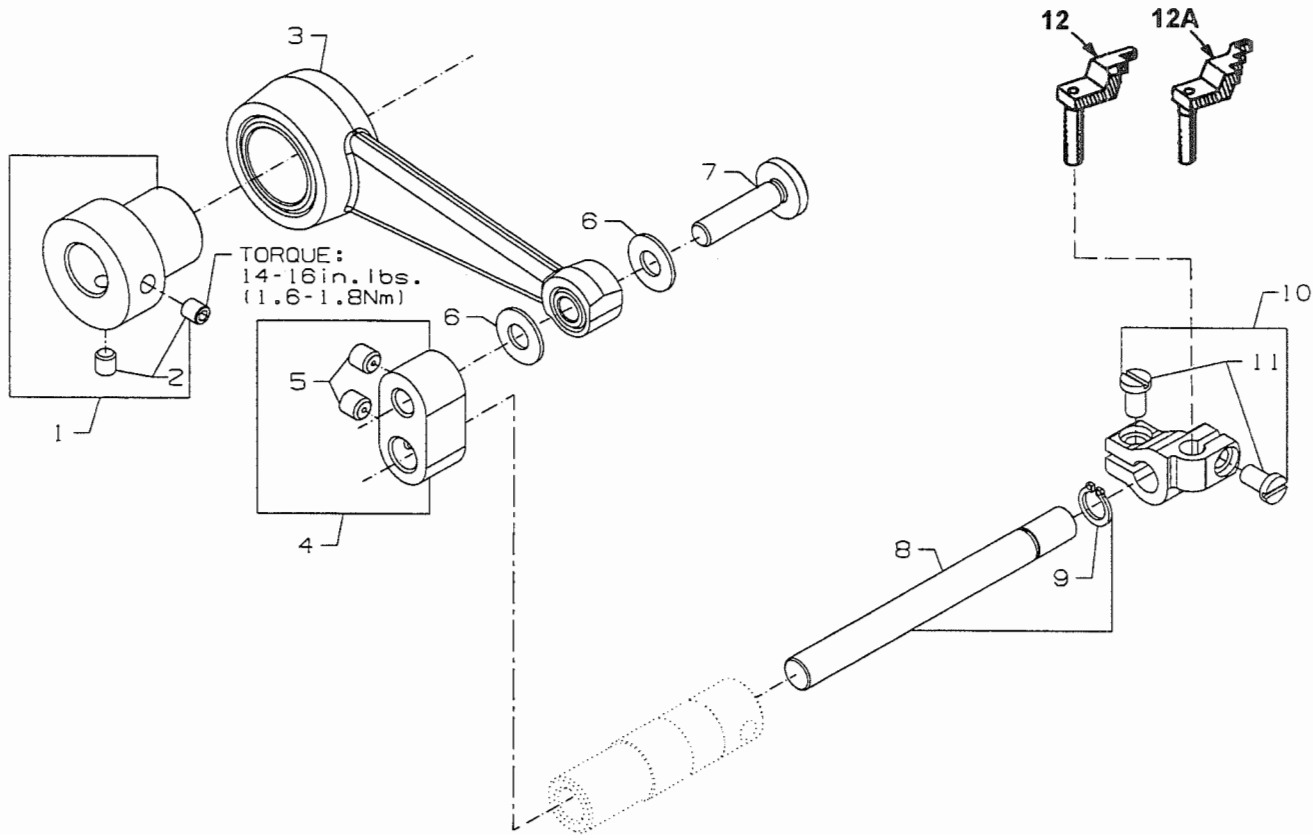

## NEEDLE GUARD

Ref. No.	Part No.	Description	Amt. Req.
1.	50373DA	Needle Guard Eccentric .....	1
2.	SS8110422TP	Screw, for needle guard eccentric .....	1
3.	50368W	Connecting Rod Assembly, for needle guard .....	2
4.	50668	Pivot Link .....	1
5.	SS8110422TP	Screw .....	1
6.	50368E	Washer .....	2
7.	50368A	Pivot Pin .....	2
8.	50622C	Shaft, for needle guard .....	1
9.	RC0560711KP	Retaining Ring .....	1
10.	50625	Holder, for needle guard .....	1
11.	SS6090620SP	Screw .....	2
12.	C50025L	Needle Guard, Rear (64 Gauge/72 Gauge).....	1
12A.	C50025E	Needle Guard, Rear (32 Gauge/36 Gauge).....	1



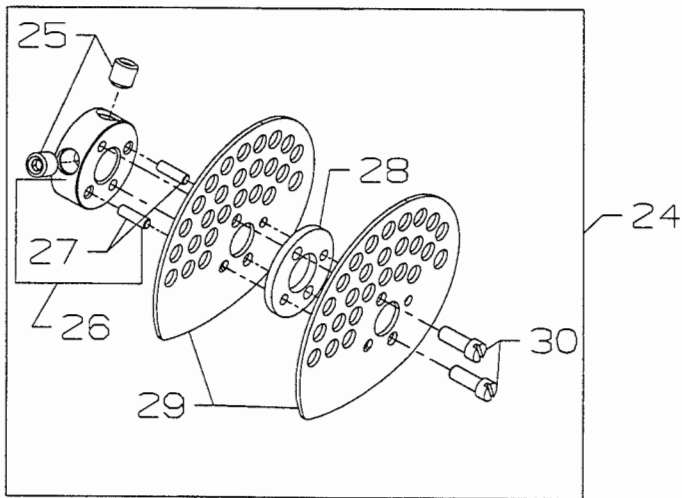
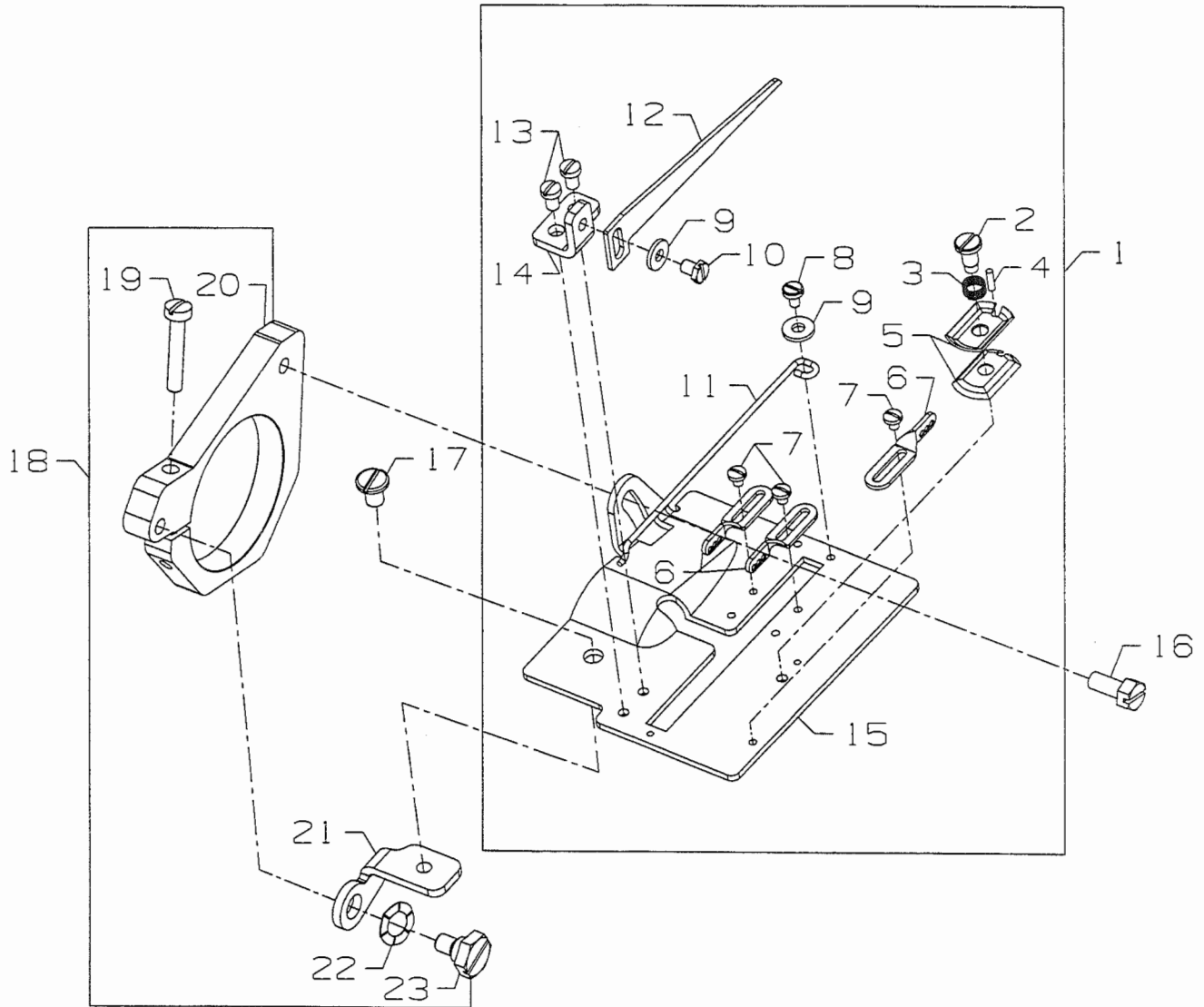

## LOOPER THREAD TAKE-UP

Ref. No.	Part No.	Description	Amt. Req.
1.	50657A	Cast-Off Plate Assembly .....	1
2.	SD0380551SL	Screw .....	1
3.	50332AC	Tension Spring .....	1
4.	50347R	Pin .....	1
5.	51959B	Tension Disc .....	2
6.	50358H	Eyelet .....	3
7.	SS7060310SP	Screw .....	3
8.	SS6060440TP	Screw .....	1
9.	41358	Washer .....	2
10.	SS9080410SP	Screw .....	1
11.	50304H	Strike-Off Wire .....	1
12.	50604	Retaining Finger .....	1
13.	SS7080520SP	Screw .....	2
14.	50383E	Mounting Bracket .....	1
15.	50357AN	Cast-Off Plate .....	1
16.	SS9111010SP	Screw, for collar bracket .....	1
17.	SS6110610TP	Screw, for cast-off holder .....	1
18.	29476UK	Cast-Off Plate Holder Assembly .....	1
19.	SS7092110TP	Screw, for collar bracket .....	1
20.	50383F	Take-up Collar Bracket .....	1
21.	50304K	Cast-Off Plate Holder .....	1
22.	WZ0640200KP	Washer .....	1
23.	SD0630275SP	Shoulder Screw, for cast-off plate holder .....	1
24.	50623B	Take-up Assembly .....	1
25.	22894C	Set Screw .....	2
26.	50323B	Take-up Hub .....	1
27.	22-348	Pin .....	2
28.	C50077P	Spacer .....	1
29.	50323L	Disc, for take-up .....	2
30.	77B	Screw, for take-up disc .....	2



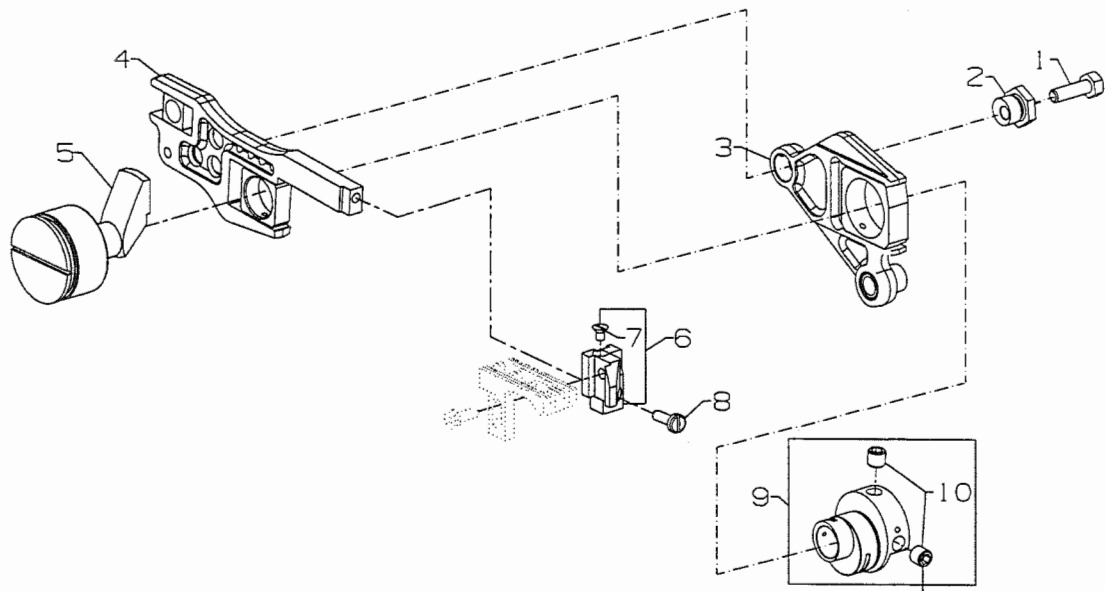

TORQUE:  
 32-34 in. lbs.  
 (3.6-3.9 Nm)

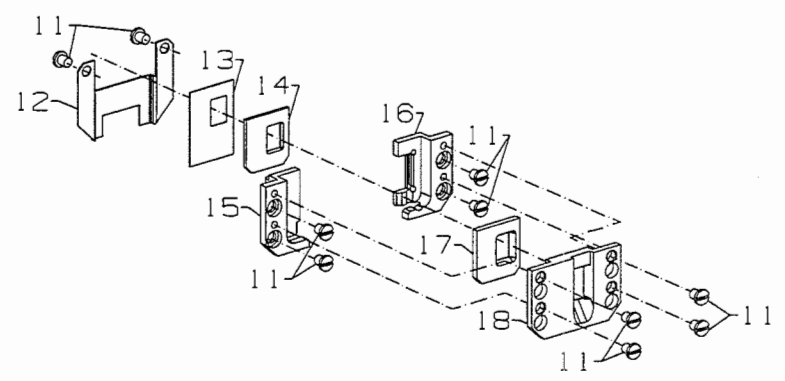

## FEED DRIVE MECHANISM

Ref. No.	Part No.	Description	Amt. Req.
1.	18-1432	Screw .....	1
2.	50334BD	Hex Eccentric Stud .....	1
3.	29126FB	Drive Fork Assembly, right .....	1
4.	50634	Feed Bar Assembly .....	1
5.	50334A	Plain Feed Bar Guide .....	1
6.	50634E	Feed Dog Holder .....	1
7.	22637P24	Screw .....	1
8.	SS7091110TP	Screw .....	1
9.	50640-29	Feed Eccentric, main .....	1
10.	SS8660612TP	Screw .....	2
11.	SS7090530SP	Screw .....	10
12.	50334Y	Oil Shield .....	1
13.	50334W	Oil Scraper .....	1
14.	50634C	Feed Bar Seal .....	1
15.	50637A	Guide Plate, left, rear .....	1
16.	50335BA	Guide Plate, right, rear .....	1
17.	50634D	Feed Bar Seal .....	1
18.	50637	Guide Plate, front .....	1



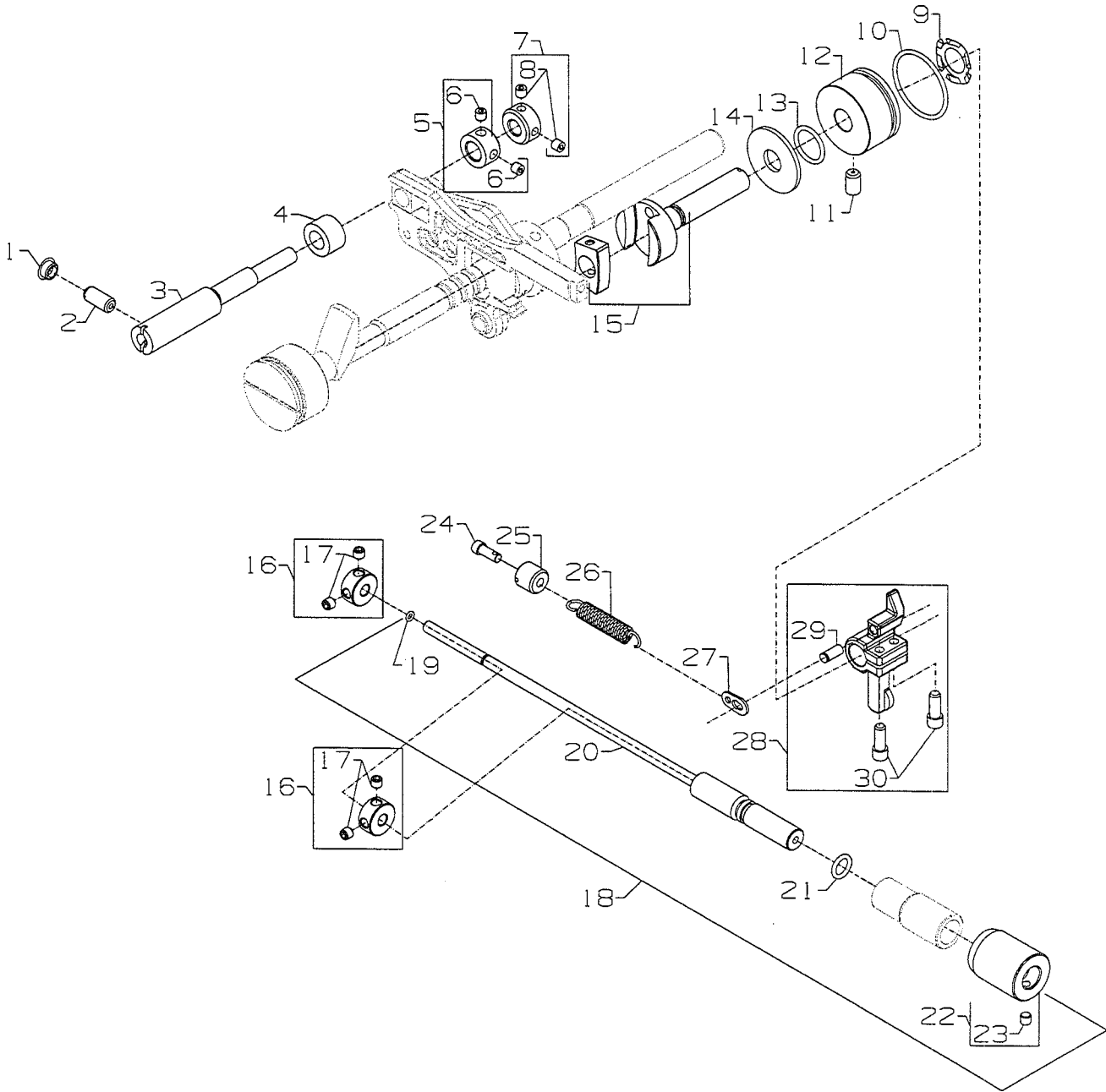

## FEED DRIVE MECHANISM

Ref. No.	Part No.	Description	Amt. Req.
1.	TA075404RO	Plug, for eccentric shaft .....	1
2.	22591A	Screw, for eccentric shaft .....	1
3.	50334BC	Eccentric Shaft .....	1
4.	50674	Washer, for eccentric shaft .....	1
5.	50334BB	Collar, for eccentric shaft .....	1
6.	SS8110422TP	Screw, for collar .....	2
7.	50337T	Collar, for eccentric shaft .....	1
8.	SS8110422TP	Screw, for collar .....	2
9.	661-96	Spring Washer .....	1
10.	660-969	"O" Ring, for bushing .....	1
11.	SS8661012TP	Screw, for bushing .....	1
12.	35036F	Bushing, for stitch adjusting shaft .....	1
13.	660-220	"O" Ring, for stitch adjusting shaft .....	1
14.	35036AZ	Brake Pad .....	1
15.	50634G	Stitch Adjusting Shaft Assembly .....	1
16.	50335D	Collar .....	2
17.	22894P	Screw .....	4
18.	29476UF	Stitch Length Adjusting Rod Assembly .....	1
19.	660-980	"O" Ring, stitch control shaft .....	1
20.	50322AR	Shaft, for stitch control .....	1
21.	660-206	"O" Ring, for stitch control shaft .....	1
22.	50336Y	Stitch Knob, indicator .....	1
23.	SS8110422TP	Screw .....	1
24.	50335	Spring Retainer .....	1
25.	22714C	Screw, for spring retainer .....	1
26.	50355	Spring .....	1
27.	50335A	Spring Holder .....	1
28.	50336S	Stitch Control Lever .....	1
29.	661-35	Pin .....	1
30.	22596H	Screw .....	2

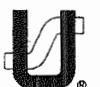



## COVERS, LOWER BED

Ref. No.	Part No.	Description	Amt. Req.
1.	18-1448	Screw .....	11
2.	50601F	Cloth Plate, left .....	1
3.	50601E	Cloth Plate, right .....	1
4.	50303B	Acoustic Pad .....	1
5.	SS6121212TP	Screw, for cover .....	6
6.	50382CP	Cover, for feed chamber .....	1
7.	50382CS	Gasket .....	1
8.	22839C	Screw, for cover .....	3
9.	50382JR	Cover, for dry chamber .....	1
10.	50384K	Gasket, for dry chamber cover .....	1
11.	SS7150740SP	Screw .....	2
12.	22587N	Screw .....	2
13.	35036AE	Ferrule, Locating .....	2
14.	50380D	Throat Plate Support, complete .....	1
15.	51280K	Pin .....	1
16.	660-939	Rubber Bumper, for Throat Plate Support .....	1
17.	C067D	Cork .....	2
18.	22517	Screw, for bed .....	2
19.	50382CR	Gasket .....	1
20.	50382CL	Cover, rear, for feed chamber, .....	1
21.	SS4120615SP	Screw, for cover .....	2
-	CE63	Three Bond Adhesive, (not shown), for screw .....	-



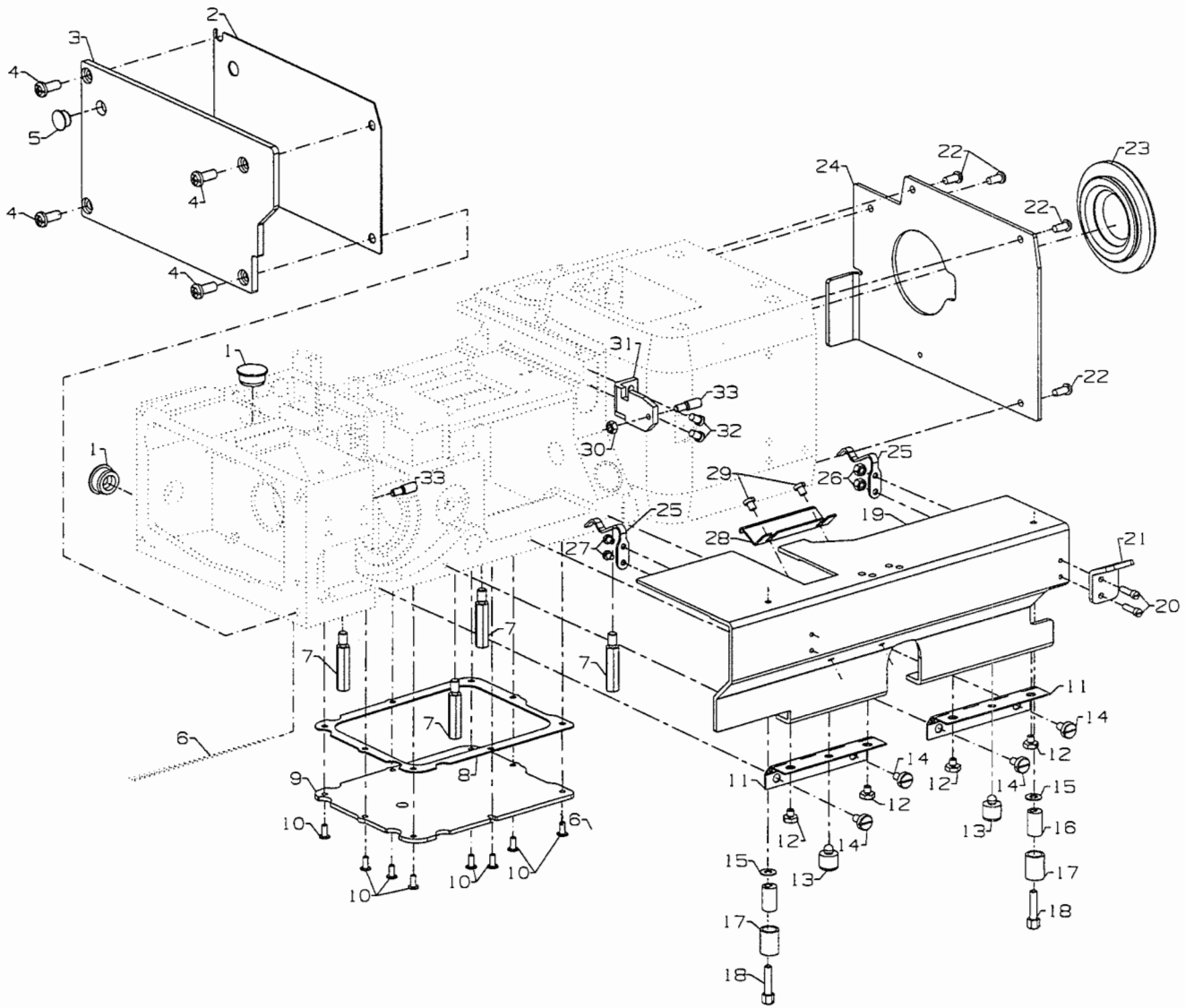

## COVERS, LOWER BED

Ref. No.	Part No.	Description	Amt. Req.
1.	50393HB	Plug, for bed .....	2
2.	50684A	Quad Ring, for left end cover .....	1
3.	50682B	Left End Cover .....	1
4.	SS4151415SP	Screw .....	4
5.	50393HA	Plug .....	1
6.	WO3	Oil Wick, for needle guard .....	1
7.	22841U	Machine Support Stud .....	4
8.	50383G	Gasket, for chamber cover .....	1
9.	50382CG	Dry Chamber Cover .....	1
10.	SS7090850SP	Screw .....	8
11.	50378S	Hinge .....	2
12.	SS9110543CP	Screw .....	4
13.	660-1020	Rubber Bumper .....	2
14.	SS6120930TP	Screw .....	4
15.	20	Washer .....	2
16.	50382T	Stop, for front cover .....	2
17.	50393W	Rubber Bumper .....	2
18.	22519J	Screw .....	2
19.	50682D	Swing Down Cover .....	1
20.	22729D	Screw .....	2
21.	50667	Lever .....	1
22.	SS4121015SP	Screw .....	4
23.	50393HU	Plug, right end, non-synchronizer .....	1
24.	50382CJ	Cover, for drive belt .....	1
25.	50332A	Latch Spring .....	2
26.	39250J	Nut .....	2
27.	22513D	Screw .....	2
28.	50382FP	Latch, looper throw-out safety .....	1
29.	25CC	Screw .....	2
30.	35569J	Nut .....	1
31.	50332B	Support Block .....	1
32.	SS7120710SP	Screw .....	2
33.	22799AH	Spring Latch Stud .....	2



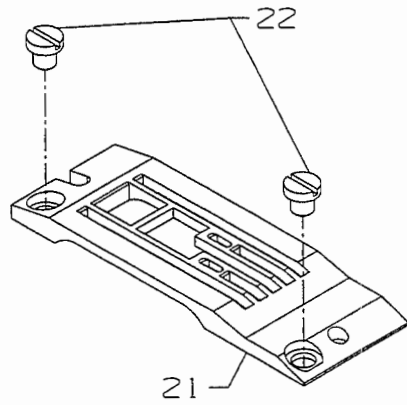
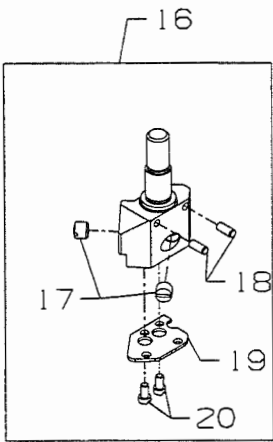
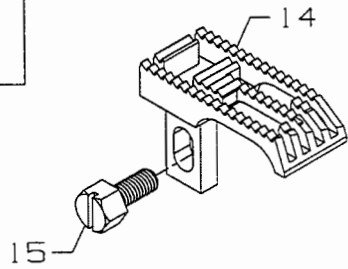
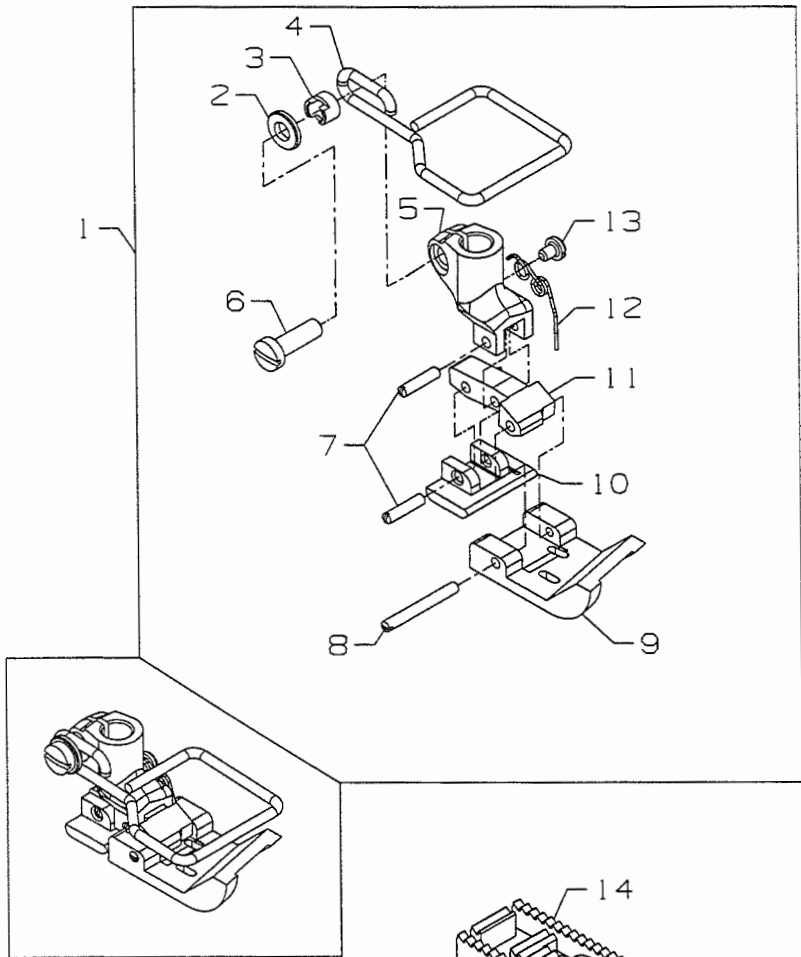

MODEL	NEEDLE HEAD	PRESSER FOOT ASSEMBLY	THROAT PLATE	FEED DOG
FS311L51-2H64	50618-16	50620HR64	50624HR64	50605HR
FS311L51-2H72	50618-18	50620HR72	50624HR72	



## SEWING PARTS

Ref. No.	Part No.	Description	Amt. Req.
1.	-----	Presser Foot Assy. for sewing comb., (see chart) .....	1
2.	21695L	Washer .....	1
3.	21695M	Collar .....	1
4.	21695N	Guard .....	1
5.	35730AD	Presser Foot Shank .....	1
6.	22585R	Screw .....	1
7.	22799G	Hinge Screw .....	2
8.	22799C	Hinge Screw .....	1
9.	50630A64	Presser Foot Bottom, (front section) 64 gauge .....	1
-	50630A72	Presser Foot Bottom, (front section) 72 gauge .....	1
10.	51530J	Presser Foot Bottom .....	1
11.	35730AC	Hinge Section .....	1
12.	35730AE	Spring .....	1
13.	73A	Screw .....	1
14.	50605HR	Feed Dog .....	1
15.	18-1481	Screw .....	1
16.	-----	Needle Head (see chart) .....	1
17.	SS8080310TP	Screw .....	2
18.	660-1046	Pin .....	2
19.	50618F	Needle Head Eyelet, 64 gauge .....	1
19A.	50618E	Needle Head Eyelet, 72 gauge .....	1
20.	22655B7	Screw .....	2
21.	-----	Throat Plate (see chart) .....	1
22.	22570	Screw .....	2



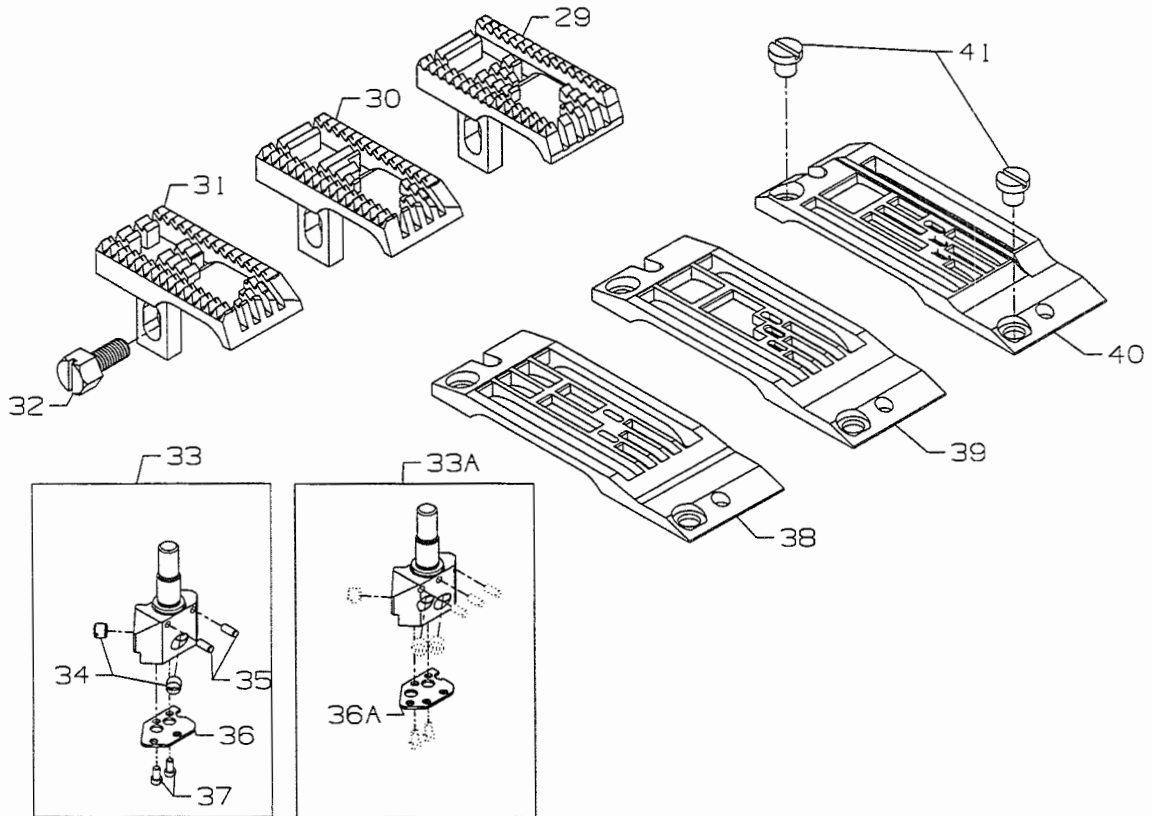
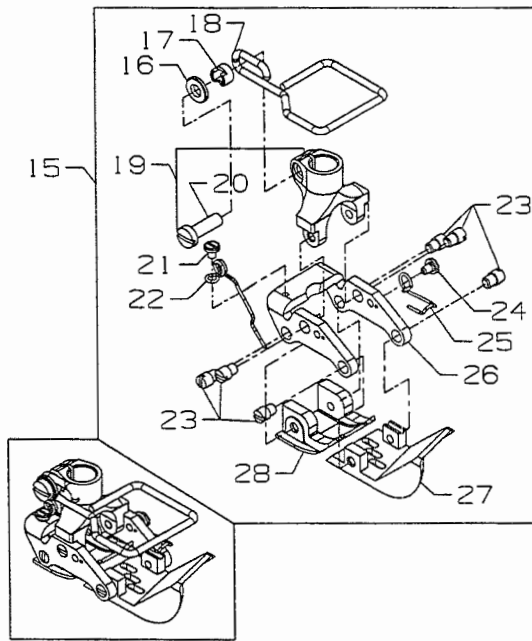
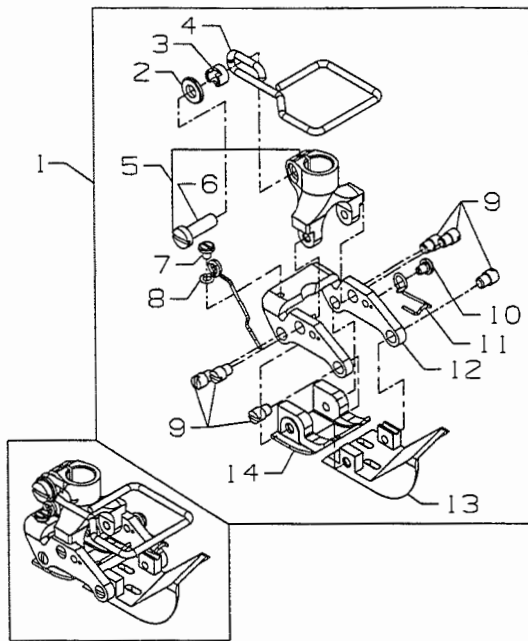

MODEL	NEEDLE HEAD	PRESSER FOOT ASSEMBLY	THROAT PLATE	FEED DOG
FS31 1L52-2H64	50618-16	C50020F16	C50024R16	C50005N
FS31 1L52-2H72	50618-18	C50020E18	C50024U18	
FS31 1L52-3H32	50618B	50320M8	50324N8	56905A9
FS31 1L52-3H36	50618C	56920A9	C56924A9	
FS31 1L53-3H32	50618B	50320N8	50324P8	56905R9
FS31 1L53-3H36	50618C	56920R9	C56924R9	



## SEWING PARTS

1.	-----	Presser Foot Assy. for sewing comb., FL52-2H72, FL52-2H72 (see chart) ....	1
2.	21695L	Washer .....	1
3.	21695M	Collar .....	1
4.	21695N	Guard .....	1
5.	35830B	Presser Foot Shank .....	1
6.	22585R	Screw .....	1
7.	73A	Screw .....	1
8.	35830H	Spring .....	1
9.	22845A	Screw .....	2
10.	22599	Screw .....	1
11.	35830K	Spring .....	1
12.	35830C	Yoke .....	1
13.	C50030AE	Presser Foot Bottom, (front section) FL52-2H72 .....	1
-	C50030AD	Presser Foot Bottom, (front section) FL52-2H64 .....	1
14.	56930	Presser Foot Bottom, (rear section) FL52-2H72 .....	1
-	C50030AC	Presser Foot Bottom, (rear section) FL52-2H64 .....	1
15.	-----	Presser Foot Assy. for sewing comb., FL52-3H32, FL53-3H32, FL52-3H36, FL53-3H36 (see chart) .....	1
16.	21695L	Washer .....	1
17.	21695M	Collar .....	1
18.	21695N	Guard .....	1
19.	35830B	Presser Foot Shank .....	1
20.	22585R	Screw .....	1
21.	73A	Screw .....	1
22.	35830H	Spring .....	1
23.	22845A	Screw .....	1
24.	22599	Screw .....	1
25.	35830K	Spring .....	1
26.	35830C	Yoke .....	1
27.	35830R8	Presser Foot Bottom, (front section) FL52-3H32 .....	1
-	50330BE8	Presser Foot Bottom, (front section) FL53-3H32 .....	1
-	35830R9	Presser Foot Bottom, (front section) FL52-3H36 .....	1
-	35830S9	Presser Foot Bottom, (front section) FL53-3H36 .....	1
28.	50330BF8	Presser Foot Bottom, (rear section) FL52-3H32 .....	1
-	50330BG	Presser Foot Bottom, (rear section) FL53-3H32 .....	1
-	56930	Presser Foot Bottom, (rear section) FL52-3H36 .....	1
-	56930B	Presser Foot Bottom, (rear section) FL53-3H36 .....	1
29.	-----	Feed Dog, FL53-3H32, FL53-3H36 (see chart) .....	1
30.	-----	Feed Dog, FL52-3H32, FL52-3H36 (see chart) .....	1
31.	-----	Feed Dog, FL52-2H64, FL52-2H72 (see chart) .....	1
32.	18-1481	Screw .....	1
33.	-----	Needle Head, FL52-2H64, FL52-2H72 (see chart) .....	1
33A.	-----	Needle Head, FL52-3H32, FL53-3H32, FL52-3H36, FL53-3H36 (see chart) .....	1
34.	SS8080310TP	Screw .....	1
35.	660-1046	Pin .....	1
36.	50618F	Needle Head Eyelet, FL52-2H64 .....	1
-	50618E	Needle Head Eyelet, FL52-2H72 .....	1
36A.	50618D	Needle Head Eyelet, FL52-3H32, FL53-3H32 .....	1
-	50618A	Needle Head Eyelet, FL52-3H36, FL53-3H36 .....	1
37.	2255B7	Screw .....	2
38.	-----	Throat Plate, FL52-2H64, FL52-2H72 (see chart) .....	1
39.	-----	Throat Plate, FL52-3H32, FL52-3H36 (see chart) .....	1
40.	-----	Throat Plate, FL53-3H32, FL53-3H36 (see chart) .....	1
41.	22570	Screw .....	2



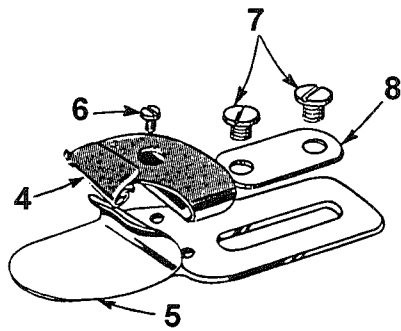
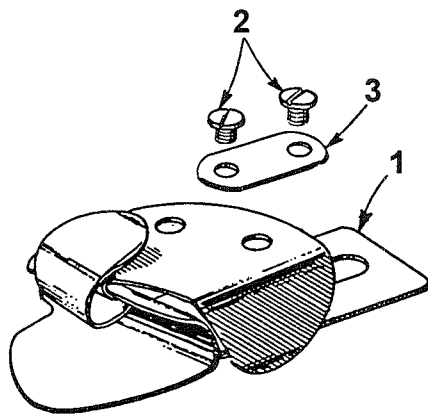

# FOLDERS

Ref. No.	Part No.	Description	Amt. Req.
1.	23420S8-1/8	Folder, for Styles, FL53-3H32 .....	1
-	23420S9-1/8	Folder, for Styles, FL53-3H36 .....	1
-	23420U16-3/32	Folder, for Styles, FL52-3H64 .....	1
2.	25C	Screw .....	2
3.	57864B	Clamp Plate .....	1
4.	23421U16-3/32	Scroll, For Styles, FL52-3H32 .....	1
-	23421U18-3/32	Scroll, For Styles, FL52-3H36, FL52-2H72 .....	1
5.	23422BZ-3/32	Scroll, Lower, For Styles, FL52-3H32, FL52-3H36 .....	1
-	23422U-3/32	Scroll, Lower, For Styles, FL52-2H72 .....	1
6.	28	Screw .....	1
7.	25C	Screw .....	2
8.	57864B	Clamp Plate .....	1

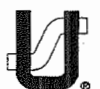

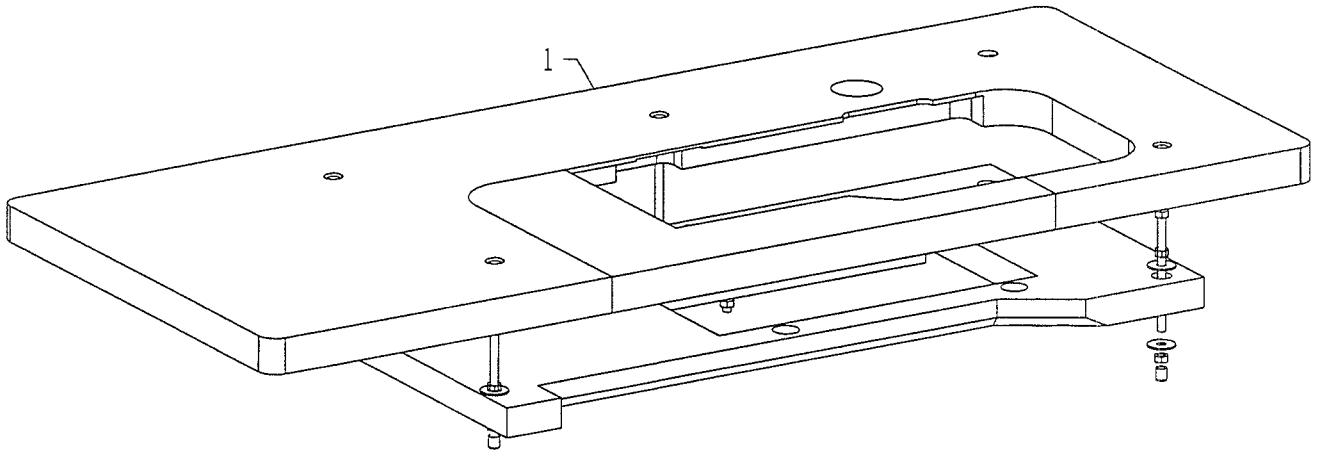

TABLING  
(EXTRA SEND CHARGE)

Ref. No.	Part No.	Description	Amt. Req.
1.	21317AAH48	Table Board, for plain feed machines .....	1



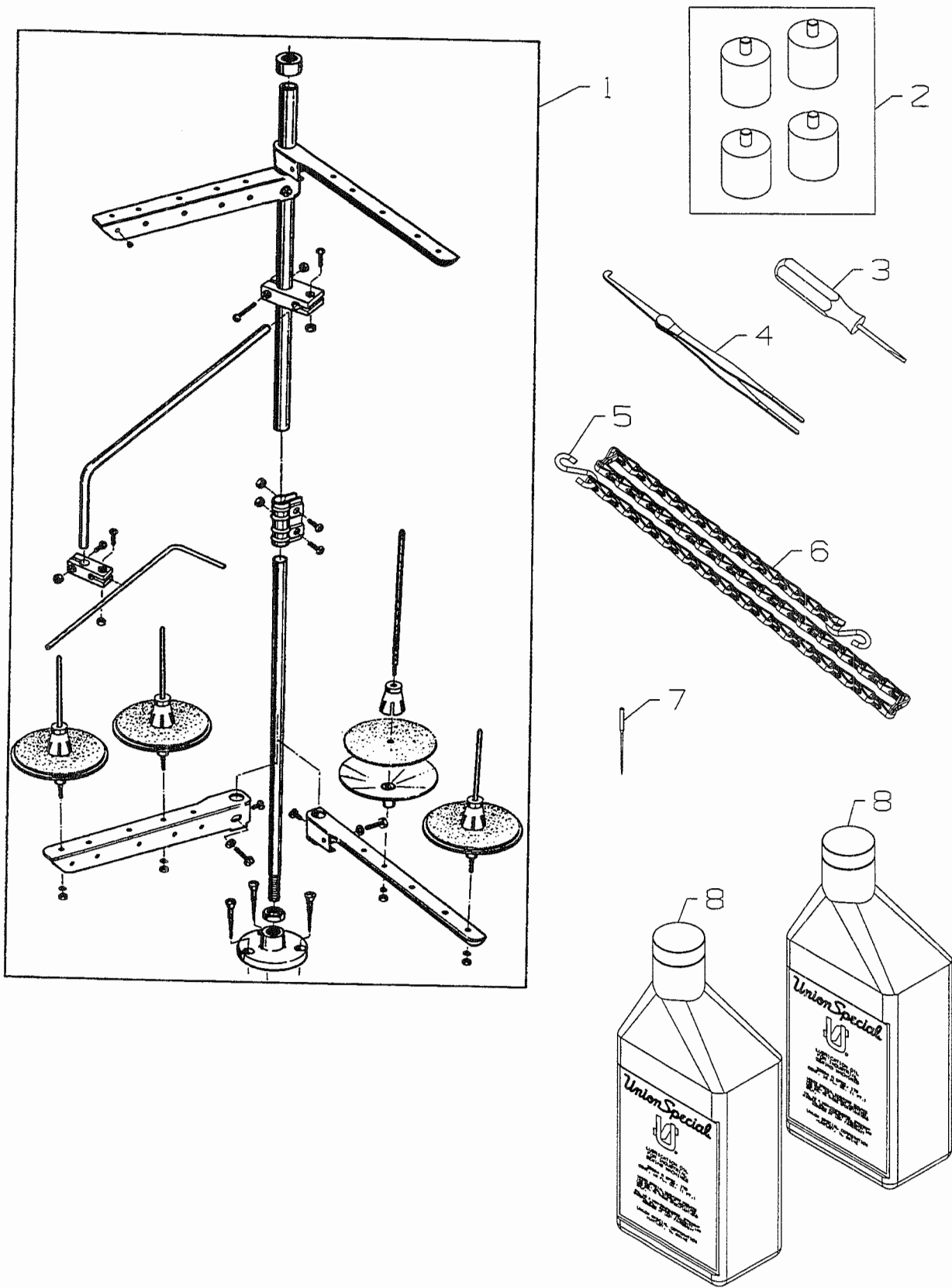

## ACCESSORIES

Ref. No.	Part No.	Description	Amt. Req.
1.	21101W4	Thread Stand (2 Needle) .....	1
-	21101W6	Thread Stand (3 Needle) .....	1
2.	35095B	Isolator .....	4
3.	21201A	Screw Driver, for needle head .....	1
4.	660-240	Thread Tweezer .....	1
5.	660-264	S-Hook .....	2
6.	421D34	Chain .....	1
7.	128GAS140/054	Needles .....	10
8.	28604R	Oil, (1 pint) .....	2



NUMERICAL INDEX OF PARTS

<u>Part No.</u>	<u>Page No.</u>	<u>Part No.</u>	<u>Page No.</u>	<u>Part No.</u>	<u>Page No.</u>	<u>Part No.</u>	<u>Page No.</u>	<u>Part No.</u>	<u>Page No.</u>
11071602	31	2 8	5 7	50332AC	43	50368A	41	50393FU	21
11071701	31	28604R	61	50332B	51	50368E	41	50393FV	37
11550100	29	29126FB	45	50332S	37	50368W	41	50393GB	37
11843208	37	29476TC	23	50332U	21	50370F	27	50393GD	37
128GAS140/054	61	29476TK	31	50332V	31	50373DA	41	50393GE	21
13765607	37	29476TT	31	50333A	35	50374	35	50393HA	51
18-1432	45	29476UF	47	50334A	45	50378S	51	50393HB	33, 51
18-1448	49	29476UH	35	50334BB	47	50380D	49	50393HH	27
18-1481	53, 55	29476UK	43	50334BC	47	50381	31	50393HJ	37
2 0	5 1	29476US	37	50334BD	45	50381B	31	50393HK	37
21101W4	61	29476UT	37	50334W	45	50381E	21	50393HL	37
21101W6	61	29476VN	23	50334Y	45	50381F	31	50393HN	37
21201A	61	34393D	37	50335	47	50381G	31	50393HR	37
21317AAH48	59	35036AE	49	50335A	47	50382CG	51	50393HU	51
21695L	53, 55	35036AZ	47	50335AG	31	50382CJ	51	50393JP	23
21695M	53, 55	35036BS	21	50335AH	31	50382CL	49	50393JW	23
21695N	53, 55	35036F	47	50335AK	35	50382CP	49	50393JZ	23
22-348	43	35095B	61	50335BA	45	50382CR	49	50393KF	37
22513D	51	35569J	51	50335BB	35	50382CS	49	50393KH	37
22517	49	35730AC	53	50335BD	25	50382FP	51	50393KM	37
22517B	33	35730AD	53	50335D	47	50382FW	33	50393W	51
22519J	51	35730AE	53	50336S	47	50382FX	33	50601E	49
2255B7	55	35830B	55	50336Y	47	50382FY	33	50601F	49
22565	39	35830C	55	50337T	47	50382FZ	33	50604	43
22570	53, 55	35830H	55	50338	23	50382GA	33	50605HR	53
22571E	37	35830K	55	50338A	23	50382GB	33	50618A	55
22571L	21	35830R8	55	50342AX	35	50382GM	33	50618D	55
22585R	53	35830R9	55	50342BE	25	50382JR	49	50618E	53, 55
22587N	49	35830S9	55	50342BJ	39	50382T	51	50618F	53, 55
22591A	47	36271A	27	50342BK	39	50383E	43	50622C	41
22596H	47	39250J	51	50342BP	39	50383F	43	50622D	35
22599	55	41358	43	50342BS	35	50383G	51	50622E	35
22637P24	45	421D34	61	50344AM	39	50384	37	50623B	43
22652B10	39	50303B	49	50344BC	21	50384A	37	50625	41
22652J10	39	50304H	43	50344BE	21	50384K	49	50630A64	53
22653J8	39	50304K	43	50344BF	21	50384L	33	50630A72	53
22655B7	53	50313B	39	50344BU	21	50392AB	21	50634	45
22714C	47	50313C	39	50344E	21	50392AV	29	50634C	45
22729D	51	50313J	39	50345W	23	50392BA	27	50634D	45
22799AH	51	50314E	39	50347R	43	50392BC	29	50634E	45
22799C	53	50314F	39	50351A	23	50392V	27	50634G	47
22799G	53	50317B	23	50352	23	50392W	29	50637	45
22839C	49	50317C	33	50354F	23	50392X	29	50637A	45
22841U	51	50321F	25	50355	47	50392Z	29	50640-29	45
22845A	55	50321G	35	50355AM	23	50393-140	37	50642	39
22875N	29	50322AF	25	50355AN	23	50393-170	37	50643	31
22881C	39	50322AG	35	50355AR	31	50393-27	37	50654	21
22894C	43	50322AL	35	50357AE	27	50393-40	37	50654A	21
22894P	47	50322AR	47	50357AN	43	50393-447	37	50657A	43
23420S8-1/8	57	50322BC	25	50357AS	27	50393-70	37	50658A	27
23420S9-1/8	57	50323B	43	50357V	27	50393EB	37	50658B	27, 33
23420U16-3/32	57	50323L	43	50357Y	27	50393EU	33	50663A	27
23421U16-3/32	57	50323P	23	50358H	43	50393EW	33	50666	27
23421U18-3/32	57	50330BE8	55	50358V	27	50393EX	37	50666A	27
23422BZ-3/32	57	50330BF8	55	50358W	27	50393EY	21	50666C	27
23422U-3/32	57	50330BG	55	50358X	23	50393FR	37	50667	51
2 5 C	5 7	50330CZ	21	50366	27	50393FS	37	50668	41
2 5 C C	5 1	50332A	51	50366B	27	50393FT	37	50674	47

