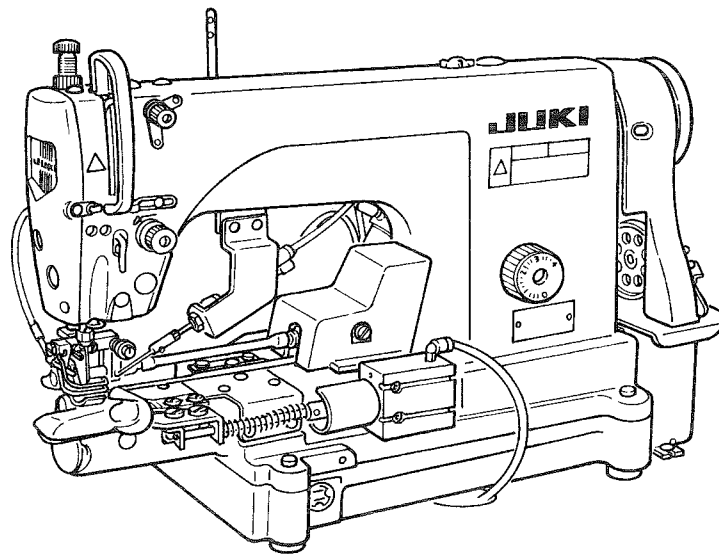

**DLN-6390****DLN-6390-7****取扱説明書****INSTRUCTION MANUAL****MANUEL D'UTILISATION****MANUALE D'ISTRUZIONI****BETRIEBSANLEITUNG****MANUAL DE INSTRUCCIONES****使用説明書**

注意：	このたびは、当社の製品を、お買い上げいただきまして、有難うございました。安全に使用していただくために、使用前に必ずこの取扱説明書をお読みください。また、いつでもすぐに読めるように、この取扱説明書を保管してください。
NOTE：	Read safety instructions carefully and understand them before using. Retain this Instruction Manual for future reference.
HINWEIS：	Lesen Sie die Sicherheitsanweisungen aufmerksam durch, um sich mit ihnen vertraut zu machen, bevor Sie diese Maschine in Betrieb nehmen. Bewahren Sie diese Bedienungsanleitung für spätere Bezugnahme auf.
NOTE：	Avant d'utiliser la machine, lire attentivement toutes les consignes de sécurité. Conserver ce manuel pour pouvoir le consulter en cas de besoin.
NOTA：	Antes de comenzar a usar esta máquina lea con detención hasta comprender todas las instrucciones de seguridad. Conserve este Manual de instrucciones a mano para futuras consultas.
NOTA：	Leggere attentamente e comprendere tutte le istruzioni per la sicurezza prima di iniziare l'uso di questa macchina. Conservare questo Manuale d'Istruzioni per pronto riferimento.
注意：	為了安全地使用，請您在使用之前一定閱讀本使用說明書。 另外，請您注意保管本使用說明書，以便隨時查閱。

***ENGLISH***

***ENGLISH***

## I. SPECIFICATIONS

	DLN-6390-7	DLN-6390
Application	Bottom hemming, waist band attaching (lockstitch type), hemming (lockstitch type)	
Max. sewing speed	When stitch length is less than 3.6 mm : 5,000 rpm When stitch length is not less than 3.6 mm : 4,500 rpm	
Stitch length	2.1*mm, 2.3 mm, 2.5*mm, 2.8 mm, 3.2 mm (standard), 3.6 mm, 4.2*mm * : Optional	
Needle	SCHMETZ UY180GVS Nm140 (shank diameter $\phi$ 1.84) Range of use : Nm90 to #150 (equivalent to #14 to #22.5)	
Needle bar stroke	35 mm	
Thread take-up stroke	123 mm	
Hook	Exclusive automatic lubricating full-rotary 1.7 fold hook	
Lift of presser foot	Presser lifting lever : 4.5 mm	
(Between upper feed roller and lower roller)	Auto-lifter : 13 mm (Max. 14 mm)	Knee lifter (by manual) : 13 mm (Max. 14 mm)
Feed method	Upper/lower roller continuous feed method	
Hemming binder open/close method	Air cylinder drive	By manual
Lubricating oil	New Defrix Oil No. 1	
Stitch length adjusting method	Gear replacement method	
Needle clamp method	Nut clamp method	
Motor	SC-510	400W or higher power clutch motor can be used.
Noise	Workplace-related noise at sewing speed n = 5,000 min <sup>-1</sup> : L <sub>PA</sub> ≤ 84 dB (A) Noise measurement according to DIN 45635-48-A-1.	

## IMPORTANT SAFETY INSTRUCTIONS

Putting sewing systems into operation is prohibited until it has been ascertained that the sewing systems in which these sewing machines will be built into, have conformed with the safety regulations in your country. Technical service for those sewing systems is also prohibited.

1. Observe the basic safety measures, including, but not limited to the following ones, whenever you use the machine.
2. Read all the instructions, including, but not limited to this Instruction Manual before you use the machine. In addition, keep this Instruction Manual so that you may read it at anytime when necessary.
3. Use the machine after it has been ascertained that it conforms with safety rules/standards valid in your country.
4. All safety devices must be in position when the machine is ready for work or in operation. The operation without the specified safety devices is not allowed.
5. This machine shall be operated by appropriately-trained operators.
6. For your personal protection, we recommend that you wear safety glasses.
7. For the following, turn off the power switch or disconnect the power plug of the machine from the receptacle.
  - 7-1 For threading needle(s), looper, spreader etc. and replacing bobbin.
  - 7-2 For replacing part(s) of needle, presser foot, throat plate, looper, spreader, feed dog, needle guard, folder, cloth guide etc.
  - 7-3 For repair work.
  - 7-4 When leaving the working place or when the working place is unattended.
  - 7-5 When using clutch motors without applying brake, it has to be waited until the motor stopped totally.
8. If you should allow oil, grease, etc. used with the machine and devices to come in contact with your eyes or skin or swallow any of such liquid by mistake, immediately wash the contacted areas and consult a medical doctor.

9. Tampering with the live parts and devices, regardless of whether the machine is powered, is prohibited.
10. Repair, remodeling and adjustment works must only be done by appropriately trained technicians or specially skilled personnel. Only spare parts designated by JUKI can be used for repairs.
11. General maintenance and inspection works have to be done by appropriately trained personnel.
12. Repair and maintenance works of electrical components shall be conducted by qualified electric technicians or under the audit and guidance of specially skilled personnel.  
Whenever you find a failure of any of electrical components, immediately stop the machine.
13. Before making repair and maintenance works on the machine equipped with pneumatic parts such as an air cylinder, the air compressor has to be detached from the machine and the compressed air supply has to be cut off. Existing residual air pressure after disconnecting the air compressor from the machine has to be expelled. Exceptions to this are only adjustments and performance checks done by appropriately trained technicians or specially skilled personnel.
14. Periodically clean the machine throughout the period of use.

15. Grounding the machine is always necessary for the normal operation of the machine. The machine has to be operated in an environment that is free from strong noise sources such as high-frequency welder.
16. An appropriate power plug has to be attached to the machine by electric technicians. Power plug has to be connected to a grounded receptacle.

17. The machine is only allowed to be used for the purpose intended. Other used are not allowed.
18. Remodel or modify the machine in accordance with the safety rules/standards while taking all the effective safety measures. JUKI assumes no responsibility for damage caused by remodeling or modification of the machine.

19. Warning hints are marked with the two shown symbols.





Danger of injury to operator or service staff



Items requiring special attention

## FOR SAFE OPERATION

	<ol style="list-style-type: none"><li>1. To prevent accidents caused by electric shock, never open the motor control box cover or touch the components inside the control box while the power switch is ON.</li></ol>
	<ol style="list-style-type: none"><li>1. Never bring your fingers under the needle when the power switch is turned ON or the machine is in operation..</li><li>2. Never bring your fingers, hair or clothes close to the handwheel and needle or place anything on the handwheel and under the needle while the machine is in operation.</li><li>3. Never operate the machine with any of the belt cover, finger guard or safety devices such as eye guard cover, etc. removed.</li><li>4. Be sure to turn OFF the power and perform the work after ascertaining that the sewing machine does not run even when the starting pedal is depressed in case of checking, adjusting, cleaning, threading or replacing the needle of the sewing machine.</li><li>5. Never operate the sewing machine with the ground wire for the power supply removed so as to ensure safety.</li><li>6. Be sure to turn OFF the power switch in advance in case of inserting/removing the power plug.</li><li>7. In time of thunder and lightning, stop your work and disconnect the power plug from the receptacle so as to ensure safety.</li><li>8. When you move the sewing machine from a cold place directly to a warm place, dew condensation may result. Turn ON the power to the machine after you have confirmed that there is no fear of dew condensation.</li><li>9. In case of maintenance, inspection, or repair, be sure to turn OFF the power switch and confirm that the sewing machine and the motor have completely stopped before starting the work. (In case of the clutch motor, it continues rotating for a while by the inertia even after turning OFF the power switch. So, be careful.)</li></ol>

### CAUTION BEFORE OPERATION



#### **WARNING :**

To avoid malfunction and damage of the machine, confirm the following.

- Be sure to fill the oil hole with oil before use.
- Clean the sewing machine thoroughly before using it for the first time.
- Remove all dust collected on the sewing machine during the transportation.
- Confirm that the voltage and phase are correct.
- Confirm that the power plug is properly connected.
- Never use the sewing machine in the state where the voltage type is different from the designated one.
- The direction of rotation of the sewing machine is counterclockwise as observed from the handwheel side. Be careful not to rotate it in reverse direction.
- When operating the sewing machine, turn ON the power switch after properly setting the head on the table.
- For the first month after set-up, use the machine at a reduced sewing speed of 4,000 rpm or less.
- Operate the handwheel after the sewing machine has totally stopped.

# CONTENTS

I. SPECIFICATIONS .....	1
II. INSTALLATION (COMMON TO BOTH MODELS) .....	2
1. Setting the belt .....	3
2. Installing the thread stand .....	3
3. Installing the belt cover, the bobbin winder base and the bobbin winder .....	4
4. Installing the hemming binder .....	5
5. Application of grease .....	6
III. INSTALLATION (DLN-6390-7) .....	6
1. Installing and setting of SC-510 .....	6
2. Wiring the cords .....	7
3. Installing the knee switch .....	8
4. Piping pneumatic components and wiring electric components .....	9
IV. INSTALLATION (DLN-6390) .....	10
1. Selecting the motor pulley and the belt .....	10
2. Installing the motor .....	10
3. Set-up of the hemming binder open/close mechanism .....	11
4. Set-up of the presser foot lifting mechanism .....	12
5. Simultaneous operation of the presser foot lifting and open/close of the hemming binder .....	13
V. LUBRICATION AND DRAINING .....	14
1. Lubrication .....	14
2. Draining .....	14
3. Adjusting the amount of oil .....	15
VI. OPERATION .....	17
1. Attaching the needle .....	17
2. Setting the bobbin into the bobbin case .....	17
3. Threading the machine head .....	18
4. Adjusting the stitch length .....	19
5. Winding the bobbin thread .....	20
6. Thread tension .....	21
7. Thread take-up spring .....	21
8. Adjusting the thread take-up stroke .....	21
VII. ADJUSTING THE SEWING MACHINE .....	22
1. Adjusting the height of the needle bar .....	22
2. Installing position of the hook .....	23
3. Adjusting the needle stop position .....	24
4. Explanation and adjustment of the pedal components .....	24
5. Adjusting the wiper .....	26
6. Hand lifter .....	26
7. Adjusting the presser foot pressure (upper feed roller) and the height of the presser foot (upper feed roller) .....	27
8. Adjusting the presser foot pressure (presser foot (asm.)) and the height of the presser foot (presser foot (asm.)) .....	28
VIII. TROUBLES IN SEWING AND CORRECTIVE MEASURES .....	29
IX. THREAD TRIMMER COMPONENTS .....	32
1. Checking the receding position of the moving knife and the correcting method .....	32
2. Checking the thread trimmer cam timing .....	33
3. Counter knife .....	34
X. SETUP OF OPTIONAL COMPONENTS .....	35
1. Needle cooler .....	35
XI. SETTING OF SC-510 .....	39

## II. INSTALLATION (COMMON TO BOTH MODELS)

< Table >

Arrange the relation of position between the table, motor, pneumatic components, etc. referring to the drawing of table below.

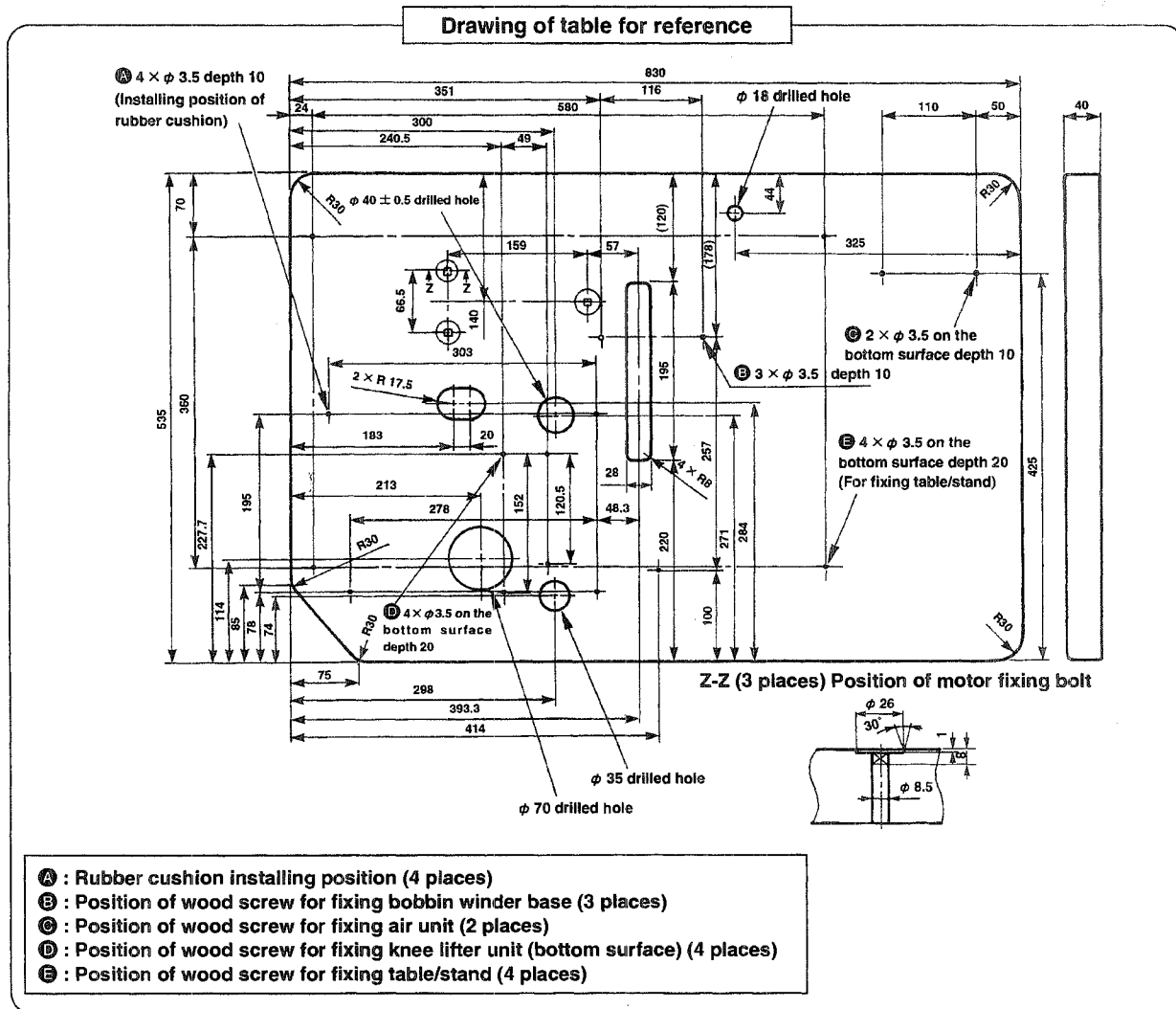

### Fixing of the rubber cushion and set-up of the sewing machine

Fit rubber cushions ① to the wood screws after securely fixing collars ③ onto the top surface of table ④ with wood screws ② (4 places). (For the position, refer to the drawing of table for reference.)

Adjust the concave (4 places) located on the bottom surface of sewing machine ⑤ to rubber cushions ① after securely fixing rubber cushions ① on table ④ and set sewing machine ⑤ on the table.

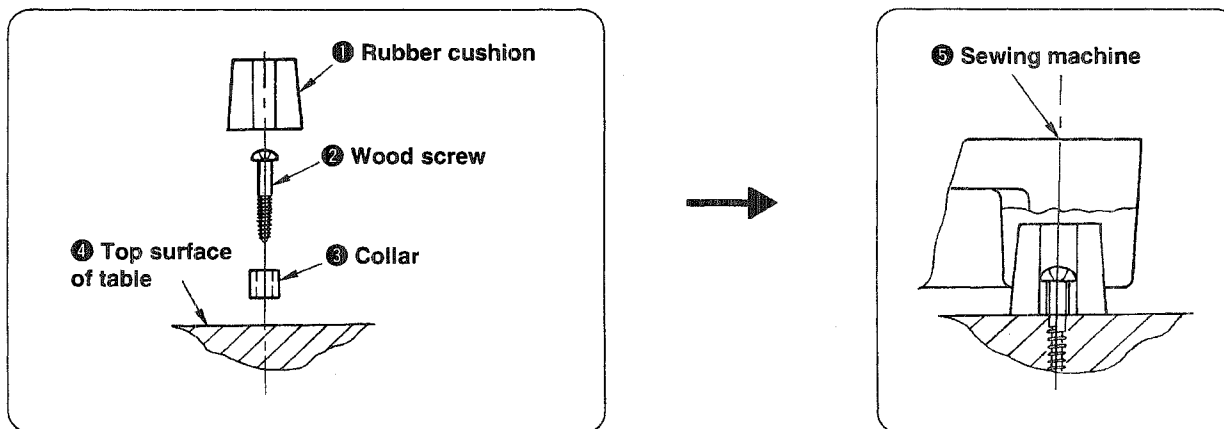

## 1. Setting the belt



### WARNING :

When replacing the belt, be sure to turn OFF the power to the motor and ascertain that the motor has totally stopped rotating before starting the work. There is a danger of injury since hands or clothes may be caught in the belt.

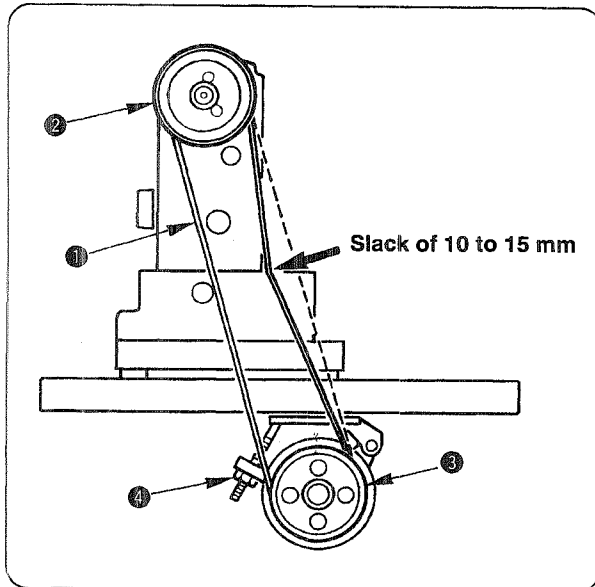

- 1) Fit belt ① to machine pulley ②.
- 2) Turning machine pulley ②, set the other side of the belt to motor pulley ③.
- 3) Adjust the belt tension so that the belt sags 10 to 15 mm when the center of the belt is pressed with an approximate 10 N (1.02 kgf) load.
- 4) Securely fix the belt with lock nut ④ when the belt has been set.



If the deflection of the belt is excessive when the sewing machine is operated, check again the belt tension.

\* After completion of set-up, install the belt cover for motor pulley supplied with the motor in accordance with the Instruction Manual for motor.

## 2. Installing the thread stand

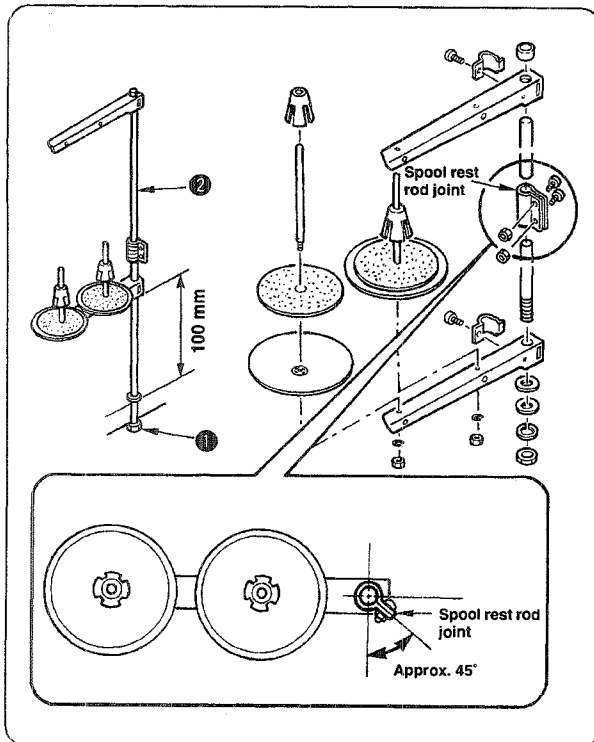

- 1) Assemble the thread stand unit, and insert it in the hole in the machine table.
- 2) Tighten locknut ① to fix the thread stand.
- 3) For ceiling wiring, pass the power cord through spool rest rod ②.



Assemble spool rest rod joint so that it faces in the direction as shown in the figure.

### 3. Installing the belt cover, the bobbin winder base and the bobbinwinder



#### WARNING :

To protect against possible personal injury due to abrupt start of the machine, be sure to start the following work after turning the power off and ascertaining that the motor is at rest.

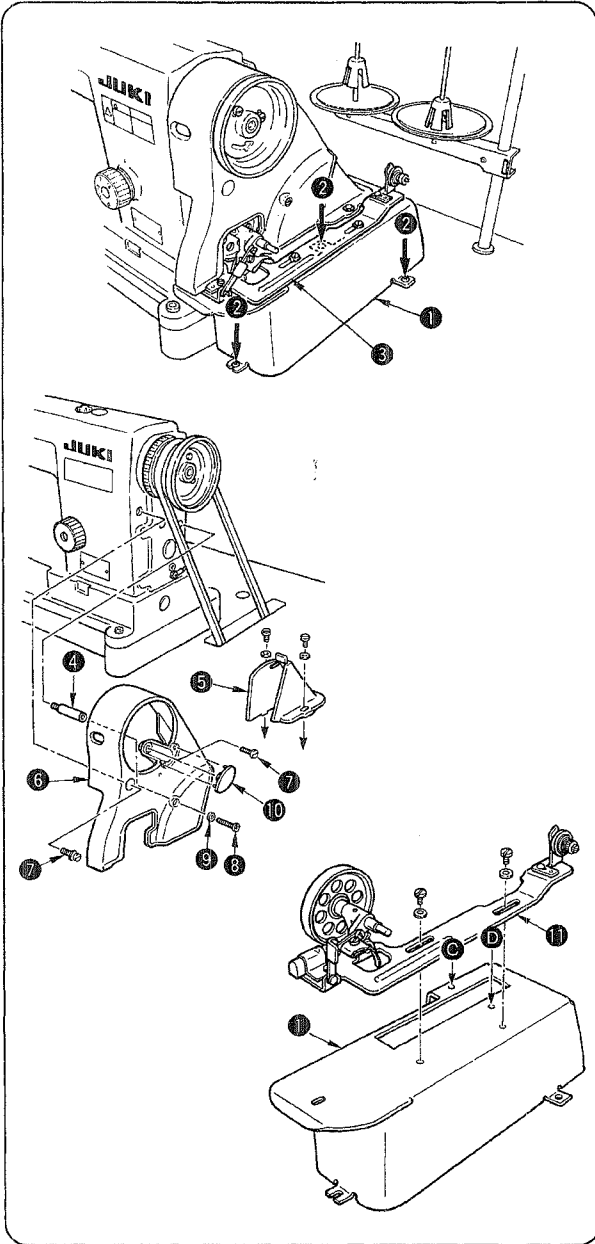

#### <Installation procedure>

- 1) Fix bobbin winder base ① onto the table with wood screws ②. (Wood screws in 3 places)  
(For the fixing position, refer to the drawing of table for reference.)
- 2) Temporarily fix bobbin winder ③ on bobbin winder base ①. (Screw + (plus) washer in 2 places)
- 3) Install belt cover support ④ in the tapped hole in the arm.
- 4) Pass the handwheel through the hole in belt cover A ⑥, then set the handwheel on the arm. At this time, you can smoothly install the belt cover A ⑥ by tilting it from the slant rear side as illustrated in the figure below.
- 5) Place belt cover B ⑤ on tap holes ③ and ④.
- 6) Fix belt cover A ⑥ on the arm using screws ⑦, ⑧ and washer ⑨. At this time, tighten screw ⑦ with a tightening torque of 3 N·m and screw ⑧ with a tightening torque of 2.5 N·m. If you tighten further these screws, the securing state of the belt cover will not change.
- 7) Fit cap ⑩ to the belt cover A.
- 8) Move belt cover B ⑤ backward until the rubber section of belt cover B ⑤ comes in contact with belt cover A ⑥. Then, further move the belt cover B in the same direction by 0.5 to 1 mm. Now, fix the belt cover B in position using screws and washers.
- 9) Adjust the position of bobbin winder ⑪ to a proper one by moving back and forth bobbin winder ⑪ which has been temporarily fixed. Then fix it.

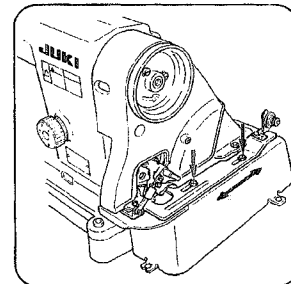
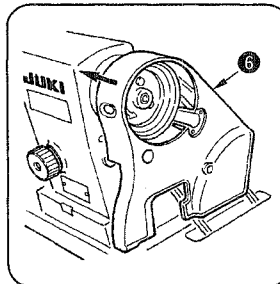

## 4. Installing the hemming binder



### WARNING :

To protect against possible personal injury due to abrupt start of the machine, be sure to start the following work after turning the power off and ascertaining that the motor is at rest.

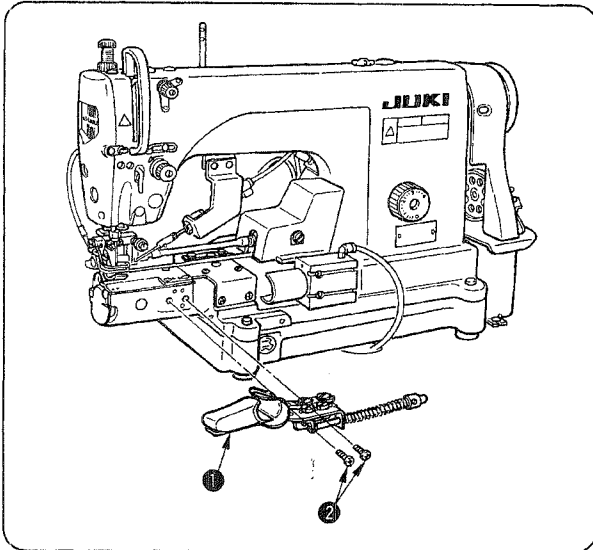

Install hemming binder ① on the sewing machine using setscrews ② (tightening torque : 4 to 6 N·m).

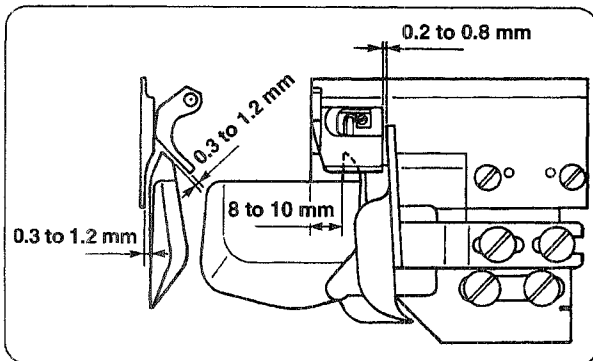

### ■ Standard of installing position

- Vertical position : clearance between left guide section and throat plate : 0.3 to 1.2 mm
- Longitudinal position : clearance between hemming binder and presser : 0.3 to 1.2 mm
- Left guide : 8 to 10 mm from left end of throat plate
- Right guide : clearance between right guide and right end of presser : 0.2 to 0.8 mm
- Assemble the hemming binder so that it is almost parallel to top surface of throat plate and front face of throat plate.

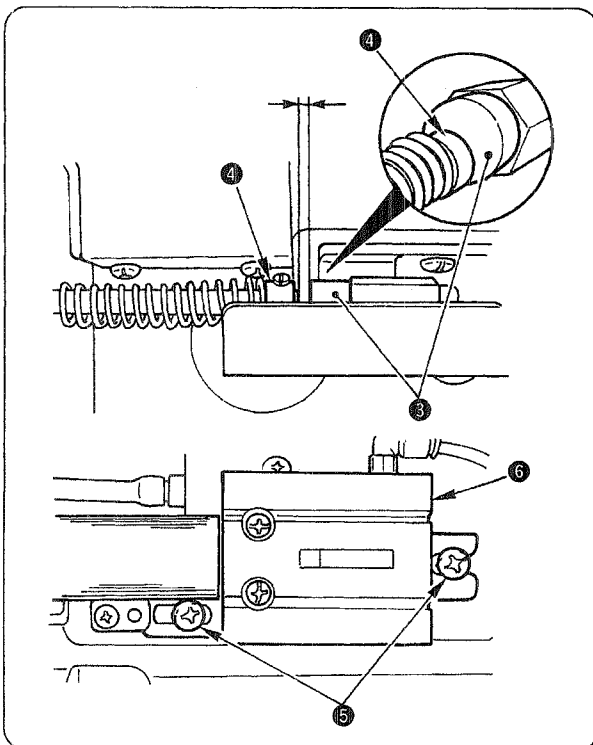

1. Installing position above is the standard installing position. Use the sewing machine after adjusting the installing position to the position where you can handle the binder with ease.



2. Make sure that the sewing machine and the hemming binder do not come in contact with each other at the time of open/close of the hemming binder.

### ■ Adjusting the position between hemming binder and air cylinder (DLN-6390-7)

- Loosen setscrew ⑤ and adjust the lateral position of air cylinder so that the clearance between top end ④ of the hemming binder and top end ③ of the air cylinder is 2 to 3 mm.
- It is not exactly essential that top end ④ of the hemming binder is always in the center against top end ③ of the air cylinder. Use it within the range of appropriate position.

## 5. Application of grease

Apply grease supplied with the machine as accessories (JUKI GREASE A TUBU : 40006323) to the portions as shown in the illustrations below at the time of set-up.

- In case of DLN-6390

Apply grease to hinge screws (\*) of sections A through C and the periphery of the gears of section D when replacing the feed adjusting gears.

- In case of DLN-6390-7

Apply grease only to section D in the illustration when replacing the feed adjusting gears.

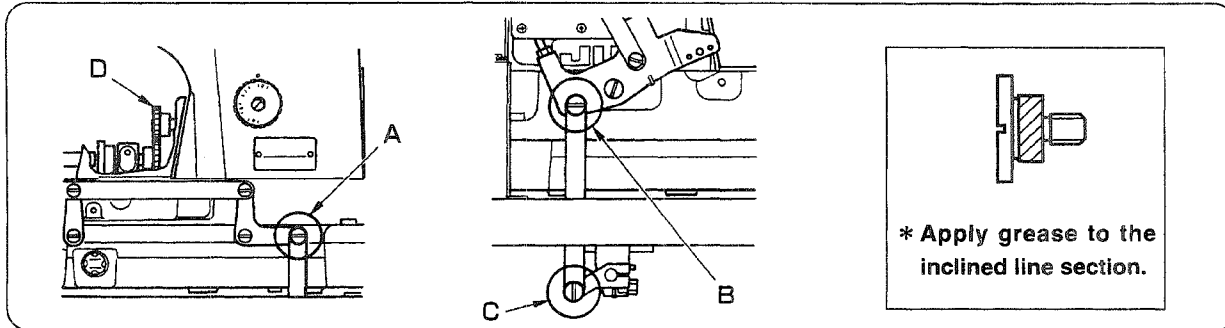

## III. INSTALLATION (DLN-6390-7)

This item is applied only to the case where DLN-6390-7 is used.

### 1. Installing and setting of SC-510

Install the motor and SC-510 referring to the Instruction Manual for SC-510.

For the V-belt and the motor pulley, use those supplied with the sewing machine.

To use SC-510 with DLN-6390-7, it is necessary to set the followings after set-up of SC-510.

- 1) Refer to "III-3 Setting for functions of SC-510" in the INSTRUCTION MANUAL for SC-510, and call the function setting No. 95.

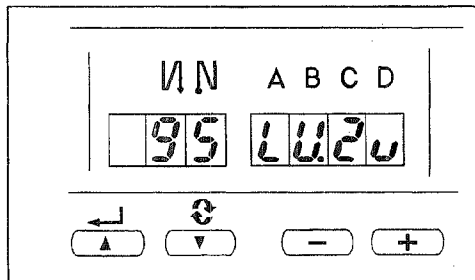

- 2) Select the type of machine head (dLn) by pressing switch ① (switch ②).

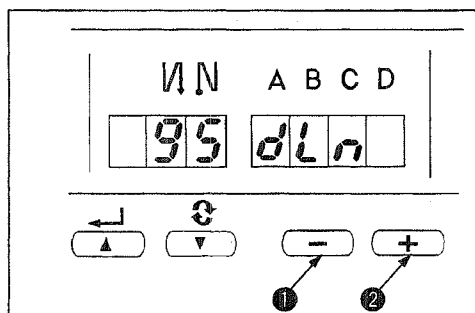

- 3) After determining the type of machine head, by pressing switch ③ (switch ④), the step proceeds to 96 or 94, and the display automatically changes to the contents of the setting corresponding with the type of machine head.

**(Caution)** When the type of machine head is changed, the contents which have been changed before return to the standard set values.

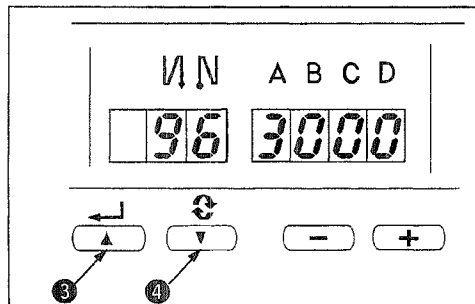

## 2. Wiring the cords

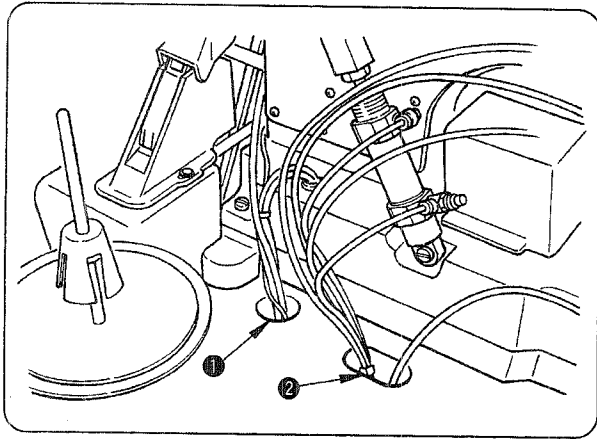

1) After set-up of the sewing machine on the table, pass the cords to the underside of the table through hole ① in the table as shown in the figure.

In addition, pass the air tube which will be laid later through ②.

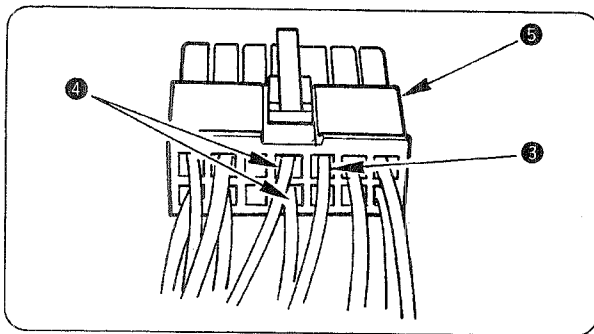

2) Insert the top end of earth cord (asm.) ③ and that of knee switch (asm.) ④ into the positions of connector ⑤ as shown in the figure.

\* There is no designation of color for the cord of the top end of knee switch (asm.) ④ when the inserting place is correct.

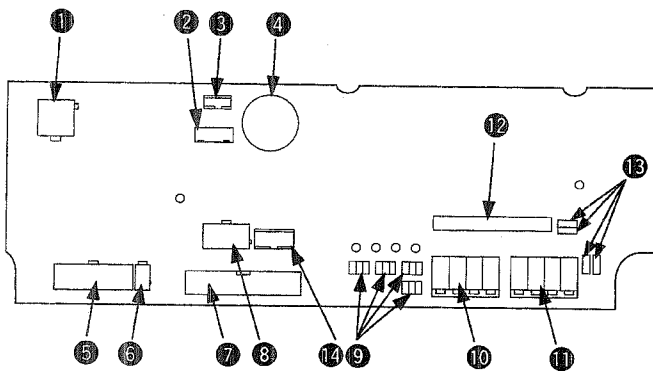

3) Connect the cords of the sewing machine with the cords supplied with the sewing machine as accessories under the table in accordance with the wiring diagram on page 9, and insert them into the connectors located on the inside of the control box of SC-510.

For the details, refer to the INSTRUCTION MANUAL for SC-510.

- ① CN30 Motor signal connector
- ② CN43 Needle bar position detector connector (+12V type)
- ③ CN32 Machine head connector
- ④ CN33 Needle bar position detector connector (+5V type)
- ⑤ CN36 Machine head solenoid connector
- ⑥ CN37 Presser foot lifter solenoid connector
- ⑦ CN38 CP-160 panel connector
- ⑧ CN40 Signal for extension output connector (For the details, refer to Engineer's Manual.)
- ⑨ W1, W2,  
W3, W4 Optional jumper pins for changeover of input/output of power source (For the details, refer to Engineer's Manual.)
- ⑩ CN50 Optional output connector (For the details, refer to Engineer's Manual.)
- ⑪ CN51 Optional input connector (For the details, refer to Engineer's Manual.)
- ⑫ CN41 Connector for extension p.c.b. (For the details, refer to Engineer's Manual.)
- ⑬ W5 to W8 Jumpers for optional input changeover (For the details, refer to Engineer's Manual.)
- ⑭ CN39 Pedal for standing work connector (PK-70 and the like can be used.)

### 3. Installing the knee switch

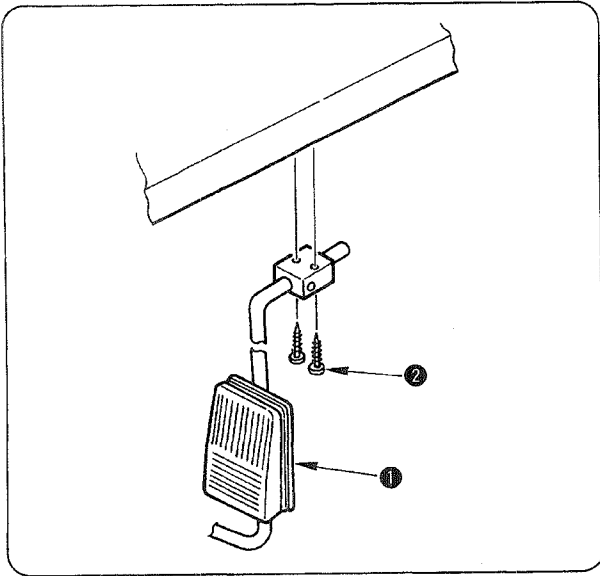

- 1) Fix knee switch ① supplied with the swing machine as accessories to the position you desire to install at the bottom surface of the machine table with wood screws ②.

(For wiring, refer to the item "III-2. Wiring the cord".)

## 4. Piping pneumatic components and wiring electric components

Perform piping of the pneumatic components and wiring of the electric components in accordance with the drawing below.

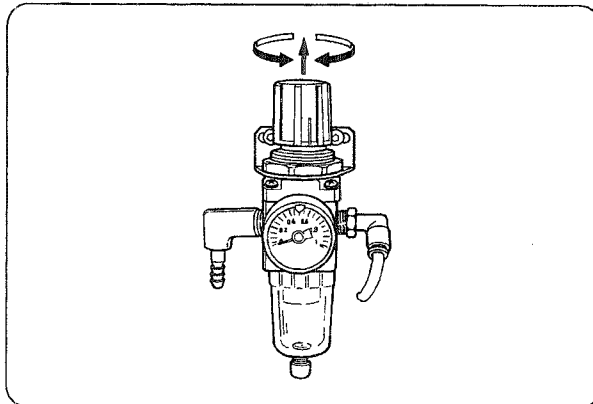
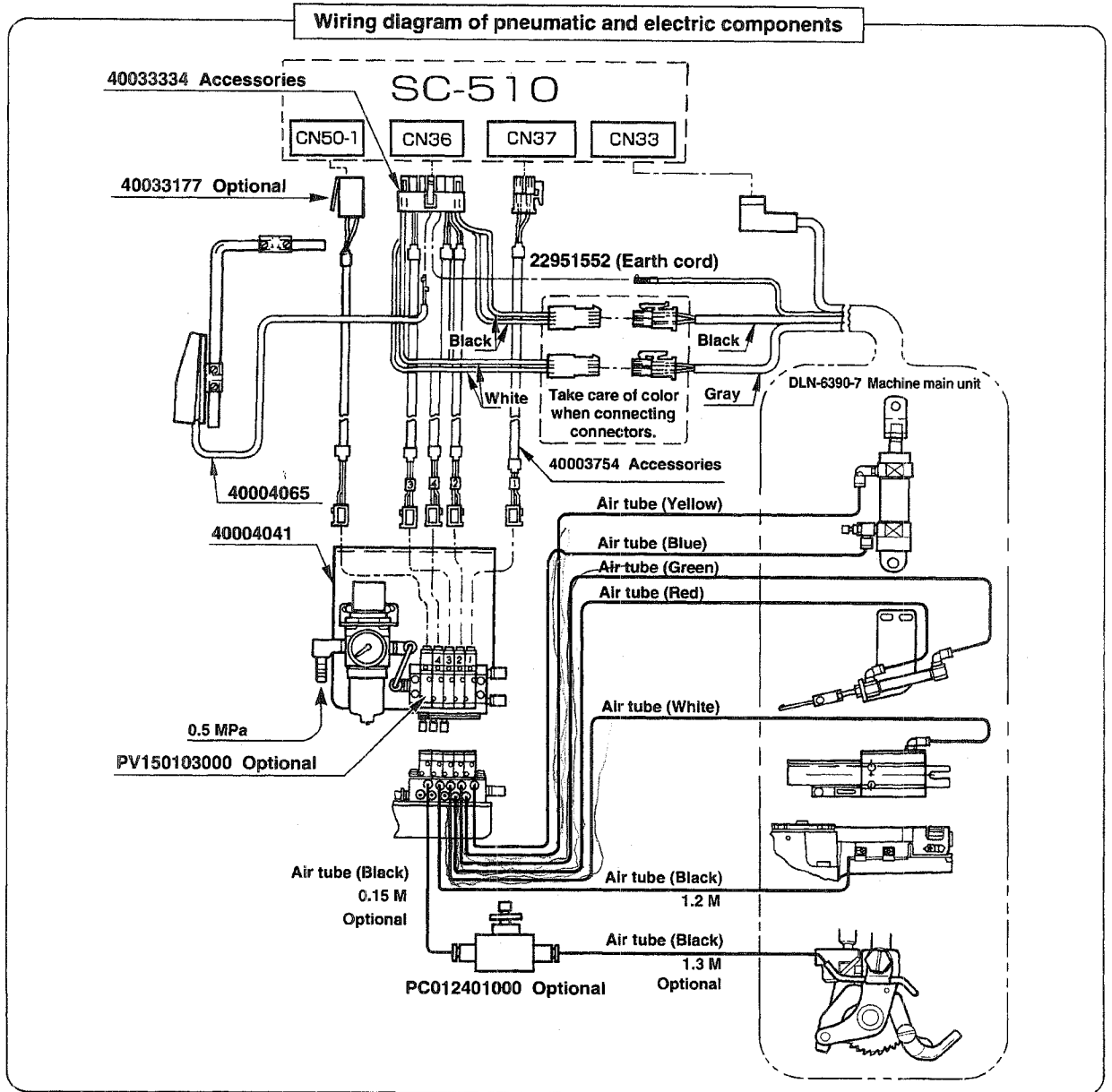

Air pressure required for this sewing machine is 0.5 MPa. Turn the dial to adjust the pressure to 0.5 MPa after completion of piping.

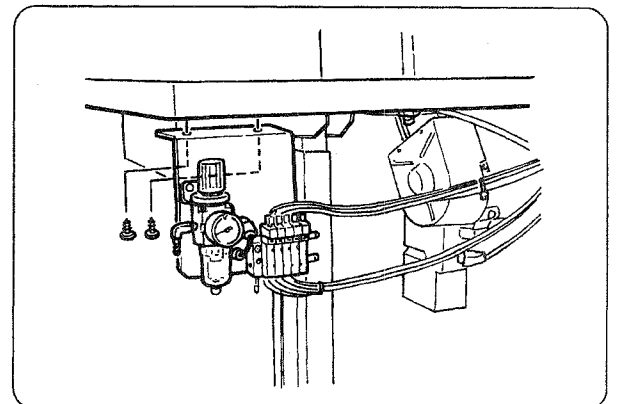

Fix the air unit on the table with wood screws. (For the fixing position, refer to the drawing of table for reference.)

## IV. INSTALLATION (DLN-6390)

This item is applied only to the case where DLN-6390 is used.

### 1. Selecting the motor pulley and the belt

Max. sewing speed of this sewing machine is 5,000 rpm (normal speed : 4,500 rpm). However, when stitch length is 3.6 mm or more, max. sewing speed is 4,500 rpm. Select the optimum motor pulley referring to the table below.

\* Use the HM type V belt.

- 1) Use a clutch motor with an output of 400 W (1/2 HP) as the standard.
- 2) Relation among the motor pulley, belt length and sewing speed of the sewing machine is as shown in the table below.

Outside diameter of motor pulley (mm)	Part No. of motor pulley	Sewing speed (rpm)		Belt length mm (inch)	Part No. of belt
		50 Hz	60 Hz		
125	MTKP0120000	5,060		1321 (52)	MTJVH005200
120	MTKP0115000	4,850		1295 (51)	MTJVH005100
115	MTKP0110000	4,630			
110	MTKP0105000	4,440			
105	MTKP0100000	4,250	5,040	1270 (50)	MTJVH005000
100	MTKP0095000	4,000	4,780		
95	MTKP0090000	3,820	4,540		
90	MTKP0085000	3,610	4,320		
85	MTKP0080000	3,390	4,000		
80	MTKP0075000	3,160	3,790	1245 (49)	MTJVH004900
75	MTKP0070000	2,950	3,520		
70	MTKP0065000	2,740	3,260		

- Effective diameter of the motor pulley is obtained by subtracting 5 mm from the outside diameter.
- Direction of rotation of the motor is counterclockwise as observed from the pulley. Take care not to allow the pulley to turn in the reverse direction.
- When the aforementioned motor pulley and the belt are used, the chain connecting the pedal and the presser foot lifting mechanism may interfere with the motor due to the kind of the motor. In this case, change the length of the aforementioned belt and adjust the position of the motor to the position where the motor does not interfere with the chain.

### 2. Installing the motor

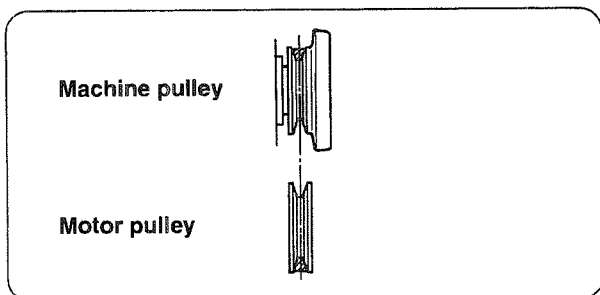

- 1) The motor pulley shifts to the left-hand side when depressing the pedal. At this time, install the motor so that the centers of motor pulley and machine pulley align with each other.

\* For the installing procedure of the motor pulley, refer to the Instruction Manual for motor.

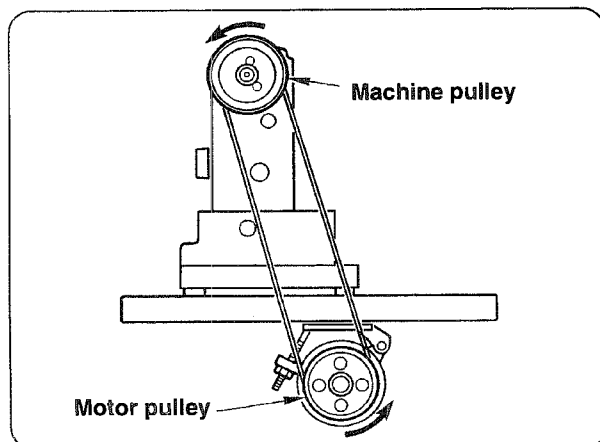

- 2) Install the motor so that the machine pulley rotates counterclockwise.



**If the machine pulley rotates in the reverse direction, normal lubrication cannot be performed. As a result, machine trouble will be caused.**

### 3. Set-up of the hemming binder open/close mechanism



**WARNING :**

To protect against possible personal injury due to abrupt start of the machine, be sure to start the following work after turning the power off and ascertaining that the motor is at rest.

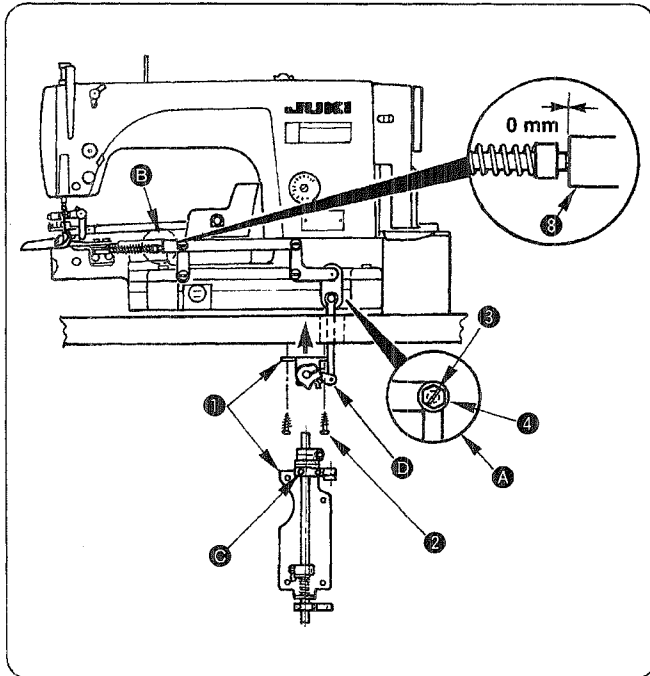

- 1) Fix knee lifter unit ① on the table with wood screws ② (4 pcs.).  
(For the position of the wood screw, refer to the drawing of table for reference.)
- 2) Tighten hinge screw ④ as shown in ⑥.  
(At this time, use nut ③ from the reverse side.)
- 3) Loosen setscrew ⑤ and adjust the angle of arm ⑥ so that the clearance between the top end of hemming binder in section ⑦ and hemming binder actuating rod A ⑧ is "0".

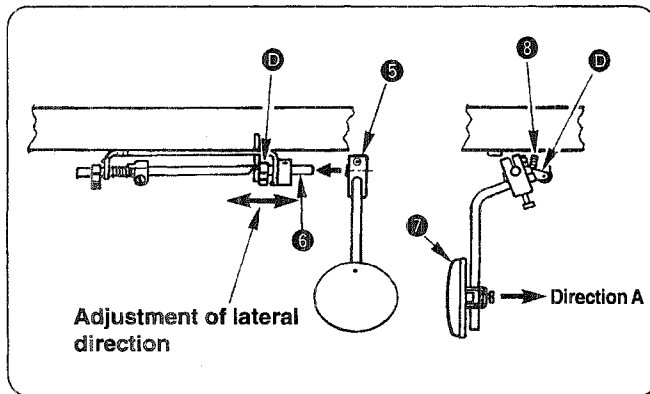

- 4) Set ⑤ to shaft ⑥ fix it at the optimum position.  
Push ⑦ in the direction A and check that the hemming binder (asm.) is smoothly opened/closed.  
(If not, adjust the lateral direction of ⑥.)

\* Max. open/close amount of the hemming binder open/close mechanism is 13 mm.  
Adjust the protruding amount of stopper screw ⑧ and set the open/close amount you desire to obtain within the range of the amount not exceeding max. open/close amount of 13 mm.

#### 4. Set-up of the presser foot lifting mechanism



#### WARNING :

To protect against possible personal injury due to abrupt start of the machine, be sure to start the following work after turning the power off and ascertaining that the motor is at rest.

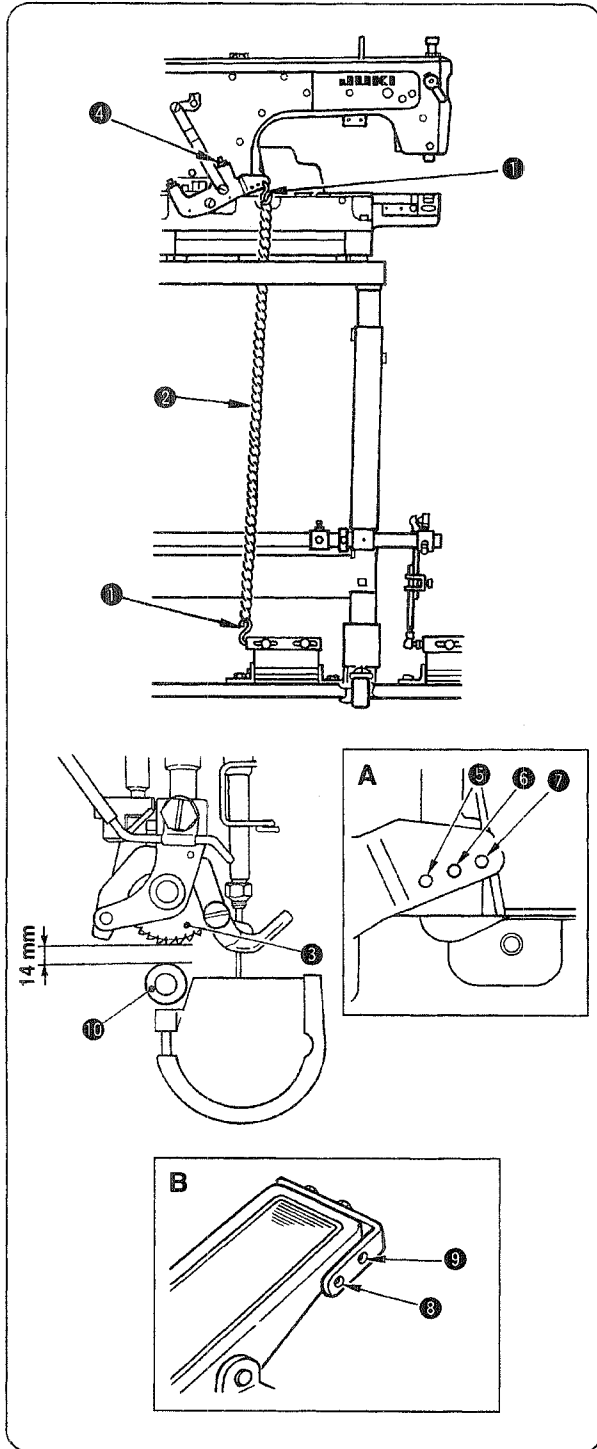

- 1) Hook S shaped hook ① and chain ② supplied with the machine as accessories in the holes of sections A and B.

Check that upper roller ③ is not floated in the state that the foot is kept apart from the pedal.

When it is floated, adjust the length of the chain, and slightly sag the chain.

- 2) Adjust the hooking position of the S shaped hook so that the pedal is placed at the position where the operator can use it with ease. (Section A : ⑤ to ⑦, Section B : ⑧ and ⑨)

\* Lifting amount of the upper feed roller is 14 mm. Adjust the protruding amount of stopper screw ④ and set the lifting amount you desire within the range where the dimension from upper feed roller ③ to lower roller ⑩ does not exceed 14 mm.

## 5. Simultaneous operation of the presser foot lifting and open/close of the hemming binder



### WARNING :

To protect against possible personal injury due to abrupt start of the machine, be sure to start the following work after turning the power off and ascertaining that the motor is at rest.

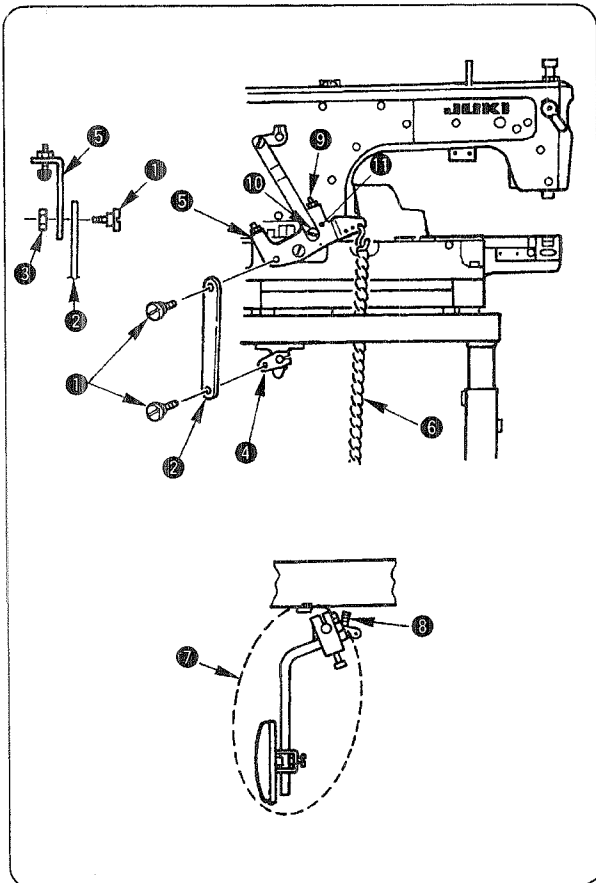

Presser foot lifting and open/close of the hemming binder can be simultaneously performed by attaching the components supplied with the sewing machine as accessories.

- 1) Fix hemming binder connecting rod ② to presser lifting link connection ⑤ and knee lifter lever A ④ using hinge screws ①. (Tightening torque : 4.5 to 5.5 N·m)
- 2) Fix ⑤ on the rear side of hinge screw ① using nut ③. (Tightening torque : 4.5 to 5.5 N·m)

\* When simultaneously performing presser foot lifting and open/close of the hemming binder by knee operation, remove chain ⑥ for use.

When simultaneously performing presser foot lifting and open/close of the hemming binder by pedal operation, remove knee pad plate (asm.) ⑦ for use.

\* When the lifting amount of the upper feed roller is insufficient, move hinge screw ⑩ to ⑪. The lifting amount of the upper feed roller increased with the same operating amount.

\* Lifting amount of the upper feed roller is max. 14 mm and open/close amount of the hemming binder is max. 13 mm. Adjust presser lifting stopper A ⑨ or ⑬ for use so that both the lifting amount of the upper feed roller and the open/close amount of the hemming binder do not exceed the respective max. values.

## V. LUBRICATION AND DRAINING

### 1. Lubrication



#### WARNING :

To protect against possible personal injury due to abrupt start of the machine, be sure to start the following work after turning the power off and ascertaining that the motor is at rest.

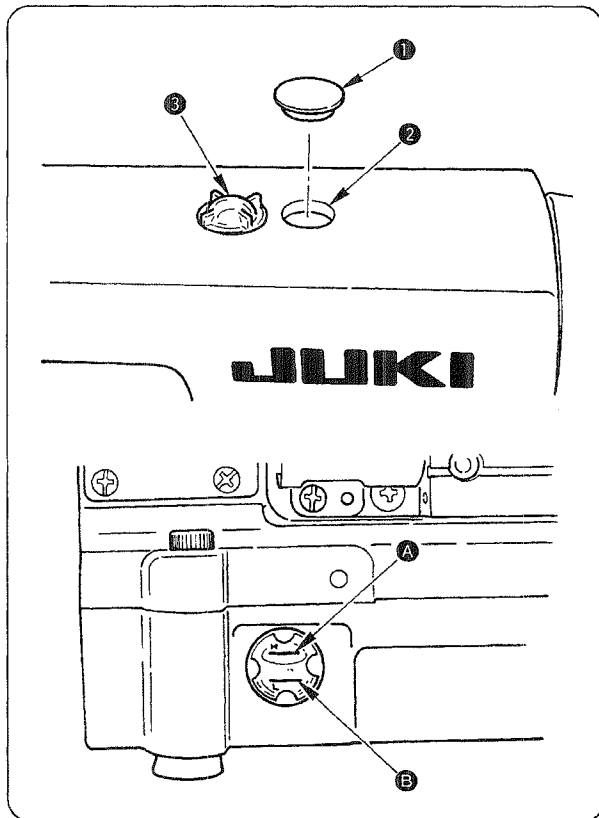

#### (1) Information on lubrication

- 1) Remove cap ① and fill the oil reservoir through oiling inlet ② with JUKI New Defrix Oil No. 1 up to H mark ④. (Standard : 500 cc)
- 2) When the oil level lowers below L mark ⑤, refill the oil reservoir with the specified oil.
- 3) When you operate the machine after lubrication, you will see splashing oil through oil sight window ③ if the lubrication is adequate.
- 4) Note that the amount of the splashing oil is unrelated to the amount of the lubricating oil.



When you first operate your machine after setup or after an extended period of disuse, run your machine at 3,000 rpm to 3,500 rpm. for about 10 minutes for the purpose of break-in.

### 2. Draining

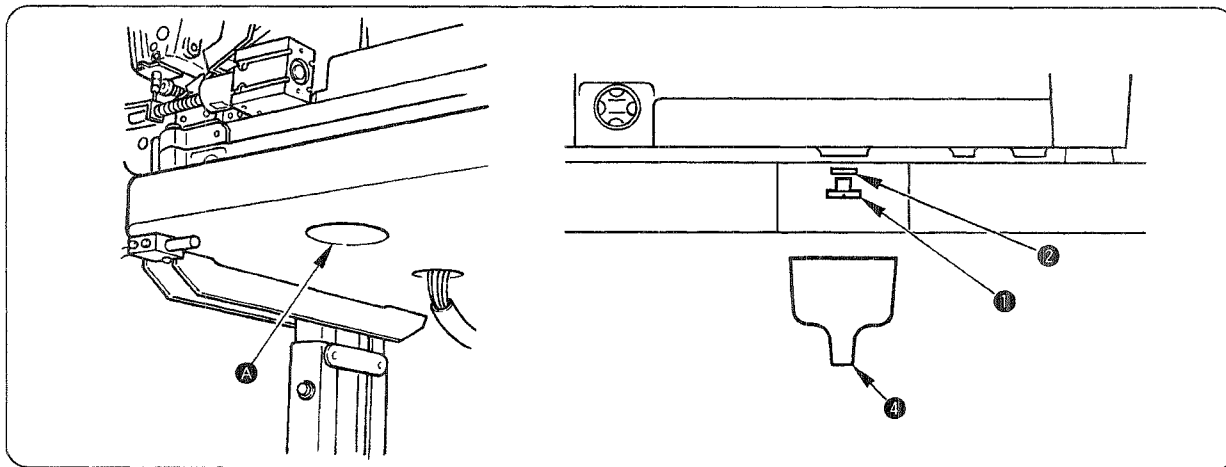

Remove screw ① from hole ④ located at the bottom surface of the table by using a screwdriver to drain oil existing the inside of the sewing machine.

It is convenient to use funnel ④ supplied with the machine.

\* There is O ring ② between screw ① and oil reservoir ③. Take care so as not to lose it.

### 3. Adjusting the amount of oil

#### (1) Adjusting the amount of oil supplied to the face plate parts



#### WARNING :

The sewing machine is running at a high speed. Be extremely careful about the operation of the machine when adjusting the amount of oil to avoid personal injuries.

#### • Checking the amount of oil

##### Position to confirm the amount of oil (oil splashes)

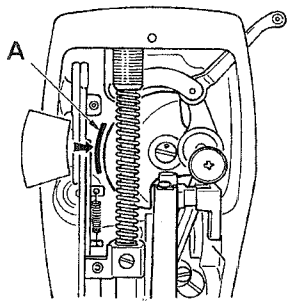

##### Amount of oil (oil splashes) confirmation paper

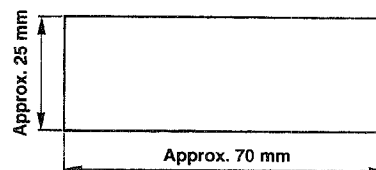

\* Use any paper available regardless of the material.

\* Be extremely careful when carrying out the procedure described below in 2).

- 1) If the machine has not been sufficiently warmed up for operation, make the machine run idle for approximately three minutes. (Moderate intermittent operation)
- 2) Place the amount of oil (oil splashes) confirmation paper under the hook while the sewing machine is in operation. (Section A in the direction of the arrow mark (→))
- 3) Confirm that the height of the oil surface in the oil reservoir is within the range between "H" and "L".
- 4) Confirmation of the amount of oil should be completed in ten seconds. (Check the period of time with a watch.)

#### • Sample showing the appropriate amount of oil (oil splashes) in the face plate parts

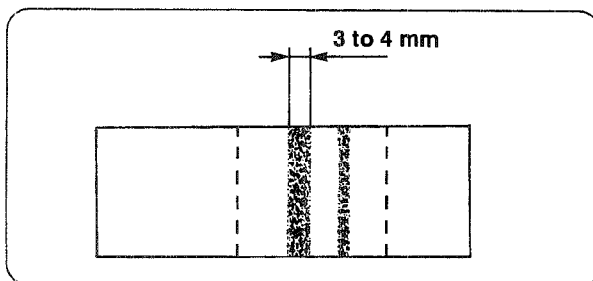

- 1) The sample shown in the figure on the left side is the amount of oil adjusted at the time of delivery. Check the amount of oil before using and adjust the amount of oil to that as shown in the figure on the left.
- 2) Adjust the amount of oil so that the amount of oil (oil splashes) should not change while checking the amount of oil three times (on the three sheets of paper).

#### • Adjusting the amount of oil (oil splashes) in the face plate parts



#### WARNING :

To protect against possible personal injury due to abrupt start of the machine, be sure to start the following work after turning the power off and ascertaining that the motor is at rest.

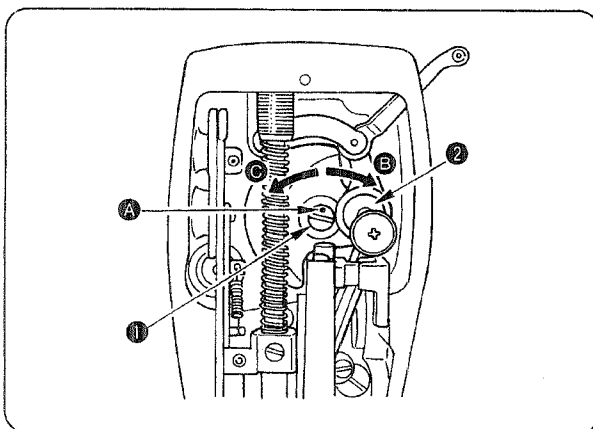

- 1) Adjust the amount of oil supplied to the thread take-up and needle bar crank ② by turning adjust pin ①.
- 2) The minimum amount of oil is reached when marker dot ①A is brought close to needle bar crank ② by turning the adjust pin in direction ③B.
- 3) The maximum amount of oil is reached when marker dot ①A is brought to the position just opposite from the needle bar crank by turning the adjust pin in direction ③C.

(2) Adjusting the amount of oil in the hook



**WARNING :**

Be extremely careful about the operation of the machine since the amount of oil has to be checked by turning the hook at a high speed.

① Amount of oil (oil splashes) confirmation paper

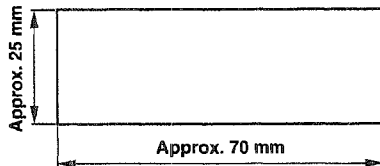

② Position to confirm the amount of oil (oil splashes)

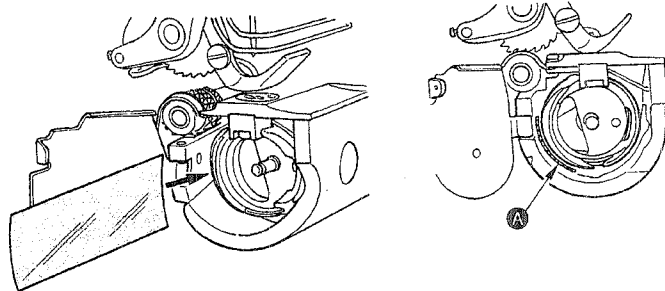

\* Use any paper available regardless of the material.

\* When carrying out the procedure described below in 2), take extreme caution not to allow your fingers to come in contact with the hook.

- 1) If the machine has not been sufficiently warmed up for operation, make the machine run idle for approximately three minutes. (Moderate intermittent operation)
- 2) Place the amount of oil (oil splashes) confirmation paper under the hook while the sewing machine is in operation. (Section A in the direction of the arrow mark (→))
- 3) Confirm that the height of the oil surface in the oil reservoir is within the range between "H" and "L".
- 4) Confirmation of the amount of oil should be completed in five seconds. (Check the period of time with a watch.)

• Sample showing the appropriate amount of oil

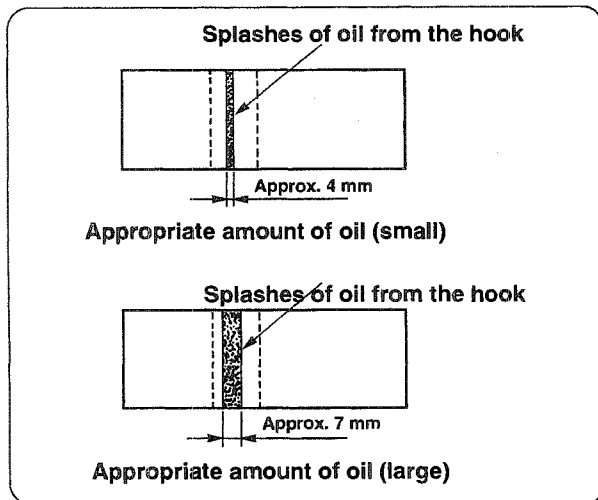

- 1) The amount of oil shown in the samples on the left should be finely adjusted in accordance with sewing processes. Be careful not to excessively increase/decrease the amount of oil in the hook. (If the amount of oil is too small, the hook will be seized (the hook will be hot). If the amount of oil is too much, the sewing product may be stained with oil.)
- 2) Adjust the amount of oil in the hook so that the oil amount (oil splashes) should not change while checking the oil amount three times (on the three sheets of paper).

• Adjusting the amount of oil (oil spots) in the hook

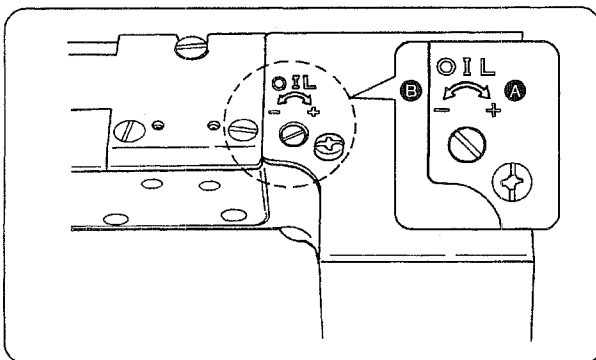

- 1) Turning the oil amount adjustment screw in the "+" direction (in direction A) will increase the amount of oil (oil spots) in the hook, or in the "-" direction (in direction B) will decrease it.
- 2) After the amount of oil in the hook has been properly adjusted with the oil amount adjustment screw, make the sewing machine run idle for approximately 30 seconds to check the amount of oil in the hook.

## VI. OPERATION

### 1. Attaching the needle



#### WARNING :

To protect against possible personal injury due to abrupt start of the machine, be sure to start the following work after turning the power off and ascertaining that the motor is at rest.

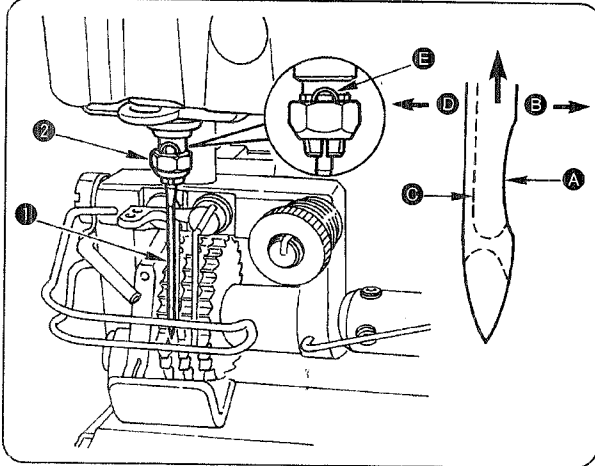

A needle of SCHMETZ UY180GVS should be used. Select a proper needle size from among various sizes according to the count of thread and the type of material used.

- 1) Turn the handwheel until the needle reaches the highest point of its stroke.
- 2) Loosen needle clamp nut ②, and hold needle ① with its indented part ① facing exactly right in direction ②.
- 3) Insert the needle fully into the hole in the needle bar in the direction of the arrow mark until end ⑤ of the hole is reached.
- 4) Securely tighten needle clamp nut ②.
- 5) Check that long groove ③ of the needle is facing exactly to the left in direction ④.

### 2. Setting the bobbin into the bobbin case

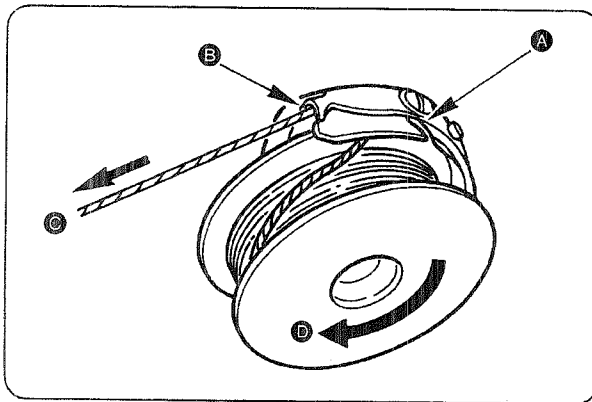

- 1) Pass the thread through thread slit ①, and pull the thread in direction ②. By so doing, the thread will pass under the tension spring and come out from notch ③.
- 2) Check that the bobbin rotates in the direction of the arrow mark ④ when bobbin thread ③ is pulled.
- 3) Securely insert the bobbin case into the hook until the end of the hook is reached in the state that bobbin thread is pulled out approximately 20 mm from the bobbin case.

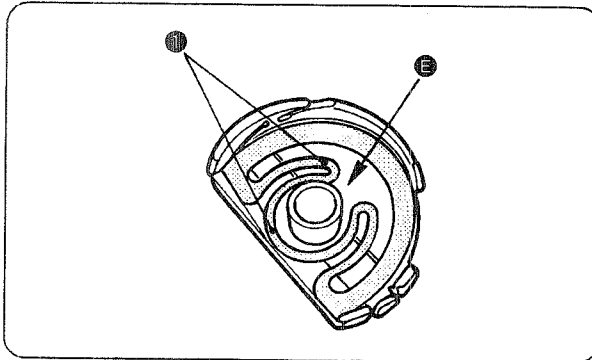

- \* When the idling amount of the bobbin is excessive at the time of thread trimming, raise idle-protection spring ① in the bobbin case and adjust the idling amount within the range where the sewing is not affected.



When waste thread or cloth dust infiltrates in section ③ (between bobbin case and bobbin), unexpected sewing trouble will be caused. Remove waste thread or cloth dust gathered inside the bobbin periodically when replacing the bobbin or the like.



When sewing is performed in the state that the bobbin case is not securely inserted into the hook, unexpected troubles may be caused. When setting the bobbin case to the hook at the time of replacement of bobbin or the like, securely insert the bobbin case into the hook until the end of the hook is reached.

### 3. Threading the machine head



**WARNING :**

To protect against possible personal injury due to abrupt start of the machine, be sure to start the following work after turning the power off and ascertaining that the motor is at rest. If threading is wrong, stitch skipping, thread breakage or irregular stitches will be caused.

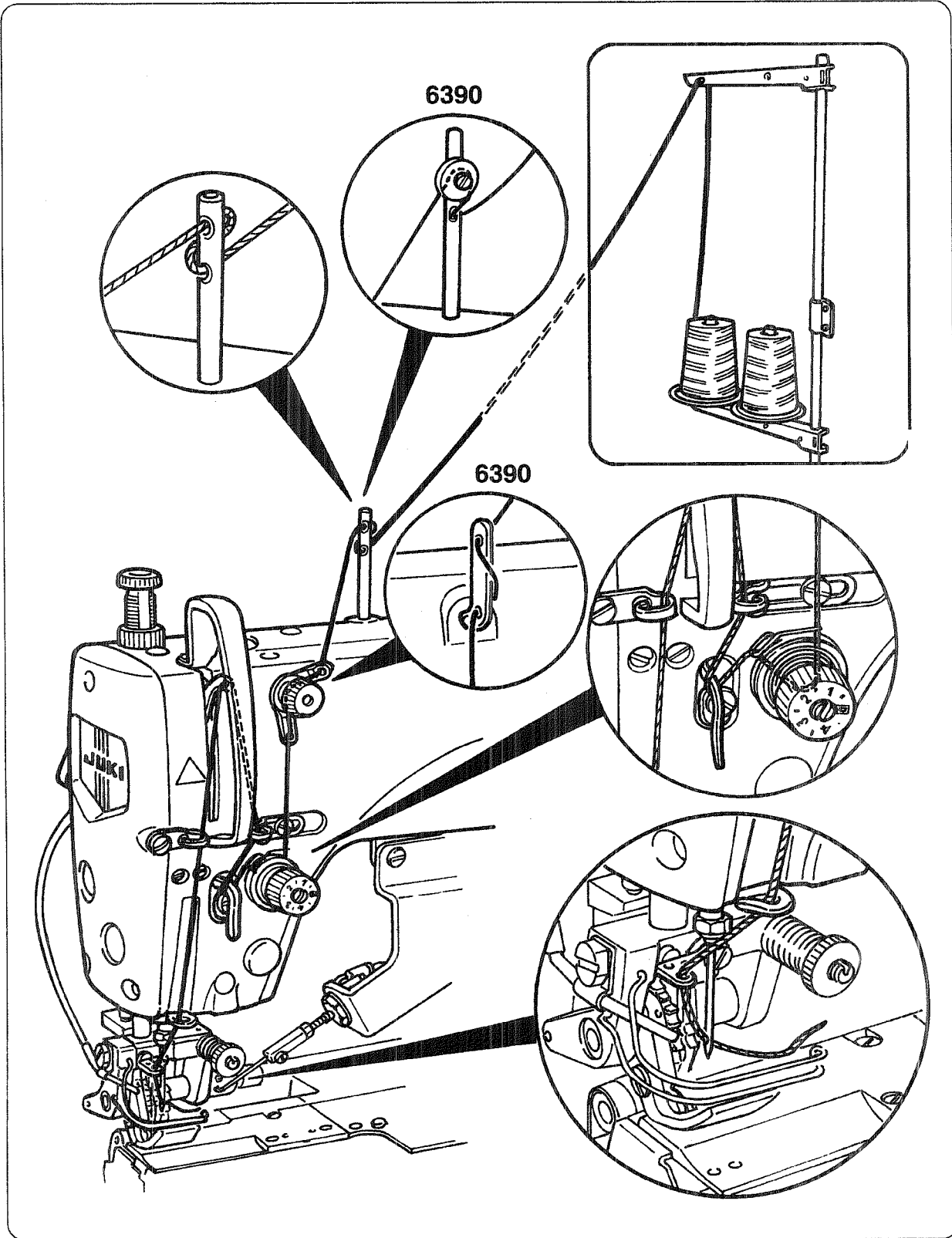

## 4. Adjusting the stitch length



### WARNING :

To protect against possible personal injury due to abrupt start of the machine, be sure to start the following work after turning the power off and ascertaining that the motor is at rest.

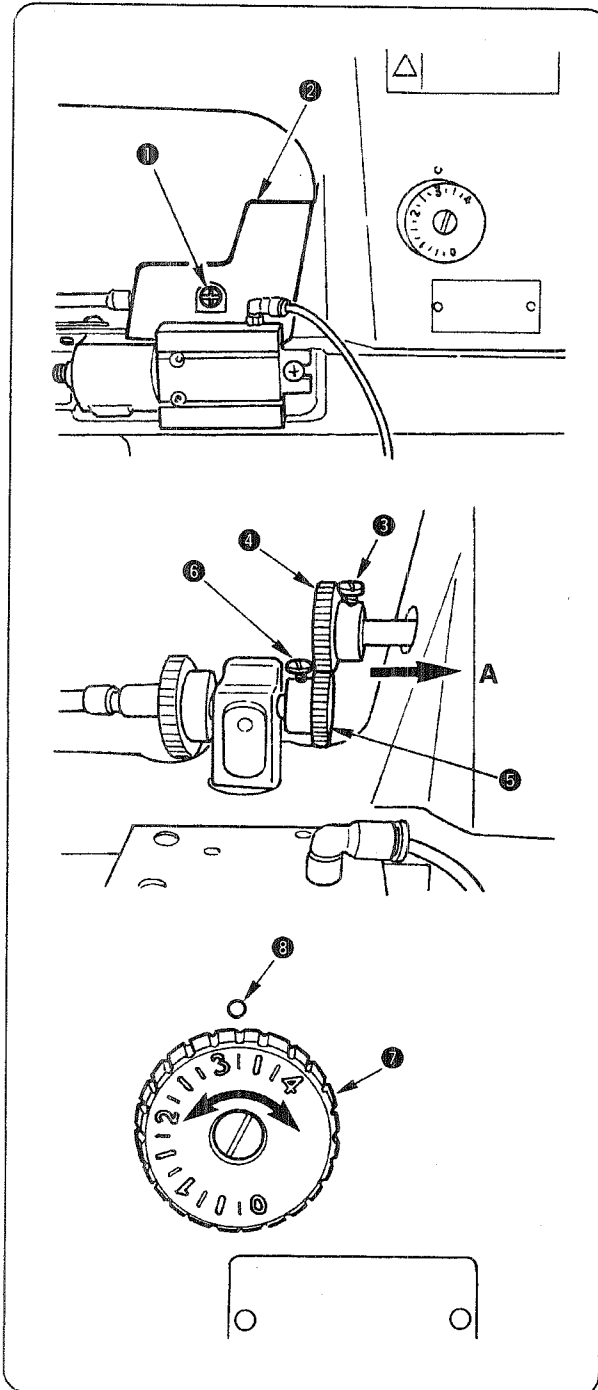

Simultaneously perform procedures ① and ② below to change the stitch length.

- ① Change of needle feed amount : Turning of the feed dial
- ② Change of cloth feed amount : Replacement of the feed amount adjusting gear

Be sure to adjust the scale of the feed dial to the stitch length which has been set with the cloth feed amount adjusting gear for operation.

Perform the procedures below to change the stitch length.

#### <Change of cloth feed amount>

- 1) Remove screw ① and remove cover ②.
- \* Remove cover ② in the rear direction.
- 2) Loosen screw ③ and remove U-Gear ④.
- 3) Loosen screw ⑥ and remove L-Gear ⑤.
- 4) Select from the table below the "Gear" corresponding to the stitch length to be changed.
- \* There is a pitch indication seal showing the relation between the gear and the stitch length in the accessory box. Paste it at the position you desire and refer to it when replacing the gear.
- 5) Fully push U-Gear ④ corresponding to the stitch length to be changed in the direction A until the end is reached, and tighten screw ③. (Tightening torque : 3 to 5 N·m)
- 6) In the state that the presser foot is lowered, adjust L-Gear ⑤ corresponding to the stitch length to be changed to the end plane of U-Gear ④ to determine the position, and tighten screw ⑥ to fix it. (Tightening torque : 3 to 5 N·m)



**When the position of L-Gear ⑤ in terms of U-Gear ④ is slipped, unexpected trouble will be caused. So, be careful.**

#### <Change of needle feed amount>

- 7) Adjust the scale of feed dial ⑦ adjusted to the stitch length corresponding to a set of gears (U-Gear and L-Gear) which has been replaced to dot ⑧ engraved on the sewing machine.
- \* When stitch length is changed to a small one, needle thread may slip off the needle at the start of sewing. In this case, change the setting of SC-510 from "soft-start 1st stitch" to "2nd stitch". For the details, refer to the Instruction Manual for SC-510.



1. Be sure to adjust the scale of feed dial to the needle feed amount corresponding to the cloth feed amount of the selected gears. If the cloth feed amount is different from the needle feed amount, unexpected trouble will be caused.
2. As a matter of convenience, the scale of stitch length dial is indicated up to "0". However, the minimum stitch length of this sewing machine is 2.1 mm. Do not set the scale of the feed dial to less than 2.1 mm.

Pitch	U-Gear marking	JUKI Part No.	L-Gear marking	JUKI Part No.	Remarks
2.1 mm (12-stitch/inch)	63949-33	30037501	63949-47	30037600	Optional
2.3 mm (11-stitch/inch)	63949-36	30037402	63949-44	30037303	Accessories
2.5 mm (10-stitch/inch)	63949-37	30033104	63949-43	30033401	Optional
2.8 mm (9-stitch/inch)	63949-39	30033203	63949-41	30033302	Replace the standard U-Gear with the standard L-Gear.
3.2 mm (8-stitch/inch)	63949-41	30033302	63949-39	30033203	Standard
3.6 mm (7-stitch/inch)	63949-44	30037303	63949-36	30037402	Accessories
4.2 mm (6-stitch/inch)	63949-47	30037600	63949-33	30037501	Optional

## 5. Winding the bobbin thread

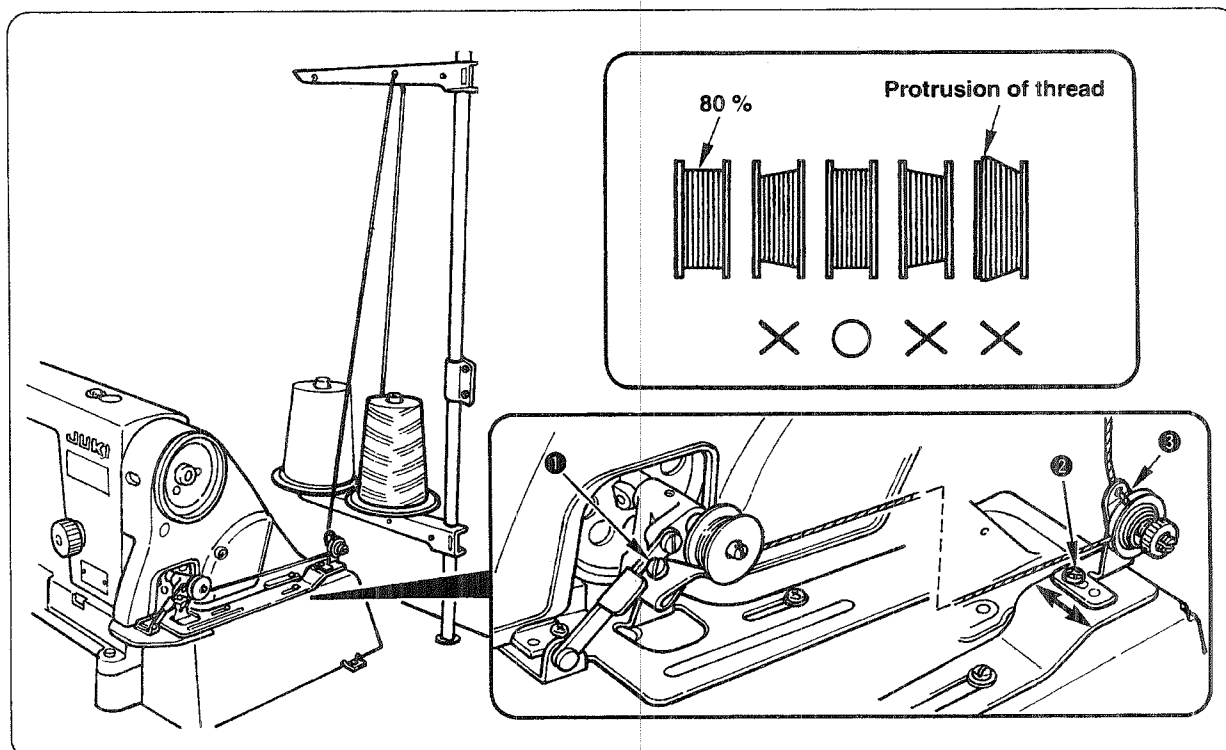

Perform threading the bobbin winder as shown in the figure.

- 1) Adjust screw ❶ so that the winding amount of bobbin should be 80%.  
(The percentage is regarded as 100% when the thread is wound up to the outer diameter of bobbin.)
- 2) When there is uneven winding of the bobbin, loosen screw ❷ and move ❸ in the direction of the arrow mark to adjust so that there is no uneven winding.



**When uneven winding of bobbin is especially excessive, the bobbin with thread protruded from the outer diameter is set to the sewing machine and unexpected sewing trouble may be caused.**

## 6. Thread tension

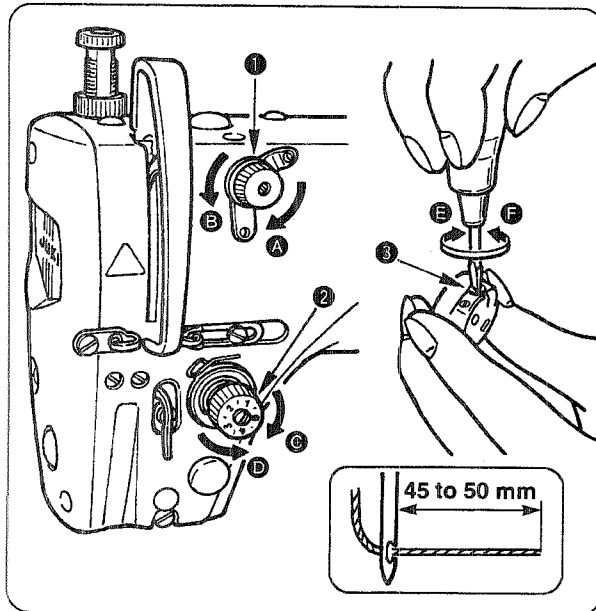

### (1) Adjusting the needle thread tension

- 1) As you turn thread tension No. 1 nut ① clockwise (in direction ①), the thread remaining on the needle after thread trimming will be shorter.
  - 2) As you turn nut ① counterclockwise (in direction ②), the thread length will be longer.
- \* Adjust so that the length of the thread remaining on the needle should be 45 to 50 mm within the range where the thread between the thread tension No. 1 ① and the thread tension ② does not move violently.
- 3) As you turn thread tension nut ② clockwise (in direction ③), the needle thread tension will be increased.
  - 4) As you turn nut ② counterclockwise (in direction ④), the needle thread tension will be decreased.

### (2) Adjusting the bobbin thread tension

- 1) As you turn tension adjust screw ③ clockwise (in direction ⑤), the bobbin thread tension will be increased.
- 2) As you turn screw ③ counterclockwise (in direction ⑥), the bobbin thread tension will be decreased.

## 7. Thread take-up spring

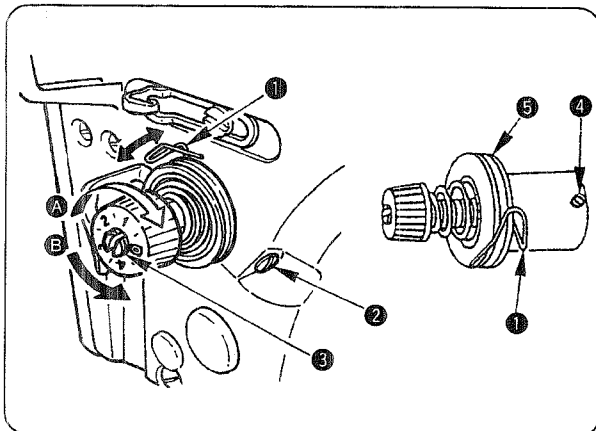

### (1) Changing the stroke of thread take-up spring ①

- 1) Loosen setscrew ②.
- 2) As you turn tension post ③ clockwise (in direction ①), the stroke of the thread take-up spring will be increased.
- 3) As you turn the knob counterclockwise (in direction ②), the stroke will be decreased.

### (2) Changing the pressure of thread take-up spring ①

- 1) Loosen setscrew ②, and remove thread tension (asm.) ⑤.
- 2) Loosen setscrew ④.
- 3) As you turn tension post ③ clockwise (in direction ①), the pressure will be increased.
- 4) As you turn the tension post ③ counterclockwise (in direction ②), the pressure will be decreased.

## 8. Adjusting the thread take-up stroke



### WARNING :

To protect against possible personal injury due to abrupt start of the machine, be sure to start the following work after turning the power off and ascertaining that the motor is at rest.

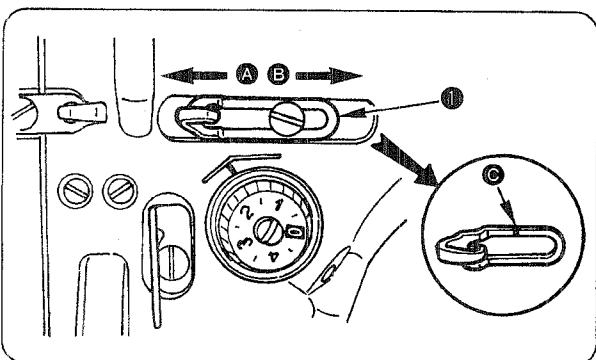

- 1) When sewing heavy-weight materials, move thread guide ① to the left (in direction ①) to increase the length of thread pulled out by the thread take-up.
- 2) When sewing light-weight materials, move thread guide ① to the right (in direction ②) to decrease the length of thread pulled out by the thread take-up.
- 3) Normally, thread guide ① is positioned in a way that marker line ③ is aligned with the center of the screw.

## VII. ADJUSTING THE SEWING MACHINE

### 1. Adjusting the height of the needle bar



#### WARNING :

To protect against possible personal injury due to abrupt start of the machine, be sure to start the following work after turning the power off and ascertaining that the motor is at rest.

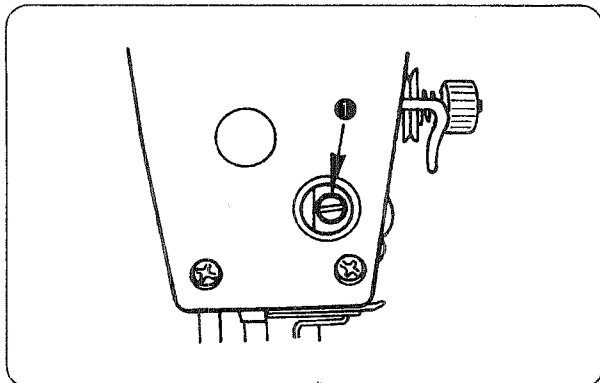

- 1) Turn the handwheel to bring the needle bar to the lowest position of its stroke, and loosen setscrew ① in the needle bar clamp.

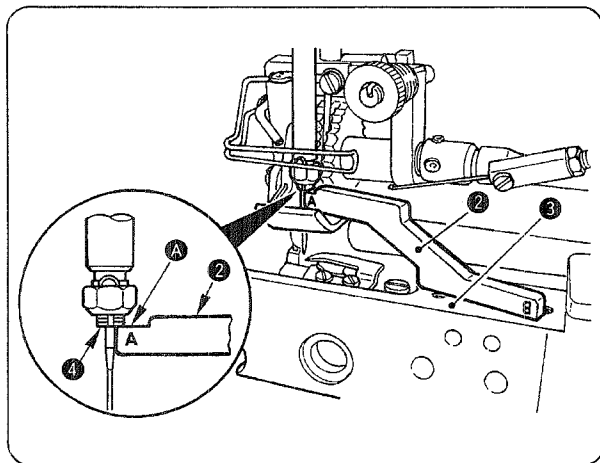

- 2) Set gauge for the height of needle bar ② supplied as accessories to installing plane ③ of the throat plate as shown in the figure, make bottom end ④ of the needle bar come in contact with plane A (section A of engraved marker) of gauge for the height of needle bar ②, and tighten setscrew ① in the needle bar clamp.

## 2. Installing position of the hook



### WARNING :

To protect against possible personal injury due to abrupt start of the machine, be sure to start the following work after turning the power off and ascertaining that the motor is at rest.

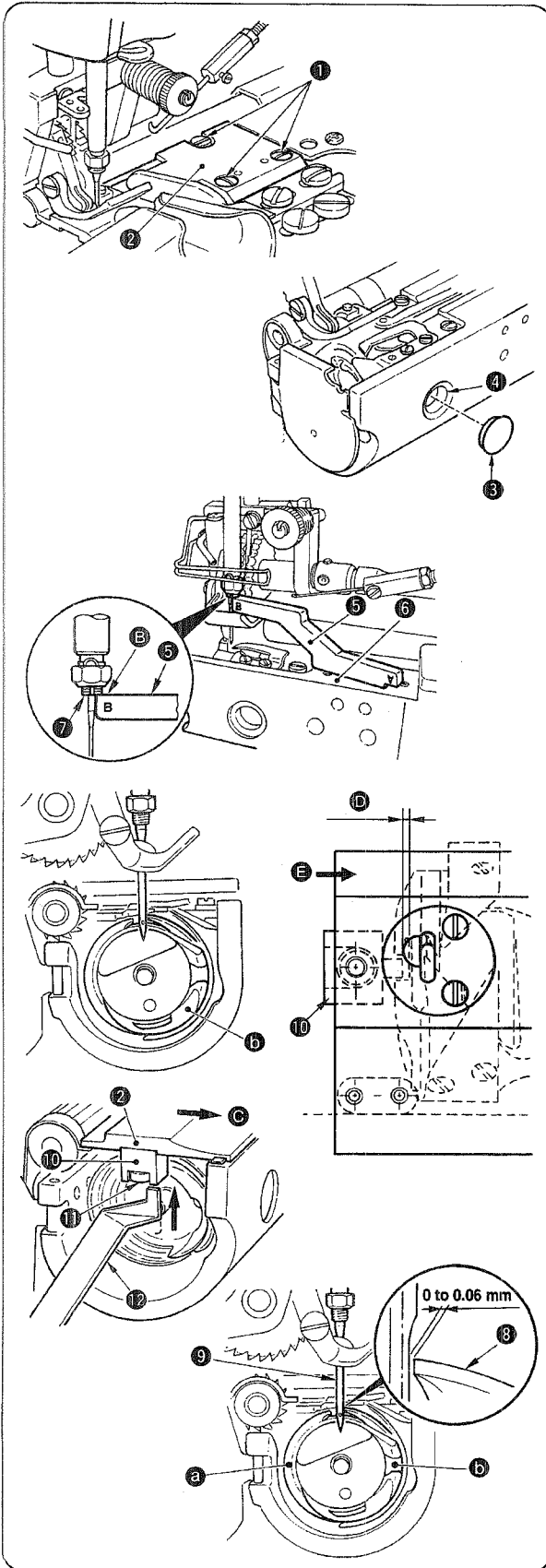

- 1) Remove setscrews ① and remove throat plate ②.
- 2) Remove cap ③ and put a screwdriver from hole ④ to loosen three hook setscrews. Turn the handwheel in the direction where needle bar goes up, set gauge for the height of needle bar ⑤ supplied as accessories to installing plane ⑥ of the throat plate as shown in the figure, and adjust the position so that plane ⑥ (section B of engraved marker) of gauge for the height of needle bar ⑤ enters bottom end ⑦ of the needle bar.
- 3) In this state, adjust blade point ⑧ of hook ③ to the center of needle ⑨. Then adjust so that the clearance provided between the needle and the hook is 0 to 0.06 mm (standard) and securely tighten three hook setscrews. (Tightening torque : 2 to 4 N·m)
  - \* At this time, adjust inner hook ⑤ at the position as shown in the figure.
- 4) Install cap ③ and throat plate ②, and securely tighten setscrews ①. (Tightening torque : 1.5 to 3 N·m)
  - \* Adjust the convex of bobbin case holder ⑩ to the concave of inner hook ⑤ when installing the throat plate.
  - \* Tighten setscrews ① and install throat plate ② while pushing throat plate ② by hand in the direction of arrow mark ③ when installing throat plate ②.
- 5) Adjust clearance ④ provided between the convex of bobbin case holder and the concave of the inner hook with gauge ⑫ supplied with the sewing machine as accessories. (Standard : 0.8 mm)
  - \* Put gauge ⑫ supplied as accessories in clearance ④ and tighten setscrew ⑪ while lightly pushing bobbin case holder ⑩ in the direction ⑤.
  - (Tightening torque : 1.5 to 2.5 N·m)
  - \* Check that the gauge ⑫ can go in clearance ④ and come out from it with light resistance.

### 3. Adjusting the needle stop position



#### WARNING :

To protect against possible personal injury due to abrupt start of the machine, be sure to start the following work after turning the power off and ascertaining that the motor is at rest.

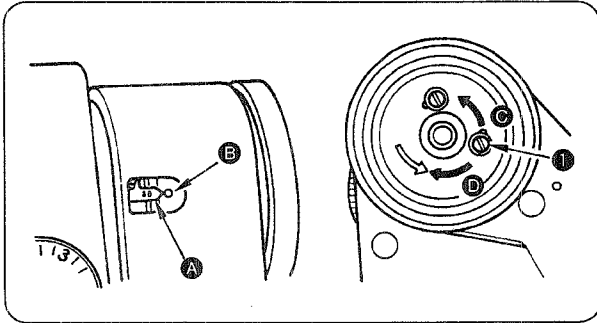

#### (1) Stop position after thread trimming

- 1) The standard needle stop position is obtained by aligning pointer A on the machine arm with white marker dot B on the handwheel.
- 2) Stop the needle in its highest position, and loosen screw 1 to perform adjustment within the slot of the screw.
  - ① The needle stop timing is advanced if you move the screw in direction C.
  - ② The needle stop timing is delayed if you move the screw in direction D.



Do not operate the machine with screw 1 loosened. Just loosen the screw, and do not remove it.

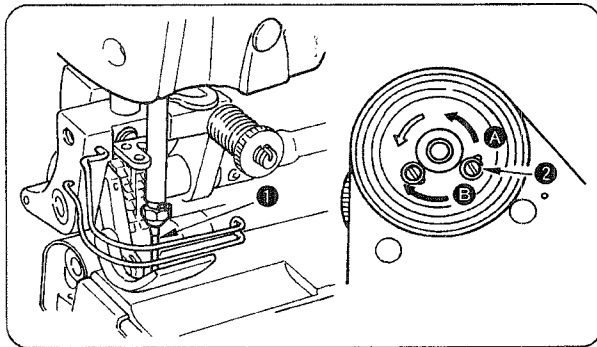

#### (2) Lower stop position

- 1) The lower needle stop position when the pedal is returned to the neutral position after the front part of the pedal is depressed can be adjusted as follows : Stop needle 1 in its lowest position, loosen screw 2, and make adjustment within the slot of the screw. Moving the screw in direction A advances the needle stop timing. Moving the screw in direction B delays the timing.



Do not operate the machine with screw 2 loosened. Just loosen the screw, and do not remove it.

### 4. Explanation and adjustment of the pedal components



#### WARNING :

To protect against possible personal injury due to abrupt start of the machine, be sure to start the following work after turning the power off and ascertaining that the motor is at rest.

#### Adjustment of the pedal

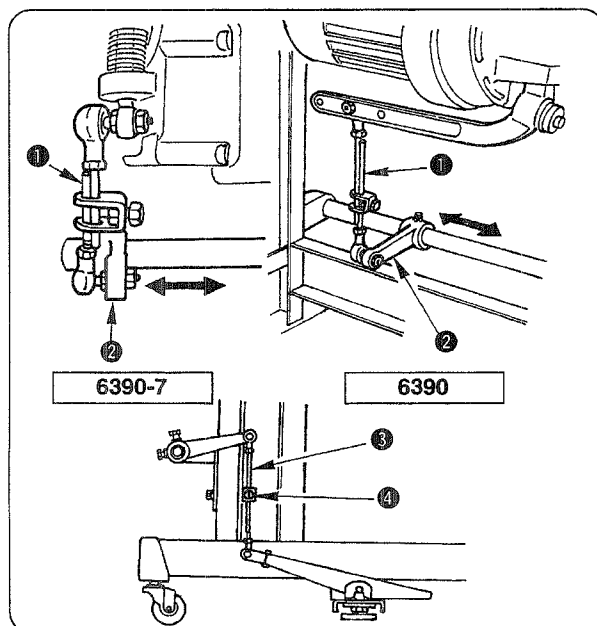

#### (1) Installing the connecting rod

- 1) Move pedal connecting arm 2 to the right or left as illustrated by the arrow so that connecting rod 1 is perpendicular.

#### (2) Adjusting the pedal angle

- 1) The pedal tilt can be freely adjusted by changing the length of the connecting rod 3.
- 2) Loosen adjust screw 4, and adjust the length of connecting rod 3.

## Adjustment of pedal toe down pressure, and heeling pressure

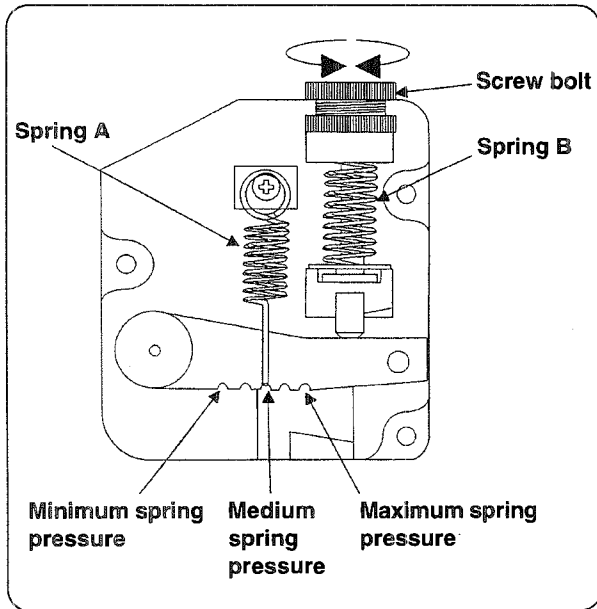

The pedal toe down force can be adjusted by changing the hooking position of spring A to the lever. (five level is available) Turn the screw bolt to adjust the spring B pressure.

## Pedal operation

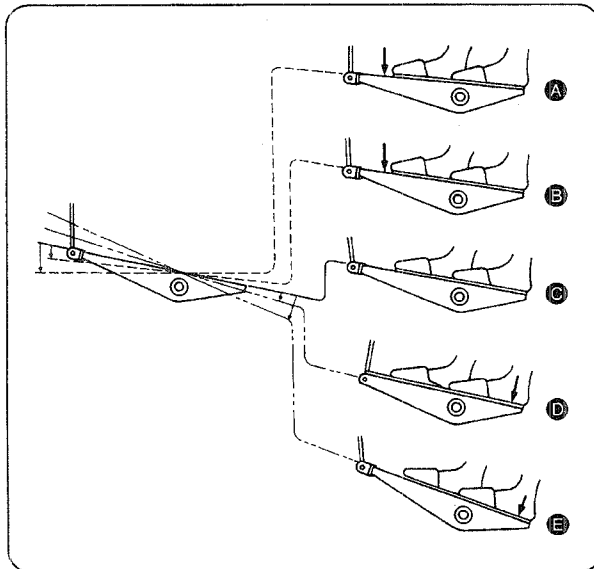

### (1) The pedal is operated in the following four steps :

- 1) The machine runs at low sewing speed when you lightly depress the front part of the pedal. **(B)**
- 2) The machine runs at high sewing speed when you further depress the front part of the pedal. **(A)**
- 3) The machine stops (with its needle up or down) when you reset the pedal to its original position. **(C)**
- 4) The machine trims threads when you fully depress the back part of the pedal. **(E)**
- 5) The presser foot goes up when you lightly depress the back part of the pedal **(D)**, and if you further depress the back part, the thread trimmer is actuated.

- The machine will perform normal thread trimming even if you depress the back part of the pedal immediately following high or low speed sewing.
- The machine will completely perform thread trimming even if you reset the pedal to its neutral position immediately after the machine started thread trimming action.

## 5. Adjusting the wiper

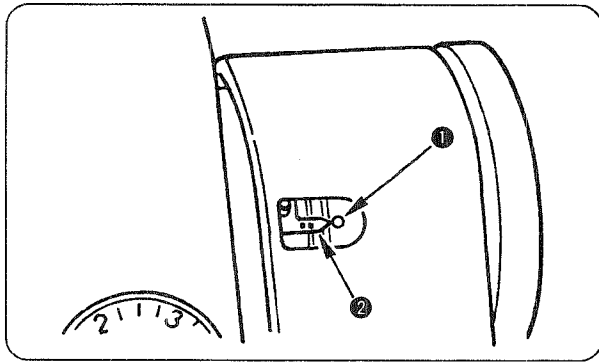

Adjust the wiper as follows when it is necessary to adjust it.

- 1) Turn the handwheel in the normal direction of rotation to align white marker dot ① engraved on the handwheel with pointer ② on the machine arm.

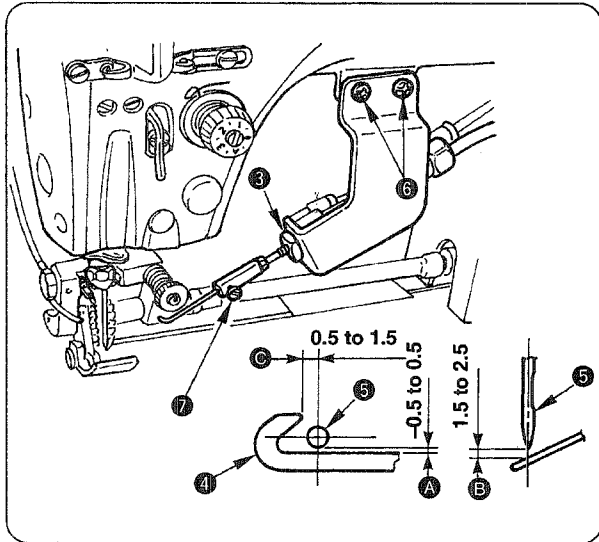

- 2) Loosen nut ③, move wiper ④ and adjust the distance between the wiper and needle ⑤ to  $-0.5$  to  $0.5$  mm for the adjustment of longitudinal direction ①.

\* After the adjustment, securely tighten nut ③.  
(Tightening torque : 3 to 5 N·m)  
(Note that the screw should face front.)

- 3) For adjusting vertical direction ②, loosen screws ⑥ and adjust the distance from top end of needle to 1.5 to 2.5 mm.

- 4) For adjusting protruding amount ③, loosen screw ⑦ and adjust the distance from needle to 0.5 to 1.5 mm.

\* After the adjustment, securely tighten screws ⑥.  
(Tightening torque : 3 to 4 N·m)

\* Check that the top end of the wiper does not come in contact with the presser and the finger guard when the wiper is in operation.

## 6. Hand lifter

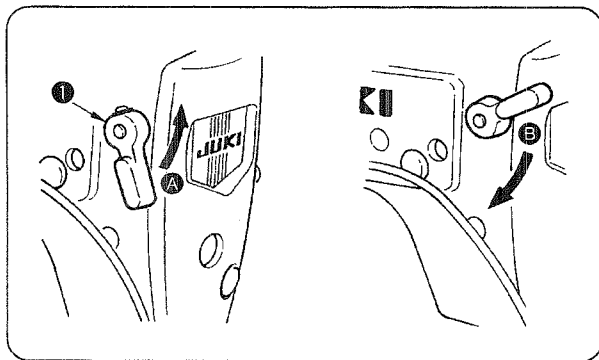

- 1) Turn presser lifting lever ① in the direction of ① to stop the presser foot at the position where it is lifted.

- 2) The presser foot goes up approximately 4.5 mm and stops.

It returns to the home position by lowering the presser lifting lever in the direction of ②.

## 7. Adjusting the presser foot pressure (upper feed roller) and the height of the presser foot (upper feed roller)



### WARNING :

To protect against possible personal injury due to abrupt start of the machine, be sure to start the following work after turning the power off and ascertaining that the motor is at rest.

### Adjusting the presser foot pressure

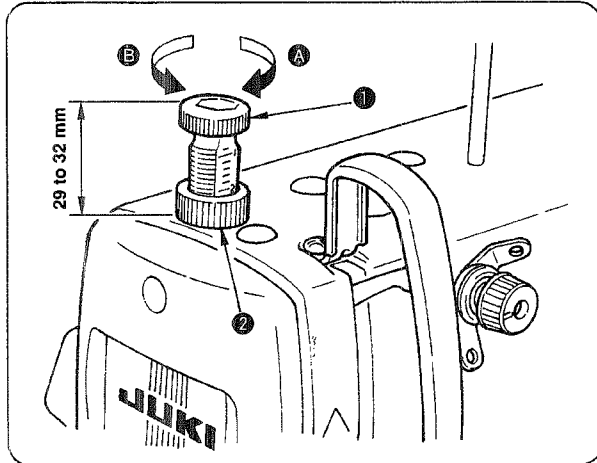

- 1) Loosen nut ②. As you turn presser spring regulator ① clockwise (in direction A), the presser foot pressure will be increased.
- 2) As you turn the presser spring regulator counter-clockwise (in direction B), the pressure will be decreased.
- 3) After adjustment, tighten nut ②.
- 4) The standard height of the presser spring regulator is 29 to 32 mm. (Top end of nut ② aligns with scale "2" of presser spring regulator ①.)

### Adjusting the height of the upper feed roller

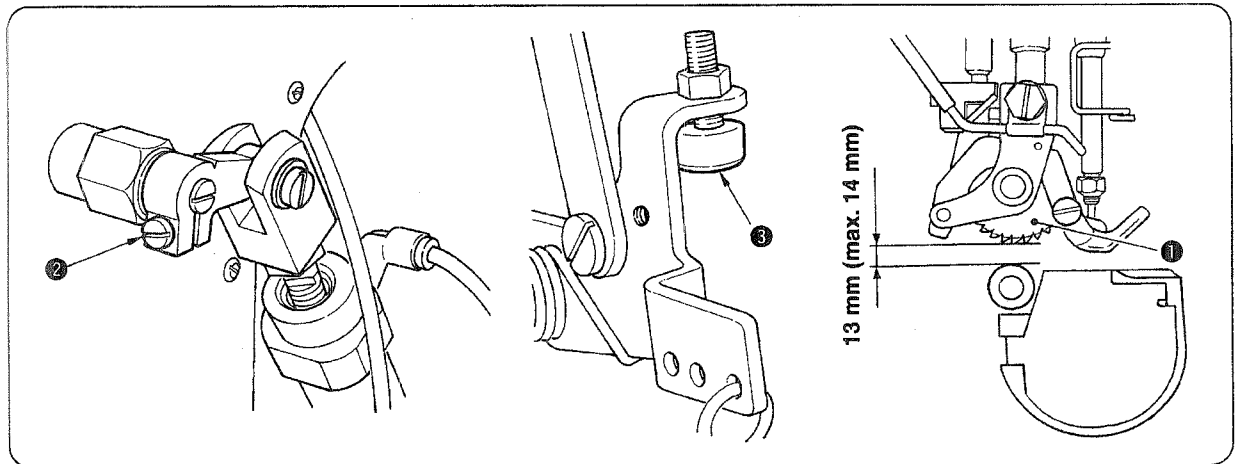

Adjustment of the height of upper feed roller ① can be performed by adjusting the position of screw ② (in case of 6390-7) or presser lifter stopper screw ③ (in case of 6390). (Adjusting value at the time of delivery : 13 mm)

\* Adjust the lifting amount of upper feed roller ① within the range of 14 mm or less.

## 8. Adjusting the presser foot pressure (presser foot (asm.)) and the height of the presser foot (presser foot (asm.))

### Adjusting the presser foot pressure

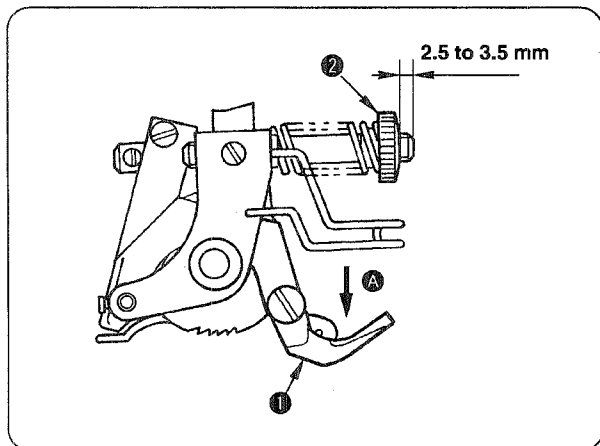

Turn dial ② to adjust the presser foot pressure of presser foot (asm.) ① in the direction of arrow mark ③ at the time of sewing. (Adjusting value at the time of delivery : shaft protruding amount : 2.5 to 3.5 mm)

- Tightening dial ② clockwise increases the presser foot pressure.
- Tightening dial ② counterclockwise decreases the presser foot pressure.

\* When the presser foot pressure is excessively high, the feed force will deteriorate. When the presser foot pressure is excessively low, sewing performance will be not stabilized.

Set the protruding amount of 3 mm as the standard and perform fine adjustment within the range where sewing performance or feed force is not affected.

### Adjusting the height of the presser foot

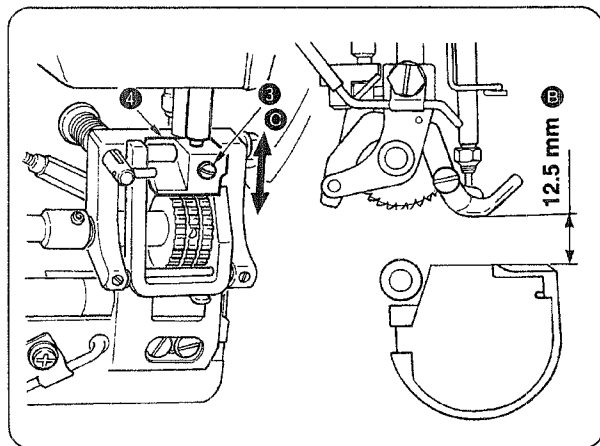

Adjust the height ⑤ of the presser foot (asm.) when the presser foot goes up by loosening setscrew ③ and changing position ④ of hand lifter base ④ in the vertical direction. (Adjusting value at the time of delivery : 12.5 mm)

- Lifting the fixing position of hand lifter base ④ increases height ⑤ of the presser foot.
- Lowering the fixing position of hand lifter base ④ decreases height ⑤ of the presser foot.

\* The top end of the needle protrudes from the bottom surface of the presser foot even when the presser foot is lifted when the sewing machine stops at UP position in the case where the height of the presser foot is more than 12.5 mm. As a result, cloth may be damaged by the top end of the needle.

When the height of the presser foot is 12.5 mm or less, cloth comes in contact with the presser foot when placing it on the sewing machine or removing it from the sewing machine at the time of sewing. As a result, operating efficiency will deteriorate.

\* Adjust the height of hand lifter base ④ so that the height of the presser foot should be within the range of 12 to 14 mm. After the completion of adjustment, securely tighten setscrew ③. (Tightening torque : 1.5 to 2.5 N·m)

## VII. TROUBLES IN SEWING AND CORRECTIVE MEASURES

Causes of troubles in sewing and corrective measures

Troubles	Causes (Items to be checked)	Corrective measures	Ref. page
Stitch skipping at overlapped section	Check whether clearance between needle and blade point of hook is proper.	Make the clearance between needle and blade point of hook come near to "0" when thread is caught.	23
	Check whether kind or size of needle is proper.	Replace the needle with a proper one. SCHMETZ UY180GVS is recommended. (Sewing performance is stabilized when using a thick one if possible.)	17
	Check whether blade point of hook has a scratch or is blunt.	Remove the scratch or replace the hook with a new one.	23
	Check whether relation of position between needle and needle hole is proper.	Adjust the position of throat plate and presser foot (asm.) to a proper one. (The proper position of needle in terms of needle hole in the throat plate is in the center of both sides and that in terms of needle hole in the presser foot (asm.) is slightly to the right side.)	-
	Check whether tension of thread take-up spring is too high.	Adjust the tension to a proper one. (0.2 N is recommended.)	21
	Check whether stroke of thread take-up is too small.	Adjust the position of thread take-up thread guide to a proper one. (The position of engraved marker line is the standard. Moving it to the left increases the stroke of thread take-up.)	21
	Check whether thread tension is too tight.	Decrease the thread tension.	21
	Check whether needle cooler air pressure is too high.	Set the air pressure to a proper one (it is better to set it to rather low).	38
	Check whether position of hemming binder is proper.	Adjust the position to a proper one. (Stitch skipping is apt to occur when needle pierces almost the edge of fold.)	5
	Check whether cloth is properly rolled.	Adjust by handling so that hemming of the bottom can be properly performed. (Feed force is not stabilized when cloth becomes thick due to the failure of rolling.)	-
	Check whether needle is bent or needle tip is blunt.	Replace the needle with a new one.	17
	Check whether needle attaching is proper. (Direction, insufficient insertion, etc.)	Properly attach the needle.	17
Check whether threading is not wrong.	Properly pass the thread.	18	
Thread breakage at overlapped section	Refer to item "Stitch skipping at overlapped section".	Refer to item "Stitch skipping at overlapped section".	-
Loading at overlapped section	Check whether cloth is properly rolled.	Adjust by handling so that hemming of the bottom can be properly performed. (Feed force is not stabilized when cloth becomes thick due to the failure of rolling.)	-
	Check whether installing position of needle cooler air pipe is proper.	Adjust the position to a proper one. (If the position is improper, the air pipe interferes with the presser foot (asm.) and may hinder the lift of the presser foot (asm.).)	38
	Check whether pressure of presser foot (asm.) is too high.	Properly adjust the presser foot (asm.) pressure. (If the presser spring regulator is excessively tightened, the lifting amount of the presser foot (asm.) decreases.)	28

Troubles	Causes (Items to be checked)	Corrective measures	Ref. page
Needle breakage	Check whether cloth is properly rolled.	Adjust by handling so that hemming of the bottom can be properly performed. (Feed force is not stabilized when cloth becomes thick due to the failure of rolling.)	-
	Check whether relation of position between needle and needle hole is proper.	Adjust the position of throat plate and presser foot (asm.) to a proper one. (The proper position of needle in terms of needle hole in the throat plate is in the center of both sides and that in terms of needle hole in the presser foot (asm.) is slightly to the right side.)	-
	Check whether the position of the hemming binder is proper.	Adjust the position to a proper one. (Needle is apt to break when needle pierces the limit of edge of the fold.)	5
Stitch skipping	Check whether clearance between needle and blade point of hook is proper.	Make the clearance between needle and blade point of hook come near to "0" when thread is caught.	23
	Check whether blade point of hook has a scratch or is blunt.	Remove the scratch or replace the hook with a new one.	23
	Check whether thread tension is too high.	Decrease the thread tension.	21
	Check whether the position of the hemming binder is proper. (Check whether the hemming binder interferes with the presser foot (asm.).)	Adjust the position to a proper one. (When the hemming binder interferes with the presser foot (asm.), the presser foot (asm.) rises from the throat plate, or the motion is limited.)	5
Thread breakage	Check whether clearance between needle and blade point of hook is proper.	Make the clearance between needle and blade point of hook come near to "0" when thread is caught.	23
	Check whether blade point of hook has a scratch or is blunt.	Remove the scratch or replace the hook with a new one.	23
	Check whether thread tension is too high.	Decrease the thread tension.	21
	Check whether the position of the hemming binder is proper. (Check whether the hemming binder interferes with the presser foot (asm.).)	Adjust the position to a proper one. (When the hemming binder interferes with the presser foot (asm.), the presser foot (asm.) rises from the throat plate, or the motion is limited.)	5
	Check whether needle attaching is proper. (Direction, insufficient insertion, etc.)	Properly attach the needle.	17
	Check whether the tension of thread tension No. 1 is low. (In case of thread trimmer)	Adjust the tension to such an extent that unsteadiness of thread does not occur.	21
	Check whether quality of thread is not good.	Use a good quality thread.	-
	Check whether thread is cut from heat.	Increase the amount of oil in the hook.	16
Looping	Check whether kind or size of needle is proper.	Replace the needle with a proper one. SCHMETZ UY180GVS is recommended. (Sewing performance is stabilized when using a thick one if possible.)	17
	Check whether relation of position between needle and needle hole is proper.	Adjust the position of throat plate and presser foot (asm.) to a proper one. (The proper position of needle in terms of needle hole in the throat plate is in the center of both sides and that in terms of needle hole in the presser foot (asm.) is slightly to the right side.)	-
	Check whether needle cooler air pressure is too high.	Set the air pressure to a proper one (it is better to set it to rather low).	38
	Check whether thread tension is too low.	Increase the thread tension.	21
	Check whether the tension of thread take-up spring is low or the stroke is small.	Adjust the tension or the stroke to a proper value. (0.2N and 8 mm are recommended.)	21
	Check whether the tension of thread is proper.	Re-adjust the tension of thread to a proper one. (If the thread tension is too low, needle thread is not fully drawn up, and if it is too high, the twist is tightened and looping is apt to occur.)	21

Troubles	Causes (Items to be checked)	Corrective measures	Ref. page
Looping	Check whether something is wrong with hook. (Play of inner hook is large or rotation is not smooth.)	Replace the hook with a new one.	23
Irregular thread tension	Check whether thread tension is too low.	Increase the thread tension.	21
	Check whether threading is wrong.	Properly pass the thread.	18
	Check whether the spring for idle-prevention is weak.	Raise the spring or replace it with a new one.	17
Puncture of cloth from hemming binder	Check whether cloth is properly rolled.	Adjust by handling so that hemming of the bottom can be properly performed.	-
Uneven material feeding at start and end of sewing	Check whether cloth is properly rolled.	Adjust by handling so that hemming of the bottom can be properly performed. (It is important that the cloth is properly rolled by the hemming binder at the start of sewing.)	-
	Check whether position of hemming binder is proper.	Adjust the position to a proper one. (Rolling is stabilized when the ruler located on the right side of hemming binder is set to the position where the bottom surface hardly comes in contact with the throat plate and the side hardly comes in contact with the presser foot (asm.).)	5

## IX. THREAD TRIMMER COMPONENTS

### 1. Checking the receding position of the moving knife and the correcting method

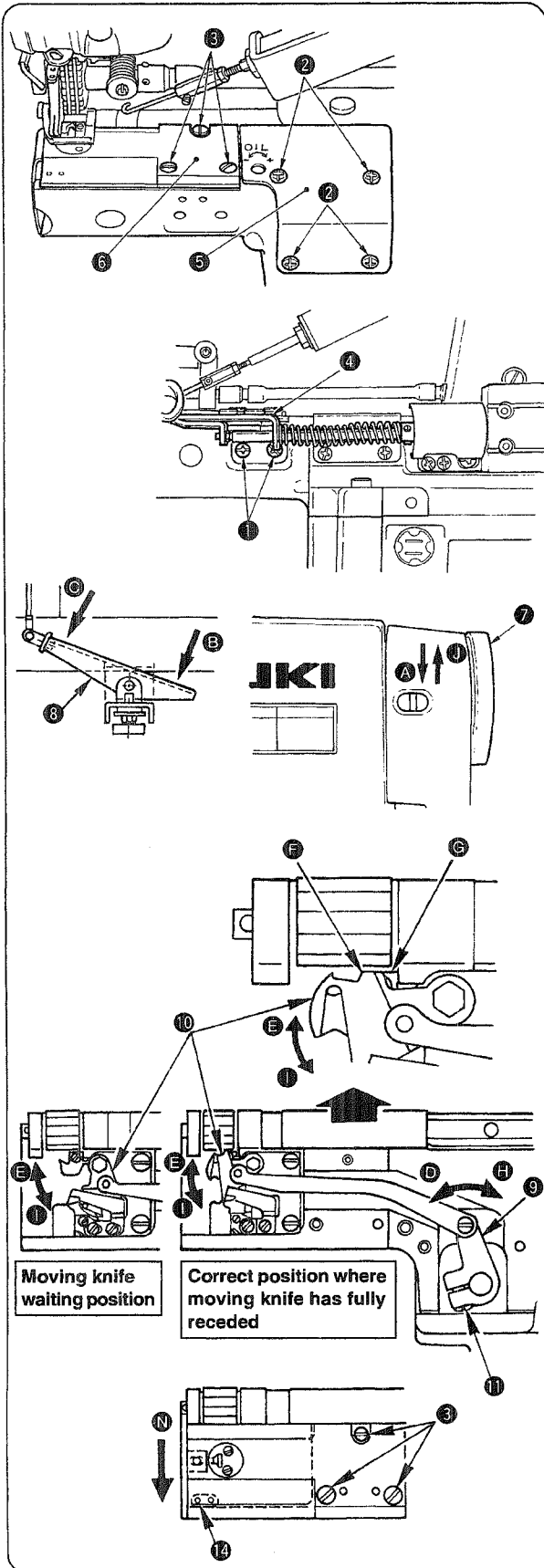

- 1) Make sure that the power to the sewing machine is turned OFF.
- 2) Remove setscrews ①, setscrews ② and setscrews ③. Then remove hemming binder ④, auxiliary throat plate ⑤ and throat plate ⑥.
- 3) Replace the connectors.
  - Disconnect connector ② from SC-510.
  - Disconnect connector ⑦ and connect connector ⑦ to the detector of SC-510 to which connector ② is connected.
  - Remove connector ⑧ to connect the motor of SC-510 and the control box.
 (Refer to "Wiring diagram of pneumatic and electric components" on the next page.)
- 4) Turn ON the power to the sewing machine.
- 5) Turn the handwheel ⑦ by hand in the normal direction of rotation of the sewing machine ①. (Normal direction of rotation of the sewing machine ① is the counterclockwise direction as observed from the handwheel side.)
- 6) When the needle bar goes up and the top end of needle comes higher than the moving knife, depress the back part of pedal ⑧ in the direction ②.



**At this time, never depress the front part of pedal ⑧ in the direction ③.**

(By depressing the front part of the pedal, the thread trimmer magnet is turned ON and the roller enters the thread trimmer cam in the sewing machine.)

- 7) Then turn the handwheel ⑦ by hand in the normal direction of rotation of the sewing machine.
- 8) Moving knife lever ⑨ turns counterclockwise in the direction ④ and moving knife ⑩ starts receding in the direction ⑤.
- 9) When moving knife ⑩ has fully receded, the position where convex ⑥ of moving knife ⑩ aligns with end ⑦ of the thread pulling plate is the correct position of moving knife receding position.



**The power switch has been turned ON during the operation of steps 4) through 9). Never depress the front part of pedal ⑧ in the direction ③.**

- 10) At this time, if the receding amount is not proper, be sure to turn OFF the power switch of the sewing machine, loosen moving knife tightening screw ⑪, and tighten moving knife tightening screw ⑪ (tightening torque : 3 to 4 N·m) so that convex ⑥ of moving knife ⑩ aligns with end ⑦ of the thread pulling plate to adjust the moving knife to the correct receding position.
- \* Checking the fully receded position of the moving knife and the correcting operation have been completed in steps 1) through 10). Be sure to return the connectors replaced in step 3) and return the components removed in steps 1) and 2) as well. Then securely tighten the setscrews.
- \* When installing the throat plate, push it in the direction of arrow mark ⑮ and tighten setscrews ⑬ in the state that stopper ⑭ comes in contact with the frame.

## 2. Checking the thread trimmer cam timing

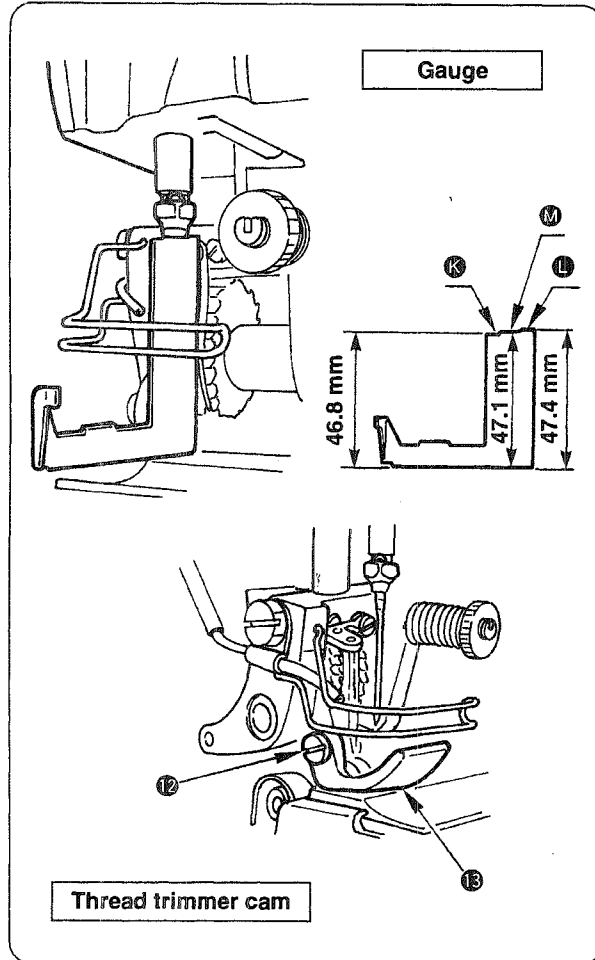

Operation of steps 1) through 8) is the same as that of "Checking the receding position of the moving knife". Perform the steps 1) through 8).

9) Then turn the handwheel ⑦ in the normal direction of rotation of the sewing machine ④ while depressing the back part of pedal ⑧ in the direction ③.

(Moving knife lever ⑨ turns clockwise in the direction ⑥ and moving knife ⑩ starts moving in the direction ① after the moving knife has fully receded, and the moving knife returns to the waiting position.)

10) Turn handwheel ⑦ in the reverse direction ⑤ of rotation of the sewing machine after the moving knife has returned to the waiting position, and the handwheel stops turning at a certain angle.



**Be sure to turn OFF the power switch of the sewing machine after the operation in steps 4) through 10) has been completed.**

11) At this time, the thread trimmer cam timing is normal if the height of the needle bar from the top surface of the throat plate is 46.8 to 47.4 mm.

\* The timing can be checked with ease when using the gauge supplied with the machine as accessories.

When section ① of the gauge enters between the throat plate and the bottom end of the needle bar and section ② does not enter, the height of the needle bar is within the range of 46.8 to 47.4 mm. Then the thread trimmer cam timing is normal.

\* When entering the gauge under the bottom end of the needle bar, loosen setscrew ⑫ and remove presser foot ⑬. After the completion of the operation, return presser foot ⑬ to the home position and securely tighten setscrew ⑫. (Tightening torque : 1.5 to 2 N·m)

12) When the height of the needle bar from the top surface of the throat plate is not 46.8 to 47.4 mm, the thread trimmer cam timing is not proper. Correct the thread trimmer cam timing in accordance with the Engineering Manual.



## X. SETUP OF OPTIONAL COMPONENTS

### 1. Needle cooler

- Needle cooler can reduce the occurrence of thread breakage due to the heat of needle when the sewing machine runs at a speed of 4,000 rpm or more.
- Needle cooler uses air. Refer to the table below and select the part used since the components vary according to the machine head (with thread trimmer or without thread trimmer).

Machine head	Part used
DLN-6390-7 (with thread trimmer)	40004070 Needle cooler (DLN-6390-7)
DLN-6390 (without thread trimmer)	40004071 Needle cooler (DLN-6390)

#### (1) Installing the top action air switch unit (without thread trimmer)



#### WARNING :

To protect against possible personal injury due to abrupt start of the machine, be sure to start the following work after turning the power off and ascertaining that the motor is at rest.

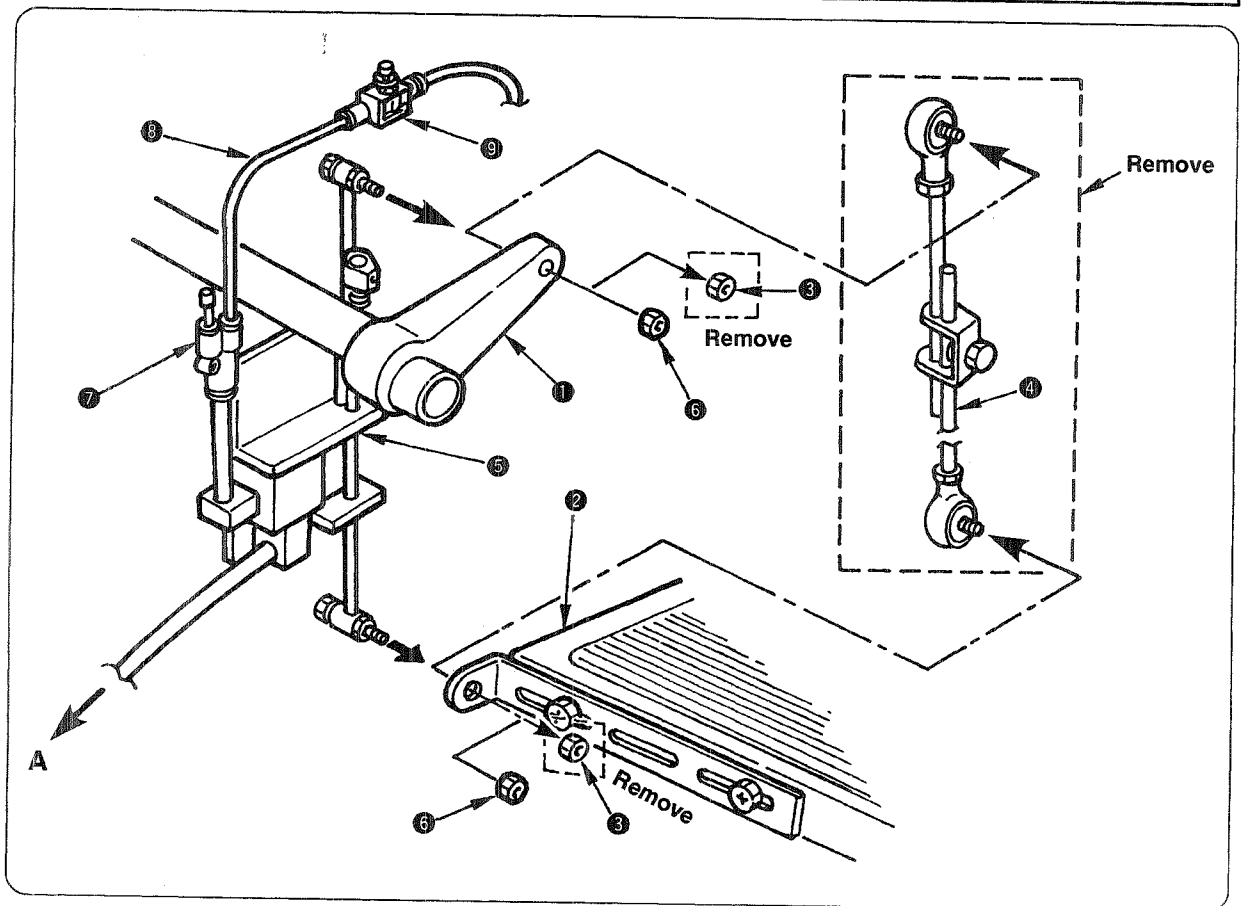

- 1) Remove nut ① connecting pedal connecting arm ① and pedal ② of the table and stand, and remove connecting rod (asm.) ④.
- 2) Install top action air switch unit ⑤ and fix it with nut ⑥ supplied with the unit.
- 3) Connect air hose ⑧ to air joint ⑦ and install speed controller ⑨ at the top end of the air hose.

## (2) Installing the air unit



### WARNING :

To protect against possible personal injury due to abrupt start of the machine, be sure to start the following work after turning the power off and ascertaining that the motor is at rest.

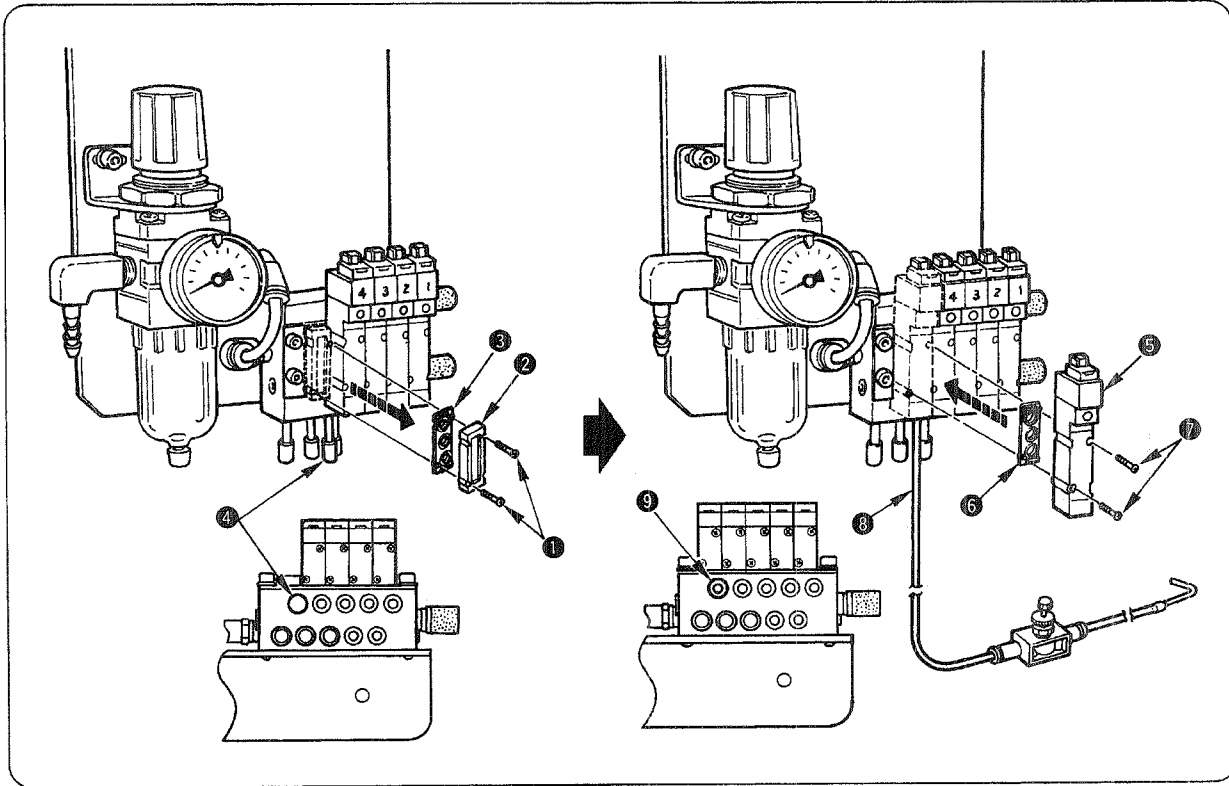

### [In case of the machine with thread trimmer]

- 1) Remove screw ① and remove plate ② and gasket ③.
- 2) Draw out plug ④.
- 3) Install solenoid valve ⑤ and gasket ⑥ in the needle cooler for the machine with thread trimmer using screws ⑦.



- When tightening screws ⑦ :
  - Air leaks when tightening the screws excessively loose.
  - Screw thread breaks when tightening the screws excessively tight.  
Be careful when tightening the screws since the aforementioned matters may occur.  
The standard of tightening torque is 0.17 N·m.
- When installing solenoid valve ⑤, be careful that gasket ⑥ does not slip out of position.

- 4) Connect air tube ⑧ in the needle cooler to hole ⑨.

\* For the installing position, refer to the drawing of the table for reference.

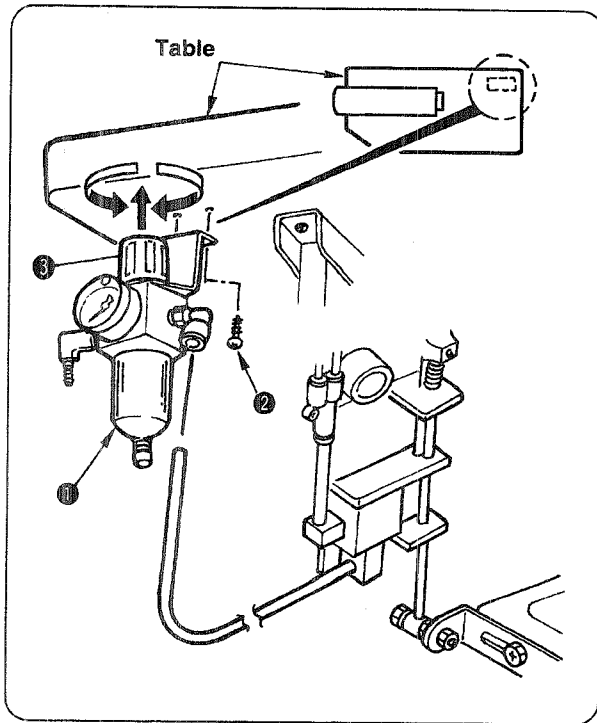

**[In case of the machine without thread trimmer]**

- 1) Install air (asm.) ① on the bottom face of the table with two screws ② supplied with the unit at the position as shown in the figure.
- 2) Pull upward knob ③ located at the upper part of the air (asm.) and turn it to the right or left to adjust the pressure to approximate 0.5 MPa.

**Caution** After adjusting the pressure, fully push down the knob ③ until it comes down to its home position.

ENGINE

(3) Installing the needle cooler pipe (asm.)



**WARNING :**

To protect against possible personal injury due to abrupt start of the machine, be sure to start the following work after turning the power off and ascertaining that the motor is at rest.

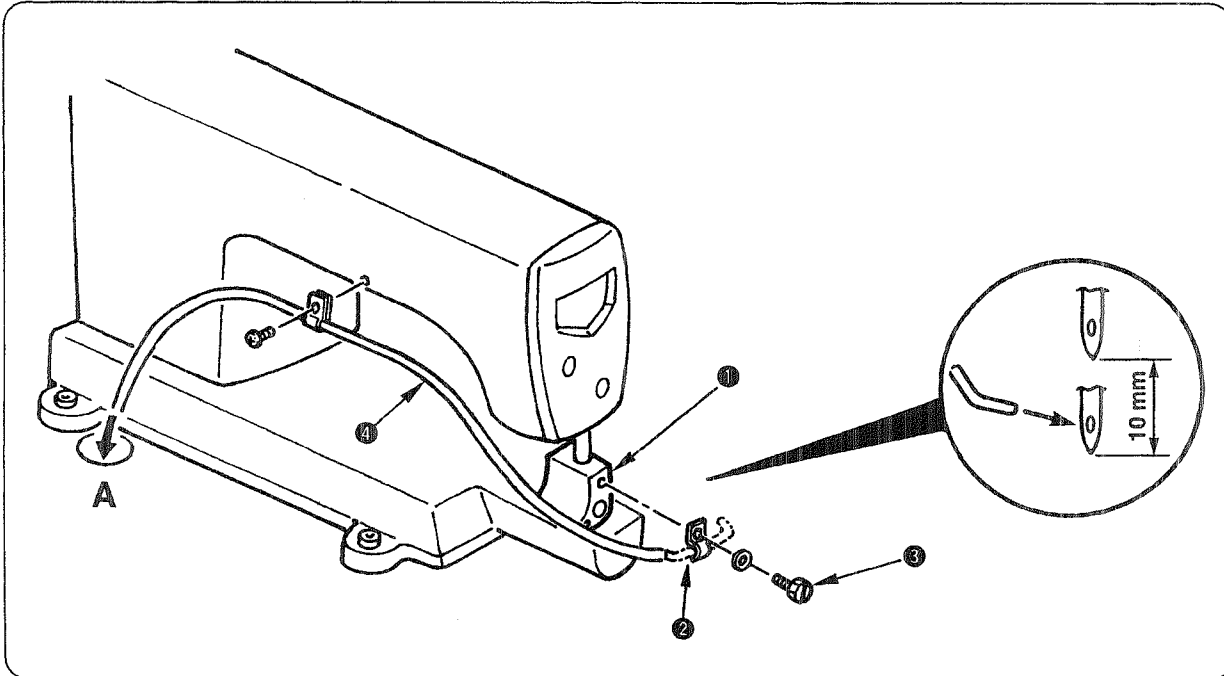

- 1) Install needle cooler pipe (asm.) ② on presser base ① with screw ③.
- 2) Adjust so that the top end of the needle cooler pipe faces to the needle hole which is located 10 mm below from the upper dead position of the needle bar.
- 3) Pass air hose ④ of the needle cooler pipe through the hole A in the table and connect it to the speed controller.



After installing the needle cooler pipe, make sure of the following matters.

1. Turn the handwheel by hand and check that the needle does not interfere with the pipe.
2. Check that the presser foot does not interfere with the pipe when the presser foot gets over the overlapped section.

(4) Adjusting the speed controller

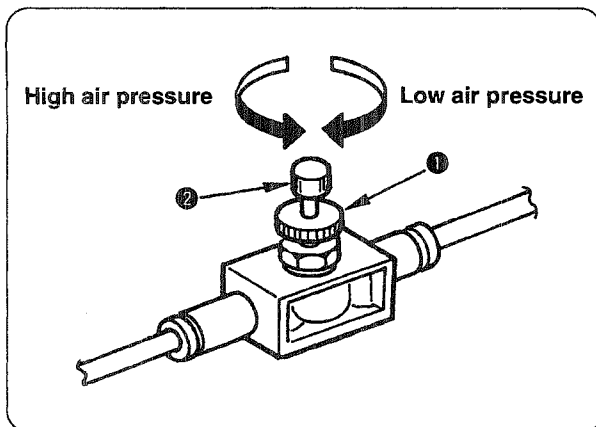

- 1) Loosen lock nut ① and turn knob ② to adjust the air pressure for needle cooler.  
Adjust the air pressure to such an extent that sewing is not affected.



After the adjustment, be sure to tighten lock nut ①.



The knob has been turned back by 4.5 times from full closing at the time of delivery.

When the air pressure is too low, there is no effect of needle cooling. When the air pressure is too high, thread slips off the needle at the start of sewing or sewing performance is not stabilized.

## XI. SETTING OF SC-510

### 1. Setting of the auto lifter function

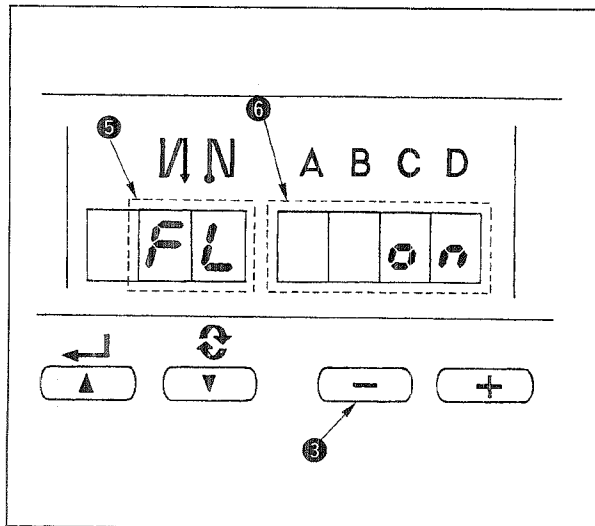

When the auto-lifter device (AK) is attached, this function makes the function of auto-lifter work.

- 1) Turn ON the power switch while pressing switch ③ inside the control box.
- 2) LED display is turned to ⑤, ⑥ (FL ON) with “beep”, and the function of auto-lifter becomes effective.
- 3) Turn OFF the power switch, and turn ON the power switch again to return to the normal mode.
- 4) Repeat the operation 1) to 3), and LED display is turned to (FL OFF). Then, the function of auto-lifter does not work.

FL ON : Auto-lifter device becomes effective.

FL OFF : Auto-lifter function does not work.

(Standard at the time of delivery)

(Similarly, the presser foot is not automatically lifted when programmed stitching is completed.)

- (Caution)
1. To perform re-turning ON of the power, be sure to perform after the time of one second or more has passed.  
(If ON / OFF operation of the power is performed quickly, setting may be not changed over well.)
  2. Auto-lifter is not actuated unless this function is properly selected.
  3. When “FL ON” is selected without installing the auto-lifter device, starting is momentarily delayed at the start of sewing. In addition, be sure to select “FL OFF” when the auto-lifter is not installed since the touch-back switch may not work.

A large rectangular area with rounded corners, containing a series of horizontal lines for writing. The lines are evenly spaced and extend across the width of the page. The top portion of the page is blank, while the bottom portion is filled with these lines.

A large rectangular writing area with rounded corners, containing 20 horizontal lines for text. The lines are evenly spaced and extend across most of the width of the page.

A large rectangular box with rounded corners, containing a series of horizontal lines for writing. The box is empty and occupies most of the page.