



# DDL-560-5 MODEL DDL-560-4

1-NEEDLE LOCKSTITCH SEWING MACHINE  
WITH DOUBLE-SIZED HOOK AND AUTOMATIC  
THREAD TRIMMER

## INSTRUCTION BOOK

Before operating your JUKI Lockstitch Machine, please read this Instruction Book carefully in order to operate it in a correct and efficient manner.

*and Spunth  
Atlanta  
Jody*

### CAUTIONS BEFORE OPERATION

1. Don't run the machine before filling the oil reservoir with the prescribed lubricating oil.
2. After setting up your machine, make sure that it runs in the correct direction; lower the needle by turning the handwheel manually, and watch the handwheel's revolution by momentarily switching the power "on" (correct rotational direction of the handwheel: counter-clockwise when viewed from the handwheel's end).
3. Ascertain that the correct voltage and phases (three phases, single phase) are indicated on the name plate of the motor used.
4. Run the sewing machine at 225 s.p.m. to 245 s.p.m. when operating the automatic thread trimmer. (Refer to "26. ADJUSTING THE THREAD TRIMMING SPEED".)

### CAUTIONS IN OPERATION

1. Don't put your hand under the needle when you turn "on" the power switch or operate the machine.
2. Don't put your hand into the thread take-up cover while the machine is running.
3. Don't forget to cut off the power supply before you tilt the machine head backwards or replace the V-belt.
4. Never bring your fingers or hair close to, or place anything on the handwheel, V-belt, bobbin winder wheel or motor during operation. It may lead to serious personal injuries.
5. If your machine is provided with a belt cover, finger guard and eye guard, never operate your machine with any of them removed.

## 1. INSTALLATION

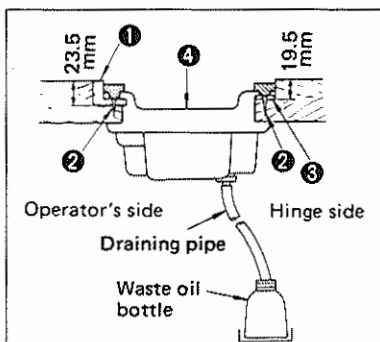

### ★ Attaching the oil reservoir

Install the oil reservoir in the way that it is supported by four corners of the opening in the table. Nail two rubber cushions ① to a protruded edge from the table opening at operator's side using nails ② and also attach two head-rest cushions ③ to a protruded edge at the far end (hinge side) using nails ②, and the place oil reservoir ④ on the cushions. Install the waste oil bottle and the draining pipe as illustrated.

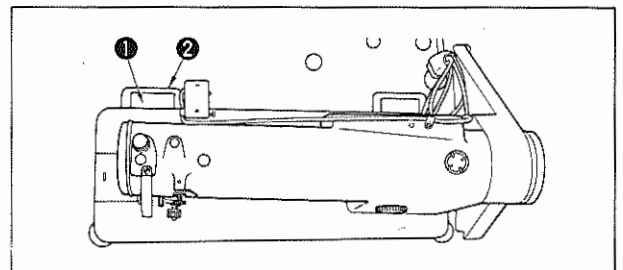

Insert hinge ① into the hole in the bed and engage it with rubber hinge ② on the table, lowering the head onto the four corner rubber cushions.

## 2. LUBRICATION

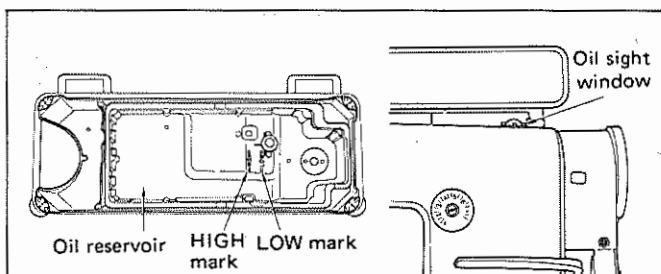

### ★ Before operation

1. Fill the oil reservoir with Juki New Defrix Oil No. 1 up to the HIGH mark.
2. Whenever the oil level drops to the LOW mark, add more oil.
3. When the sewing machine is run after the oil reservoir has been filled, oil can be seen splashing on the oil sight window.

However, the amount of oil splash has no relation to the amount of oil in the reservoir so there is no need to worry.

(Note) When using a new sewing machine or one that has not been used for a long time let it idle for about ten minutes at 2,500 ~ 3,000 s.p.m. to run it in.

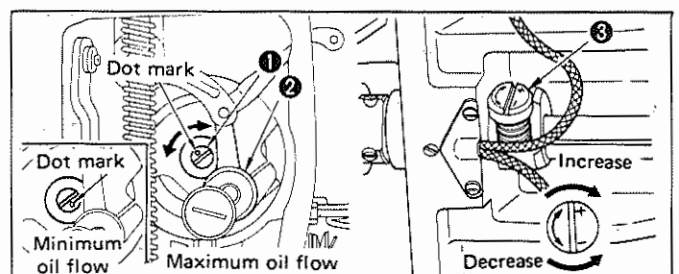

### ★ Adjustment of oil amount for the face plate components:

Amount of lubricating oil supplied to the face plate components such as thread take-up lever and needle bar crank is adjustable by turning adjusting pin ①: bring the dot mark engraved on the adjusting pin close to needle bar crank ② to minimize or farthest from the needle bar crank to maximize the amount of oil.

### ★ Lubrication of hook unit

When the oil feed adjusting screw ③ on the hook driving shaft is turned in the (+) direction the flow of oil increases, while when turned in the (-) direction it decreases.

### 3. INSTALLING THE THREAD STAND

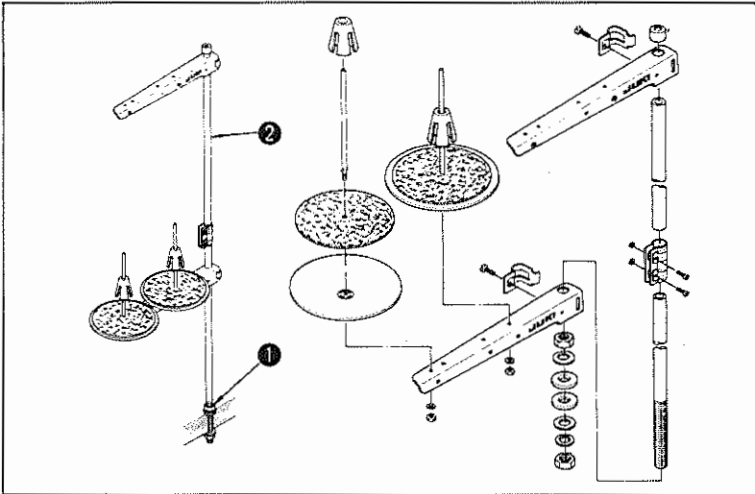

Assemble the thread stand and install it into the hole provided in the table.

Tighten the nut ① until it will no longer turn. Furthermore, if the wiring is to be installed in the ceiling, pass the power cord through the spool rod ②.

### 4. INSTALLING THE BELT COVER AND THREAD WINDER

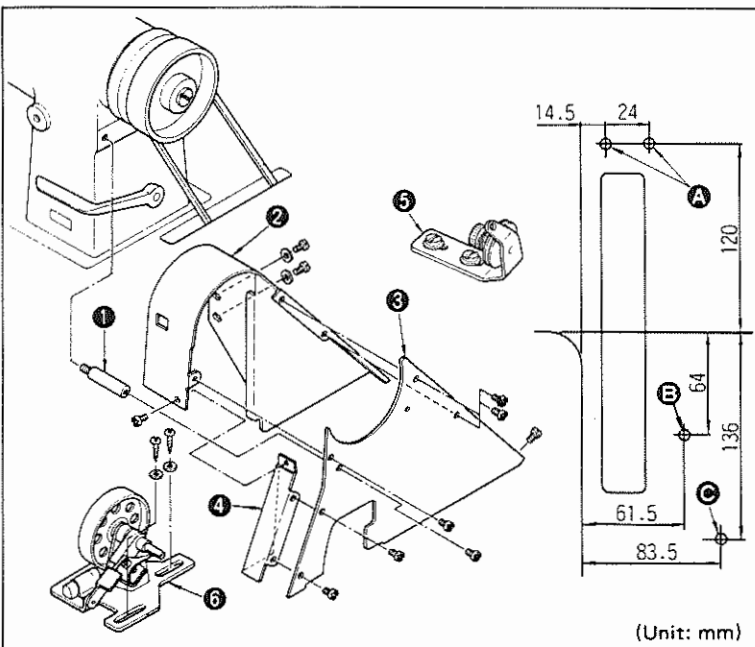

(Installing procedure)

1. Make four wood screw guide holes ( A , B and C ) in the machine table.
2. Screw belt cover support ① into the tapped hole in the arm.
3. Attach belt cover ② to the machine head, using the setscrew.
4. Slightly tilt the machine head backward, put belt cover top ③ inside the outer ring of the pulley, then fix belt cover top ③ with four screws.
5. Fix belt cover top ③ to support ①.
6. Loosen the setscrew of the belt cover. Properly position belt cover ②, then screw the belt cover.
7. Fix thread winder cover ④ with three screws. Using wood screws, fix thread winder tension controller ⑤ at A, and fix thread winder ⑥ at B and C.

## 5. ATTACHING THE NEEDLE

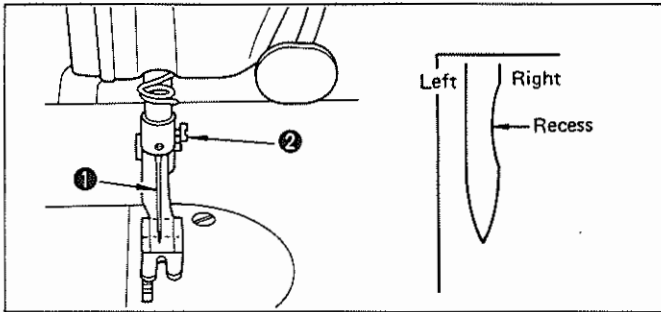

### ★ Turn the motor off

Use DB x 1 and DP x 5 needles.

Although there are many needle gauges, use the appropriate one according to the thickness of the thread used and the type of fabric.

1. Turn the handwheel and raise the needle bar to its highest position.
2. Loosen needle clamp screws ② and hold needle ① so that the recess is facing exactly to the right.
3. Push the needle deep into the needle clamp hole until it will go no further.
4. Tighten the needle clamp screws ② firmly.

## 8. INSERTING THE BOBBIN

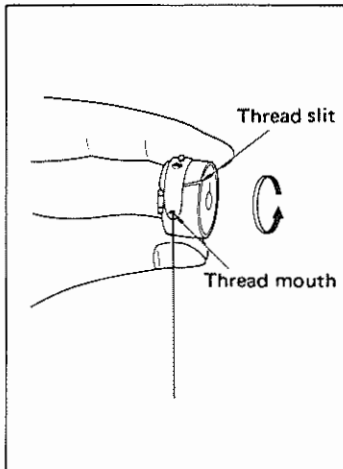

1. Hold the bobbin in your hand and insert it into the bobbin case (spring-loaded) so that the thread will be wound counterclockwise.
2. Pass the thread through the thread slit in the bobbin case and pull it, then the thread can be drawn out through the thread mouth after passing under the tension spring.

★ Arrange it so that the bobbin will rotate in the direction of the arrow when pulling the looper thread.

## 9. THREADING THE MACHINE

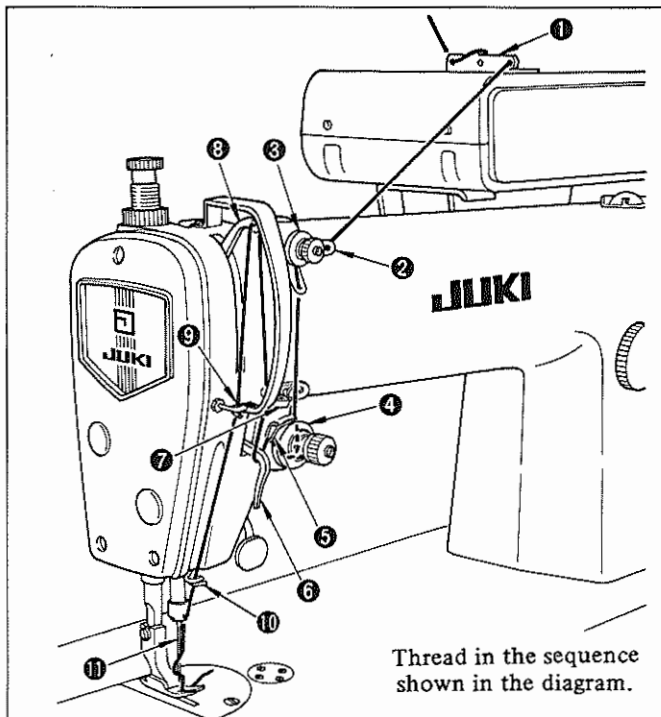

Thread in the sequence shown in the diagram.

## 6. SETTING THE BOBBIN CASE

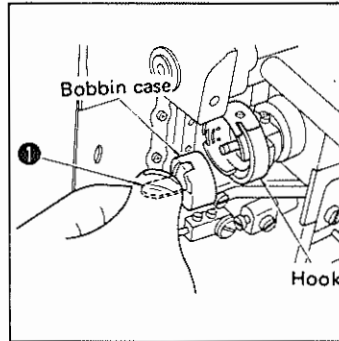

1. Raise the latch ① on the bobbin case and extract the case. If the latch is held up, the bobbin will not drop.
2. When inserting the bobbin case, insert it fully into the shaft of the hook and lower the latch to close it.

## 7. WINDING THE BOBBIN THREAD

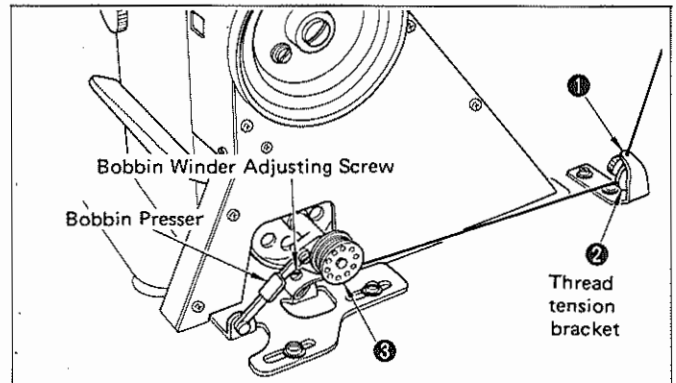

1. Thread in the sequence shown in the diagram and wind the thread around the bobbin several times.
2. Tilt the positioning finger and make the bobbin winder pulley touch the belt.
3. Set the bobbin winder adjusting screw so that 80% of the full amount can be wound. Turning bobbin winder adjusting screw clockwise increases the winding amount, while turning it counterclockwise decreases it.
4. If the thread tends to be wound on one side, shift the thread tension bracket laterally to ensure even winding.
5. When the winding ends the bobbin presser slips off and the bobbin winder stops automatically.

## 10. ADJUSTING THE STITCH LENGTH

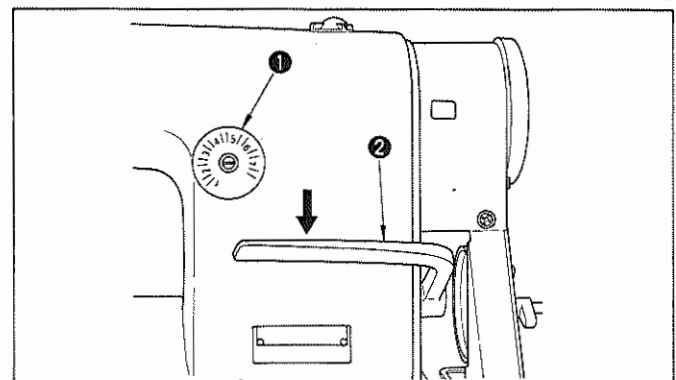

Turn feed regulator dial ① counterclockwise or clockwise and align the desired number with the pin protruding from the arm.

The numbers on the dial indicate millimeters.

When reducing the indication turn the feed regulator dial while depressing reverse feed control lever ②.

### ★ Reverse stitching

1. Depress reverse feed control lever ②.
2. Reverse stitching is possible while the lever is depressed.
3. When the lever is released, the sewing direction will return to normal.

## 11. PEDAL OPERATIONS

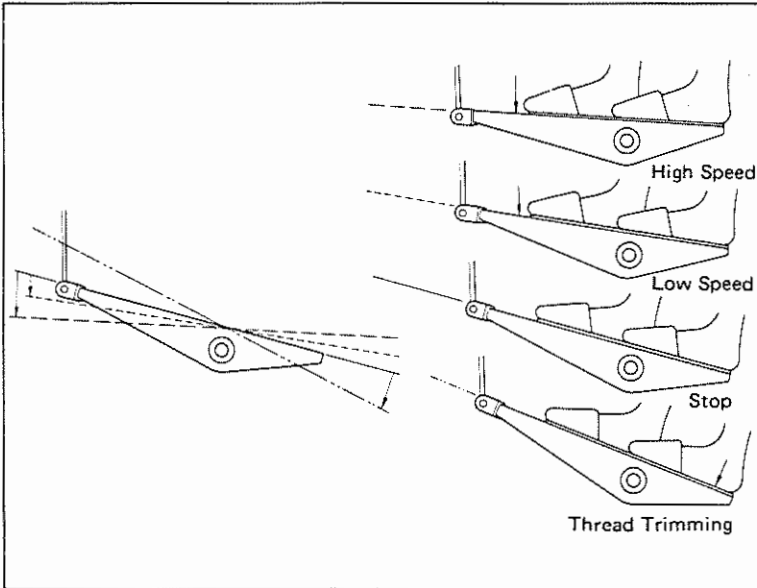

The pedal is operated in four stages.

1. When the front part of the pedal is depressed lightly, low-speed stitching is performed.
  2. When it is depressed further, high-speed stitching is realized. (However, if an automatic reverse stitching switch is installed, high-speed stitching will only begin after the reverse stitching ends.)
  3. When the treading pressure is released and the foot rests lightly on the pedal again, the sewing machine will stop. (At this point the needle will be down)
  4. When the rear part of the pedal is pushed down strongly with the heel, the thread-trimmer will operate.
- Even when the rear part of the pedal is depressed in one stroke during high speed or low speed stitching, the thread trimmer will operate normally.
  - Immediately after the machine starts thread trimming, even if the pedal is returned to the neutral position, thread trimming will be completed.
  - When the machine stops, the needle will stop in the down position. If you wish to raise the lowered needle, firmly depress the rear part of the pedal once.

## 12. THREAD TENSION

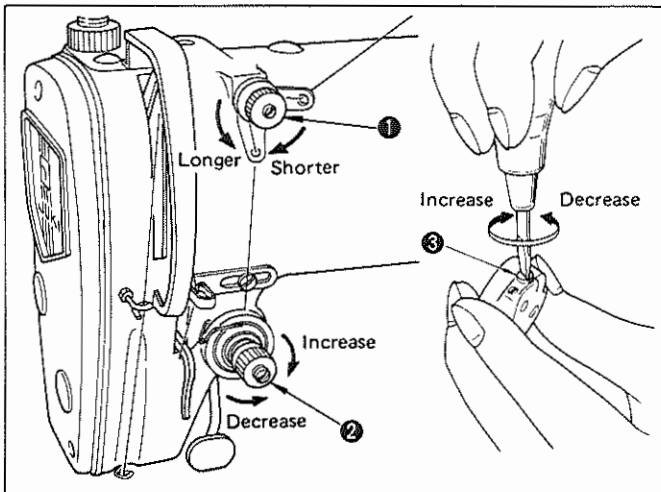

### ★ Adjusting the needle thread tension

When tension nut No. 1 ① is turned clockwise the length of the thread remaining at the needle tip becomes shorter. When it is turned counterclockwise it becomes longer. When tension nut No. 2 ② is turned clockwise the tension of the needle thread increases.

When it is turned counterclockwise the tension decreases.

### ★ Adjusting the bobbin thread tension

When thread tension screw ③ is turned clockwise the bobbin thread tension increases. When it is turned counterclockwise the tension decreases.

## 14. PRESSER LIFTER

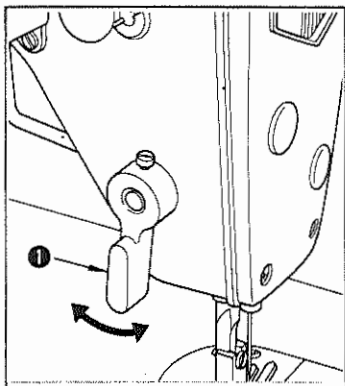

In order to stop the presser foot in the raised position, turn presser lifter ① clockwise. The presser foot will stop after rising about 6 mm. It can be lowered to its original position by lowering the presser lifter. When using the presser lifter, the presser foot will rise about 13 mm.

## 13. THREAD TAKE-UP SPRING

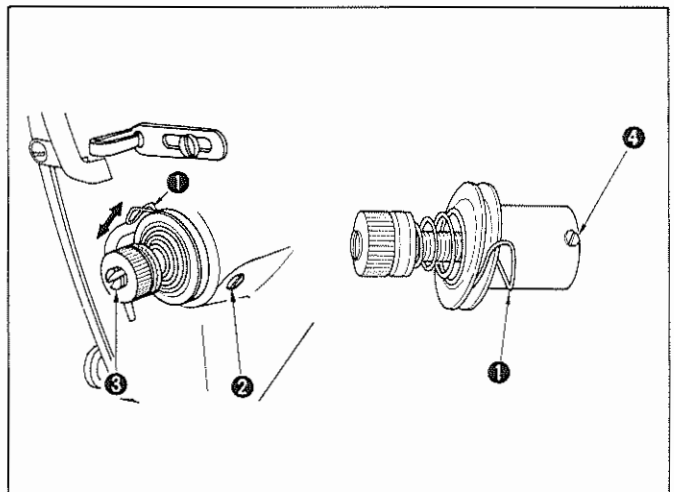

### ★ Adjusting the stroke of thread take-up spring ①

Loosen setscrew ② on the tension post socket and turn tension post ③.

### ★ Adjusting the tension of thread take-up spring ①.

1. Loosen setscrew ② and remove tension post ③.
2. Loosen setscrew ④ and adjust as follows.
3. When tension post ⑤ is turned clockwise the spring tension increases. When it is turned counterclockwise the spring tension decreases.

## 15. PRESSING FORCE OF THE PRESSER FOOT

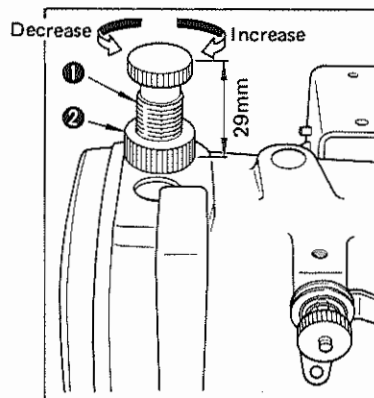

When nut ② is loosened and presser spring regulator ① is turned clockwise the pressure increases. When it is turned counterclockwise the pressure decreases. Tighten nut ② after adjustment.

In the case of general fabrics the standard height of the presser spring regulator is 29 mm (5 kg).

## 16. ADJUSTING THE FEED TIMING

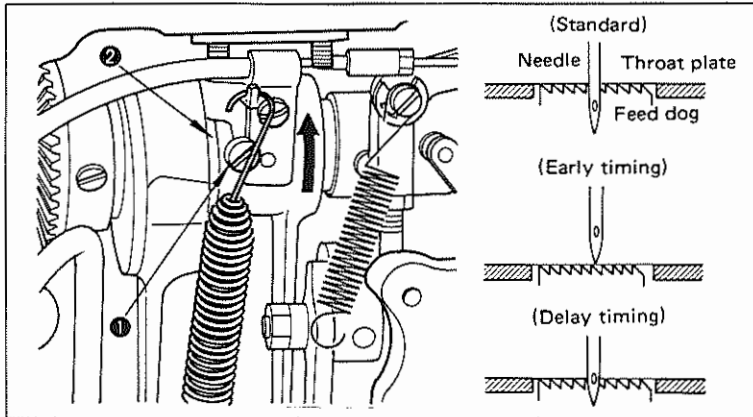

To obtain the standard feed timing, align the engraved line on the feed eccentric cam ① with the dot mark on thrust collar ②.

For adjustment the feed timing, loosen two setscrews ③, position the feed drive eccentric cam properly, and retighten the screws securely.

Move the feed drive eccentric cam in the direction of the arrow in order to speed up the feed timing to prevent irregular stitching (cloth slippage).

In order to delay the feed timing to ensure welltightened stitches, move the feed drive eccentric cam in the direction opposite to the arrow. At this time, be careful not to move the cam excessively, or else the needle may break.

## 17. HEIGHT OF THE FEED DOG

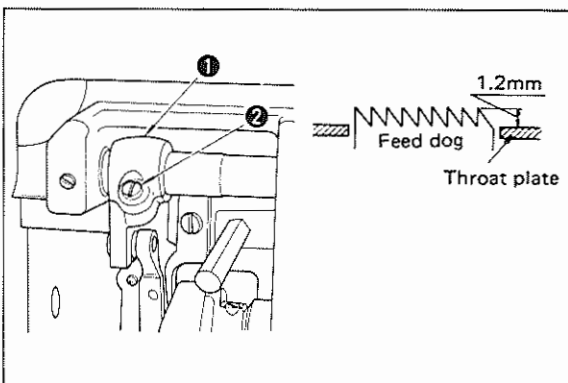

The feed dog is factory-adjusted so that it juts out 1.2 mm (3/64") from the throat plate surface.

To adjust the feed dog height;

1. Loosen clamp screw ② of feed rocker shaft crank ①.
2. Move the feed dog mounting base up or down to adjust the height of the feed dog.
3. Securely tighten the clamp screw.

## 18. NEEDLE-TO-HOOK RELATION

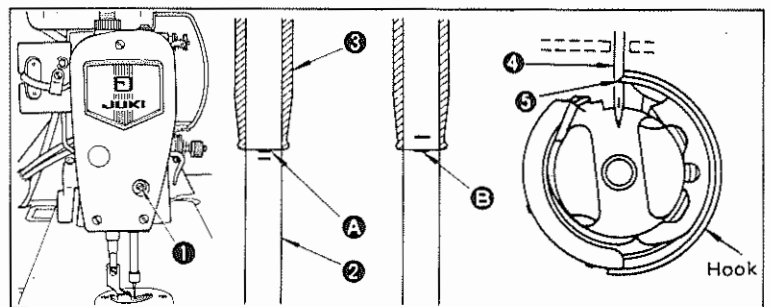

### ★ Arrange the needle and hook as follows

1. Turn the handwheel so that the needle bar comes down to its lowest position, and loosen needle bar connecting setscrew ①.

#### (Determine needle bar height)

2. Align upper marker line ④ engraved on needle bar ② with the bottom end of needle bar lower bushing ③, and tighten needle bar connecting setscrew ①.

#### (Positioning the hook)

3. Loosen the three hook setscrews, turn the handwheel and align the lower marker line ⑤ engraved on needle bar ② with the bottom end of needle bar lower bushing ③.
4. Under this condition, align blade point ⑤ of the hook to the center of needle ④, adjust the clearance between the needle and hook to 0.02 ~ 0.08 mm, and tighten the hook setscrew firmly.

## 19. ADJUSTING THE PRESSER BAR HEIGHT

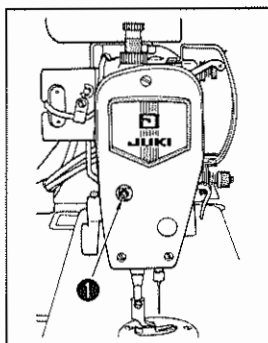

Change the presser bar height or presser foot angle after loosening needle bar connecting setscrew ①. After adjustment, tighten the setscrew firmly.

## 20. COUNTER KNIFE

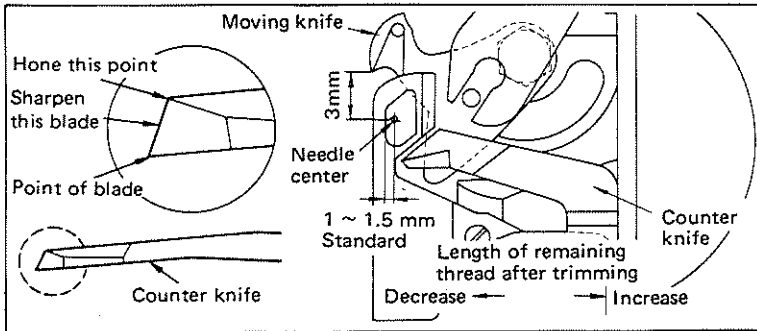

When the counter knife has become dull, sharpen it as early as possible, then reinstall it properly.

The counter knife is normally installed in the rightmost position.

As the fixing position of the counter knife is shifted to the left, the thread after trimming becomes shorter.

(Note) If the thread trimmer fails to sharply cut threads, the sewing machine may come to a halt while the trimmer is in operation.

## 22. ADJUSTING THE NEEDLE STOPPING POSITION FOR DDL-560-5

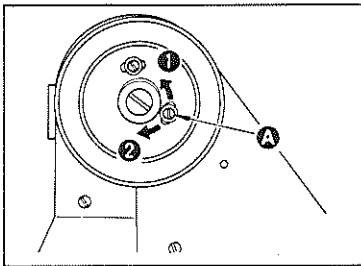

### ★ Upper stopping position after thread trimming

The standard needle stopping position can be obtained by aligning the red spot engraved on the machine arm with the white one on the handwheel. Stop the needle at the upper position, loosen screw **A**, and adjustment becomes possible;

i.e. when **A** is moved in the direction of **1**, the needle stopping position becomes lower, while if it is moved in the direction of **2**, it becomes higher.

(Note) 1. Take care not to operate the sewing machine with **A** left loosened. Do not remove screw **A** when loosening it.  
2. To check for correct needle stopping position, operate the machine with material and thread set on it, and check for alignment of the dots after thread trimming.

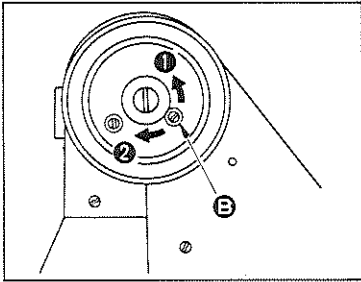

### ★ Lower stopping position

The lower stopping position of the needle when shifting the pedal position from forward treading to neutral, can be adjusted in a similar manner to above by loosening screw **B** after stopping the needle at the lower position; i.e. when shifting the handwheel toward **1**, the needle stopping position becomes higher, while if it is shifted toward **2**, it becomes lower.

(Note) Take care not to operate the sewing machine with screw **B** left loosened and not to remove screw **B** when loosening it.

## 25. POSITIONING FINGER

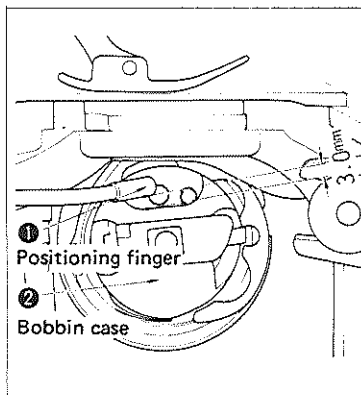

Normally, a 3 mm clearance is provided between positioning finger 1 and bobbin case 2.

(Precaution) Be careful not allow the end of the positioning finger to get into a hole in the bobbin. Align the rear end of the positioning finger with the marker line.

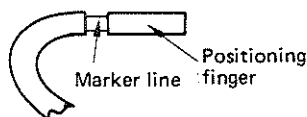

## 21. AMOUNT OF THREAD TO BE TAKEN UP

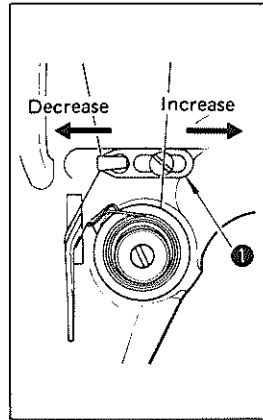

When sewing heavy-weight materials, move thread guide **1** to the left to increase the thread take-up amount. When sewing medium heavy-weight materials, move thread guide **1** to the right to decrease the thread take-up amount.

## 23. PEDAL PRESSURE AND STROKE

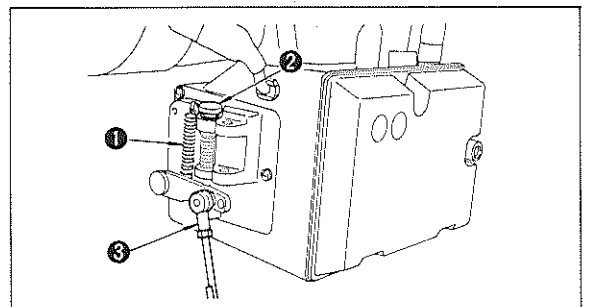

### ★ Adjusting the forward pedaling (toe down) pressure

The forward pedaling pressure can be adjusted by hooking adjusting spring **1** on the right or left side. When the spring is hooked on the left side, the pedal resistance reduces. When it is hooked on the right side the pedal resistance increases.

### ★ Adjusting the backward pedaling (heel down) pressure

This can be achieved by adjusting screw **2**. When the adjusting screw is tightened, the pedal resistance increases. When it is loosened, the pedal resistance reduces.

### ★ Adjusting the forward pedaling stroke

When connecting rod **3** is inserted into the hole on the left side, the stroke is reduced.

## 24. ADJUSTING THE PEDAL

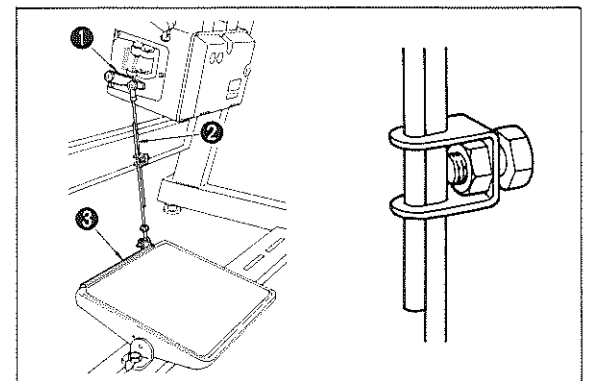

### ★ Attaching the connecting rod

Shift pedal adjusting plate **3** laterally so that connecting rod **2** and motor regulation lever **1** are aligned.

### ★ Pedal angle

The inclination of the pedal can be freely changed by adjusting the length of the connecting rod. This can be achieved by loosening the adjusting screw and moving the connecting rod.

## 26. ONE-TOUCH TYPE REVERSE STITCHING

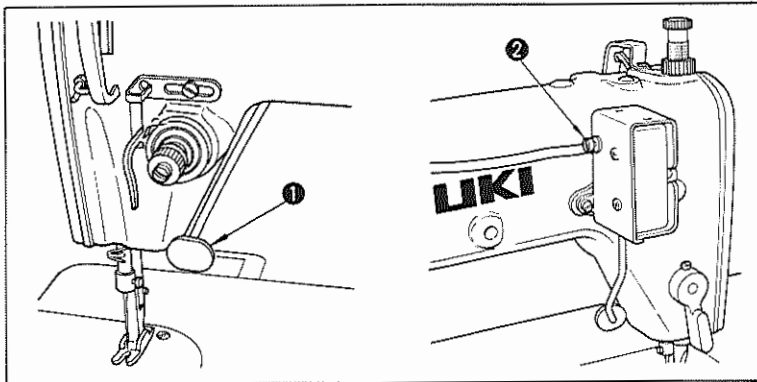

### ★ Operating method

1. If switch lever ① is pushed, the sewing machine immediately performs reverse stitching.
2. Reverse stitching is possible while the lever is kept pushed.
3. When the lever is released the sewing machine quickly returns to the normal feeding operation.

### ★ Height of switch lever

Adjust the height of switch lever ① to facilitate its use.

Loosen screw ②, move the lever vertically and adjust the height.

## 27. ADJUSTING THE THREAD TRIMMING SPEED (LOW SPEED) FOR DDL-560-5

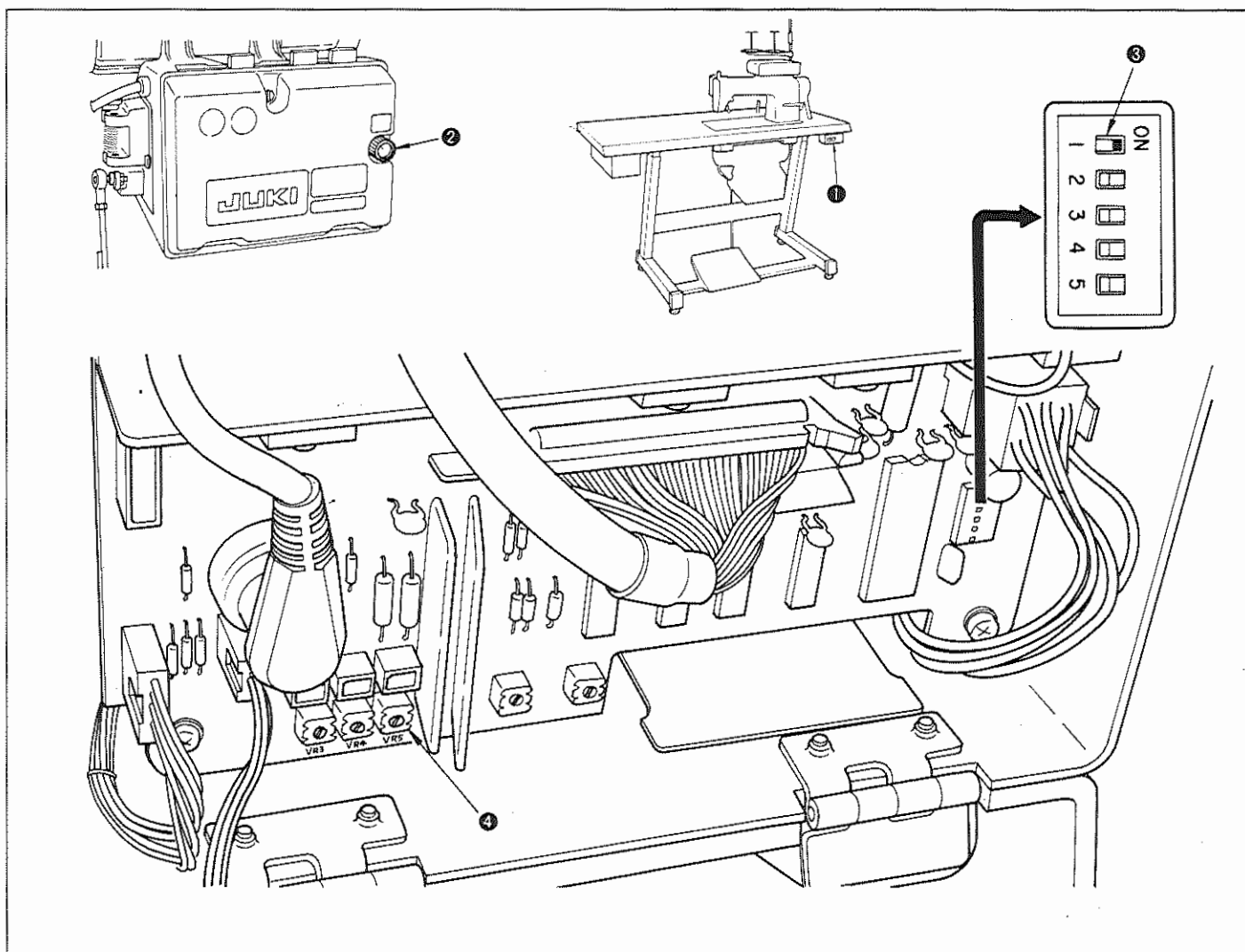

### ★ Adjustment procedure

The thread trimmer may fail to trim a thick thread due to slow sewing speed. If this happens, increase the thread trimming speed according to the following procedure:

1. Turn OFF the motor power switch ①.
2. Remove setscrew ② from the PSC box cover, and open the cover.
3. Set dip switch DSW1 ③ on the PSC circuit board to ON (to the right).
4. Raise the presser foot of the machine head, and hold it in the raised position using the presser lifter.
5. Turn the power switch ON.
6. Turn VR5 ④ to adjust the low speed to 225 to 245 s.p.m. (The speed increases when the VR5 is turned clockwise, and the speed decreases when it is turned counterclockwise.)  
 Note: When the MC-210 is used, the sewing speed is indicated on the CPU panel (Number of stitch display). Refer to "14" SEWING SPEED DISPLAY" of the instruction book for the MC-210.
7. After adjusting the sewing speed, turn the power OFF.
8. Set dip switch DSW1 ③ on the PSC circuit board to OFF (to the left).
9. Close the PSC box cover with care taken not to pinch a cord.

## 28. MOTOR PULLEY AND V BELT

1. Use Type-M V belts.
2. The relation between the motor pulley, belt length and sewing machine revolutions is as follows.

Outer diameter of the motor pulley	Part No. of motor pulley	Revolution		Belt length	Part No. of belt
		50 Hz	60 Hz		
75 mm	MTS-P00700A0	2,950 s.p.m.		40"	MTJ-VM004000
70 mm	MTS-P00650A0	2,750 s.p.m.			
65 mm	MTS-P00600A0	2,530 s.p.m.	3,030 s.p.m.		
60 mm	MTS-P00550A0	2,320 s.p.m.	2,780 s.p.m.		

(Note) The holes in the motor pulley are tapered. Therefore, commercially available pulleys cannot be used. The effective motor pulley diameter is obtained by subtracting 5 mm from the outer diameter. In the case of a single-phase motor, use belts which are one inch longer than those indicated in the table.

### (How to install)

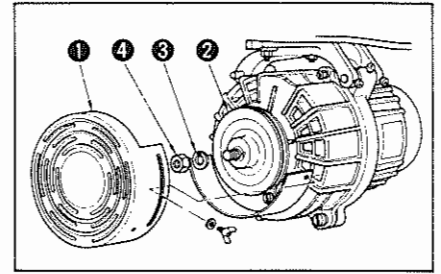

Remove pulley cover ①, and install motor pulley ② on the motor shaft, fitting it into the key way. Attach spring washer ③ to them, and tighten nut ④, using a wrench.

To remove motor pulley ②, take off the pulley cover, and reverse the installing procedure stated above. It is advisable to use a gear puller (Part No. J106500000), which is available at extra cost, to easily remove the motor pulley.

**(Caution)** When removing the motor pulley, do not hit it too hard with a hammer or the like, or else it may be damaged.

## 29. NEEDLE UPPER POSITION STOPPING SWITCH(optional attachment)

If it is necessary to stop the needle always in its highest position, a needle-up stop switch is available. When this switch is used, the handwheel make a half turn to make the needle stop in its highest position when the knee switch is pressed after the back part of the pedal is depressed for a stop during operation. (By setting the switch on the CPU panel, you can select whether or not the sewing machine should always stop with its needle in the highest position.)

## 30. SPECIFICATION

	DDL-560-5/DDDL-560-4
Fabric	Medium heavy-weight, heavy-weight materials
Sewing speed	3,000 s.p.m. (Max.)
Max. stitch length	7.5 mm (19/64") forward, 5 mm (13/64") reverse
Presser foot lift (by knee lifter)	13 mm (33/64")
Needle	DB x 1 #20 ~ #23, DP x 5 #19 ~ #23
Lubricating oil	JUKI New Defrix Oil No. 1

# 31. REPLACEMENT GAUGES

Throat plate (mm)	Feed dog (mm)	Presser foot (mm)	Application
D1109560E00	D1613560E00	Without finger guard B15240120A0 With finger guard B15240120BA	
			<p>Mounted on the machine head as the standard gauges. Effective for preventing filament threads from slipping off the needle at sewing start.</p>

Throat plate (mm)	Feed dog (mm)	Presser foot (mm)	Application
D1109560E0B	D1613560E00	Without finger guard D1524560EAB With finger guard D1524560EBB	
			<p>(Special-order gauges) Suitably used for a #23 needle or for a thick thread which tends to form loose stitches.</p>

Throat plate (mm)	Feed dog (mm)	Presser foot (mm)	Application
Without slots D1109555E0L With slots D1109555E0B	D1613555E0L	Without finger guard D1524555EAL With finger guard D1524555EBL	
			<p>(Special-order gauges) Effective for prevention of loose stitches when sewing coarse stitches with a thick thread.</p>

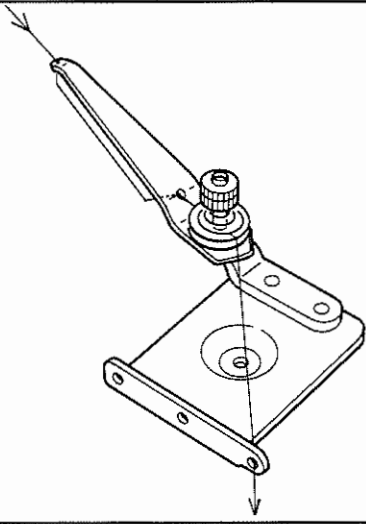
Thread guide plate (asm) (For DDL-560-5)	Application
D11113560EA0	<p>Ideally used for a filament thread which untwists easily, a twisted loop being caught between the tension discs.</p>
	



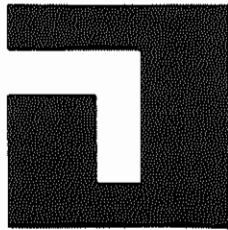

(Please do not hesitate to contact our distributors or agents  
in your area for further informations when necessary.)



**TOKYO JUKI INDUSTRIAL CO., LTD.**

Head Office & Plant: 2-1, 8-chome, Kokuryo-cho, Chofu-shi, Tokyo, Japan  
Business Office: 23-3, Kabuki-cho 1-chome, Shinjuku-ku, Tokyo 160, Japan  
Cable: JUKI TOKYO Telex: J22967, 232-2301  
Phone: 03(205)1188, 1189, 1190

Appear and specification listed in this instruction book are subjected to change without notice.

1986. 8 Printed in Japan(T)