

**CP-130****INSTRUCTION MANUAL**

Congratulations on your purchase of a JUKI control panel. To get the most out of many functions of the control panel, it is necessary to use the unit correctly, so please read this Instruction Manual carefully before using it. We hope you will enjoy using it for a long time.

**GENERAL**

The CP-130 of control panel achieves many different features when used with the sewing machine controller.

**(Caution)** The CP-130 of control panel is not interchangeable with our SC Series of control panel (SC-120, -220 and -320). If any of these SC Series of control panel instead of the CP-130, it will not function and may break itself and the main unit of the sewing machine controller.

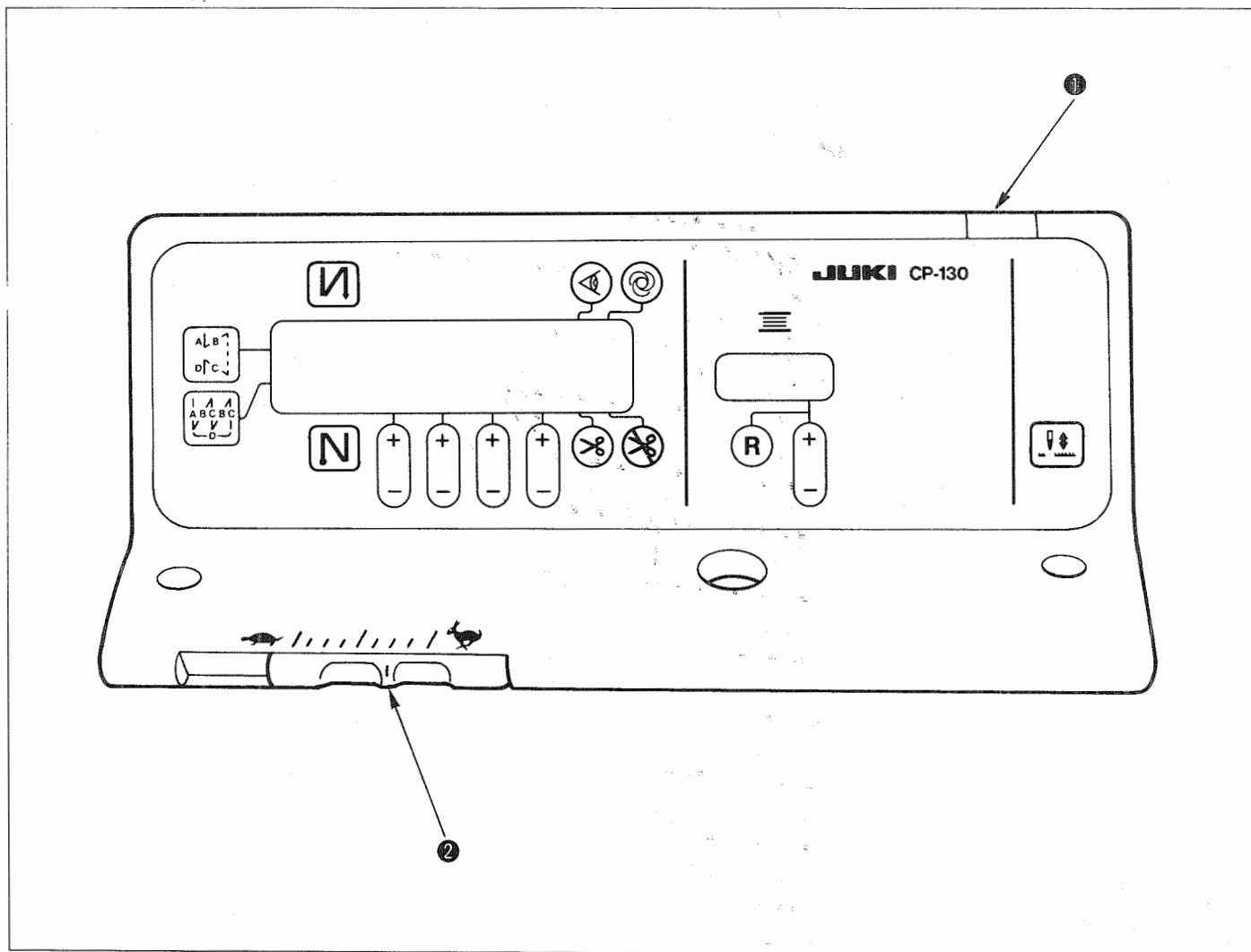
**1. CONFIGURATION**

- ① Power indicator lamp (LED): Lights up when the power switch is turned ON.
- ② Max. speed limitation variable resistor: Limits the speed when it is moved to the left ( ← ).

## 2. CONTROL PANEL

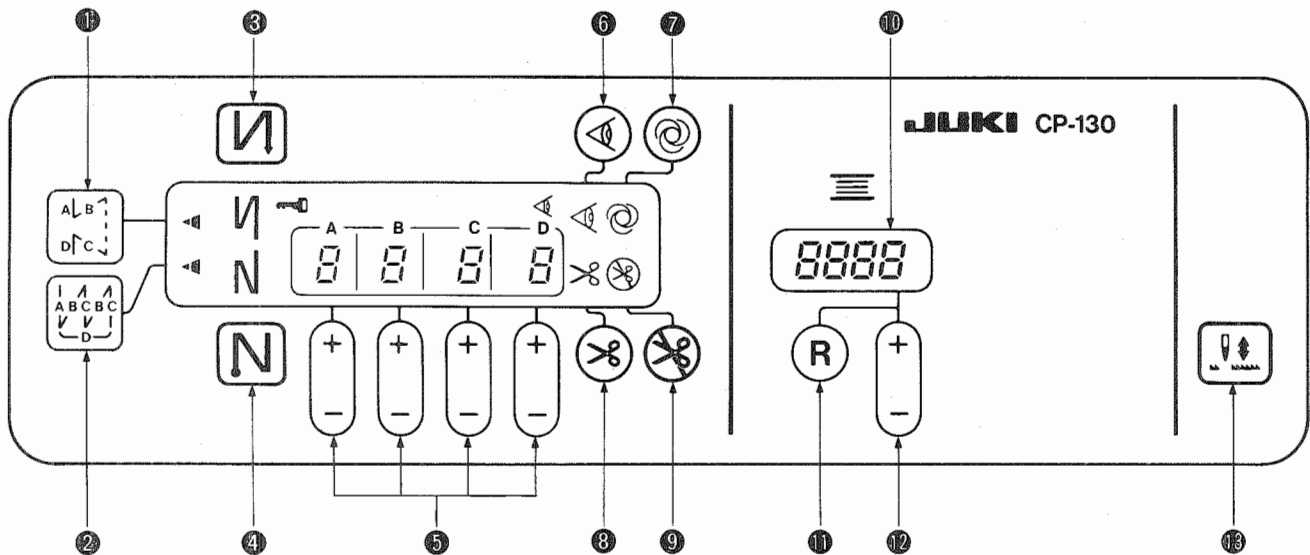

(All the indications on the control panel are illustrated in the lip-up state for the sake of explanation.)

### ① Reverse stitching pattern switch

- Used for specifying the reverse stitching pattern to be sewn.

### ② Overlapped stitching pattern switch

- Used for specifying the overlapped stitching pattern to be sewn.

### ③ Automatic reverse stitching (for start) switch

- Used for turning ON/OFF the automatic reverse stitching for start.

### ④ Automatic reverse stitching (for end) switch

- Used for turning ON/OFF the automatic reverse stitching for end.

### ⑤ Switches for setting the number of stitches

- Used for setting the number of stitches to be sewn in processes A through D.

### ⑥ Material edge sensor ON/OFF switch

- Rendered effective when the material edge sensor is installed on the machine.
- Used for setting whether or not the material edge sensor is used during sewing.

### ⑦ One-shot automatic stitching switch

- This switch becomes effective when the control panel is used in combination with the material edge sensor.
- When this switch is turned ON, it is possible to make the sewing machine automatically perform sewing until the end of the process is reached only by driving the sewing machine once.

### ⑧ Automatic thread trimming switch

- This switch becomes effective when the control panel is used in combination with the material edge sensor.
- If this switch is turned ON, the machine will proceed to the thread trimming process when the material edge is detected, even when the front part of the pedal is held depressed.

### ⑨ Thread trimming prohibition switch

- Used for prohibiting thread trimming at any occasion.

### ⑩ Bobbin thread counter

- Indicates the amount of bobbin thread while counting it by subtracting from the set value.
- When the bobbin thread remaining amount detecting device is installed on the machine, the counter indicates the number of times of detecting.

### ⑪ Bobbin counter reset switch

- Used for returning the value shown on the bobbin thread counter to the initial value.

### ⑫ Bobbin thread amount setting switch

- Used for setting the amount of bobbin thread.

### ⑬ Needle up/down compensating switch

- Used when performing needle up/down compensating stitching.

**(1) Reverse stitching pattern**

Aytomatic reverse stitching (for start) switch ②	OFF	ON	OFF	ON
Sewing pattern				
Automatic reverse stitching (for end) switch ③	OFF	OFF	ON	ON

- 1) Press reverse stitching pattern switch ① to specify the reverse stitching pattern.
- 2) The reverse stitching pattern is selected. Now, the predetermined number of stitches and ON/OFF state of automatic reverse feed stitching (for start) switch ② and automatic reverse feed stitching (for end) switch ③ are indicated on the control panel.

- 3) If you want to change the number of stitches, operate the "+" or "-" switch of switches ④ for setting the number of stitches A through D.  
(The range of the number of stitches that can be changed : 0 to 9 stitches)
- 4) Four different stitching patterns can be performed by matching the ON and OFF settings of automatic reverse stitching (for start) switch ② and automatic reverse stitching (for end) switch ③.

**(2) Overlapped stitching pattern**

- 1) Press overlapped stitching pattern switch ① to specify the overlapped stitching pattern.
- 2) The overlapped stitching pattern is selected, and the number of stitches and data on overlapped stitching which have already been specified are shown on the panel.

- 3) If you want to change the number of stitches, operate the "+" or "-" switch of switches ② for setting the number of stitches for processes A through C. If you want to change the number of whole processes, operate the "+" or "-" switch of switch ③ for setting the number of processes D.  
(The range of the number of stitches A, B and C that can be changed : 0 to 9 stitches) (The range of the number of processes D that can be changed : 0 to 9 times)
- 4) Depress the front part of the pedal once, and the sewing machine will repeat the normal stitching and reverse stitching by the predetermined time. Then, the sewing machine will automatically make the thread trimmer actuate and will stop to complete the overlapped stitching procedure. (The one-shot automatic stitching cannot be turned OFF.)
- 5) If thread trimming prohibiting function ④ is chosen, the machine will stop with the needle up upon completion of the overlapped stitching procedure without performing thread trimming.

## 4. HOW TO USE THE BOBBIN THREAD COUNTER

The machine detects the number of stitches. The preset value on the bobbin thread counter is subtracted in accordance with the number of stitches detected. (Every time the detector detects 10 stitches, 1 is subtracted from the preset value on the bobbin thread counter.) When the value on the counter becomes a minus value as "1 → 0 → -1," the buzzer beeps three times to warn the operator that the time to change the bobbin thread has come.

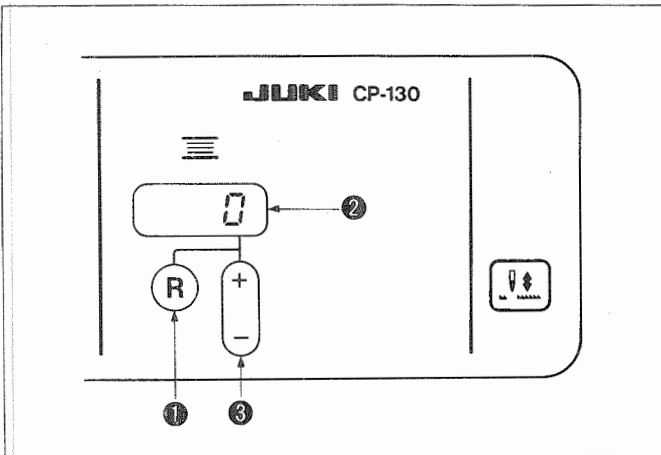

- 1) Press bobbin thread counter reset switch ① to return the value indicated on bobbin thread counter ② to the initial value (it has been factory-set to "0" at the time of delivery).
- (Caution) **The bobbin thread counter cannot be reset during sewing. In this case, make the thread trimmer actuate once.**
- 2) Specify an initial value using bobbin thread amount setting switch ③.

< Initial value on the bobbin thread counter for reference >

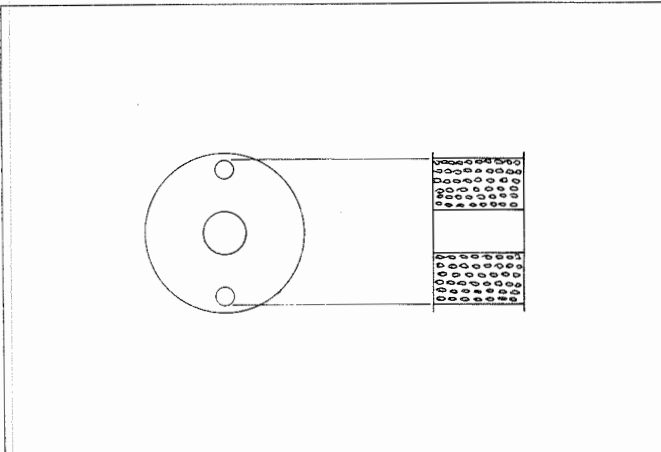

The table below gives the initial setting values for reference when the bobbin is wound with thread to the extent that the pinhole in the outside of the bobbin case is reached as shown in the figure given above.

Thread	Length of thread wound round the bobbin	Value on bobbin thread counter
Spun thread #50	36 m	1200 (stitch length : 3 mm)
Cotton thread #50	31 m	1000 (stitch length : 3 mm)

Thread tension rate 100 %

\* Actually, the bobbin thread counter is affected by the material thickness and the sewing speed. So, adjust the initial value of the bobbin thread counter in accordance with the operating conditions.

(Caution) If the bobbin thread counter is used in combination with the bobbin thread remaining amount detecting device, the bobbin thread counter indicates the number of detections of the bobbin thread remaining amount detecting device. So, be sure to use the device after carefully reading the Instruction Manual for the bobbin thread remaining amount detecting device.

- 3) Once the initial value is specified properly, start the sewing machine.
- 4) When a minus value is shown on the counter and the buzzer beeps three times, replace the bobbin thread.
- 5) After the bobbin thread has been properly replaced, press bobbin thread counter reset switch ① to return the value on the bobbin thread counter to the initial value. Now, re-start the sewing machine.
- 6) If the remaining amount of bobbin thread is excessive or the bobbin thread runs out before the bobbin thread counter indicates a minus value, and the initial value appropriately using the "+" or "-" switch of bobbin thread amount setting switch ③ .  
 If the remaining amount of bobbin thread is excessive  
 ..Increase the initial value using the "+" switch.  
 If the remaining amount of bobbin thread is insufficient  
 ..Decrease the initial value using the "-" switch.

Every time needle up/down compensation switch ① is pressed, the needle goes up when it is in its lowest position or comes down when it is in its highest position. This compensates the stitch by a half of the predetermined stitch length. However, note that the machine does not run continuously at a low speed even if you keep the switch pressing. The trimming is operative only at the time of stitch compensation after depressing the front part of the pedal once.

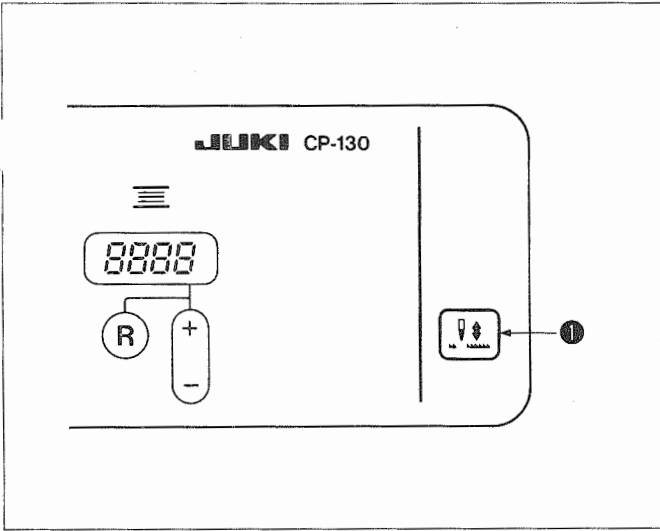

## 6. KEY LOCK FUNCTION

In order to prevent the specified data on the number of stitches or the processes (A, B, C and D) to be changed by mistake, the setting switch can be locked. (Even with the setting keys locked, the pattern to be sewn and the value on the bobbin thread counter can be changed.)

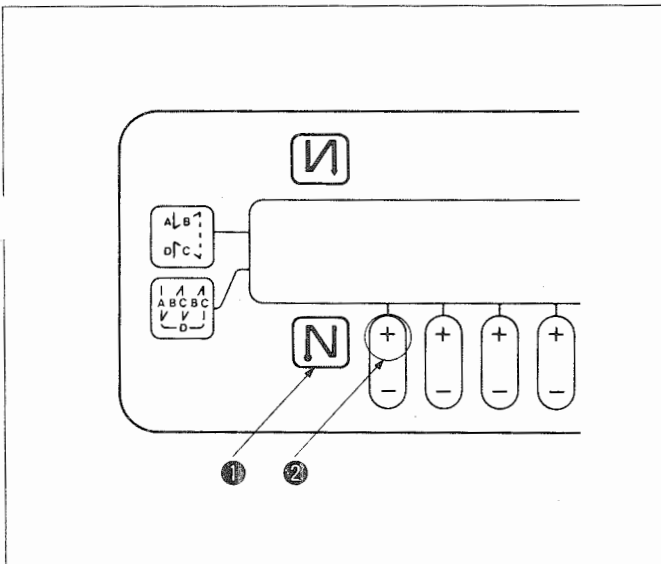

- 1) After the completion of the setting of data on the number of stitches, etc., turn OFF the power to the machine once.
- 2) Turn ON the power switch while simultaneously pressing automatic reverse stitching (for end) switch ① and the "+" switch of number of stitches setting switch ② for process A with fingers.
- 3) Key mark ③ is shown on the control panel. This completes the locking of keys.

(If the key mark is not shown on the control panel, carry out the aforementioned steps 1) through 3) again.)

- \* To release the keys from the locked state, perform the aforementioned steps 1) and 2). (Once the key mark goes out, the keys are released from the locked state.)

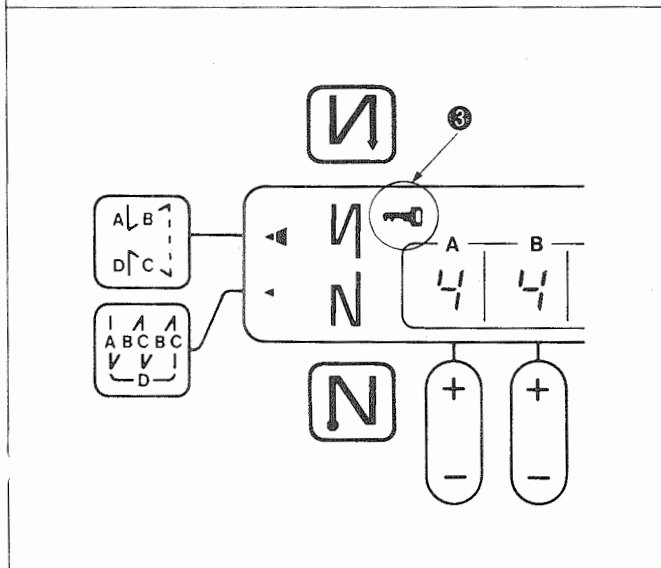

## 7. ON/OFF SWITCH ◀ OF THE MATERIAL EDGE SENSOR

- When the material edge sensor, which is optionally available, is connected to the control panel, the ON/OFF switch of the material edge sensor becomes effective.
  - If the material edge sensor is specified, the sewing machine will automatically stop running or perform thread trimming when the sensor detects the material edge.
- (Caution) If the material edge sensor is used in combination with the control panel, carefully read the Instruction Manual for the material edge sensor beforehand.

## 8. AUTOMATIC THREAD TRIMMING SWITCH ⊗

- This switch is used to automatically actuate the thread trimmer in a process where the sewing machine automatically stops or when the material edge sensor is used.  
(If the automatic reverse stitching (for end) is specified, the thread trimmer will actuate after the sewing machine completes the automatic reverse stitching (for end).)

## 9. ONE-SHOT AUTOMATIC STITCHING SWITCH ©

- This switch is used, in the overlapped stitching mode or in the process where the material edge sensor is specified, to make the sewing machine automatically perform sewing at the specified speed until the end of the process is reached only by driving the sewing machine once.

## 10. THREAD TRIMMING PROHIBITION SWITCH ⊗

- This switch is used to temporarily make the thread trimming function inoperative.  
The other performance of sewing machine is not affected by this switch.  
(If the automatic reverse stitching (for end) is specified, the sewing machine will perform the automatic reverse stitching at the end of sewing.)
- If the automatic thread trimming switch ⊗ and the thread trimming prohibition switch ⊗ are both specified, the machine will not perform thread trimming but stop with its needle up.

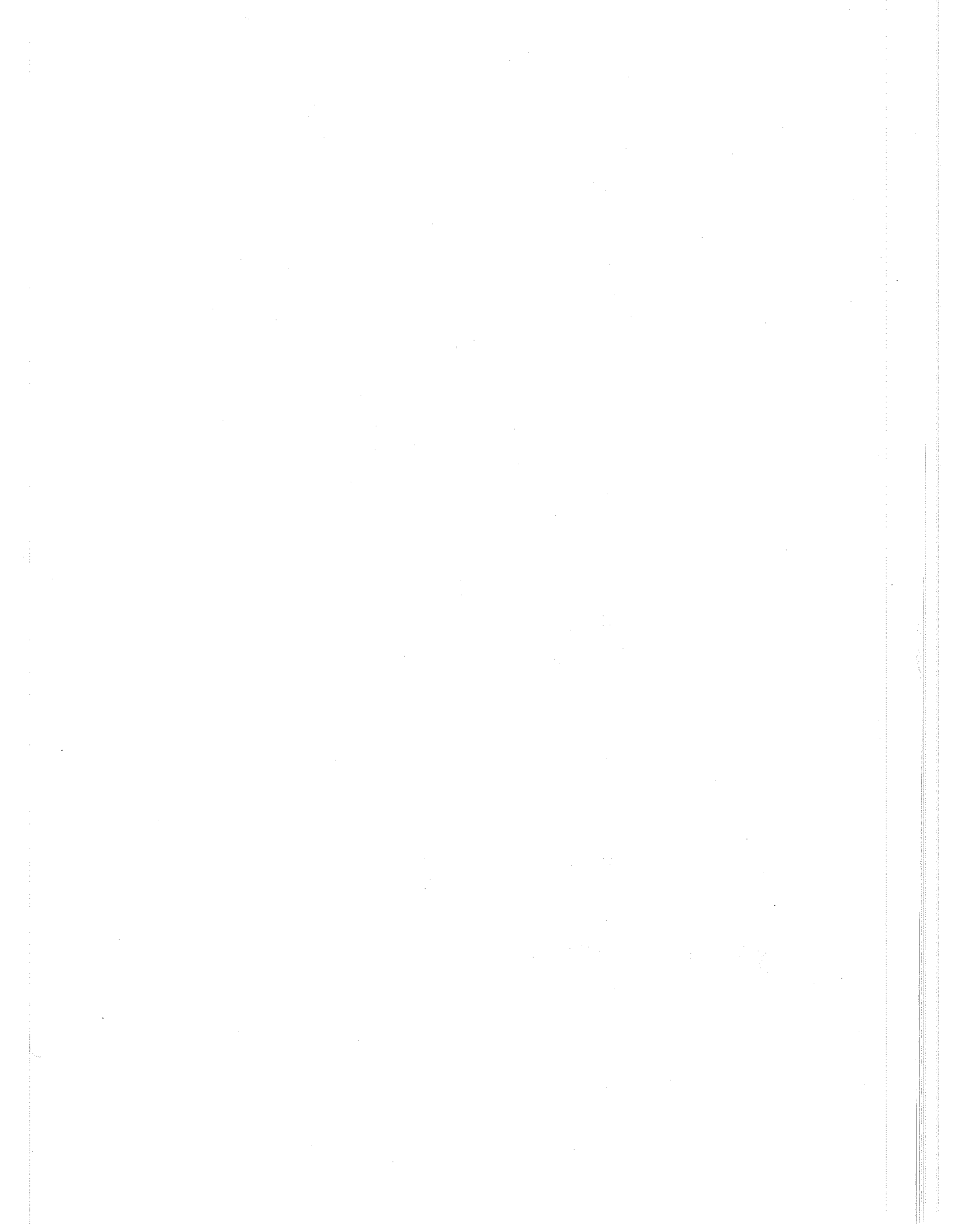

**JUKI**

**JUKI CORPORATION**

**INTERNATIONAL SALES DIVISION**

8-2-1, KOKURYO-CHO,  
CHOFU-SHI, TOKYO 182, JAPAN

PHONE : 03 (3430) 4001~5

FAX : 03 (3430) 4903. 4909. 4914

TELEX : J22967

To order or for further information, please contact :

Please do not hesitate to contact our distributors or agents in your area for further information when necessary.  
\*The description covered in this instruction manual is subject to change for improvement of the commodity without notice.