

APW-195N

取扱説明書 使用説明書

INSTRUCTION MANUAL

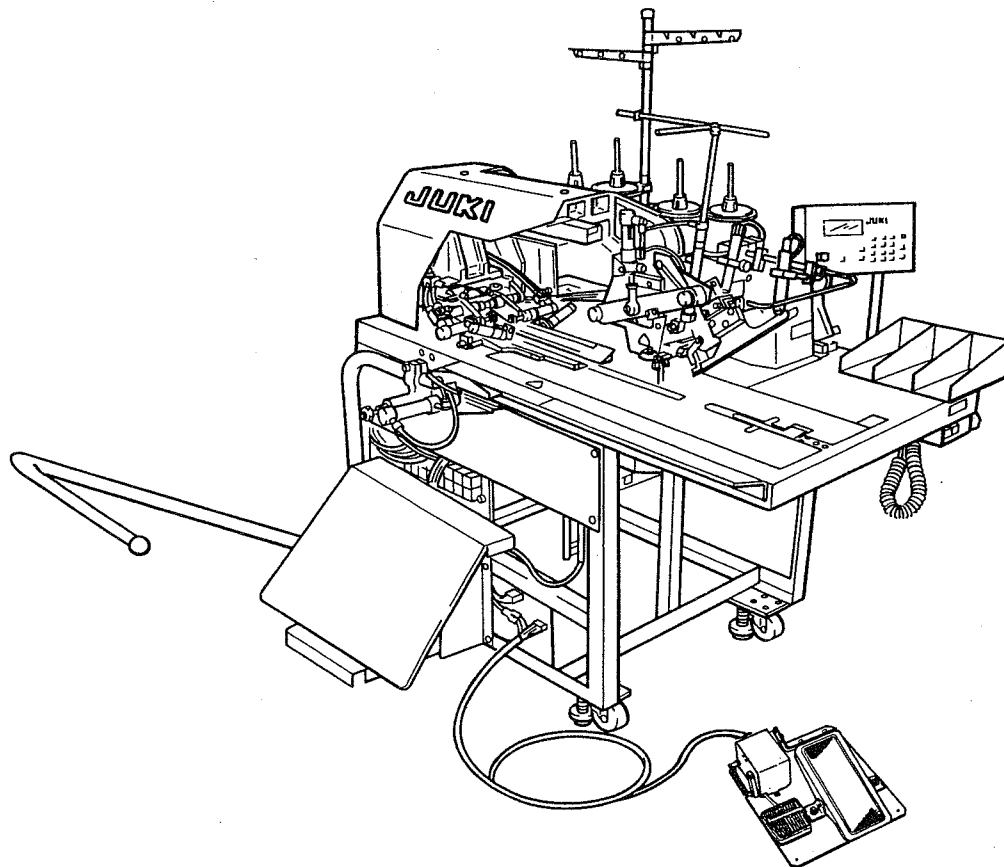

このたびは、当社の製品をお買い上げいただきまして、ありがとうございました。
安全に使用していただくために使用前に、必ずこの取扱説明書をお読みください。
また、いつでもすぐに読めるように、この取扱説明書を保管してください。

Read safety instructions carefully and understand them before using.
Retain this Instruction Manual for future reference.

為了安全地使用，請您在使用之前一定閱讀本使用說明書。
另外，請您注意保管本使用說明書，以便隨時查閱。

IMPORTANT SAFETY INSTRUCTIONS

Putting sewing systems into operation is prohibited until it has been ascertained that the sewing systems in which these sewing machines will be built into, have conformed with the safety regulations in your country. Technical service for those sewing systems is also prohibited.

1. Observe the basic safety measures, including, but not limited to the following ones, whenever you use the machine.
2. Read all the instructions, including, but not limited to this Instruction Manual before you use the machine. In addition, keep this Instruction Manual so that you may read it at anytime when necessary.
3. Use the machine after it has been ascertained that it conforms with safety rules/standards valid in your country.
4. All safety devices must be in position when the machine is ready for work or in operation. The operation without the specified safety devices is not allowed.
5. This machine shall be operated by appropriately-trained operators.
6. For your personal protection, we recommend that you wear safety glasses.
7. For the following, turn off the power switch or disconnect the power plug of the machine from the receptacle.
 - 7-1 For threading needle(s), looper, spreader etc. and replacing bobbin.
 - 7-2 For replacing part(s) of needle, presser foot, throat plate, looper, spreader, feed dog, needle guard, folder, cloth guide etc.
 - 7-3 For repair work.
 - 7-4 When leaving the working place or when the working place is unattended.
 - 7-5 When using clutch motors without applying brake, it has to be waited until the motor stopped totally.
8. If you should allow oil, grease, etc. used with the machine and devices to come in contact with your eyes or skin or swallow any of such liquid by mistake, immediately wash the contacted areas and consult a medical doctor.

9. Tampering with the live parts and devices, regardless of whether the machine is powered, is prohibited.
10. Repair, remodeling and adjustment works must only be done by appropriately trained technicians or specially skilled personnel. Only spare parts designated by JUKI can be used for repairs.
11. General maintenance and inspection works have to be done by appropriately trained personnel.
12. Repair and maintenance works of electrical components shall be conducted by qualified electric technicians or under the audit and guidance of specially skilled personnel.
Whenever you find a failure of any of electrical components, immediately stop the machine.
13. Before making repair and maintenance works on the machine equipped with pneumatic parts such as an air cylinder, the air compressor has to be detached from the machine and the compressed air supply has to be cut off. Existing residual air pressure after disconnecting the air compressor from the machine has to be expelled. Exceptions to this are only adjustments and performance checks done by appropriately trained technicians or specially skilled personnel.
14. Periodically clean the machine throughout the period of use.

15. Grounding the machine is always necessary for the normal operation of the machine. The machine has to be operated in an environment that is free from strong noise sources such as high-frequency welder.
16. An appropriate power plug has to be attached to the machine by electric technicians. Power plug has to be connected to a grounded receptacle.

17. The machine is only allowed to be used for the purpose intended. Other used are not allowed.
18. Remodel or modify the machine in accordance with the safety rules/standards while taking all the effective safety measures. JUKI assumes no responsibility for damage caused by remodeling or modification of the machine.

19. Warning hints are marked with the two shown symbols.





Danger of injury to operator or service staff



Items requiring special attention

FOR SAFE OPERATION

| | |
|---|---|
|  | <p>1. To avoid electrical shock hazards, neither open the covers of the motor the electrical box and the operation panel nor touch the components mounted inside the electrical box and the operation panel.</p> |
|  | <ol style="list-style-type: none">1. Don't put your hand under the needle when you turn ON the power switch or operate the machine.2. The clamp feet move at a high speed when the foot pedal is depressed. Do not put hands, fingers, face, etc. within the moving range of the clamp feet while placing the foot on the pedal.3. Turn OFF the power switch before tilting the machine head or removing the V belt.4. To protect against possible danger, never place your fingers or hair in the handwheel, V belt, bobbin winder wheel, motor and any other driving part while the machine is in operation. In addition, place nothing near them.5. If any of the following phenomena should arise, immediately turn OFF the power switch and have a maintenance personnel inspect the machine.<ol style="list-style-type: none">① In the case where needle breakage or thread breakage frequently arise② In the case where the machine exhibits irregular behavior6. Do not turn OFF the power supply or air supply while the machine is in operation.7. Do not shift the clamp foot with the sewing table opened.8. Do not turn ON the clamp foot travel switch on the operation panel with the clamp foot back end detecting switch, rear removed.9. Be sure to connect the FG wire of the power cable to the earth of the main power source.10. Do not place anything that might generate a high heat/humidity around the electrical box.11. Do not shift the corner knife with the cover removed.12. Use welt patches reinforced with adhesive interlining. |

CONTENTS

| | |
|--|----|
| CAUTIONS BEFORE OPERATION | 1 |
| I. NAMES OF SWITCHES | 2 |
| II. SPECIFICATIONS | 3 |
| 1. MECHANICAL SPECIFICATIONS | 3 |
| 2. ELECTRICAL SPECIFICATIONS | 3 |
| III. INSTALLATION | 4 |
| (1) Securing the machine | 4 |
| (2) Attaching the stacker safety pipe | 4 |
| (3) Connecting the foot pedal | 4 |
| (4) Connecting the air coupler | 4 |
| (5) Connecting the power plug | 5 |
| (6) Assembling the thread stand and attaching it to the machine | 5 |
| IV. PREPARATION AND OPERATION | 6 |
| 1. HOW TO OPERATE THE SEWING MACHINE HEAD | 6 |
| (1) How to attach the needles | 6 |
| (2) Types of thread | 6 |
| (3) How to thread the machine | 7 |
| 2. HOW TO REMOVE THE SEWING TABLE | 8 |
| (1) When changing the bobbin thread | 8 |
| (2) Cautions to be taken when the sewing tables are removed | 8 |
| 3. HOW TO WIND THE BOBBINS | 9 |
| 4. ADJUSTING THE BOBBIN THREAD AMOUNT TO BE WOUND ROUND THE BOBBIN | 9 |
| 5. HOW TO THREAD THE BOBBIN CASE | 9 |
| 6. HOW TO INSTALL THE BOBBIN CASE | 10 |
| 7. HOW TO ADJUST THE THREAD TENSION | 10 |
| 8. PEDAL SWITCH | 11 |
| 9. OPERATION PANEL SWITCHES AND INDICATOR LAMPS | 12 |
| (1) Operation panel switches | 12 |
| (2) Manual mode and automatic mode | 15 |
| (3) Example of setting data on cycle sewing | 34 |
| V. MAINTENANCE | 36 |
| 1. INSPECTION | 36 |
| (1) Maintenance and inspection of the pneumatic systems | 36 |
| (2) Maintenance and inspection of the sewing machine components | 36 |
| (3) Maintenance and inspection of the electrical systems | 36 |
| 2. CROSS MARK LAMPS | 37 |
| (1) Cross (+) mark lamps for setting sewing | 37 |
| 3. LUBRICATION | 38 |
| (1) Lubrication of the face plate | 38 |
| (2) Lubrication of the hooks | 38 |
| 4. HOW TO CHANGE OVER THE TYPE OF WELT; DOUBLE-WELT, SINGLE-WELT OR VARIABLE DOUBLE-WELT | 39 |
| (1) Binder components | 39 |
| (2) Clamp foot components | 39 |
| (3) Switching the folding plate | 39 |
| 5. HOW TO ADJUST THE FOOT PEDAL | 40 |
| 6. SPECIFYING THE SENSITIVITY OF THE SENSOR AMPLIFIER FOR DETECTING FLAPS | 41 |
| 7. ADJUSTING THE SENSITIVITY OF THE AMPLIFIER OF THE BOBBIN THREAD REMAINING AMOUNT DETECTING SENSOR | 42 |
| 8. CAUSES AND CORRECTIVE MEASURES AGAINST TROUBLES WITH THE BOBBIN THREAD REMAINING AMOUNT DETECTING DEVICE | 42 |
| 9. EXPLANATION OF VARIABLE RESISTORS AND DIP SWITCHES | 43 |
| (1) Explanation of function | 43 |
| (2) How to use the DIP switches | 44 |
| VI. LIST OF ALARM CODES | 45 |
| VII. LIST OF CHECK CODES | 48 |
| VIII. SEWING DATA SHEET | 50 |

CAUTIONS BEFORE OPERATION

Following items have to be checked every working day before the operation of the machine and before the start of work hours.

1. Ascertain that the sewing machine is filled with the predetermined amount of oil.
2. Never operate the machine unless the lubricating part in the hook has been filled up with oil.
3. Check the direction of rotation of the motor of the machine before operating the machine. (When the power switch is turned ON with the needle bar in its lowest position, the handwheel turns toward you and stops when the highest position of the needle bar is reached.)
4. Ascertain that the pressure gauge indicates 0.5 MPa. *(This is necessary particularly when the compressor is stopped for a lunch break or the like.)
5. Check whether the needle thread/bobbin thread need to be replenished.
6. To perform sewing immediately after turning ON the power switch. Perform trial stitching first, then proceed with sewing of actual products after the test sewing.
7. Remove any dust from the lens surface of the cross marking lamp.
8. Ascertain that the machine is in the home position when turning ON the power to the machine.
 - ① The binder is in the highest position.
 - ② The clamp foot is in the highest position.
9. In order to protect the optical fiber sensor of the bobbin thread remaining amount detecting device from showing a detecting failure, be sure to clear the area around the hook of thread waste using an air gun once or more times a day.
10. In order to protect the flap sensor from showing a detecting failure, be sure to clear the surface of the reflecting tape of the folding plate of dust using an air gun once or more times a day.
11. In order to prevent a rise in the temperature of the sewing machine motor, be sure to remove dust gathering on the rear filter of the sewing machine motor using an air gun once or more times a day.

I. NAMES OF SWITCHES

The APW-195N consists mainly of the following units ;

- Ⓐ Frame and structural components
(Frame, sewing table, covers, foot switch etc.)
- Ⓑ Clamp foot unit and feed mechanism
- Ⓒ Corner knife unit
- Ⓓ Binder unit (Binder components and its driving components)
- Ⓔ Pneumatic control unit (Pneumatic control devices and pipings)
- Ⓕ Stacker unit
- Ⓖ Sewing machine head
- Ⓗ Electric control unit (Control panel)
- Ⓘ Oil pan
- ⓵ Operation panel
- ⓷ Power switch

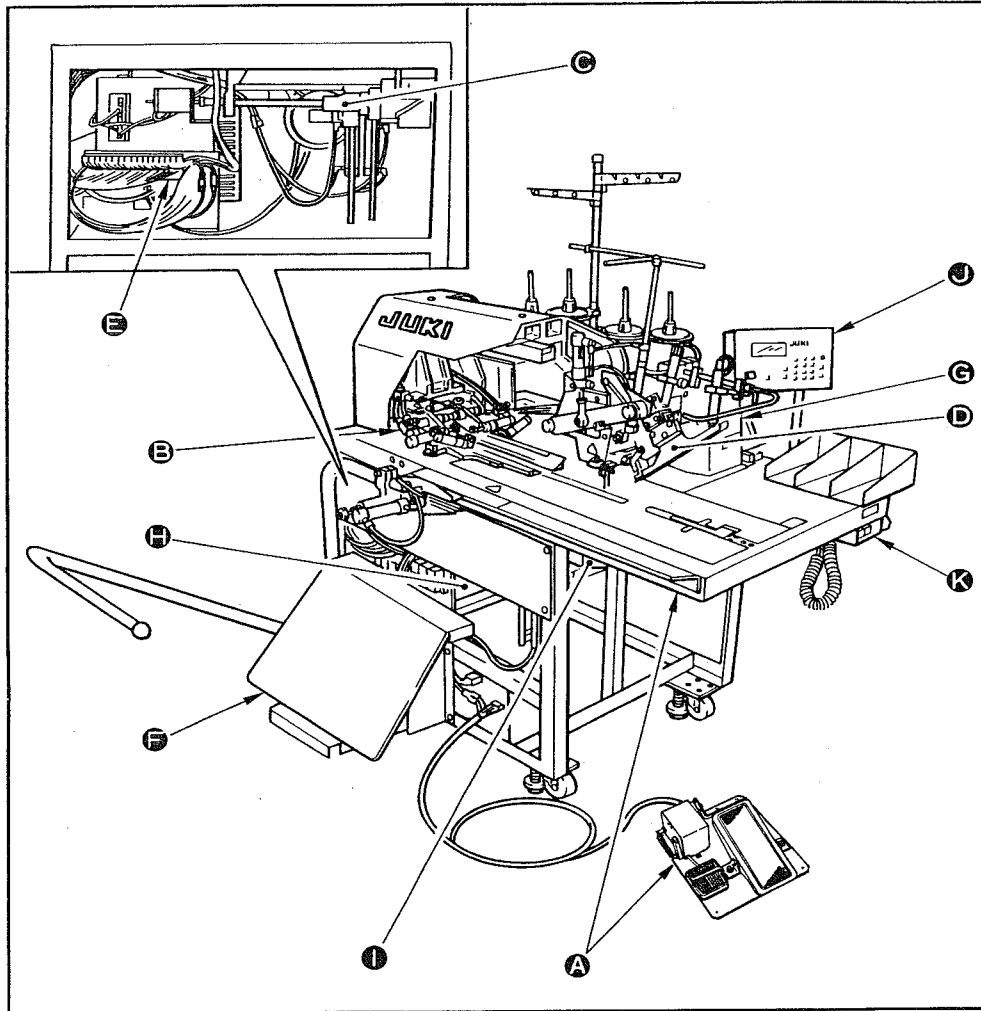

With this machine, you can do desired welting work simply by setting materials (garment body, interlining piece, welting patch etc.) in place and operating the switches on the operation panel.

II. SPECIFICATIONS

1. MECHANICAL SPECIFICATIONS

- Sewing machine: 2-needle, lockstitch machine with center knife LH-585
- Sewing speed: 2,500 rpm (standard)
- Stitch length: Lockstitch: 2.0 to 3.4 mm (standard: 2.0 mm)
Condensation stitch: 0.5 to 1.5 mm (standard: 1.0 mm) } Condensation/Back tack stitch
Back tack stitch: 0.5 to 3.4 mm (standard: 2.0 mm) } selectable
- Types of welt: Parallel double welt, parallel single welt, } Each with flap
parallel variant double welt, combined single welt. } or without flap
- Pocket lip length: Possible to set in increments of 1 mm within the range of 35 mm (min.) to 180 mm (max.)
(Welt length) (needle gauge 8 to 12 mm)
Possible to set in increments of 1 mm within the range of 50 mm (min.) to 180 mm (max.)
(needle gauge 14 to 20 mm)
- Welting width (needle gauge): 8, 10, 12, 14, 16, 18 and 20 mm
- Needles: ORGAN Mt × 190 #16 to #18 (standard #16)
SCHMETZ 190R #100 to #110 (standard #100)
- Thread: Spun thread #50 (recommended)
- Hook: Full rotary, vertical-axis, self-lubrication hook
- Thread take-up lever: Slide thread take-up lever
- Needle bar stroke: 34.4 mm
- Cloth feed mechanism: Driven by servomotor
- Control: By a micro-computer
- Safety mechanism: Machine operation is automatically stopped if the cloth feed mechanism error detector and, the needle thread breakage detector or any of the various safety devices are actuated.
- Lubricating oil: JUKI New Defrix Oil No. 2
- Operating air pressure: 0.5 MPa
- Air consumption: Approx. 40 Nℓ/min.
- Dimensions of the machine: 735 mm (width) × 1,250 mm (length) × 1,200 mm (height)
(1,400 mm ... when including the stacker) (1,500 mm ... when including the thread stand)
- Weight: Approx. 200 kg

2. ELECTRICAL SPECIFICATIONS

Once the required data is set by means of a built-in micro-computer, the data can be stored in memory (for 100 hours) using a built-in battery even after turning OFF the power to the machine unless the data is canceled.

- Input power: 3-phase 200, 220, 230, 240, 380, 400, 415, 440 } 50/60Hz
Single-phase 200, 220, 230, 240 }
Voltage fluctuation: Within ± 10% of the rated voltage
- Power consumption: 500 W

III. INSTALLATION

(1) Securing the machine

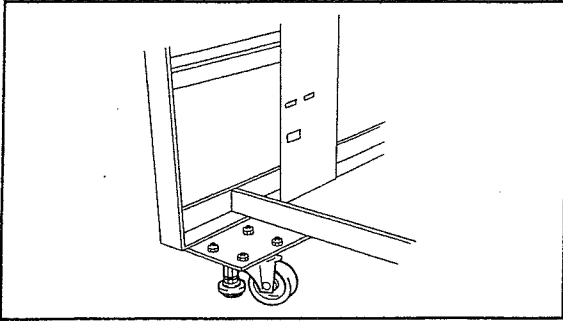

To protect against possible personal injuries, move the machine to a stable place that is level-in-surface and fix it there by lowering four adjuster bolts locating next to the casters.

(2) Attaching the stacker safety pipe

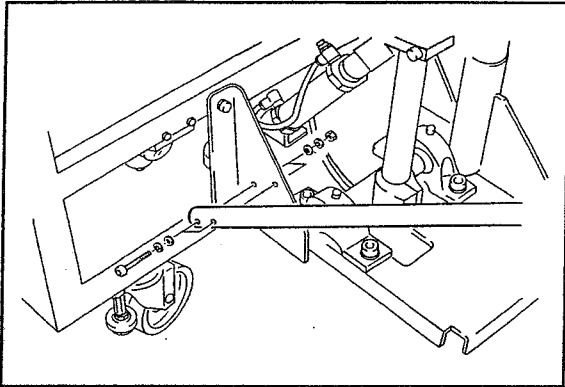

To protect against possible personal injuries, attach the safety pipes to the stacker using the screws.

(3) Set-up of the bar stacker (optional)

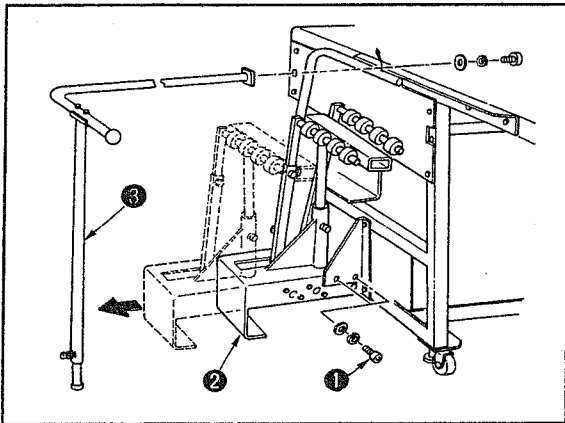

Bar stacker ② has been delivered with stored in the main unit frame. To put it into service, remove four attaching screws ①, draw out the stacker in the direction of the arrow and fix it in position. In addition, be sure to attach safety pipe ③ for the stacker as illustrated in the sketch when using it with your machine.

(4) Set-up of SA84 darts stretcher (optional)

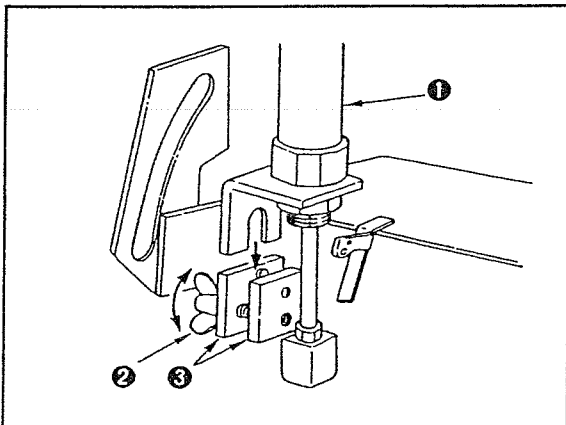

SA84 darts stretcher ① (optional) has been detached from the machine at the time of delivery. Loosen hinge screw ②, place the darts stretcher in metal fittings ③ and tighten hinge screw ②. When it is necessary to tilt the machine head, detach darts stretcher ① following the aforementioned procedure in the reverse order.

(4) Connecting the foot pedal

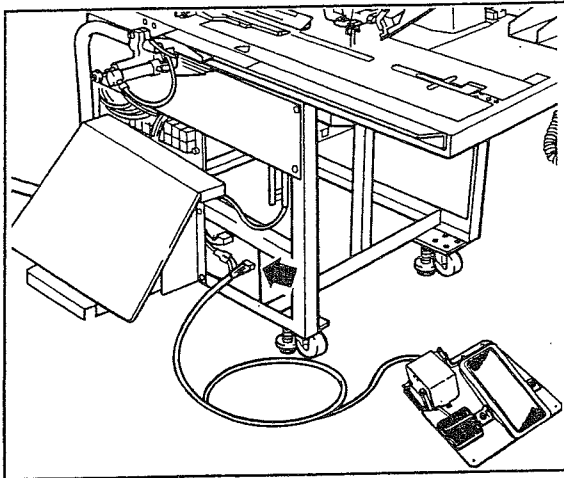

Connecting the foot pedal to the machine as illustrated in the sketch on the left.

(5) Connecting the air coupler

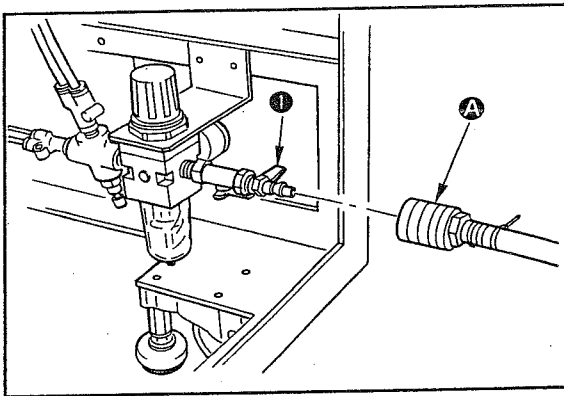

Connect one end of the air coupler **A** supplied with the machine as an accessory to the air hose. Then, connect the other end of the air coupler to the main unit.

(Caution) Connect the coupler **A** to the main unit with the air cock **B** closed, then carefully open the air cock to allow the compressed air to be supplied. Make sure that the pressure gauge of the regulator reads 0.5 MPa.

(6) Connecting the power plug



CAUTION:

To prevent possible accidents caused by leakage or dielectric strength, an appropriate power plug shall be installed by a person who has an expert knowledge of electricity. Be sure to connect the power plug to the receptacle that is well grounded.

(7) Assembling the thread stand and attaching it to the machine

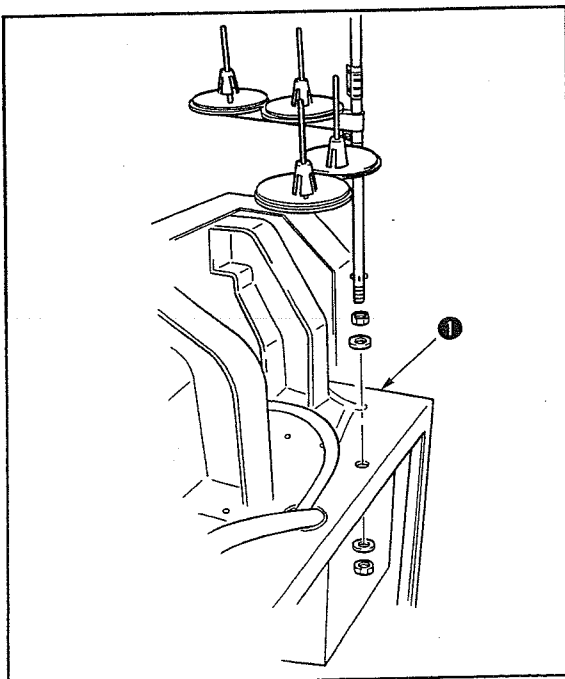

Putting two nuts and washers on the right and wrong sides of the main unit frame **1**, fix the thread stand on the frame.

IV. PREPARATION AND OPERATION

1. HOW TO OPERATE THE SEWING MACHINE HEAD



WARNING:

Turn OFF the power before starting the work so as to prevent accidents caused by abrupt start of the sewing machine.

(1) How to attach the needles

Mt × 190, #16 is a standard needle for this machine. Use the specified needle.

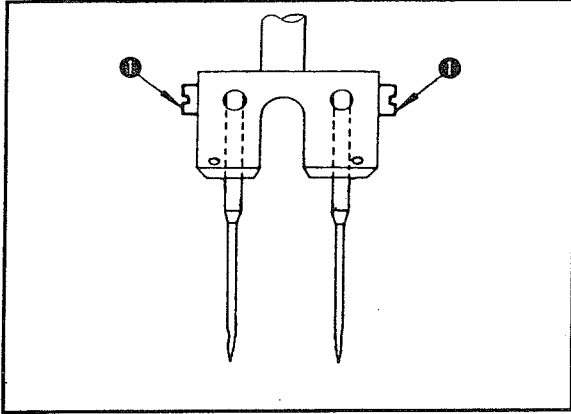

Insert the left- and right-hand sides needles as far as they will go pointing their long grooves at each other and tighten set screws ①.

(2) Types of thread

Use a new thread which is uniformly twisted.

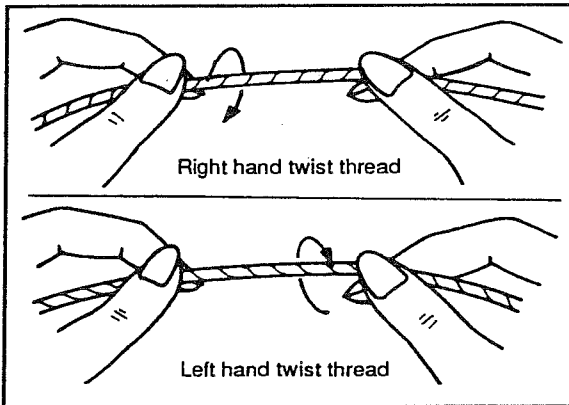

- Use the left hand twist thread for the needle.
However, either twist thread will do for the bobbin.

(3) How to thread the machine



WARNING:

Turn OFF the power before starting the work so as to prevent accidents caused by abrupt start of the sewing machine.

Thread the machine in the illustrated order.

Thread **A** ← Left-hand side needle thread toward the sewing machine

Thread **B** ← Right-hand side needle thread toward the sewing machine

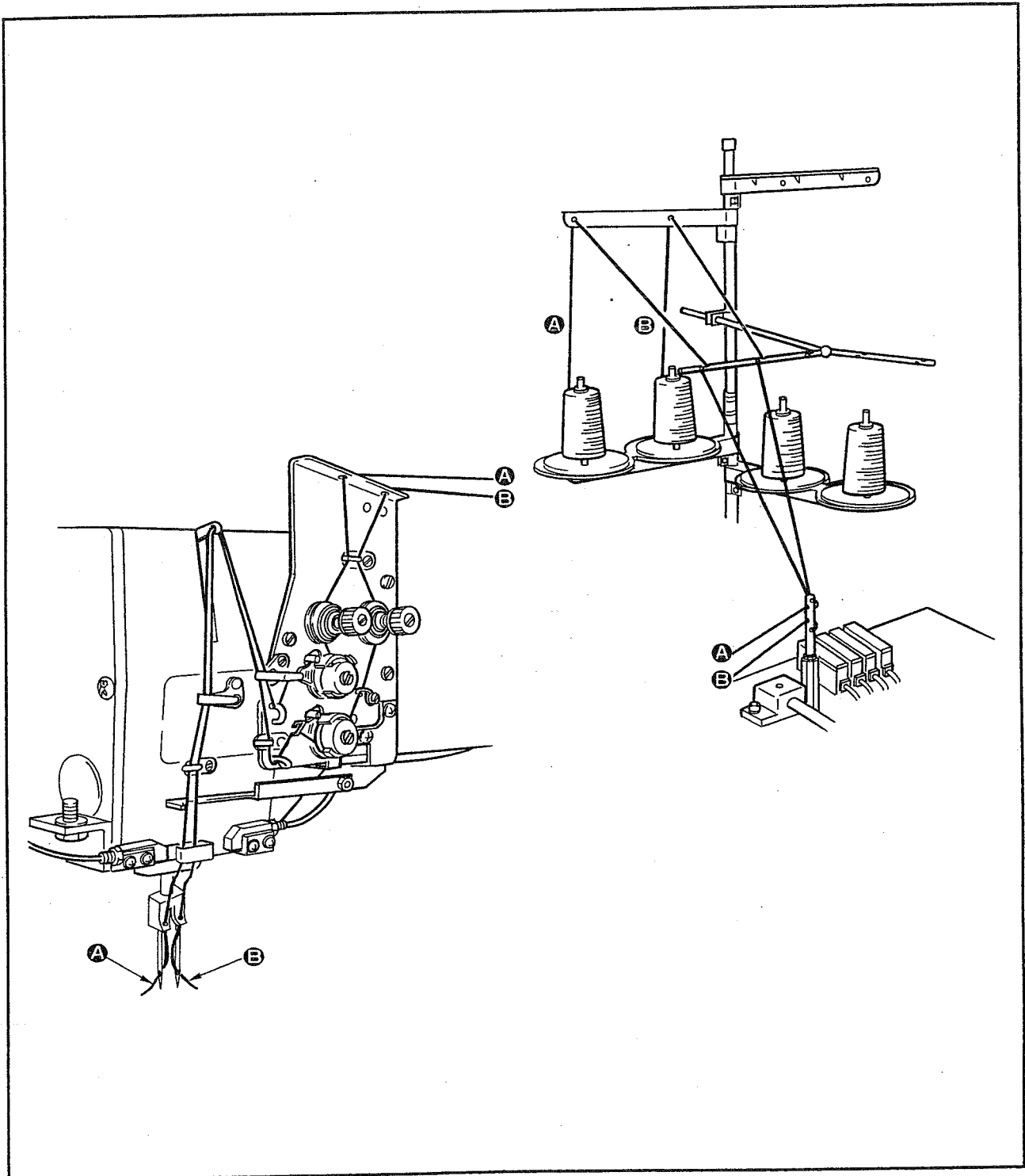

2. HOW TO REMOVE THE SEWING TABLE

(1) When changing the bobbin thread



WARNING:

Turn OFF the power before starting the work so as to prevent accidents caused by abrupt start of the sewing machine.

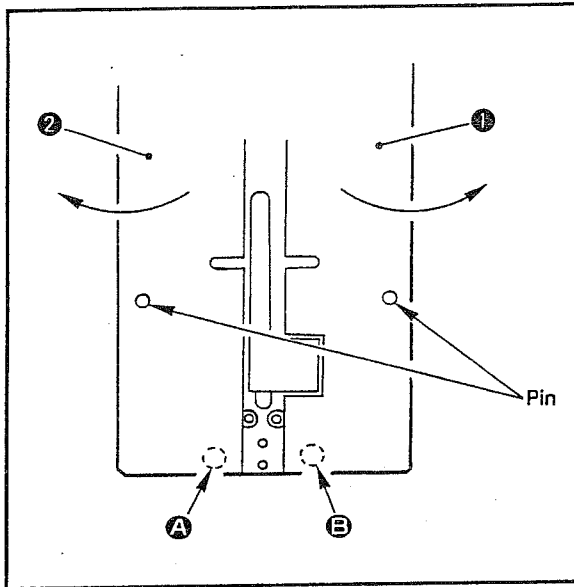

1. Move the clamp foot to the rear end of its stroke.
2. Insert your fingers into openings **A** and **B** in the bottom of right- and left-hand sewing tables **1** and **2**, and push up the sewing tables.
3. Move the tables in the direction of the arrow keeping the above state, and you can see the bobbin case.

(Caution) When you move the sewing tables, take care not to allow the sewing tables to hit against the needles.

4. After changing the bobbin thread, return the sewing tables in place by following the above-mentioned steps of procedure in the reverse order. Now firmly set the sewing tables on the throat plate and the pin.

(2) Cautions to be taken when the sewing tables are removed



WARNING:

Turn OFF the power before starting the work so as to prevent accidents caused by abrupt start of the sewing machine.

When you remove the sewing tables, be sure to set them accurately in their original positions.

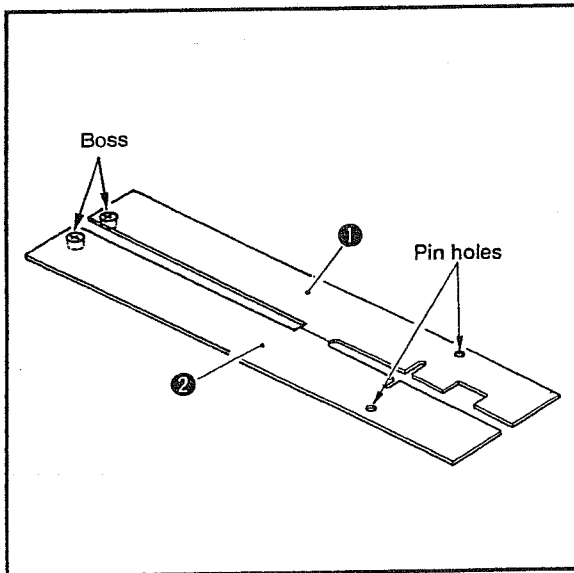

1. Securely fit the pin holes, front (left) (right) over the pins.
2. Securely fit the bosses, (left) and (right) over the boss holes in the main unit table.

3. HOW TO WIND THE BOBBINS



WARNING:

Avoid contact with bobbins while the machine is in operation.

You can wind two bobbins at a time.

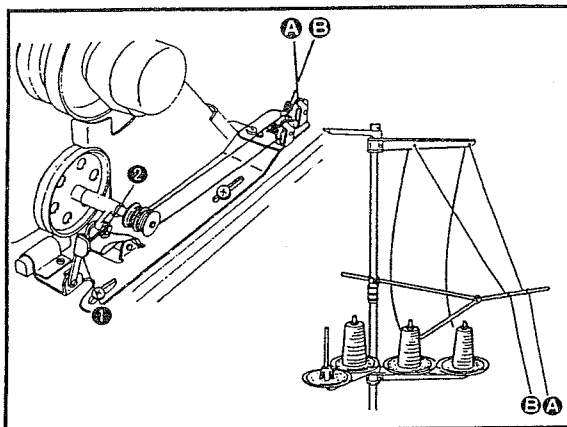

1. Put two bobbins into the thread winder shaft until they will go no further.
2. Thread the winder in the order as illustrated, and wind the thread onto each bobbin by four or five turns.
3. Press winder thread guide ①.
4. The thread winder will automatically stop as soon as it has wound up the bobbins to a predetermined amount.

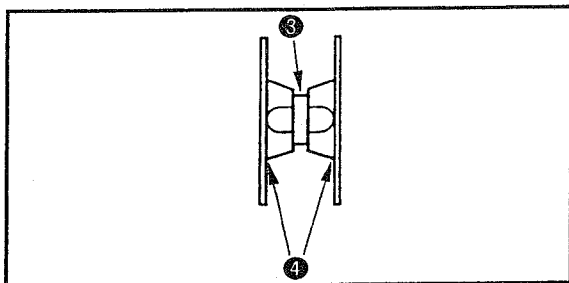

(Caution) 1. If you want to wind a bobbin, start winding it from recess ③ as illustrated in the figure on the left. If you start to wind a bobbin from portion ④, the detection of run-out of bobbin thread will fail to be performed normally.

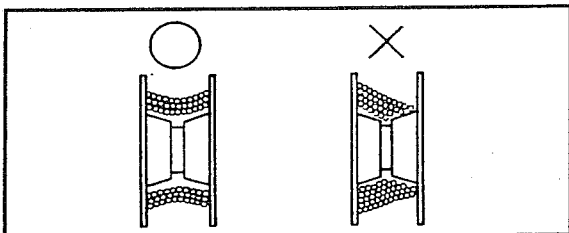

2. To ensure the appropriate remaining amount of bobbin thread, it is important to wind the bobbin uniformly. Be sure to check that the bobbin is uniformly wound particularly at the start of bobbin winding. If the bobbin fails to be uniformly wound with thread, properly adjust the bobbin winder.

4. ADJUSTING THE BOBBIN THREAD AMOUNT TO BE WOUND ROUND THE BOBBIN

It is recommendable to wind the bobbin about 80 % of its outside diameter with the cotton thread. This can be adjusted by tightening screw ② to increase or loosening it to reduce the amount of thread to be wound round the bobbin.

5. HOW TO THREAD THE BOBBIN CASE

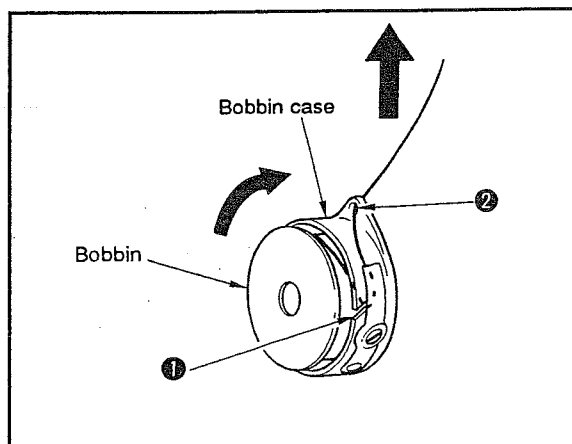

1. Hold in hand a bobbin in the way that it spins clockwise and put it into the bobbin case.
2. Pass the thread through slot ① in the bobbin case.
3. Pull the thread to pass it under the tension spring.
4. Pass it through hole ② in the bobbin case.

6. HOW TO INSTALL THE BOBBIN CASE



WARNING:

Turn OFF the power before starting the work so as to prevent accidents caused by abrupt start of the sewing machine.

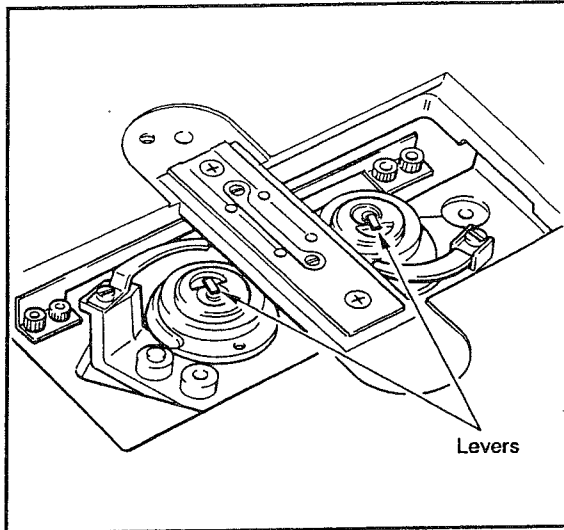

- Fit the bobbin cases into the hook driving shaft, and tilt the hook lever.

7. HOW TO ADJUST THE THREAD TENSION

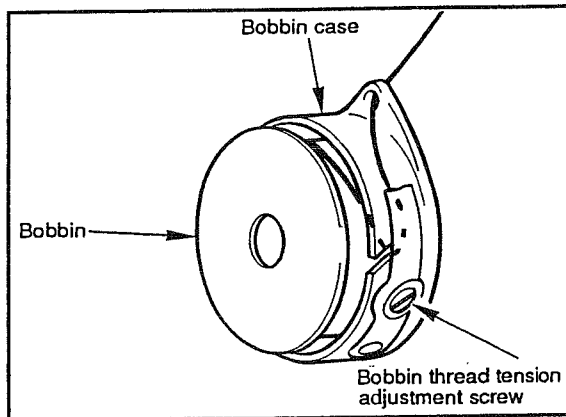

- ① Bobbin thread tension
 - Turn to screw clockwise to increase the bobbin thread tension or turn the screw counterclockwise to decrease it. Standard bobbin thread tension 0.3 to 0.35 N.

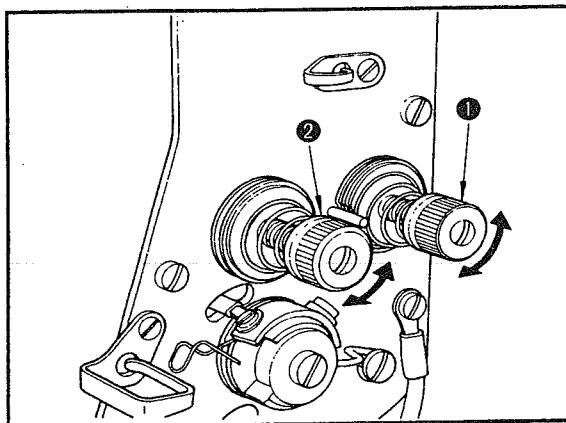

- ② Needle thread tension
 - Adjust the right- and left-hands bobbin thread tension.
 - Then in accordance with the bobbin thread tension obtained, adjust the right- and left-hand sides needle threads tension appropriately by turning thread tension adjustment nuts ① and ② respectively. Turning the nuts clockwise will increase the thread tension or turning them counterclockwise to decrease it.

8. PEDAL SWITCH



WARNING:

To protect against possible accidents due to abrupt start of the machine, keep your hands, fingers and face from moving parts of the main unit of the machine and place no tool near them.

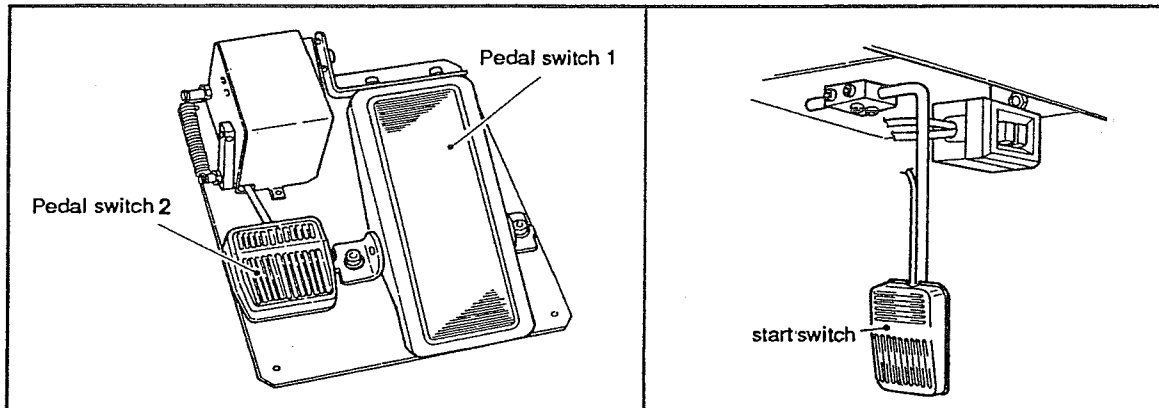

Sewing preparation from the clamp foot forwarding to the rapid feed of the material is all performed by operating this pedal 1 and the start switch. Pedal switch 2 is used to lift the interlining presser.



The clamp feet move at a high speed when the foot pedal is depressed. Do not put hands, fingers, face, etc. within the moving range of the clamp feet while placing the foot on the pedal.

[Standard specifications]

- | | |
|--------------------|---|
| 1st step | Clamp foot forward (Welt patch grasping action is taken) ^{Note 1)} ↓ (After the front end sensor is turned ON, the clamp foot moves forward as far as 5 mm, and then stops there.) Clamp foot (right) comes down Clamp foot (left) comes down |
| 2nd step | |
| 3rd step | Binder comes down ↓ (Binder comes down 0.2 sec. after the binder lowest end sensor is turned ON.) Folding plate closes (Automatic flap feeder operates) ^{Note 2)} |
| 4th step | Flap presser (right) closes. |
| 5th step | Flap presser (left) closes. |
| Start switch | Rapid feed (The machine starts sewing.) |

[When the darts stretcher is installed] (Optional device)

- | | |
|--------------------|---|
| 1st step | Darts stretcher operates |
| 2nd step | Clamp foot forward (Welt patch grasping action is taken) ^{Note 1)} ↓ (After the front end sensor is turned ON, the clamp foot moves forward as far as 5 mm, and then stops there.) Clamp foot (right) comes down Clamp foot (left) comes down |
| 3rd step | Darts stretcher returns |
| 4th step | Binder comes down ↓ (Binder comes down 0.2 sec. after the binder lowest end sensor is turned ON.) Folding plate closes (Automatic flap feeder operates) ^{Note 2)} |
| 5th step | Flap presser (right) closes |
| 6th step | Flap presser (left) closes |
| Start switch | Rapid feed (The machine starts sewing.) |

Note 1) The automatic welt patch feeder (optional) actuates when it is mounted on the machine.

Note 2) The automatic flap feeder (optional) actuates when it is mounted on the machine.

9. OPERATION PANEL SWITCHES AND INDICATOR LAMPS









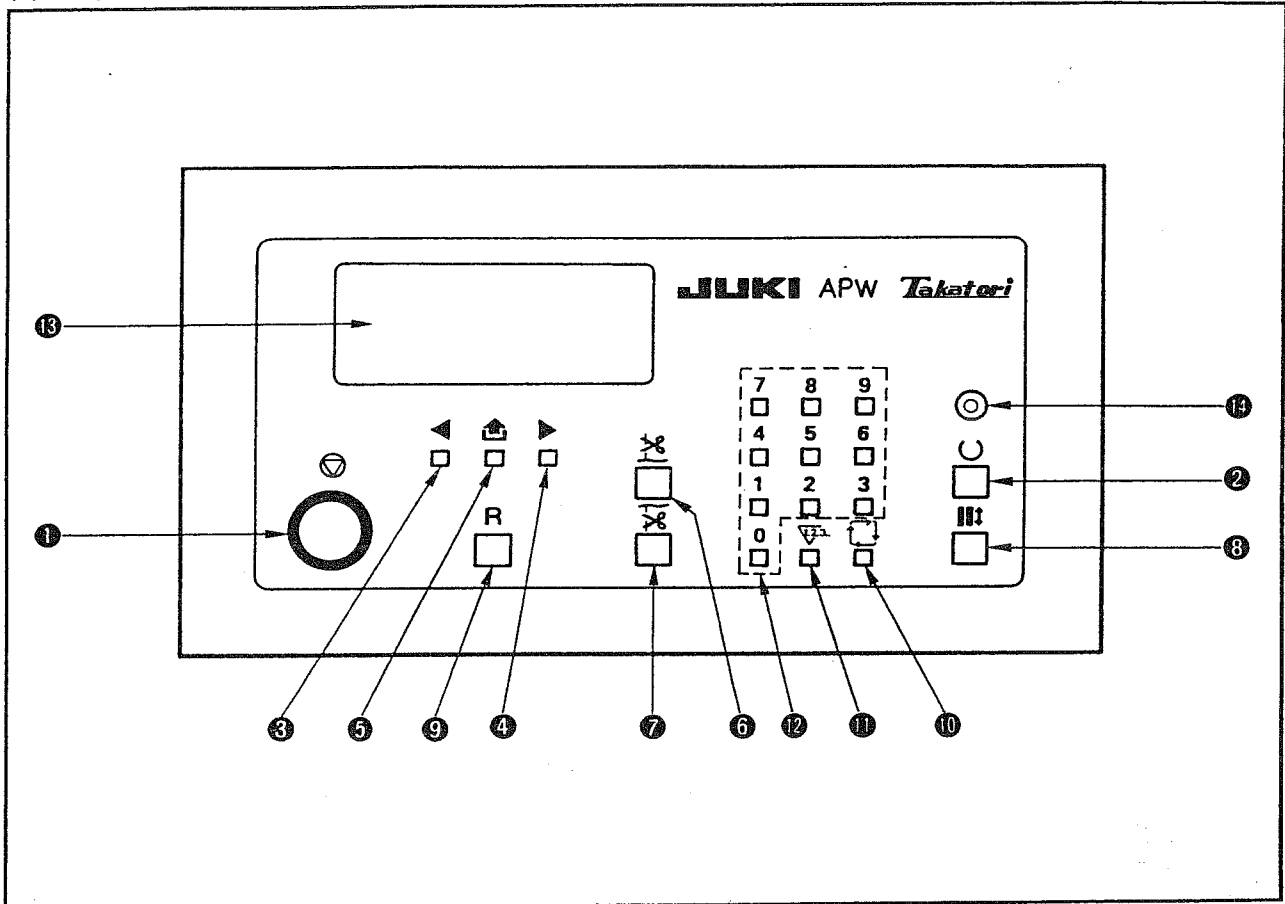

WARNING:



To protect against possible accidents due to abrupt start of the machine, firstly make sure that you have placed neither your hands, fingers, face, nor any tool in moving parts of the main unit of the machine, then operate the switches (keys).

(1) Operation panel switches



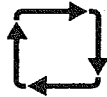

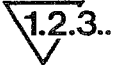
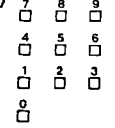

| Panel indication | Function and operation |
|---|--|
| <p>① EMERGENCY STOP switch</p>  | <p>Press this push-button switch whenever an abnormal noise is heard or you want to stop the sewing machine in an emergency.</p> <ul style="list-style-type: none"> • The machine stops with its needle up. • The clamp foot feed mechanism stops in its lowest position. • “* AL-01 *” is indicated on the LCD. <p>In the above state, the machine stops operating.</p> |
| <p>② MACHINE READY indicator lamp and key</p>  | <p>Used to change over the operation mode between the “manual mode” and the “automatic mode”. Under the manual mode, this key is used for specifying data required, trimming needle thread and bobbin thread and making the clamp foot travel forward/backward. Under the automatic mode, this key is used for starting sewing.</p> <p>The machine checks whether the sensors normally work. If any of the sensors is not normal, the machine outputs an alarm. At the same time, the machine checks the range of data required for sewing. If any of the data is out of the setting range, the machine outputs an alarm.</p> <p>Mode indicator LED ⑭ goes out under the manual mode. Mode indicator LED ⑭ lights up under the automatic mode.</p> |

| Panel indication | Function and operation |
|---|--|
| <p>③ Jog key to shift data correcting position to the left</p>  | <p>Used to shift the pictograph that is flashing on and off to the left. (If this key is kept pressed for 0.7 sec. or longer, the pictograph will automatically keep moving to the left.)</p> |
| <p>④ Jog key to shift data correcting position to the right</p>  | <p>Used to shift the pictograph that is flashing on and off to the right. (If this key is kept pressed for 0.7 sec. or longer, the pictograph will automatically keep moving to the right.)</p> |
| <p>⑤ SCREEN CHANGE-OVER key</p>  | <p>Used to change over the screen shown on the display or the setting mode. (Under the manual mode)</p> |
| <p>⑥ NEEDLE THREAD TRIMMING key</p>  | <p>The needle thread trimming descends only when this key is kept pressed. Note that the needle thread trimming knife does not actuate in the following cases.</p> <ul style="list-style-type: none"> { 1. The clamp foot is not in its rear end. { 2. The machine does not operate under the manual mode. |
| <p>⑦ BOBBIN THREAD TRIMMING key</p>  | <p>The bobbin thread is released only when this key is kept pressed. Note that the bobbin thread is not released in the following cases.</p> <ul style="list-style-type: none"> { 1. The clamp foot is not in its rear end. { 2. The machine does not operate under the manual mode. |
| <p>⑧ CLAMP FOOT TRAVEL key</p>  | <p>Each time you press this key, the clamp foot alternately repeats forward travel and backward travel. Note that the clamp foot travels only when the sewing machine operates under the manual mode.</p> <ul style="list-style-type: none"> { When the clamp foot is in its rear end: → It travels to its front end. { When the clamp foot is not in its rear end: → It travels to its rear end. |
| <p>⑨ RESET key</p>  | <p>Used in the following cases.</p> <ol style="list-style-type: none"> 1. To release the machine from the alarm state. (When the alarm screen is shown on the display.) 2. To change the order of cycle sewing operation steps. (When the cycle sewing screen is shown on the display.) 3. To reset the NUMBER OF PIECES COUNTER. (When the counter screen is shown on the display.) (When the count-up screen is shown on the display.) 4. To reset the TOTAL COUNTER. (When the counter screen is shown on the display.) 5. To finish the check program. (When the check screen is shown on the display.) |
| <p>⑩ CYCLE key</p>  | <p>Used to show the cycle screen on the display. (Under the manual mode) (If pressing the "0" key from the ten keys with the CYCLE key kept pressed, the maintenance screen is shown on the display screen.)</p> |

| Panel indication | Function and operation |
|--|---|
| <p>⑪ COUNTER key</p>  | <p>Used to call the counter screen on the display. (Under the manual mode)</p> |
| <p>⑫ Ten keys (numeric keys)</p>  | <p>Used to specify data.</p> |
| <p>⑬ LCD display unit</p> | <p>Indicates specified data, state of the machine and function used.</p> |
| <p>⑭ Mode indicator LED</p>  | <p>Used to indicate either *1 the “manual mode” or *2 the “automatic mode”. The LED goes out under the manual mode, or lights up under the automatic mode.</p> <p>*1 Manual mode When turning ON the power to the machine, or when resetting the alarm state, the sewing machine is set to the manual mode. At this time, mode indicator LED ⑭ goes out. LCD display unit ⑬ is equipped with the four different pictographs 1 through 4. One of these pictographs always lights up. At this time, data can be set or modified.</p> <p>*2 Automatic mode MACHINE READY key ② is used to change over the operation mode between the manual mode and the automatic mode. Mode indicator LED ⑭ lights up under the automatic mode. The sewing pattern used is indicated on the leftmost section of LCD display unit ⑬, and the data on the current state of the sewing machine including the number of pieces of garment finished are shown on the right section of the display. No indication on the LCD display unit flashes on and off. Sewing is possible under this mode.</p> |

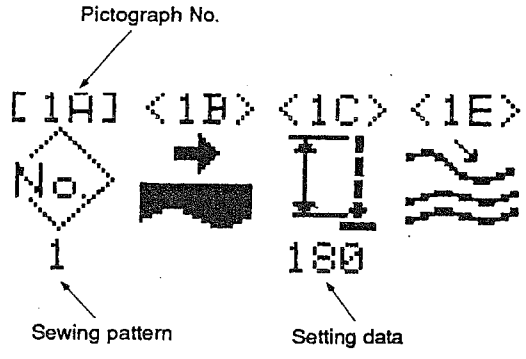
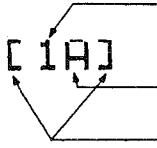
(2) Manual mode and automatic mode

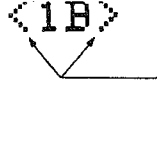
| Panel indication | Function and operation |
|---|---|
| <p>① Operating procedure of the LCD (Under the manual mode)</p> | <p>1. Cycle screen</p> <div data-bbox="520 283 1040 682" style="text-align: center;"> </div> <p>(The LCD shows the cycle sewing consisting of the L size sewing (150 mm) left-flap sewing and right-flap sewing.)</p> <p style="text-align: center;">Cycle screen 1</p> <ul style="list-style-type: none"> • The screen shown above is given on the display when turning ON the power to the machine or when changing over the operation mode from the automatic mode to the manual mode. • Pressing the RESET key R shifts the order of cycle sewing steps. This function is used to sew the pattern which has been sewn again in the cycle sewing. • Pressing the SCREEN CHANGE-OVER key make the LCD indicate the sewing pattern whose number is shown by the flashing pictograph. • Press the CYCLE key makes the LCD show the screen next to any current screen. (Excluding the cases where the sewing machine operates under the automatic mode, an alarm occurs, the bobbin thread is counted up and the sewing machine operates under the independent operation mode.) <div data-bbox="553 1113 925 1428" style="text-align: center;"> </div> <p style="text-align: center;">Cycle screen 2</p> <p>* Mark indicating that the cycle edition is possible.</p> <p>When the mark telling that "cycle edition is possible" (the asterisk mark (*) in the figure above), the cycle sewing patterns can be changed.</p> <ul style="list-style-type: none"> • Cycle sewing patterns can be changed by inputting another sewing pattern number you wish to sew with the relevant numeric key (0 through 9). • If you have made any mistake when editing data on cycle sewing, press the CYCLE key , then input the numbers of the correct sewing patterns with the numeric keys from the very start. • As many as five cycles can be specified. |

| Panel indication | Function and operation |
|------------------|---|
| | <p>2. Sewing pattern screen</p> <ul style="list-style-type: none"> The sewing pattern screen can be shown on the display by pressing the SCREEN CHANGE-OVER key  when the cycle screen is indicated on the display. Ten different sewing patterns (0 through 9) are prepared. All the data required for sewing are specified on the sewing pattern screen. <div style="text-align: center;">  </div> <p style="text-align: center;">Example of the sewing pattern screen 1</p> <ul style="list-style-type: none"> Four different pictographs are shown on the single screen. The pictograph numbers are shown above the respective pictographs. <div style="display: flex; justify-content: space-between; align-items: flex-start; margin-top: 20px;"> <div style="width: 45%;"> <p>Pictograph No.</p>  </div> <div style="width: 50%;"> <p>This number indicates the sewing pattern number. (0 through 9)</p> <p>This alphabet indicates the pictograph number. (A through U)</p> <p>The angle brackets [] do not change even if pressing the SCREEN CHANGE-OVER key .</p> </div> </div> <div style="display: flex; justify-content: space-between; align-items: flex-start; margin-top: 20px;"> <div style="width: 45%;"> <p>Pictograph No.</p>  </div> <div style="width: 50%;"> <p>The brackets < > change by pressing the SCREEN CHANGE-OVER key .</p> </div> </div> |

Panel indication

Function and operation

| | | | | | | | | | | | | | | | | | | | | | | | | | | | | | | | | | | | | | | | | | | | | | | | | | | | | | | | | | | | | | | | | | | | | | | | | | | | | | | | | | | | | | | | | | | | | | | | | | | | | | | | | | | | | | | | | | | | | | | | | | | | | | | | | | | | | | | | | | | | | | | | | | | | | | | | | | | | | | | | | | | | | | | | | | | | | | | | | | | | | | | | | | | | | | | | | | | | | | | | | | | | | | | | | | | | | | | | | | | | | | | | | | | | | | | | | | | | | | | | | | | | | | | | | | | | | | | | | | | | | | | | | | | | | | | | | | | | | | | | | | | | | | | | | | | | | | | | | | | | | | | | | | | | | | | | | | | | | | | | | | | | | | | | | | | | | | | | | | | | | | | | | | | | | | | | | | | | | | | | | | | | | | | | | | | | | | | | | | | | | | | | | | | | | | | | | | | | | | | | | | | | | | | | | | | | | | | | | | | | | | | | | | | | | | | | | | | | | | | | | | | | | | | | | | | | | | | | | | | | | | | | | | | | | | | | | | | | | | | | | | | | | | | | | | | | | | | | | | | | | | | | | | | | | | | | | | | | | | | | | | | | | | | | | | | | | | | | | | | | | | | | | | | | | | | | | | | | | | | | | | | | | | | | | | | | | | | | | | | | | | | | | | | | | | | | | | | | | | | | | | | | | | | | | | | | | | | | | | | | | | | | | | | | | | | | | | | | | | | | | | | | | | | | | | | | | | | | | | | | | | | | | | | | | | | | | | | | | | | | | | | | | | | | | | | | | | | | | | |
|--|--|--|--|--|--|--|--|--|--|--|--|--|--|--|--|--|--|--|--|--|--|--|--|--|--|--|--|--|--|--|--|--|--|--|--|--|--|--|--|--|--|--|--|--|--|--|--|--|--|--|--|--|--|--|--|--|--|--|--|--|--|--|--|--|--|--|--|--|--|--|--|--|--|--|--|--|--|--|--|--|--|--|--|--|--|--|--|--|--|--|--|--|--|--|--|--|--|--|--|--|--|--|--|--|--|--|--|--|--|--|--|--|--|--|--|--|--|--|--|--|--|--|--|--|--|--|--|--|--|--|--|--|--|--|--|--|--|--|--|--|--|--|--|--|--|--|--|--|--|--|--|--|--|--|--|--|--|--|--|--|--|--|--|--|--|--|--|--|--|--|--|--|--|--|--|--|--|--|--|--|--|--|--|--|--|--|--|--|--|--|--|--|--|--|--|--|--|--|--|--|--|--|--|--|--|--|--|--|--|--|--|--|--|--|--|--|--|--|--|--|--|--|--|--|--|--|--|--|--|--|--|--|--|--|--|--|--|--|--|--|--|--|--|--|--|--|--|--|--|--|--|--|--|--|--|--|--|--|--|--|--|--|--|--|--|--|--|--|--|--|--|--|--|--|--|--|--|--|--|--|--|--|--|--|--|--|--|--|--|--|--|--|--|--|--|--|--|--|--|--|--|--|--|--|--|--|--|--|--|--|--|--|--|--|--|--|--|--|--|--|--|--|--|--|--|--|--|--|--|--|--|--|--|--|--|--|--|--|--|--|--|--|--|--|--|--|--|--|--|--|--|--|--|--|--|--|--|--|--|--|--|--|--|--|--|--|--|--|--|--|--|--|--|--|--|--|--|--|--|--|--|--|--|--|--|--|--|--|--|--|--|--|--|--|--|--|--|--|--|--|--|--|--|--|--|--|--|--|--|--|--|--|--|--|--|--|--|--|--|--|--|--|--|--|--|--|--|--|--|--|--|--|--|--|--|--|--|--|--|--|--|--|--|--|--|--|--|--|--|--|--|--|--|--|--|--|--|--|--|--|--|--|--|--|--|--|--|--|--|--|--|--|--|--|--|--|--|--|--|--|--|--|--|--|--|--|--|--|--|--|--|--|--|--|--|--|--|--|--|--|--|--|--|--|--|--|--|--|--|--|--|--|--|--|--|--|--|--|--|--|--|--|--|--|--|--|--|--|--|--|--|--|--|--|--|--|--|--|--|--|--|--|--|--|--|--|--|--|--|--|--|--|--|--|--|--|--|--|--|--|--|--|--|--|--|--|--|--|--|--|--|--|--|--|--|--|--|--|--|--|--|--|--|--|--|--|--|--|--|--|--|--|--|--|--|--|--|--|--|--|--|--|--|--|--|--|--|--|--|--|--|--|--|--|--|--|--|--|--|--|--|--|--|--|--|--|--|--|--|--|--|--|--|--|--|--|--|--|--|--|--|--|--|--|--|--|--|--|--|--|--|--|--|--|--|--|--|--|--|--|--|--|--|--|--|--|--|--|--|--|--|--|--|--|--|--|--|--|--|--|--|--|--|--|--|--|--|--|--|--|--|--|--|--|--|--|--|
| | | | | | | | | | | | | | | | | | | | | | | | | | | | | | | | | | | | | | | | | | | | | | | | | | | | | | | | | | | | | | | | | | | | | | | | | | | | | | | | | | | | | | | | | | | | | | | | | | | | | | | | | | | | | | | | | | | | | | | | | | | | | | | | | | | | | | | | | | | | | | | | | | | | | | | | | | | | | | | | | | | | | | | | | | | | | | | | | | | | | | | | | | | | | | | | | | | | | | | | | | | | | | | | | | | | | | | | | | | | | | | | | | | | | | | | | | | | | | | | | | | | | | | | | | | | | | | | | | | | | | | | | | | | | | | | | | | | | | | | | | | | | | | | | | | | | | | | | | | | | | | | | | | | | | | | | | | | | | | | | | | | | | | | | | | | | | | | | | | | | | | | | | | | | | | | | | | | | | | | | | | | | | | | | | | | | | | | | | | | | | | | | | | | | | | | | | | | | | | | | | | | | | | | | | | | | | | | | | | | | | | | | | | | | | | | | | | | | | | | | | | | | | | | | | | | | | | | | | | | | | | | | | | | | | | | | | | | | | | | | | | | | | | | | | | | | | | | | | | | | | | | | | | | | | | | | | | | | | | | | | | | | | | | | | | | | | | | | | | | | | | | | | | | | | | | | | | | | | | | | | | | | | | | | | | | | | | | | | | | | | | | | | | | | | | | | | | | | | | | | | | | | | | | | | | | | | | | | | | | | | | | | | | | | | | | | | | | | | | | | | | | | | | | | | | | | | | | | | | | | | | | | | | | | | | | | | | | | | | | | | | | | | | | | | | | | | | | | | |
|--|--|--|--|--|--|--|--|--|--|--|--|--|--|--|--|--|--|--|--|--|--|--|--|--|--|--|--|--|--|--|--|--|--|--|--|--|--|--|--|--|--|--|--|--|--|--|--|--|--|--|--|--|--|--|--|--|--|--|--|--|--|--|--|--|--|--|--|--|--|--|--|--|--|--|--|--|--|--|--|--|--|--|--|--|--|--|--|--|--|--|--|--|--|--|--|--|--|--|--|--|--|--|--|--|--|--|--|--|--|--|--|--|--|--|--|--|--|--|--|--|--|--|--|--|--|--|--|--|--|--|--|--|--|--|--|--|--|--|--|--|--|--|--|--|--|--|--|--|--|--|--|--|--|--|--|--|--|--|--|--|--|--|--|--|--|--|--|--|--|--|--|--|--|--|--|--|--|--|--|--|--|--|--|--|--|--|--|--|--|--|--|--|--|--|--|--|--|--|--|--|--|--|--|--|--|--|--|--|--|--|--|--|--|--|--|--|--|--|--|--|--|--|--|--|--|--|--|--|--|--|--|--|--|--|--|--|--|--|--|--|--|--|--|--|--|--|--|--|--|--|--|--|--|--|--|--|--|--|--|--|--|--|--|--|--|--|--|--|--|--|--|--|--|--|--|--|--|--|--|--|--|--|--|--|--|--|--|--|--|--|--|--|--|--|--|--|--|--|--|--|--|--|--|--|--|--|--|--|--|--|--|--|--|--|--|--|--|--|--|--|--|--|--|--|--|--|--|--|--|--|--|--|--|--|--|--|--|--|--|--|--|--|--|--|--|--|--|--|--|--|--|--|--|--|--|--|--|--|--|--|--|--|--|--|--|--|--|--|--|--|--|--|--|--|--|--|--|--|--|--|--|--|--|--|--|--|--|--|--|--|--|--|--|--|--|--|--|--|--|--|--|--|--|--|--|--|--|--|--|--|--|--|--|--|--|--|--|--|--|--|--|--|--|--|--|--|--|--|--|--|--|--|--|--|--|--|--|--|--|--|--|--|--|--|--|--|--|--|--|--|--|--|--|--|--|--|--|--|--|--|--|--|--|--|--|--|--|--|--|--|--|--|--|--|--|--|--|--|--|--|--|--|--|--|--|--|--|--|--|--|--|--|--|--|--|--|--|--|--|--|--|--|--|--|--|--|--|--|--|--|--|--|--|--|--|--|--|--|--|--|--|--|--|--|--|--|--|--|--|--|--|--|--|--|--|--|--|--|--|--|--|--|--|--|--|--|--|--|--|--|--|--|--|--|--|--|--|--|--|--|--|--|--|--|--|--|--|--|--|--|--|--|--|--|--|--|--|--|--|--|--|--|--|--|--|--|--|--|--|--|--|--|--|--|--|--|--|--|--|--|--|--|--|--|--|--|--|--|--|--|--|--|--|--|--|--|--|--|--|--|--|--|--|--|--|--|--|--|--|--|--|--|--|--|--|--|--|--|--|--|--|--|--|--|--|--|--|--|--|--|--|--|--|--|--|--|--|--|--|--|--|--|--|--|--|--|--|--|--|--|--|--|--|--|--|--|--|--|--|--|--|--|--|--|--|--|--|--|--|--|--|--|--|--|--|--|--|







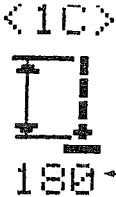
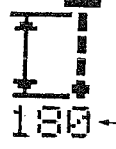

Pattern No.

(Pictographs marked by arrows (↑ • ↓) can be changed over using the SCREEN CHANGE-OVER key .)

(Specified data are the standard values. [Only the L size sewing uses the maximum value.]



: Sewing pattern number (0 through

| Panel indication | Function and operation |
|------------------|---|
| | <p>  : L size sewing using the rear reference (The sewing end position is 240 mm away from the needle bar.) The L size sewing length is specified using the ten keys. (Unit: mm) 180 ← L size data specified *(35 mm to 180 mm) </p> <p>(Note 1)</p> <p>  : L size sewing using the front reference (The sewing start position is 60 mm away from the needle bar.) The L size sewing length is specified using the ten keys. (Unit: mm) 180 ← L size data specified *(35 mm to 180 mm) </p> <p>(Note 1)</p> <p>  : L size sewing using the center reference (The center of sewing length is 150 mm away from the needle bar.) The L size sewing length is specified using the ten-keys. (Caution) The cross marking lamp for the center reference is optionally available. 180 ← L size data specified *(35mm to 180 mm) </p> <p>  : Right-flap sewing </p> <p>  : Left-flap sewing </p> <p>  : Flap sewing priority mode Either left or right sensor which detects a flap first will be effective. </p> |
| | <p>(Note 2) <1d></p> <p>  : Automatic flap supplying device actuates. </p> <p>  : Automatic flap supplying device stops. </p> |
| | <p><1E></p> <p>  : Stacker operation mode is specified. </p> <p>  : Stacker no-operation mode is specified. </p> |

(Note 1) : This indication is shown on the display when an automatic welting patch supplying device (optional) is mounted on the machine.
 (Note 2) : This indication is shown on the display when an automatic flap supplying device (optional) is mounted on the machine.

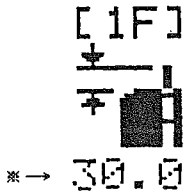
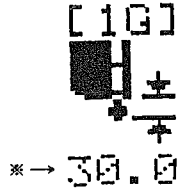
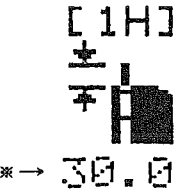
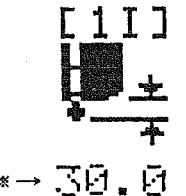
| Panel indication | Function and operation |
|------------------|--|
| | <p>(Note 1)</p>  <p>: Left-flap concealed stitching data at the sewing start (Data setting range 0.0 to 99.9 mm Note that the specified value should exceed the difference at the sewing start.)</p> |
| | <p>(Note 1)</p>  <p>: Left-flap concealed stitching data at the sewing end (Data setting range 0.0 to 99.9 mm Note that the specified value should exceed the difference at the sewing end.)</p> |
| | <p>(Note 2)</p>  <p>: Right-flap concealed stitching data at the sewing start (Data setting range 0.0 to 99.9 mm Note that the specified value should exceed the difference at the sewing start.)</p> |
| | <p>(Note 2)</p>  <p>: Right-flap concealed stitching data at the sewing end (Data setting range 0.0 to 99.9 mm Note that the specified value should exceed the difference at the sewing end.)</p> |

* Specified data (Input with the ten keys.)

(Note 1) : This indication is not shown on the display when the pictograph No. $\langle 1C \rangle$ is set to the left-flap sewing or flap sewing precedence mode.

(Note 2) : This indication is not shown on the display when the pictograph No. $\langle 1C \rangle$ is set to the right-flap sewing or flap sewing precedence mode.

1. Increase the data setting value when the length of concealed sewing at the start of sewing is longer than that of at the sewing end.

(Example)

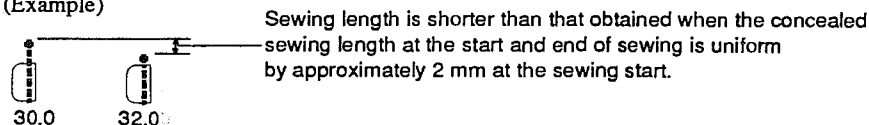

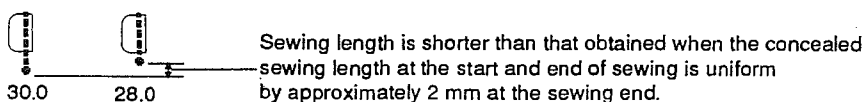

2. Decrease the data setting value when the length of concealed sewing at the start of sewing is shorter than that of at the sewing end.
3. Decrease the data setting value when the length of concealed sewing at the end of sewing is longer than that of at the sewing start.

(Example)

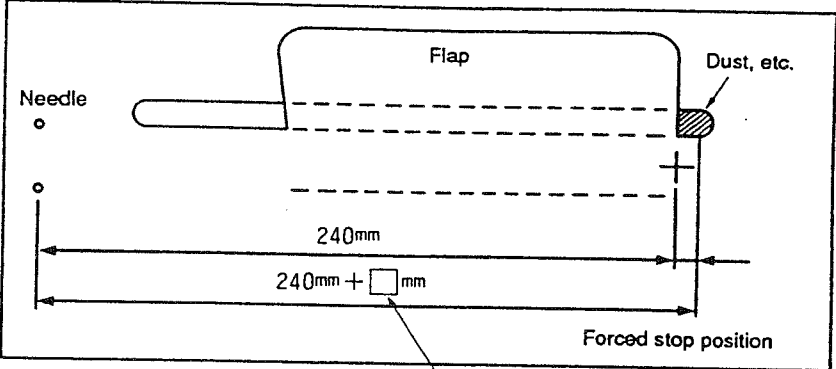

4. Increase the data setting value when the length of concealed sewing at the end of sewing is shorter than that of at the sewing start.

| Panel Indication | Function and operation |
|------------------|--|
| | <p>(Note)</p>  <p>※ →  : Flap forced stop (Data setting range: 0 to 10 mm)</p> <p>This is the switch for setting a position at which the machine forcibly stops flap sewing after the origin to prevent the center knife from cutting the sewing product when the rear end of the flap is not detected by the sensor because of dust, etc. in the flap sewing. The switch can be specified within the range of 0 to 10 mm. The forced stop position is set to a position that is away from the origin (240 mm away from the needle) by the specified distance.</p> <p>(Caution) If the sewing position does not change after having changed the setting of flap concealed stitching, suppose that the flap forced stop function works preferentially. So, check the value specified for flap forced stop position.</p> <p>① When the flap forced stop mechanism works, the corner knife does not actuate. (Even when the corner knife actuation has been specified.) In this case, the LCD display unit gives the indication telling that the flap forced stop mechanism has worked.</p> <div data-bbox="579 1306 839 1381" style="border: 1px solid black; padding: 2px; display: inline-block;"> FLAP SENSOR STOP </div> <p style="margin-left: 40px;">Indication on the LCD</p> <p>② The flap forced stop indication is reset by pressing the MACHINE READY key  or depressing the foot pedal.</p> |

* Specified data (Input with the ten keys.)

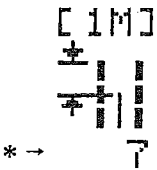
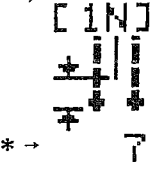
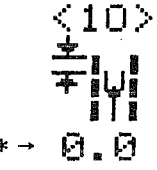
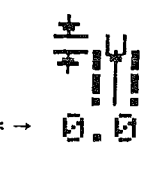
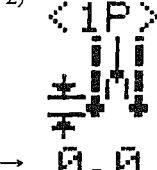
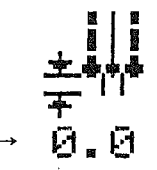

(Note) : This indication is not shown on the display when the pictograph No.  is set to the L size sewing.

| Panel indication | Function and operation |
|------------------|--|
| | <p>(Note 1)</p>  <p>: Center knife actuating position at the sewing start (Data setting range 5 to 15 mm)</p> |
| | <p>(Note 1)</p>  <p>: Center knife actuating position at the sewing end (Data setting range 7 to 15 mm)</p> |
| | <p>(Note 2)</p>  <p>: Corner knife actuating position at the sewing start (Data setting range 0.0 to 10.0 mm)</p> <p>* → 0.0</p>  <p>: Corner knife actuating position at the sewing start (Data setting range 0.0 to 10.0 mm)</p> <p>* → 0.0</p> |
| | <p>(Note 2)</p>  <p>: Corner knife actuating position at the sewing end (Data setting range 0.0 to 10.0 mm)</p> <p>* → 0.0</p>  <p>: Corner knife actuating position at the sewing end (Data setting range 0.0 to 10.0 mm)</p> <p>* → 0.0</p> |

* Specified data (Input with the ten keys.)

(Note 1) : This indication is shown on the display when the pictograph No. <1B> is set to the mode in which the center knife is used.

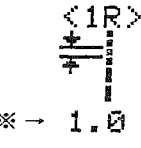
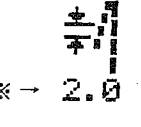
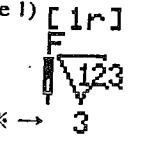
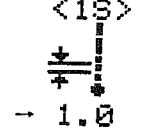
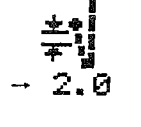
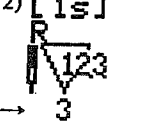
(Note 2) : This indication is shown on the display when the pictograph No. <1B> is set to the mode in which the corner knife is used.

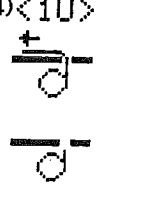
| Panel indication | Function and operation |
|---|--|
|  | <p>: Lockstitch pitch (Data setting range 2.0 to 3.4 mm)</p> |
|  | <p>: Sewing start side condensation stitching and condensation pitch are specified. (Data setting range 0.5 to 1.5 mm)</p> |
|  | <p>: Sewing start side back tack stitching and back tack pitch are specified. (Data setting range 0.5 to 3.4 mm Note that the back tack pitch should not exceed the lockstitch pitch.)</p> |
| <p>(Note 1)</p>  | <p>: Sewing start side number of stitches of back tack is specified. (Data setting range 3 to 19) (Caution) Set the data within the range where it does not interfere with the recess of the welt patch base plate.</p> |
|  | <p>: Sewing end side condensation stitching and condensation pitch are specified. (Data setting range 0.5 to 1.5 mm)</p> |
|  | <p>: Sewing end side back tack stitching and back tack pitch are specified. (Data setting range 0.5 to 3.4 mm Note that the back tack pitch should not exceed the lockstitch pitch.)</p> |
| <p>(Note 2)</p>  | <p>: Sewing end side number of stitches of back tack is specified. (Data setting range 3 to 19) (Caution) Set the data within the range where it does not interfere with the recess of the welt patch base plate.</p> |
| <p>(Note 3)</p>  | <p>: Dart stretcher is set to operative. : Dart stretcher is set to inoperative.</p> |
| <p>(Note 4)</p>  | <p>: Automatic interlining supplying device is set to operative. : Automatic interlining supplying device is set to inoperative.</p> |



※ Specified data (Input with the ten keys.)

(Note 1) : This indication is shown when sewing start side back tack stitching is specified.

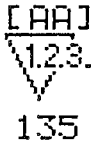
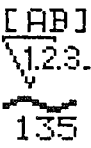

(Note 2) : This indication is shown when sewing end side back tack stitching is specified.

(Note 3) : This indication is shown on the display when the <BE> dart stretcher is set to the ON state on the adjustment screen.



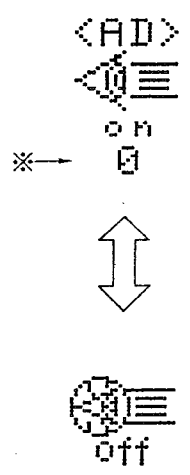

(Note 4) : This indication is shown on the display when an automatic interlining supplying device (optional) is mounted on the machine.

| Panel indication | Function and operation | | | | | | | | | | | | |
|---|---|--------|------|------|------|--------|--------|--------|---|-----|-----|---|---|
| | <p>3. Counter screen</p> <div data-bbox="768 220 1181 462" style="border: 1px solid black; padding: 5px; margin: 10px auto; width: fit-content;"> <p style="text-align: center;">Pictograph No.</p> <table style="width: 100%; border-collapse: collapse;"> <tr> <td style="text-align: center; border: 1px solid black; padding: 2px;">[AA]</td> <td style="text-align: center; border: 1px solid black; padding: 2px;">[AB]</td> <td style="text-align: center; border: 1px solid black; padding: 2px;">[AC]</td> <td style="text-align: center; border: 1px solid black; padding: 2px;"><AD></td> </tr> <tr> <td style="text-align: center;">1.2.3.</td> <td style="text-align: center;">1.2.3.</td> <td style="text-align: center;">1.2.3.</td> <td style="text-align: center;">0</td> </tr> <tr> <td style="text-align: center;">135</td> <td style="text-align: center;">135</td> <td style="text-align: center;">0</td> <td style="text-align: center;">0</td> </tr> </table> <p style="font-size: small;">Indication of the number of pieces Indication of set value</p> </div> <p>1) Press the  (counter) key regardless of the screen that appears on the display, and the screen will be changed over to the above one.</p> <p>(Caution) The screen cannot be changed over when the machine runs under the "automatic mode," when an alarm has arisen, the bobbin thread counter has reached the specified value and the machine runs independently.</p> <p>2) Explanation of the operation of pictographs is given on the followings.</p> | [AA] | [AB] | [AC] | <AD> | 1.2.3. | 1.2.3. | 1.2.3. | 0 | 135 | 135 | 0 | 0 |
| [AA] | [AB] | [AC] | <AD> | | | | | | | | | | |
| 1.2.3. | 1.2.3. | 1.2.3. | 0 | | | | | | | | | | |
| 135 | 135 | 0 | 0 | | | | | | | | | | |
|  | <p>1) Detailed explanation of the pictographs on the counter screen</p> <p>: Total counter</p> <p>Indicates the total number of pieces of finished products. To clear the number given on the counter, press the R (reset) key. (A number cannot be input using numeric keys.)</p> | | | | | | | | | | | | |
|  | <p>: No. of pcs. counter</p> <p>Indicates the number of pieces of finished products. To clear the number given on the counter, press the R (reset) key. (A number cannot be input using numeric keys.) Every time one piece of product is finished, one is added to the number shown on the counter.</p> <p>When the number appearing on the counter reaches the value specified for the bobbin thread counter, the No. of pcs. counter enters the "count-up" state. In this case, the clamp foot travels to the backward travel end and the "count-up screen" will be shown on the LCD display. At this time, the machine will no longer be able to continue sewing. Pressing the R (reset) key will reset the "count-up" state.</p> | | | | | | | | | | | | |
|  | <p>: Bobbin thread counter</p> <p>Specifies the intended number of pieces of products to be sewn. When the counter is set to "0 (zero)," the "count-up" state due to the bobbin thread counter will not take place.</p> | | | | | | | | | | | | |



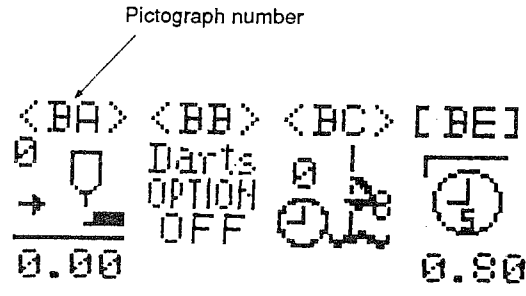



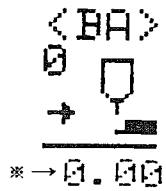

* Specified data (Input with the ten keys.)

| Panel indication | Function and operation | | | | | | | | | | | | | | | |
|---|---|--|---------------|--|-----|---|-----------|-----|---|-----------|-----|---|-----------|-----|---|-----------|
|  | <p>: Setting of the actuation of the bobbin thread remaining amount detecting device and the bobbin thread remaining amount adjusting counter</p> <p>Actuates the bobbin thread remaining amount detecting device. Sets a value for the bobbin thread remaining amount adjusting counter.</p> <ul style="list-style-type: none"> The bobbin thread remaining amount adjusting counter It is possible to retard the timing at which the machine gives the indication showing that the bobbin thread runs out by the value specified on the counter even when the sensor detects run-out of bobbin thread. This means that the remaining amount of bobbin thread can be adjusted by adjusting the counter value. To increase the bobbin thread remaining amount: → Decrease the counter value (toward 0). To decrease the bobbin thread remaining amount: → Increase the counter value (toward 9) <p>Stops the detecting of the bobbin thread remaining amount. (Caution) To change the pictograph, operate the  (screen change-over) key.</p> | | | | | | | | | | | | | | | |
| | <p>4. Setting the bobbin thread remaining amount adjusting counter</p> <ol style="list-style-type: none"> Set the bobbin thread remaining amount adjusting counter to the value shown in the table below. Start the sewing machine to perform regular sewing. In case of test sewing, adjust the sewing length to that to be sewn in the actual process. As you continue sewing, the bobbin thread is gradually reduced until the bobbin thread sensor detects run-out of bobbin thread. Now, the display gives the indication showing that the bobbin thread runs out. Check the length of bobbin thread remaining on the bobbin and properly modify the value on the counter. Increasing the counter value by 1 will shorten the remaining length of bobbin thread by the amount that is used for a sewing cycle. The remaining length of bobbin thread at the time when the indication of run-out of bobbin thread appears vary by a certain extent. The extent of variation depends on the type of thread, sewing length and adjustment of the bobbin winder. The remaining length of bobbin thread is shown, as a guide, in the table below. Correct the counter value in accordance with sewing conditions so that the bobbin thread does not completely run out during sewing. (The table shows the counter value when the data on L-size sewing is set to 150.) <table border="1" data-bbox="553 1207 1197 1407"> <thead> <tr> <th>Thread count</th> <th>Counter value</th> <th>Bobbin thread remaining length for reference (m)</th> </tr> </thead> <tbody> <tr> <td>#40</td> <td>1</td> <td>0.4 ~ 2.6</td> </tr> <tr> <td>#50</td> <td>2</td> <td>0.2 ~ 2.6</td> </tr> <tr> <td>#60</td> <td>2</td> <td>0.2 ~ 2.8</td> </tr> <tr> <td>#80</td> <td>3</td> <td>0.1 ~ 3.0</td> </tr> </tbody> </table> <p>(Caution) The bobbin thread remaining length has to be re-adjusted in the case described below.</p> <ol style="list-style-type: none"> When the sewing length (L-size) for the sewing product has been changed When the thread count of bobbin thread has been changed <p>(Caution) The value on the bobbin thread remaining amount counter is cleared by inputting a value on the bobbin thread remaining amount adjusting counter.</p> <ol style="list-style-type: none"> If the bobbin has run out of thread, the bobbin thread remaining amount detecting device is incapable of performing "bobbin thread remaining amount detection." So, it is very important to specify a value on the bobbin thread remaining amount adjusting counter to allow the device to give the indication of "run-out of bobbin thread" when the sufficient amount of bobbin thread remains. Be sure to replace the empty bobbin with a bobbin fully wound with thread immediately after the aforementioned indication appears on the display. | Thread count | Counter value | Bobbin thread remaining length for reference (m) | #40 | 1 | 0.4 ~ 2.6 | #50 | 2 | 0.2 ~ 2.6 | #60 | 2 | 0.2 ~ 2.8 | #80 | 3 | 0.1 ~ 3.0 |
| Thread count | Counter value | Bobbin thread remaining length for reference (m) | | | | | | | | | | | | | | |
| #40 | 1 | 0.4 ~ 2.6 | | | | | | | | | | | | | | |
| #50 | 2 | 0.2 ~ 2.6 | | | | | | | | | | | | | | |
| #60 | 2 | 0.2 ~ 2.8 | | | | | | | | | | | | | | |
| #80 | 3 | 0.1 ~ 3.0 | | | | | | | | | | | | | | |



* Specified data (Input with the ten keys.)

| Panel indication | Function and operation |
|------------------|---|
| | <p>5. Adjustment screen</p> <ul style="list-style-type: none"> The following screen appears if pressing the "0" of the ten keys with the CYCLE key  kept pressed. This screen is used to specify and adjust the mechanisms of sewing machine. <div style="text-align: center;">  </div> <p style="text-align: center;">Example of the Adjustment screen 1</p> <ul style="list-style-type: none"> Four different pictographs are shown on the single screen. The pictograph numbers are shown above the respective pictographs. <div style="display: flex; justify-content: space-between;"> <div style="width: 45%;"> <p>Pictograph No. </p> <p>Pictograph No. </p> </div> <div style="width: 50%;"> <p>Alphabet B on the left-hand side indicates the adjustment screen.</p> <p>Alphabet A on the right-hand side indicates the pictograph number. (A through L)</p> <p>The angle brackets < > change by pressing the SCREEN CHANGE-OVER key .</p> <p>The brackets [] do not change by pressing the SCREEN CHANGE-OVER key .</p> </div> </div> |

| Panel indication | Function and operation |
|--|--|
| | <div style="display: flex; justify-content: space-between;"> <div style="width: 20%;"> <p><BA> 0.00</p> <p><BB> Darts OPTION OFF</p> <p><Bb> SPEED Lo</p> <p>[Bc] 0</p> <p><BC> 0</p> <p>[BE] 0.80</p> <p>[BF] 0.80</p> <p>[BG] High 2200</p> <p>[BH] Low 1500</p> <p><BI> M-0</p> <p>[BJ] 0-1 2.00</p> <p>[BK] 0-2 2.00</p> <p>[BL] Check PGM. Mode 0</p> </div> <div style="width: 70%;"> <p>1</p> <p>2</p> <p>3</p> <p>Returns to the initial state</p> <p>Returns to the initial state</p> <p>Returns to the initial state</p> <p>M-1</p> <p>M-2</p> <p>M-3</p> <p>M-4</p> <p>Returns to the initial state</p> </div> </div> |
| <p>The clamp foot return mode</p> <p>Setting of dart stretcher operation</p> <p>Supplying device</p> <p>Change-over of interlining feeding speed of the automatic interlining</p> <p>Length of extra interlining feeding</p> <p>Timing of needle thread trimming</p> <p>Slacker timer 1</p> <p>Slacker timer 2</p> | <p>Setting the sewing speed for lockstitching</p> <p>Setting the sewing speed for condensation stitching or backtacking</p> <p>Sewing machine independent operation mode</p> <p>Sewing machine independent operation ON time</p> <p>Sewing machine independent operation OFF time</p> <p>Check program</p> |
| <p>(Pictographs marked by arrows (↑ • ↓) can be changed over using the SCREEN CHANGE-OVER key .)</p> | <p>(Specified data are the standard values.)</p> |

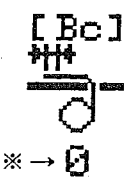
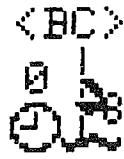

| Panel Indication | Function and operation |
|---|---|
|  | <p>: The position of the clamp foot is changed over after the completion of sewing. = Stops at the front end (Data setting range: 0 to 9.99 sec.)</p> <ul style="list-style-type: none"> • Length of time during which the clamp foot stops at the sewing end position is set. <p>* Specified data (input with the ten keys)</p> <p>1  : The position of the clamp foot is changed over after the completion of sewing. = Returns to the middle position</p> <p>2  : The position of the clamp foot is changed over after the completion of sewing. = Returns to the home position</p> <p>3  : The position of the clamp foot is changed over after the completion of sewing. = Stops at the rear end</p> |
|  | <p>: Dart stretcher is inoperative.</p> |
|  | <p>: Dart stretcher is operative. (Optionally available)</p> |
| <p>(Note)</p>  | <p>: Interlining feeding speed of the automatic interlining supplying device is set to the low speed. (Approx. 600 mm/sec.) (Select the low speed in the case where slippery interlining is used.)</p> |
|  | <p>: Interlining feeding speed of the automatic interlining supplying device is set to the medium speed. (Approx. 900 mm/sec.) (Select the medium speed in the case where general interlining is used.)</p> |
|  | <p>: Interlining feeding speed of the automatic interlining supplying device is set to the high speed. (Approx. 1,200 mm/sec.) (Select the lower speed in the case where light-weight interlining that is not slippery is used.)</p> |

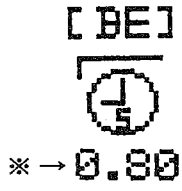
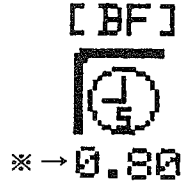
(Note) This indication is shown on the display when an automatic interlining supplying device (optional) is used.



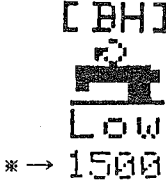

| Panel indication | Function and operation |
|---|--|
|  | <p>(Note)</p> <p>: Length of extra interlining feeding Automatic interlining supplying device feeds the total length of sewing length + (plus) 40 mm + (plus) panel set value when the device is used. (Data setting range 0 to 99 mm)</p> |
|    | <p>: Timer of the thread trimmer (standard timing)</p> <p>: Timer of the thread trimmer (intermediate timing: Standard position + Approx. 10 mm)</p> <p>: Timer of the thread trimmer (latest timing: Thread trimmer actuates when the clamp foot stops at the position of the corner knife.)</p> |
|  | <p>: Stacker timer 1 (unit: second) (Data setting range: 0.00 to 9.99 sec.)</p> <ul style="list-style-type: none"> • For a grasping stacker: The period of time during which the stacker grasps the workpiece is specified. • For a bar stacker: The period of time during which the stacker grasps the workpiece is specified. (• For a roller stacker: The period of time during which the roller actuates is specified. (If a material sensor is used with the machine, specify 9.99.) |
|  | <p>: Stacker timer 2 (Data setting range: 0.00 to 9.99 sec.)</p> <ul style="list-style-type: none"> • For a grasping stacker: The period of time during which the stacker swings is specified. • For a bar stacker: The period of time during which the stacker swings is specified. (• For a roller stacker: Not used.) |

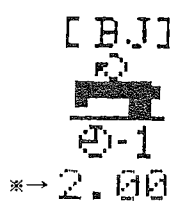
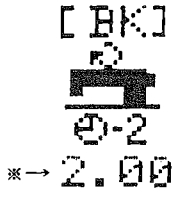
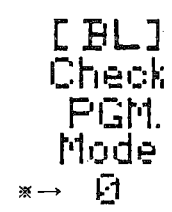

* Specified data (Input with the ten keys.)

(Note) This indication is shown on the display when an automatic interlining supplying device (optional) is used.

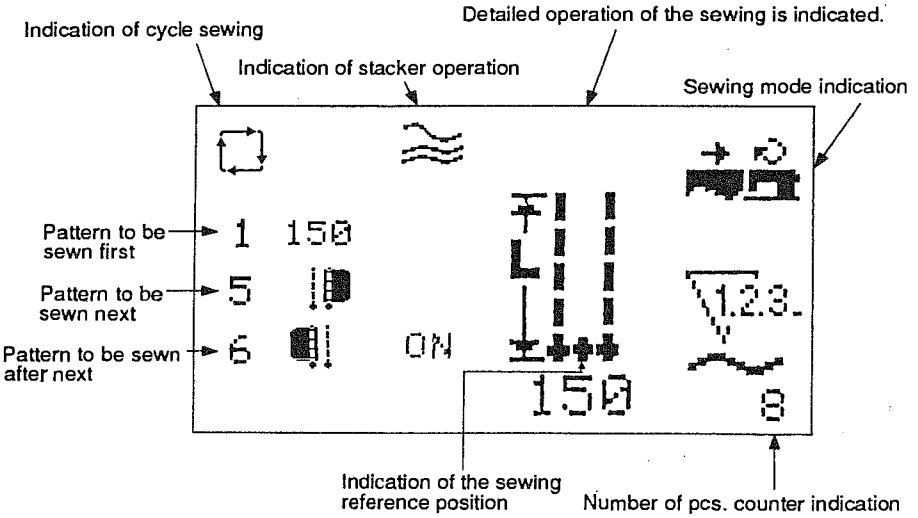
| Panel Indication | Function and operation |
|--|--|
|  | <p>: Setting of the sewing for lockstitching Recommendable value for data setting: 2,500 rpm (Data setting range: 1,000 to 2,500 rpm)</p> |
|  | <p>: Setting of the sewing speed for condensation stitching or backtacking Recommendable value for data setting: 1,500 rpm (Data setting range: 500 to 2,500 rpm)</p> |
|  | <p>: Sewing machine independent operation mode is set. Start the independent operation of the machine using the DIP switches. : No operation</p> <p>: Continuous high-speed operation of sewing machine</p> <p>: Continuous low-speed operation of sewing machine</p> <p>: Intermittent high-speed operation of sewing machine</p> <p>: Intermittent low-speed operation of sewing machine</p> |

* Specified data (Input with the ten keys.)

| Panel indication | Function and operation |
|---|---|
|  | <p>: The period of time during which the sewing machine is in its "ON" state in the sewing machine independent operation mode or in the intermittent operation mode. (Data setting range: 1.00 to 9.99 sec.)</p> <p>The sewing machine independent operation mode starts up using the DIP switch. (If the specified value is 1.00 sec. or smaller, the sewing machine does not operate.)</p> |
|  | <p>: The period of time during which the sewing machine is in its "OFF" state in the sewing machine independent operation mode or in the intermittent operation mode. (Data setting range: 1.00 to 9.99 sec.)</p> <p>The sewing machine independent operation mode starts up using the DIP switch. (If the specified value is 1.00 sec. or smaller, the sewing machine does not operate.)</p> |
|  | <p>: Check program mode is specified. (Available modes are 0, 1, 2, 3, 4, 6, 8 and 9.)</p> <p>The check program is started up by pressing the SCREEN CHANGE-OVER key .</p> |
| <p>② LCD indication under the automatic mode</p> | <p>1) The following screen is given under the automatic mode.</p> <div style="text-align: center;">  </div> <ul style="list-style-type: none"> • If the screen shown above is given on the LCD, only the MACHINE READY key  is operative. |

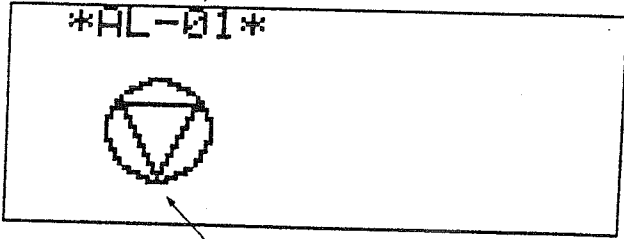
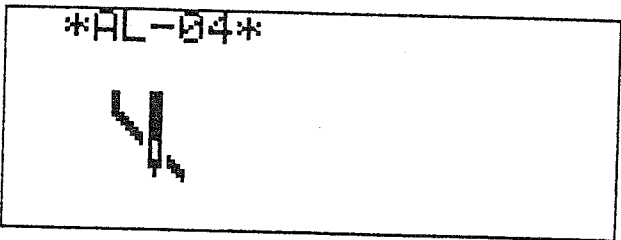
| Panel Indication | Function and operation |
|---------------------------|--|
| | <p>2) Example of the indication showing detailed operation of sewing</p> <p>Example 1)</p>  <ul style="list-style-type: none"> • Parallel L size sewing • Resr reference sewing <p style="text-align: right;">L size = 120 mm</p> <p>Example 2)</p>  <ul style="list-style-type: none"> • Right parallel flap sewing |
| <p>③ Alarm indication</p> | <p>When an alarm occurs, the machine immediately stops. The alarm number corresponding to the alarm occurred flashes on and off on the LCD display unit to show that the machine stops in the alarm state.</p> <p>1) Temporary stop</p> <div style="text-align: center;">  <p style="margin-left: 100px;">Alarm number</p> <p style="margin-left: 100px;">Pictograph corresponding to the temporary stop</p> </div> <p>Pressing the RESET key R releases the machine from the alarm state.</p> <p>2) Thread breakage detection</p> <div style="text-align: center;">  <p style="margin-left: 100px;">Alarm number</p> </div> <p>Pressing the RESET key R releases the machine from the alarm state.</p> |

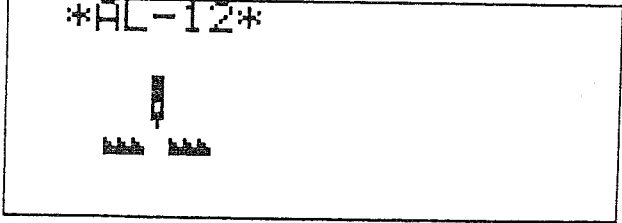
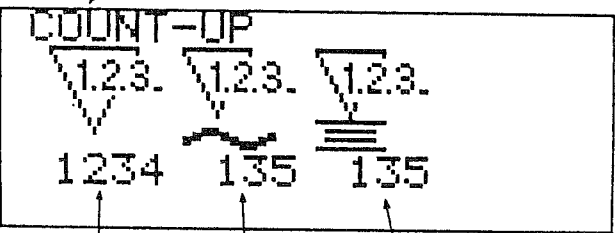
| Panel indication | Function and operation |
|--|--|
| | <p>3) The thread take-up lever is not in its highest dead position.</p> <div style="text-align: center;"> <p>Alarm number</p>  </div> <p>(Caution) The AL-12 is reset following the procedure described below.</p> <ol style="list-style-type: none"> 1. Turn the handwheel to make the thread take-up lever go up to its highest dead point when the clamp foot is in its front end or rear end. At this time, the machine is automatically released from the alarm. 2. Turn the handwheel to make the thread take-up lever go up to its highest dead point when the clamp foot is in its intermediate position. Then press the RESET key R. |
| <p>④ Bobbin thread count-up indication</p> | <p>1) When the figures on the number of pieces counter becomes equal to the figures displayed on the bobbin thread counter, the following screen appears. Press the RESET key R, and the figures shown on the number of pieces counter will be cleared (number = 0) and the cycle screen will be shown on the LCD display unit.</p> <div style="text-align: center;"> <p>The display of "count-up" flashes on and off.</p>  </div> <div style="text-align: center;"> <p>Total counter Number of pcs. counter Bobbin thread counter</p> </div> |

| Panel indication | Function and operation |
|--|---|
| <p>⑤ Panel indications for the bobbin thread remaining amount detecting unit</p> | <p>1) While the bobbin thread remaining amount counter is appearing on the panel</p> <p>When the remaining amount of the bobbin thread is decreased to such an extent as to make the sensor to perform detection, the indication on the screen changes from the No. of pcs. counter over to the bobbin thread remaining amount counter that shows the possible No. of times to be sewn until "No bobbin thread" message appears (the machine stops sewing). If you continue sewing in the aforementioned state, the value shown on the bobbin thread remaining amount counter decreases one by one every time the sewing is performed. (In the case where data on the bobbin thread remaining amount adjusting counter has been set to "0," the bobbin thread remaining amount counter will not be given on the screen.)</p> <div data-bbox="591 428 1197 663" data-label="Image"> </div> <p style="text-align: center;">Indicated value of the bobbin thread remaining amount counter</p> <p>(Caution) When the bobbin thread remaining amount counter is cleared from the screen, the No. of pcs. counter will be restored.</p> <p>2) Indication of "No bobbin thread" message and resetting procedure</p> <p>When the bobbin thread remaining amount counter gives "0" and the bobbin thread remaining amount has reduced to the set value or less, the screen shown below will appear.</p> <p>Replace the bobbin corresponding to the flashing one on the screen with a new one.</p> <p>Press the R (reset) key, and the "No bobbin thread" message will be reset to restore the cycle screen.</p> <p>If the ○ (MACHINE READY) key is pressed, the "No bobbin thread" message will be reset and the automatic mode screen will appear.</p> <div data-bbox="579 984 1182 1220" data-label="Image"> </div> <p>(Caution)</p> <ol style="list-style-type: none"> 1. The pictograph corresponding to the run-out bobbin flashes on and off. 2. Once the "No bobbin thread" message appears, replace the bobbin at all times. 3. Replace the bobbin and start sewing, and the bobbin thread remaining amount counter will automatically cleared from the screen. |

(3) Example of setting data on cycle sewing











Let's set data on the following example.

- Pattern No. 1
 - L size sewing 150 mm
- Pattern No. 5
 - Left-flap sewing with the stacker actuated.
- Pattern No. 6
 - Right-flat sewing with the stacker actuated.

Step 1. Specify data on cycle sewing.

Under the manual mode (when the mode indicator LED goes out), press the CYCLE key , then press 1, 5 and 6 numeric keys in the written order successively. This completes the setting of data on cycle sewing (1, 5 and 6).

Step 2. Specify data on sewing pattern.

- After step 1, press the SCREEN CHANGE-OVER key  (when the cycle screen is shown on the LCD). Then the sewing pattern screen will appear on the LCD.
 - Then, press the 1 of the numeric keys, and the sewing pattern of pattern No. 1 will be shown on the LCD.
- 2-1 Changing the sewing pattern corresponding to pattern No. 1
- Press the CURSOR shift key  to change the flashing pictograph (item that can be modified). Then press the SCREEN CHANGE-OVER key , and the flashing pictograph will be changed to another (the specified data will be changed to another).
 - Operate the , numeric keys to set data to the values same as those of pattern 1 to the described on the next page.
- 2-2 Change the sewing pattern of pattern No. 5
- Keep pressing the CURSOR shift key  until the pictograph number [1A] flashes on and off. Then, press the 5 of numeric keys.
 - Operate the CURSOR shift key , SCREEN CHANGE-OVER key  and numeric keys to set data to the values same as those of pattern 5 to the described on the next page.
- 2-3 Changing the sewing pattern of pattern No. 6
- Keep pressing the CURSOR shift key  until the pictograph number [5A] flashes on and off. Then, press the 6 of numeric keys.
 - Operate the CURSOR shift key , SCREEN CHANGE-OVER key  and numeric keys to set data to the values same as those of pattern 6 to the described on the next page.

• Set values of pattern 1

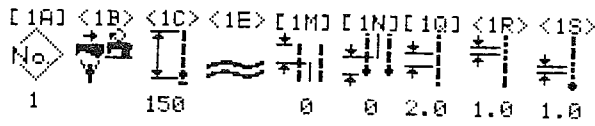

• Set values of pattern 5

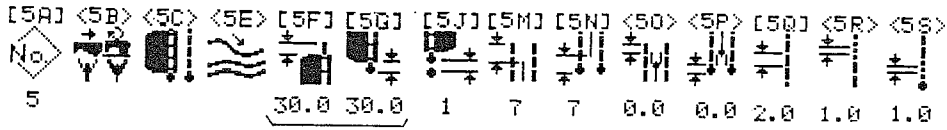

Change the data on flap concealed stitching in accordance with the flap to be sewn.

• Set values of pattern 6

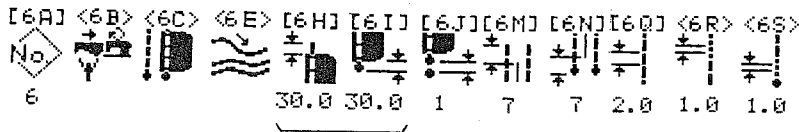

Change the data on flap concealed stitching in accordance with the flap to be sewn.

Step 3. Confirming data on cycle sewing

Press the CYCLE key , and confirm that the following indication is given on the LCD.

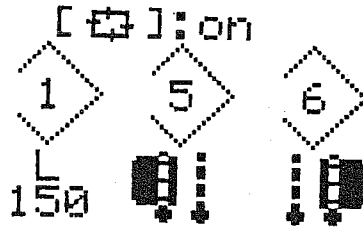

Press the MACHINE READY key , and the machine will operate under the automatic mode. Now, the sewing machine can start sewing.

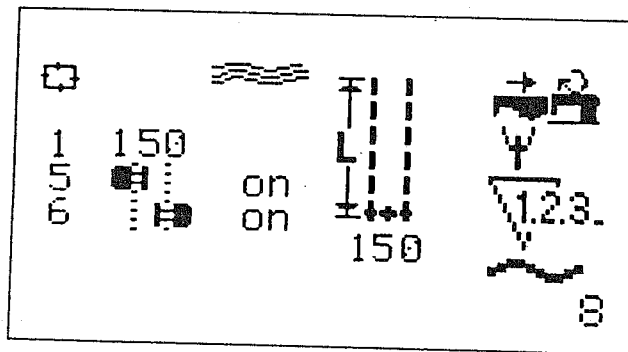

V. MAINTENANCE

1. INSPECTION

Inspect your machine periodically and maintain it in the following ways in order to maintain the machine in good conditions at all times. If not, mechanical failures may result. So be sure to inspect and perform maintenance work periodically.

(1) Maintenance and inspection of the pneumatic systems



WARNING:

To protect against possible accidents due to abrupt start of the machine, keep your hands, fingers and face from moving parts of the main unit of the machine and place no tool near them.

- Drain the air filter every day.

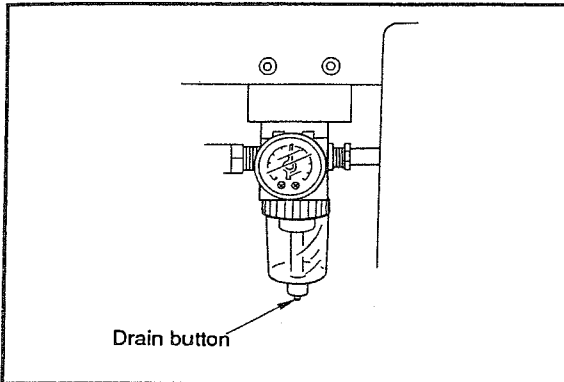

Push up the drain button on the bottom of the air filter, and the water gathered in it will come out.

(2) Maintenance and inspection of the sewing machine components



WARNING:

Turn OFF the power before starting the work so as to prevent accidents caused by abrupt start of the sewing machine.

- When dust is accumulated in the machine head including the clamp foot, malfunction may result. Be sure to clean up the sewing components including the clamp foot every day before the operation. Remove dust and wastes from the oil pan at least once a week.
- Before you start operation, check sharpness of the center knife and corner knife. It is recommendable to renew the knives earlier.
- Be sure to inspect the lubrication of the sewing machine once a month periodically. Be sure to use the oil designated by JUKI.

(3) Maintenance and inspection of the electrical systems



DANGER:

To protect against shock hazards, if the electrical box needs to be opened, turn OFF first the power to the machine and wait for five minutes or more for safety's sake.

- Connectors are subject to loosen due to the mechanical vibration transmitted from the machine head. So be sure to check the connectors for tight connection once a month.
- Attach and detach the printed circuit board after turning OFF the power switch.
- Do not touch the connection of the printed circuit board.

2. CROSS MARK LAMPS



WARNING:

To avoid hazards from burns due to contact on hot parts, do not allow your hands to come in direct contact with the lamp.

(1) Cross (+) mark lamps for setting sewing

There are two cross (+) mark lamps. A lamp closer to the operator is used to determine the point (rear reference and seam ends) and the other lamp on the far side is used to determine the point at which a seam starts (front reference) and adjust the parallelism of the workpiece.

① How to adjust the irradiation position of the cross (+) mark lamps

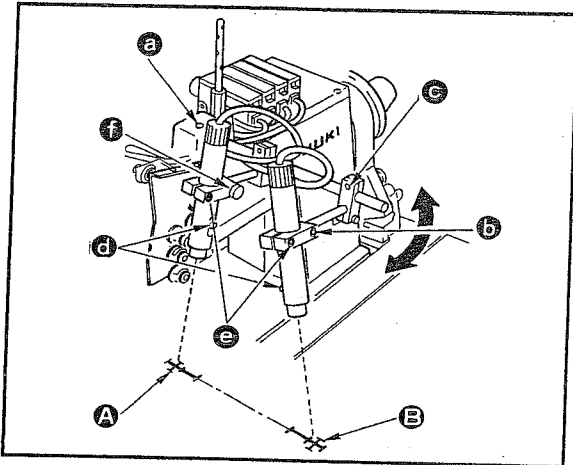

Adjust the cross (+) mark lamps irradiation point in the following steps of procedure.

- 1) Set the machine to its predetermined position, and turn ON the power switch. (The cross (+) mark lamps light up.)
- 2) First adjust the lateral position of the cross (+) mark lamps referring to parallelism checking cross mark lamp light (A). Loosen setscrew (B), and slide the entire unit of the cross mark lamps in the direction of the arrow until cross mark lamp (A) on the far side irradiates the middle point between two needles. Now re-tighten setscrew (B).

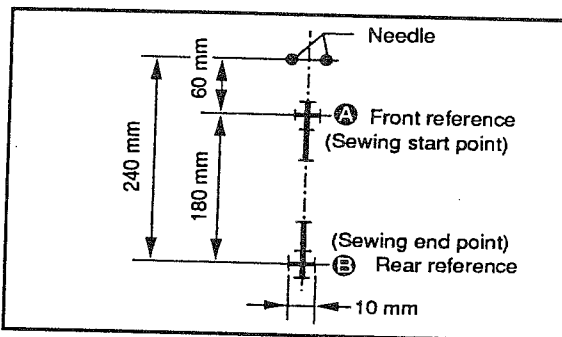

- 3) Loosen setscrews (C), (D) and (E) in the cross mark lamp on the near side. This cross mark lamp is used to determine the rear reference for sewing. Now adjust the position of lamp (B) so that it irradiates point B as illustrated in the figure.

The distance from the needle to the lamp should be 240 mm.

- 4) Lastly, loosen mark lamp clamp screws (E) and setscrew (D), and adjust the height of the lamps to bring the cross mark images into the sharpest focus having the width of 10 mm. Now firmly tighten clamp screw (E) and setscrew (D).
- 5) After the adjustment of the focus, be sure to confirm that the proper distance (240 mm) is provided between the needle and the lamp and that the cross mark images projected by the lamps are aligned with the middle line between the needles.

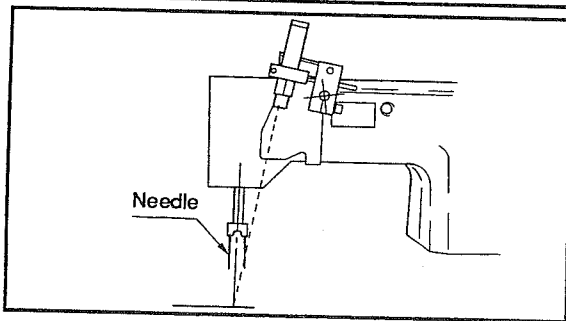

② How to replace the bulb in the cross mark clamp



WARNING:

To avoid hazards from burns due to contact on hot parts, turn OFF the power to the machine and carry out the work after the lamp has cooled off.

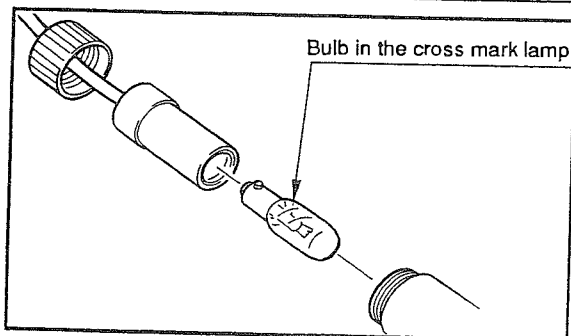

Disassemble the lamp unit as illustrated in the figure. Replace the bulb with a new one, and then reassemble the lamp unit accordingly.

3. LUBRICATION



WARNING:

Turn OFF the power before starting the work so as to prevent accidents caused by abrupt start of the sewing machine.

(1) Lubrication of the face plate

To lubricate the face plate, fill lubrication oil from oil filler port **A** up to red marker dot **C** in oil sight window **B**.

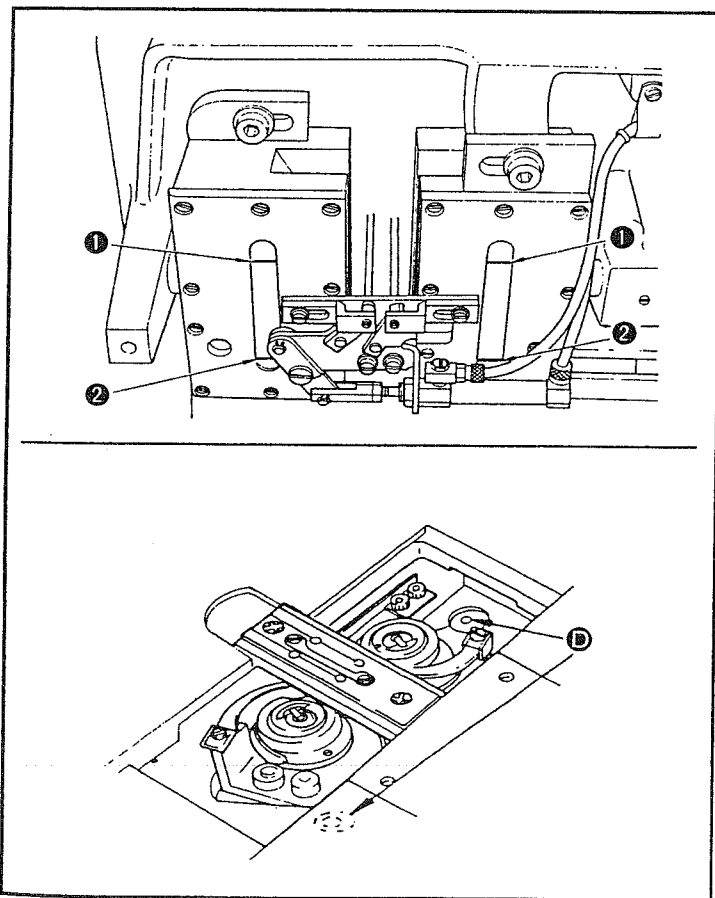
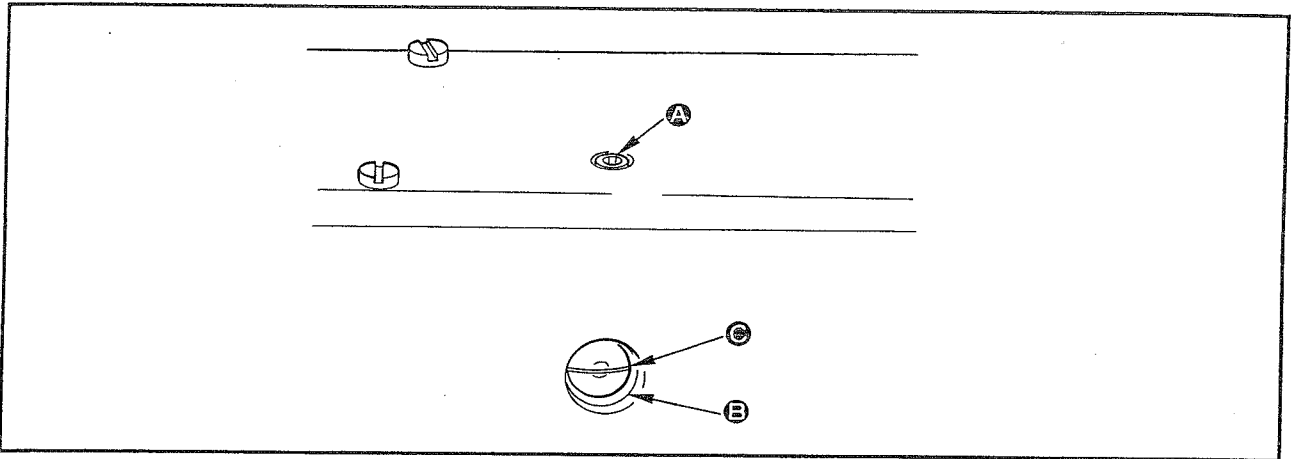

(2) Lubrication of the hooks

Supply the industrial machine oil (JUKI New Defrix Oil No. 2) from oil holes **D** using oil feeder.

The oil should be filled up to marker line **1** engraved on the gauge.

* The right- and left-hand hooks are lubricated in the same procedure. For the right-hand hook, however, check the amount of oil by turning OFF the air supply to the machine and moving the bobbin thread trimming mechanism in the direction of the arrow if the marker line engraved on the gauge cannot be observed with ease.

(Caution) When the oil level decreases to marker line **2** or lower, stop running the sewing machine and refill the lubricating oil up to the proper level.

Periodically inspect lubrication of the hooks.

4. HOW TO CHANGE OVER THE TYPE OF WELT; DOUBLE-WELT, SINGLE-WELT OR VARIABLE DOUBLE-WELT



WARNING:

Turn OFF the power before starting the work so as to prevent accidents caused by abrupt start of the sewing machine.

(1) Binder components

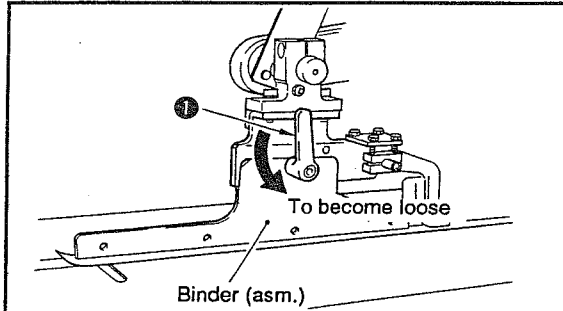

Loosen screws ①, and replace the binder (asm.) in accordance with the type of welt to be sewn.

(Caution) Securely tighten the knob of screw ①. Be sure to fix the knob with faced upward as shown in the sketch on the left.

(2) Clamp foot components

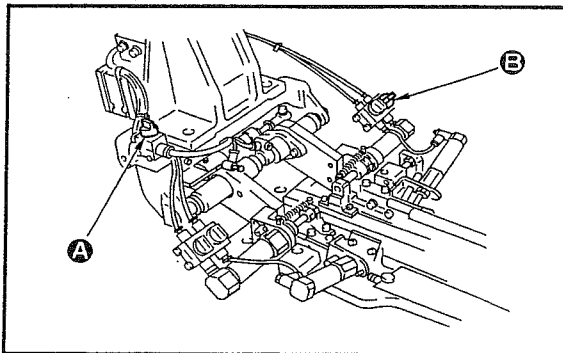

Change over mechanical valve ①A to change of position of the clamp foot.

(3) Switching the folding plate

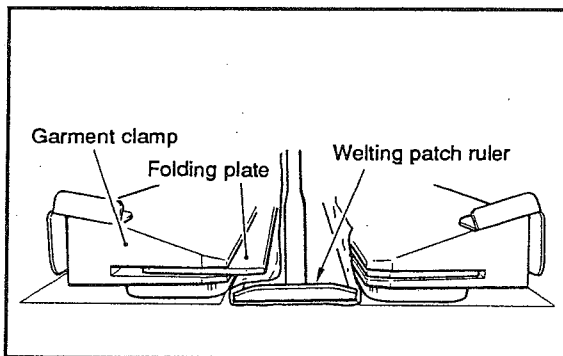



As illustrated in the sketch on the left, switch over mechanical valve ①B (see the illustration given above) when sewing single-welts without using the folding plates.

Once the mechanical valve has been changed over, the folding plates are inoperative.

5. HOW TO ADJUST THE FOOT PEDAL

This foot pedal is so designed that a variable resistor (volume) detects the depressing depth of the foot pedal and the resistance of the resistor is taken as the operation step of the pedal. However, the resistance of the variable resistor changes with a lapse of time. As a result, the operation step of the pedal can fail to match the depressing depth of the foot pedal. In this case, adjust the foot pedal taking the following procedure.

Resistances and the operation steps of the foot pedal are stored in memory of the CPU board. So, if the CPU board or the foot pedal is replaced or the data stored in memory of the CPU board is all erased, adjust the foot pedal taking the same procedure.

- 1) Operate the adjustment screen (by pressing the "0 (zero)" key of the numeric keys while keeping the  CYCLE key held pressed) so that Pictograph No. [BL] "Check program" is shown on the operation indicating portion of the display.
- 2) Press the "9" key of the numeric keys. Then, press the  SCREEN CHANGE-OVER key to start the check program mode 9.

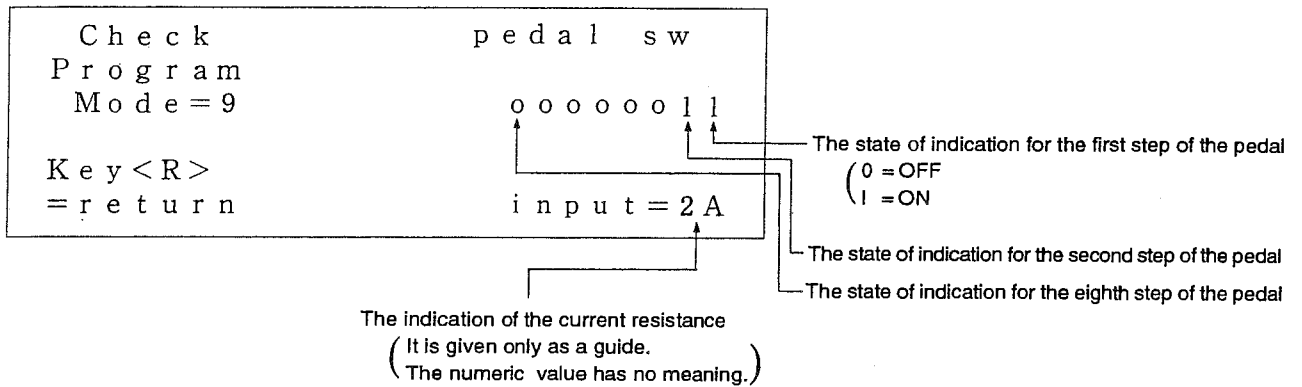

- 3) To allow the CPU board to record the released state of the pedal, press the "0 (zero)" key of the numeric keys with the foot pedal released.

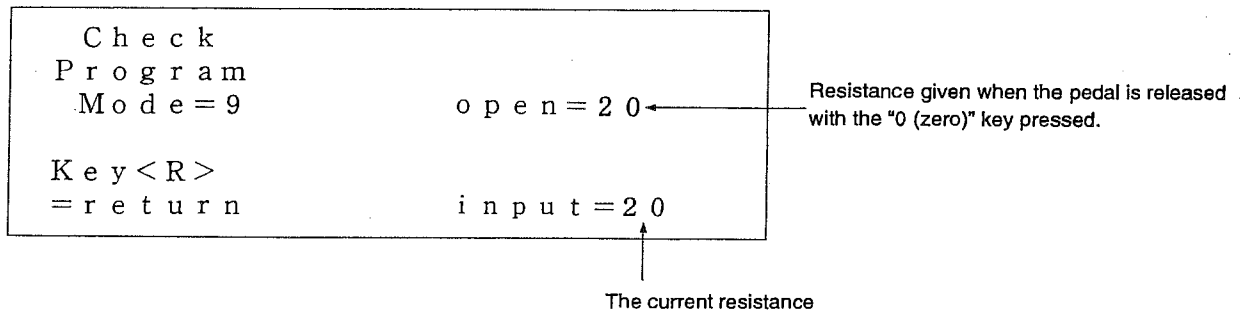

- 4) Perform following operation to allow the CPU board to record the position of number of respective steps of the 6-step foot pedal.
- Press the ① key of the numeric keys with the 1st step of the foot pedal depressed,
 Press the ② key of the numeric keys with the 2nd step of the foot pedal depressed,
 Press the ③ key of the numeric keys with the 3rd step of the foot pedal depressed,
 Press the ④ key of the numeric keys with the 4th step of the foot pedal depressed,
 Press the ⑤ key of the numeric keys with the 5th step of the foot pedal depressed,
 And press the ⑥ key of the numeric keys with the 6th step of the foot pedal depressed.
 (If the 6th step is not provided, press the ⑥ key of the numeric keys at the 5th step position.)
 The positions of the respective steps (registance of the resistor) are recorded through the abovementioned steps. (Note 1)

```

Check
Program
Mode = 9           p e d a l = 1

Key < R >
= r e t u r n      i n p u t = 3 0
  
```

- 5) Press the **R** (reset) key to terminate the check program.

Note 1 : Be sure to record the position of the foot pedal starting from the 1st step to the 6th step in order. If the recording stops on the way, the setting data recorded till that time will be cancelled.

The position where the foot pedal is depressed is recorded as the number of steps. When desired to simultaneously operate the 1st and 2nd steps of the foot pedal, set the foot pedal at the same position, and press the ① and ② keys of the numeric keys.

As the number of steps of the foot pedal increases, set the foot pedal at the same depressing position or depress more strongly the foot pedal.

6. SPECIFYING THE SENSITIVITY OF THE SENSOR AMPLIFIER FOR DETECTING FLAPS

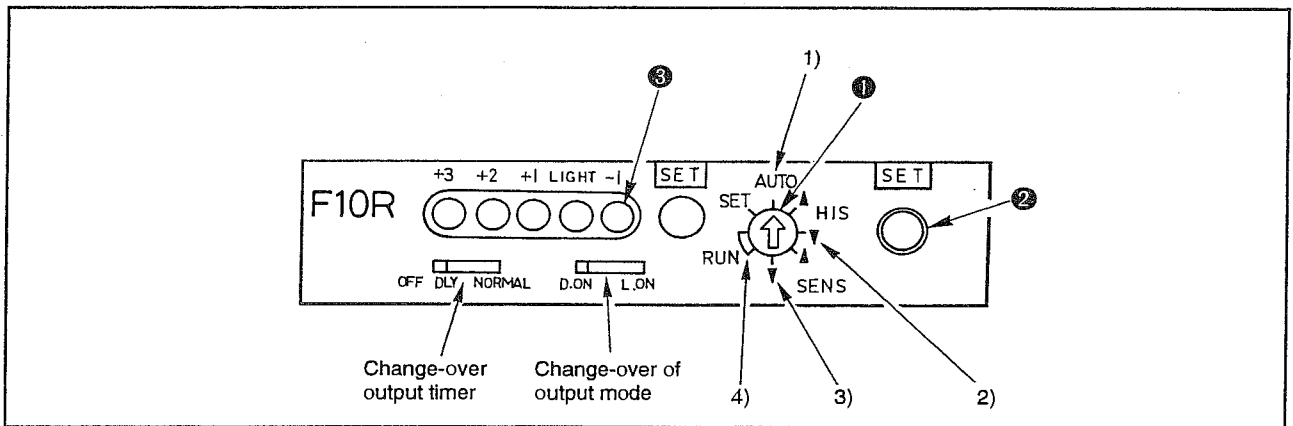

- 1) Set rotary switch ① to the "AUTO."
 Adjust first so that the spot of light falls on the reflecting tape and press the SET button.
 The adjust so that the spot of light falls on the fabric and press SET button ②.
- 2) Set rotary switch ③ to the "SENS ▲ ."
 When the spot of light falls on the fabric, press SET button ② several times until green indicator lamp ③ locating under the indication "-1" lights up.
- 3) Set rotary switch ④ to "SENS ▼ ."
 Press SET button ② by seven times.
- 4) Set rotary switch ④ to the "RUN" to terminate the setting. There are two calibration markings for "RUN." You may set the rotary switch either of them.

7. ADJUSTING THE SENSITIVITY OF THE AMPLIFIER OF THE BOBBIN THREAD REMAINING AMOUNT DETECTING SENSOR

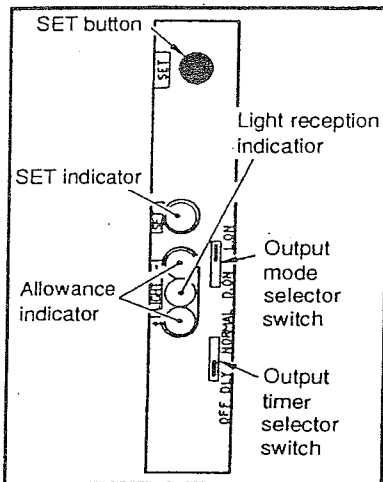

- 1) Energize the power to the main unit of the sewing machine.
 - 2) Remove the cover from the sensor amplifier.
 - 3) Confirm that the output timer selector switch is set to "OFF DLY" and that the output mode selector switch is set to "L.ON."
 - 4) Set an empty bobbin on the sewing machine and turn the bobbin so that the sensor light irradiates the most on the reflecting sheet.
 - 5) Set the sewing table in position and press the SET button on the sensor amplifier once. The SET button flashes on and off to show that a piece of data has been stored in memory.
 - 6) Replace the empty bobbin with one that is fully wound with thread. Then set the bobbin and bobbin case in the sewing machine. It is recommended to use white thread.
 - 7) Set the sewing table in position and press the SET button on the sensor amplifier once. The SET indicator lamp lights up continuously to show the completion of the sensitivity adjustment.
 - 8) Attach the cover to the sensor amplifier.
- Perform the aforementioned steps of procedure respectively for the left and right bobbins.

8. CAUSES AND CORRECTIVE MEASURES AGAINST TROUBLES WITH THE BOBBIN THREAD REMAINING AMOUNT DETECTING DEVICE

| Phenomenon | Cause | Corrective measure |
|--|---|---|
| 1. The bobbin thread remaining amount detecting function fails to work even when the bobbin thread has run out. | <ol style="list-style-type: none"> ① The bobbin thread remaining amount adjusting counter has been improperly set. ② The start position of bobbin winding is defective. ③ The sensitivity of the sensor amplifier has been improperly adjusted. ④ The sensor amplifier fails to turn ON/OFF because of the stained lens. ⑤ The installing position of the optical fiber unit and optical fiber unit BKT bracket is defective. ⑥ The bobbin used is not the exclusive one for the bobbin thread remaining amount detecting device. ⑦ The bobbin case used is not the exclusive one for the bobbin thread remaining amount detecting device. ⑧ The bobbin winder fails to wind the bobbin uniformly. ⑨ The sensor cable connection failure ⑩ The optical fiber connection failure | <ul style="list-style-type: none"> ○ Check the specified data on the bobbin thread remaining amount adjusting counter. ○ Start winding a bobbin from the recess designated. ○ Check the sensitivity of the sensor amplifier. ○ Check whether the solenoid valve for the bobbin thread remaining amount detecting device operates normally. ○ Wipe clean the lens surface of the optical fiber unit. ○ Check that the spot of sensor light irradiates the correct portion. ○ Use the exclusive bobbin for the bobbin thread remaining amount detecting device. ○ Use the exclusive bobbin case for the bobbin thread remaining amount detecting device. ○ Properly adjust the bobbin winder. ○ Check how the sensor cable and the CPU circuit board are connected. ○ Check how the optical fiber unit and the sensor amplifier are connected. |
| 2. The bobbin thread remaining amount detecting function works though the bobbin still has enough thread. | <ol style="list-style-type: none"> ① The bobbin thread remaining amount adjusting counter has been improperly set. ② The sensitivity of the sensor amplifier has been improperly adjusted. | <ul style="list-style-type: none"> ○ Check the specified data on the bobbin thread remaining amount adjusting counter. ○ Check the sensitivity of the sensor amplifier. |
| 3. The pictograph  corresponding to the bobbin thread remaining amount detecting function fails to be shown on the display. | <ol style="list-style-type: none"> ① The machine has not been set to the state where the bobbin thread remaining amount detecting device is to be mounted on it. | <ul style="list-style-type: none"> ○ Properly set the DIP switch on the CPU circuit board. <p>Procedure</p> <ul style="list-style-type: none"> • Turn OFF the power to the machine. <li style="text-align: center;">↓ • Set the DIP SW-5 to the ON position. <li style="text-align: center;">↓ • Re-turn ON the power to the machine. |

9. EXPLANATION OF VARIABLE RESISTORS AND DIP SWITCHES

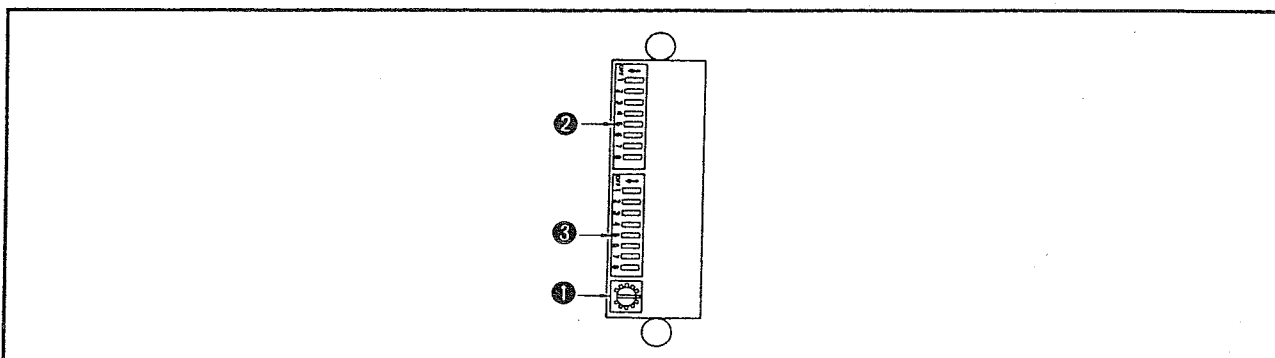

(1) Explanation of function

① VR (Variable Resistor)

This variable resistor is used to adjust clearness of the liquid crystal display screen. The clearness of the liquid crystal display screen subtly changes in accordance with the viewing angle and ambient temperature. So adjust it with this variable resistor.

② DIP 1

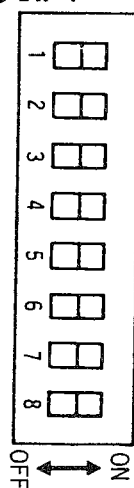

1 Widening data input range, stopping output of alarms in part

OFF: Standard / ON: Widens the data input range, and stops output of AL-50 through AL-55.

2 Always set to OFF.

3 Switching between with/without Thread breakage detector

OFF: Without detector / ON: With detector

(Caution) In the case where the sewing speed for lockstitching corresponding to pictograph No. [BG] is set to 1,400 rpm or less, the thread breakage detector will not function even if the switch is set to ON: (With detector.)

WARNING:



To protect against possible accidents due to abrupt start of the machine, keep your hands, fingers and face from moving parts of the main unit of the machine and place no tool near them.

4 Stacker independent operation

OFF: Stops / ON: Stacker actuates

WARNING:



To protect against possible accidents due to abrupt start of the machine, keep your hands, fingers and face from moving parts of the main unit of the machine and place no tool near them.

5 Corner knife independent operation:

OFF: Stop / ON: Corner knife origin retrieval

WARNING:



To protect against possible accidents due to abrupt start of the machine, keep your hands, fingers and face from moving parts of the main unit of the machine and place no tool near them.

6 Sewing machine independent operation

OFF: Stop / ON: Sewing machine operates

(Caution) The data specified using the DIP switches are read at the time when the MACHINE READY key is pressed (change-over from the manual mode to the automatic mode). Consequently, the data will remain even if the setting of the DIP switches are changed when the machine is in the automatic mode.

③ DIP 2



WARNING:

Turn OFF the power before starting the work so as to prevent accidents caused by abrupt start of the sewing machine.

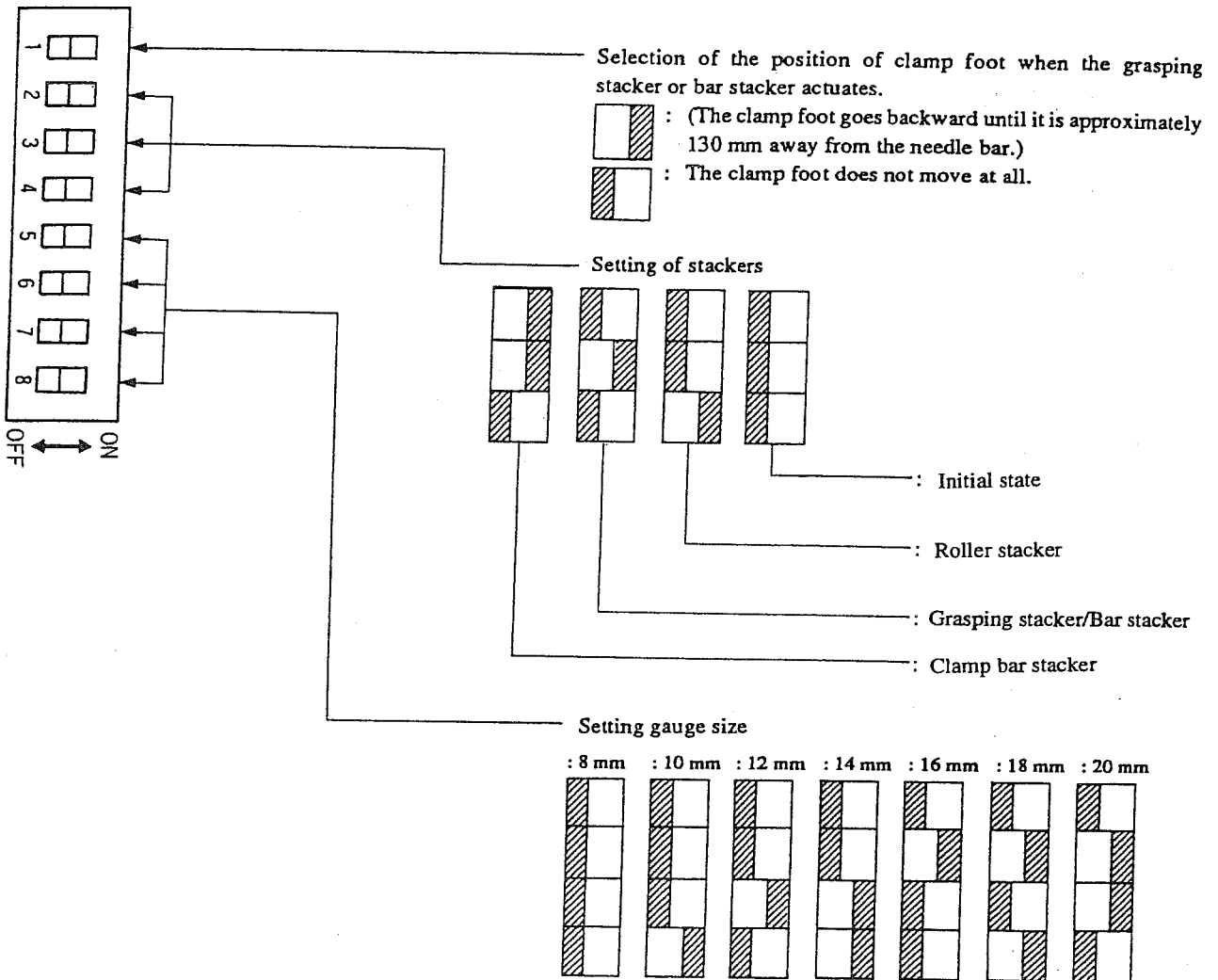

ENGLISH

(Caution) The data specified using the DIP switches are read at the time when the power to the machine is turned ON. So, be sure to change the setting of the above-stated DIP switches, if necessary, while the power to the machine is turned OFF.

(2) How to use the DIP switches



WARNING:

To protect against possible accidents due to abrupt start of the machine, firstly make sure that you have placed neither your hands, fingers, face nor any tool in moving parts of the main unit of the machine, then operate the DIP switches.

• DIP-1 SW-5 (stacker independent operation)

Setting the DIP switch to its ON position under the manual mode will actuate the stacker. To make the stacker inoperative, set the DIP switch to its OFF position.

• DIP-1 SW-8 (sewing machine independent operation)

The machine can be operated independently for adjustment. Independent operation of the sewing machine is possible when the clamp foot is in its rear end position under the manual mode.

VI. LIST OF ALARM CODES

WARNING:

To protect against possible accidents due to abrupt start of the machine, firstly make sure that you have placed neither your hands, finger, face nor any tool in moving parts of the main unit of the machine, then operate the switches keys.

| Alarm code | Description | Corrective measures | Time of detection | Remarks |
|------------|--|--|---|------------------------------------|
| AL-01 | TEMPORARY STOP switch is turned ON. | Press the RESET key. | Anytime | Momentary stop during operation |
| AL-02 | Servomotor or servomotor driver is defective. | Eliminate the cause of overload to the clamp foot, check whether the servomotor driver is defective and press the RESET key. | Anytime | Momentary stop during operation |
| AL-04 | Thread breakage is detected. | Press the RESET key, and check the needle thread. | During sewing | Momentary stop during operation |
| AL-05 | Step-out of the stepping motor for the corner knife | Eliminate the cause of overload to the corner knife feeding mechanism, and press the RESET key. | When the corner knife actuates. | |
| AL-09 | Failure in detection of the corner knife being in the lower end position. | Lower the corner knife, and press the RESET key. | When the clamp foot travels First step of the pedal switch | |
| AL-10 | Failure in detection of the center knife being in the upper end position. | Raise the center knife, and press the RESET key. | When the clamp foot travels First step of the pedal switch | |
| AL-11 | The binder is not in the correct position. | Check the operation of cylinder in the binder unit, then press the RESET key. | After turning ON the power to the machine When the clamp foot travels When the MACHINE READY key is pressed | |
| AL-12 | The thread take-up lever is not in its highest dead point. | Adjust the thread take-up lever to the highest dead point. | When the clamp foot travels When the MACHINE READY key is pressed When operating the pedal switch | |
| AL-13 | Dust gathers on the front end of the flap. | Remove dust from the reflection plate, and press the RESET key. | When the clamp foot feeds the material. | Only under the flap sewing mode. |
| AL-14 | Front end of the flap is not detected. | Press the RESET key, and place the flap properly on the machine. | When the clamp foot feeds the material. | Only under the flap sewing mode. |
| AL-15 | The corner knife cannot move from the current position. (The sewing length is too short.) | Press the RESET key. Change the sewing mode to another one under which the corner knife is not used. | When the MACHINE READY key is turned ON or when the machine has completed the sewing of a short flap. | |
| AL-16 | The flap sensor fails to receive light. | Remove dust from the reflection plate, and press the RESET key. | When the clamp foot starts feeding action. | Only under the flap sewing mode. |
| AL-17 | Failure in detection of the roller stacker being in the upper end position | Press the RESET key. | When the clamp foot is engaged in feeding action. | Only when a roller stacker is used |

| Alarm code | Description | Corrective measures | Time of detection | Remarks |
|------------|---|--|---|---|
| AL-18 | Failure in detection of the darts stretcher being in the upper end position | Press the RESET key. | When the MACHINE READY key is pressed. | The detection is made only when a darts stretcher is used |
| AL-19 | Binder is released. | Close the binder, and press the RESET key. | When the position of the turret is adjusted. When the clamp feed feeding starts. | |
| AL-21 | L size sewing, outside the range of data | Press the RESET key, and input the correct data again. | Under the L size sewing mode When the MACHINE READY key is pressed | 35 to 180 mm |
| AL-26 | Lockstitch pitch, outside the range of data | Press the RESET key, and input the correct data again. | When the MACHINE READY key is pressed | 2.0 to 3.4 mm |
| AL-27 | Condensation pitch, outside the range of data | Press the RESET key, and input the correct data again. | When the MACHINE READY key is pressed | 0.5 to 1.5 mm |
| AL-28 | Back tack pitch, outside the range of data | Press the RESET key, and input the correct data again. | When the MACHINE READY key is pressed | 1.0 mm to the lockstitch pitch |
| AL-29 | Data on right flap concealed stitching at the sewing start is outside the range of data | Press the RESET key, and input the correct data again. | When the MACHINE READY key is pressed | |
| AL-30 | Data on right flap concealed stitching at the sewing end is outside the range of data | Press the RESET key, and input the correct data again. | When the MACHINE READY key is pressed | |
| AL-31 | Center knife at the sewing start, outside the range of data | Press the RESET key, and input the correct data again. | When the MACHINE READY key is pressed | 5 to 15 mm |
| AL-32 | Center knife at the sewing end, outside the range of data | Press the RESET key, and input the correct data again. | When the MACHINE READY key is pressed | 7 to 15 mm |
| AL-34 | Data on left flap concealed stitching at the sewing start is outside the range of data | Press the RESET key, and input the correct data again. | When the MACHINE READY key is pressed | |
| AL-35 | Data on left flap concealed stitching at the sewing end is outside the range of data | Press the RESET key, and input the correct data again. | When the MACHINE READY key is pressed | |
| AL-36 | Corner knife cutting depth at the sewing start, outside the range of data | Press the RESET key, and input the correct data again. | When the MACHINE READY key is pressed. | 0 to 10.0 mm. |
| AL-37 | Corner knife cutting depth at the sewing end, outside the range of data | Press the RESET key, and input the correct data again. | When the MACHINE READY key is pressed. | 0 to 10.0 mm. |
| AL-40 | Data on the flap forced stop is outside the data setting range. | Press the RESET key, and input the correct data again. | When the MACHINE READY key is pressed. | 0 to 10 mm |

| Alarm code | Description | Corrective measures | Time of detection | Remarks |
|------------|---|--|---|---|
| AL-41 | Error in setting the stacker | Press the RESET key, and input the correct data again. | When the MACHINE READY key is pressed. | |
| AL-43 | Error in setting the gauge size | Set the gauge properly again. | When the MACHINE READY key is pressed. | |
| AL-44 | RAM error check | Turn OFF the power to the machine, then return it ON again. | | It is necessary to check the CPU circuit board. (This type of error will not occur in ordinary sewing works.) |
| AL-45 | Error of the sensors to detect the front end and the rear end of the clamp foot travel | Press the RESET key, then press the MACHINE READY key again. | When the clamp foot travels to its front/rear end. | |
| AL-49 | Error in upper detection of the needle thread trimmer | Check the needle thread trimmer upper detection sensor, and press the RESET key. | When the MACHINE READY key is pressed. | |
| AL-63 | Outside the range of number of stitches of back tack at the sewing start | Press the RESET key, and input the correct data again. | When the MACHINE READY key is pressed. | 3 to 19 |
| AL-64 | Outside the range of number of stitches of back tack at the sewing end | Press the RESET key, and input the correct data again. | When the MACHINE READY key is pressed. | 3 to 19 |
| AL-70 | Sewing machine motor is defective. Synchronizer TG is defective. | Check the sewing machine motor. Check the synchronizer. | When the power to the sewing machine is turned ON, or the sewing machine starts sewing. | Turn OFF the power to the machine. |
| AL-71 | Needle-up/needle-down signal of the synchronizer is not detected. | Check the synchronizer. | When the power to the sewing machine is turned ON, or the sewing machine starts sewing. | Turn OFF the power to the machine. |
| AL-72 | Sewing machine rotates in the reverse direction. | Change round the power connector of the motor. | When the sewing machine starts sewing. | Turn OFF the power to the machine. |
| AL-75 | Error in setting the sewing speed of the machine under the high speed mode | Press the RESET key, and input the correct data again. | When the MACHINE READY key is pressed or under the sewing machine operates independently. | 1000 - 2500 rpm |
| AL-76 | Error in setting the sewing speed of the machine under the low speed mode | Press the RESET key, and input the correct data again. | When the MACHINE READY key is pressed. When the sewing machine operates independently. | 500 - 1500 rpm 500 - 2500 rpm |
| AL-77 | Error in setting the time at which the intermittent operation of the sewing machine is turned ON under the sewing machine independent operation mode. | Press the RESET key, and input the correct data again. | When the sewing machine operates independently. | 1.00 - 9.99 sec. |
| AL-78 | Error in setting the time at which the intermittent operation of the sewing machine is turned OFF under the sewing machine independent operation mode | Press the RESET key, and input the correct data again. | When the sewing machine operates independently. | 1.00 - 9.99 sec. |

VII. LIST OF CHECK CODES

In the series of operation of the APW, the machine waits for a change in the relevant sensor state and proceeds to the next step of operation. If any of the sensors does not change its state for a certain period of time, one of the following indications will be given on the panel. So, check the related sensor.



WARNING:

To protect against possible accidents due to abrupt start of the machine, firstly make sure that you have placed neither your hands, fingers, face nor any tool in moving parts of the main unit of the machine, then check the sensors.

| Code | Description | Corrective measures | Time of detection | Remarks |
|-------|---|---|---|---------|
| CH-02 | Servomotor positioning signal is not detected. | Check the mechanical components to move the clamp foot. Check the servomotor, and servomotor driver. | When the clamp foot travels When an alarm is reset | |
| CH-11 | Binder positioning signal is not detected. | Check the binder sensor. | When the binder actuates | |
| CH-18 | Darts stretcher positioning signal is not detected. | Check the darts stretcher sensor. | When the darts stretcher actuates | |

