

JUKI®

**Computer-controlled Cycle Machine
with Input Function**

AMS-210D

INSTRUCTION MANUAL

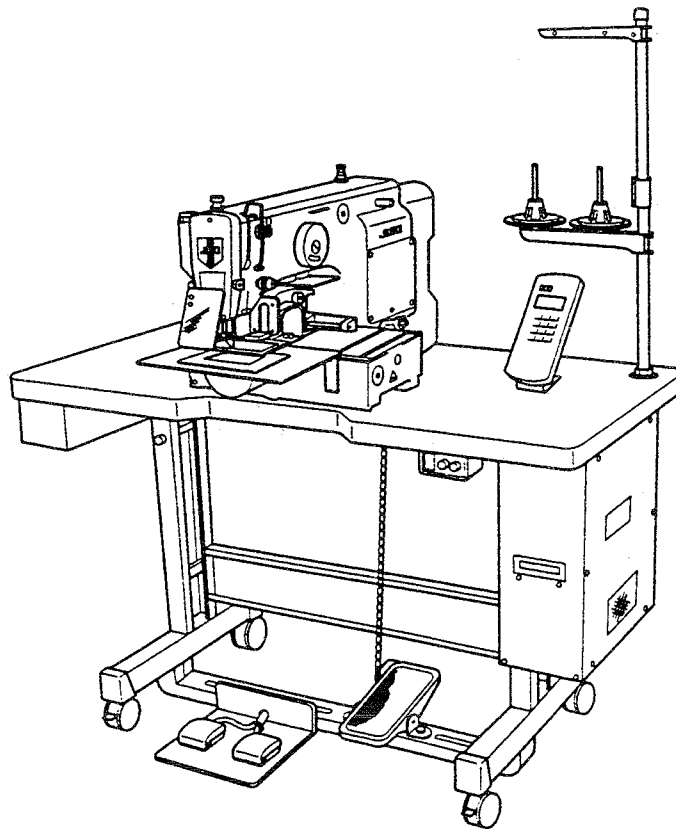

NOTE : Read safety instructions carefully and understand them
before using your AMS-210D.
Retain this Instruction Manual for future reference.

No.00
29288800

IMPORTANT SAFETY INSTRUCTIONS

To get the most out of the many functions of this machine and operate it in safety, it is necessary to use this machine correctly.

Please read this Instruction Manual carefully before use. We hope you will enjoy the use of your machine for a long time. Please remember to keep this manual in a safe place.

1. Observe the basic safety measures, including, but not limited to the following ones, whenever you use the machine.
2. Read all the instructions, including, but not limited to this Instruction Manual before you use the machine. In addition, keep this *Instruction Manual* so that you may read it at anytime when necessary.
3. Use the machine after it has been ascertained that it conforms with safety rules/standards valid in your country.
4. All safety devices must be in position when the machine is ready for work or in operation. The operation without the specified safety devices is not allowed.
5. This machine shall be operated by appropriately-trained operators.
6. For your personal protection, we recommend that you wear safety glasses.
7. For the following, turn off the power switch or disconnect the power plug of the machine from the receptacle.
 - 7-1 For threading needle(s), looper, spreader etc. and replacing bobbin.
 - 7-2 For replacing part(s) of needle, presser foot, throat plate, looper, spreader, feed dog, needle guard, folder, cloth guide etc.
 - 7-3 For repair work.
 - 7-4 When leaving the working place or when the working place is unattended.
 - 7-5 When using clutch motors without applying brake, it has to be waited until the motor stopped totally.
8. If you should allow oil, grease, etc. used with the machine and devices to come in contact with your eyes or skin or swallow any of such liquid by mistake, immediately wash the contacted areas and consult a medical doctor.

9. Tampering with the live parts and devices, regardless of whether the machine is powered, is prohibited.
10. Repair, remodeling and adjustment works must only be done by appropriately trained technicians or specially skilled personnel. Only spare parts designated by JUKI can be used for repairs.
11. General maintenance and inspection works have to be done by appropriately trained personnel.
12. Repair and maintenance works of electrical components shall be conducted by qualified electric technicians or under the audit and guidance of specially skilled personnel.

Whenever you find a failure of any of electrical components, immediately stop the machine.
13. Before making repair and maintenance works on the machine equipped with pneumatic parts such as an air cylinder, the air compressor has to be detached from the machine and the compressed air supply has to be cut off. Existing residual air pressure after disconnecting the air compressor from the machine has to be expelled. Exceptions to this are only adjustments and performance checks done by appropriately trained technicians or specially skilled personnel.
14. Periodically clean the machine throughout the period of use.

15. Grounding the machine is always necessary for the normal operation of the machine. The machine has to be operated in an environment that is free from strong noise sources such as high-frequency welder.
16. An appropriate power plug has to be attached to the machine by electric technicians. Power plug has to be connected to a grounded receptacle.

17. The machine is only allowed to be used for the purpose intended. Other used are not allowed.
18. Remodel or modify the machine in accordance with the safety rules/standards while taking all the effective safety measures. JUKI assumes no responsibility for damage caused by remodeling or modification of the machine.

19. Warning hints are marked with the two shown symbols.



Danger of injury to operator or service staff



Items requiring special attention

FOR SAFE OPERATION



1. To avoid electrical shock hazards, neither open the cover of the electrical box for the motor nor touch the components mounted inside the electrical box.



1. So as to prevent possible accidents caused by abrupt start of the sewing machine, depress the starting switch after ascertaining that there is no interfering thing under the needle when winding the bobbin thread.
2. So as to prevent possible accidents caused by abrupt start of the sewing machine, never place your fingers under the feeding frame since the feeding frame automatically comes down when the pattern is changed, the needle threading switch is ON, the bobbin thread winding switch is ON or the feeding frame switch is ON.
During operation, be careful not to allow your fingers to come close to the feeding frame.

CONTENTS

I . SPECIFICATIONS	1	VII. MAINTENANCE	18
II . CONFIGURATION	2	1. Adjusting the height of the needle bar (Changing the length of the needle)	18
1. Names of main unit	2	2. Adjusting the needle-to-shuttle relation ...	18
2. Names of the switchws for the sewing machine operation	3	3. Adjusting the height of the feeding frame	19
3. Names of display indications	3	4. Adjusting the vertical stroke of the intermediate presser	20
III. INSTALLATION	4	5. Adjusting the moving knife and counter knife	20
IV. OPERATION OF THE SEWING MACHINE	8	6. Thread breakage detector disk	21
1. Lubrication	8	7. Cleaning the filter	21
2. Attaching the needle	9	8. Draining waste oil	21
3. Threading the machine head	9	9. Replacing the fuse	22
4. Installing and removing the bobbin case ..	10	VIII. HOW TO USE THE MEMORY SWITCH	23
5. Installing the bobbin	10	1. Starting the memory switch	23
6. Adjusting the thread tension	10	2. Example of the memory switch setting	23
7. Height of the intermediate presser	11	3. Basis operation	24
V. OPERATION OF THE SEWING MACHINE (BASIC)	12	IX. INPUT MODE	26
1. Reading a sewing pattern data in the sewing machine	12	1. Names of the switches for input mode	26
2. Checkinh the contour of a sewing pattern	12	2. Operation of input mode	27
3. Sewing	13	3. Example 1 of pattern input (Disk format) ..	28
4. Change to the other sewing pattern	13	4. Example 2 of pattern input	29
5. Temporarily stopping the sewing machine	13	5. Example 3 of pattern input	32
6. Winding the bobbin thread	14	6. Example of the change of sewing speed ..	35
VI. OPERATION OF THE SEWING MACHINE (ADVANCED)	15	7. Example 4 of pattern input (Automatic back tack)	37
1. Performing sewing by means of the “bobbin thread counting function”	15	8. Example 5 of pattern input (Condensation stitching)	40
2. Performing sewing be means of “Pattern enlarging / reducing function”	15	9. Example 6 of pattern input (Double-stitch sewing)	43
3. If a workpiece cannot be set on the sewing machine because of the interruption by the needle point	16	10. Example 7 of pattern input (Overlapping stitching)	46
4. Table of error indication	16	11. Table of the function No. of the input mode	49
5. Cautions in operation	17	X. OPTIONAL	52
		1. Table of Needle hole guide	52
		2. Silicon oil tank	52
		3. Connection cord of PK-47	52

I . SPECIFICATIONS

- | | |
|---|---|
| 1) Sewing area | : X (lateral) direction 130 mm Y (longitudinal) direction 60 mm |
| 2) Max. sewing speed | : 2,500 s.p.m. (when sewing pitch is 3 mm or less) |
| 3) Stich length | : 0.1 to 12.7 mm (adjustable in 0.1 mm steps) |
| 4) Feed motion of feeding frame | : Intermittent feed (2-shaft drive by stepping motor) |
| 5) Needle bar stroke | : 41.2 mm |
| 6) Needle | : DP x 5, DP x 17 |
| 7) Lift of feeding frame | : 25 mm (standard) Max. 30mm |
| 8) Intermediate presser stroke | : 4 mm (standard) (0.5 to 10 mm) |
| 9) Lift of intermediate presser | : 20 mm |
| 10) Shuttle | : Double-capacity semi-rotary hook (self-lubricated) |
| 11) Lubricating oil | : New Defrix Oil No. 2 (supplied by oiler) |
| 12) Memory medium | : 3.5 inch micro floppy disk (2DD, 2HD)
Memory pattern : 44 to 691 pattern / cassette |
| 13) Temporary stop facility | : Used to stop machine operation during a stitching cycle. |
| 14) Enlarging / Reducing facility | : Allows a pattern to be enlarged or reduced on the X axis and Y axis independently when sewing a pattern.
Scale : 0.01 to 4 times (0.001 steps) |
| 15) Enlarging / Reducing method | : Pattern enlargement / reduction can be done by increasing / decreasing either stitch length or the number of stitches. |
| 16) Max. sewing speed limitation | : The maximum sewing speed can be set limited to any value within a range of 200 to 2,500 s.p.m., using the external control knob. |
| 17) Pattern selection | : 1 to 999 patterns can be selected by specifying the desired pattern Nos. |
| 18) Bobbin thread counter | : Tells the time to replace the bobbin. |
| 19) Memory back-up | : In case of a power interruption, the pattern being used will automatically be stored in memory so that the interrupted sewing cycle may be resumed simply by pressing the Set Ready switch after the power is restored. |
| 20) 2nd origin setting facility | : Using jog keys, a 2nd origin (needle position after a sewing cycle) can be set in the desired position within the sewing area. The set 2nd origin is also stored in memory. |
| 21) Needle-up stop facility | : When the needle does not stop in its upper position, the needle can be brought up to the upper position by turning again the needle threading switch. |
| 22) Sewing machine motor | : 400W servo-motor |
| 23) Dimensions | : 1,200 mm (W) x 710 mm (L) x 1,200 mm (H)
(Excluding thread stand) |
| 24) Gross weight | : 120 kgs |
| 25) Power consumption | : 600 VA |
| 26) Operating temperature range | : 5°C to 40°C |
| 27) Operating humidity range | : 20% to 80% (No dew condensation) |
| 28) Line voltage | : Rated voltage $\pm 10\%$ 50 / 60 Hz |
| 29) Air pressure used | : 0.5 to 0.55 MPa (5 to 5.5 kgf / cm ²) |
| 30) Air consumption | : 1.8 ℓ / min |
| 31) Needle highest position stop facility | : After the completion of sewing, the needle can be brought up to its highest position. |

} For pneumatic type only.

II . CONFIGURATION

1. Names of main unit

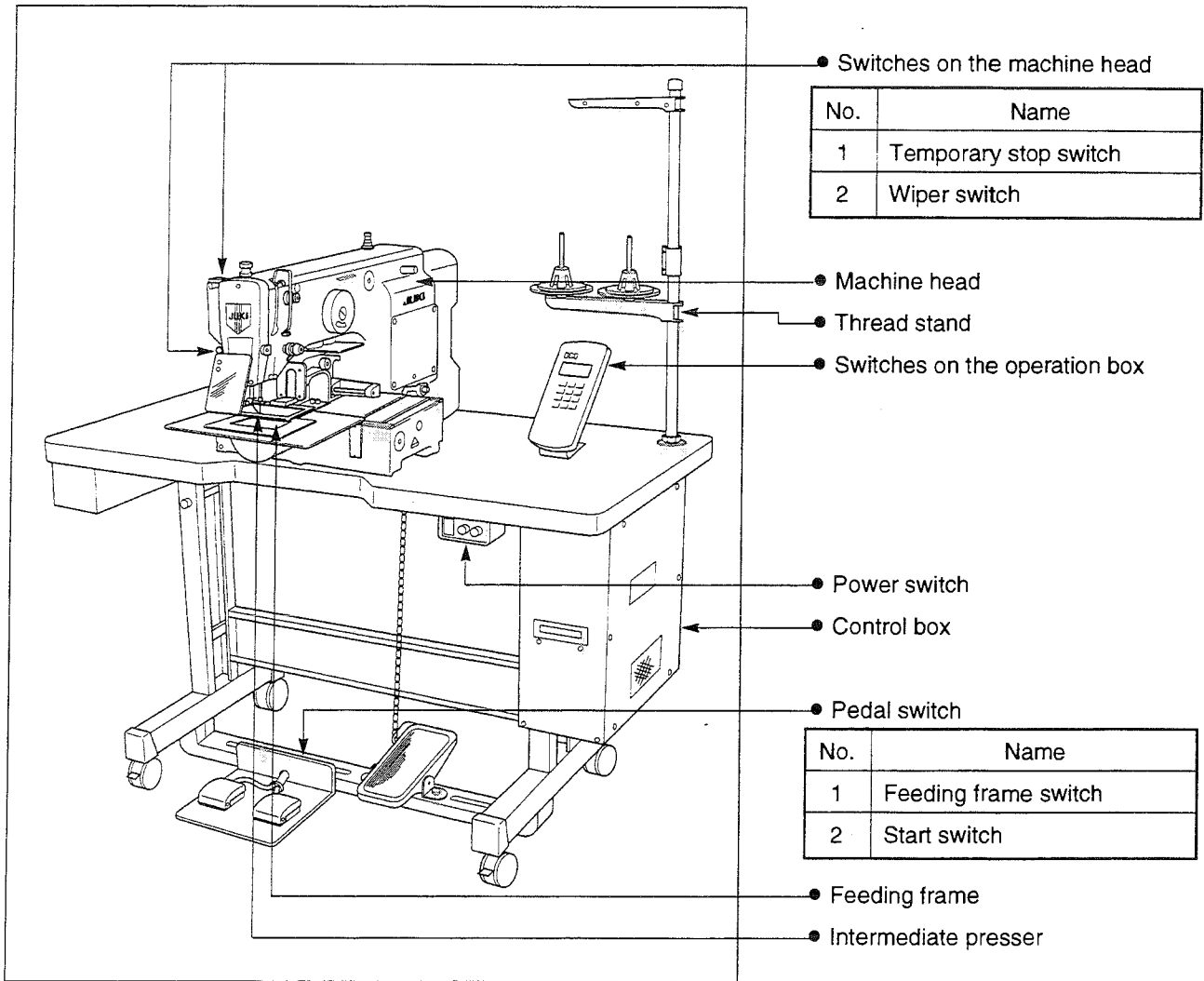

Air regulator (for pneumatic type only)

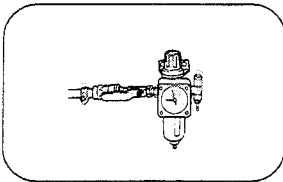

2. Names of the switchs for the sewing machine operation

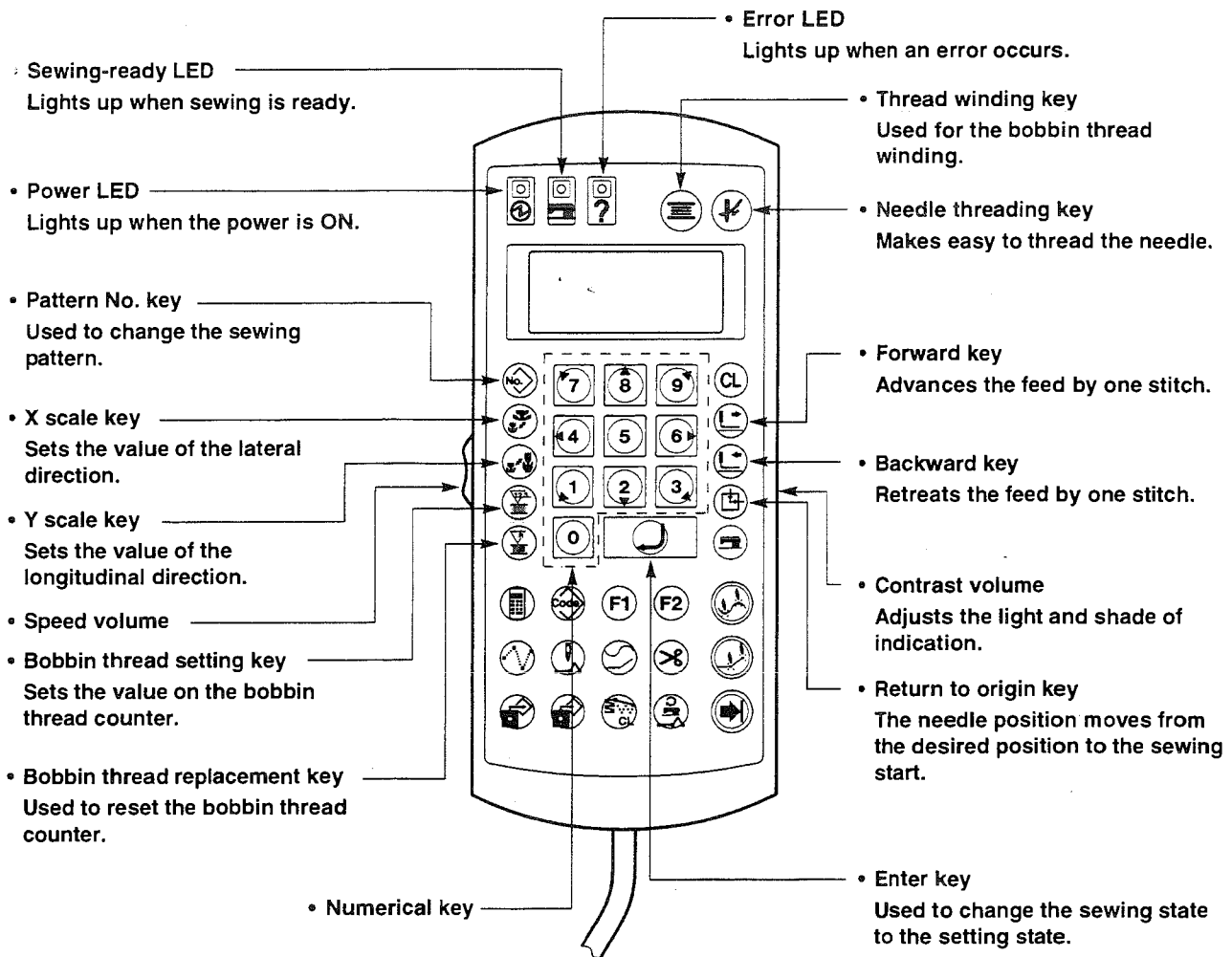

3. Names of display indications

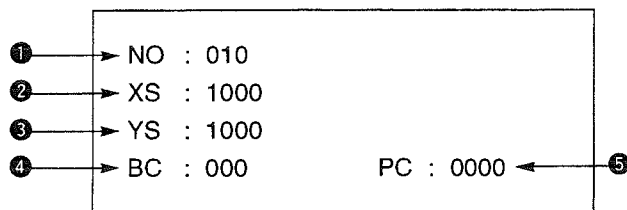

- ① Indication of Pattern No. : Can be changed by No. key and Numerical key.
- ② , ③ Enlargement / reduction indication : Indication of 1000 shows 100%.
 - X (Y) – : 100% fixed.
 - X (Y) P : Enlargement / reduction can be made by increasing / decreasing the pitch.
 - X (Y) S : Enlargement / reduction can be made by increasing / decreasing the number of stitches.
- ④ Bobbin thread counter : Set by [Bobbin thread setting] key and numerical key.
- ⑤ Production counter : By pressing [Clear] key, push [Bobbin thread replacement] key to clear the counter to 0000.

III . INSTALLATION



WARNING :

To prevent possible accidents caused by the fall of the sewing machine, perform the work by two persons or more when the machine is moved.

- (1) Set cushion rubbers supplied as accessory on the table.

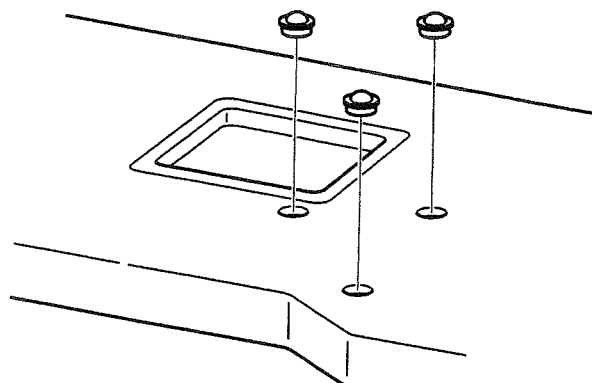

- (2) Fit the holes of hinges **A** to the holes of table and fix as shown in the figure.

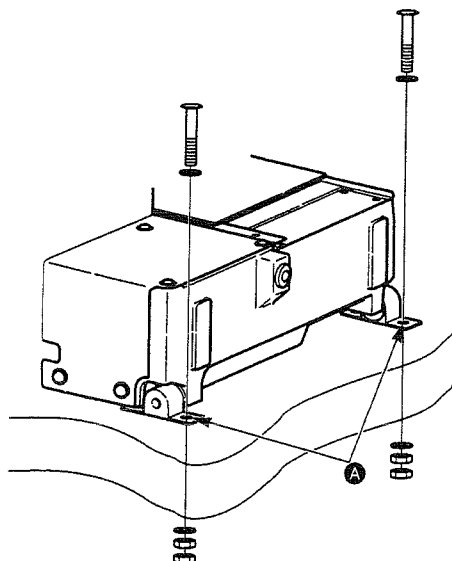

- (3) Lift the sewing machine head, fit the holes of hinges **B** to the holes of table and fix as shown in the figure.

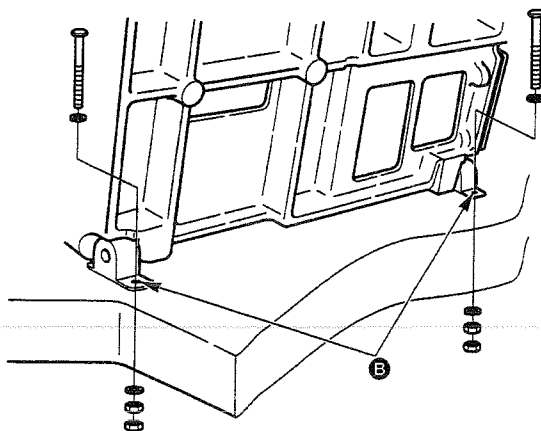

(4) Connect the cords extending from control box to the cords coming from the machine head as shown in the figure.

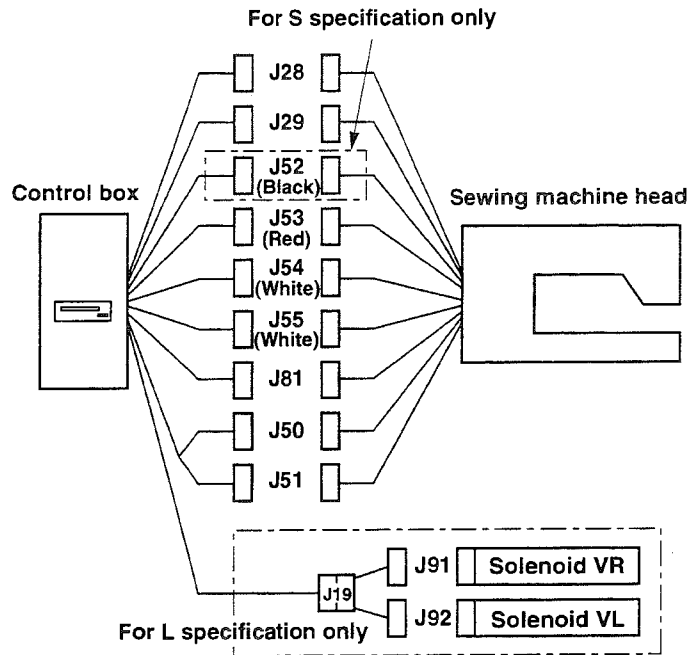

(5) Attaching the motor cover

Attach motor cover with screws as shown in the figure below.

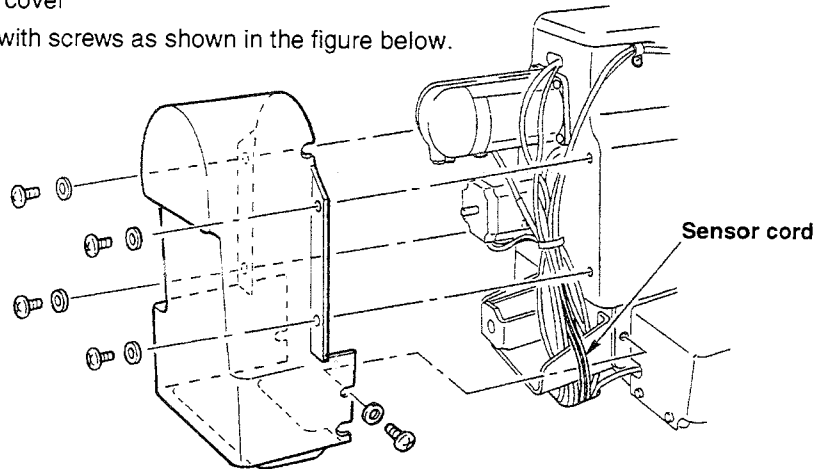

(6) Attaching the eye protection cover



WARNING :

Be sure to attach this cover to protect the eyes from the disperse of needle breakage.

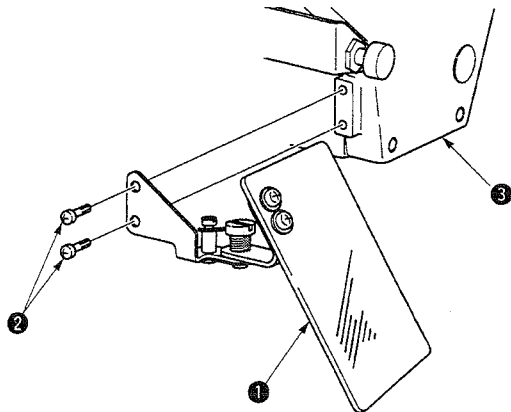

Use eye protection cover ① after securely attaching it on face plate cover ③ with screw ② .

(7) In case of pneumatic unit, connect the air hose.

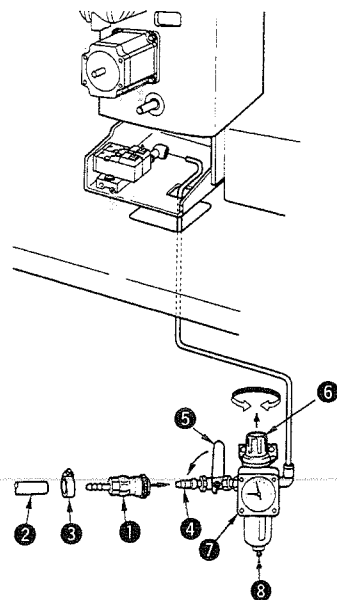

Open air cock ⑤ , pull up the knob ⑥ of air regulator and turn it to adjust so that the air pressure gauge ⑦ indicates 0.5 to 0.55 MPa (5 to 5.5 kgf / cm²). Then press the knob to maintain the pressure value.

* Air will be blown out if you close air cock ⑤ and push the button ⑧ .

(8) Attaching the pedal chain (For S specification only)

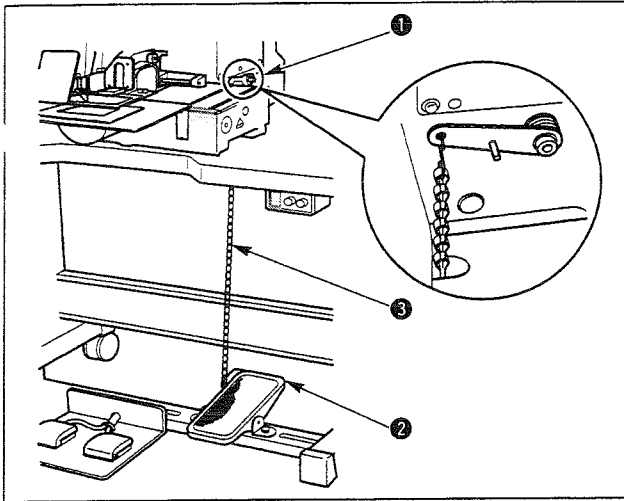

Connect the machine ① and manual pedal ② with chain ③.

(Caution)

When you tilt the machine, be sure to remove the chain.

(9) Installing the thread stand

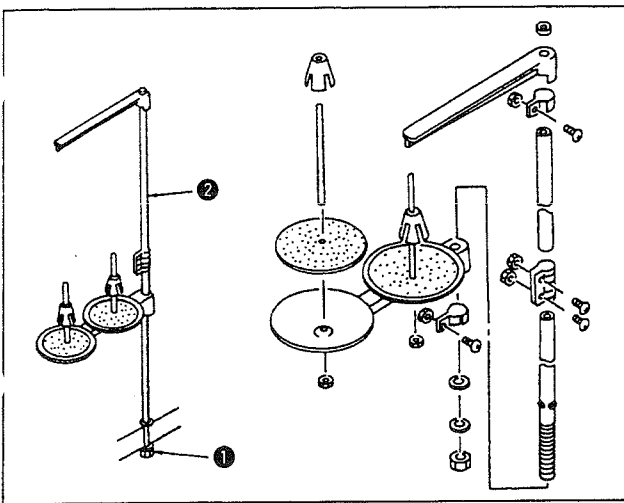

- 1) Assemble the thread stand, and put it in the hole in the top left corner of the machine table.
- 2) Tighten locknut ① to fix the thread stand.
- 3) When ceiling wiring is possible, pass the power cord through spool rest rod ②.

(10) Installing the operation box

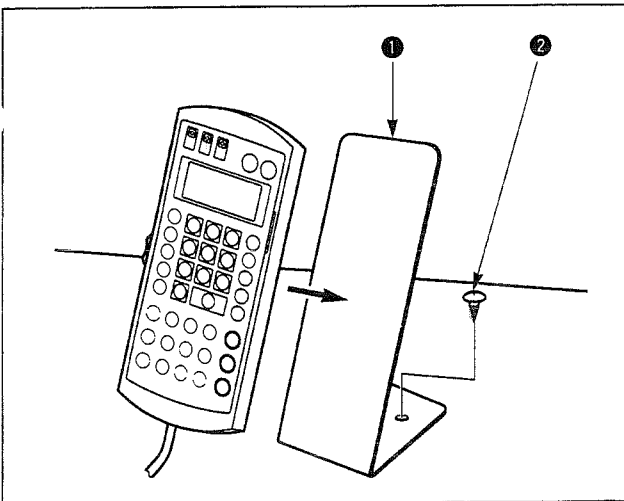

Fix operation box attaching plate ① on the table with woodscrew ②.

Remove vinyl coated on the surface of sheet.

IV . OPERATION OF THE SEWING MACHINE

1. Lubrication



WARNING :

Turn OFF the power before starting the work so as to prevent accidents caused by abrupt start of the sewing machine.

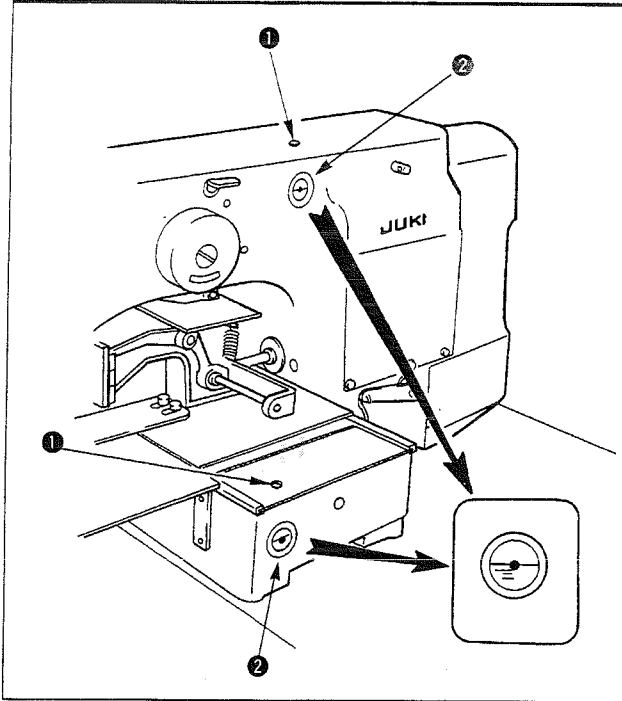

- 1) Fill oil from oil hole ① on the machine head up to the red mark in the center of oil gauge ② .

(Caution)

Be sure to apply oil when the machine is first installed, or when it is run after a long period of disuse.

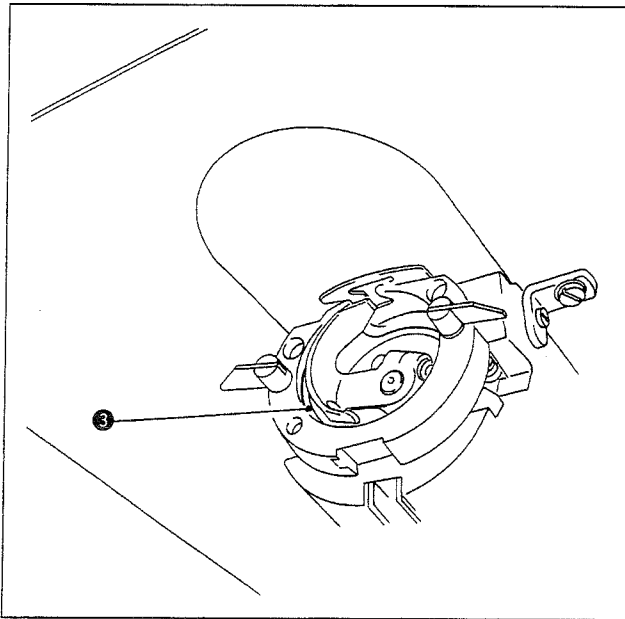

- 2) Apply one drop of oil to the hook race ③ part to spread on it.

2. Attaching the needle



WARNING :

Turn OFF the power before starting the work so as to prevent accidents caused by abrupt start of the sewing machine.

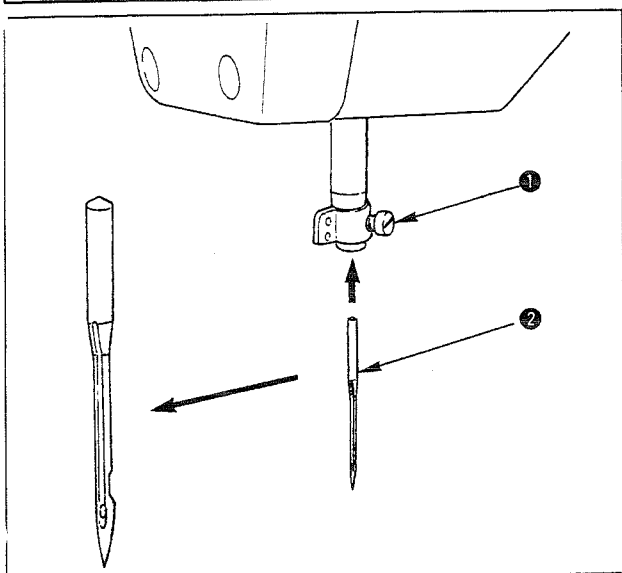

Loosen setscrew ① and hold needle ② with the long groove facing toward you. Then fully insert it into the hole in the needle bar, and tighten setscrew ① .

3. Threading the machine head



WARNING :

Turn OFF the power before starting the work so as to prevent accidents caused by abrupt start of the sewing machine.

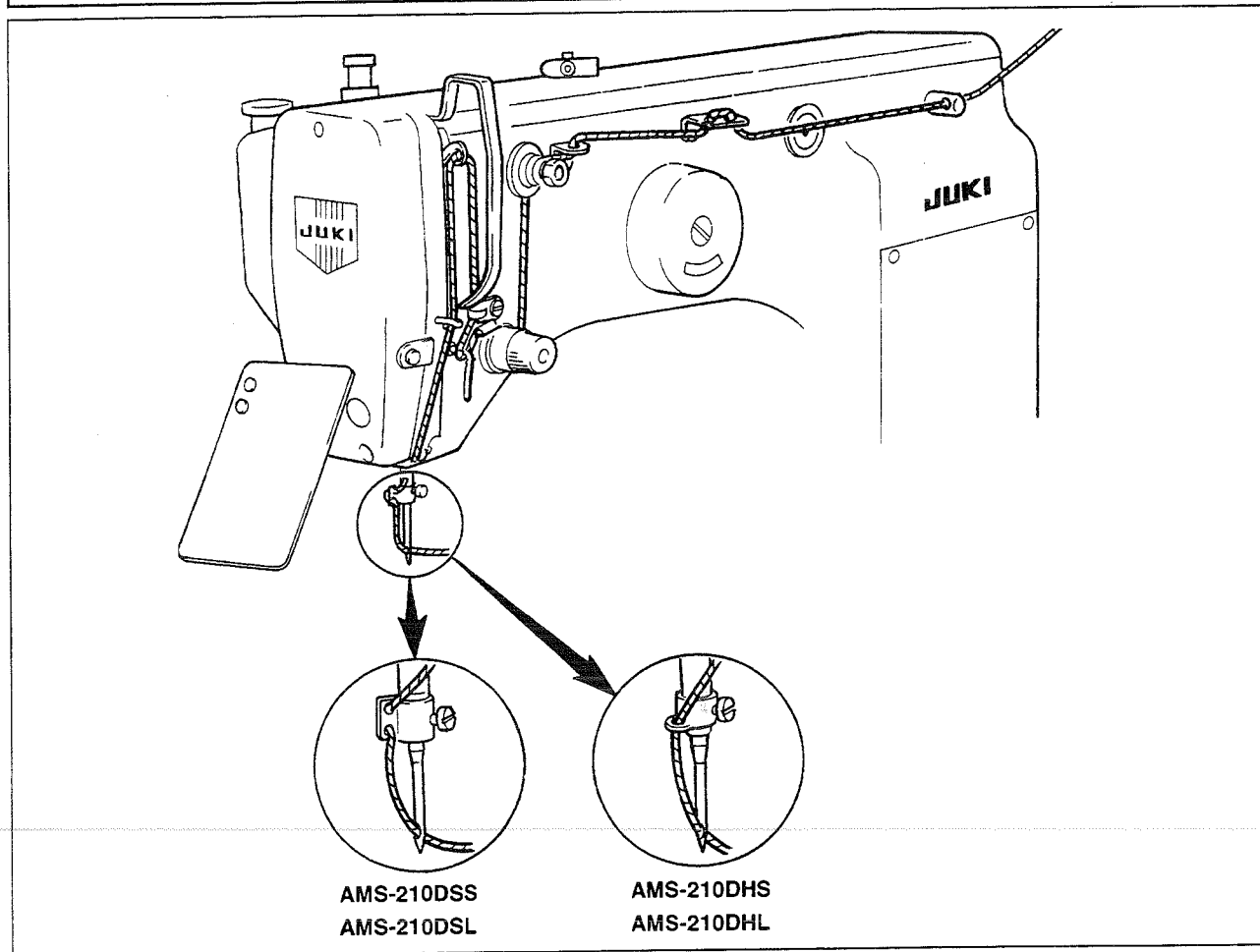

4. Installing and removing the bobbin case



WARNING :

Turn OFF the power before starting the work so as to prevent accidents caused by abrupt start of the sewing machine.

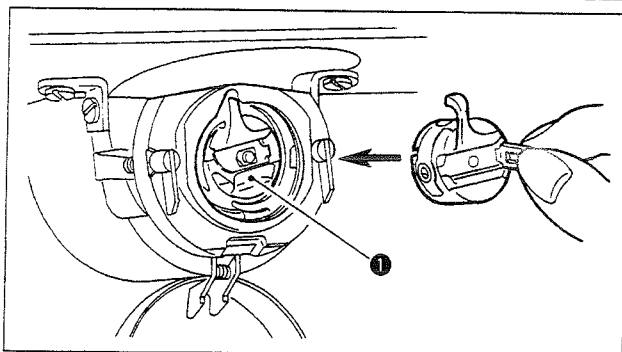

(Caution)

If bobbin case ❶ is not securely loaded in the shuttle, bobbin case ❶ may slip off during sewing.

5. Installing the bobbin

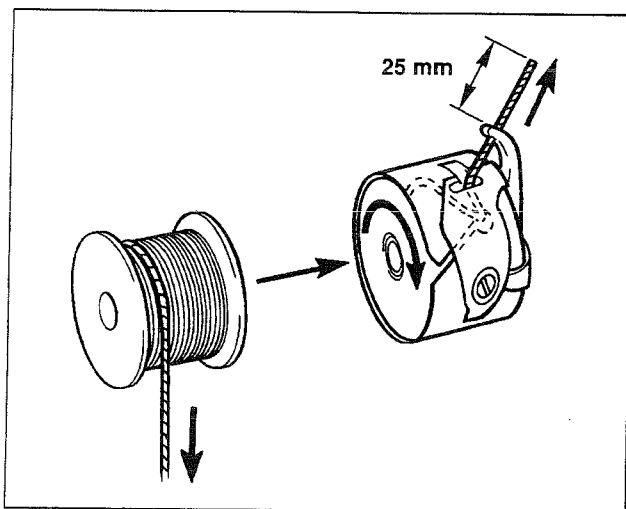

(Caution)

If the bobbin is installed in the bobbin case orienting the reverse direction, the bobbin thread pulling out will result in an inconsistent state.

6. Adjusting the thread tension

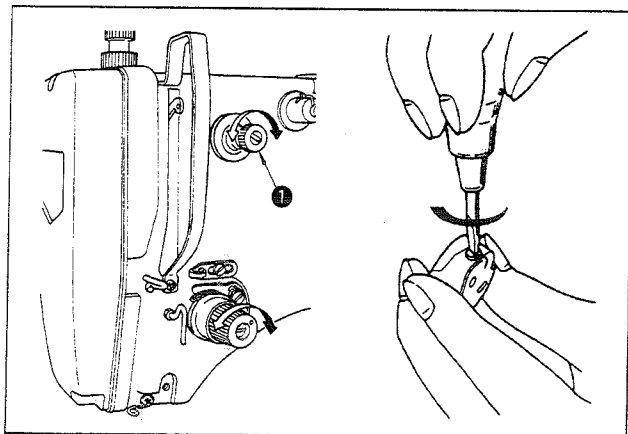

If thread tension controller No.1 ❶ is turned counterclockwise, the length of remaining thread is increased.

7. Height of the intermediate presser

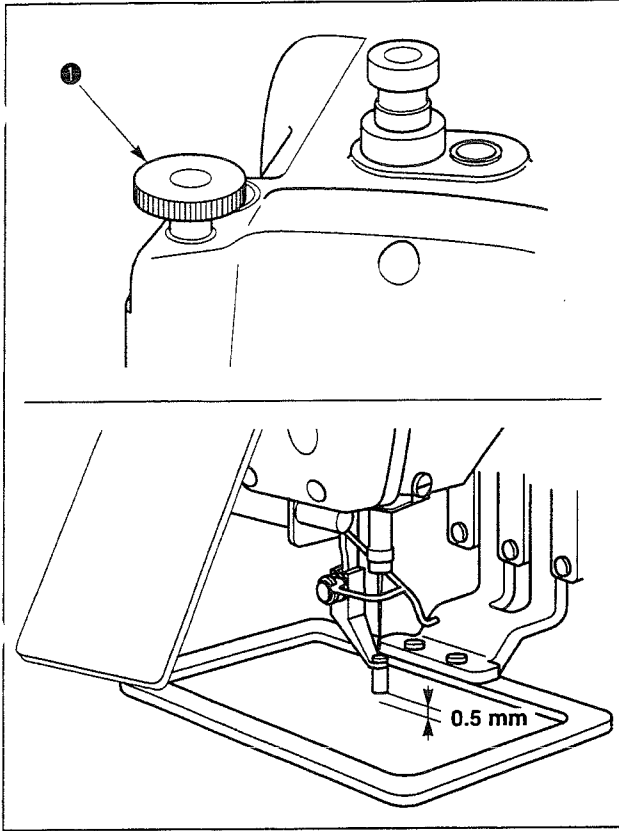



Turn handwheel, and adjust so that a clearance of 0.5 mm (thickness of the needle thread used) is provided between the bottom end of the intermediate presser and the material when the needle is brought to the lowest point of its stroke by turning the knob ①.

(The intermediate presser can be used with the material of which thickness is 5 mm or less.)

V . OPERATION OF THE SEWING MACHINE (BASIC)

* Two service patterns are included in the floppy disks supplied as accessories.

Pattern No.	Shape
500	
501	

1. Reading a sewing pattern data in the sewing machine



WARNING :

Never place your fingers or any other thing under the feeding frame as the feeding frame automatically comes down after the completion of computing a pattern.

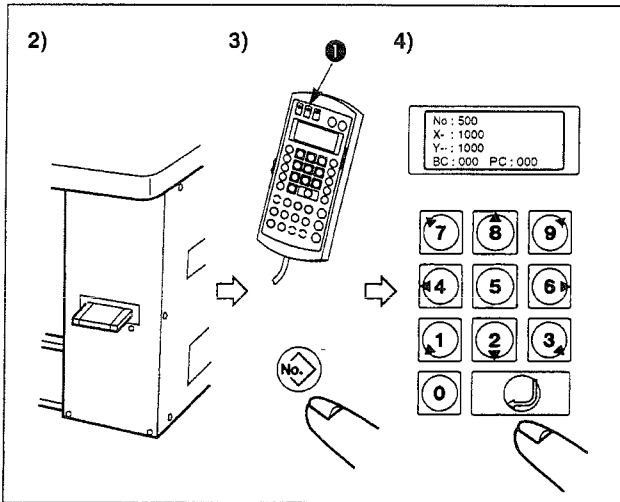

As an example, read a sewing pattern using a service pattern.

- 1) Turn ON the power switch.
- 2) Insert a floppy disk.
- 3) Push the [Pattern No.] key.
- 4) Input a pattern No. of three figure number pressing the numerical key.
Input [5][0][0] in the service pattern.
- 5) Push the [Enter] key.

When the pattern reading procedure completes, the feeding frame comes down once. Then the machine will retrieve the origin and the sewing LED  will light up. Now, it is ready to start sewing.

2. Checkinh the contour of a sewing pattern



WARNING :

If the sewing pattern extends outside the feeding frame, the needle will interfere with the feeding frame during sewing, causing dangerous troubles including needle breakage.

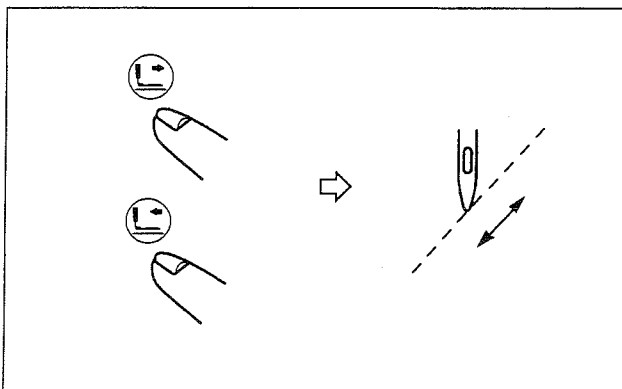

- 1) Depress the pedal switch to descend the feeding frame.
- 2) Every press on the [Forward] key or the [Backward] key will move the needle point by one stitch. Keeping the key held pressed, the needle will move continuously.
- 3) After you have checked the contour of the sewing pattern, press the [Return-to-origin] key. This will return the needle point to the start position and the feeding frame will go up.

If you keep pressing the [Forward] key or the [Backward] key for more than a certain time, the feed will continue even if you detach the key. Press the key again to stop the feed.

3. Sewing

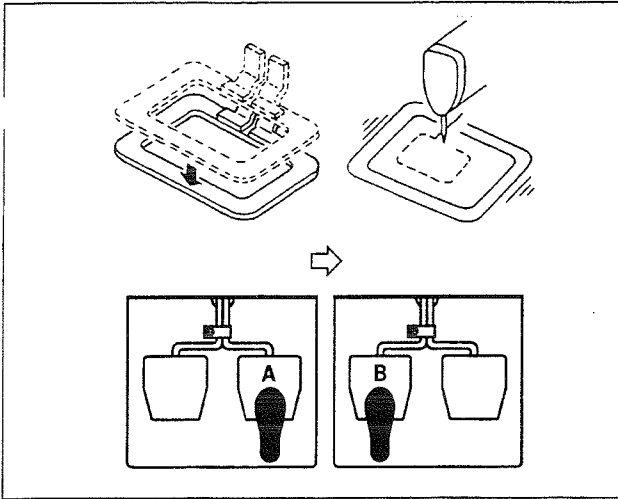

- 1) Set a workpiece on the sewing machine.
- 2) Depress the pedal switch **A**, and the feeding frame will come down. Depress it again, and the feeding frame will go up.
- 3) Depress the pedal switch **B** after the feeding frame has come down and the sewing machine will start sewing.
- 4) After the sewing machine completes sewing, the needle point will return to the start point and the feeding frame will go up.

4. Change to the other sewing pattern

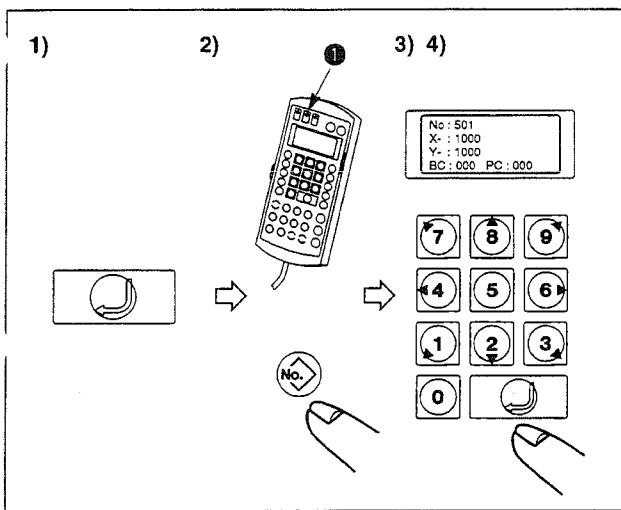

- 1) Press the [Enter] key. (the sewing LED **1** will go off.)
- 2) Press the [Pattern No.] key.
- 3) Input the [Pattern No.] key.
In case of the service pattern, input [5][0][1].
- 4) Press the [Enter] key. (the sewing LED **1** will light up.)
Now, the sewing is ready.

For further steps, refer to "2. Checking the contour of a sewing pattern" (Refer to the previous page).

5. Temporarily stopping the sewing machine

You can temporarily stop the sewing machine during sewing or sewing pattern shape checking procedure.

5-1. How to temporarily stop the sewing machine

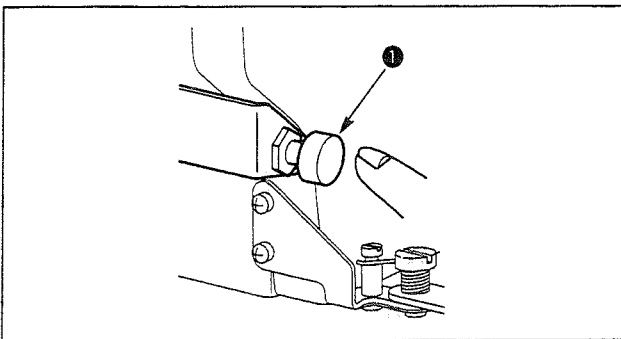

Press the temporary stop switch **1** while the sewing machine is in operation.

This will temporarily stop the sewing machine.

5-2. Returning the sewing machine to the start of sewing (Re-sewing a sewing pattern from the start)



WARNING :

The sewing machine makes a revolution and the needle goes up and comes down. So, never place your fingers or any other thing under the needle.

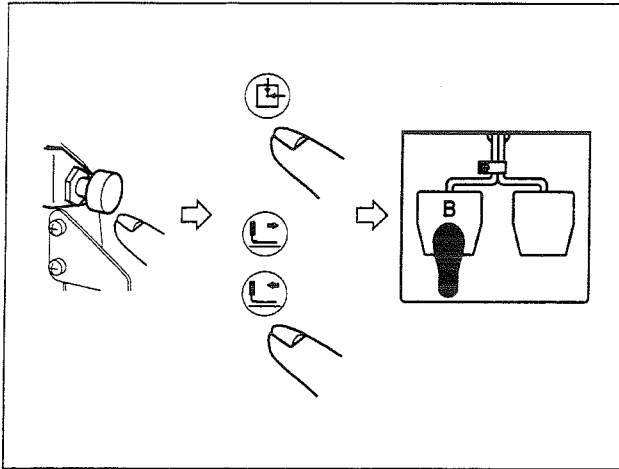

- 1) As "Stop-key is pressed" is shown on the operation panel, press again the temporary stop switch and actuate the thread trimmer.

(Caution)

If the main shaft is not in the upper resting position, ON / OFF the needle threading switch will first make the main shaft return to the upper resting position.

- 2) Pressing the [Return-to-origin] key, [Forward] key or [Backward] key will make the needle point return to the initial position.
- 3) Press the pedal switch for re-starting.

6. Winding the bobbin thread

6-1. To wind a bobbin while the sewing machine is performing sewing

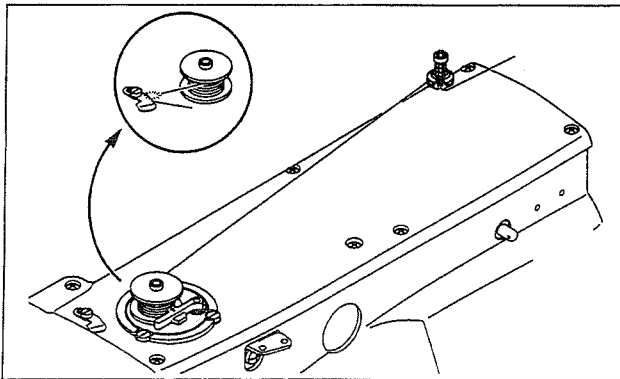

Thread the bobbin winder and wind the thread onto the bobbin as illustrated in the figure.

6-2. To wind a bobbin independently



WARNING :

While the bobbin winder winds a bobbin, the feeding frame does not move but the needle bar moves, So, do not place your fingers or any obstacle under the needle.

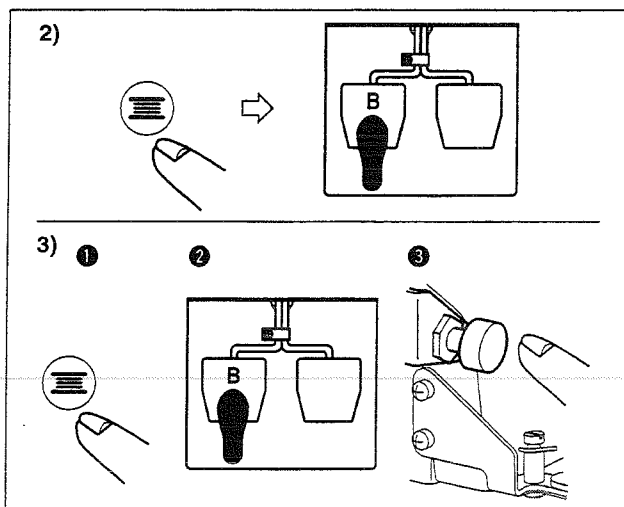

- 1) Set the bobbin as shown in the above figure.
- 2) Press the bobbin winder switch, and depress the foot switch **B**. Then, the bobbin winder will start to wind the bobbin.
- 3) The bobbin winder can be stopped by taking one of the following three procedures.
 - ① Press the bobbin winder switch.
 - ② Depress the foot switch **B**.
 - ③ Press the temporary stop switch.

VI. OPERATION OF THE SEWING MACHINE (ADVANCED)

1. Performing sewing by means of the “bobbin thread counting function”

In case a same sewing pattern is sewn in repetition, the sewing machine will stop sewing when the number of workpieces (the specified number of workpieces) that can be sewn with a bobbin is reached.

The bobbin thread counter indicates the finished number of workpieces in the two different methods. You can select either the adding method or the subtracting method.

(Refer to “VIII. How to use the memory switch”(Page 23))

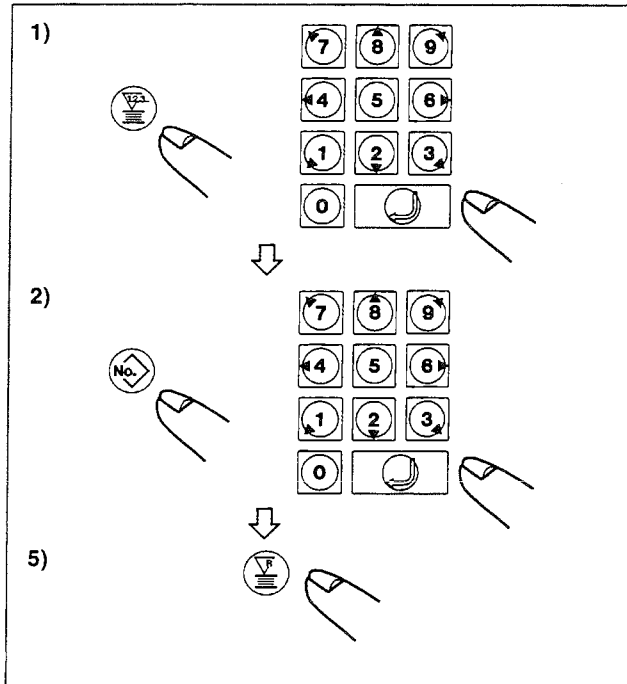

- 1) Press the [Bobbin thread counter] key.
Press the numerical key, and input the specified number of workpieces that can be sewn with a bobbin.
- 2) Insert a floppy disk into the floppy disk inserting slot.
Input a sewing pattern No. desired and press the [Enter] key.
- 3) Every time the sewing machine finishes a workpiece, counting is made by one.
- 4) When the sewing machine finishes the specified number of workpieces, the sewing machine will stop.
- 5) Replace the bobbin with a new one, and press the [Bobbin thread replacing] key.
- 6) Repeat the steps of procedure from step 3).

(Caution)

The indication of bobbin thread counter is under the state of delivery of the memory switch :

- Adding method
- Production counter-ON

2. Performing sewing by means of “Pattern enlarging / reducing function”

(Refer the setting of pattern enlarging / reducing to “VIII. How to use the memory switch”.)

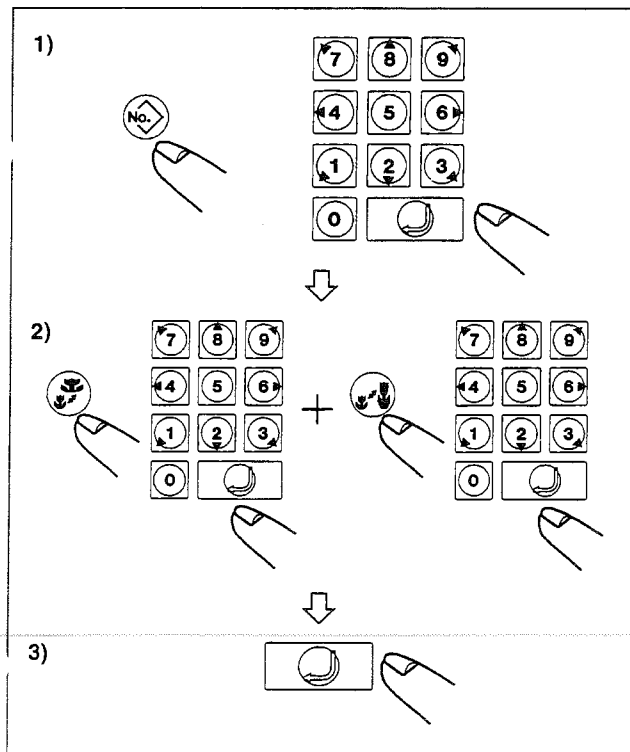

- 1) Insert a floppy disk into the floppy disk inserting slot and input a sewing pattern No. desired.
- 2) Input a scale (%) by which the sewing pattern is to be enlarged / reduced in the X or Y direction.

(Caution)

The pattern can be enlarged / reduced in the range of 1% to 400% while the size of of pattern written in the floppy disk is taken as 100%.

- 3) Press the [Enter] key, and the specified size of the sewing pattern will be read in the sewing machine. Then, the machine will be ready for sewing.

(Caution)

1. After the pattern is enlarged or reduced, make sure the movement whether the needle and the feeding frame interferes with each other.
2. The method of enlarging / reducing is “number of stitches increasing / reducing” under the state of delivery of the memory switch.

3. If a workpiece cannot be set on the sewing machine because of the interruption by the needle point

Normally, the feeding frame rests at the sewing start position when you set a workpiece to be sewn on the sewing machine. If you cannot easily place the workpiece on the machine since the needle point interferes with you, you can specify the position of the feeding frame as desired.

(The sewing position will remain the same.)

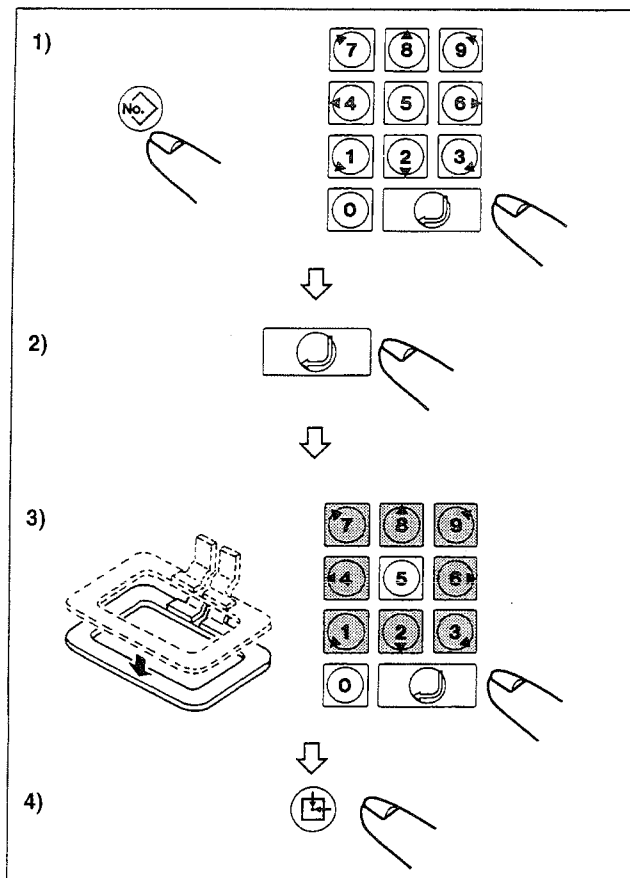

- 1) Insert a floppy disk into the slot and input a sewing pattern No. desired.
- 2) Press the [Enter] key, and the sewing machine will read the sewing pattern data from the floppy disk and the feeding frame will go up at the start position of sewing.
- 3) Depress the pedal to make the feeding frame come down. Then, press the direction key and the needle point will move.
- 4) After you have moved the needle to a position at which the needle point does not interfere with the workpiece to be set, press the return-to-origin key or depress again the pedal.

(Caution)

1. If the [Enter] key is pressed twice continuously, the turn-out point specified will be cancelled.
2. If you specify a new turn-out point, the previously specified one will be cancelled.

* If error indication is shown on the operation box while the machine is in operation, refer to "Table of error indications".

4. Table of error indication

No.	Error description	Indication
10	Pattern No. specified is not input.	No Pattern Found
11	Floppy disk is not inserted.	No Disk in Drive
20	Outside the setting range of enlarging / reducing.	Scaling Range 10 through 4000
21	Malfunction in computing or press down of the stop key.	Processing Aborted
25	Bobbin thread counter has reached the point specified.	Reset Counter
31	Air pressure for the sewing lowered.	Air Pressure Drop
32	Air pressure recovered.	Air Pressure, OK
50	Stop by means of the stop key during operation or the like.	Stopkey Accepted
51	Informing that thread trimming is not made because of the stop by means of the stop key during operation.	Stopkey Accepted Not Trimmed Yet
52	Stop by means of detecting the needle thread breakage.	Thread Broken

5. Cautions in operation

(1) Floppy disk driver

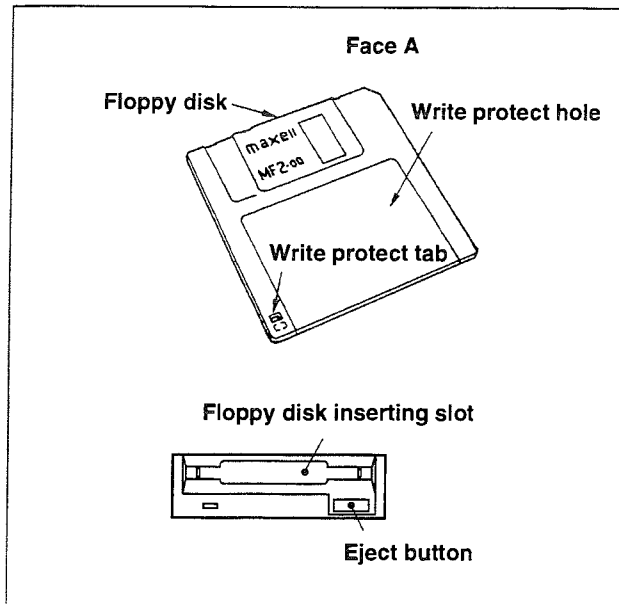

- 1) Loading the floppy disk
After turning the power switch ON, slowly insert the floppy disk, with its face A looking to the upper as observed from you, until the eject button pops out.
- 2) Unloading the floppy disk
After the reading of the floppy disk is over, press the eject button and take out the floppy disk.
- 3) Write-protect hole
When the write-protect tab is moved to open the write-protect hole, no data is allowed to be written into the disk. Use for retaining the programmed data.
For writing data into the disk, move the write-protect tab until it is exposed.

(Caution)

Never turn the power switch ON or OFF with the floppy disk mounted.

(2) Precautions in handling floppy disks

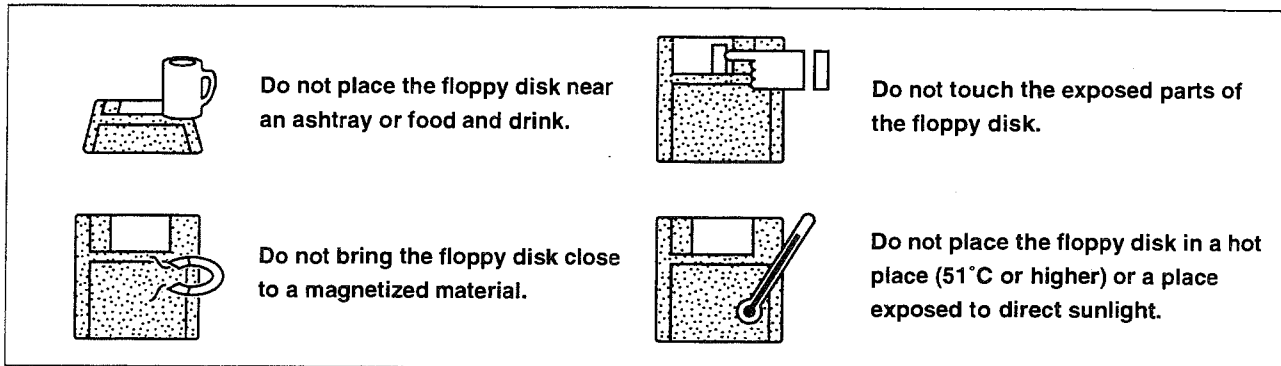

- (3) When the threader and sewing machine are switched ON, sew the desired sewing pattern with the thread tension disk closed. Once, you have completed the thread trimming, the thread tension disk will open.

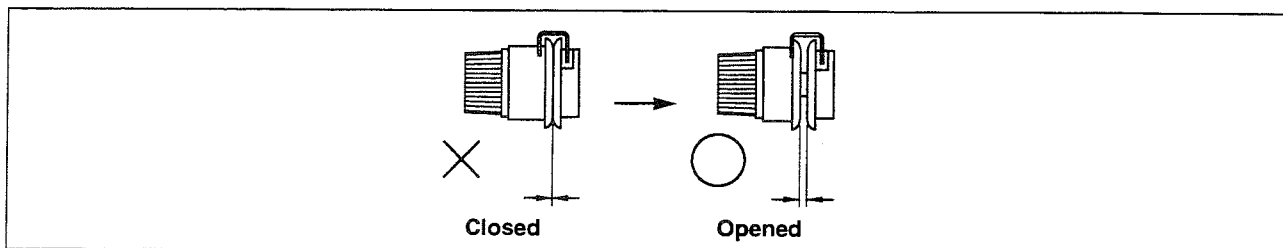

- (4) Before sewing a new pattern or using a new feeding frame (small), be sure to check the contour of the pattern for the relation between the feeding frame and the pattern.
- (5) Be sure to check for a cause of trouble and take a proper corrective measure when the error indicator lamp lights up.
- (6) Do not draw, by hand, the material being sewn during sewing. Doing so will cause the needle shift from the correct position. If the needle moves from the correct position in terms of the X / Y direction, press the [Enter] key twice. This will return the needle to the normal origin.
- (7) Insert the floppy disk in the control box only when the pattern reading is made. Take it out when the machine is normally operated.

VII . MAINTENANCE

1. Adjusting the height of the needle bar (Changing the length of the needle)



WARNING :

Turn OFF the power before starting the work so as to prevent accidents caused by abrupt start of the sewing machine.

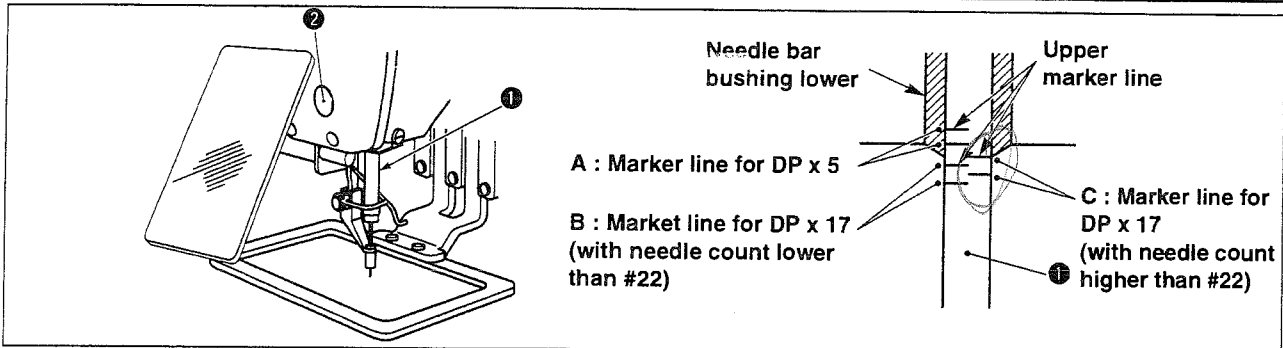

- 1) Bring needle bar ① down to the lowest position of its stroke. Loosen needle bar connection screw ② and adjust so that the upper marker line engraved on the needle bar aligns with the bottom end of the needle bar bushing lower.
- 2) As illustrated in the above figure, change the adjusting position in accordance with the needle count.

(Caution) After the adjustment, turn the pulley to check for an extra load.

2. Adjusting the needle-to-shuttle relation



WARNING :

Turn OFF the power before starting the work so as to prevent accidents caused by abrupt start of the sewing machine.

Relation between the needle and the marker lines on the needle bar

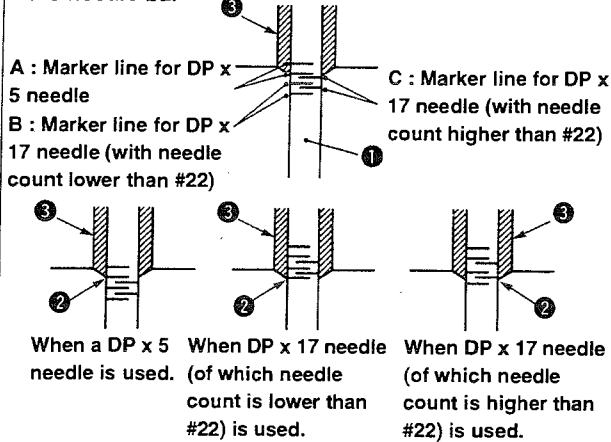

- 1) Turn handwheel by hand to ascend the needle bar ①. Adjust so that lower marker line ② on the ascending needle bar aligns with the bottom end of the needle bar bushing lower.

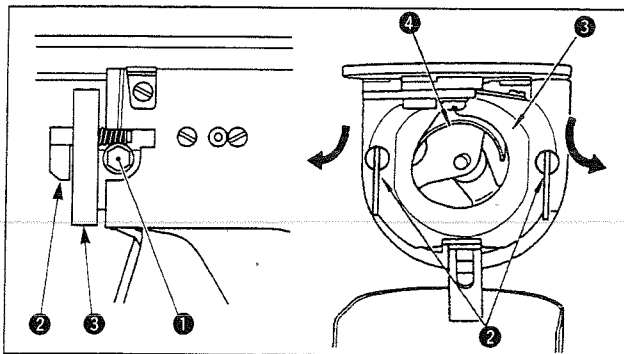

- 2) Loosen setscrew ① in the driver. Drawing bobbin case opening lever hook ② toward you, open it to the right and left until bobbin case opening lever ③ comes off.

(Caution)

At this time, be careful not to let shuttle ④ come off and fall.

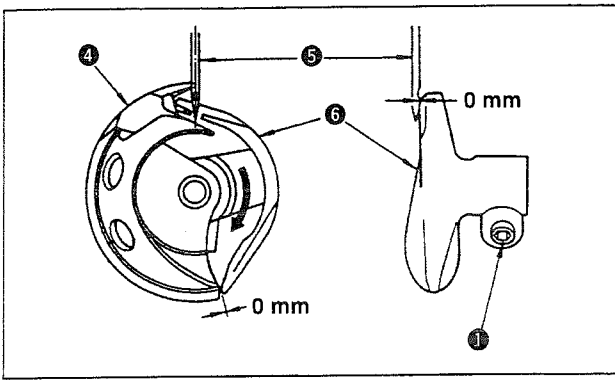

- 3) Adjust so that the point of shuttle ④ meets the center of needle ⑤, and that a clearance of 0 mm is provided between the front end face of driver ⑥ and needle as the front end face of driver receives needle to prevent the needle from being bent. Then tighten setscrew ①.

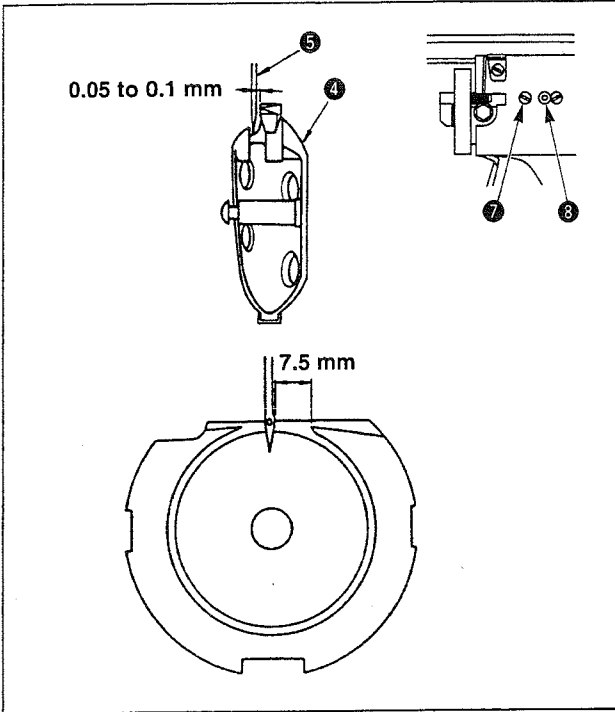

- 4) Loosen shuttle race screw ⑦, and adjust the longitudinal position of the shuttle race. To do this adjustment, turn shuttle race adjusting shaft ⑧ clockwise or counterclockwise to provide a 0.05 to 0.1 mm clearance between needle ⑤ and the blade point of shuttle ④.
- 5) After adjusting the longitudinal position of shuttle race, further adjust to provide a 7.5 mm clearance between the needle and the shuttle race. Then, tighten screw ⑦ of shuttle race.

3. Adjusting the height of the feeding frame



WARNING :

Turn OFF the power before starting the work so as to prevent accidents caused by abrupt start of the sewing machine.

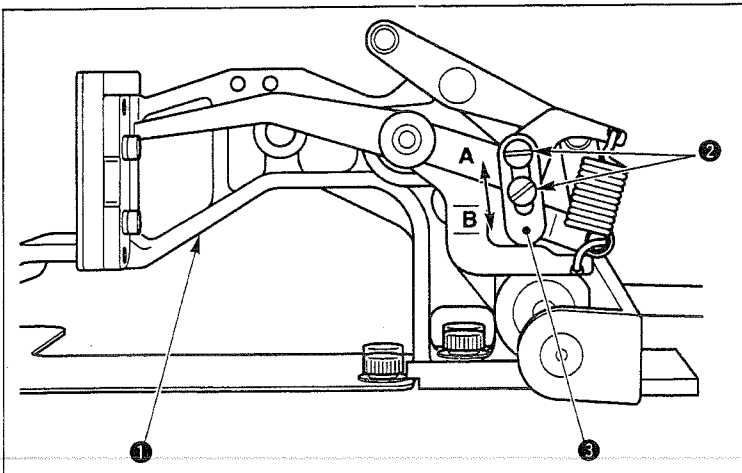

- 1) Loosen screws ② located on the right and left sides of feed bracket ①. Moving cloth presser stopper ③ to the direction B will increase the height of feeding frame.
- 2) After the adjustment of the height of the feeding frame, securely tighten the screws ②.

4. Adjusting the vertical stroke of the intermediate presser



WARNING :
Turn OFF the power before starting the work so as to prevent accidents caused by abrupt start of the sewing machine.

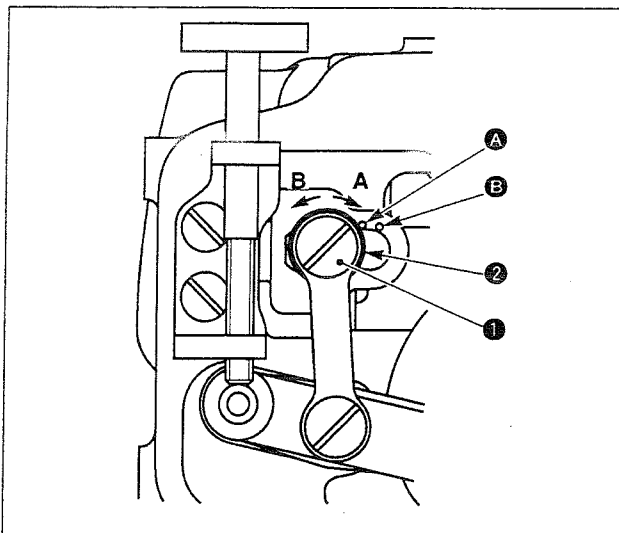

- 1) Remove face cover.
- 2) Turn handwheel to make the needle bar come down to its lowest point.
- 3) Loosen hinge screw ① and move it to the direction A to increase the stroke.
- 4) When marker dot A is aligned with the right side of the outer periphery of washer ②, the vertical stroke of the intermediate presser becomes 4 mm. And, when marker dot B is aligned with the right side of the outer periphery of the washer, it becomes 7 mm.
(The vertical stroke of the intermediate presser is factory-set to 4 mm at the time of delivery.

5. Adjusting the moving knife and counter knife



WARNING :
Turn OFF the power before starting the work so as to prevent accidents caused by abrupt start of the sewing machine.

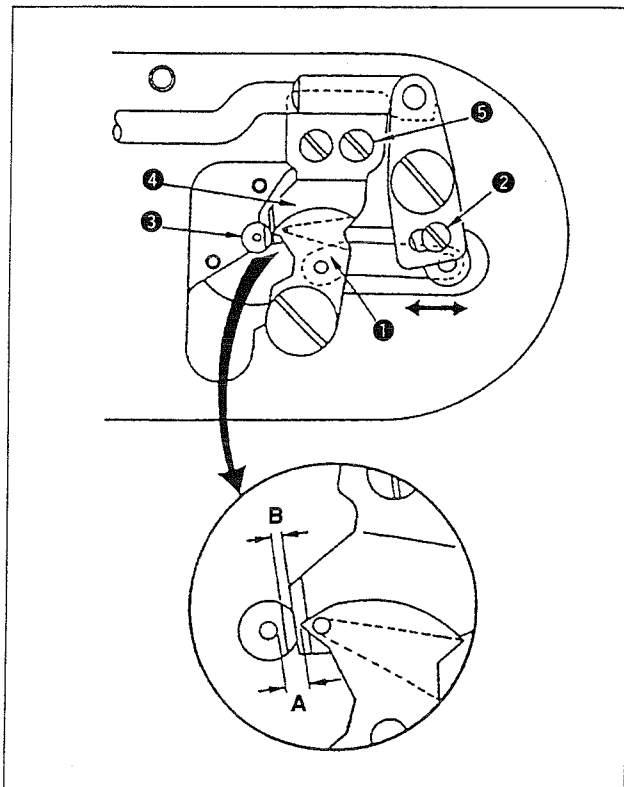

- 1) When the sewing machine stops in the upper stop position, loosen adjusting screw ② and adjust clearance A provided between the thread handling section of moving knife ① and the edge of needle eyelet.
- 2) After the adjustment, manually actuate the thread trimmer to check for proper positioning.
- 3) Loosen screw ⑤, and adjust clearance B provided between the needle hole guide ③ and the counter knife ④.

Sewing specification	Section to be adjusted	
	A	B
S	4.5 mm	0.8 mm
H	5.3 mm	0.8 mm

6. Thread breakage detector disk



WARNING :

Turn OFF the power before starting the work so as to prevent accidents caused by abrupt start of the sewing machine.

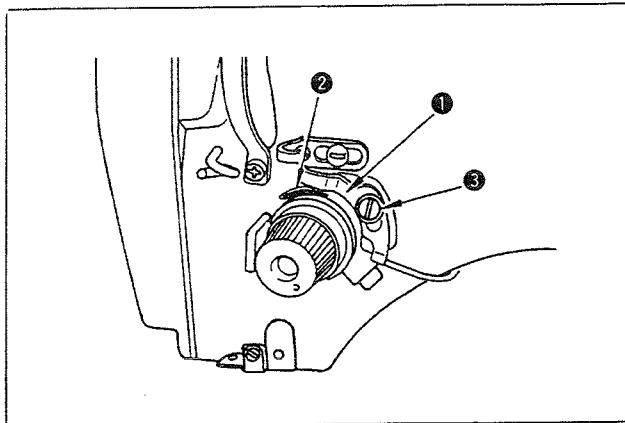

- 1) Adjust so that thread breakage detector disk ① is always in contact with thread take-up spring ② in the absence of needle thread. (Slack : approx. 0.5 mm)
- 2) Whenever the stroke of thread take-up spring ② has been changed, be sure to readjust thread breakage detector disc ①. To make this adjustment, loosen screw ③.

(Caution)

Adjust so that thread breakage detector disk ① does not touch any adjacent metallic parts other than thread take-up spring ②.

7. Cleaning the filter



WARNING :

Turn OFF the power before starting the work so as to prevent accidents caused by abrupt start of the sewing machine.

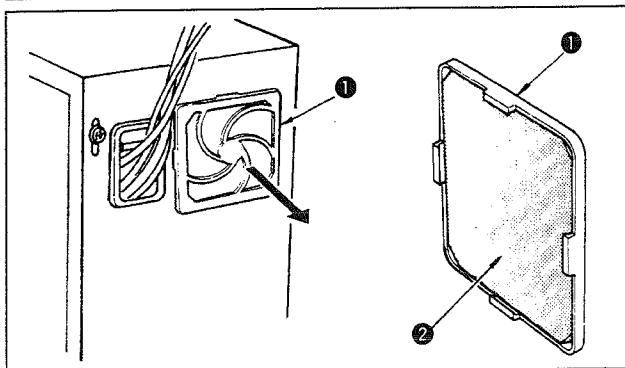

Clean the filter ② of the control box fan once every week.

- 1) Pull the screen kit ① in the direction of the arrow to remove it.
- 2) Wash the filter ② under running water.
- 3) Reinstall the filter and the screen kit ①.

8. Draining waste oil



WARNING :

Turn OFF the power before starting the work so as to prevent accidents caused by abrupt start of the sewing machine.

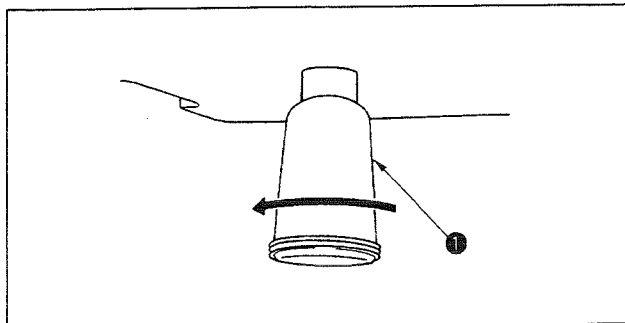

When polyethylene oiler ① becomes filled with oil, remove it and drain the oil.

9. Replacing the fuse



WARNING :

1. To avoid electrical shock hazards, turn OFF the power and open the control box cover after about five minutes have passed.
2. Open the control box cover after turning OFF the power without fail. Then, replace with a new fuse with the specified capacity.

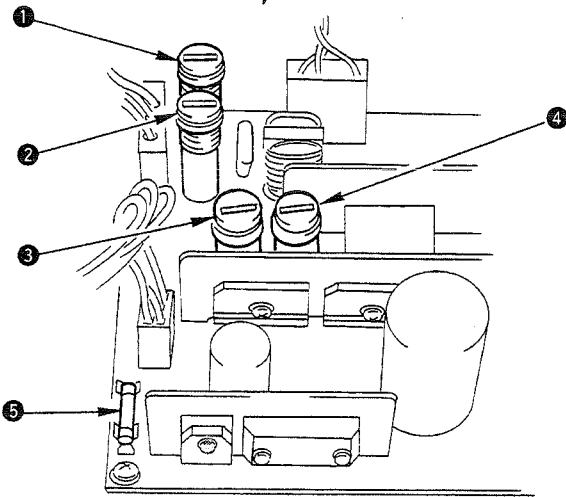
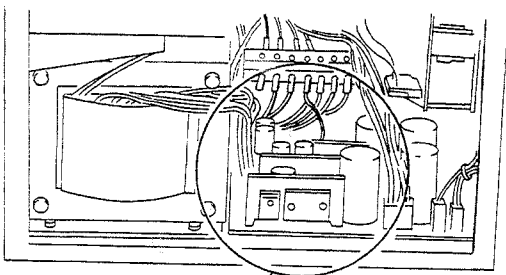

The machine uses the following five fuses :

- ①, ② For servo motor power supply protection
10A each (standard melting fuse)
- ③ For solenoid power supply protection
10A (standard melting fuse)
- ④ For stepping motor (X and Y) protection
5A (standard melting fuse)
- ⑤ For control power supply protection
5A (standard melting fuse)

VIII . HOW TO USE THE MEMORY SWITCH

1. Starting the memory switch



Pressing [5] of the numeral key, turn ON the power switch. Then, the indication by memory switch will appear and the sewing machine movements can be changed.

002. SCALE CONV	
INC / DEC	STITCH

2. Example of the memory switch setting

(1) Setting the bobbin thread counter indication





Change the bobbin thread counter from adding method to subtracting method, and the production counter from ON to OFF.

- 1) Pressing [Pattern No.] key, display "009 COUNTER" using   key.

Initial condition is as follows :





Bobbin thread counter : Adding method
Production counter : ON

<u>009. COUNTER</u>	
BOBBIN	UP
PRODUCT	ON

- 2) Pressing [X scale] key, press   key. Every time you press   key, the indication will change "UP" to "DOWN". Put "DOWN" on the display and press the [Enter] key.

Now, the adding method has been changed to the subtracting method.

009. COUNTER	
BOBBIN	<u>DOWN</u>
PRODUCT	ON



- 3) Pressing [Y scale] key, press   key. Every time you press   key, the indication will change "ON" to "OFF". Put "OFF" on the display and press the [Enter] key.

Now, the production counter has been changed to OFF.

009. COUNTER	
BOBBIN	DOWN
PRODUCT	<u>OFF</u>











(2) Setting enlarging / reducing function

The function of enlarging / reducing can be changed from increasing / decreasing number of stitches to increasing / decreasing sewing pitch.

- 1) Pressing the [Pattern No.] key, display "002 SCALE CONV" using   key.

Initial condition is of increasing / decreasing number of stitches.

<u>002. SCALE CONV</u>	
INC / DEC	STITCH









- 2) Pressing [Y scale] key, press   key. Every time you press   key, the indication will change in the order of "STITCH"   "PITCH"   "PROHIBIT"   "STITCH". Put "PITCH" on the display and press the [Enter] key. Now, the enlarging / reducing function is of increasing / decreasing the sewing pitch.

002. SCALE CONV	
INC / DEC	<u>PITCH</u>

3. Basis operation

Function No. Contents of function	①
Contents of Item 1 – Contents of setting Item 1	②
Contents of Item 2 – Contents of setting Item 2	③
Contents of Item 3 – Contents of setting Item 3	④

Setting procedures of changing the respective items.

- ① Function No.
Change the [Pattern No.] key using   key.
- ② Contents of setting Item 1
Change the [X scale] key using   key.
- ③ Contents of setting Item 2
Change the [Y scale] key using   key.
- ④ Contents of setting Item 3
Change the [Bobbin thread counter] key using   key.



The respective items will be decided by the [Enter] key after being set by the   key.

Table of functions of the memoly switch

* Setting value in is the initial setting value.

No.	Function	Item	Setting value	Description
002	SCALE CONV	INC / DEC	<input type="text"/> / PITCH / OFF	Under enlargement / reduction mode, data setting is fixed as stitch / pitch / 100%.
003	JOG MODE	MODE	PARA / <input type="text"/> / OFF	This mode sets the movement of sewing position or turn-out position.
004	RETAINER	RESET	ON / <input type="text"/>	This selects ON / OFF of the retainer compensation.
008	ON ABORT	MODE	<input type="text"/> / HOME & / TRACE	This selects the route of origin retrieval.
		AUDET	<input type="text"/> / ON	Origin retrieval : When the machine retrieves, this sets if the needle should be raised to the highest position.
009	COUNTER	BOBBIN	<input type="text"/> / DOWN	This changes UP / DOWN of the bobbin thread counter.
		PRODUCT	<input type="text"/> / OFF	This sets ON / OFF of the production counter.
013	STOP SW	TRIM	<input type="text"/> / AUTO / NDL	This sets the thread trimmer switch after temporary stop.
023	FUNC KEY	F1	-1~ (INITIAL STAGE : 2nd origin)	This will select the function of F1 key.
		F2	-1~ (INITIAL STAGE : INPUT ARC)	This will select the function of F2 key.
027	NDL UP DTCT	POSITION	<input type="text"/> / AUDET	This sets the stopping position of the needle bar.
028	MOTOR SPEED	ACCEL	0 TO 5 (INITIAL STAGE : 0)	This sets the sewing speed at the sewing start. Soft start for 3 stitches (0 to 4) and 5 stitches (5) can be set.
029	MOTOR SYNC	PCH-SPD	0 TO 3 (INITIAL STAGE : 0)	0 : 2,500 s.p.m. / 3 mm 1 : 2,000 s.p.m. / 3 mm 2 : 1,700 s.p.m. / 3 mm 3 : 1,300 s.p.m. / 3 mm
		PAUSE	0 TO 9 (INITIAL STAGE : 0)	Every time you increase by one, you can advance the feed end of X / Y scale by 8°.
030	OUTER PRSR 1	PEDAL	<input type="text"/> / 1 / 2 / 3	Opening or closing of the feeding frame can be controlled by operating the pedal.
		PAUSE	<input type="text"/> / 1 / 2 / 3	Opening or closing of the feeding frame after temporary stop can be controlled by operating the pedal.
031	OUTER PRSR 2	RELEASE	<input type="text"/> / HOLD / ATEND	This selects the way of lifting the feeding frame after the sewing is finished.
		HOLDING	OFF / <input type="text"/>	This keeps the feeding frame held lowered.
032	PEDAL MODE 1	PEDAL 1	<input type="text"/> / FLIP	The feeding frame can be lowered while the pedal 1 is held depressed.
		PEDAL 2	<input type="text"/> / FLIP	The feeding frame can be lowered while the pedal 2 is held depressed.
		PEDAL 3	<input type="text"/> / FLIP	The feeding frame can be lowered while the pedal 3 is held depressed.
033	PEDAL MODE 2	PEDAL 4	<input type="text"/> / FLIP	The feeding frame can be lowered while the pedal 4 is held depressed.
035	I. PRSR	SWITCH	OFF / <input type="text"/> / TRIAL	The movement of the intermediate presser can be prohibited.
		DOWN AT	O.PRSR / <input type="text"/>	The timing of the movement of the intermediate presser can be coordinated with the feeding frame.
038	T.BRK DTCT	SWITCH	<input type="text"/> / OFF	This sets ON / OFF of the thread breakage detector.
039	AIR PRSR	SWITCH	ON / <input type="text"/>	This sets if the air pressure is checked.

* Memory functions may differ in accordance with the types of machine.

IX . INPUT MODE

1. Names of the switches for input mode

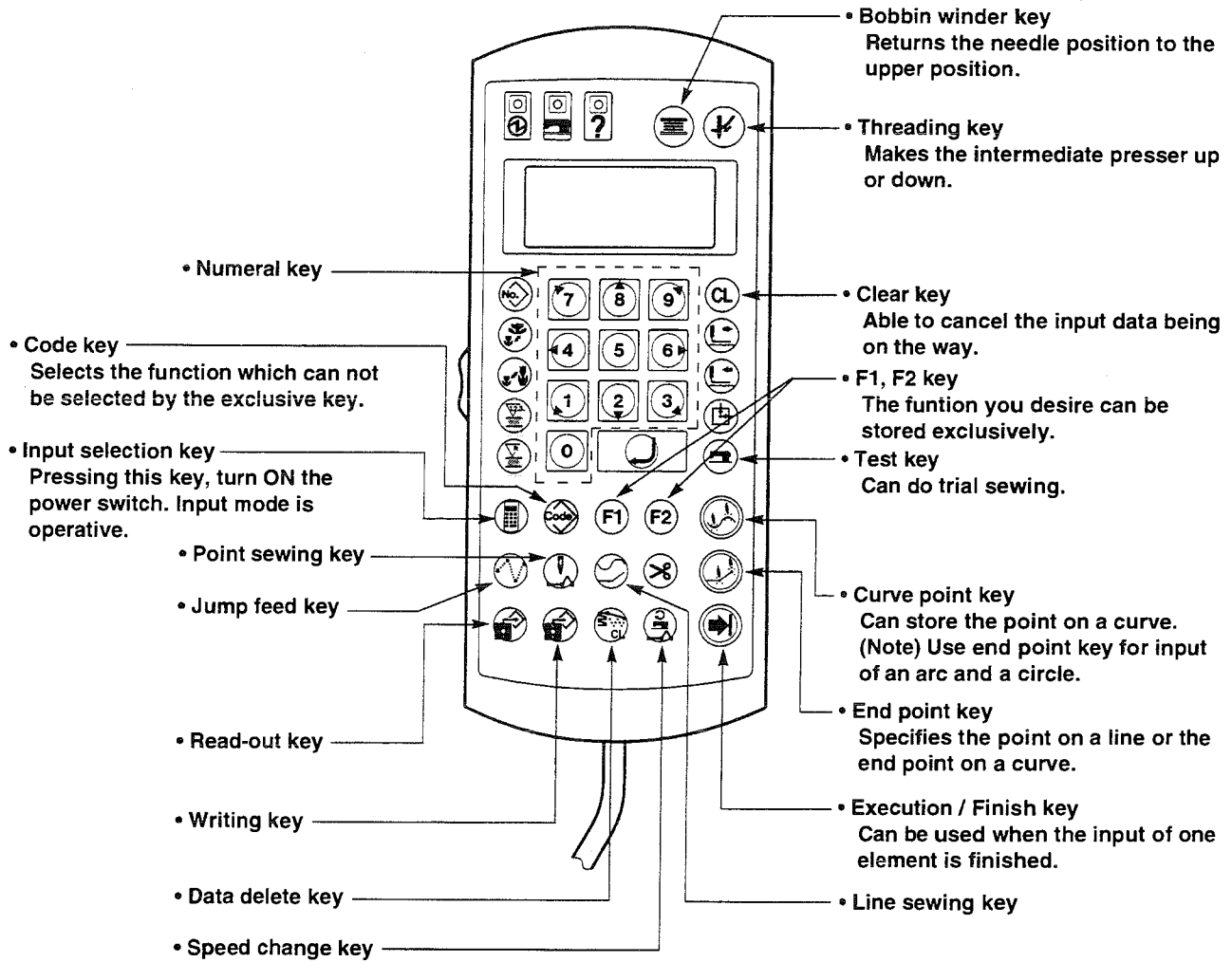

2. Operation of input mode

(1) Starting the input mode

Input mode starts when pressing the [Input selection] key, the power switch is turned ON. (Display ①)

A : Shows the origin.

-->> { >-- Top
 -->> { --> End point of element
 -->> { --> End point of pattern

```
Origin                ==>>
X = + 00000A
Y = + 00000
Select Function
```

Display ①

(2) Selecting the function

Way of selecting the function is as follows :

- (1) Selection by the exclusive key
 Selection by the exclusive key on the operation panel.
- (2) Selection from the function No.
 Specify by [Code] key → Numeral key and select by [Enter] key.
 Refer the function No. to the separate table.
- (3) Selection from the table of functions
 Selection is made in the following order : [Code] key → [Execution / Finish] key → indication scroll by  key → [Execution / Finish] key.

```
N = 000
X = + 00000R
Y = + 00000
Jump
```

Display ②

N : Point stored

R : Shows the point of sewing start

Display ② will be shown while the selection of function is being executed.

(3) Numeral input

In case the function specifying the numeral value of stitch length or the like is input, display ③ is shown before display ②.

After input is finished, display ② will appear by means of [Execution / Finish] key.

```
P = 020 (0.1 mm)
W = 010 (0.1 mm)
S = 1 (1 : L, 2 : R)
Input P                No 034
```

Display ③

P : Stitch length

W : Off-set, zigzag width

S : Direction of off-set

3. Example 1 of pattern input (Disk format)

When using a new disk, be sure to initialize it to make it adaptable to a device.

- 1) Pressing the [Input selection] key, turn ON the power switch. The mode enters to the input mode.

(Caution) Keep the [Input selection] key held pressed until the indication appears after the origin retrieval has been performed.

Origin	- > >
X = + 00000A	
Y = + 00000	
Select Function	

- 2) Press the [Code] key.

No = 000
Select Function

- 3) Press the numeral keys [9] and [0], then press the [Enter] key.
Format function No. = 090

No = 090
FD Formatting

- 4) Press the [Execution/Finish] key.

K = 1 (1 : 1.44M (2HD) 2 : 720K (2DD))	
Kind of FD	No 090

- 5) Press the numeral key [1] in case of 2HD disk, and the numeral key [2] in case of 2DD disk. Then, press the [Execution/Finish] key.

Sure (Y/C)

- 6) After inserting the floppy disk, press the [Execution/Finish] key.
The machine starts to format. It takes about four minutes.

Formatting

After the formatting has been completed, the indication will return to the item 1).

4. Example 2 of pattern input

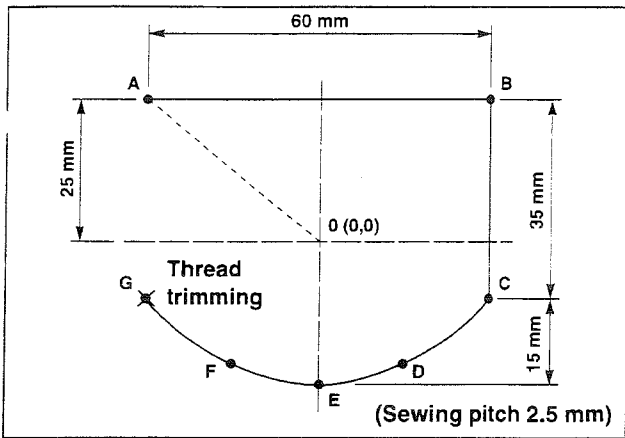

The procedures of the pattern described on the left are shown as follows :

- (1) Pattern input
- (2) Trial sewing
- (3) Writing into a floppy disk

(1) Pattern input

- 1) Pressing the [Input selection] key, turn ON the power switch. The feeding frame comes down and the origin retrieval performance is made.

(Note) Keep the [Input selection] key held pressed until the origin retrieval performance is made and the display appears.

When the display appeared, insert a piece of paper or the like on which the shape of input is drawn by raising / lowering the feeding frame by means of the feeding frame switch.

- 2) Press the [Jump] key.

```
Origin                - > >
X = + 00000A
Y = + 00000
Select Function
```

- 3) Move the feeding frame from 0 to A by the direction key. (Amount of movement is indicated by 0.1 mm unit.)

```
N = 000
X = + 00000R
Y = + 00000
Jump
```

```
N = 000
X = - 00300R
Y = + 00250
Jump
```

- 4) When the [Execution / Finish] key is pressed, the feeding frame will return to the starting point "0", and the jump feed from 0 to A will be performed.

```
Jump                    > > >
X = - 00300A
Y = + 00250            S = * *
Select Function
```

- 5) Press the [Line] key

```
P = 020 (0.1 mm)
```

```
Input P                No 022
```

- 6) As the pitch is set 2.5 mm, input [0][2][5] by the numeral key, and press the [Execution / Finish] key.

```
N = 000
X = + 00000R          P = 025
Y = + 00000
Sewing
```

7) Move the feeding frame from A to B by the direction key, and press the end point key.

* Line sewing input can input the line and the curve. Input of the end point of the line or the curve is made by pressing the [Point] key and input of a point on the curve is made by pressing the [Curve point] key.

N = 001	
X = + 00600R	P = 025
Y = + 00000	
Sewing	

8) Move the feeding frame from B to C by the [Direction] key, and press the end point key.

N = 002	
X = + 00600R	P = 025
Y = - 00350	
Sewing	

9) Move the feeding frame from C to D by the [Direction] key, and input by the curve point key.

N = 003	
X = + 00500R	P = 025
Y = - 00450	
Sewing	

10) Move the feeding frame from D to E by the direction key, and input by the [Curve point] key.

N = 004	
X = + 00300R	P = 025
Y = - 00500	
Sewing	

11) Move the feeding frame from E to F by the [Direction] key, and input by the curve point key.

N = 005	
X = + 00200R	P=025
Y = - 00450	
Sewing	

12) Move the feeding frame from F to G by the [Direction] key, and input by the end point key.

N = 006	
X = + 00000R	P = 025
Y = - 00350	
Sewing	

13) Press the [Execution / Finish] key, and the line sewing is finished. The feeding frame returns to A point and passes A → B → C → D → E → F → G.

Spline	- >>
X = - 00300A	P = 025
Y = - 00100	S = * *
Select Function	

14) Press the [Thread trimming] key, and input the thread trimming.

Thread Trimmer	- >>
X = - 00300A	P = 025
Y = - 00100	S = * *
Select Function	

Input procedures end as above.

Shape of input can be confirmed by the [Forward], [Backward] key.

(2) Test sewing

- 1) Press the [Test] key.
The feeding frame moves to A point and goes up.
- 2) Sewing in the order of the normal sewing can be performed.
- 3) Press the [Test] key after confirming the completion of sewing.
The feeding frame comes down and stops at the origin after the origin retrieval.

No = 001	JOG MODE
XS = 1000	
YS = 1000	

Jump	
X = 00000R	
Y = 00000	S = * *
Select Function	

Under this condition, the feeding frame can be moved by the [Forward] / [Backward] key, and the amendment of pattern can be made.

(3) Writing

- 1) Press the [Writing] key.
- 2) Specify the pattern No. desired by means of the numeral key.
- 3) By pressing the [Execution / Finish] key, writing into a floppy disk can be performed.
- 4) If the pattern No. specified is already used, the display will appear as shown in the figure on the right. In this case, indicate if the previous data should be cancelled.
[Execution / Finish] key → Writing over
(delete the previous data)
[Clear] key → Cancellation
- 5) After the writing is finished, the display will be back to the previous condition.

N = 001	
Input Wrt	No 81

No = 123	
Input Wrt	No 81

No = 123	
Writing Pattern	

No = 123	
Over Write (Y/C)	

5. Example 3 of pattern input

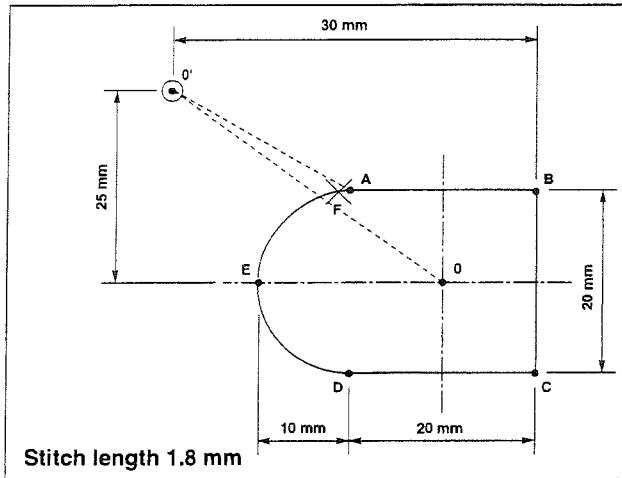

When the needle point is at the sewing start, it may interfere with setting the material. In this case, input the second origin as shown in the figure.

- 1) Pressing the [Input selection] key, turn ON the power switch.
The feeding frame comes down, and origin retrieval performance is made.

(Note) Keep the [Input selection] key held pressed until the display appears after the origin retrieval.

When the display appeared, insert a piece of paper or the like on which the shape of input is written under the feeding frame by lowering or raising the feeding frame.

- 2) Press the [Jump] key.

```
Origin                - >>
X = + 00000A
Y = + 00000
Select Function
```

- 3) Move the feeding frame to O' by the direction key.

```
N = 000
X = + 00000R
Y = + 00000
Jump
```

- 4) Press the [Execution / Finish] key.

```
N = 000
X = - 00300R
Y = + 00250
Jump
```

- 5) Press the [F1] key.

(Note) In the [F1] key "Second origin" is input as the initial condition.

```
Jump                  >>>
X = - 00300A
Y = + 00250          S = * *
Select Function
```

- 6) Press the [Jump] key.

```
Sec - Origin
X = - 00300A
Y = + 00250
Select Function
```

```
N = 000
X = + 00000R
Y = + 00000
Jump
```

7) Move the feeding frame from 0' to A by the direction key.

N = 000
X = + 00200R
Y = - 00150
Jump

8) Press the [Execution / Finish] key.

Jump
X = + 00100A
Y = - 00100 S = * *
Select Function

9) Press the [Line] key.

P = 020 (0.1 mm)

Input P

10) As the stitch length is set 1.8 mm, input [0][1][8] by the numeral key, and press the [Execution / Finish] key.

N = 000
X = + 00000R P = 018
Y = + 00000
Sewing

11) Move the feeding frame from A to B by the direction key, and press the [End point] key.

N = 001
X = + 00200R P = 018
Y = + 00000
Sewing

12) Move the feeding frame from B to C by the direction key, and press the [End point] key.

N = 002
X = + 00200R P = 018
Y = - 00200R
Sewing

13) Move the feeding frame from C to D by the direction key, and press the [End point] key.

N = 003
X = + 00000R P = 018
Y = - 00200
Sewing

14) Press the [Execution / Finish] key.

Linear
X = - 00100A P = 018
Y = - 00100 S = * *
Select Function

15) For D~E~F arc input is made. In this case, however, selection of function is made from the indication of the table of functions of the memory switch.



Press the [Code] key.

No = 000

Select Function

16) Press the [Enter] key or the [Execution / Finish] key.

001 = Thread Trimr
002 = Sec - Origin
003 = Temp Stop
004 = Refer Point

17) Select the arc input by   key.

025 = Arc	Sewing
026 = Circle	Sewing
030 = Linear	Zig
031 = Spline	Zig

18) Press the [Execution / Finish] key..

P = 018 (0.1 mm)

Input P	No 025
---------	--------

19) As the stitch length is set 1.8 mm as before, press the [Execution / Finish] key.

N = 000	
X = + 00000R	P = 018
Y = + 00000	
Arc	

20) Move the feeding frame from D to E by the direction key, and press the [End point] key.

N = 001	
X = - 00100R	P = 018
Y = + 00100	
Arc	

21) Move the feeding frame from E to F by the direction key, and press the [End point] key.

N = 002	
X = + 00000R	P = 018
Y = + 00200	
Arc	

22) Press the [Execution / Finish] key.

Arc	
X = - 00100A	P = 018
Y = + 00100	S = * *
Select Function	

23) Press the [Thread trimming] key.

Thread Trimr
X = - 00100A
Y = + 00100
Select Function

The input procedures now have been completed.

The shape of input can be confirmed by the [Forward] / [Backward] key.

6. Example of the change of sewing speed

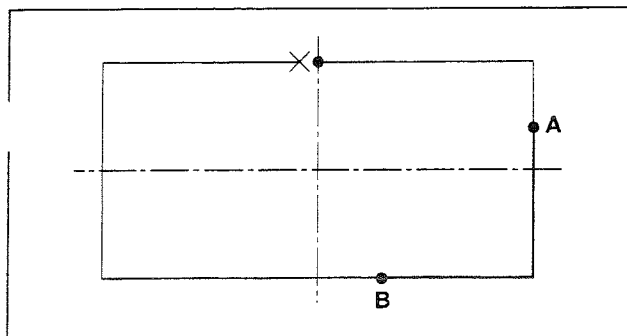

In case of changing a part of the sewing speed of the service pattern (No. 501)
Changing the sewing speed between A and B to 1,000 s.p.m.

- 1) Pressing the [Input selection] key, turn ON the power switch.
The feeding frame comes down and the origin retrieval is performed.

(Note) Keep the [Input selection] key held pressed until the display appears after the origin retrieval.

```
Origin                - > >
X = + 00000A
Y = + 00000
Select Function
```

- 2) Press the [Read] key.

```
No = 123
X = 1000 (0.1 %)S
Y = 1000 (0.1 %)
Input Read           No 080
```

- 3) Input [5][0][1] by the numeral key.
(This time, read out 100% without enlargement / reduction mode.)

```
No = 501
X = 1000 (0.1 %)S
Y = 1000 (0.1 %)
Input Read           No 080
```

- 4) Press the [Execution / Finish] key.

```
Origin                - > >
X = + 00000A
Y = + 00000
Select Function
```

- 5) Advance the feeding frame to A point by the [Forward] / [Backward] key.

```
Linear
X = + 00300A          P = 020
Y = + 00010          S = * *
Select Function
```

- 6) Press the [Speed change] key.

```
S = 25 (100 spm)

Input SP             No 061
```

- 7) Input [1][0] by the numeral key.

```
S = 10 (100 spm)

Input SP             No 061
```

8) Press the [Execution / Finish] key.

Linear	
X = + 00300A	P = 020
Y = + 00010	S = * *
Chg Pt - Sp	N = 0001

9) Press the [Forward] key, and move the feeding frame to the position B.

Linear	
X = + 00080A	P = 020
Y = - 00150	S = * *
Chg Pt - Sp	N = 0020

10) Press the [Execution / Finish] key.

Linear	
X = + 00080A	P = 020
Y = - 00150	S = 10
Select Function	

The sewing speed between A and B will become 1,000 s.p.m. after the above procedures have been completed. Write the data in a floppy, and retain it.

When the feeding frame is moved by the [Forward] – [Backward] key, the indication of S = 10 is shown between A and B. It is, therefore, confirmed that the sewing speed has been changed.

7. Example 4 of pattern input (Automatic back tuck)

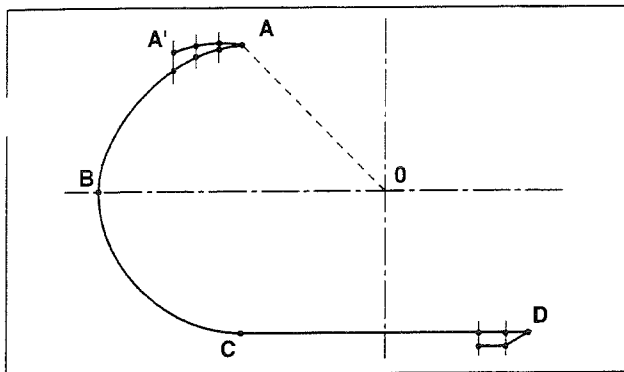

At first, input the arc ABC and the line CD. Then, input 3 stitches at the sewing start and 2 stitches at the sewing end.

- 1) Pressing [Input selection] key, turn ON the power switch.
The feeding frame comes down and the origin retrieval will be performed.

(Note) Keep the [Input selection] key held pressed until the display appears after the origin retrieval has been performed.

When the display appeared, insert a piece of paper or the like on which the shape of input is written under the feeding frame by raising / lowering the feeding frame by means of the feeding frame switch.

- 2) Press the [Jump] key.

```
Origin          - >>>
X = + 00000A
Y = + 00000
Select Function
```

- 3) Move the feeding frame from 0 to A by the moving key.

```
N = 000
X = + 00000R
Y = + 00000
Jump
```

- 4) Press the [Execution / Finish] key.

```
N = 000
X = - 00200R
Y = + 00200
Jump
```

- 5) Press the [F2] key.
(The arc sewing is set in the F2 key at the time of delivery.)

```
Jump          >>>
X = - 00200A
Y = + 00200    S = * *
Select Function
```

- 6) Input [0][3][0] in order by the numeral key, and press the [Execution / Finish] key.

```
P = 020 (0.1 mm)

Input P          No 025
```

```
N = 000
X = + 00000R    P = 030
Y = + 00000
Arc
```

7) Move the feeding frame from A to B by the moving key, and indicate by the [End point] key.

(Use the [End point] key for indicating the position when the circle or the arc is input.)

```
N = 001
X = - 00200R      P = 030
Y = - 00200
Arc
```

8) Move the feeding frame from B to C by the moving key, and indicate by the [End point] key.

```
N = 002
X = + 00000R      P = 030
Y = - 00400
Arc
```

9) Press the [Execution / Finish] key.

```
Arc - >>
X = - 00200A      P = 030
Y = - 00200      S = * *
Select Function
```

10) Press the [Line] key.

```
P = 030 (0.1 mm)
```

```
Input P      No 022
```

11) Press the [Execution / Finish] key as the sewing pitch has not to be changed from 3 mm.

```
N = 000
X = + 00000R      P=030
Y = + 00000
Sewing
```

12) Move the feeding frame from C to D by the moving key, and input by the [End point] key.

```
N = 001
X = + 00500R      P = 030
Y = + 00000
Sewing
```

13) Press the [Execution / Finish] key.

```
Linear >>>
X = + 00300A      P = 030
Y = - 00200      S = * *
Select Function
```

14) Press the [Code] key.

```
No = 000
```

```
Select Function
```

15) Press [0][6][4] in order by the numeral key, and press [Enter] key.

```
No = 64
```

No = 064 of the back tuck is shown.

```
Back - Tuck
```

16) Press the [Executin / Finish] key.

```
SN = 0
EN = 0
T = 1 (1 : V, 2 : Z)
Input Num      No 064
```

17) Press [3] by the numeral key, and press [Enter] key.
(Input 3 stitches, the number of back tuck stitches at the sewing start.)

```
SN = 3
EN = 0
T = 1 (1 : V, 2 : Z)
Input Num      No 064
```

18) Press 2 by the numeral key, and press [Enter] key.
(Input 2 stitches, the number of back tuck stitches at the sewing end.)

```
SN = 3
EN = 2
T = 1 (1 : V, 2 : Z)
Input Type     No 064
```

19) Indicate the type of back tuck.
Take the V type for example, press [1], and press [Enter] key.
1 : V type
2 : Z type

```
SN = 3
EN = 2
T = 1 (1 : V, 2 : Z)
Input Num      No 064
```

20) Press the [Execution / Finish] key.

```
Linear          >>-
X = + 00300A    P = 030
Y = - 00200     S = * *
Select Function
```

21) Advance to the final point by the [Forward] key.

```
Point          -->>
X = + 00242A
Y = - 00200     S = * *
Select Function
```

22) Press the [Thread trimmer] key.

```
Thread Trmr    -->>
X = + 00242A
Y = - 00200
Select Function
```

23) It is confirmed that the back tuck is made by means of the [Forward] or the [Backward] key.
The jump feed from 0 to A is automatically changed to 0 to A'.

8. Example 5 of pattern input (Condensation stitching)

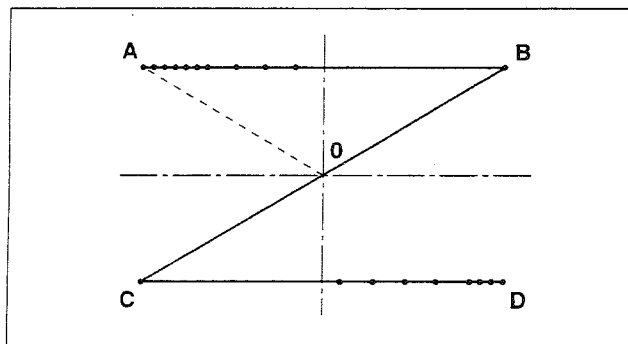

At the start, make the linear sewing, A-B-C-D, and sewing pitch of 2.5 mm. And, the condensation stitching which makes the sewing pitch finer, is to be performed at the start and end of sewing.

Specify the numbers of the respective stitches at the start and end of sewing and the pitch of condensation stitching.

1) Pressing the [Input selection] key, turn ON the power switch.

(Note) Keep the [Input selection] key held pressed until the display appears after the origin retrieval has been performed.

When the display appeared, insert a piece of paper or the like on which the shape of input is written under the feeding frame by raising / lowering the feeding frame by means of the feeding frame switch.

2) Press the [Jump] key.

3) Move the feeding frame from 0 to A by the moving key.

4) Press the [Execution / Finish] key.

5) Press the [Line] key.

6) Press the numeral key in the order of [0][2][5], and press the [Execution / Finish] key.
(Stitch length 2.5 mm)

```
Origin                - > >
X = + 00000A
Y = + 00000
Select Function
```

```
N = 000
X = + 00000R
Y = + 00000
Jump
```

```
N = 000
X = - 00250R
Y = + 00150
Jump
```

```
Jump                  > > >
X = + 00250A
Y = + 00150          S = * *
Select Function
```

```
P = 020 (0.1 mm)
```

```
Input P              No 022
```

```
N = 000
X = + 00000R        P = 025
Y = + 00000
Sewing
```

7) Move the feeding frame from A to B by the moving key, and press the [End point] key.

```
N = 001
X = + 00500R      P = 025
Y = + 00000
Sewing
```

8) Move the feeding frame from B to C by the moving key, and press the [End point] key.

```
N = 002
X = + 00000R      P = 025
Y = + 00300
Sewing
```

9) Move the feeding frame from C to D by the moving key, and press the [End point] key.

```
N = 003
X = + 00500R      P = 025
Y = - 00300
Sewing
```

10) Press the [Execution / Finish] key.

```
Linear                >>>
X = + 00250A          P = 025
Y = - 00150           S = * *
Select Function
```

11) Press the [Thread trimming] key.

```
Thread Trimr         -->>
X = + 00250A
Y = - 00150
Select Function
```

12) Return to the sewing part by the [Backward] key.
Condensation stitching has to be specified over the sewing part.

```
Linear                -->-
X = + 00250A          P = 025
Y = - 00150           S = * *
Select Function
```



13) Press the [Code] key.

```
No = 000

Select Function
```

14) Press the [Enter] key to make the table shown.

```
001 = Thread Trimr
002 = Sec - Origin
003 = Temp Stop
004 = Refer Point
```

15) Make the indication of the condensation stitching, No. 065, by operating the   key.

065 = Condensation	
066 = Over Stitch	
070 = Pt Del	R
071 = Pt Move	R

16) Press the [Execution / Finish] key.

SN = 0	
EN = 0	
P = 020 (0.1 mm)	
Input Num	No 065

17) Press [2] of the numeral key, and input it by the [Enter] key.
In this stage, the 2 stitches at the sewing start is changed to the condensation stitching.

SN = 2	
EN = 0	
P = 020 (0.1 mm)	
Input Num	No 065

18) Press [1] of the numeral key, and input it by the [Enter] key.
In this stage, the 1 stitch at the sewing end is changed to the condensation stitching.

SN = 2	
EN = 1	
P = 020 (0.1 mm)	
Input P	No 065

19) Press [0][0][8] of the numeral key, and input by the [Enter] key.
The sewing pitch of the condensation stitching is set 0.8 mm.

SN = 2	
EN = 1	
P = 008 (0.1 mm)	
Input P	No 065

20) Press the [Execution / Finish] key.

Point	-->--
X = + 00250A	
Y = - 00150	S = * *
Select Function	

21) The confirmation of the shape can be made by the [Forward] or [Backward] key.

9. Example 6 of pattern input (Double-stitch sewing)

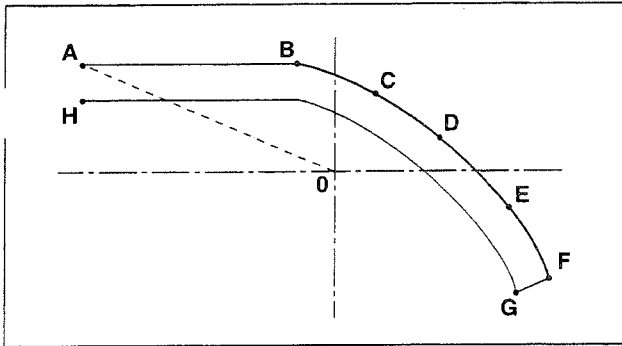

When inputting A-B-C-D-E-F using the function of the double-stitch sewing, double-stitch sewing of A-B-C-D-E-F-G-H can be made.

1) Pressing the [Input selection] key, turn ON the power switch.

(Note) Keep the [Input selection] key held pressed until the display appears after the origin retrieval has been performed.

When the display appeared, insert a piece of paper or the like on which the shape of input is written under the feeding frame by raising / lowering the feeding frame by means of the feeding frame switch.

2) Press the [Jump feed] key.

```
Origin          - > >
X = + 00000A
Y = + 00000
Select Function
```

3) Press the [Moving] key, and move the feeding frame from 0 to A.

```
N = 000
X = + 00000R
Y = + 00000
Jump
```

```
N = 000
X = - 00350R
Y = + 00150
Jump
```

4) Press the [Execution / Finish] key.

```
Jump          > > >
X = - 00350A
Y = + 00150      S = * *
Select Function
```

5) Press the [Code] key.

```
No = 000

Select Function
```

6) Press the [Enter] key.

```
001 = Thread Trimr
002 = Sec - Origin
003 = Temp Stop
004 = Refer Point
```

7) Press the  key, and select "Spline 2 Rvs".

045 = Spline	2Rvs
046 = Arc	2Rvs
047 = Circle	2Rvs
048 = Linear	Rev

8) Press the [Execution / Finish] key.

P = 020 (0.1 mm)	
W = 100 (0.1 mm)	
S = 1 (1 : L, 2 : R)	
Input P	No 045

9) As the pitch is set 2 mm, press [Enter] key.

P = 020 (0.1 mm)	
W = 100 (0.1 mm)	
S = 1 (1 : L, 2 : R)	
Input Wide	No 045

10) As the width is set 4 mm, indicate [0][4][0] by the numeral key, and press the [Enter] key.

P = 020 (0.1 mm)	
W = 040 (0.1 mm)	
S = 1 (1 : L, 2 : R)	
Input Side	No 045

11) The sewing line is made on the right side of the advancing direction of the input line. So, indicate the right side. Press [2] of the numeral key, and press the [Enter] key.

P = 020 (0.1 mm)	
W = 040 (0.1 mm)	
S = 2 (1 : L, 2 : R)	
Input P	No 045

12) Press the [Execution / Finish] key.

N = 000	
X = + 00000R	P = 020
Y = + 00000	W = 040R
Spline	2Rvs

13) Move the feeding frame from A to B by the moving key, and press the [End point] key.

N = 001	
X = + 00300R	P = 020
Y = + 00000	W = 040R
Spline	2Rvs

14) Move the feeding frame from B to C by the moving key, and press the [Curve point] key.

N = 002	
X = + 00400R	P = 020
Y = - 00050	W = 040R
Spline	2Rvs

15) Move the feeding frame from C to D by the moving key, and press the [Curve point] key.

N = 003	
X = + 00500R	P = 020
Y = - 00100	W = 040R
Spline	2Rvs

16) Move the feeding frame from D to E by the moving key, and press the [Curve point] key.

N = 004	
X = + 00600R	P = 020
Y = - 00200	W = 040R
Spline	2Rvs

17) Move the feeding frame from E to F by the moving key, and press the [End point] key.

N = 005	
X = + 00650R	P = 020
Y = - 00300	W = 040R
Spline	2Rvs

18) Press the [Execution / Finish] key.

Spline	- > >
X = - 00350A	P = 020
Y = + 00110	S = * *
Select Function	

19) Press the [Thread trimming] key.

Tread Trimr	- > >
X = - 00350A	
Y = + 00110	
Select Function	

20) The procedures have been completed.
Confirm the shape by operating the [Forward] or [Backward] key.

10. Example 7 of pattern input (Overlapping stitching)

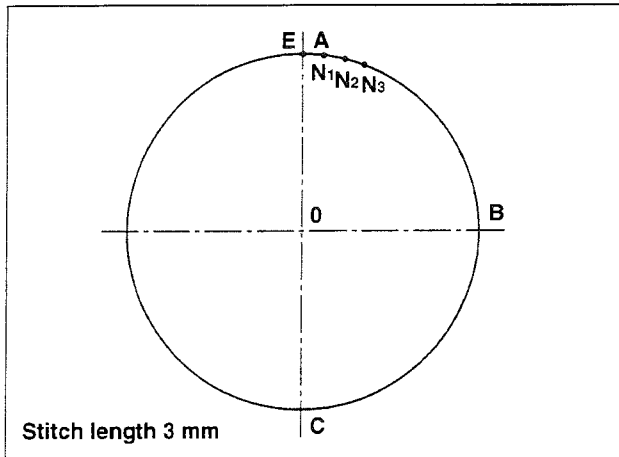

After the circle, ABCE, is made, from the end point of the circle, E, the stitches are made so as to overlap N_1 , N_2 and N_3 .

- 1) Pressing the [Input selection] key, turn ON the power switch.
The feeding frame comes down, and the origin retrieval is performed.

(Note) Keep the [Input selection] key held pressed until the display is shown after the origin retrieval has been performed.

When the display appeared, insert a piece of paper or the like on which the shape of input is written under the feeding frame by raising / lowering the feeding frame by means of the feeding frame switch.

- 2) Press the [Jump] key.

```
Origin                - >>>
X = + 00000A
Y = + 00000
Select Function
```

- 3) Move the feeding frame from 0 to A by the moving key.

```
N = 000
X = + 00000R
Y = + 00000
Jump
```

- 4) Press the [Execution / Finish] key.

```
N = 000
X = + 00000R
Y = + 00250
Jump
```

- 5) Press the [Code] key.

```
Jump                >>>
X = + 00000A
Y = + 00250          S = * *
Select Function
```

```
N = 000

Select Function
```

15) Press the [Execution / Finish] key.

Sure (Y / C)
Over Stitch

16) Press the [Execution / Finish] key.

Circle	>>>
X = + 00000A	P = 030
Y = + 00250	S = **
	N = 000

17) Move the feeding frame to the position N₁ by the [Forward] or [Backward] key, and indicate by the [End point] key.

(Indication of the position for the overlapping stitching is performed by the [Forward] or [Backward] key. The moving key is not effective.)

Circle	---
X = + 00030A	P = 030
Y = + 00248	S = * *
Over Stitch	N = 0001

18) Move the feeding frame to the position N₂ by moving one stitch using the [Forward] key, and indicate by the [End point] key.

Circle	---
X = + 00059A	P = 030
Y = + 00243	S = * *
Over Stitch	N = 0002

19) Move the feeding frame to the position N₃ by moving one stitch using the [Forward] key, and indicate by the [End point] key.

Circle	---
X = + 00088A	P = 030
Y = + 00234	S = * *
Over Stitch	N = 0003

20) Press the [Execution / Finish] key.

Point	->>
X = + 00088A	
Y = + 00234	S = * *
Select Function	

21) Press the [Thread trimming] key.

Thread Trmr	->>
X = + 00000A	
Y = + 00234	
Select Function	

22) The procedures have been completed. Confirm the shape by the [Forward] or [Backward] key.

11. Table of the function No. of the input mode

Function No.	Function	Description
001	Thread Trimr	Thread trimming is set.
002	Sec-Origin	Inputs the jump feed from the origin and sets the second origin.
003	Temp Stop	Temporarily stops the sewing machine during sewing a pattern.
004	Refer Point	Sets the reference point for enlargement / reduction.
005	Pt Enlg Edcn	Actuates the inverting crank.
006	One-Turn	This function is used to turn the sewing machine one turn while the feed is stopped.
007	Mark 2	Makes ON / OFF the thread tension No. 3.
008	Mark 1	Sets the pattern skip.
010	Delay	Used in combination with the external output to wait for the time required.
011	Ext Input	Waits for the signals transmitted from the outer devices.
012	Ext Output	Transmits signals to the outer devices.
013	Int Pre Adj	Makes ON / OFF the adjusting device for the height of the intermediate presser.
020	Jump	The feed only moves without sewing the workpiece.
021	Point Sewing	Makes the sewing data for every single stitch.
022	Sew Abs Cord	Makes the sewing data for the linear sewing and curve sewing.
023	Linear	Makes the sewing data for the linear sewing.
024	Spline	Makes the sewing data for the curve sewing.
025	Arc	Makes the sewing data for the arc sewing.
026	Circle	Makes the sewing data for the circle sewing.
030	Linear Zig	The base line is indicated as the linear to enter the data for the zigzag stitching.
031	Spline Zig	The base line is indicated as the curve to enter the data for the zigzag stitching.
032	Arc Zig	The base line is indicated as the arc to enter the data for the zigzag stitching.
033	Circle Zig	The base line is indicated as the circle to enter the data for the zigzag stitching.
034	Linear Ofs	Makes the sewing data for the linear sewing with a predetermined distance from the line specified.
035	Spline Ofs	Makes the sewing data for the curve sewing with a predetermined distance from the curve specified.
036	Arc Ofs	Makes the sewing data for the arc sewing with a predetermined distance from the arc specified.
037	Circle Ofs	Makes the sewing data for the circle sewing with a predetermined distance from the circle specified.
040	Linear 2Norm	Makes the sewing data for the linear sewing making the double-stitch sewing in the same direction.
041	Spline 2Norm	Makes the sewing data for the curve sewing making the double-stitch sewing in the same direction.
042	Arc 2Norm	Makes the sewing data for the arc sewing making the double-stitch sewing in the same direction.
043	Circle 2Norm	Makes the sewing data for the circle sewing making the double-stitch sewing in the same direction.

Function No.	Function	Description
044	Linear 2Rvs	Makes the sewing data for the linear sewing making the double-stitch sewing in the reverse direction.
045	Spline 2Rvs	Makes the sewing data for the curve sewing making the double-stitch sewing in the reverse direction.
046	Arc 2Rvs	Makes the sewing data for the arc sewing making the double-stitch sewing in the reverse direction.
047	Circle 2Rvs	Makes the sewing data for the circle sewing making the double-stitch sewing in the reverse direction.
050	Linear Rev	Makes the sewing data for the linear sewing making sewing two times in the reverse direction.
051	Spline Rev	Makes the sewing data for the curve sewing making sewing two times in the reverse direction.
052	Arc Rev	Makes the sewing data for the arc sewing making sewing two times in the reverse direction.
053	Circle Rev	Makes the sewing data for the circle sewing making sewing two times in the reverse direction.
060	Jump Spd	Sets the speed of the jump data input.
061	Chg Pt-Sp	Sets the sewing speed in the section designated in the sewing data input.
062	S-Len Change	Changes the sewing pitch.
063	Element Del	Can delete the input data by the unit of element.
064	Back-Tuck	Creates the back-tuck data.
065	Condensation	Creates the condensation stitching data.
066	Over Stitch	Can input the point sewing using the [Forward] or [Backward] key.
070	Pt Del R	Deletes the sewing point, and the data after the deleted sewing point will move.
071	Pt Move R	Moves the sewing points, and the data after the sewing point has been moved will move.
072	L-Apex Del R	Deletes the top point of the linear, and the data after the deleted top point will move.
073	L-Apex Mov R	Moves the top point of the linear, and the data after the top point has been moved will move.
074	Pt Del A	Deletes the sewing point, and the data after the sewing point will not move.
075	Pt Move A	Moves the sewing point, and the data after the sewing point will not move.
076	Pt Add A	Adds the sewing point, the data after the sewing point will not move.
077	L-Apex Del A	Deletes the top point of the linear, and the data after the top point has been deleted will not move.
078	L-Apex Mov A	Moves the top point of the linear, and the data after the top point will not move.
080	Patt Read	Pattern data stored on the floppy disk can be read out from it.
081	Patt Write	Can write the sewing pattern onto the floppy disk.
082	X Symmetry	Adds the shape that the needle position is symmetrical to the x-axis.
083	Y Symmetry	Adds the shape that the needle position is symmetrical to the y-axis.
084	Pt Symmetry	Adds the shape that the center of needle position is symmetrical to the point.

Function No.	Function	Description
085	Patt Move	Moves the position of the sewing pattern. Note 1.
086	Patt Copy	Copies the sewing pattern in the specified range. Note 1.
087	Patt Del	Deletes the sewing pattern data.
090	FD Format	Initializes the floppy disk.
091	Inverse Set	Inputs in case the inversion crank is used for the sewing pattern.
092	Temp Chg Sp	Can control the sewing speed.
093	Refer Value	Number of all stitches stored in the pattern data will be shown.
110	End Method	When the end/execution is performed, sets if the data should be traced.
111	Crd Sys Chng	Selects the co-ordinate indication whether the absolute or the relative one.

(Note) 1. When the needle position is located in the jump feed section between the origin and the sewing start, the function selection can not be made.

X . OPTIONAL

1. Table of Needle hole guide

No	Part No.	Size (mm)	Remarks
1	B242621000A	ø 1.6	Standard for S specification
2	B242621000B	ø 2.0	Standard for H specification
3	B242621000C	ø 1.6	Optional for knits
4	B242621000D	ø 2.4	Optional for heavy-weight materials
5	B242621000F	ø 3.0	Optional for heavy-weight materials
6	B242621000G	ø 3.0 (with a counterbore)	Optional for extra heavy-weight materials
7	B242621000H	ø 3.0 (eccentric hole)	Optional for heavy-weight materials to prevent skip-stitching

2. Silicon oil tank



WARNING :

Turn OFF the power before starting the work so as to prevent accidents caused by abrupt start of the sewing machine.

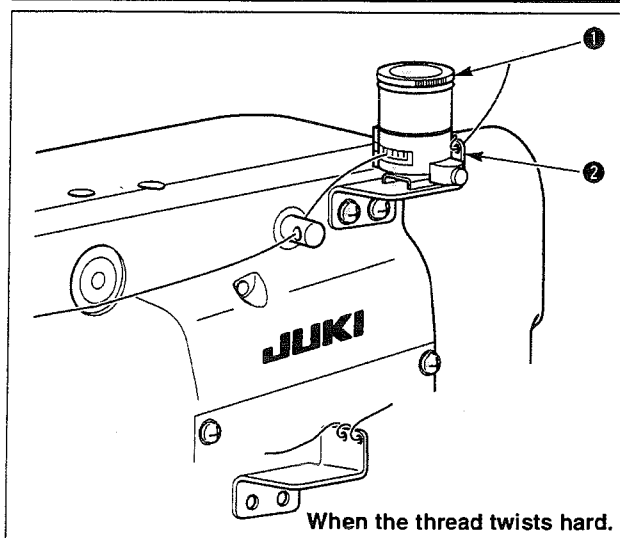

Fix silicon oil tank ❶ (MAXAP30EX00) with the magnet.

(Caution)

If the thread twists hard on silicon oil tank base ❷ (B2535210000), reverse the direction of winding the thread.

3. Connection cord of PK-47



WARNING :

Turn OFF the power before starting the work so as to prevent accidents caused by abrupt start of the sewing machine.

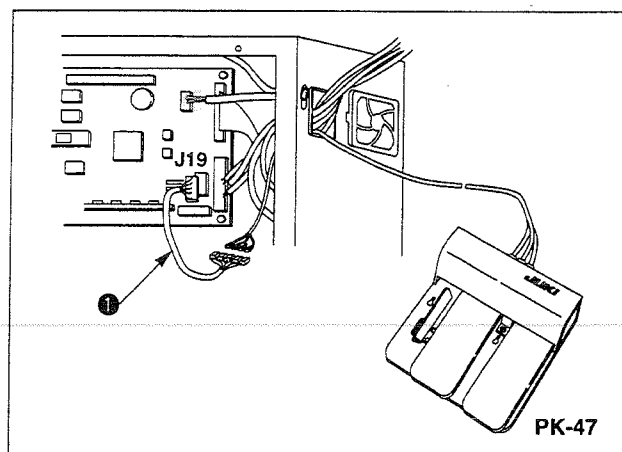

In case PK-47 (GPK470010A0) is used for the foot switch, use pedal switch shifting cable (M90255800A0) ❶.

JUKI®

JUKI CORPORATION
INTERNATIONAL SALES DIVISION
8-2-1, KOKURYO-CHO.
CHOFU-SHI, TOKYO 182, JAPAN
PHONE : 03(3430)4001 ~ 5
FAX : 03(3430)4909 • 4914 • 4984
TELEX : J22967

To order or for further information, please contact :

Please do not hesitate to contact our distributors or agents in your area for further information when necessary.
* The description covered in this instruction manual is subject to change for improvement of the commodity without notice.