

AMB-187N

INSTRUCTION MANUAL
BETRIEBSANLEITUNG
MANUEL D'UTILISATION

MANUAL DE INSTRUCCIONES
MANUALE D'ISTRUZIONI

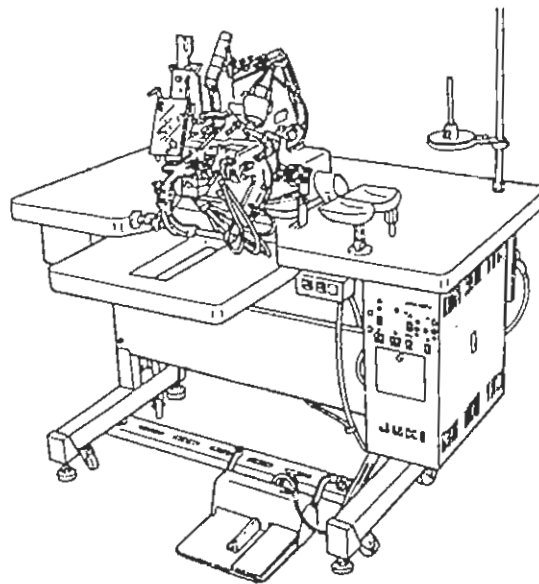

NOTE : Carefully read and understand all safety instructions before beginning use of this machine.
Retain this Instruction Manual for future reference.

HINWEIS : Lesen Sie die Sicherheitsanweisungen aufmerksam durch, um sich mit ihnen vertraut zu machen,
bevor Sie diese Maschine in Betrieb nehmen.
Bewahren Sie diese Bedienungsanleitung für spätere Bezugnahme auf.

NOTE : Avant d'utiliser la machine, lire attentivement toutes les consignes de sécurité.
Conserver ce manuel pour pouvoir le consulter en cas de besoin.

NOTA : Antes de comenzar a usar esta máquina lea con detención hasta comprender todas las instrucciones
de seguridad.
Conserve esta Manual de instrucciones a mano para futuras consultas.

NOTA : Leggere attentamente e comprendere tutte le istruzioni per la sicurezza prima di iniziare l'uso di
questa macchina.
Conservare questo Manuale d'istruzioni per pronto riferimento.



ENGLISH

ENGLISH

Putting sewing systems into operation is prohibited until it has been ascertained that the sewing systems in which these sewing machines will be built into, have conformed with the safety regulations in your country.

Technical service for those sewing systems is also prohibited.

1. Observe the basic safety measures, including, but not limited to the following ones, whenever you use the machine.
2. Read all the instructions, including, but not limited to this Instruction Manual before you use the machine. In addition, keep this Instruction Manual so that you may read it at anytime when necessary.
3. Use the machine after it has been ascertained that it conforms with safety rules/standards valid in your country.
4. All safety devices must be in position when the machine is ready for work or in operation. The operation without the specified safety devices is not allowed.
5. This machine shall be operated by appropriately-trained operators.
6. For your personal protection, we recommend that you wear safety glasses.
7. For the following, turn off the power switch or disconnect the power plug of the machine from the receptacle.
 - 7-1 For threading needle(s), looper, spreader etc. and replacing bobbin.
 - 7-2 For replacing part(s) of needle, presser foot, throat plate, looper, spreader, feed dog, needle guard, folder, cloth guide etc.
 - 7-3 For repair work.
 - 7-4 When leaving the working place or when the working place is unattended.
 - 7-5 When using clutch motors without applying brake, it has to be waited until the motor stopped totally.
8. If you should allow oil, grease, etc. use with the machine and devices to come in contact with your eyes or skin or swallow any of such liquid by mistake, immediately wash the contacted areas and consult a medical doctor.

9. Tampering with the live parts and devices, regardless of whether the machine is powered, is prohibited.
10. Repair, remodeling and adjustment works must only be done by appropriately trained technicians or specially skilled personnel. Only spare parts designated by JUKI can be used for repairs.
11. General maintenance and inspection works have to be done by appropriately trained personnel.
12. Repair and maintenance works of electrical components shall be conducted by qualified electric technicians or under the audit and guidance of specially skilled personnel.

Whenever you find a failure of any of electrical components, immediately stop the machine.
13. Before making repair and maintenance works on the machine equipped with pneumatic parts such as an air cylinder, the air compressor has to be detached from the machine and the compressed air supply has to be cut off. Existing residual air pressure after disconnecting the air compressor from the machine has to be expelled. Exceptions to this are only adjustments and performance checks done by appropriately trained technicians or specially skilled personnel.
14. Periodically clean the machine throughout the period of use.

15. Grounding the machine is always necessary for the normal operation of the machine. The machine has to be operated in an environment that is free from strong noise sources such as high-frequency welder.
16. An appropriate power plug has to be attached to the machine by electric technicians. Power plug has to be connected to a grounded receptacle.

17. The machine is only allowed to be used for the purpose intended. Other used are not allowed.
18. Remodel or modify the machine in accordance with the safety rules/standards while taking all the effective safety measures. JUKI assumes no responsibility for damage caused by remodeling or modification of the machine.

19. Warning hints are marked with the two shown symbols.



Danger of injury to operator or service staff



Items requiring special attention

FOR SAFE OPERATION



1. To avoid electric shock hazards, neither open the cover of the electrical box nor touch any of the components mounted inside the electrical box with the machine energized.



1. To avoid possible personal injuries, be careful not to place your fingers near the area under the work clamp and the needle of the button feeding section when turning ON the power switch and when the machine is in operation.
2. To avoid possible accidents because of abrupt start of the machine, turn OFF the power to the machine when tilting the machine head or removing the belt cover and the V belt.
3. To protect against possible personal injury resulting from being caught in the motor, keep your fingers, hair and clothes away from the driving parts such as handwheel, V belt motor, carriage and stacker and place nothing near those driving parts while the machine is in operation.
4. To avoid personal injury, never operate the machine with any of the belt cover, eye protection cover, or safety devices removed.
5. To avoid possible personal injuries, be careful not to allow your fingers in the machine when tilting/raising the machine head.
6. To avoid electrical shock hazards, never operate the sewing machine with the ground wire for the power supply removed.
7. To prevent possible accidents because of electric shock or damaged electrical component(s), turn OFF the power switch in prior to the connection/disconnection of the power plug.
8. In time of thunder and lightning, stop your work and disconnect the plug from the receptacle for safety's sake so as to prevent possible accidents because of damaged electrical components.
9. If the machine is suddenly moved from a cold place to a warm place, dew condensation may be observed. In this case, turn ON the power to the machine after you have confirmed that there is no danger of water drops in the machine so as to prevent possible accidents arising from damaged electrical component(s).
10. In the event of a power failure, be sure OFF the power to the machine to protect against damaged electrical components.

The sewing machine should rotate away from the operator.

Check for the correct direction of rotation of the sewing machine following the procedure stated below.

- 1) Set the operation mode selector switch to the manual mode.
 - 2) Bring the cloth holder (tongue) to the throat plate.
 - 3) Depress the right-hand side pedal of the 2-pedal unit.
 - 4) Check the direction of the rotation of the sewing machine when depressing the left-hand side pedal of the 2-pedal unit.
2. Make sure that the air pressure gauge indicates 0.5 MPa (0.5 kgf/cm²).

Caution to be taken during operation

1. Before starting button sewing or whenever changing the material or button to be sewn, check the performance of the machine by way of manual operation of the machine and carry out a test sewing taking care of the following points.

① Caution to be taken when changing the type of material to be sewn

- Phenomena such that a too long thread remains on the top face of the button, and such that the thread is likely to come off the material are contrary to each other. In this case, stitch skipping may result. It is therefore necessary to feed first a longer thread and gradually decrease the length of thread to be fed while confirming the finished state of stitches by carrying out trial stitching. (Refer to "3. Adjusting the length of thread remaining" on page 7.)
- When sewing a light-weight material, use the thread presser tongue for light-weight materials so that a uniform length of thread always remain after thread trimming. (Refer to "2. Changing the standard tongue with the thread presser tongue for light-weight materials" on page 19.)

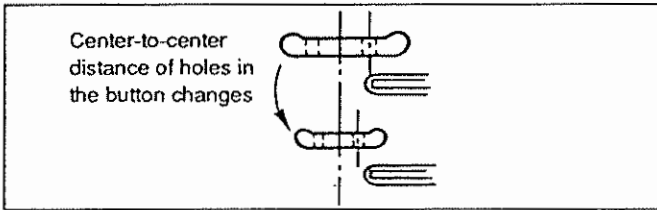

② Caution to be taken when changing the type of button to be sewn

If the center-to-center distance of holes in the button changes, the needle position should be changed. So, adjust the needle position using the knob for adjusting the tie stitch depth. (Refer to "8. Adjusting the depth of tie stitches for sewing flat buttons" on page 16.)

2. Caution to be taken when replacing the button chuck

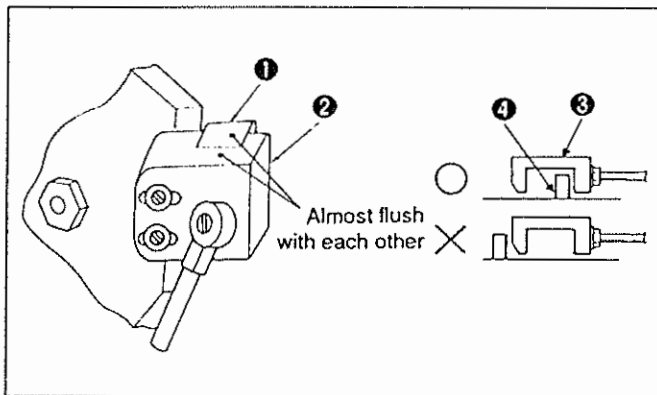

After replacing the button chuck, adjust so that adjusting slide ① is almost flush with button chuck adjusting base ②.

Also confirm that pin ④ fits in lock lever ③.

3. Caution to be taken when using the thread presser tongue

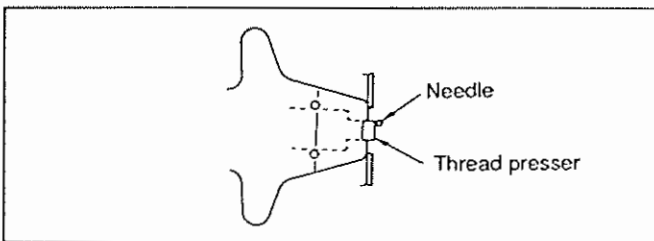

When the thread presser tongue is used with the machine, the thread presser will come in contact with the needle if operating the machine under the "without material" mode. So, be sure to set the switch No. 6 of DIP switches 1 to its OFF position.

4. SCHMETZ SMX332EXTLG #90 needle (Standard)

Use the ORGAN SMx332EXTLG #14BUT (standard) needle for sewing buttons without the button neck.

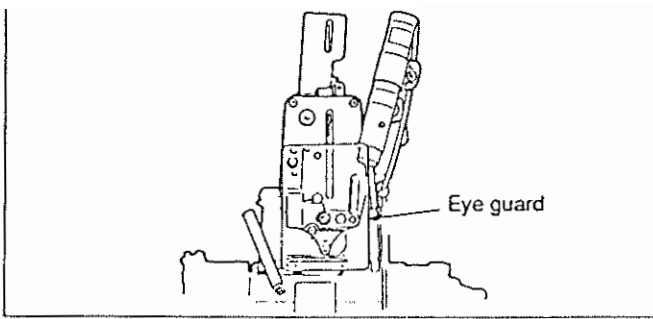

6. During an operation, be careful not to allow your head or fingers or those of any other person to come close to the throat plate or any other driving components.
At the same time, do not place anything close to such components.
7. If any of the following phenomenon occurs, immediately turn OFF the power switch, and ask the maintenance personnel to inspect the machine.
 - ① Frequent needle breakage or thread breakage. The machine often fails to attach the buttons properly.
 - ② The machine performs an unusual operation.
8. Whenever changing the count of thread, re-adjust the timing to release the thread tension. (Refer to "5. Adjusting the timing to release the thread tension" on page 8.)
9. Lubrication
 - ① Lubricated the red-painted points indicated by the arrows in the figure and the hole in the chuck inverting shaft bracket, using JUKI New Defrix Oil No. 1.
 - ② Check whether the oil level reaches the top of the oil felt inside the bed mounting base. If not, supply oil until the oil felt is immersed in oil up to the top.

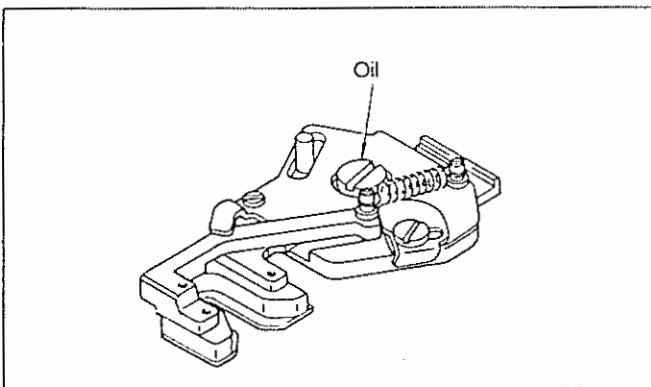
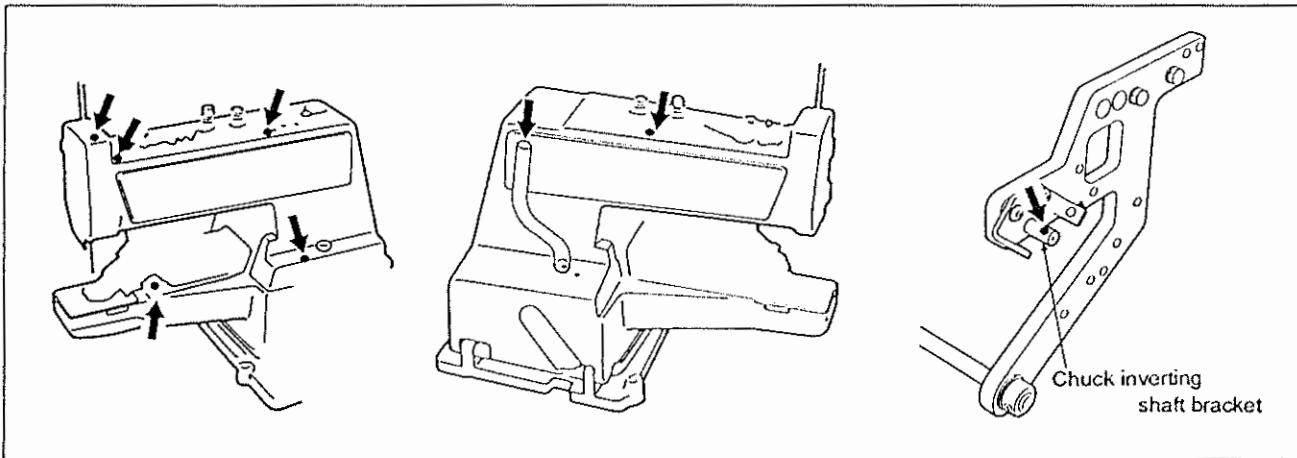

- ③ Apply one drop of JUKI New Defrix Oil No. 1 to the button chuck opening gear approximately once every three months.

10. Do not turn OFF the power and air supply to the sewing machine.

CONTENTS

I. GENERAL	1
1. Features	1
2. Specifications	2
(1) Specifications of the buttons to be used for the AMB-187N	3
3. Configuration	4
II. INSTALLATION	5
1. Attaching the thread stand	5
2. Attaching the table stand components	5
III. OPERATION (Basic information)	6
1. Attaching the needle	6
2. Threading the machine head	6
3. Adjusting the length of thread remaining	7
4. Adjusting the thread tension	8
5. Adjusting the timing to release the thread tension	8
6. Explanation of the panel	9
(1) Explanation of the panel A	9
(2) Explanation of the panel B	10
7. Example of operation of the switches on the control panel	12
(1) Data input	12
(2) Adjusting the origin of button sewing	13
(3) Check the needle entry diagram under the manual operation mode	14
8. Adjusting the depth of tie stitches for sewing flat buttons	16
9. Changing the sewing mode from the 4-holed button to the 2-holed button	17
10. How to replace the button chuck	18
IV. OPERATION (Practical information)	19
1. Adjusting the height of neck wraps for sewing flat buttons	19
2. Changing the standard tongue with the thread presser tongue for light-weight materials	20
3. Changing over the operation mode for sewing buttons without the button neck	21

(1) Adjusting the height of the needle bar	22
(2) Adjusting the position of the needle and that of the loope	22
2. Adjusting the needle and the needle guide	22
3. Adjusting the position of the yoke slide	23
4. Adjusting the clearance between the needle and the throat plate	24
5. Replacing the moving knife	24
VI. LIST OF ERROR CODE	25
VII. AIR PIPING DIAGRAM	27
VIII. LIST OF OPTIONAL PARTS	28
IX. INSTALLATION OF THE BUTTON LOADER	29
1. Parts and names of parts	29
2. Assembling procedure	30
3. How to adjust the button loader	32
4. How to operate each item	35
5. Precautions to be taken	36
6. Explanation of the panel	37

I. GENERAL

1. Features

1. The machine is easily adapted to changes in button size.

The machine is equipped with button chucks for $\phi 8$ to $\phi 16$, $\phi 14$ to $\phi 25$ and $\phi 21$ to $\phi 32$ buttons. The button chucks can be replaced only by operating the lock lever without using a tool to allow a woman operator to easily replace the button chuck.

2. The sewing machine has a wider application range.

The machine can be widely used to attach buttons on light-weight garments such as blouses to medium-weight garments such as jackets. Neck wrap height can be set to 0 (zero) or 2.5 to 6 mm. This also helps allow the machine to adapt to wide-ranging specifications.

3. The machine finishes high-quality seam.

By combining highly-reliable machine head and JUKI's unique X-Y control, the machine can sew buttons while achieving well-feeling and high-quality seam. Furthermore, the machine can sew reinforcing stitches thereby preventing the thread from fraying.

4. Reduced cycle time enhances productivity.

The sewing speed is as high as 850 s.p.m., thereby reducing the machine time. Cycle time is also reduced by a marker lamp that facilitates positioning of a button, button setting mechanism which allows the operator to set a button in position by single hand and the cloth setting tongue which automatically opens. This means that the machine ensures a higher degree of productivity.

5. The machine does not need an exclusive thread.

This machine does not use its exclusive thread but use many different types of thread including cotton thread and spun thread. Wider selection of thread colors is possible. The threads of count #30 through #60 are applicable to the machine, thereby allowing the machine to be used in wider variety of processes.

6. It flexibly corresponds to variable types of sewing production line

It is equipped with casters as standard device. They help move the machine with ease, thereby facilitating lay-out changing. Since the adjustable range of the machine height is possible, the machine can be introduced to the setting operation line as well as the standing operation line.

2. Specifications

Model :	AMB-187N
Name:	Computer-controlled, single-thread chainstitch, button neck wrapping machine
Stitch system :	Single-thread chainstitch
Application and features :	Sewing buttons with neck wraps and flat buttons without neck wraps on men's wear, tops of ladies' wear, vests and coats
Sewing speed :	850 spm
Needle bar stroke :	58.6 mm
Needle with neck wraps :	With neck wraps: SCHMETZ SMX332EXTCG, standard #90 (#80, #100)
Needle without neck wraps :	Without neck wraps: ORGAN SMX332ETLG, standard #14 BOT (#16, #18)
Thread :	Cotton thread.. #30 to #60 Spun thread .. #30 to #60
Lubrication :	Manual
Outside diameter of button :	$\phi 8$ to $\phi 16$ mm (button chuck, small), $\phi 14$ to $\phi 25$ (button chuck, medium) and $\phi 21$ to $\phi 32$ (button chuck, large)
Number of stitches :	2 to 30 in 2-stitch steps
Number of neck wraps :	0 to 44 stitches in 2-stitch steps If the number of stitches exceeds 16, the set value is specified in 4-stitch steps.
Distance from the material to the button (Height of the button neck):	2.5 to 6 mm, When the indicator shows 0 (zero), buttons are sewn without neck wraps.
Number of stay stitches :	1 or 2

Neck wrapping position :	Determined in accordance with the starting position and the highest position of neck wrapping
Buttonhole (X, Y) pitch :	X=2 to 5 mm Y=2 to 5 mm To be set in increments of 0.2 mm
Stitch width of the neck wrap :	0 to 3 mm from the center of the button hole toward either end in increments of 0.2 mm
Production capacity :	1,843 buttons/8 hrs.
Power supply :	Single-phase, 100V, 110V, 120V, 200V, 220V, 240V 3-phase, 200V, 220V, 240V, 380V, 415V, 440V
Power consumption :	300W
Compressed air :	0.5 MPa {0.5 kgf/cm ² }
Air consumption :	15 ℓ /min.
Dimensions :	1,110 mm (W) x 810 mm (D) Table height, 750 - 1,030 mm
Weight :	120 kg

Noise : Workplace-related noise at sewing speed

$n = 600 \text{ min}^{-1} : L_{PA} \leq 73.5 \text{ dB(A)}$

Noise measurement according to DIN 45635-48-B-1.

(1) Specifications of the buttons to be used for the AMB-187N

★ (Specifications for 4-holed button and 2-holed button)

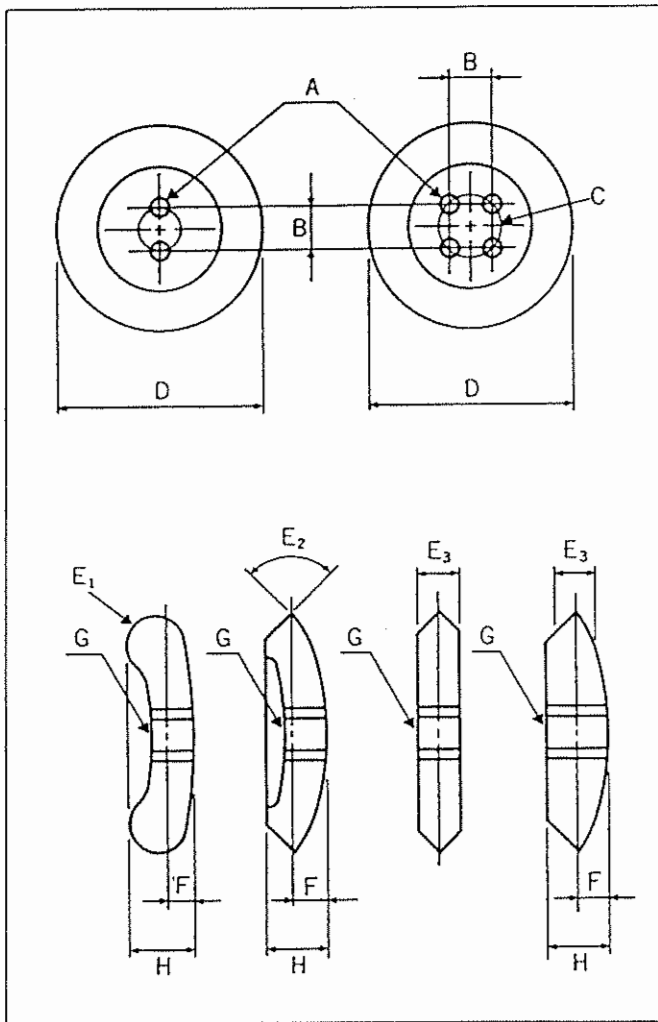

A. Button hole diameter

Needle: For #12 to #16 needles, $\phi 1.5$ mm or more

Needle: For #12 to #18 needles, $\phi 2$ mm or more

B. Distance between the button holes

2 to 5 mm

C. Button holes

All holes must be located equidistantly from the center of each button.

D. Outside diameter

Min. 8 mm

Max. 32 mm

Line size ± 0.25 mm or less

E1. Button with a round edge

The button must have a radius of 3 mm or less.

E2. Button with a V-shaped edge

Within 120°

E3. Button with an angular edge

The thickness must be 5 mm or less.

F. Bulge

5 mm or less

G. Area around the holes

Must be smooth

H. Thickness

8 mm or less

(Caution) If the button loader (optional) is used with the sewing machine, shank buttons or marble buttons cannot be sewn in accordance with the shape of buttons.

This is a Computer-controlled, single-thread chainstitch, button neck wrapping machine intended to be used to sew buttons on men's wear, vests, ladies' wear, blazer coats and skirts. It allows the operator to attach buttons in one operation cycle consisting of the 1st and 2nd neck wrapping processes only by pressing the start switch after the buttons and the garment cloth have been set in the predetermined location on the machine.

It is a very convenient machine since it has been designed also to sew buttons without neck wraps and to permit easy selection of sewing pattern using the switch.

The following shows the main components of the AMB-187N.

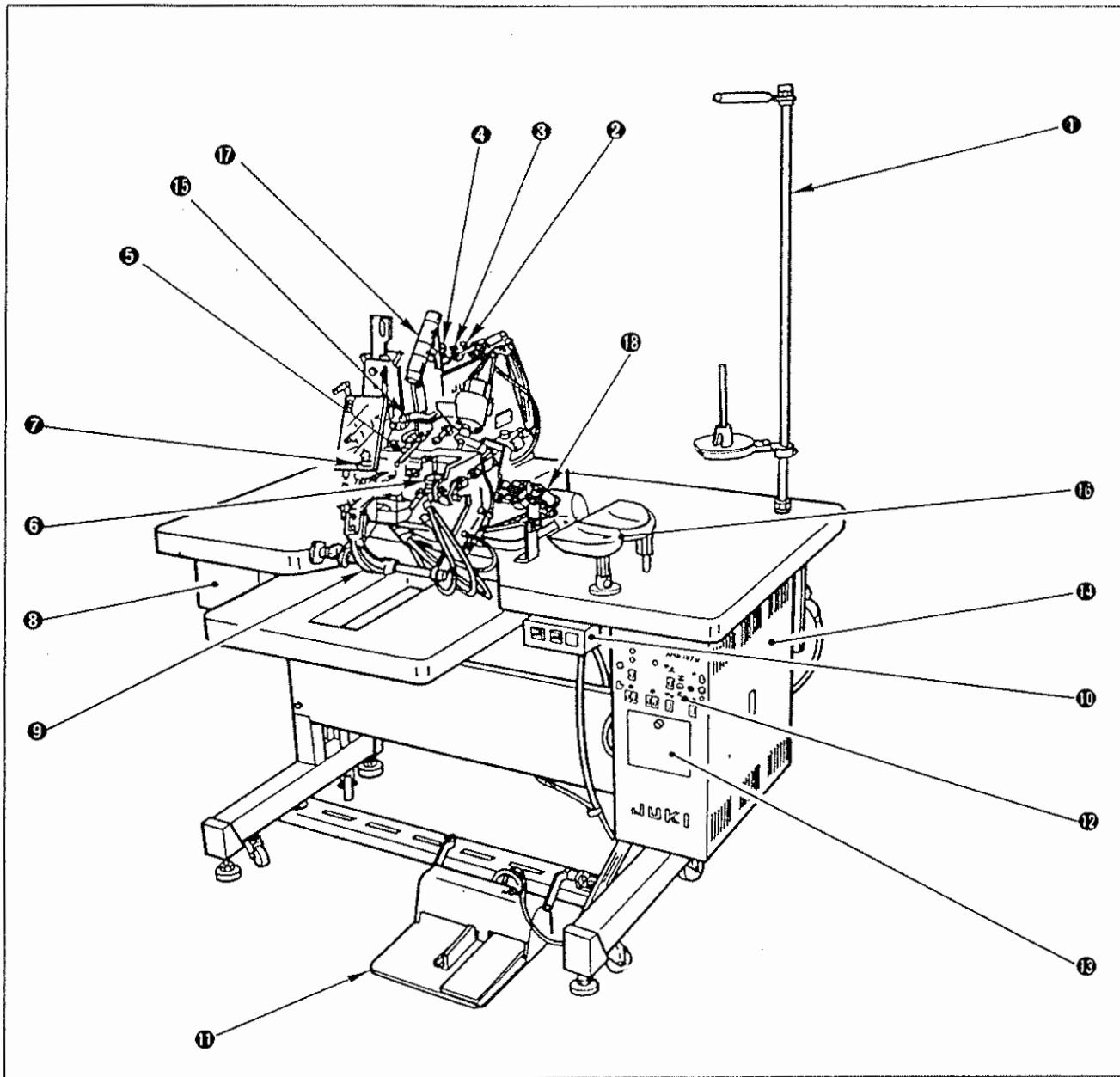

- | | | |
|---|-----------------------------------|----------------------------|
| ① Thread stand | ⑦ Material tucking depth actuator | ⑮ Temporary stop switch |
| ② Thread tensioner No. 1
(for neck wrapping) | ⑧ Drawer | ⑯ Button tray |
| ③ Thread tensioner No. 1
(for button sewing) | ⑨ Cloth holder (tongue) | ⑰ Marking lamp |
| ④ Thread tensioner No. 2 | ⑩ Power switch | ⑱ Button loader (optional) |
| ⑤ Wiper | ⑪ 2-pedal unit (PK62) | |
| ⑥ Knob to adjust neck wrap height | ⑫ Operation panel A | |
| | ⑬ Operation panel B | |
| | ⑭ Control box | |

II. INSTALLATION

1. Attaching the thread stand

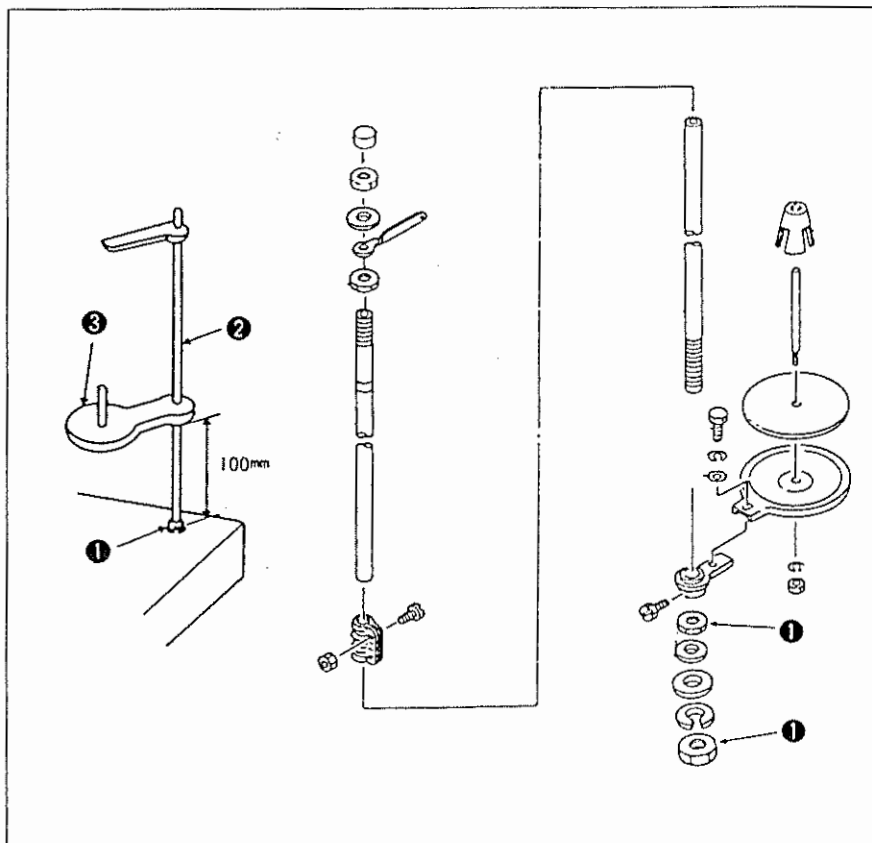

Assemble the thread stand, and put it in the hole in the right corner of the machine table.

Set the height of ③ to approximately 100 mm.

Tighten locknut ① to securely fix the thread stand. When ceiling wiring is possible, pass the power cable through spool rest rod ②.

2. Attaching the table stand components

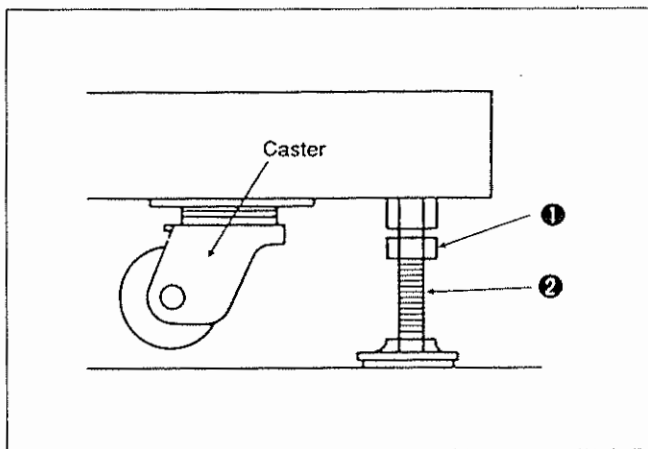

To ensure that the machine operates properly, it is necessary to set up the sewing machine on a flat surface free from vibration.

[How to adjust the machine so that it is level]

Loosen four locknuts ① installed on the bottom of the main unit, and turn adjustment bolts ② to level the whole machine. After adjusting the machine so that it is level, be sure to tighten up the locknuts.

1. Attaching the needle



WARNING:

Turn OFF the power before starting the work so as to prevent accidents caused by abrupt start of the sewing machine.

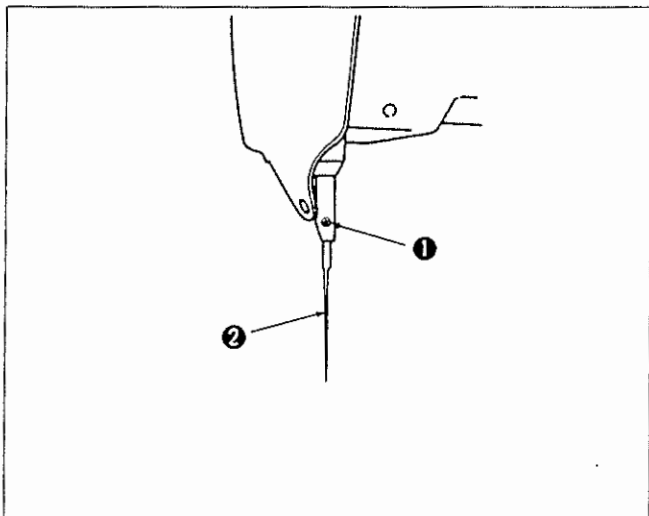

- 1) Loosen screw ①, and hold needle ② with its long groove faced toward you.
- 2) Insert needle ② until the top of the needle hole in the needle bar is reached.
- 3) Securely tighten screw ①.

The standard needle to be used is:

ORGAN SM×332EXTLG #14 needle for sewing buttons with the button neck

ORGAN SM×332EXTLG #14BUT needle for sewing buttons without the button neck

- (Caution)
1. Turn OFF the power to the motor.
 2. When sewing buttons without the button neck, operate the sewing machine with the button chuck removed.
 3. To sew a medium-weight material, use a needle of which needle count is #14 or higher.

2. Threading the machine head



WARNING:

Turn OFF the power before starting the work so as to prevent accidents caused by abrupt start of the sewing machine.

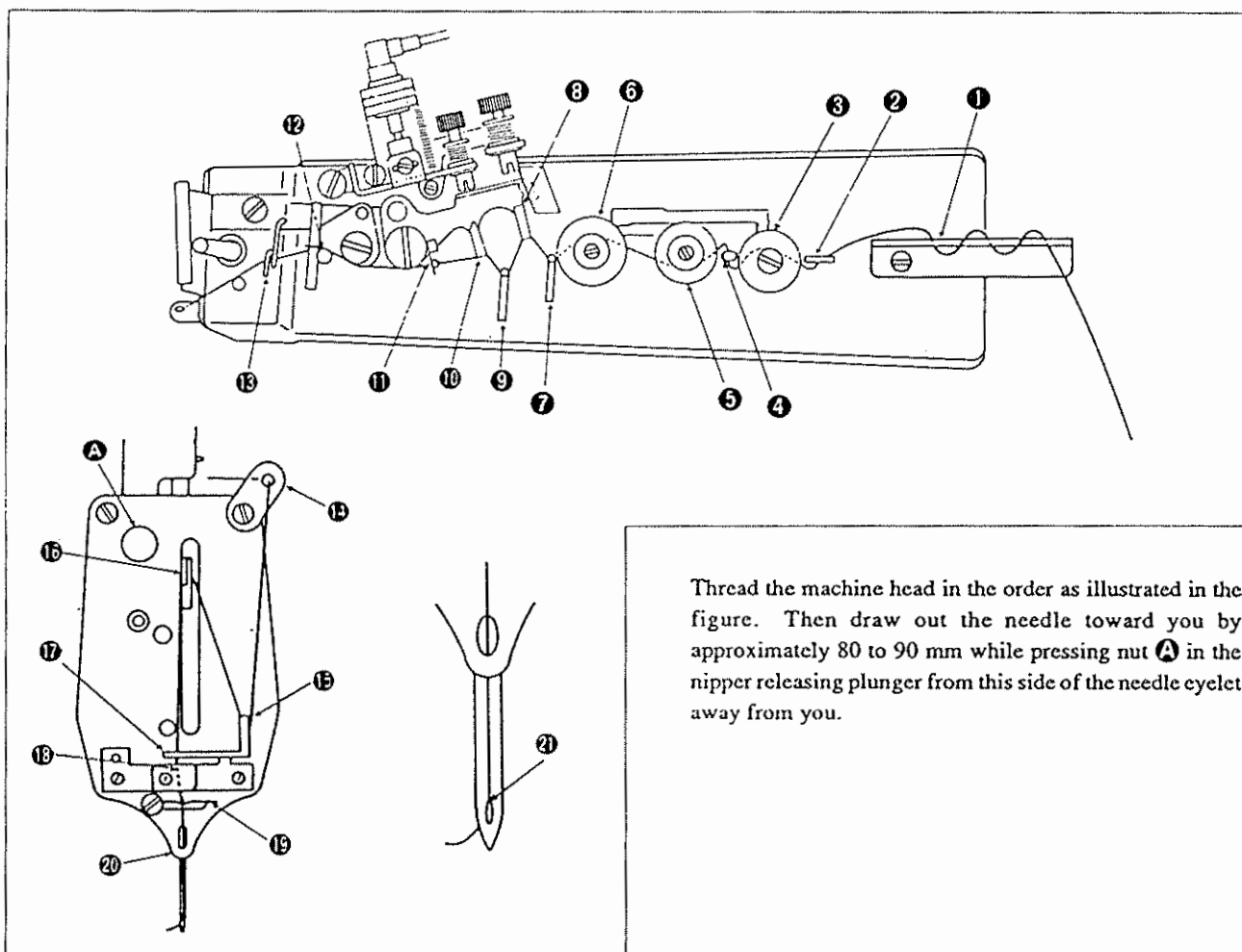



Thread the machine head in the order as illustrated in the figure. Then draw out the needle toward you by approximately 80 to 90 mm while pressing nut A in the nipper releasing plunger from this side of the needle eyelet away from you.

3. Adjusting the length of thread remaining

WARNING:
 Turn OFF the power before starting the work so as to prevent accidents caused by abrupt start of the sewing machine.

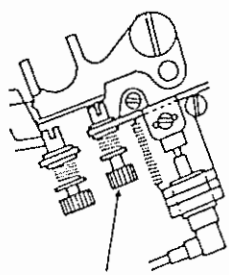
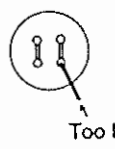
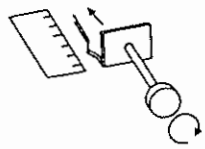
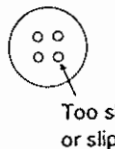
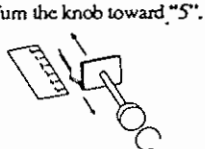
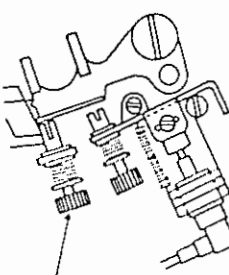
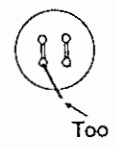
Adjust the length of thread remaining following the procedure described below.

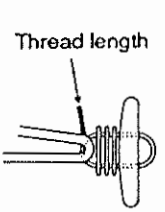
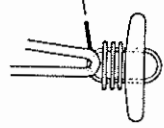
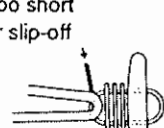
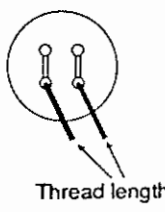
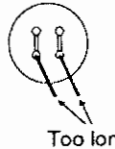
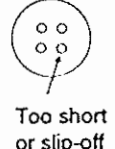
Sewing specification	Part to be adjusted	Related knob and its adjustment	Troubles and corrective measures	
			Trouble	Corrective measure
With neck wraps	Right-hand side button holes	 Adjust the length of the remaining thread using knob ①.	 Too long	 Turn the knob toward "0".
			 Too short or slip-off	 Turn the knob toward "5".
	Left-hand side button holes	 Adjust the length of the remaining thread using knob ②.	 Too long	Turn the knob toward "0".
			 Too short or slip-off	Turn the knob toward "5".
	First stitch of neck wraps	 Adjust the length of the remaining thread using knob ②.	 Too long	Turn the knob toward "0".
			 Too short or slip-off	Turn the knob toward "5".
Without the button neck	 Adjust the length of the remaining thread using knob ②.	 Too long	Turn the knob toward "0".	
		 Too short or slip-off	Turn the knob toward "5".	

**WARNING:**

Turn OFF the power before starting the work so as to prevent accidents caused by abrupt start of the sewing machine.

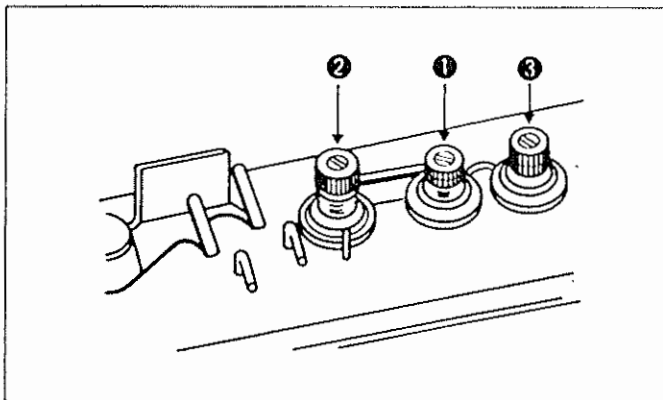

Name of thread tension	No.	Process	Function
Tension adjustment nut No. 1 for button sewing	①	First process of button sewing	Used to adjust the thread tension for button sewing.
Tension adjustment nut No. 1 for neck wrapping	③	Second process of button sewing	Used to adjust the thread tension for button neck wrapping.
Tension adjustment nut No. 2.	②	First and second processes for button sewing	Used to adjust the tension of the thread sewn on the wrong side of the material for button sewing and button neck wrapping.

- Turning each adjustment nut clockwise will increase the thread tension or counterclockwise will decrease it.
- The tension adjustment nut No. 2 is capable of adjusting the thread tension to higher value than the tension adjustment nut No. 1 and it needs to be adjusted in accordance with the thread, material or thickness of the button to be used.

5. Adjusting the timing to release the thread tension**WARNING:**

Turn OFF the power before starting the work so as to prevent accidents caused by abrupt start of the sewing machine.

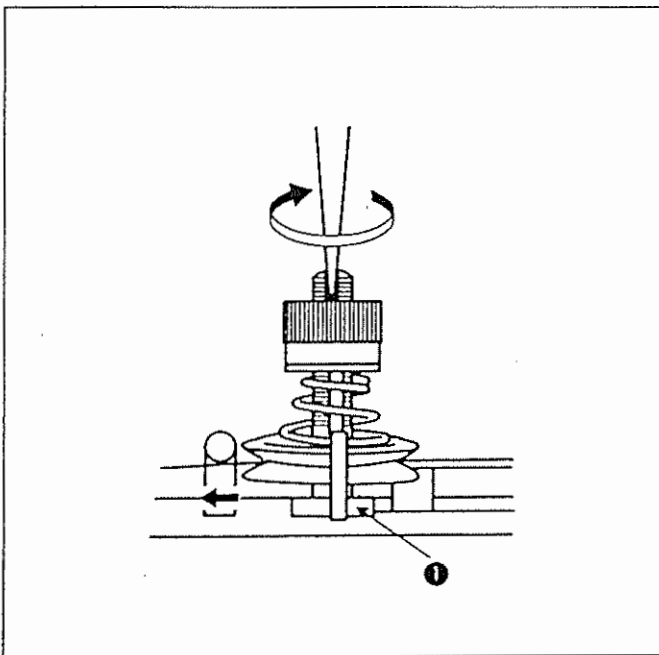

Pulling the thread in the direction of the arrow, turn the handwheel until you find the position where the thread tension disk No. 2 comes up to allow the thread to draw out. At this time, the standard distance of 49 to 52 mm should be provided between the surface of the needle bar upper bushing and the top end of the needle. The below-stated adjustment is necessary especially when the following phenomenon frequently occur.

Loosen nut ①. Fit a screwdriver into the thread tension rod, and turn it in the direction of the arrow to lower the needle bar or in the opposite direction of the arrow to raise the needle bar.

Phenomenon and change of thread	Height of the needle bar
1) Loose stitches are observed on the wrong side of the material	Slightly raise the needle bar.
2) Thread breakage frequently occur.	Slightly lower the needle bar.
3) When the thread is changed for thicker one.	Slightly lower the needle bar.

6. Explanation of the panel

(1) Explanation of the operation panel A



CAUTION:

To avoid possible accidents due to abrupt start of the machine, never place your feet or any other thing near the start switch.

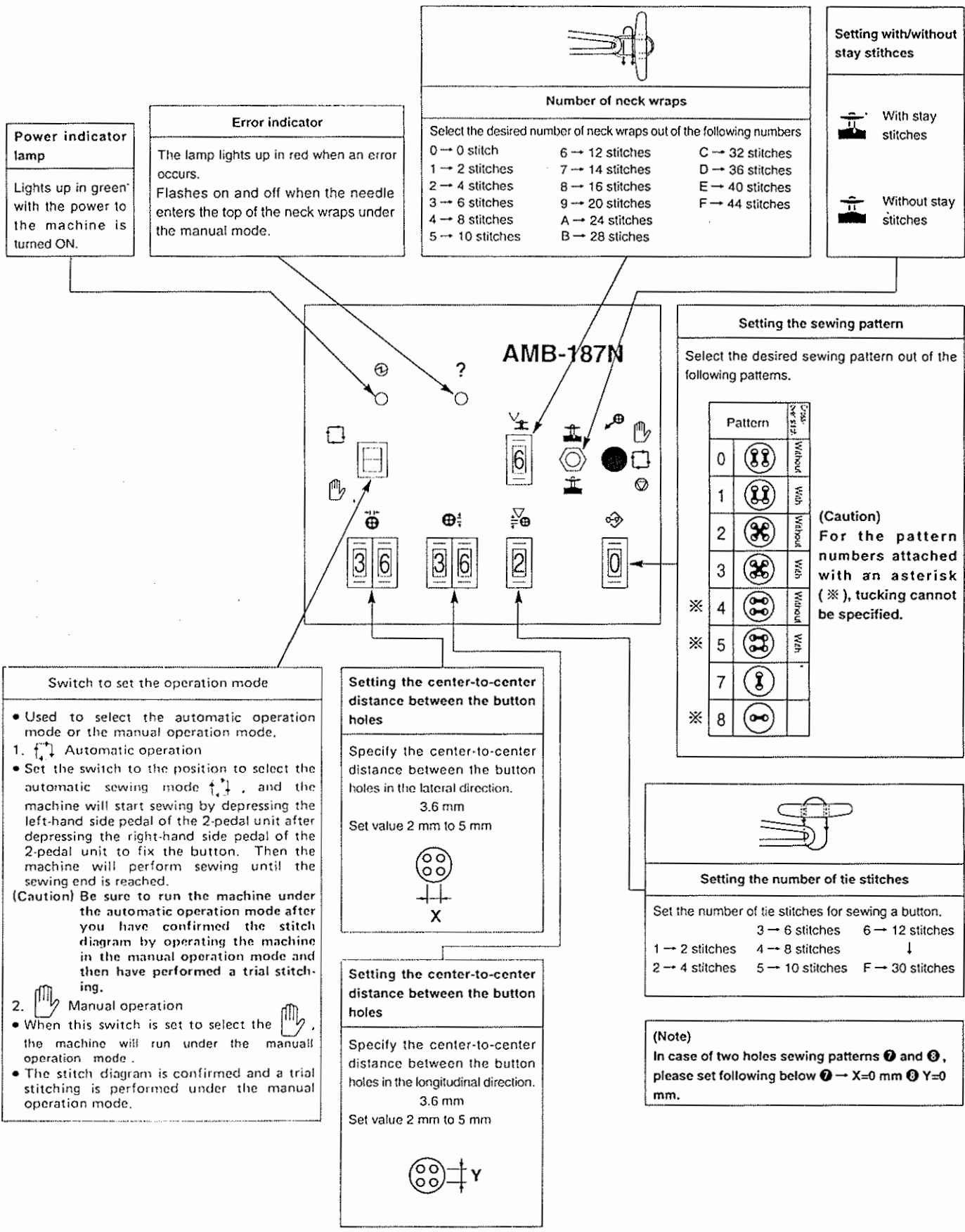

**CAUTION:**

To avoid possible accidents due to abrupt start of the machine, never place your feet or any other thing near the start switch.

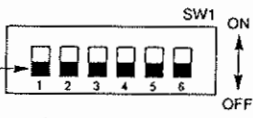
DIP switch 1

(at the time of delivery)

These are the switches.

Number of stay stitches No. 1

Used to specify the number of stay stitches.

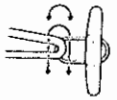

1 stitch	OFF
2 stitches	ON

Number of first stitches for neck wrapping No. 2

Used to specify the number of stitches to be made on the material in the first process of neck wrapping.



1 stitch	OFF
2 stitches	ON

Number of tie stitches No.3

Used to specify the number of tie stitches.

2 stitches	OFF
3 stitches	ON

Used to specify the location of tie stitches No. 4

Used to specify the location of tie stitches in the neck wrapping process.

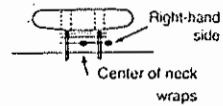

Center of neck wraps	OFF
Right-hand side	ON

No. 5

Stitch system selection

Sewing buttons with the button neck	ON
Sewing buttons without the button neck	OFF

No. 6

Specifies with/without the thread presser.
* Use the thread presser when sewing a light-weight material.

Without thread presser	OFF
With thread presser	ON

Setting the start position of neck wrapping SW4

To move the start position of neck wrapping toward the cloth, set the switch to a smaller value. On the contrary, set the switch to a larger value to move the start position of neck wrapping toward the button. The moving amount of the start position is specified in increments of 0.2 mm.

The center of the button is the reference for setting of the start position of neck wrapping.

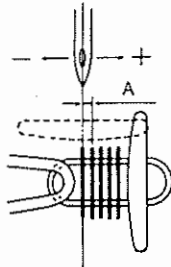

Scale	Distance A
0	-0.6 mm
1	-0.4 mm
2	-0.2 mm
3	0 mm
...	...
14	2.2 mm
15	2.4 mm

Adjusting the origin in the X direction SW2

The position of the origin with respect to the X direction is finely adjusted by using this switch.

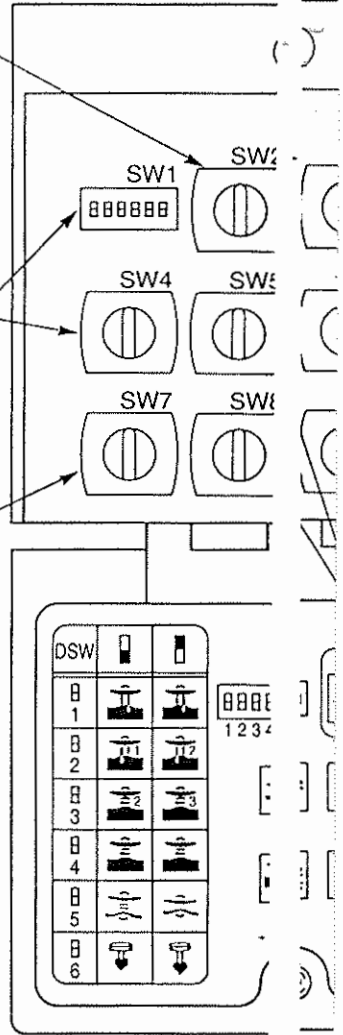
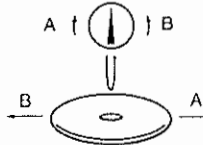
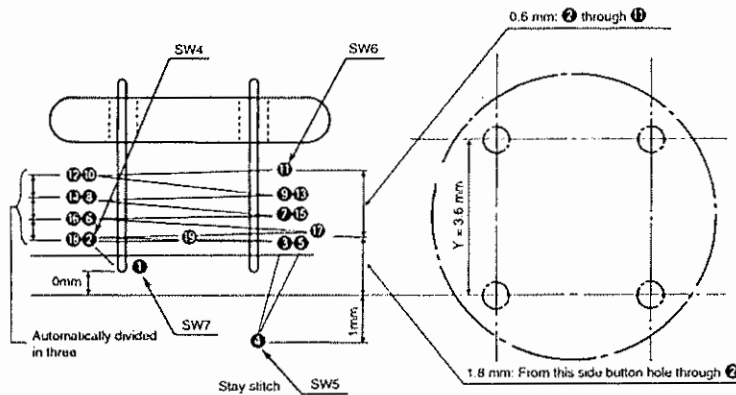
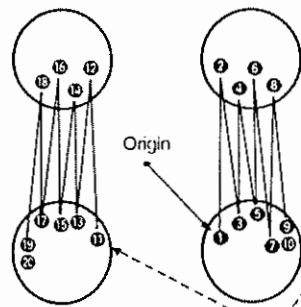
**1. With neck wraps****2. Without neck wraps**

Pattern No.0

Setting the needle entry point for the first stitch of neck wraps SW7

The needle entry point can be specified from the button sewing position toward the button within the range of -1~+2 mm in increments of 0.2 mm.

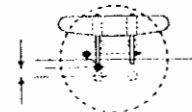

This data is necessary to align the needle entry on the material in the 1st process.

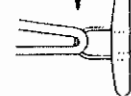

Adjusting the origin in the Y direction SW3

The position of the origin with respect to the Y direction is finely adjusted by using this switch.

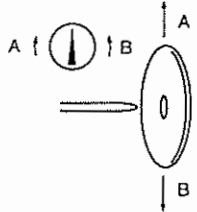

Indicator of error code/number of stitches LD1

- This LED indicates the error code or the specified values of the number of the stitches and the number of neck wraps.
- Since the LED only indicates the number of single digit, it shows the number in turn. For "AL13" It indicates as "A → [4] → [0] → [1] → [3]" while flashing on and off. For "8 tie stitches and 16 neck wraps" It indicates as "[8] → [0] → [1] → [6]" while flashing on and off.
- It repeats indicating the number of tie stitches and the number of neck wraps three times after the relevant data changing.

Setting the highest position of the neck wraps SW6

To move the highest position of the neck wraps to the cloth, set the switch to a larger value. On the contrary, set the switch to a smaller value to move the highest position of the neck wraps to the button. The moving amount is specified in increments of 0.2 mm. Note that this setting is permitted only when the knob to adjust the neck wrap height is set to 2.5 on the scale. The center of the button is the reference for setting. Increasing the neck wrap height will automatically increase value A.

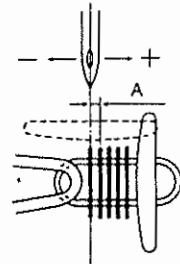

Scale	Distance A
0	→ 1.5 mm
1	→ 1.3 mm
2	→ 1.1 mm
3	→ 0.9 mm
...	
14	→ -1.3 mm
15	→ -1.5 mm

Setting the number of revolutions of the sewing machine VR1

Specifies the number of revolutions of the sewing machine. 200 to 850 s.p.m.

Reset switch SW10

This switch is pressed to reset the machine to the normal operation mode after correcting an error.

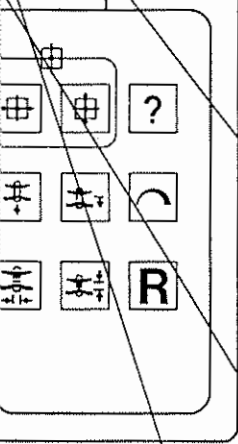
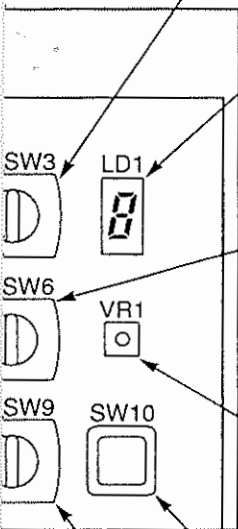

Setting the location of tie stitches SW9

Used to specify the location of tie stitches

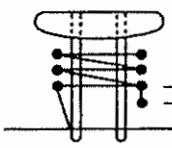

The location of tie stitches (the last stitch) can be specified within the range of -1 ~ +2 mm in increments of 0.2 mm toward the material.

Adjust so that a clearance of 0.1 to 0.3 mm is provided between the material and the needle.

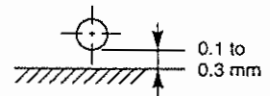

Setting the location of the stay stitch SW5

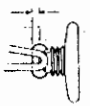

The location of the stay stitch can be specified from the button hole toward the cloth within the range of 0 to 3

Setting the stitch width for neck wrapping SW8

4-holed button
The stitch width is specified from the center to either end of the button within the range of 0 to 3 mm in increments of 0.2 mm (max. stitch width 8 mm).

2-holed button
The stitch width is specified from the center to either end of the button within the range of 0 to 3 mm in increments of 0.2 mm (max. stitch width 8 mm).



CAUTION:

To avoid possible accidents due to abrupt start of the machine, never place your feet or any other thing near the start switch.

(Example of sewing specification)

4-holed button, parallel stitching, without cross-over stitch, with neck wrap stitches, 8 tie stitches, 14 neck wraps, 1 reinforcing stitch, 1 stay stitch

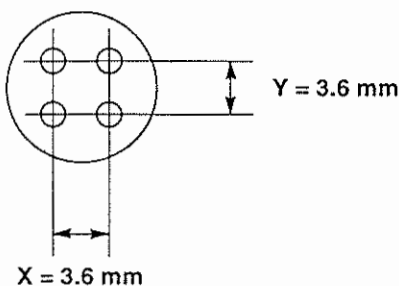

(1) Data input

Panel	Item	Switch	Data	Panel operation
Control panel A	a) Sewing pattern			Set to "0".
	b) Number of tie stitches		8 stitches	Set to "4".
	c) Number of neck wraps		14 stitches	Set to "7".
	d) Center-to-center distance X between the button holes		3.6 mm	Set to "36".
	e) Center-to-center distance Y between the button holes		3.6 mm	Set to "36".
Control panel B	g) With/without stay stitches		With stay stitches	Set the switch to its upper position.
	h) Number of stay stitches	DIP SW1 No. 1	1 stitch	Set the switch No. 1 to its lower position.
	i) Number of last stitches for button sewing	DIP SW1 No. 2	1 stitch	Set the switch No. 2 to its lower position.
	j) Stitch width for neck wrapping	SW8	5.2 mm	Set the switches to "4".
	k) Location of the stay stitch	SW5	1.0 mm away from this side buttonhole	Set the switch to "5".
	l) Number of revolutions of the sewing machine	VR1	850 s.p.m.	Turn the dial clockwise until it will go no further.

Panel	Item	Switch	Data	Panel operation
Control panel B	m) Start position of neck wrapping	SW4	Starts from the center of the button	Set the switch to "3".
	n) The highest position of the neck wraps	SW6	0.9 mm above the center of the button	Set the switch to "7".
	o) The position of the first stitch for neck wrapping	SW7	0.4 mm away from this side button hole	Set the switch to "0".
Knob	p) Height of the neck wraps	Knob to adjust the neck wrap height	Neck wrap height is set to 3 mm (reference).	Set the knob to "3".
	q) Depth of tie stitches	Knob to adjust the thrusting amount	Position of this side button hole	Set the knob to "0".

(Caution) 1. The actual values of switches and knobs j), k), l), m), n), o), p) and q) may change in accordance with the thickness of the material to be used. Consequently, the switches and knobs stated above should be adjusted by performing trial stitching by way of manual operation.

2. If distance a exceeds 1 mm at the time of chucking the button, the exceeding amount should be added to the scale value of 2.5 which indicates the neck wrap height so as to raise the highest position of the neck wraps.

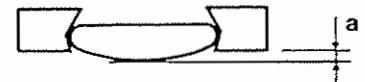

(The highest position of the neck wraps should be adjusted using the SW6, in this case, since the button comes in contact with the throat plate.)

3. Adjust position o) in accordance with the type of the material and the pulling force applied to the material toward the button at the time of neck wrapping.

(2) Adjusting the origin of button sewing

Insert the master button to the chuck and adjust the position of the button with respect to the needle of the sewing machine.

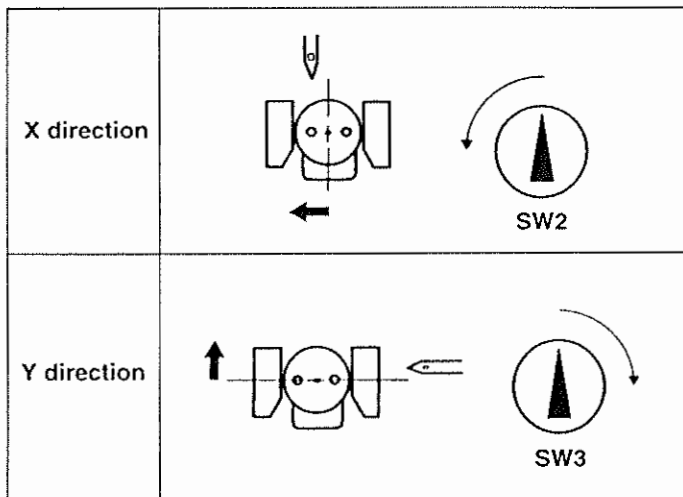

**CAUTION:**

Keep your fingers/hands away from the moving parts since manual operation might give rise to involvement and injury from the needle.

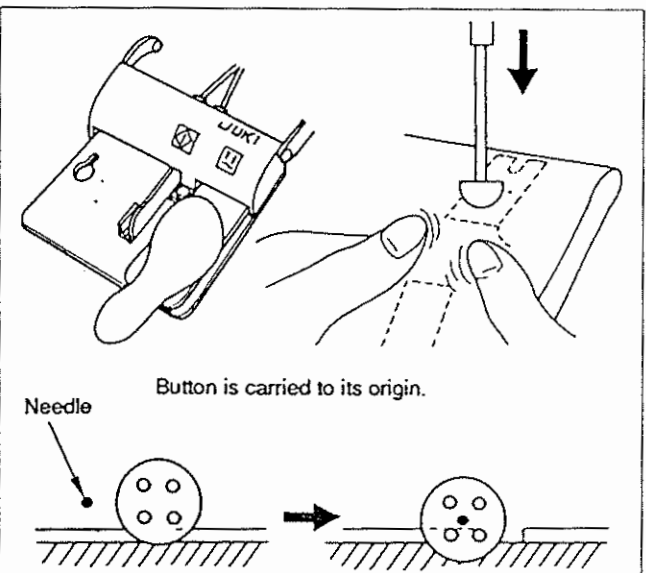
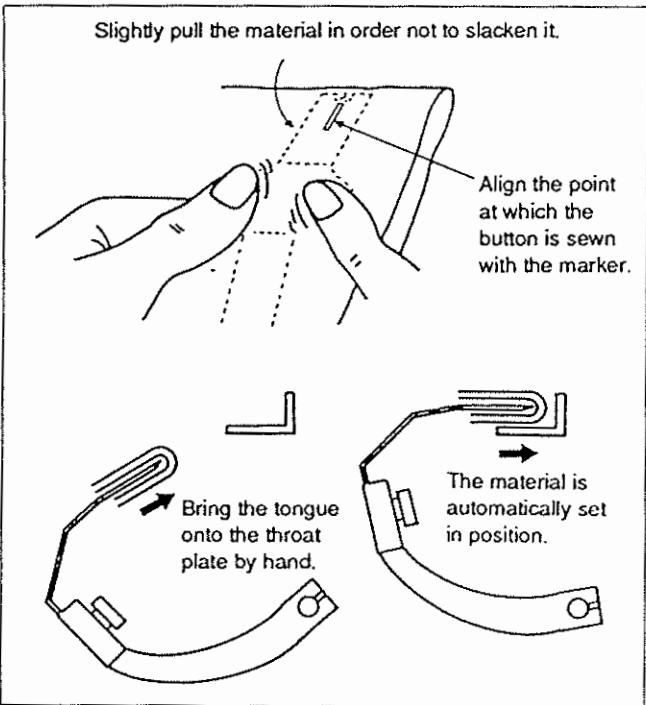
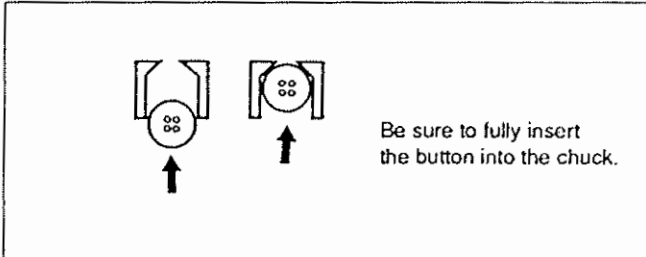
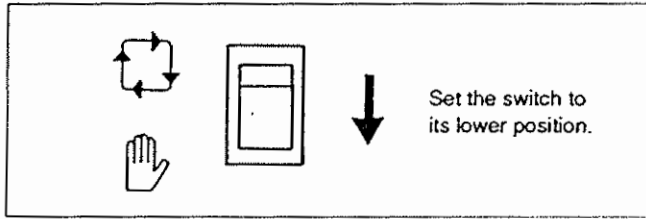

1) Specify the manual mode using the selector switch mounted on the operation panel A.

2) Insert the button in position.

3) Set the material on the tongue.

- When the tongue on which the material is set is brought onto the throat plate, the air may be automatically actuated to set the material in position on the throat plate.
- Once the material is set in position, take care not to apply external load to the tongue.

4) Depress the right-hand side pedal of the 2-pedal unit, then the following operation will be automatically carried out.

- The chuck fixes the button.
- The work clamp actuates.
- The button is brought to the origin.
(Depress the pedal again, and the machine will be reset.)

(Caution) Take care not to allow your hand to come in contact with the work clamp.

Button sewing process

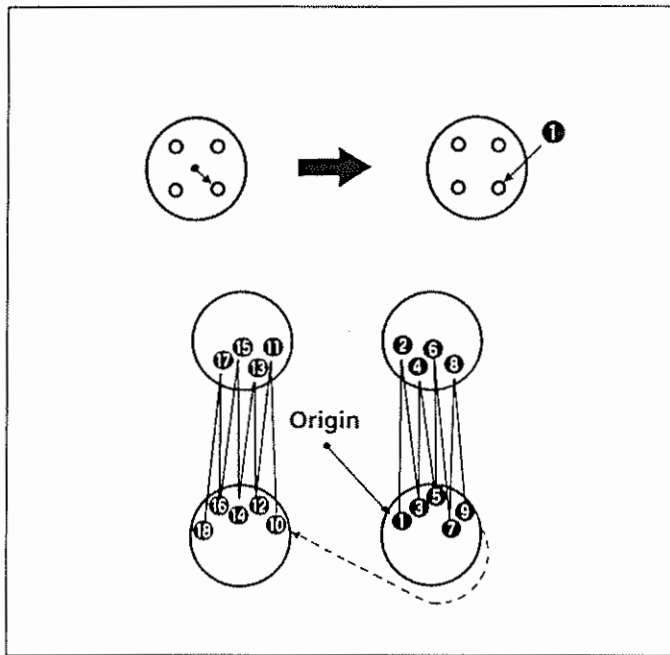

- 5) Depress the left-hand side pedal of the 2-pedal unit, the following operation will be carried out automatically.
 - The button moves to the origin to the tucking position (the first stitch).
- 6) Every time you depress the left-hand side pedal of the 2-pedal unit, the button will move stitch by stitch from the needle entry ② to needle entry ⑱. The machine performs the above-stated procedure by turning the handwheel of the sewing machine by hand.

Neck wrapping process

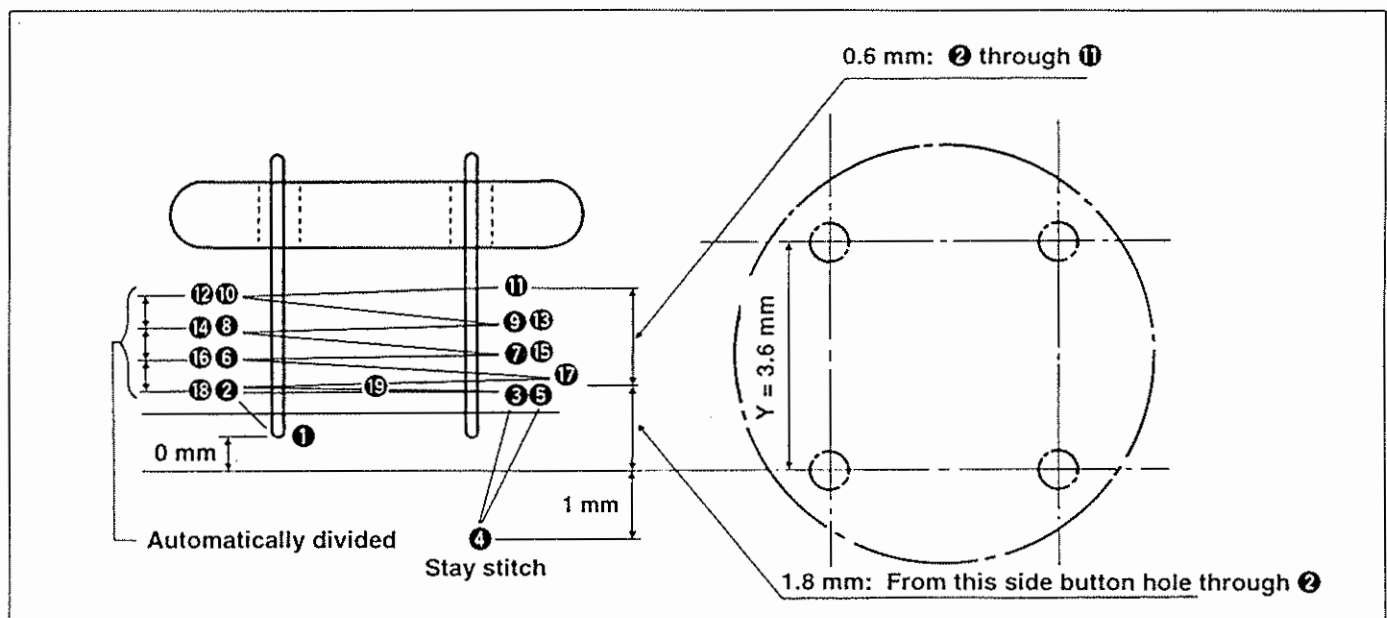

- 7) Kick the left-hand side pedal of the two-pedal unit, and the chuck will be inverted.
- 8) Every time you depress the left-hand side pedal of the 2-pedal unit, the button will move stitch by stitch from the needle entry ① to needle entry ⑱. The machine performs the above-stated procedure by turning the handwheel of the sewing machine by hand.
- 9) Depress the left-hand side pedal, and the thread trimmer will be automatically actuated.
- 10) Depress the left-hand side pedal of the 2-pedal unit, the following operation will be carried out automatically.
 - The work clamp returns to the home position.
 - The chuck is released.
 - The tongue is released.

**CAUTION:**

Keep your fingers/hands away from the moving parts since manual operation might give rise to involvement and injury from the needle.

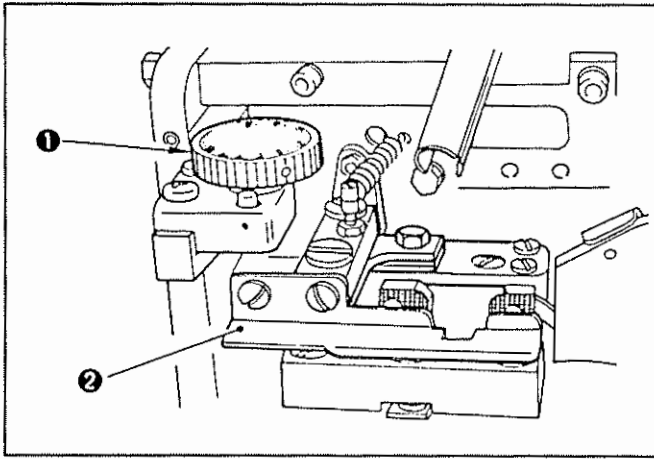

1) Adjust the depth of tie stitches by turning regulating knob

1.Turn the knob clockwise, and work clamp, lower **2** will move away from the needle to decrease the depth of tie stitches. Turn the knob counterclockwise, and it will approach the needle to increase it.

←	→
4 · 2 · 0 · -2 · -4	4 · 2 · 0 · -2 · -4
Depth of tie stitches increases	Depth of tie stitches decreases

- Relation between the depth of tie stitches and the scale
The work clamp, lower moves 0.07 mm for one division of the scale.

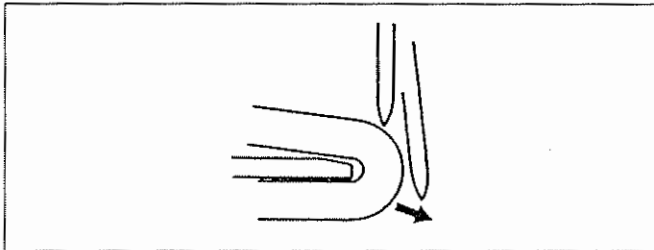

(Caution) The needle may likely to fail to catch the stiff material. So, when using such a material, increase the depth of tie stitches.

9. Changing the sewing mode from the 4-holed button to the 2-holed button



WARNING :

Turn OFF the power before starting the work so as to prevent accidents caused by abrupt start of the sewing machine.



When changing the sewing mode from the 4-holed button to the 2-holed button, carry out the following operation.

No.	Item	Sketch
1	Loosen knob ② which fixes tongue ① in place, and replace the tongue for 4-holed buttons with the tongue for 2-holed buttons.	
2	Change the data, and confirm the data entered. a) Change the sewing pattern. b) Specify the center-to-center distance between the holes into the button. c) Specify the neck wrap width.	

**CAUTION:**

To avoid possible accidents due to abrupt start of the machine, never place your feet or any other thing near the start switch.

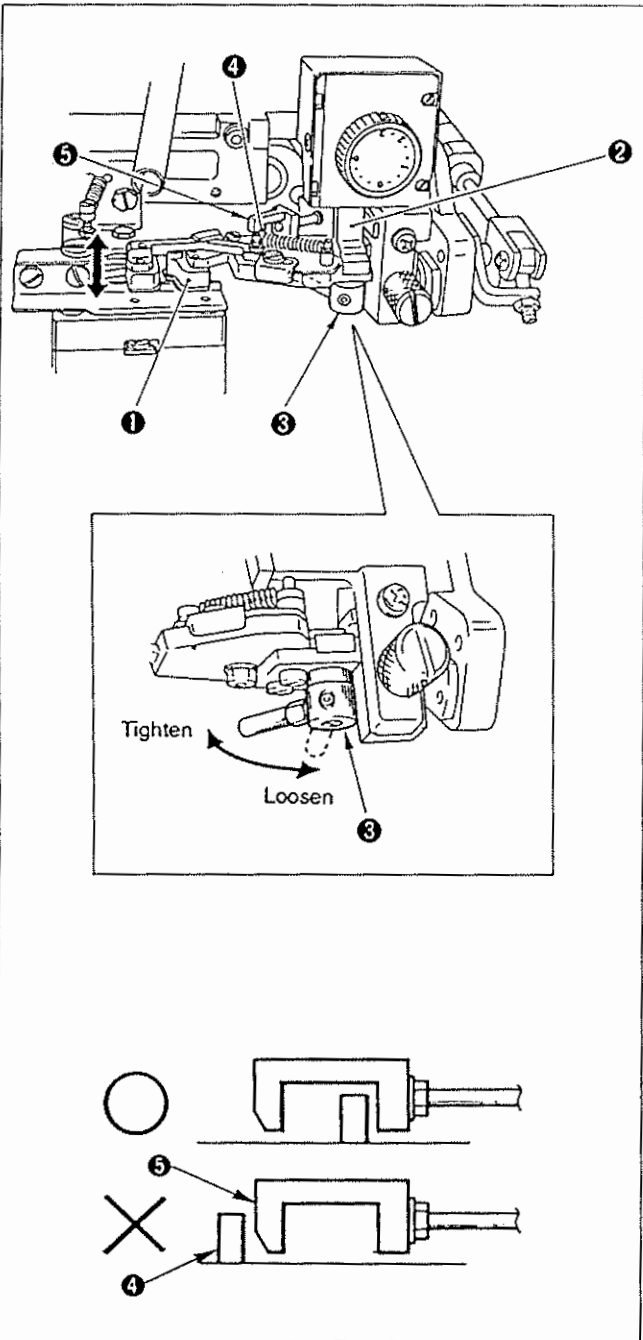

Attach/remove the button chuck following the procedure described below.

Button chuck comes in three different types, i.e., large, middle and small in accordance with the size of buttons to be sewn.

Button chuck, large:

Outside diameter of button $\phi 21$ to $\phi 32$ mm

Button chuck, middle:

Outside diameter of button $\phi 14$ to $\phi 25$ mm

Button chuck, small:

Outside diameter of button $\phi 8$ to $\phi 16$ mm

- 1) To remove button chuck ①, release lock lever ③, and draw out button chuck ① forward.
- 2) To attach button chuck ①, insert it between lock lever ③ and guide ② along with guide ②. Then fix lock lever ③.
- 3) When connecting the button chuck, pin ④ of button chuck ① should fit in button chuck actuating lever ⑤. If not, move chuck actuating lever ⑤ in the direction of the arrow until set pin ④ fits in lever ⑤.

(Caution) If actuating lever ⑤ is not fitted with set pin ④, a button cannot be set on the machine.

IV. OPERATION (Practical information)

1. Adjusting the height of neck wraps for sewing flat buttons

WARNING: Turn OFF the power before starting the work so as to prevent accidents caused by abrupt start of the sewing machine.

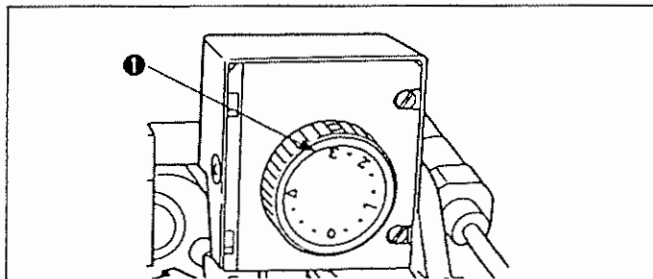

To change the height of neck wraps, adjust it as desired using neck wrap height adjusting knob ❶. Once the height of neck wraps is changed, the highest position of neck wraps will be automatically changed.

(1) Needle motion in accordance with the division on the scale (for neck wrapping)

The distance from the button to the highest position of neck wraps is constant. (Dimension a)

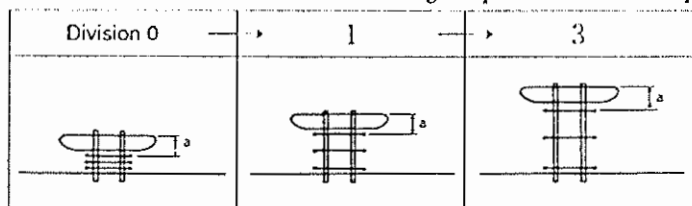

(2) Selecting the height of neck wraps (Number of neck wraps and the actual height of neck wraps)

Actual height of neck wraps varies with the type of thread, type of material, depth of tie stitches, type of button, stitch diagram and thread tension. Refer to the table shown below.

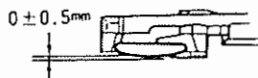

Shape of button

(Reference value)

Division on the scale	Number of neck wraps		Actual height
	Spun thread #30	Spun thread #50	
3	16 to 24	32 to 40	4.5 to 5.5 mm
2	12 to 20	24 to 32	3.5 to 4.5 mm
1	10 to 16	16 to 24	3 to 4 mm
0	6 to 12	10 to 16	2 to 3 mm

(3) To decrease the height of neck wraps

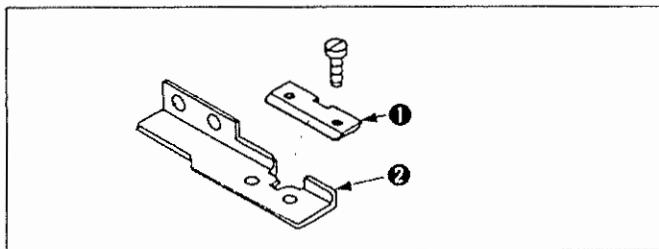

Attach spacer ❶ (part No. : 25005109), supplied with the machine as an accessory, to work clamp, lower ❷.

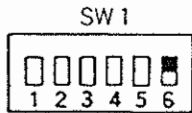
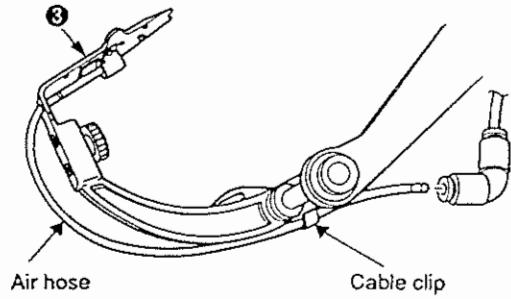
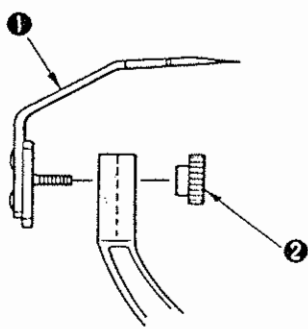

① in place, and replace the standard tongue with the tongue for the standard tongue with tongue asm. (for light-weight materials) ③.

2) Pass the air hose No. 11 through the cable clip, then connect it to the elbow (No. 11).

3) Set the switch 6 of the DIP switches 1 to the ON position.

(Caution) When using the tongue for light-weight materials with your machine, buttons will be sewn without stay stitches.

3. Changing over the operation mode for sewing buttons without the button neck

**WARNING:**

Turn OFF the power before starting the work so as to prevent accidents caused by abrupt start of the sewing machine.

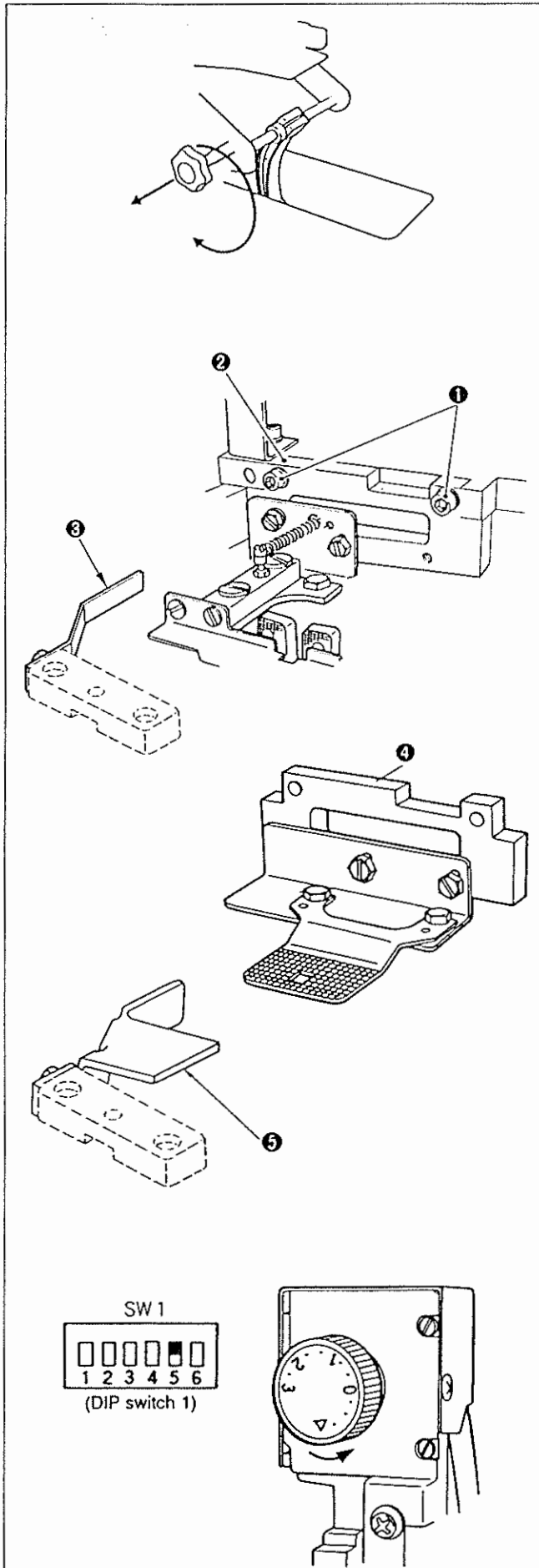

- 1) Drawing the knob, turn the tongue clockwise ☺ .
- 2) Remove the button chuck.
- 3) Remove two hexagon socket head cap screws ❶ .
- 4) Remove feed plate unit ❷ for tie stitches from the main unit.
- 5) Remove knife cover ❸ .
- 6) Install button sewing unit ❹ for sewing buttons without the button neck to the main unit and fix it with screws ❶ .
- 7) Set knife cover ❺ for sewing buttons without the button neck on the throat plate and attach them in position.
- 8) Set the switch 4 of DIP switches 1 to the ON position.
- 9) Set the neck wrap height adjusting knob at ▼ .

(Caution) Button sewing unit ❹ for sewing buttons without the button neck is optionally available. Place an order with us using the part number given below.
Button sewing unit ❹ for sewing buttons without the button neck: 25009051
Knife cover ❺ for sewing buttons without the button neck: 25009101

1. Adjusting the needle and the looper



WARNING:

Turn OFF the power before starting the work so as to prevent accidents caused by abrupt start of the sewing machine.

(1) Adjusting the height of the needle bar

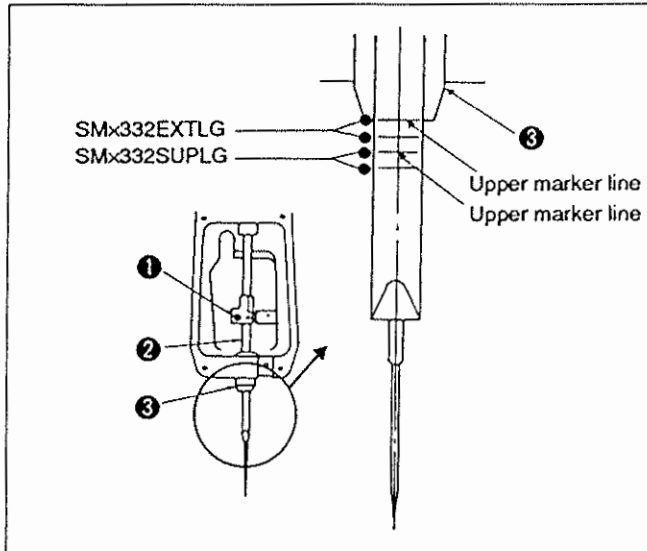

- 1) Turn the handwheel in the rotational direction to bring the needle bar to its lowest position. Then loosen screw ①.
- 2) Tighten screw ① while aligning the upper marker line (fourth marker line as counted from the bottom) engraved on needle bar ② with the bottom end of needle bar lower bushing ③.
- 3) The needle bar has the marker lines for the SMx332EXTLG needle and those for the SMx332SUPLG needle. So adjust the height of the needle bar according to the type of needle to be used.

(2) Adjusting the position of the needle and that of the looper

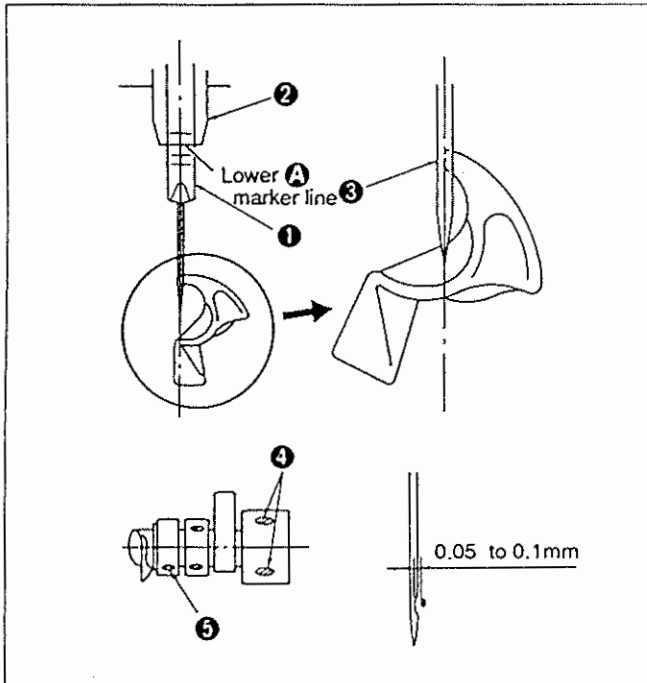

- 1) Loosen screw ④, and align lower marker line ① engraved on needle bar ① to the bottom end of needle bar lower bushing ② by turning the handwheel.
- 2) At this time, align blade point ③ of the looper with the center of the needle. Then tighten screws ④.
- 3) Loosen screw ⑤, and adjust the clearance between the looper and the needle to 0.05 to 0.1 mm. Then tighten screw ⑤.

2. Adjusting the needle and the needle guide

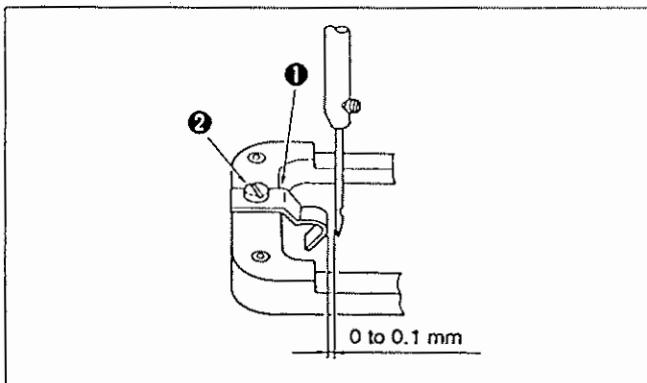

WARNING:

Turn OFF the power before starting the work so as to prevent accidents caused by abrupt start of the sewing machine.

Bring the needle bar to the lowest position of its stroke, and loosen screw ②. Move needle guide ① to the left or right to adjust the clearance between the needle and needle guide ① to 0 to 0.1 mm. Then tighten screw ②.

3. Adjusting the position of the yoke slide

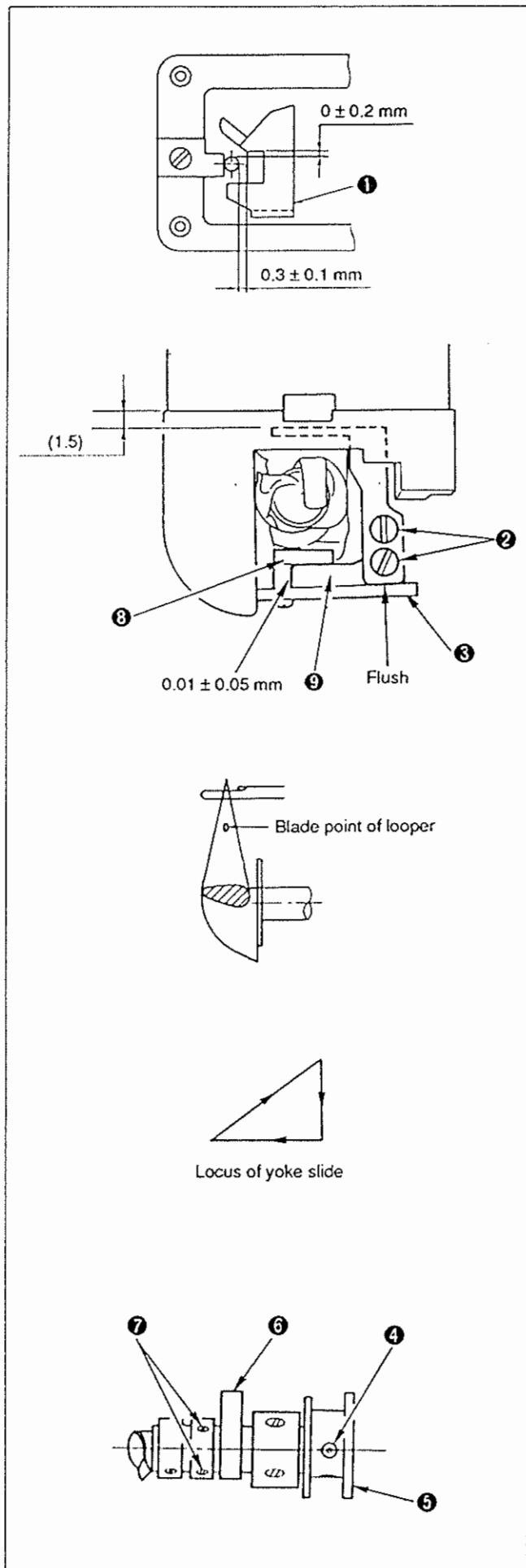

WARNING:

Turn OFF the power before starting the work so as to prevent accidents caused by abrupt start of the sewing machine.

- 1) When the needle bar is in the lowest position of its stroke, yoke slide ① is positioned so that a lateral clearance of 0.3 ± 0.1 mm and a longitudinal clearance of 0 ± 0.2 mm are provided between the needle and the yoke slide as illustrated in the figure on the left.
Yoke slide ① is vertically positioned so that the bottom end face of yoke slide installing plate ③ is flush with the bottom end face of yoke slide ①.
- 2) To adjust the lateral position of yoke slide ①, loosen screws ② and move yoke slide ① to the right and left.
- 3) To adjust the longitudinal position of yoke slide ①, loosen screw ④ and move yoke slide cam ⑤ back and forth.
- 4) With respect to the yoke slide moving timing, the yoke slide starts to move from the left to the right and also moves backward immediately after the blade point of the looper passes through the thread triangle.
- 5) To adjust the aforementioned timing, loosen screws ⑦ in triangular cam ⑥ of the yoke slide and turn the cam in the direction of rotation.
- 6) Loosen screw ④ in yoke slide cam ⑤, and adjust so that the yoke slide makes a triangular locus by turning the cam in the direction of rotation.
- 7) The clearance provided between yoke slide guide ⑧ and yoke slide installing plate ⑨ has been factory-adjusted to 0.01 to 0.05 mm.

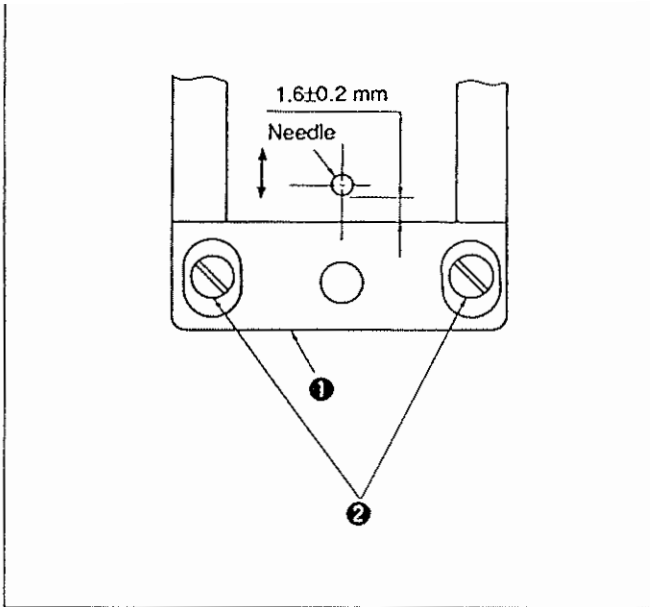

WARNING:

Turn OFF the power before starting the work so as to prevent accidents caused by abrupt start of the sewing machine.

- 1) Throat plate **1** has been assembled so that a clearance of 1.6 ± 0.2 mm is provided between throat plate **1** and the needle.
- 2) Loosen screws **2** in throat plate **1**, and adjust so that the aforementioned clearance is obtained between the throat plate and the needle by moving throat plate **1** back or forth.

5. Replacing the moving knife

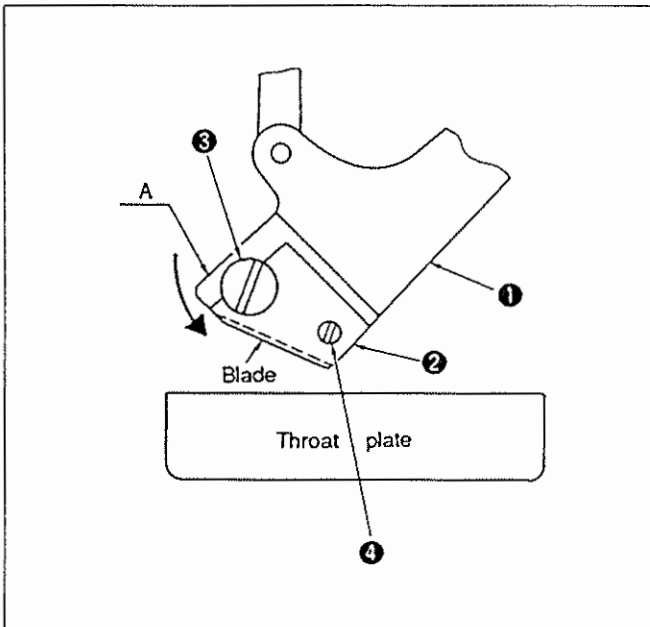

WARNING:

Turn OFF the power before starting the work so as to prevent accidents caused by abrupt start of the sewing machine.

- 1) Turn OFF the power switch.
- 2) Remove the button chuck (asm.).
- 3) Holding section A of moving knife fixing plate **1** from the left-hand side of the bed, draw out the moving knife unit in the direction of the arrow.
- 4) Loosen screw **3** in moving knife **2**, and replace moving knife **2** with a new one. After the replacement, fit the new moving knife under screw **3**. Then fit the knife over positioning screw **4**, and tighten screw **3**.
Be careful not to allow any object to hit against the blade of moving knife **2** when replacing the moving knife.

VI. LIST OF ERROR CODE

**CAUTION:**

To protect against possible accidents due to abrupt start of the machine, keep your hands, fingers and face away from moving parts of the main unit of the machine and place no tool near them.

If any of the following phenomenon occurs, the machine will give the indication of "AL?" on the indicating section LD1 of the operation circuit board. (The number corresponding to "?" is the error code.)

Error code	Description of error	Resetting procedure	Time of detection	Error correction
0	Improper setting of the number of stitches.	Find the number of stitches referring to the number of stitches indication label and properly set the number of stitches.	Specified number of stitches	Display only
2	There is no button sewing pattern.	Specify "without neck wraps" mode or select a proper sewing pattern.	When changing the sewing pattern	Display only
3	Data X for the button hole is outside the range of data.	Set X data to 2.0 to 5.0 mm. Set X-direction data to 0 when pattern 7 is selected.	When changing the X data	Display only
4	Data Y for the button hole is outside the range of data.	Set Y data to 2.0 to 5.0 mm. Set Y-direction data to 0 when pattern 8 is selected.	When changing the Y data	Display only
7	Neck wrap width is outside the range of data.	Set the SW8 and SW9 on the operation circuit board so that the total of the neck wrap width specified by those switches does not exceed 8 mm.	When changing the X data or when changing the neck wrap width.	Display only
10	Vertical position of the chuck is outside the range of data when sewing buttons with neck wraps .	Set the chuck up/down dial to 2.5 or more.	When selecting the "with neck wraps" mode, or when changing the set value on the chuck up/down dial.	Display only
12	During pause	Press the reset switch.	When the pause switch is set to the ON state	All the functions of the machine are inoperative.
13	Improper upper-stop of needle	Bring the needle bar to the upper stop position and press the set switch.	During sewing	Emergency stop
		Bring the needle bar to the highest stop position. (Under the manual sewing mode or manual neck wapping mode)	Under the manual operation or when turning the power on	Display only
17	Synchronizer signal is defective.	Correct the synchronizer.	When starting sewing	Stop of function
18	Defective start of rotation of the sewing machine motor.	Correct the sewing machine motor and the synchronizer	When starting sewing	Stop of function
19	Defective stop of rotation of the sewing machine motor.	Correct the sewing machine motor and the synchronizer	During sewing	Stop of function
20	Needle-down signal is defective.	Correct the synchronizer.	During sewing	Stop of function
21	Needle-up stop position is defective.	Correct the sewing machine motor.	During sewing	Stop of function
22	Defective detection of X origin	Correct the X-origin sensor and X-stepping motor.	When turning ON the power to the machine	All the functions of the machine are inoperative.
23	Defective detection of Y origin	Correct the Y-origin sensor and Y-stepping motor.	When turning ON the power to the machine	All the functions of the machine are inoperative.
24	X-origin sensor is improperly adjusted.	Adjust the position of the X-origin sensor properly.	When turning ON the power to the machine	All the functions of the machine are inoperative.

code				
25	Y-origin sensor is improperly adjusted.	Adjust the position of the Y-origin sensor properly.	When turning ON the power to the machine	All the functions of the machine are inoperative.
26	Encoder is attached to an improper position.	Correct the position of the encoder.	When changing the set value on the chuck up/down dial	Display only
28	Tongue set sensor is attached to an improper position.	Adjust the position of the tongue set sensor.	When starting sewing	All the functions of the machine are inoperative.
29	Improper chuck thread trimming position	Check the air supply, correct the chuck sensor, correct the solenoid valve, or correct the related mechanism.	During sewing or thread trimming	Stop of function
30	The moving knife has not returned to the origin.	Check the air supply, correct the cutter origin sensor, correct the solenoid valve or correct the related mechanism.	When starting sewing or during sewing or thread trimming	Stop of function
31	Chuck is not leveled.	Check the air supply, correct the chuck horizontal sensor, correct the solenoid valve, or correct the related mechanism.	When turning ON the power to the machine or at the completion of sewing with neck wraps	Stop of function
32	Chuck is not perpendicular.	Check the air supply, correct the chuck horizontal sensor, correct the solenoid valve, or correct the related mechanism.	When starting sewing with neck wraps	Stop of function
33	Tongue fails to be released.	Check the air supply, correct the tongue set sensor, correct the solenoid valve, or correct the related mechanism.	When turning ON the power to the machine or at the completion of sewing	Stop of function
34	The moving knife fails to actuate.	Check the air supply, correct the cutter origin sensor, correct the solenoid valve, or correct the related mechanism.	During sewing or thread trimming	Stop of function
39	Improper air pressure	Check the air supply, correct the thread feeding sensor, correct the solenoid valve, or correct the related mechanism.	When turning ON the power to the machine	Stop of function
40	Loader sensor failure	Adjust the position and replace the sensor with a new one. (Check the connector.)	When turning the power on	Stop of function
41	The loader is in the inserting position when turning the power on or resetting it.	Return the loader link by hand to the button setting position and press the reset switch.	When turning the power on	Stop of function

VII. AIR PIPING DIAGRAM



WARNING:

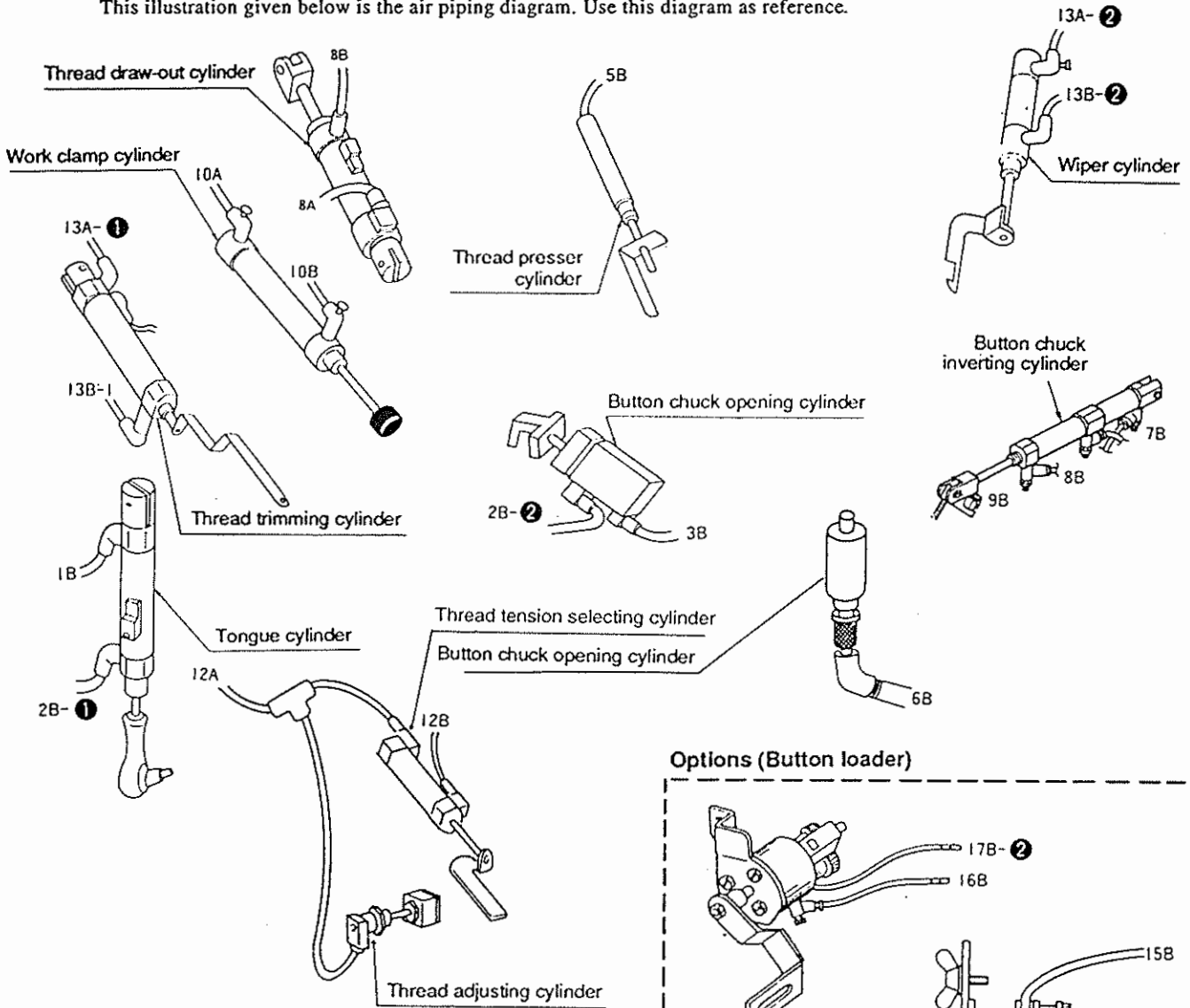

Turn OFF the power before starting the work so as to prevent accidents caused by abrupt start of the sewing machine.

This illustration given below is the air piping diagram. Use this diagram as reference.

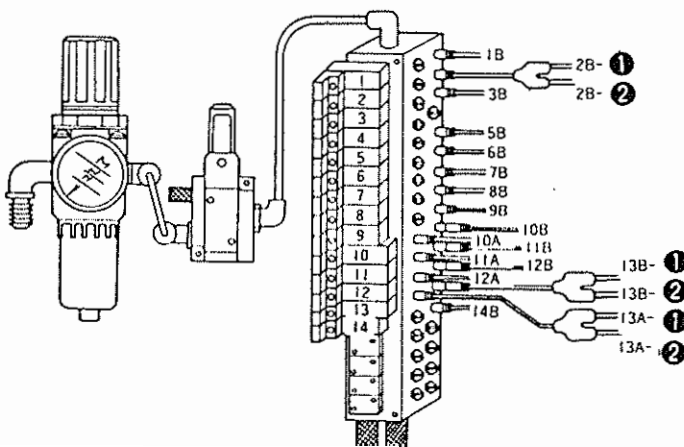
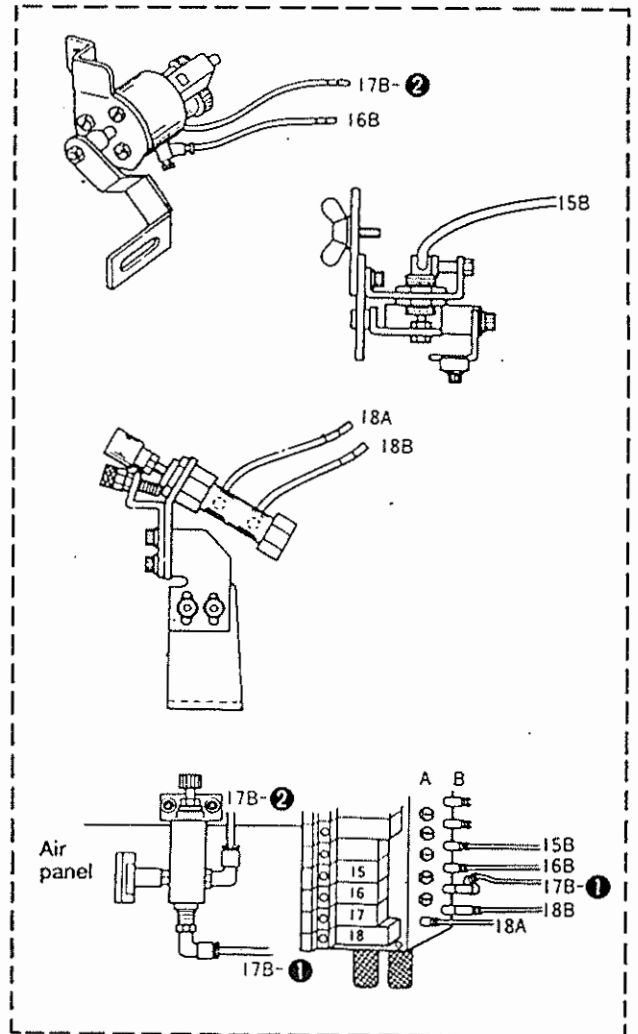

Options (Button loader)

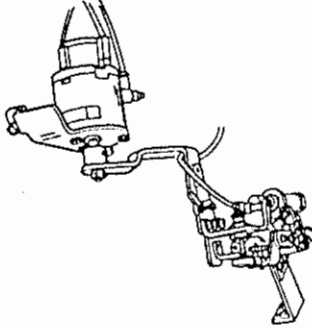
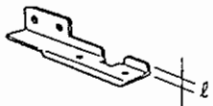
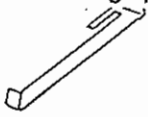

Name of part	Type	Part No.	Remarks
1. Button loader, general asm. 	-----	25343450	-----
2. Work clamp, lower 	-----	25005208	$l = 5.5\text{mm}$
3. Thread retaining spring 	-----	17826504	For light-weight materials
4. Work clamp lower plate (for sewing buttons without the button neck) 	Work clamp lower plate for large buttons	17828906	$l = \square 7.5\text{mm}$
	Work clamp lower plate for small buttons	17829102	$l = \square 4.8\text{mm}$

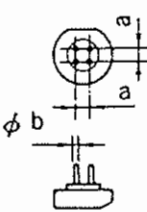
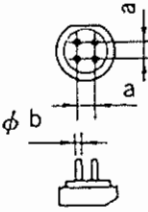
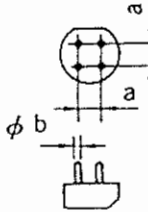
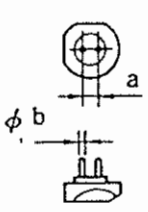
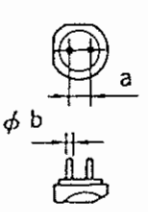
Button carrier (for 4-holed buttons)						Button carrier (for 2-holed buttons)								
1		2		3		4		5						
														
Engraved mark	Part No.	Dimension	Engraved mark	Part No.	Dimension	Engraved mark	Part No.	Dimension	Engraved mark	Part No.	Dimension	Engraved mark	Part No.	Dimension
A	17856600	a 2.0 b 1.0	D	17856907	a 2.8 b 1.2	K	17857608	a 4.0 b 1.4	M	17858002	a 2.0 b 1.0	U	17858705	a 4.0 b 1.4
B	17856709	a 2.4 b 1.2	E	Standard 17857004	a 2.8 b 1.4	K I	17857707	a 4.0 b 1.8	N	17858101	a 2.4 b 1.2	V	Standard 17858804	a 4.2 b 1.4
C	17856808	a 2.6 b 1.2	F	17857103	a 3.0 b 1.2	I.	17857806	a 5.0 b 1.8	P	17858200	a 2.6 b 1.2	W	17858903	a 4.4 b 1.4
			F I	17857202	a 3.0 b 1.4				Q	17858309	a 2.8 b 1.2	X	17859000	a 4.6 b 1.4
			G	17857301	a 3.2 b 1.4				R	17858408	a 3.0 b 1.2	Y	17859109	a 4.8 b 1.4
			H	Standard 17857400	a 3.4 b 1.4				S	17858507	a 3.2 b 1.4	Z	17859208	a 5.0 b 1.4
			J	17857509	a 3.6 b 1.4				T	Standard 17858606	a 3.4 b 1.4			

IX. INSTALLATION OF THE BUTTON LOADER

1. Parts and names of parts

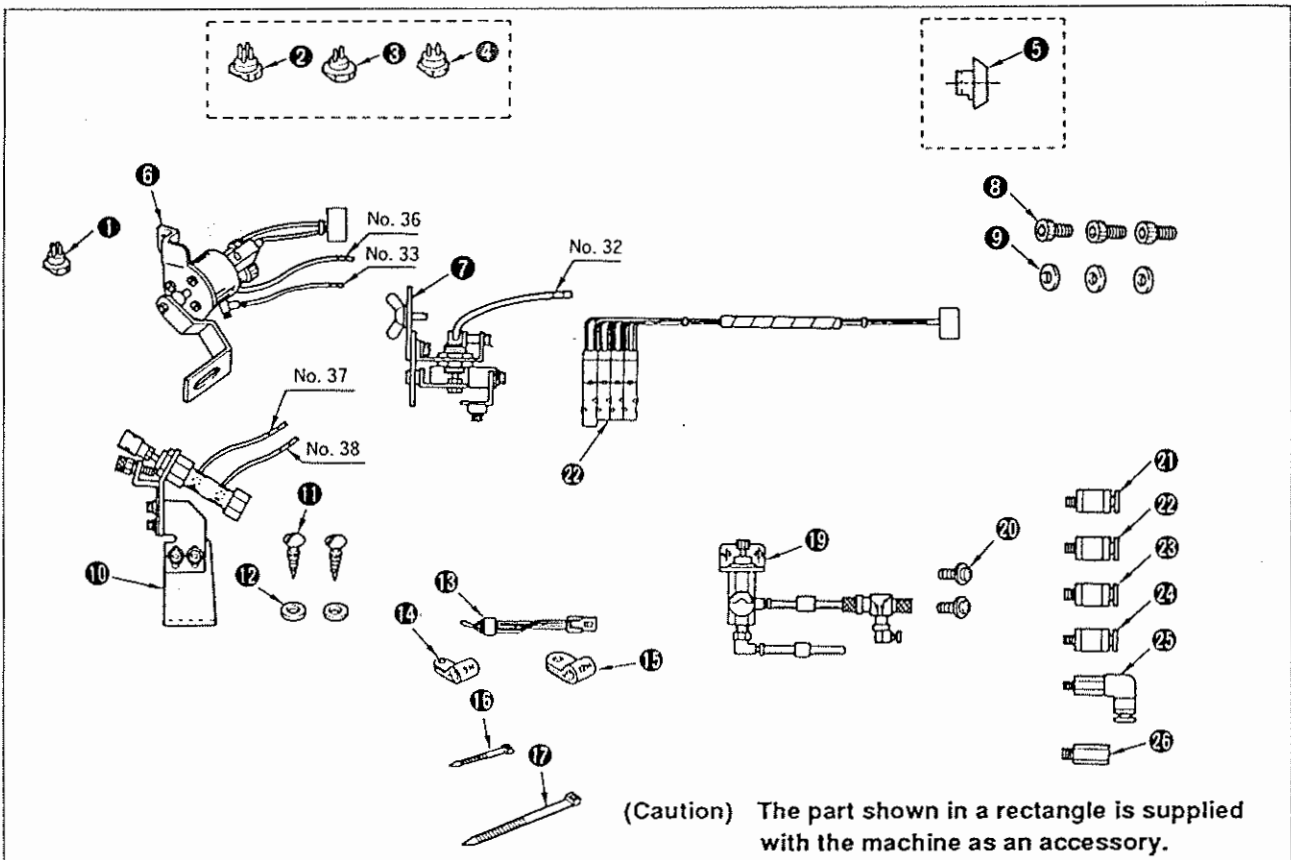

No.	Part No.	Name of part	Q'ty	No.	Part No.	Name of part	Q'ty
①	17857400	Button carrier for 4-holed buttons. H	1	⑮	HX00150000K	Cable clip	1
②	17857004	Button carrier for 4-holed buttons. E	1	⑯	EA9500B0100	Wire band	10
③	17858606	Button carrier for 2-holed buttons. T	1	⑰	HX00065000B	Wire band	3
④	17974551	Set pin for metallic buttons	1	⑱	25014457	Solenoid valve (asm.)	1
⑤	17974700	Set pin gauge	1	⑲	17852559	Pressure reducing valve (asm.)	1
⑥	25014051	Button loader unit (A)	1	⑳	SL4040891SC	Screw	2
⑦	25014259	Button loader unit (B)	1	㉑	17852955	Half union C (asm.)	1
⑧	SM6051002TR	Screw	3	㉒	17853052	Half union D (asm.)	1
⑨	WP0531000SC	Washer	3	㉓	17853151	Half union E (asm.)	1
⑩	25014556	Button loader stopper (asm.)	1	㉔	17853250	Half union F (asm.)	1
⑪	SK3513200SC	Screw	2	㉕	17853359	Long elbow (asm.)	1
⑫	WP0561616SC	Plain washer	2	㉖	PJ010505001	Extension joint	1
⑬	17973751	Button loader switch (asm.)	1				
⑭	HX00150000G	Cable clip	1				



WARNING: Turn OFF the power before starting the work so as to prevent accidents caused by abrupt start of the sewing machine.

(1) Installing the button loader unit to the sewing machine

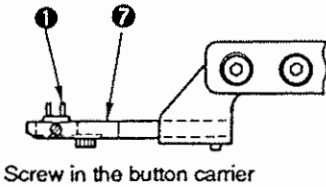
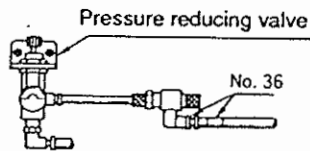
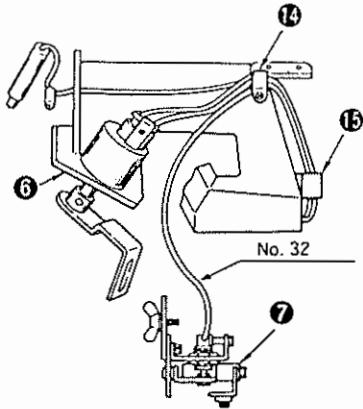
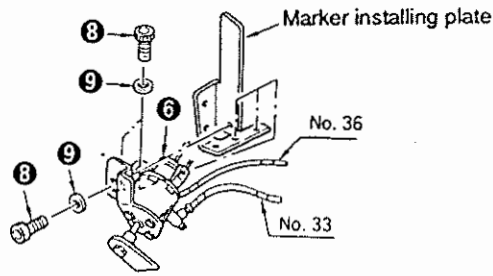

Screw in the button carrier

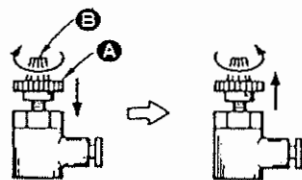
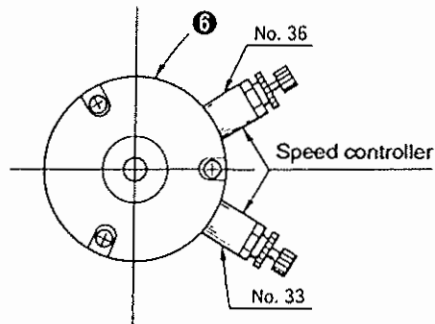

- 1) Attach button loader unit (A) 6 to the marker installing plate of the sewing machine using screws 8 and washers 9.
- 2) Replace the cable clips mounted on the position shown in the figure with cable clips 14 and 15.
- 3) Pass two air hoses coming from button loader unit (A) 6, two sensor cords and an air hose coming from button loader unit (B) 7 through cable clips 14 and 15.
- 4) Connect the air hose No. 36 coming from button loader unit (A) 6 to the pressure reducing valve No. 36. Connect the air hose No. 33 to half union D (asm.) 22 (on page 31) of the solenoid valve.
Connect the air hose No. 32 coming from button loader unit (B) 7 to half union C (asm.) 21 (on page 31) of the solenoid valve.
- 5) Loosen the screw for fixing the button carrier of button loader unit (B) 7, then attach button carrier for 4-holed buttons H 1 to the button loader.
- 6) Adjust the speed controllers mounted on button loader unit (A) 6.
Loosen locknut A of the speed controller, tighten knob E by turning it.
Now, turn the knob in the reverse direction by the following number of revolutions.
No. 33 → 2 to 2.5 revolutions
No. 36 → 2 to 2.5 revolutions
After the adjustment, tighten locknut A.

(Caution) Button feeding speed is regulated by the speed controller No. 36. The button loader returning speed is regulated by the speed controller No. 33.

(2) Assembling the solenoid valves and pressure reducing valves

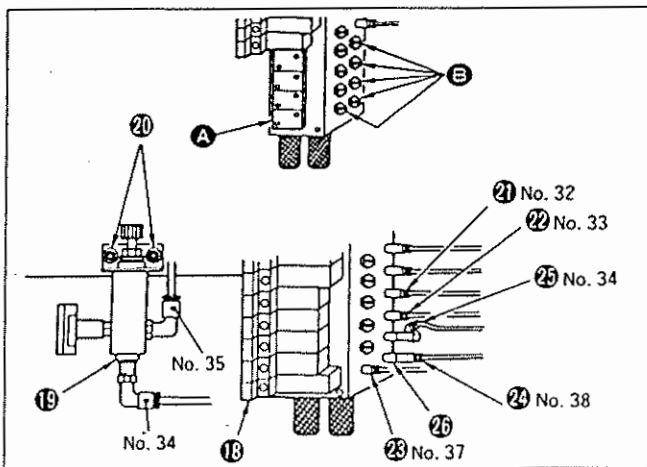

- 1) Remove four blanking plates **A** and five plugs **B**.
- 2) Solenoid valve (asm.) **18** : Assemble solenoid valves No. 15 through No. 18 in the numerical order. (Take care of the packings.)
- 3) Attach half union assemblies **C** through **F** **21** through **24**, long elbow (asm.) **25** and extension joint **26** to the locations illustrated in the figure. (Assemble the half union assemblies using a hexagon wrench key with 2 mm opposite side length.)
- 4) Attach pressure reducing valve **19** onto the air panel with screws **20**.
- 5) Pass the air hose No. 34 of pressure reducing valve **19** on the rear side of the air panel and connect it to long elbow (asm.) **25**.

(3) Air piping for the loader stopper (asm.)

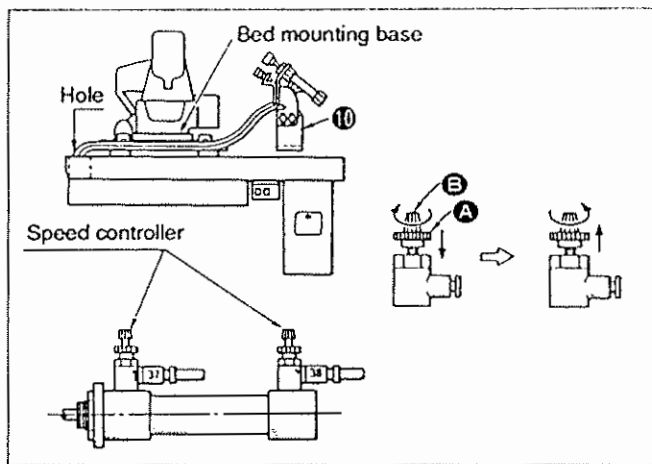

- 1) Pass the air hose of loader stopper (asm.) **10** along the bed mounting base located under the bed and put it into the hole in the table.
- 2) Connect the air hoses No. 37 and No. 38 coming from loader stopper (asm.) **10** to half union **E** (asm.) **23** (on page 41) and half union **F** (asm.) **24** (on page 41) of the solenoid valve.
- 3) Adjust the speed controllers.
Loosen locknut **A** of the speed controller, tighten knob **E** by turning it.
Now, turn the knob in the reverse direction by the following number of revolutions.
No. 37 → 1 to 1.5 revolutions
No. 38 → 1 to 1.5 revolutions
After the adjustment, tighten locknut **A**.

(4) Installing the button loader operation switch

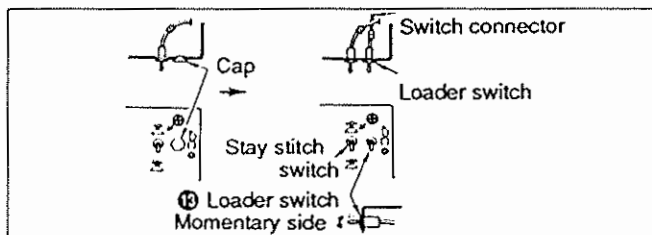

- 1) Remove the cap that is located next to the stay stitch switch.
- 2) Holding button loader switch **13** with its momentary side up, attach it to the operation box with a nut.
(Caution) The momentary switch indicates a switch that will return to its home position even when pushing it.
- 3) Connect the connector of the button loader switch to the switch connector.

(5) Wiring the solenoid valve lead and sensor cable

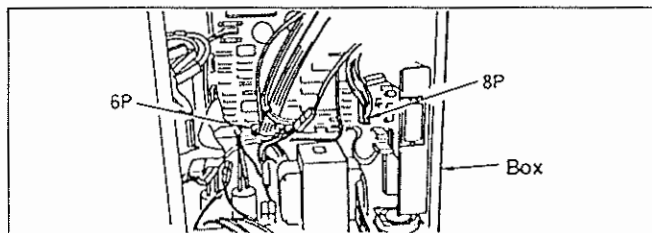

Connect the solenoid valve lead (8P) and sensor cable (6P) to the connectors mounted inside the operation box.

(6) Changing over the DIP switches inside the operation box

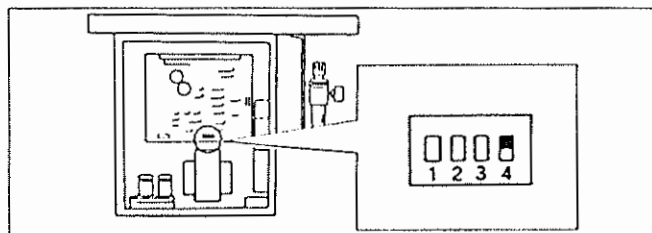

Set the switch No. 4 of the DIP switches 1 (SW1) mounted inside the operation box to its ON position.

(1) Checking the operating air pressure and adjusting it

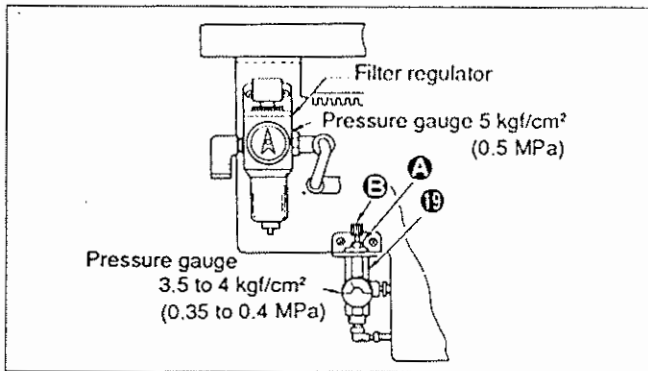

- 1) Confirm that the pressure gauge of the filter regulator indicates an air pressure of 5 kgf/cm² (0.5 MPa).
- 2) Turn ON the power to the machine.
At this time, loosen nut **A**, and adjust so that pressure gauge asm. **B** indicates an air pressure of 3.5 to 4 kgf/cm² (0.35 to 0.4 MPa) by turning knob **B**. After the adjustment, tighten nut **A**.

(2) Adjusting the button feeding of the loader link A

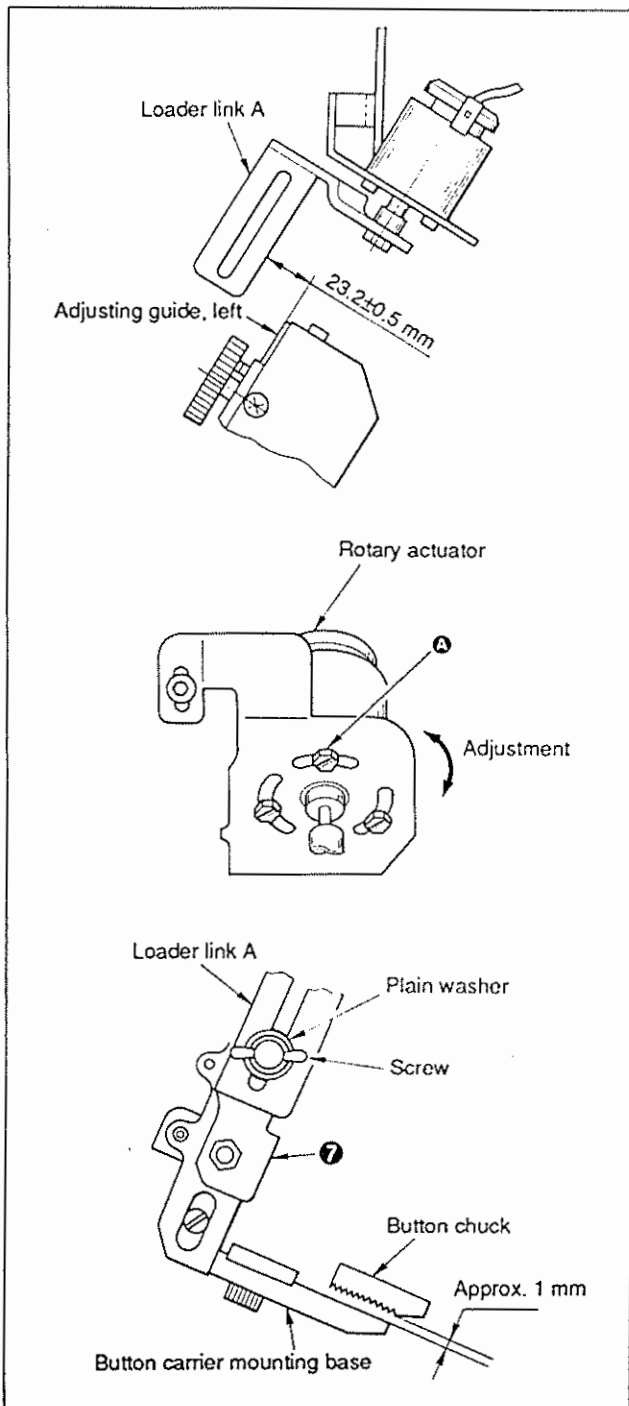

- 1) Set the mode switch on the operation panel to the manual stitching position.



- 2) Turn ON the power to the machine.
- 3) Operate the button loader switch to make the button loader perform independent operation until the loader link A is brought to the button chuck unit.
- 4) Loosen three screws **A** in the rotary actuator, and turn the rotary actuator to adjust so that a clearance of 23.2±0.5 mm is provided between the loader link A and the adjusting guide, left.
After the adjustment, tighten the three screws.
- 5) Operate the button loader switch to make the button loader perform independent operation until the button chuck is fixed. Now, attach loader unit (B) **7** to the loader link A at the position as shown in the figure.
Adjust so that a clearance of approximately 1 mm is provided between the button chuck and the button carrier mounting base. Now, tighten the screw.

(3) Adjusting the position of the rotary actuator sensor

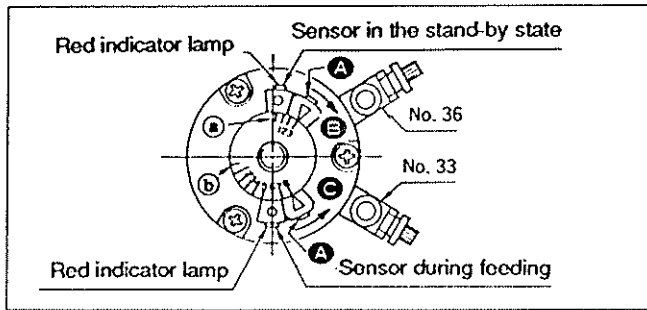

- 1) Loosen screws (A) and properly position the sensors. Then tighten screws (A).
- When the sensor is in the stand-by state, it should be positioned at a location that is reached by moving it by three divisions of scale in direction (E) from position (a) at which the red indicator lamp starts to light up.
- When the sensor is in the feeding state, it should be positioned at a location that is reached by moving it by eight divisions of scale in direction (C) from position (b) at which the red indicator lamp starts to light up.

(4) Adjusting the angle of the button carrier

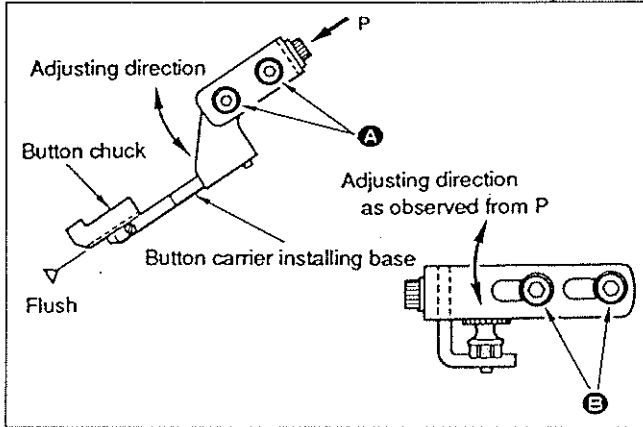

- 2) Make the button loader perform single-step of operation by using the button loader switch to fix the button chuck.
- 3) Loosen screws (A) and (E). Adjust so that the undersurface of the button chuck is flush with the top face of the button carrier installing base. After the adjustment, tighten the screws.

(5) Adjusting the position of the button carrier in terms of longitudinal, lateral and vertical directions

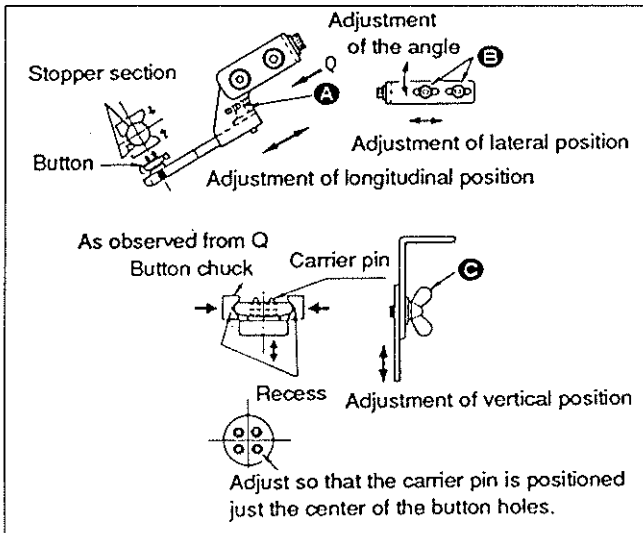

- 1) Loosen screws (E), and adjust the lateral position of the button carrier.
At this time, also adjust the angle of the button carrier. After the adjustment, temporarily tighten screws (A).
- 2) Loosen screw (C), and adjust the vertical position of the button carrier so that the projecting part of the button to be used is exactly aligned with the recess of the button chuck. After the adjustment, tighten the screw.
- 3) Loosen screw (A) and re-adjust the longitudinal position of the button carrier so that the button comes in contact with the stopper section of the button chuck and that the carrier pin of the button carrier is positioned just the center of the button holes.
After the adjustment, tighten screw (A).
- 4) Set the operation selecting switch to the automatic operation mode .
- 5) Set the button loader switch to the position. Now, release the switch.
A button will be fed to the button chuck.
- 6) Now, change over the button loader switch from the position to , then to position.
At this time, lightly press this side of the button, i.e., position (D) in the figure, by fingers in the direction of the arrow to check whether the button will move. When the button will not move at all, the longitudinal position of the button loader has been properly adjusted.
At the same time, check whether the button is twisted when being fed.
- If the button is fed with twisted, attach the button carrier while slightly turning it.

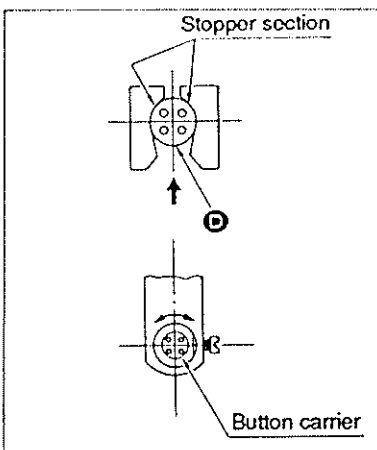

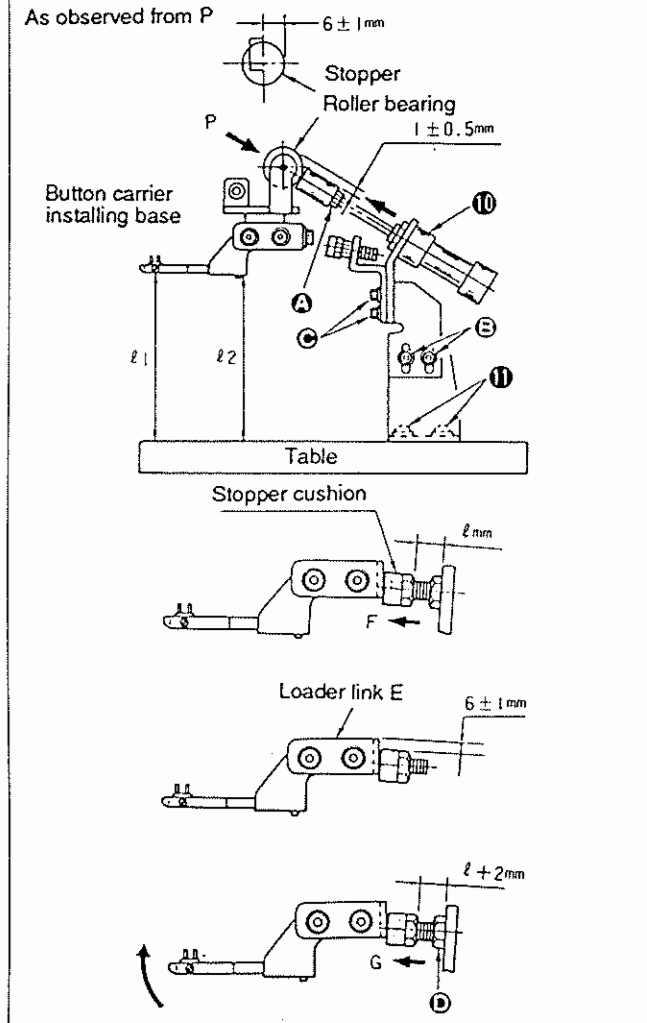

- 1) Turn ON the power to the machine.
- 2) Fix loader stopper (asm.) ⑩ onto the table surface using screws ⑪ so that the stopper of the loader stopper (asm.) is spaced $1 \pm 0.5 \text{ mm}$ and $6 \pm 1 \text{ mm}$ from the roller bearing as illustrated in the figure.
- 3) Loosen screws ③, and adjust the button loader so that the aforementioned dimensions are obtained. After the adjustment, tighten the screws.
Loosen nut ④, and adjust so that the button carrier installing base is in parallel to the top face of the table ($l_1 = l_2$) by moving the stopper back or forth.
- 4) Loosen screws ⑥ and adjust so that the stopper is $6 \pm 1 \text{ mm}$ away from the roller bearing when the stopper cushion is moved in the direction of arrow F, as illustrated in the figure, until loader link E is reached.
- 5) Now, measure dimension l .
- 6) Then, move the stopper cushion in the direction of arrow G, as illustrated in the figure, by 2 mm.
Now, tighten nut ④.

(7) Binding the air hoses

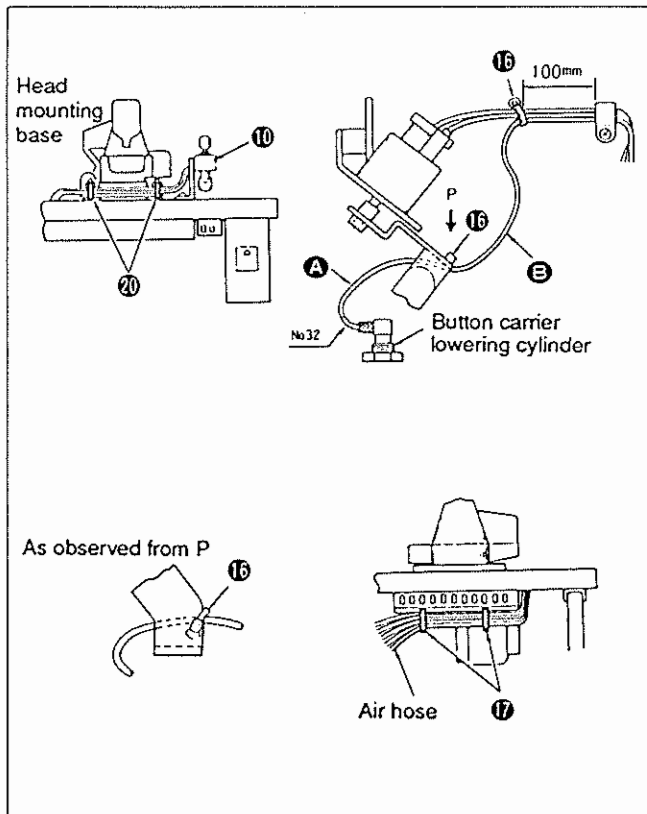

- 1) Bind the air hoses of loader stopper (asm.) ⑩ with wire band ⑫ at the position of two holes in the bed mounting base.
 - 2) Bind the air hose of the button carrier lowering cylinder with wire band ⑬ as illustrated in the figure.
Route the air hoses taking care that it is not excessively tensed at section ①. Also, take care that section ② of the air hose does not come in contact with the X-Y drive of the machine.
Furthermore, section ① of the air hose should not interfere with the other components.
- (Caution)** When binding the air hose, take care not to batter the air hose. If the air hose is battered, smooth flow of the air in it will be impaired.
- 3) Use wire band ⑭ to bind the air hoses located on the rear side of the sewing machine.

4. Independent operation

(1) Manual operation function

Purpose: Used, when the button to be sewn is changed, to adjust the button chuck to the button.

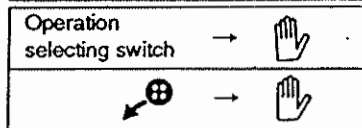

- Turn ON the switch for every step of operation.
- " → (Flat buttons) Button carrier inclines from the horizontal position.
 - " → Button chuck inclines from the horizontal position.
 - " → Button loader moves to the button chuck unit and the button chuck opens.
 - " → Button chuck is fixed.
 - " → Button carrier comes down.
 - " → Button loader returns to its home position.
- (Shank buttons)
- " → Button loader moves to the button chuck unit and the button chuck opens.
 - " → Button chuck is fixed.
 - " → Button loader returns to its home position.

(2) Button loader stand-by function

Purpose: The machine is provided with the function to keep the button loader in the stand-by state at the button presetting unit to prevent the case where only the button loader moves to the button chuck unit when the button is not preset in position during sewing.

As long as the PK62 foot pedal is held depressed in its ON state, the button loader will never actuate.
Release the foot pedal, and the button loader will actuate.

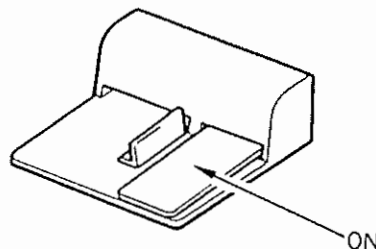

(3) Single-step operation of the button loader

Purpose: Used to actuate the button loader when you have not yet put a button in the presetting unit.

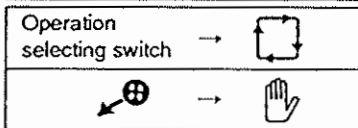

- Turn ON the switch
- " → (Flat buttons) Button carrier inclines from the horizontal position.
 - ↓
 - " → Button chuck inclines from the horizontal position.
 - ↓
 - " → Button loader moves to the button chuck unit and the button chuck opens.
 - ↓
 - " → Button chuck is fixed.
 - ↓
 - " → Button carrier comes down.
 - ↓
 - " → Button loader returns to its home position.
- (Shank buttons)
- " → Button loader moves to the button chuck unit and the button chuck opens.
 - ↓
 - " → Button chuck is fixed.
 - ↓
 - " → Button loader returns to its home position.

(4) Continuous operation of the button loader

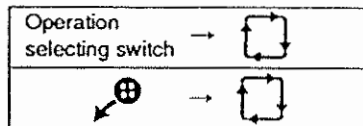

In this state, the button loader will automatically actuate after the completion of sewing.

5. Precautions to be taken

(1) When sewing thin buttons

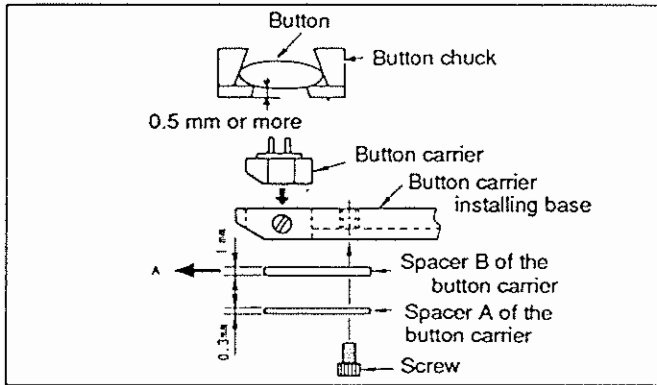

If there is a distance of 0.5 mm or more between the button and the bottom of the button carrier as illustrated in the figure, remove the screw and fully move spacer B in the direction of arrow A so that they protrude most.

Attach spacer A to the underside of spacer B. Then, tighten the screw.

Then, attach the button carrier onto spacer B.

(Caution) Assemble the aforementioned components as stated above only in the case of sewing thin buttons.

(2) Caution to be taken when using sewing patterns for sewing buttons without neck wraps

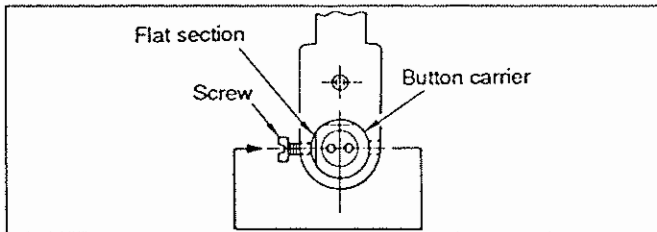

To use the pattern No. 8 with the button carrier for 2-holed buttons, attach the button carrier as illustrated, change the position of the screw over to the reverse side.

6. Explanation of the panel

(1) Explanation of the operation panel A



CAUTION:

To avoid possible accidents due to abrupt start of the machine, never place your feet or any other thing near the start switch.

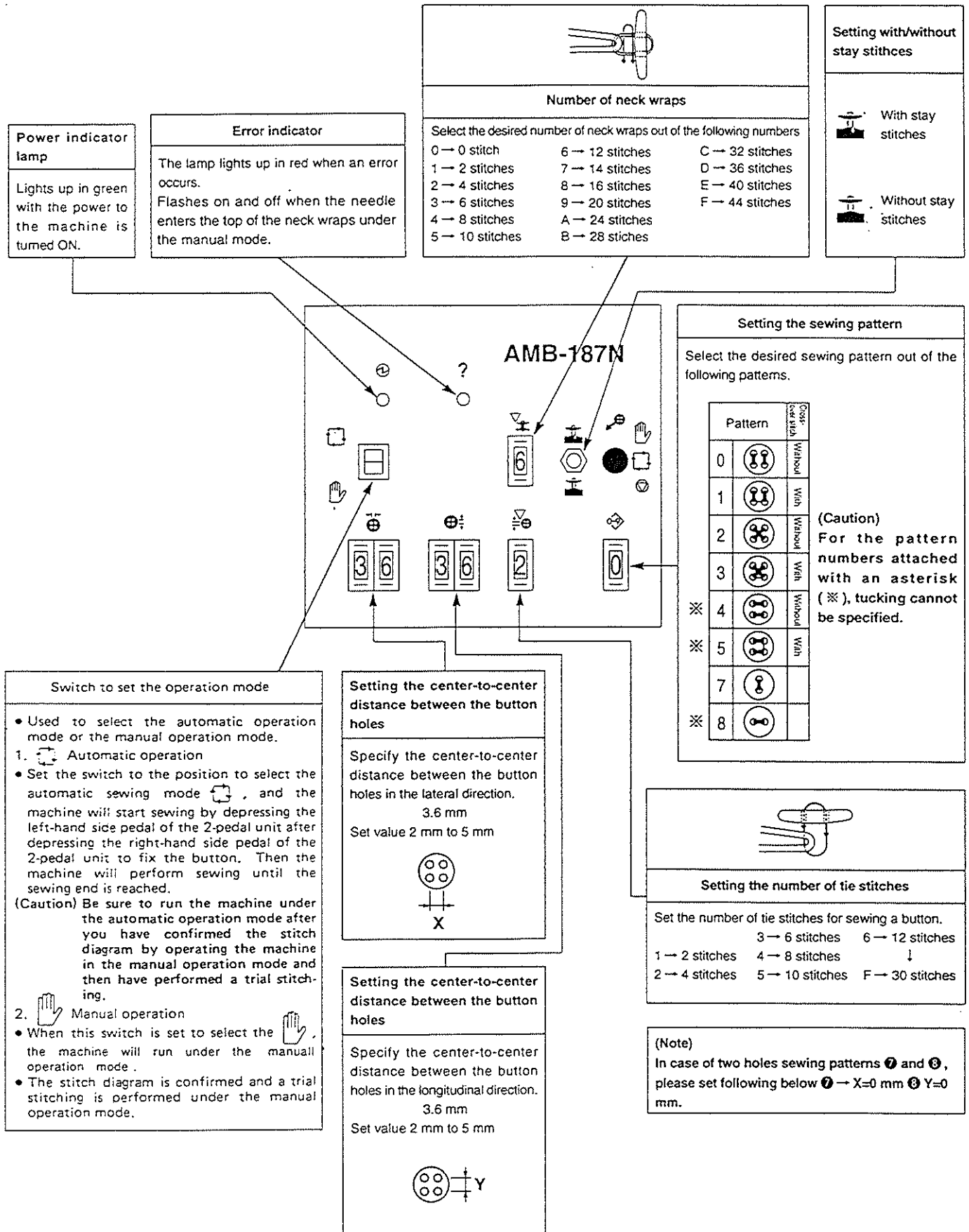

Power indicator lamp
Lights up in green with the power to the machine is turned ON.

Error indicator
The lamp lights up in red when an error occurs.
Flashes on and off when the needle enters the top of the neck wraps under the manual mode.

Number of neck wraps
Select the desired number of neck wraps out of the following numbers

0 → 0 stitch	6 → 12 stitches	C → 32 stitches
1 → 2 stitches	7 → 14 stitches	D → 36 stitches
2 → 4 stitches	8 → 16 stitches	E → 40 stitches
3 → 6 stitches	9 → 20 stitches	F → 44 stitches
4 → 8 stitches	A → 24 stitches	
5 → 10 stitches	B → 28 stitches	

Setting with/without stay stitches

With stay stitches

Without stay stitches

Switch to set the operation mode

- Used to select the automatic operation mode or the manual operation mode.

- Automatic operation**
 - Set the switch to the position to select the automatic sewing mode , and the machine will start sewing by depressing the left-hand side pedal of the 2-pedal unit after depressing the right-hand side pedal of the 2-pedal unit to fix the button. Then the machine will perform sewing until the sewing end is reached.

(Caution) Be sure to run the machine under the automatic operation mode after you have confirmed the stitch diagram by operating the machine in the manual operation mode and then have performed a trial stitching.
- Manual operation**
 - When this switch is set to select the , the machine will run under the manual operation mode.
 - The stitch diagram is confirmed and a trial stitching is performed under the manual operation mode.

Setting the center-to-center distance between the button holes

Specify the center-to-center distance between the button holes in the lateral direction.

3.6 mm
Set value 2 mm to 5 mm

Setting the center-to-center distance between the button holes

Specify the center-to-center distance between the button holes in the longitudinal direction.

3.6 mm
Set value 2 mm to 5 mm

Setting the sewing pattern

Select the desired sewing pattern out of the following patterns.

Pattern	Coop. Sewing	With/Without
0		Without
1		With
2		Without
3		With
* 4		Without
* 5		With
7		
* 8		

(Caution) For the pattern numbers attached with an asterisk (*), tucking cannot be specified.

Setting the number of tie stitches

Set the number of tie stitches for sewing a button.

1 → 2 stitches	3 → 6 stitches	6 → 12 stitches
2 → 4 stitches	4 → 8 stitches	↓
	5 → 10 stitches	F → 30 stitches

(Note)
In case of two holes sewing patterns ⑦ and ⑧, please set following below ⑦ → X=0 mm ⑧ Y=0 mm.

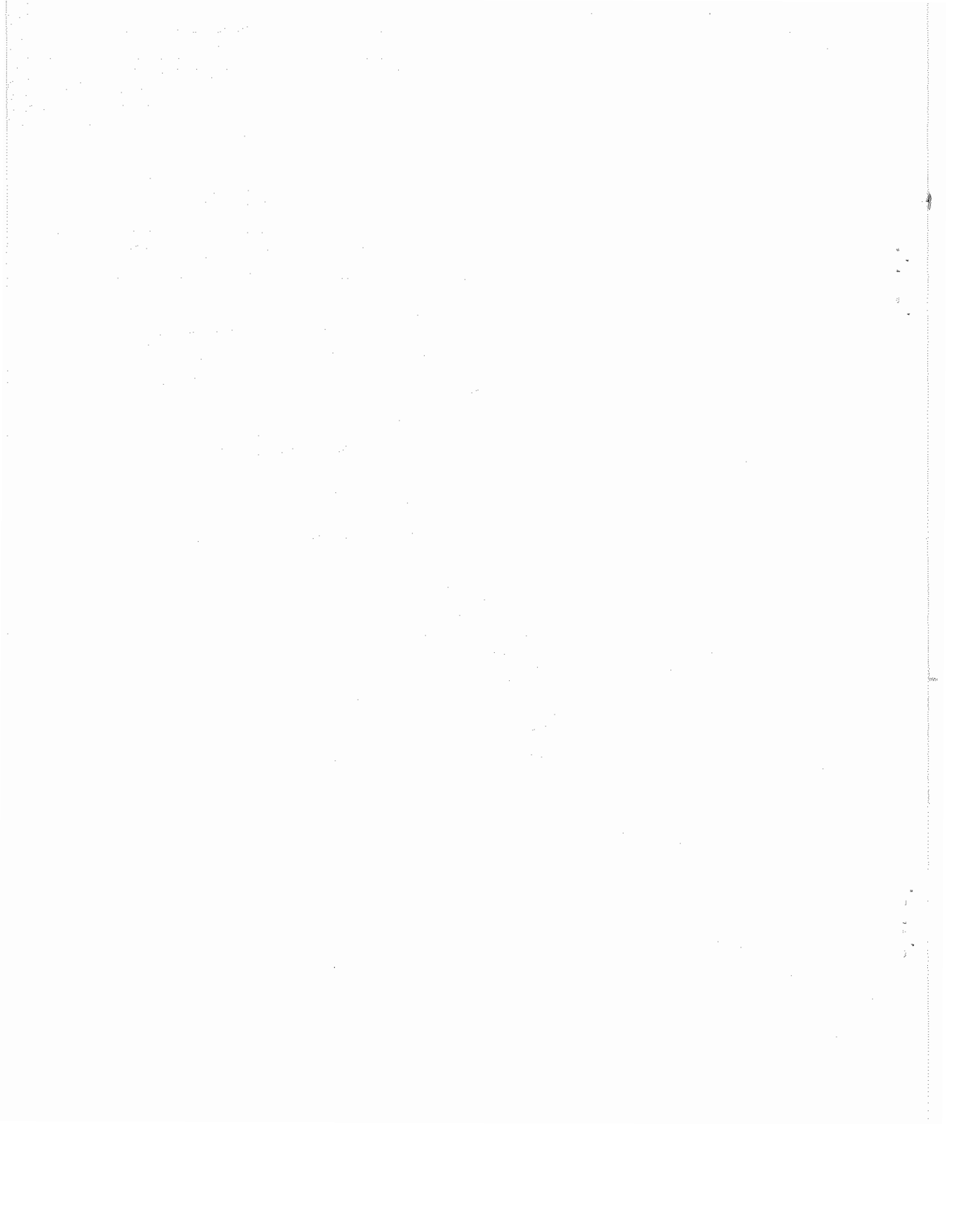

(2) Explanation of the operation panel B



CAUTION:
To avoid possible accidents due to abrupt start of the machine, never place your feet or any other thing near the start switch.

SW1 ON/OFF (stop area of delivery)

These are the buttons:

1 stitch	ON	OFF
2 stitches	ON	OFF

Number of stay stitches No. 1

Used to specify the number of stay stitches.

1 stitch	ON	OFF
2 stitches	ON	OFF

Number of first stitches for neck wrapping No. 1

Used to specify the number of stitches to be made on the material in the first process of neck wrapping.

1 stitch	ON	OFF
2 stitches	ON	OFF

Number of stay stitches No. 2

Used to specify the number of stay stitches.

1 stitch	ON	OFF
2 stitches	ON	OFF

Number of stay stitches No. 3

Used to specify the number of stay stitches.

1 stitch	ON	OFF
2 stitches	ON	OFF

Used to specify the location of the stitches No. 4

Used to specify the location of the stitches in the neck wrapping process.

Center of neck wrap	ON	OFF
Right hand	ON	OFF
Left hand	ON	OFF

SW5 ON/OFF (stop area of delivery)

These are the buttons:

1 stitch	ON	OFF
2 stitches	ON	OFF

SW6 ON/OFF (stop area of delivery)

These are the buttons:

1 stitch	ON	OFF
2 stitches	ON	OFF

SW7 ON/OFF (stop area of delivery)

These are the buttons:

1 stitch	ON	OFF
2 stitches	ON	OFF

Setting the start position of neck wrapping SW4

To move the start position of neck wrapping toward the cloth, set the switch to a smaller value. On the contrary, set the switch to a larger value to move the start position of neck wrapping toward the button. The moving amount of the start position is specified in increments of 0.2 mm.

The center of the button is the reference for setting of the start position of neck wrapping.

Scale	Distance A
0	-0.6 mm
1	-0.4 mm
2	-0.2 mm
3	0 mm
14	2.2 mm
15	2.4 mm

Adjusting the origin in the X direction SW2

The position of the origin with respect to the X direction is freely adjustable by using this switch.

Adjusting the origin in the Y direction SW3

The position of the origin with respect to the Y direction is freely adjustable by using this switch.

Indicator of error code/number of stitches LO1

- When LO1 indicates the error code or the specified values of the number of the stitches and the number of neck wraps.
- Since the LED only indicates the number of single step, it shows the number in turn. For "AL13" it indicates as "14" and "15" while flashing on and off. For "16" it indicates as "16" while flashing on and off.
- It reports indicating the number of the stitches and the number of neck wraps three times after the relevant data changing.

Setting the highest position of the neck wraps SW6

To move the highest position of the neck wraps to the cloth, set the switch to a larger value. On the contrary, set the switch to a smaller value to move the highest position of the neck wraps to the button. The moving amount is specified in increments of 0.2 mm. Note that this setting is permitted only when the knob to adjust the neck wrap height is set to 2.5 on the scale. The center of the button is the reference for setting. Increasing the neck wrap height will automatically increase value A.

Scale	Distance A
0	1.5 mm
1	1.3 mm
2	1.1 mm
3	0.9 mm
14	-1.3 mm
15	-1.5 mm

1. With neck wraps

2. Without neck wraps

Setting the needle entry point for the first stitch of neck wraps SW7

The needle entry point can be specified from the button position toward the button within the range of -1 to +2 mm in increments of 0.2 mm.

This data is necessary to align the needle entry on the material in the 1st process.

SW8 SW9 SW10

SW8: 0-9, SW9: 0-9, SW10: 0-9

Reset switch SW10

This switch is pressed to reset the machine to the normal operation mode after correcting an error.

Setting the location of the stitches SW9

Used to specify the location of the stitches.

The location of the stitches (the last stitch) can be specified within the range of -1 to +2 mm in increments of 0.2 mm toward the material.

Adjust so that a clearance of 0.1 to 0.3 mm is provided between the material and the needle.

Setting the stitch width for neck wrapping SW6

The stitch width is specified from the center to either end of the button within the range of 0 to 3 mm in increments of 0.2 mm (max. stitch width 6 mm).

The stitch width is specified from the center to either end of the button within the range of 0 to 3 mm in increments of 0.2 mm (max. stitch width 6 mm).

Setting the location of the stay stitch SW5

The location of the stay stitch can be specified from the button hole toward the cloth within the range of 0 to 3 mm in increments of 0.2 mm.

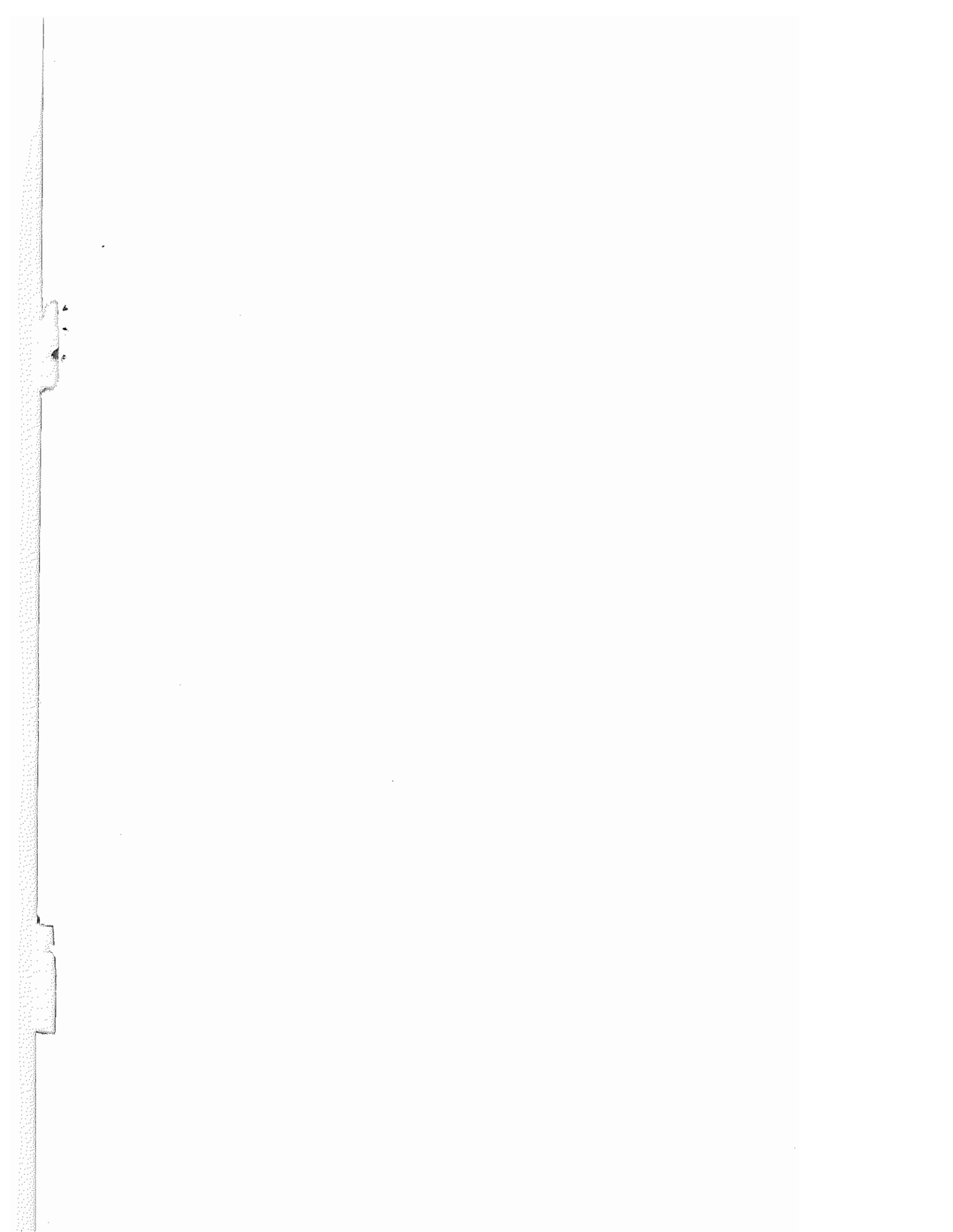

JUKI®

To order or for further information, please contact:
Um Ihre Bestellung aufzugeben oder weitere Informationen anzufordern, wenden Sie sich bitte an:
Pour commander ou pour plus d'information s'adresser à:
Para hacer pedidos o para ulterior información, sírvase ponerse en contacto con:
Per ordinare o per ulteriore informazione, si prega di mettersi in contatto con:

Please do not hesitate to contact our distributors or agents in your area for further information when necessary.
Bitte wenden Sie sich an unsere Händler oder Vertreter in Ihrer Nahe, wenn Sie weitere Informationen benötigen.
Pour plus d'information, n'hésitez pas à consulter nos distributeurs ou agents dans votre région.
Sírvase ponerse en contacto con nuestros distribuidores o agentes en su área siempre que necesite alguna información más detallada.
Per ulteriore informazione, si prega di non esitare a mettersi in contatto con nostri distributori o agenti vostra area quando necessario.

JUKI CORPORATION
INTERNATIONAL SALES DIVISION
8-2-1, KOKURYO-CHO,
CHOFU-SHI, TOKYO 182, JAPAN
PHONE : 03 (3430) 4001-5
FAX : 03 (3430) 4909-4914-4984
TELEX : J22967

- * The description covered in this instruction manual is subject to change for improvement of the commodity without notice.
- * Änderungen der in dieser Betriebsanleitung enthaltenen Beschreibungen, die der Verbesserung des Produktes dienen, bleiben vorbehalten.
- * Les spécifications données dans le présent Manuel d'utilisation sont sujettes à modification sans préavis.
- * La descripción que se da en este manual de instrucciones está sujeta a cambio sin previo aviso por razones de mejora de la mercancía.
- * Le descrizioni contenute in questo manuale d'istruzioni sono soggette a modifiche senza alcun preavviso.