

JUKI[®]

**Computer-controlled, High-speed,
Lockstitch Buttonholing Machine**

LBH-1790 Series

ENGINEER'S MANUAL

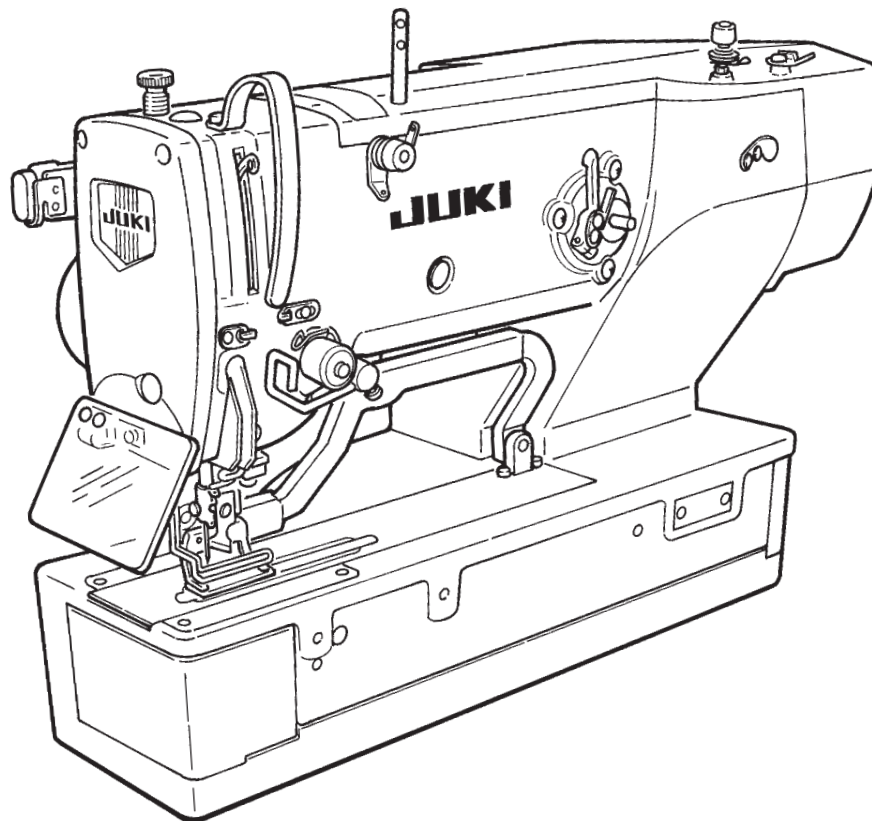

40006360
No.E352-02

PREFACE

This Engineer's Manual is written for the technical personnel who are responsible for the service and maintenance of the machine.

The Instruction Manual for these machines intended for the maintenance personnel and operators at an apparel factory contains operating instructions in detail. And this manual describes "Standard Adjustment", "Adjustment Procedures", "Results of Improper Adjustment", and other important information which are not covered by the Instruction Manual.

It is advisable to use the relevant Instruction Manual and Parts List together with this Engineer's Manual when carrying out the maintenance of these machines.

In addition, for the motor for the sewing machine with thread trimmer, refer to the separate Instruction Manual or Engineer's Manual for the motor. And for the control panel, refer to the Instruction Manual for the control panel.

This manual gives the "Standard Adjustment" on the former page under which the most basic adjustment value is described, and on the latter page "Results of Improper Adjustment" under which stitching errors and troubles arising from mechanical failures are described together with the "Adjustment Procedures".

CONTENTS

1. SPECIFICATIONS	1
2. STANDARD SEWING SHAPE LIST	2
3. STANDARD ADJUSTMENT	3
(1) Height of the needle bar	3
(2) Needle-to-hook timing	3
(3) Adjusting the feed timing belt tension	5
(4) Knife drop position	5
(5) Adjusting the stroke and initial position of the cloth cutting knife	7
(6) Adjusting the rotary play of the cloth cutting knife	9
(7) Replacing the knife	9
(8) Adjusting the needle thread trimmer	11
1) Adjusting the thread grasping force of the needle thread trimmer	11
2) Adjusting the height of the needle thread trimmer	11
3) Needle thread trimming adjustment mode	13
4) Adjusting the needle thread trimmer origin sensor	15
5) Lateral adjustment of the needle thread trimmer (start of sewing)	15
6) Longitudinal and lateral adjustment of the needle thread trimmer (at the time of trimming)	17
7) Opening amount of the needle thread trimmer	17
8) Adjusting the needle thread draw-in amount	19
(9) Adjusting the bobbin thread trimmer	19
1) Bobbin thread trimmer adjustment mode	19
2) Adjusting the bobbin thread trimming origin sensor	21
3) Adjusting the position of the trimmer	21
4) Replacing the bobbin thread trimmer	23
5) Open timing and open amount	23
(10) Adjusting the presser lifter	25
1) Adjusting the backlash of the presser lifter gear	25
2) Adjusting the presser bar position bracket	25
3) Adjusting the presser lifter origin sensor	27
① Adjusting the sensor	27
② Refer to the adjusting procedure of the presser lifter motor origin compensation	27
(11) Adjusting the thread tension	29
1) Adjusting the stroke of the thread tension solenoid	29
2) Adjusting the thread take-up spring tension (purl stitching)	29
(12) Adjusting the bobbin winder	31
(13) Adjusting the thread breakage detecting plate	31
(14) Adjusting the bobbin presser	33
(15) Adjusting the pedal	35

4. ADJUSTING EACH SENSOR	37
(1) Adjusting the needle rocking origin	37
1) Needle rocking motor origin compensation	38
(2) Adjusting the feed origin	39
1) Feed motor origin compensation	40
5. DISASSEMBLING/ASSEMBLING PROCEDURE	41
(1) Disassembling/assembling the main shaft	41
(2) Replacing the timing belt (main shaft).....	43
(3) Replacing the timing belt (hook driving shaft)	45
(4) Adjusting the timing belt of main shaft (idler)	47
(5) Disassembling/assembling the face plate section	49
(6) Disassembling/assembling the needle rocking motor.....	51
(7) Replacing the cloth cutting knife solenoid	53
(8) Replacing the cloth cutting knife solenoid cushion.....	55
(9) Replacing the knife return stopper	57
6. LUBRICATION	59
(1) Lubricating oil to oiling tank.....	59
(2) Adjusting the lubrication for the sewing hook.....	59
(3) Applying grease	59
1) Main shaft components	59
2) Presser and feed components	60
3) Needle bar rocking components	61
4) Needle thread trimmer components	62
5) Cloth cutting knife components	63
7. OPERATION PANEL.....	65
(1) Structure of the operation panel	65
(2) Initial value data for each shape table	67
8. VARIOUS DATA LIST	68
(1) Sewing data list.....	68
(2) Memory switch data list	74
9. EXPLANATION OF SHAPE	78
10. DETAILED EXPLANATION OF CONTINUOUS STITCHING	86
11. ERROR CODE LIST	87

12. ELECTRICAL COMPONENTS	90
(1) Change of data ROM	90
(2) Adaptation to the high voltage	90
(3) DIP switch.....	90
(4) Adaptation to the PK pedal	91
(5) Fuse list	92
13. GAUGE COMPONENTS AND OPTIONAL COMPONENTS	93
14. OTHERS	95
(1) Points of replacement for feed 70 mm and 120 mm	95
15. TROUBLES AND CORRECTIVE MEASURES	97
(1) With regard to sewing	97
(2) With regard to mechanical components	106
(3) With regard to electrical components	107
16. TIME CHART	123
17. CIRCUIT DIAGRAM	125
(1) Block diagram A (3-phase 200 to 240V).....	125
(2) Block diagram B (Single phase 230V (for CE))	126
(3) Block diagram C (Single phase 220 to 240V)	127
(4) Power circuit diagram (3-phase 200 to 240V)	128
(5) Power circuit diagram (Single phase 220 to 240V).....	129
(6) Power circuit diagram (Single phase 100V)	130
(7) Servo motor circuit diagram	131
(8) Stepping motor/solenoid circuit diagram.....	132
(9) Head sensor circuit diagram	133
(10) Pedal switch circuit diagram	134
(11) Connection circuit diagram between control box and head	135
18. DRAWING OF THE TABLE	136

1. SPECIFICATIONS

No.	Item	Model	Specifications	
			LBH-1790S	LBH-1790S
1	Stitch width*1		5 mm (Resolution : 0.05 mm)	
2	Cloth cutting knife size (Knife length)		6.4 to 31.8 mm (1/4" to 1-1/4")	
3	Stitch length (max.)*2		41 mm	
4	Sewing speed		Standard 3,600 rpm Max. 4,200 rpm (Dry hook : Max. 3,300 rpm)	
5	Speed control system		Panel input and variable resistor	
6	Needle		DPX5 #11J to 14J	
7	Needle bar stroke		34.6 mm	
8	Thread take-up lever		Link thread take-up lever	
9	Hook		DP type full-rotary automatic lubricating hook, (Dry hook : DP type RP hook : optional)	
10	Lift of work clamp check		14 mm (optional setting possible) Max. 17 mm (When reverse revolution to lift needle function is set.)	
11	Presser lifting drive system		Stepping motor system (1-pedal, 2-pedal)	
12	Bobbin winder		Built-in machine head type (Bobbin winding possible only when sewing machine rotates)	
13	Feed drive method		Stepping motor drive (Timing belt)	
14	Needle rock drive system		Stepping motor drive	
15	Cloth cutting knife drive system		Double acting solenoid drive	
16	Adjustment of needle thread		Active tension method Digital setting for each section by means of operation panel (Parallel section tension, bar-tacking section tension, etc.)	
17	Sewing shape		Square shape, radial shape, round shape, etc. 30 shapes (selection by operation panel)	
18	Number of patterns stored in memory		99 patterns	
19	Data memory medium		Smart media (When IP-200 is used)	
20	Data communication function		Possible with IP-200	
21	External pattern creation		Possible with PM-1	
22	Change-over of 1/2 stitching		Each pattern can be set.	
23	Input voltage classification (Power consumption)		Domestic : 1ø 100V/ 3ø 200V (1000VA) Export : 1ø 220 to 240V (CE : Single phase 230V without power switch) / 3ø 200 to 240V (1000VA)	
24	Motor		Compact AC servo motor 450W Direct-drive method	
25	Lubrication method		Face plate section : dry Hook section : minute quantity lubrication (dry hook : no lubrication)	
26	Lubricating oil		JUKI New Defrix oil No.1 (Equivalent to ISO VG7)	
27	Grease		JUKI exclusive grease, TEMPLEX	
28	Dimensions		Width of machine bed : 200 mm, Height : 364 mm, Length : 630 mm	
29	Weight of machine head		55 Kg	

Model classification : S : standard, K : for knit

	Presser type 1	Presser type 2	Presser type 3	Presser type 5
Stitch width	4 mm	5 mm	5 mm	3 to 10 mm (Optional setting)
Sewing length (Max.)	25 mm	35 mm	41 mm	10 to 120 mm (Optional setting)

For *1 and 2, stitch width can be changed to max. 10 mm by replacing optional parts.

Besides, for the sewing length, it can be changed to max. 120 mm (70 mm).

2. STANDARD SEWING SHAPE LIST

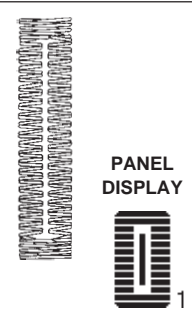
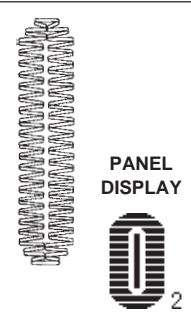
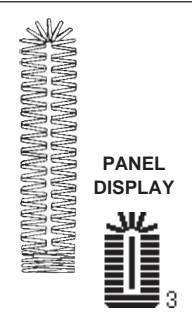
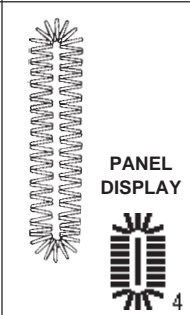
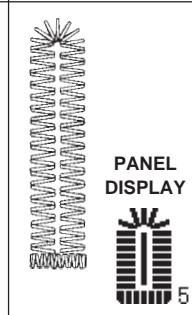
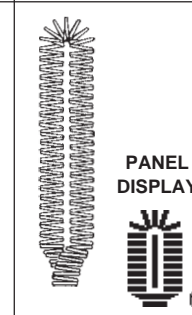
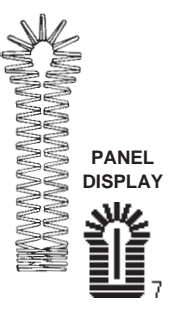
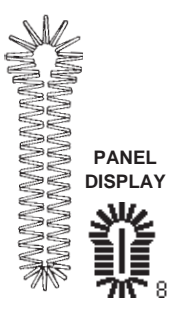
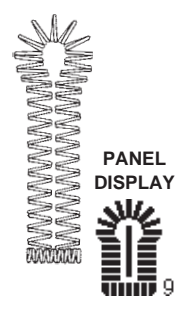
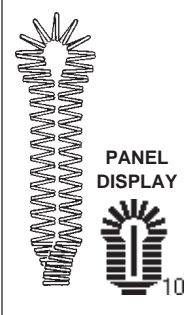
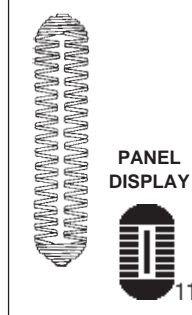
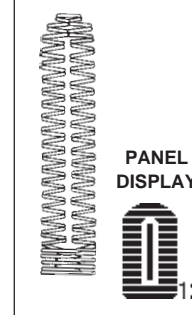
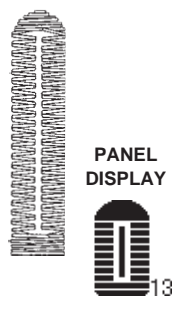
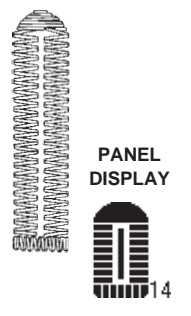
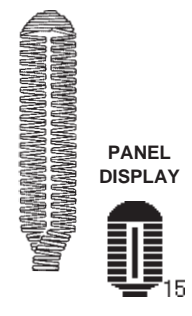
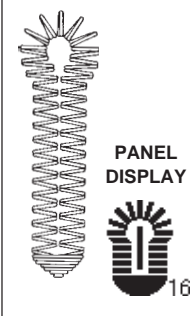
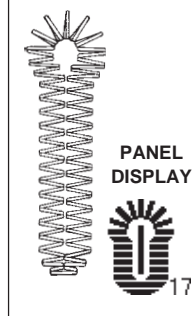
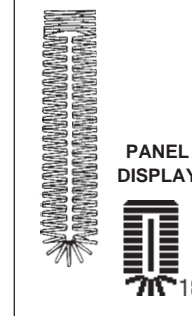
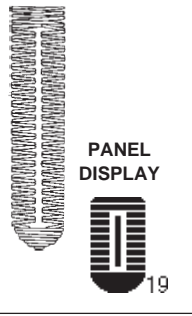
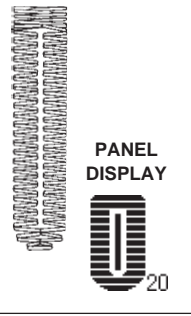
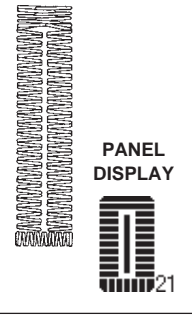
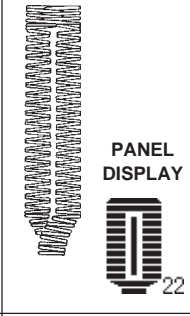
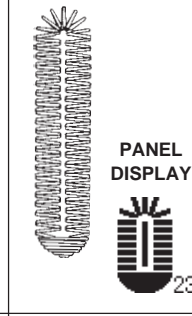
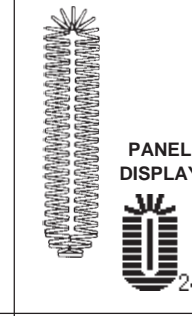
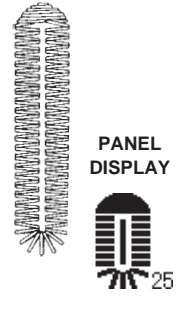
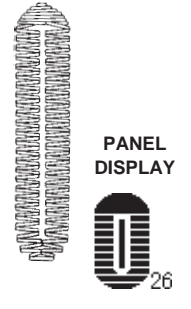
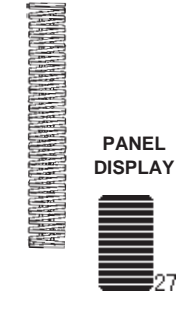
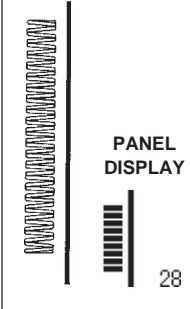
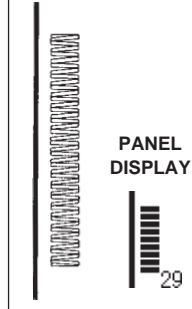
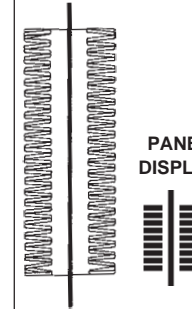
(1) Square type	(2) Round type	(3) Radial square type	(4) Radial type	(5) Radial straight bar-tacking type	(6) Radial taper bar-tacking type
					
(7) Eyelet square type	(8) Eyelet radial type	(9) Eyelet straight bar-tacking type	(10) Eyelet taper bar-tacking type	(11) Semilunar type	(12) Round square type
					
(13) Semilunar square type	(14) Semilunar straight bar-tacking type	(15) Semilunar taper bar-tacking type	(16) Eyelet semilunar type	(17) Eyelet round type	(18) Square radial type
					
(19) Square semilunar type	(20) Square round type	(21) Square straight bar-tacking type	(22) Square taper bar-tacking type	(23) Radial semilunar type	(24) Radial round type
					
(25) Semilunar radial type	(26) Semilunar round type	(27) Bar-tacking	(28) Bar-tacking, right cut	(29) Bar-tacking, left cut	(30) Bar-tacking, center cut
					

3. STANDARD ADJUSTMENT

(1) Height of the needle bar

Standard Adjustment

Adjust the height of the needle bar so that the distance from the top surface of the throat plate to the lower end face of the needle bar is 12.0 mm (S : standard) or 11.3 mm (K : knit) when the needle bar is in the lowest dead point.

(2) Needle-to-hook timing

Standard Adjustment

- 1) Blade point of the hook is aligned with the center of the needle when the needle bar goes up by 2.5 mm (S : standard) or by 3.0 mm (K : knit) from its lowest dead point.
At this time, the distance from the top end of the needle eyelet to the blade point of the hook is 1.6 to 1.8 mm (needle is in the central section of the hole in the throat plate).
- 2) The clearance provided between the needle and the blade point of the hook is 0.01 to 0.04 mm (when the needle is rocked to the right of the hole in the throat plate)
- 3) Adjustment value of the needle guard is 0 to 0.02 mm (needle is in the central section of the hole in the throat plate).

Adjustment Procedures	Results of Improper Adjustment														
<p>1. Enter timing gauge [1] ❶ supplied with the machine as accessories between the throat plate and the lower end of the needle bar as shown in the figure, fit the needle bar to timing gauge [1] ❶, loosen the setscrew ❷ in the needle bar connection, and adjust the height of the needle bar.</p> <p>(Caution) Adjust the height of the needle bar when the needle is positioned in the center of the needle hole in the throat plate.</p> <p>2. Table of timing gauge</p> <table border="1" data-bbox="172 712 893 855"> <thead> <tr> <th rowspan="2">Sub-class type</th> <th colspan="2">Timing gauge</th> <th rowspan="2">Engraved mark</th> </tr> <tr> <th>[1]</th> <th>[2]</th> </tr> </thead> <tbody> <tr> <td>S (standard)</td> <td>12.0 mm</td> <td>14.5 mm</td> <td>79NS1</td> </tr> <tr> <td>K (knits)</td> <td>11.3 mm</td> <td>14.3 mm</td> <td>791K</td> </tr> </tbody> </table> <p>Part No. of timing gauge : 13943402 (S : standard) 13782107 (K : knits)</p>	Sub-class type	Timing gauge		Engraved mark	[1]	[2]	S (standard)	12.0 mm	14.5 mm	79NS1	K (knits)	11.3 mm	14.3 mm	791K	<ul style="list-style-type: none"> ○ For the floppy fabrics, it is effective when the needle bar is slightly lowered than the standard value.
Sub-class type		Timing gauge			Engraved mark										
	[1]	[2]													
S (standard)	12.0 mm	14.5 mm	79NS1												
K (knits)	11.3 mm	14.3 mm	791K												

Adjustment Procedures	Results of Improper Adjustment
<p>1. Turn the hand pulley in the normal direction of rotation, and make a state that the needle is in the center of hole in the throat plate and the needle bar starts going up from the lowest dead point. Then enter timing gauge [2] ❶ between the throat plate and the lower end of the needle bar as shown in the figure and loosen setscrew ❷ in the hook shaft joint to adjust the timing.</p> <p>2. Loosen setscrew ❷ in the hook shaft joint and adjust so that the clearance between the needle and the blade point of the hook is 0.01 to 0.04 mm when the needle is rocked to the extreme right of the hole in the throat plate.</p> <p>3. Adjust with setscrew ❸ so that the engagement of the top end of bobbin case positioning stopper ❹ and inner hook ❺ is 0 to 0.2 mm.</p> <p>4. Bend the needle guard and adjust so that the clearance between the needle and the needle guard is 0 to 0.02 mm.</p> <p>(Caution)</p> <ol style="list-style-type: none"> 1. When adjusting the needle guard, adjust so that there is no clearance between the inner hook presser and the rear plate. 2. When moving the needle guard to the needle side, put a screwdriver from the direction of the arrow mark, while pressing the loop guide, and perform the adjustment. 	<ul style="list-style-type: none"> ○ For the floppy fabrics, it is effective when the hook timing is slightly retarded than the standard value. (Clearance provided between the upper end of the needle eyelet and the blade point of the hook is desired to be approximately 1.0 mm.) ○ For the purl stitching, if the hook timing is advanced, crest of seam is likely to be improved. On the contrary, if the hook timing is retarded, stitch skipping is improved, but crest of seam is likely to be slightly deteriorated.

(3) Adjusting the feed timing belt tension

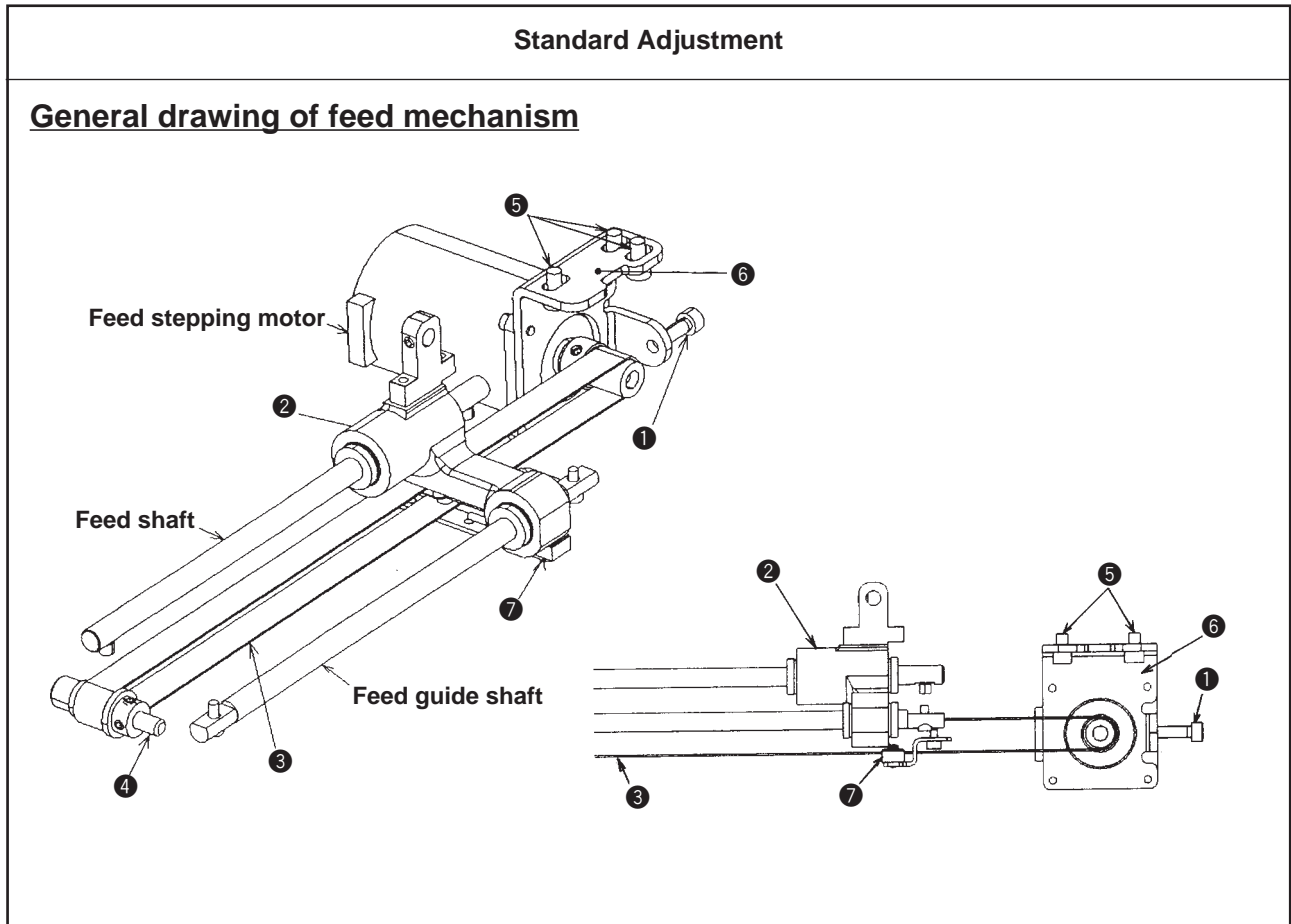

(4) Knife drop position

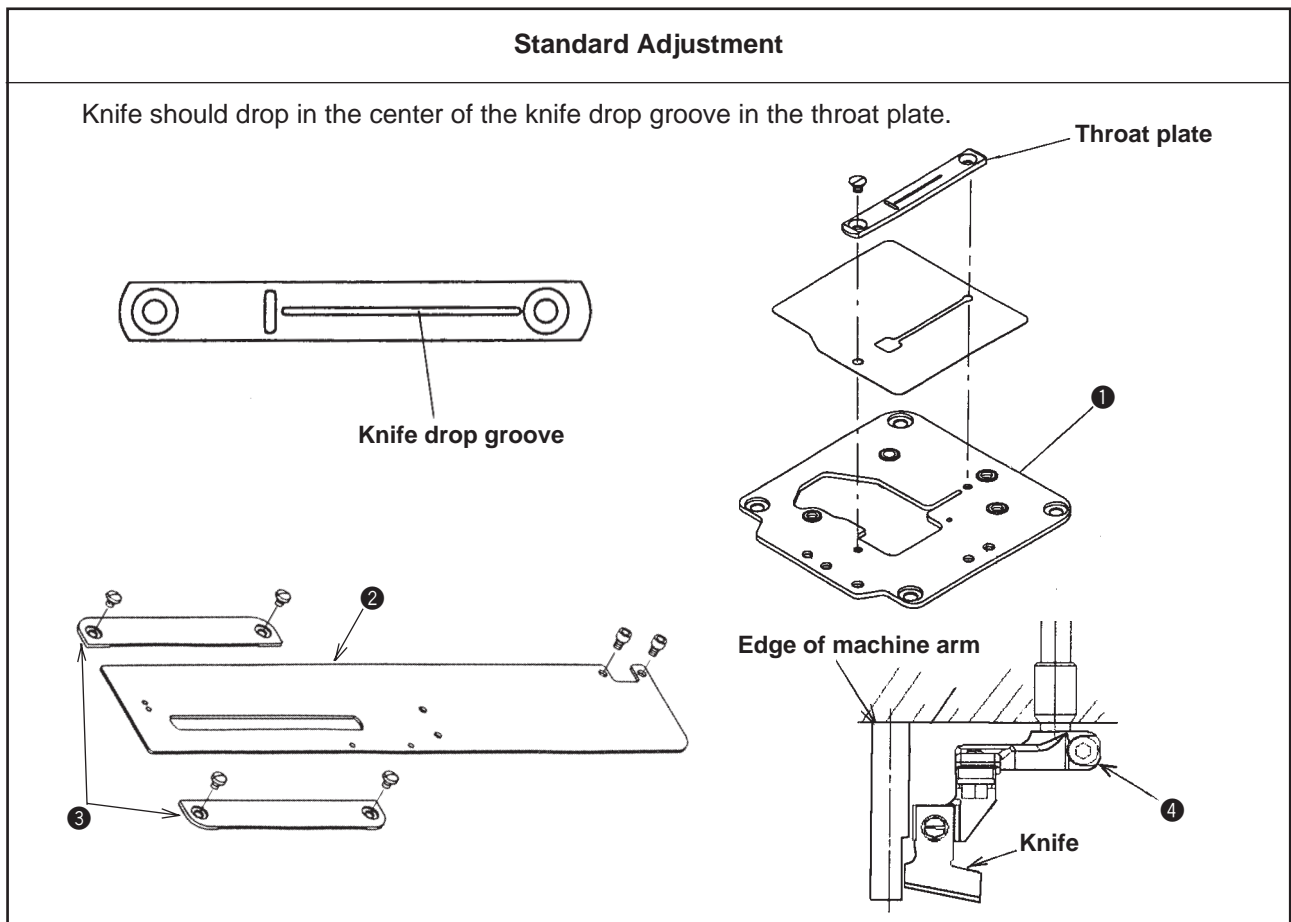

Adjustment Procedures	Results of Improper Adjustment
<p>1. Adjust the position of feed motor installing plate ⑥ so that the lengthwise feed timing belt tension is applied with 70 to 80N.</p> <p>2. Temporarily tighten three setscrews ⑤ in feed motor installing plate ⑥ and adjust the timing belt tension by taking adjusting screw ① in and out.</p> <p>(Caution)</p> <ol style="list-style-type: none"> 1. Be careful that timing belt ③ is not drawn up to one direction when feed base ② is moved back and forth several times. 2. Be careful that the cord of feed sensor ⑦ does not come in contact with timing belt ③. 3. Fix feed motor installing plate ⑥ so that feed follower shaft ④ is parallel to the lengthwise feed motor shaft. 	<ul style="list-style-type: none"> ○ When the belt tension is low, correct lengthwise feed pitch may not be obtained, or tooth-skipping of belt may occur.

Adjustment Procedures	Results of Improper Adjustment
<p>1. Loosen the setscrews, and remove work clamp carrier ② and throat plate base cover ③.</p> <p>2. Adjust the longitudinal and lateral positions at the installing position of throat plate base ① and the direction of rotation at the installing position of knife bar base ④.</p> <p>(Caution) When the installing position of throat plate base ① is adjusted, check the bobbin thread trimmer.</p>	<ul style="list-style-type: none"> ○ When the position is improper, the blade of cloth cutting knife will wear out earlier.

(5) Adjusting the stroke and initial position of the cloth cutting knife

Standard Adjustment

General drawing of cloth cutting knife

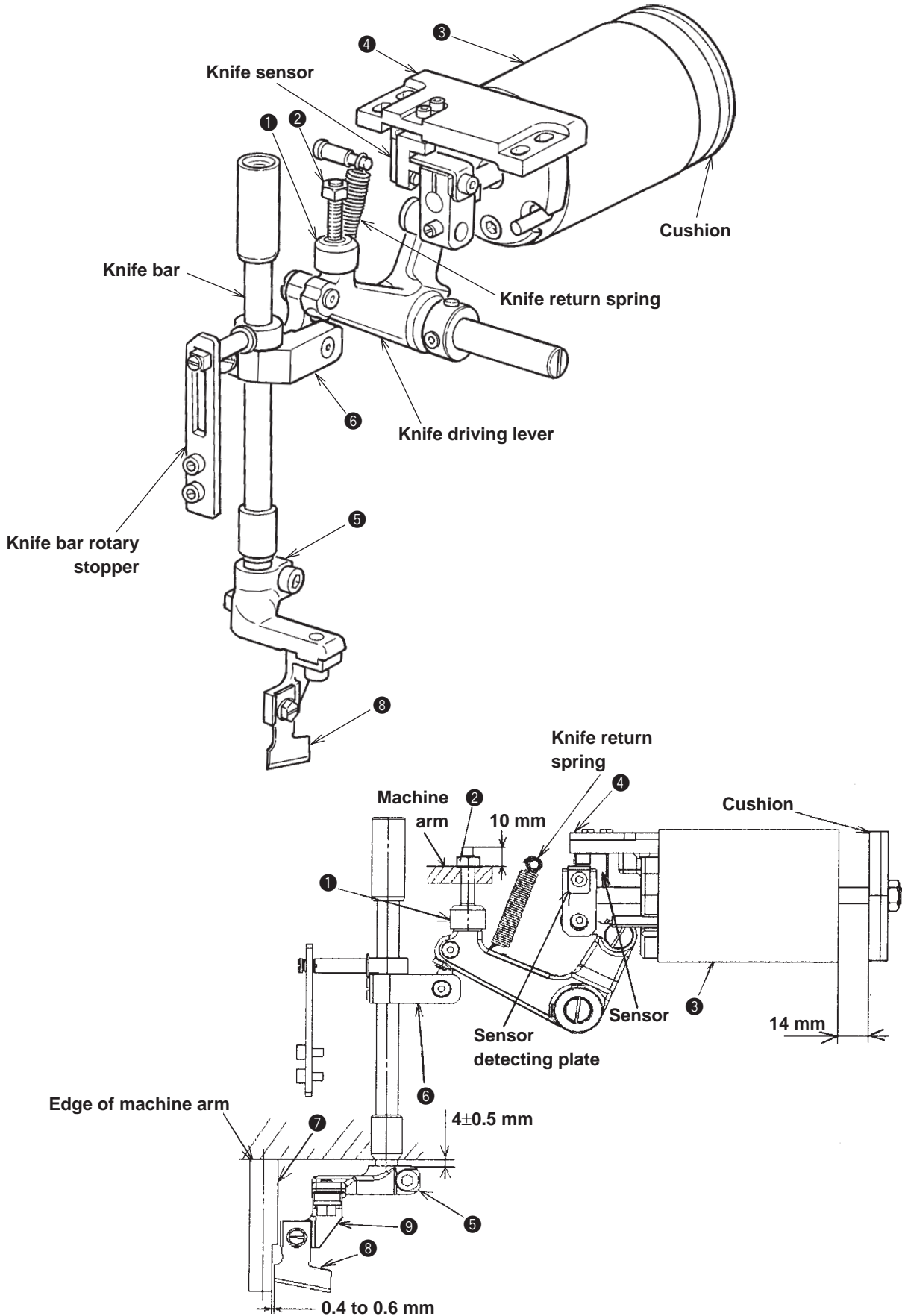

Adjustment Procedures	Results of Improper Adjustment
<p>1. Make the height of knife return stopper ① 10 mm from the work plane of the machine arm and fix it with nut ②. (Adjustment of initial position of the knife)</p> <p>2. Adjust the position of solenoid installing base ④ so that the clearance between cloth cutting knife solenoid ③ and the cushion is 14 mm, and fix it with four screws. (Adjustment of stroke)</p> <p>3. Fix knife bar bracket ⑥ so that the clearance between knife bar base ⑤ and the edge of the machine arm is 4 ± 0.5 mm. (Adjustment of initial position of the knife)</p> <p>4. Adjust knife installing base ⑨ so that the clearance between needle bar ⑦ and knife ⑧ is 0.5 ± 0.1 mm.</p> <p>(Caution)</p> <ol style="list-style-type: none"> 1. Be careful of the clearance between the throat plate and knife ⑧ when adjusting knife bar bracket ⑥, knife bar base ⑤ and knife installing base ⑨. 2. Fix solenoid installing base ④ so that it is not tilted. 	<ul style="list-style-type: none"> ○ If the distance of 4 mm is excessively small, the knife installing base comes in contact with the jaw section of the machine arm and a big noise occurs. ○ If the distance of 4 mm is excessively large, the knife may come out under the presser when the presser is lifted. ○ If the distance between cloth cutting knife and needle bar is small, the knife comes in contact with needle bar and abnormal noise, worn-out of knife or stain of cloth may occur. ○ If the distance between cloth cutting knife and needle bar is large, the distance from the front bar-tacking to knife hole is increased and the rear bar-tacking may be cut.

(6) Adjusting the rotary play of the cloth cutting knife

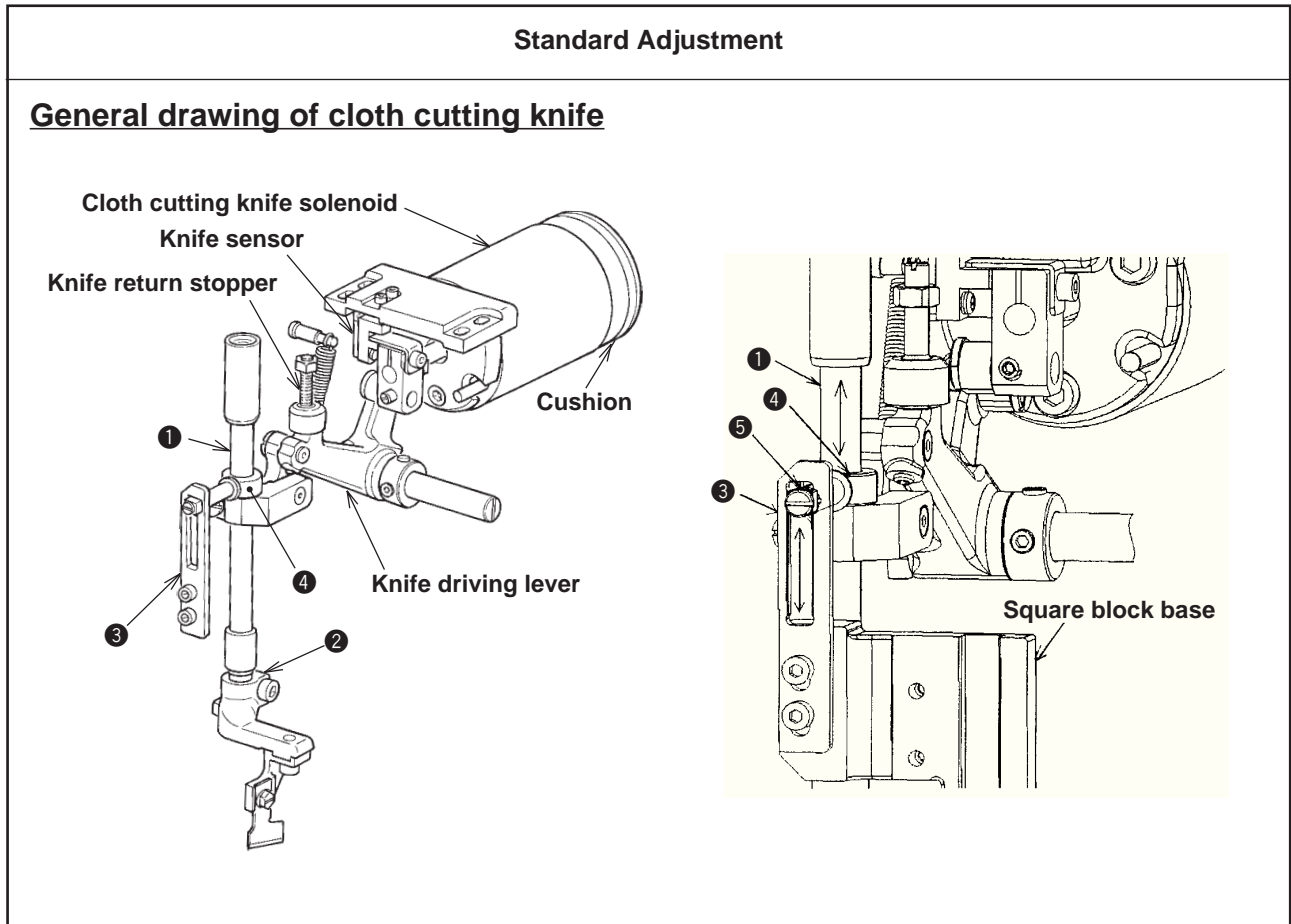

(7) Replacing the knife

Standard Adjustment

The diagram illustrates the steps for replacing the knife. Callout 1 indicates the knife holder assembly, and callout 2 indicates the knife. An inset shows the knife being inserted into the holder, with a dimension line indicating a gap of 1 to 2 mm between the knife and the holder.

Inch → mm conversion table

Knife size (inch indication)	mm indication
1/4	6.40
3/8	9.50
7/16	11.10
1/2	12.70
9/16	14.30
5/8	15.90
11/16	17.50
3/4	19.10
13/16	20.60
7/8	22.20
1	25.40
1-1/8	28.60
1-1/4	31.80

Adjustment Procedures	Results of Improper Adjustment
<p>1. Fix knife bar rotary stopper ③ and the setscrew of thrust collar ④ (from the left side of the machine arm) so that when moving knife bar ① up or down, it moves smoothly and there is no rotary play at knife bar base ②.</p> <p>(Caution) When moving knife bar ① up or down, check that there is a sufficient clearance between square block ⑤ and knife bar rotary stopper ③ both at upper and lower positions.</p>	<p>○ When the rotary play is large, the cloth cutting knife may interfere with the throat plate. This case is very dangerous. So, be careful.</p>

Adjustment Procedures	Results of Improper Adjustment
<p>When sharpening knife ① or replacing it with a new one ①, perform as follows.</p> <ol style="list-style-type: none"> 1. Loosen knife setscrew ②. Knife ① can be simply removed together with the washer. 2. Adjust so that the distance from knife ① and the top surface of the throat plate is 1 to 2mm when lightly lowering the knife bar by hand as shown in the figure. Then tighten it with the washer without fail. <p>When the cloth cutting knife ① you have is indicated by inch, set the cloth cutting length (knife size) to mm indication referring to the inch → mm conversion table.</p>	

(8) Adjusting the needle thread trimmer

Standard Adjustment

1) Adjusting the thread grasping force of the needle thread trimmer

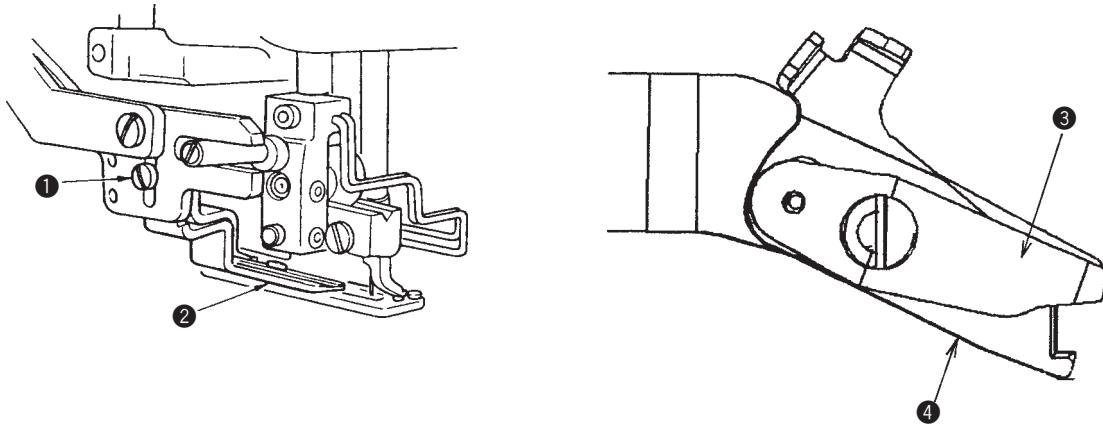

2) Adjusting the height of the needle thread trimmer

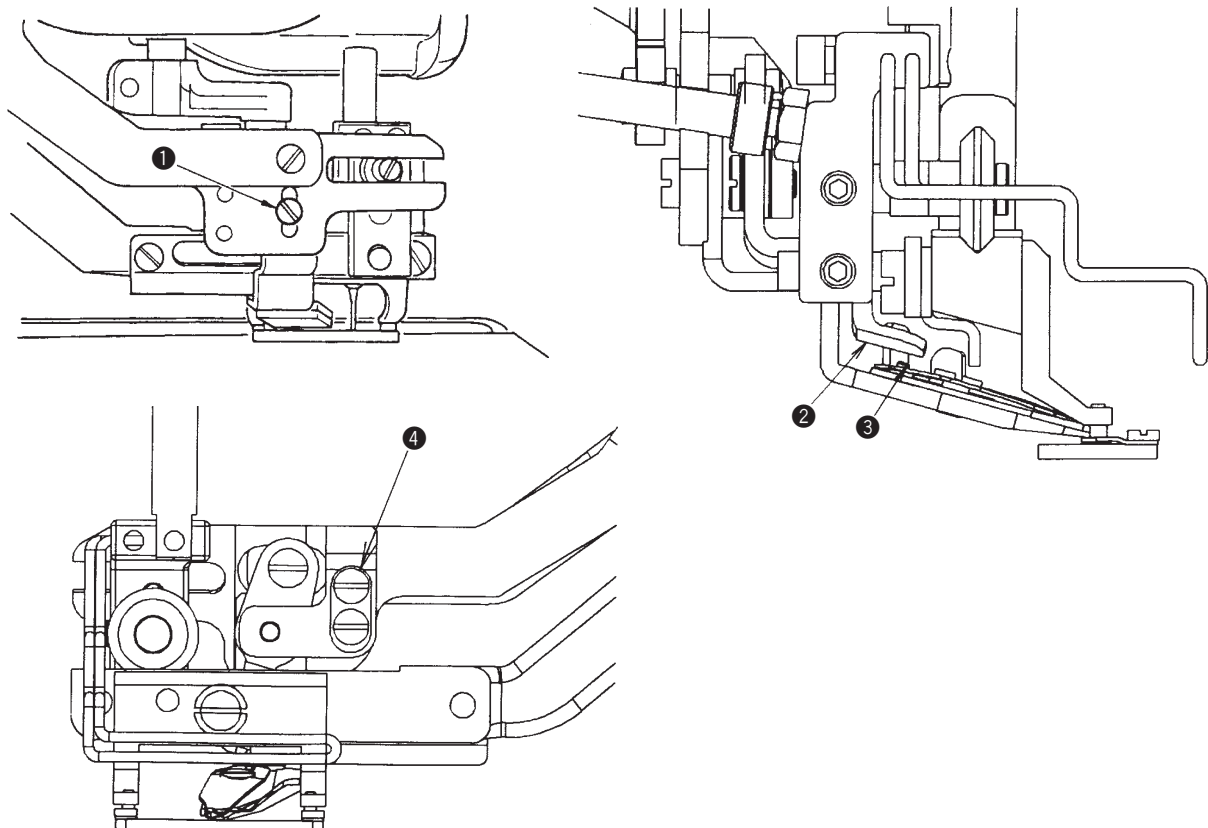

Adjustment Procedures	Results of Improper Adjustment
<ol style="list-style-type: none"> 1. If needle thread trimmer ② fails to provide consistent thread grasping force, loosen setscrew ① and remove needle thread trimmer ②. 2. Slightly bend the top end of thread presser spring ③ by hand so that it comes in contact with thread trimming blade of upper knife ④ over the length with no clearance and so that the needle thread trimmer securely holds the thread regardless of the position of the thread trimming blade at which the thread is trimmed. 	<ul style="list-style-type: none"> ○ When the thread grasping force of needle thread trimmer ② is low, slip-off of needle thread at the start of sewing or thread grasping failure after thread trimming occurs.
<ol style="list-style-type: none"> 1. Loosen setscrew ① in the needle thread trimmer and move the trimmer up or down to adjust the height. Set the clearance between the trimmer and the presser as low as possible, provided that they do not come in contact with each other, in order to minimize the length of remaining thread on the needle after trimming. 2. Note that the presser tilts when sewing a multi-layered portion of the material. Slightly raise the installing position of the trimmer so that the presser does not come in contact with the trimmer. 	<ul style="list-style-type: none"> ○ When the trimmer is set excessively high, trimmer open lever ② comes in contact with needle thread trimmer lower knife pin ③ when trimmer open lever ② is actuated, and malfunction may occur. In this case, loosen setscrew ④ and raise upward the height of trimmer open lever ② to prevent the contact.

Standard Adjustment



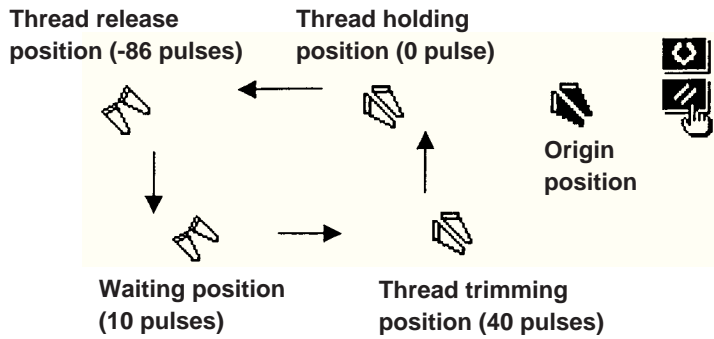





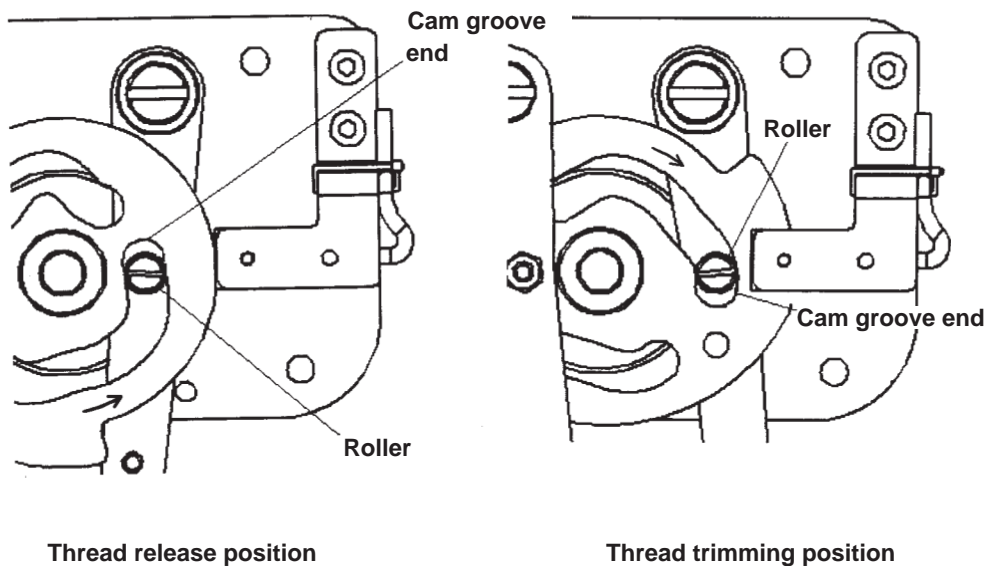
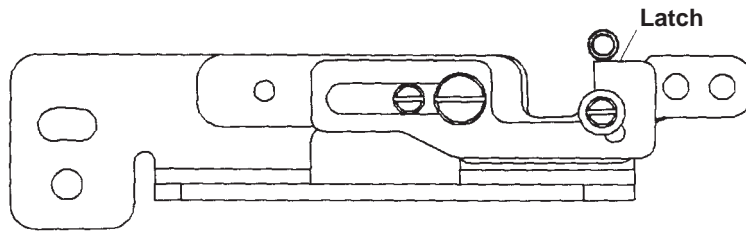



3) Needle thread trimming adjustment mode



* When entering the adjustment mode, the position is in the state of origin position.

Needle thread trimming adjustment mode motion



Adjustment Procedures	Results of Improper Adjustment
<ol style="list-style-type: none"> 1. Press MODE key 4  to enter memory switch level 2 of the adjustment mode. 2. Select K51 with ITEM SELECTION key 10   and press READY key 2 . 3. Every time ITEM SELECTION key 10   is pressed, the four positions as shown in the figure are repeatedly moved and can be changed over in order. 4. To change the set value, move the state to the position you desire to set, and set the value with DATA CHANGE key 11  . <ol style="list-style-type: none"> (1) Thread trimming position <ol style="list-style-type: none"> 1) Longitudinal position of the trimmer at the time of trimming can be changed. Locus of the trimmer in terms of needle thread scarcely changes and the position of trimmer after trimming only changes. When needle thread is missed, adjust it with “6) Longitudinal and lateral adjustment of the needle thread trimmer (at the time of trimming)”. (2) Thread holding position <ol style="list-style-type: none"> 1) Fine adjustment of the longitudinal position of trimmer at the start of sewing can be performed. (3) Thread release position <ol style="list-style-type: none"> 1) Escape amount of the trimmer can be adjusted. Adjust the opening amount of trimmer with “7) Opening amount of the needle thread trimmer”. (4) Waiting position <ol style="list-style-type: none"> 1) Trimmer waits before trimming thread after it is opened. The longitudinal position can be adjusted. 5. When READY key 2  is pressed, origin retrieval can be performed from any position and the position moves to the origin position. 6. When the starting pedal is depressed when the needle thread trimmer is in the thread holding position, the mode can be entered to the mode that the sewing can be performed with the needle thread trimming adjustment. When the mode has entered the mode that the sewing can be performed, set the cloth same as the ordinary sewing, and start the sewing with the starting pedal. A series of ordinary sewing motion is performed and the sewing machine stops immediately before needle thread trimming. Then press ITEM SELECTION key 10   and adjust the thread trimming motion. 7. When RESET key 3  is pressed, the respective moving set values are memorized in EEPROM of the machine head and the needle thread trimming adjustment mode is completed. 	<ul style="list-style-type: none"> ○ Thread trimming position When the number is excessively increased, the needle thread trimming cam groove end comes in contact with the roller, and step-out of needle thread trimming motor may occur. ○ Thread release position When the number is excessively decreased (minus number is increased), the needle thread trimming cam groove end comes in contact with the roller, and step-out of needle thread trimming motor may occur. ○ Waiting position When the number is excessively decreased, the latch comes off during sewing, trimmer and needle collide with each other, and needle breakage or trimmer breakage may occur. ○ Sewing with the needle thread trimming adjustment mode After the position is moved to the thread trimming position, bobbin thread trimming motion is automatically performed.

Standard Adjustment

4) Adjusting the needle thread trimmer origin sensor

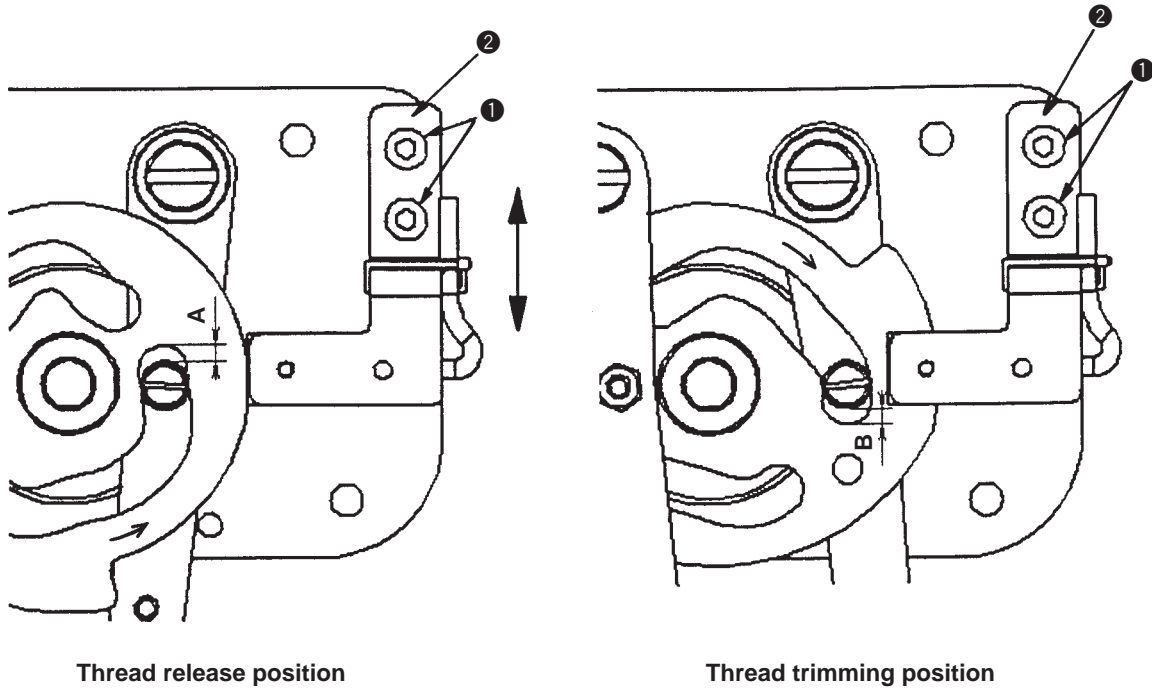

5) Lateral adjustment of the needle thread trimmer (start of sewing)

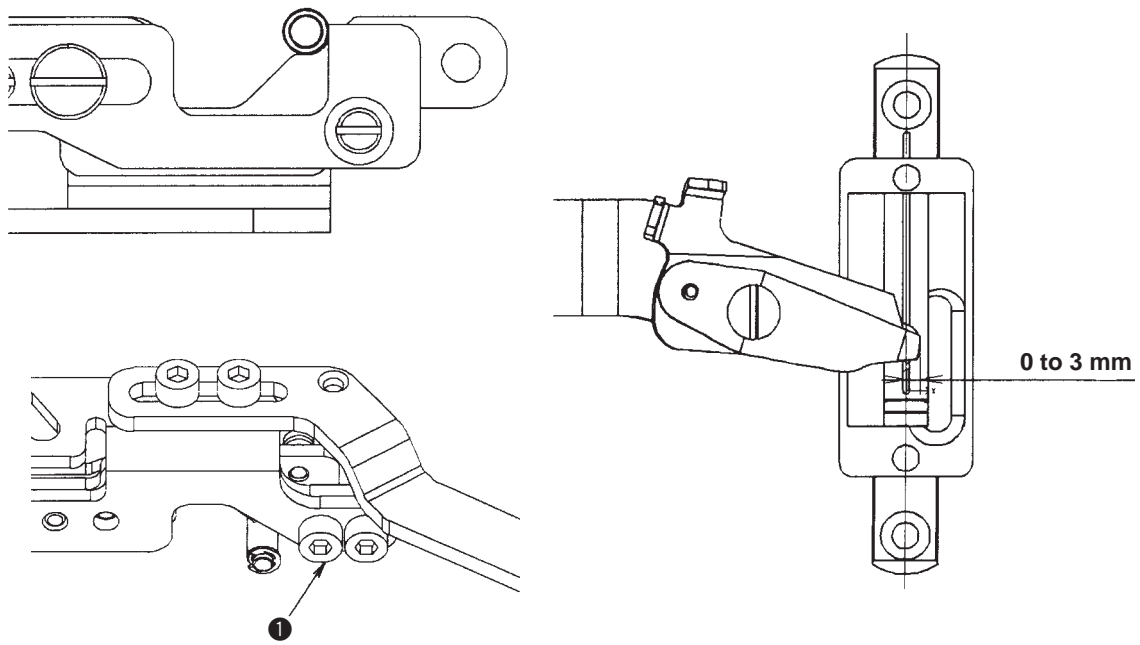

* Thread holding : "0" pulse

Adjustment Procedures	Results of Improper Adjustment
<ol style="list-style-type: none"> 1. Adjust the origin sensor with the respective initial data of thread releasing position (-86) and thread trimming position (40) referring to 3) Needle thread trimming adjustment mode. 2. Loosen setscrews ❶ in needle thread trimmer sensor installing plate ❷ and move needle thread trimmer sensor installing plate ❷ up or down so that A is almost equal to B when the motion of cam is maximized in each direction. 	<ul style="list-style-type: none"> ○ If A and B are not equal to each other, step-out of needle thread trimming motor may occur.
<ol style="list-style-type: none"> 1. Start up 3) Needle thread trimming adjustment mode and set the trimmer to thread holding position (0). 2. At the start of sewing, loosen setscrews ❶ and adjust so that the trimmer is placed 0 to 3 mm to the right from the center of knife groove. (Adjust in accordance with roll-in of needle thread.) 	<ul style="list-style-type: none"> ○ If the adjustment is improper, needle thread at the start of sewing protrudes from the seam.

Standard Adjustment

6) Longitudinal and lateral adjustment of the needle thread trimmer (at the time of trimming)

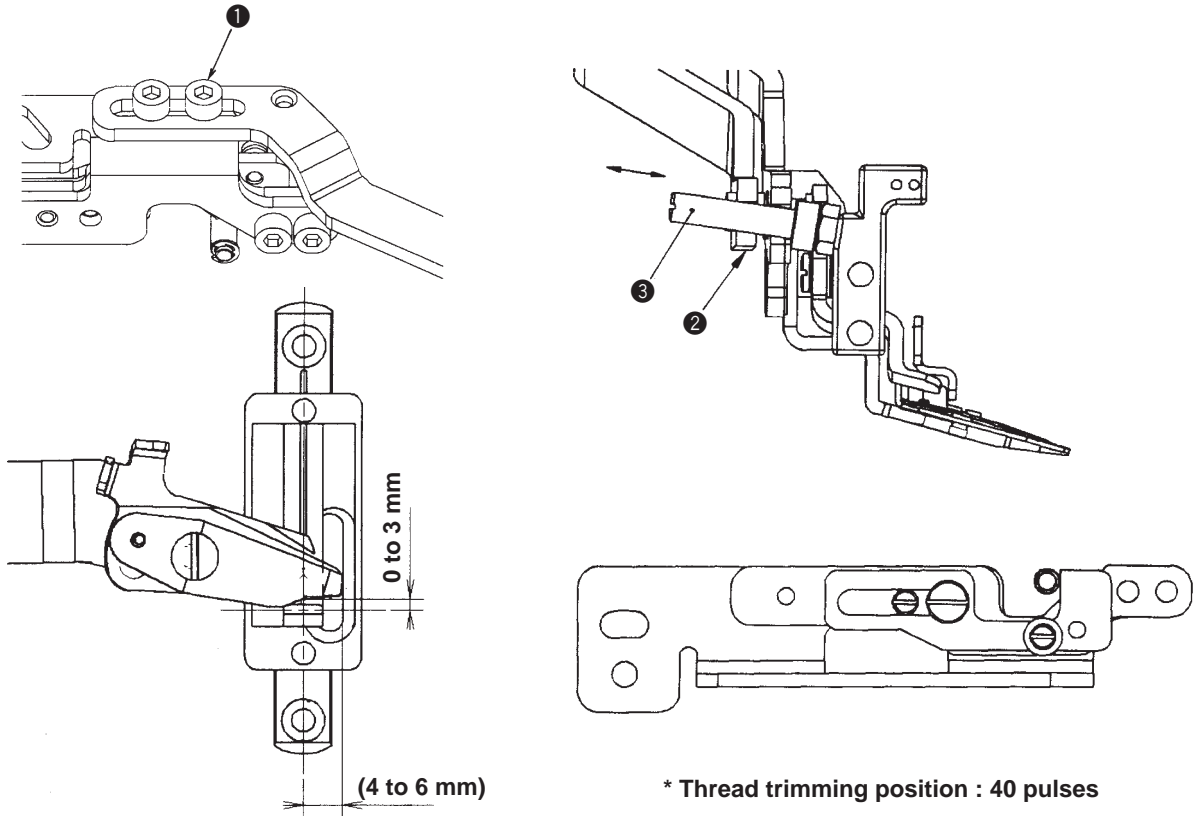

7) Opening amount of the needle thread trimmer

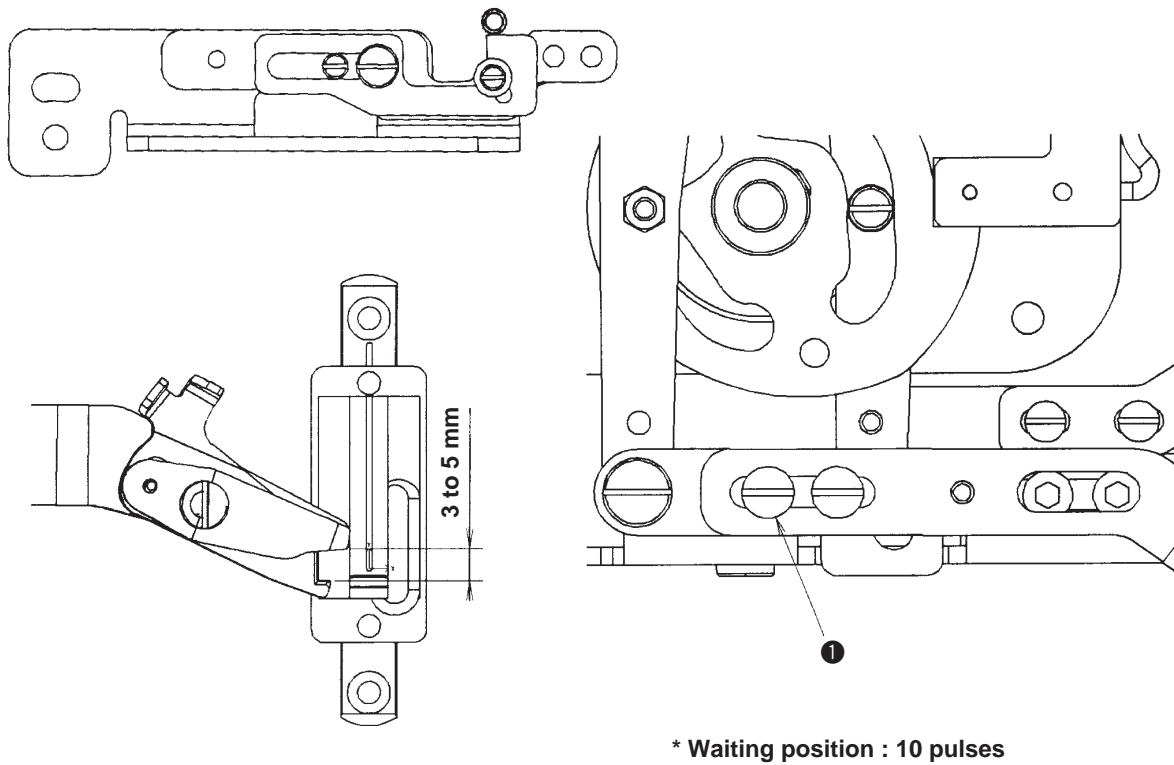

Adjustment Procedures	Results of Improper Adjustment
<ol style="list-style-type: none"> 1. Start up 3) Needle thread trimming adjustment mode and set the trimmer to thread trimming position (40). 2. Loosen setscrews ❶ and adjust so that the longitudinal position of the trimmer is set to 0 to 3 mm from the center of the needle hole at the time of needle thread trimming. 3. Adjust needle thread trimmer guide shaft ❸ in the direction of the arrow mark so that needle thread trimmer guide shaft ❸ comes in contact with arm B ❷ at the time immediately before the needle thread trimmer is fully closed. 	<ul style="list-style-type: none"> ○ If the adjustment is improper, needle thread is missed at the time of trimming and cannot be trimmed. Besides, the trimmed needle thread may not be caught.
<ol style="list-style-type: none"> 1. Start up 3) Needle thread trimming adjustment mode and set the trimmer to waiting position (10). 2. Loosen setscrews ❶ and adjust so that opening amount of the trimmer is 3 to 5 mm when the needle thread trimmer is in the waiting position during sewing. <p>(Caution) Check that the trimmer securely releases needle thread when it retreats to the extreme end. Increase the opening amount when needle thread is not released.</p>	<ul style="list-style-type: none"> ○ When the opening amount of trimmer is narrow, needle thread is not released at the start of sewing and needle thread may protrude. ○ When the opening amount of trimmer is narrow, needle thread may be missed at the time of trimming. ○ When the opening amount of trimmer is excessively large, the trimmer opens and needle thread may slip off when the presser is lifted. ○ When the opening amount of trimmer is excessively large, the trimmer exceeds the motion range and step-out of needle thread trimmer motor may occur.

Standard Adjustment

8) Adjusting the needle thread draw-in amount

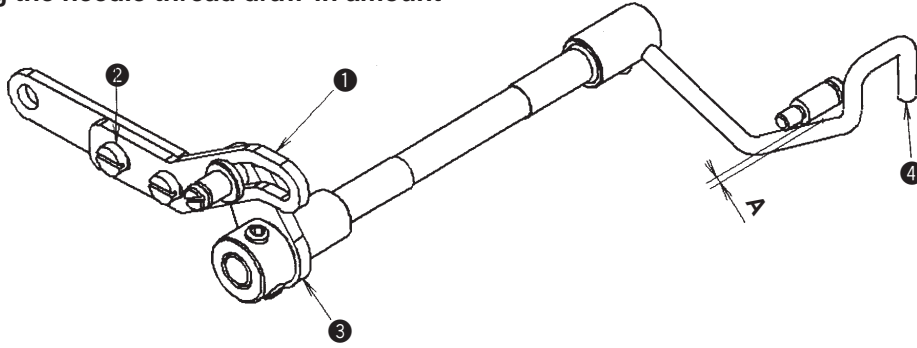

(9) Adjusting the bobbin thread trimmer

Standard Adjustment

1) Bobbin thread trimmer adjustment mode

K52 Bobbin thread trimmer adjustment mode

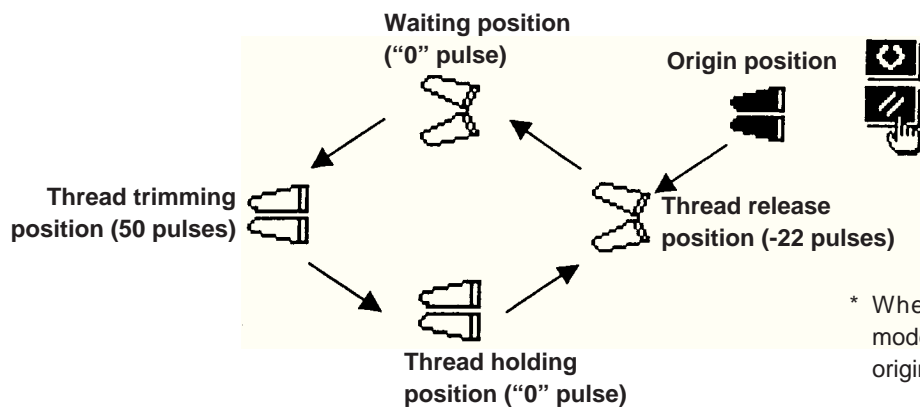

* When entering the adjustment mode, the position is in the state of origin position.

Bobbin thread trimmer adjustment mode motion

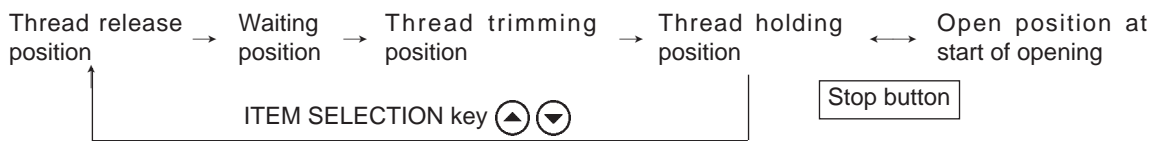

* Thread release position

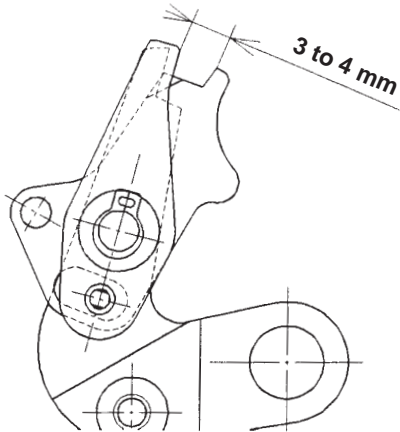





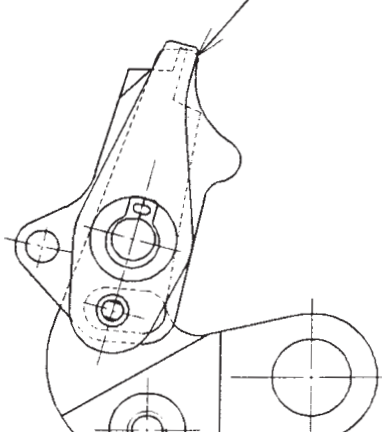





* Thread trimming position

To be almost flush



Adjustment Procedures	Results of Improper Adjustment
<ol style="list-style-type: none"> Loosen setscrews ② in draw-in link B ① and move needle thread draw-in arm ③ to adjust needle thread draw-in amount A (position of needle thread draw-in lever ④) at the time of needle thread trimming. Reference of adjustment is to adjust A to "0" when draw-in link B ① is assembled in the center of long hole and loosen setscrews ② in the direction of increasing the needle thread draw-in amount. 	<ul style="list-style-type: none"> When needle thread draw-in amount is excessively increased, or needle thread draw-in arm ③ is excessively tilted, malfunction occurs.

Adjustment Procedures	Results of Improper Adjustment
<ol style="list-style-type: none"> Press MODE key ④ M for approximately three seconds to enter memory switch level 2 of the adjustment mode. Select K52 with ITEM SELECTION key ⑩   and press READY key ②  to enter bobbin thread trimmer adjustment mode. Every time ITEM SELECTION key ⑩   is pressed, the four positions as shown in the figure are repeatedly moved and can be changed over in order. Thread release position → Waiting position → Thread trimming position → Thread holding position To change the set value, move the state to the position you desire to set, and set the value with DATA CHANGE key ⑪  . Adjust the thread release position so that the distance from the top end of lower knife to the holding spring is 3 to 4 mm. Adjust the thread trimming position so that the lower knife and the holding spring are almost flush with each other. When READY key ②  is pressed, origin retrieval can be performed from any position and the position moves to the origin position. When STOP button is pressed when the position is moved to the thread holding position, the position moves from the thread holding position to the open amount at the start of opening (value set with K21, initial value : 8). Then it can be checked that how much the bobbin thread trimmer opens when it starts opening at the start of sewing. Every time STOP button is pressed, the move between thread holding position and open amount at start of opening repeats. For the setting procedure, refer to "4) Open timing and open amount." In addition, when STOP button is pressed when the position is moved to the thread holding position, the speed of bobbin thread trimming motion can be changed. The speed is changed to the low speed (moving to the thread trimming position is at extreme low speed) by the first pressing of STOP button from the initial state. Every time STOP button is pressed, the speed of normal motion and the low speed alternate. When the starting pedal is pressed when the bobbin thread trimmer is in the thread holding position, the mode can be entered to the mode that the sewing can be performed with the bobbin thread trimmer adjustment. When the mode has entered the mode that sewing can be performed, set the cloth same as the ordinary sewing, and perform the sewing with the starting pedal. A series of ordinary sewing motion is performed, and the sewing machine stops immediately before needle thread trimming. Then press ITEM SELECTION key ⑩   and adjust the thread trimming motion. When RESET key ③  is pressed, the respective moving set values are memorized in EEPROM of the machine head and the bobbin thread trimmer adjustment mode is completed. 	<p>When the set value at each position is changed, it becomes as follows.</p> <ul style="list-style-type: none"> Thread release position (Initial value : -22 pulses) When the value is decreased, opening amount is increased. When the value is increased, it is decreased. When the trimmer is opened, be careful that the trimmer is not caught in the needle hole. When the opening amount is excessively small, bobbin thread may not be trimmed. Waiting position (Initial value : "0" pulse) Waiting position of the trimmer before thread trimming can be adjusted. When the set value is changed, the trimmer may interfere with needle. Thread trimming position (Initial value : 50 pulses) When the value is increased, overlapping of upper/lower knives of trimmer is increased and when it is decreased, the overlapping is decreased. When the value is excessively increased, thread holding after trimming bobbin thread cannot be performed. When the value is excessively decreased, the trimmer cannot be fully closed and thread is not trimmed. Thread holding position (Initial value : "0" pulse) Thread holding position at the start of sewing can be adjusted. When the set value is changed, the trimmer may interfere with needle. When the position is moved to the thread release position, move of the bobbin thread trimming release position is performed after automatically performing needle thread trimming.

Standard Adjustment

2) Adjusting the bobbin thread trimming origin sensor

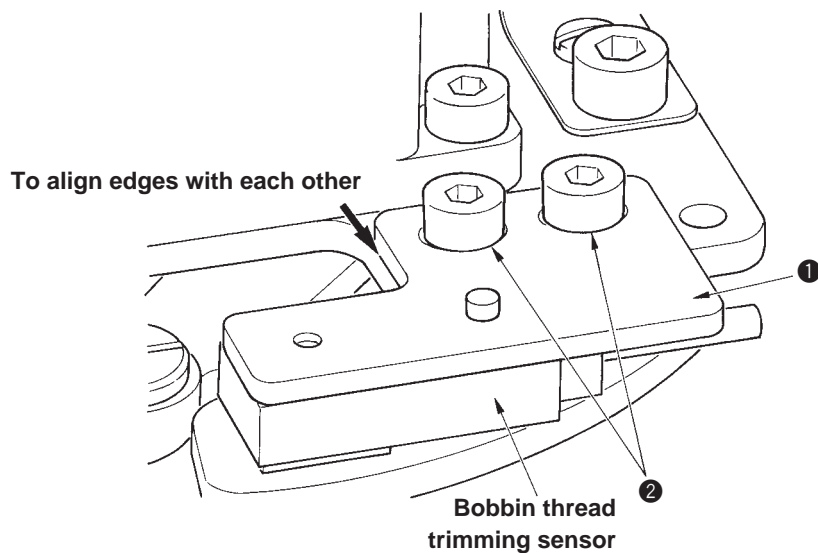

3) Adjusting the position of the trimmer

- Remove the hook and oil tank to adjust the position.

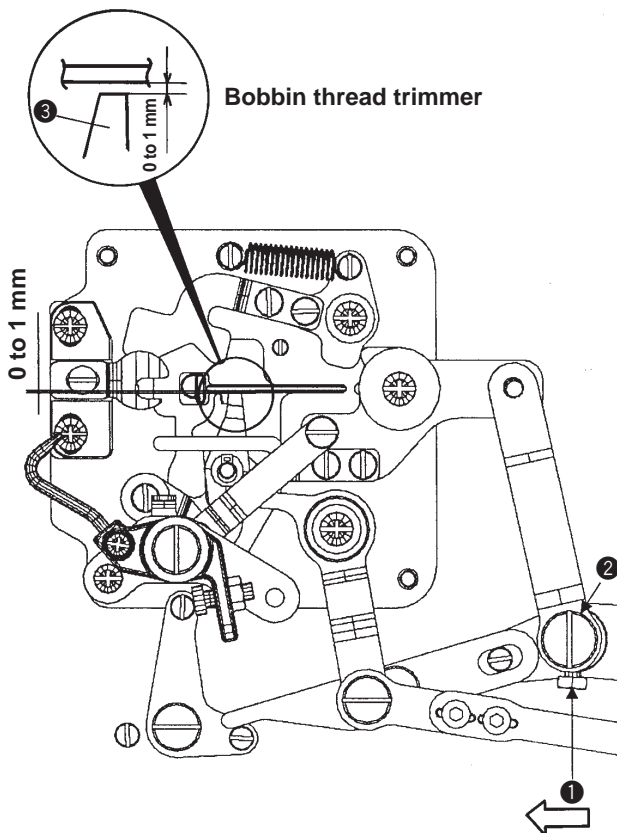

(Caution) Fix hexagon screw 1 when eccentric pin 2 is tilted in the direction of the arrow mark.

* Waiting position : "0" pulse

Adjustment Procedures	Results of Improper Adjustment
<p>Loosen setscrews ② in bobbin thread trimming origin detecting sensor installing plate ①, align the edges of the arrow mark in the figure with each other, and tighten setscrews ②.</p> <p>After assembling the sensor installing plate, check and adjust the motion referring to “(9) - 1) Bobbin thread trimmer adjustment mode”.</p>	
<ol style="list-style-type: none"> 1. Start up 1) Bobbin thread trimmer adjustment mode and set the trimmer to the waiting position. 2. When bobbin thread trimmer origin is detected, loosen hexagon screw ①, turn eccentric pin ②, and adjust so that the clearance between the top end of bobbin thread trimmer ③ and the knife groove of throat plate is 0 to 1 mm. Then tighten hexagon screw ①. 3. When the position of eccentric pin ② is changed, check the motion and perform the adjustment referring to 1) Bobbin thread trimmer adjustment mode. 	<ul style="list-style-type: none"> ○ When the distance from bobbin thread trimmer ③ to the knife groove is large, the trimmer may not be fully closed. ○ When the distance from bobbin thread trimmer ③ to the knife groove is small, the trimmer comes in contact with the cloth cutting knife and may be broken at the time of knife dropping.

Standard Adjustment

4) Replacing the bobbin thread trimmer

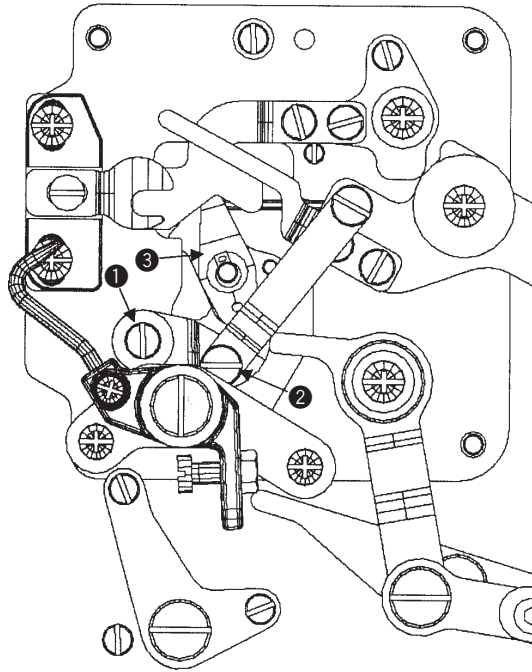

5) Open timing and open amount

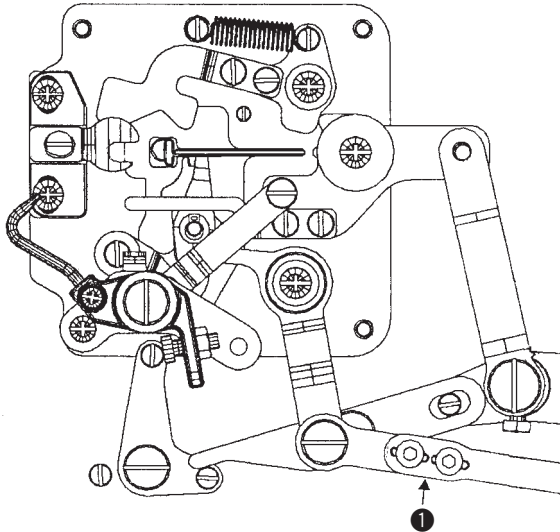

Conditions : Fix bobbin thread trimmer working link ① in the center of the long hole.

○ Thread holding position

Clearance between bobbin thread trimmer upper knife pin ② and bobbin thread working arm ③ is 0.5 to 1.5 mm.

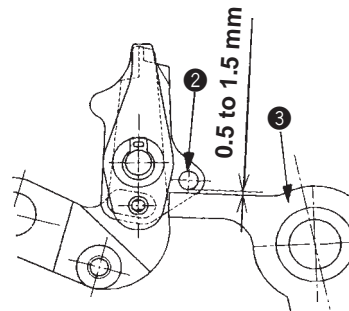



○ Open amount at start of opening

Overlapping amount (arrow mark section) of the top end of bobbin thread trimmer upper knife ④ and holding spring ⑤ is almost "0".

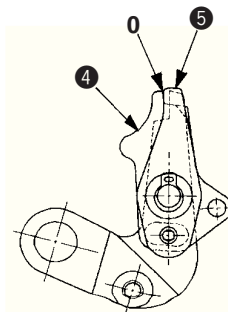
K21 Open amount of bobbin thread trimmer at sewing start Initial value : 8 (Memory switch level 2)



Adjustment Procedures	Results of Improper Adjustment
<p>1. Put the sewing machine in the bobbin thread trimming adjustment mode with level 2 K52 of memory switch. Refer to “1) Bobbin thread trimmer adjustment mode”.</p> <p>2. Put the position to thread trimming position (state in the figure on the left side) with ITEM SELECTION key 10   . Remove setscrews 1 and 2, and replace bobbin thread trimmer 3.</p> <p>(Caution) After replacing the bobbin thread trimmer 3, check the motion with “1) Bobbin thread trimmer adjustment mode”.</p>	
<p>1. Start up 1) Bobbin thread trimmer adjustment mode.</p> <p>2. Assembling parts</p> <p>(1) Making the center of the long hole of bobbin thread trimmer working link 1 as the reference, adjust thread holding position and open amount at the start of opening position and, fix them.</p> <p>3. Bobbin thread trimmer motion at the start of opening</p> <p>(1) After start of sewing, U24 (Bobbin thread trimmer motion start distance) feed moves and K21 (Bobbin thread trimmer release amount at sewing start) trimmer opens. After “Open amount at start of opening”, the trimmer gradually opens and it opens up to the release position of K52 (Bobbin thread trimmer adjustment mode).</p> <p>4. Adjustment with the operation panel</p> <p>(1) Open timing and open amount can be adjusted using the operation panel.</p> <ul style="list-style-type: none"> ○ Thread at the sewing start is not interlocked or when bobbin thread at the sewing start protrudes upward : ... Make the bobbin thread holding section longer. U24 +, K21 – ○ Seams at the sewing start are gathered cramped or when seams at the sewing start look stitch like skipping : ... Make the bobbin thread holding shorter. U24 –, K21 + <p>(Caution) Change the set value little by little because of delicate adjustment.</p>	<ul style="list-style-type: none"> ○ When bobbin thread is not held at the start of sewing, it does not interlace with needle thread and seams may not be formed. ○ When bobbin thread holding section is excessively long, seams are gathered and may look like stitch skipping. ○ When bobbin thread holding section is excessively short, bobbin thread at the sewing start may be drawn out to the upside.

(10) Adjusting the presser lifter

Standard Adjustment

1) Adjusting the backlash of the presser lifter gear

1. For the backlash of the presser lifter gear, adjust the installing position of presser lifter motor ① to remove the backlash.
2. Adjust so that backlash is 0.05 to 0.1 mm.

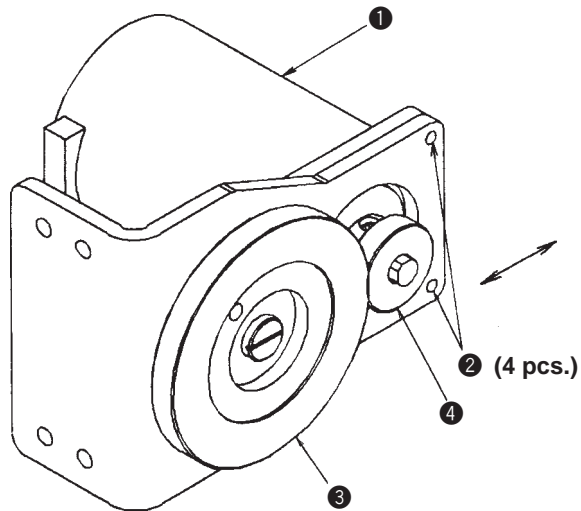

2) Adjusting the presser bar position bracket

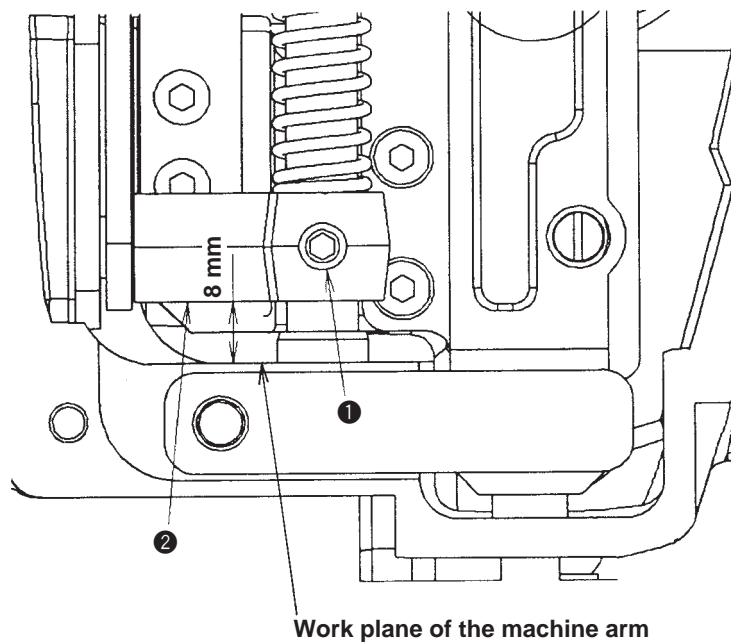

Adjustment Procedures	Results of Improper Adjustment
<ol style="list-style-type: none"> 1. Loosen four setscrews ② in the presser lifter motor, put a sheet of thin paper (approximately 0.05 mm thick) between gear, large ③ and gear, small ④, close the play, and fix four setscrews ② in the presser lifter motor to almost adjust the backlash. 2. After adjusting the backlash, apply grease to gear section of gear, large ③ and gear, small ④. 	<ul style="list-style-type: none"> ○ When backlash is large, presser foot lifting working noise increases. ○ When backlash is small, backlash is closed and malfunction occurs.
<p>Loosen setscrew ① in the presser bar position bracket when the presser is in the lowest position and adjust so that the height between presser bar position bracket ② and the work plane of the machine arm is 8 mm. Then tighten setscrew ① in the presser bar position bracket.</p>	

Standard Adjustment

3) Adjusting the presser lifter origin sensor

- ① Adjusting the sensor

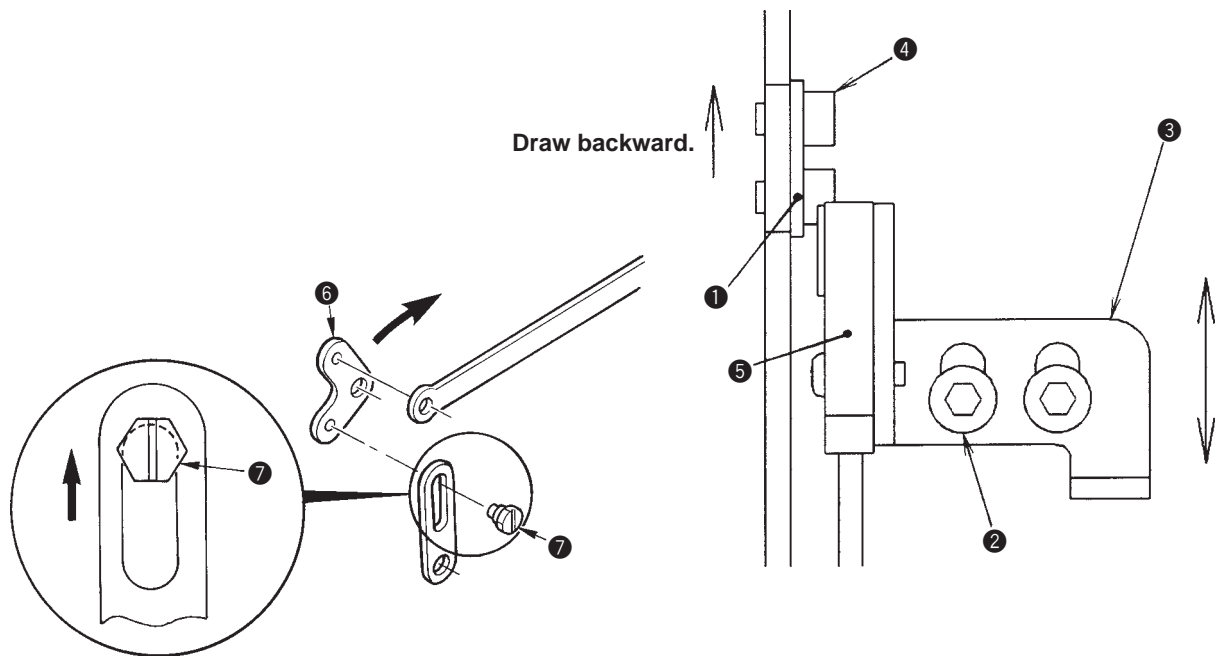

- ② Refer to the adjusting procedure of the presser lifter motor origin compensation

(11) Adjusting the thread tension

Standard Adjustment

1) Adjusting the stroke of the thread tension solenoid

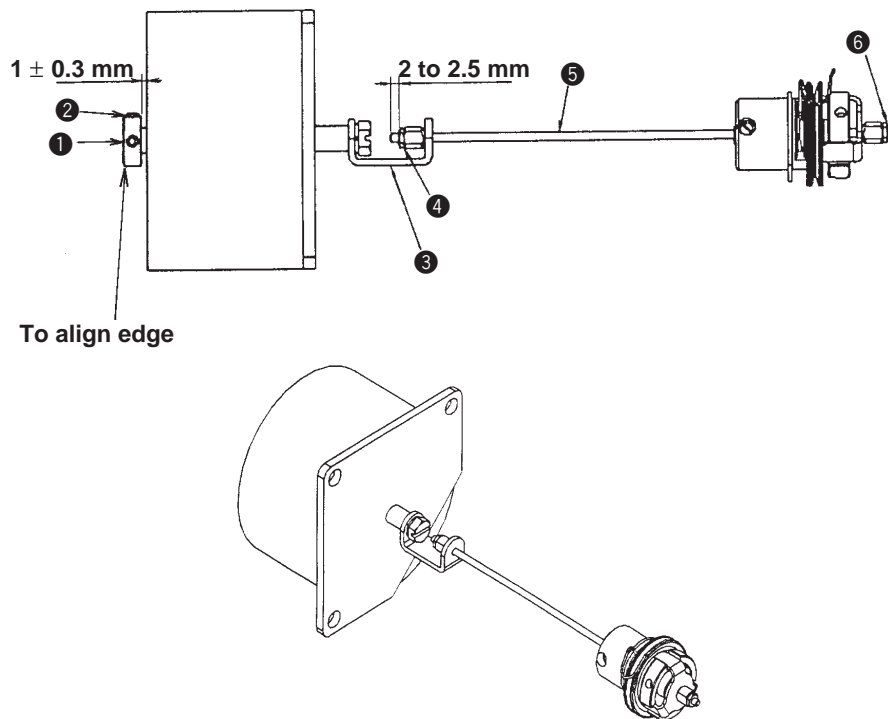

2) Adjusting the thread take-up spring tension (purl stitching)

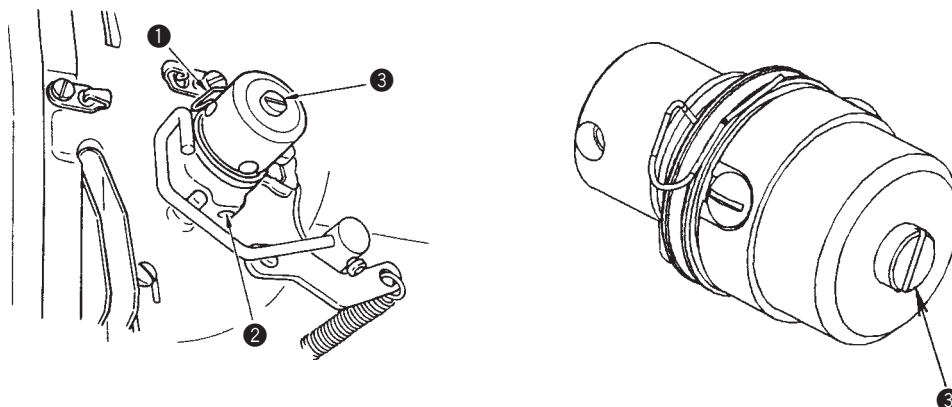

Adjustment Procedures	Results of Improper Adjustment
<ol style="list-style-type: none"> 1. Align shaft end ❶ of solenoid with the edge of thrust collar ❷. 2. Assemble thread tension connecting plate ❸ in the direction as shown in the figure. 3. Adjust so that thread tension connecting shaft ❺ protrudes by 2 to 2.5 mm from adjustment nut A ❹ and that stroke is 1 ± 0.3 mm using adjustment nut B ❻. 	<ul style="list-style-type: none"> ○ When the dimension value, 1 ± 0.3 mm is excessively improper, proper needle thread tension cannot be obtained and sewing failure occurs. ○ When the direction of thread tension connecting plate ❸ is improper, the plate comes in contact with the machine frame or the like and malfunction occurs.
<ol style="list-style-type: none"> 1. It is proper that thread take-up amount of thread take-up spring ❶ is 8 to 10 mm and that the strength of the start of moving is approximately 0.06 to 0.1N. 2. To change the moving amount of thread take-up spring ❶, loosen screw ❷, put a thin screwdriver in the slit of tension post ❸ and turn the screwdriver to adjust the moving amount of the thread take-up spring tension. 3. To change the strength of thread take-up spring ❶, put a thin screwdriver in the slit of tension post ❸ and turn the screwdriver in the state that screw ❷ is tightened. Turning clockwise increases the strength of thread take-up spring, and counterclockwise decreases the strength of the thread take-up spring. <p>(Caution) Assemble this thread tension after pressing until it will go no further.</p>	

(12) Adjusting the bobbin winder

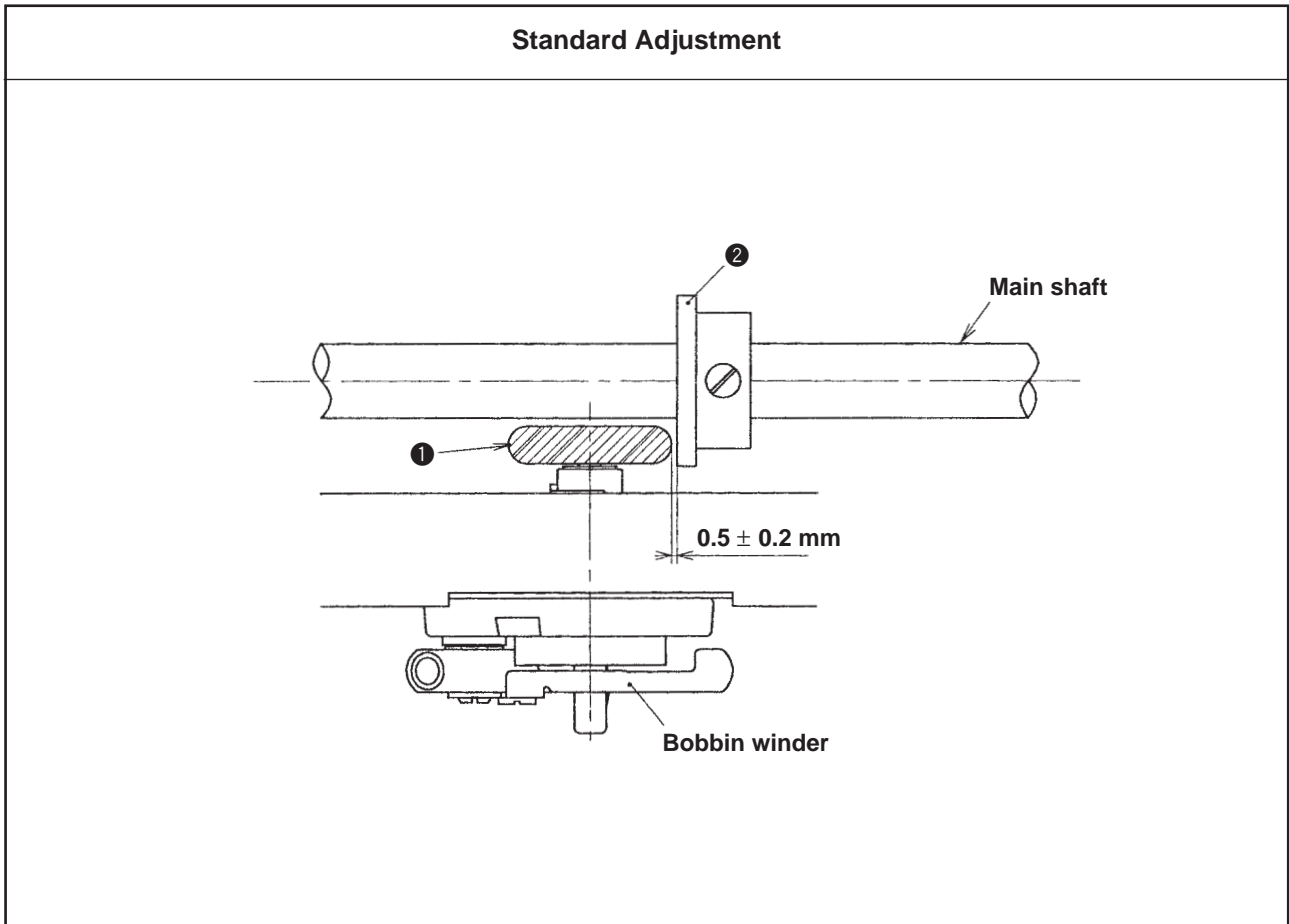

(13) Adjusting the thread breakage detecting plate

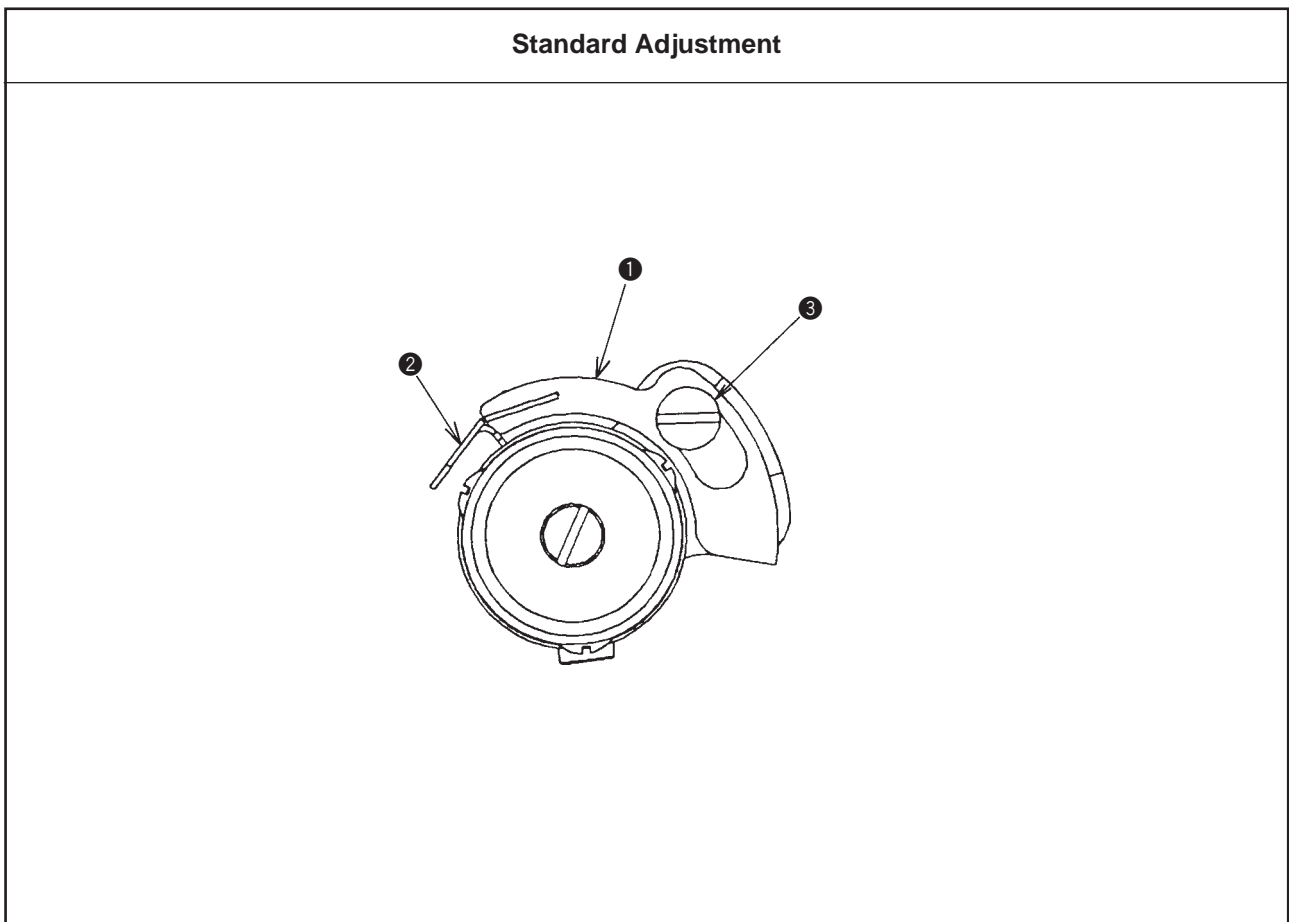

Adjustment Procedures	Results of Improper Adjustment
<p>Adjust and fix the position of bobbin winder driving wheel ② with the setscrew so that a clearance of 0.5 ± 0.2 mm is provided between rubber ring ① and bobbin winder driving wheel ② in the state that the bobbin thread is not wound.</p> <p>(Caution) When using the bobbin winder for a long period of time, rubber ring ① will wear down and slip. As a result, bobbin thread may not be wound. At this time, adjust and fix the position of bobbin winder driving wheel with the setscrew.</p>	<ul style="list-style-type: none"> ○ If the pressing pressure is low, rubber ring ① slips and bobbin thread may not be wound. ○ If the pressing pressure is high, wear of rubber ring ① is increased.

Adjustment Procedures	Results of Improper Adjustment
<ol style="list-style-type: none"> 1. Adjust so that thread breakage detecting plate ① comes in contact with thread take-up spring ② without fail when the machine head is not threaded. (Slack of the thread take-up spring has to be 0.5 mm.) 2. When the stroke of thread take-up spring ② has been changed, loosen screw ③ and be sure to adjust thread breakage detecting plate ①. <p>(Caution) Adjust so that thread breakage detecting plate ① does not come in contact with any metallic part (thread tension disk, etc.) other than thread take-up spring ②.</p>	<ul style="list-style-type: none"> ○ If the detecting plate does not come in contact with the spring, the needle thread breakage cannot be detected and the cloth cutting knife works. ○ If the contacting force is too strong, early breakage of the thread take-up spring ② will occur.

(14) Adjusting the bobbin presser

Standard Adjustment

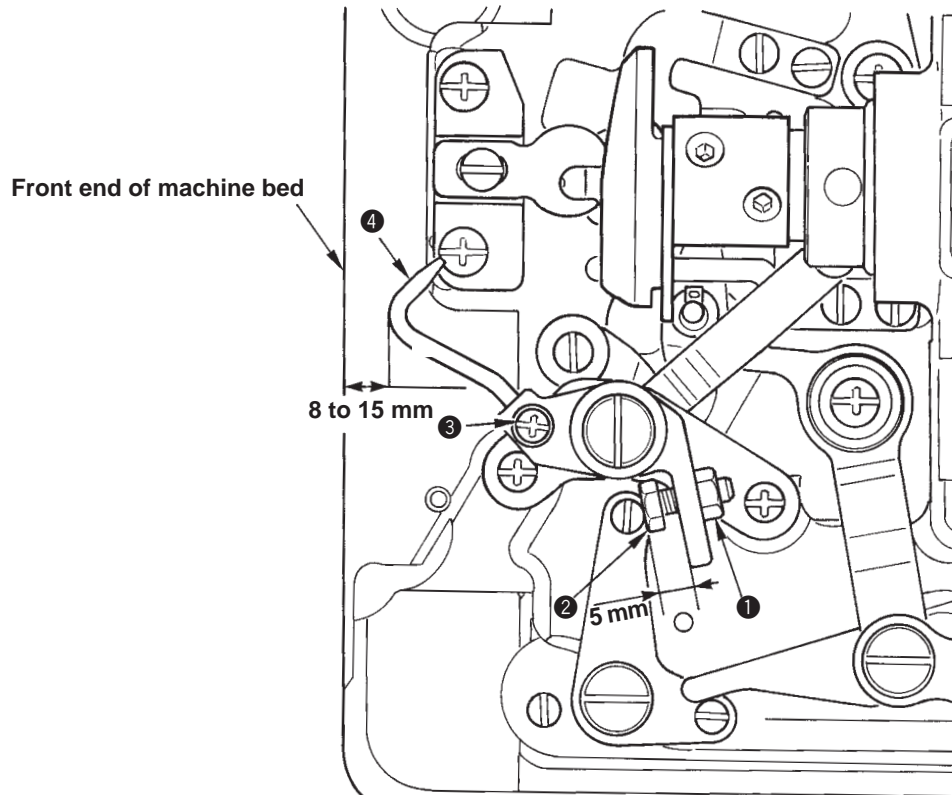

Adjustment Procedures	Results of Improper Adjustment
<p>1. Adjusting the waiting position of the bobbin presser Loosen nut ❶ and adjust the distance from screw ❷ to the bobbin presser base to 5 mm. Adjust so that the distance from the top end of bobbin presser ❸ to the front end of machine arm (dimension as shown in the figure) is 8 to 15 mm and tighten nut ❶. When the waiting position is near the hook, it is difficult to set or remove the bobbin case, and when the position is excessively away from the hook, the bobbin presser comes in contact with the hook cover.</p> <p>2. Adjusting the bobbin presser Loosen setscrew ❹ and adjust so that the top end of bobbin presser ❸ enters the hole of the bobbin case. Then tighten setscrew ❹. After the adjustment, check that the top end of bobbin presser ❸ enters the hole of the bobbin case when the bobbin thread trimmer is in the working state.</p>	

(15) Adjusting the pedal

Standard Adjustment

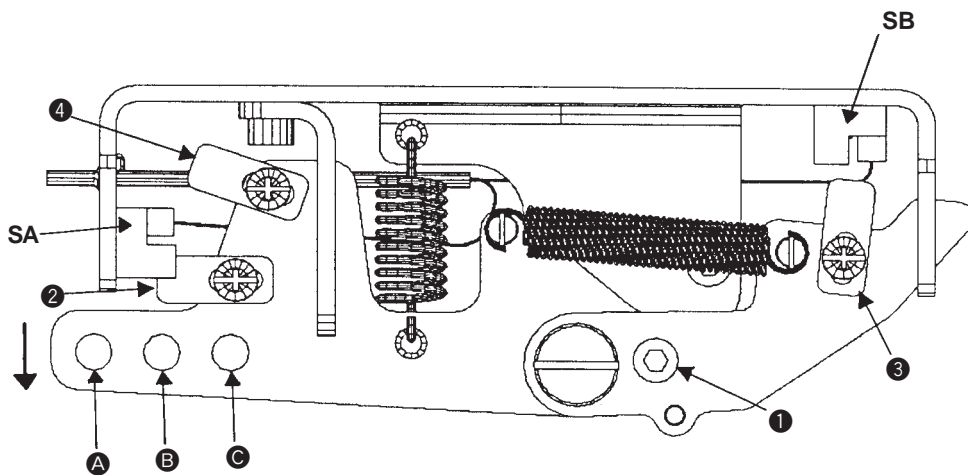

Pedal

- 2-pedal • 1-pedal
(Without intermediate position)
- 1-pedal
(With intermediate position)

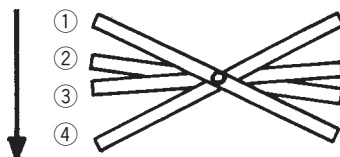

- ① : Maximum position
- ② : Intermediate position
- ③ : Cloth setting position
- ④ : Sewing position

	SA	SB
①	ON	OFF
②	OFF	OFF
③	OFF	ON
④	ON	ON

Adjustment Procedures	Results of Improper Adjustment
<p>Adjusting of the pedal in accordance with the pedal type setting Attach or remove setscrew ❶ in accordance with the setting of memory switch level 2 K01.</p> <ul style="list-style-type: none"> ○ 2-pedal and 1-pedal (without intermediate position) → Attach setscrew ❶. ○ 1-pedal (with intermediate position) → Remove setscrew ❶. <p>Adjusting the pedal stroke Pass the pedal connecting rod through hole ❷ in the center. When the rod is passed through hole ❸ which is far from the center, the whole pedal stroke is increased, and when it is passed through hole ❹ which is near the center, the stroke is decreased.</p> <p>Fine adjustment of the pedal stroke The pedal stroke can be finely adjusted by changing the position of the detecting plate of the sensor.</p> <p>Detecting plate ❺ The play at the start of depressing the pedal can be adjusted in case of using 1-pedal type. When detecting plate ❺ is lowered, the play is decreased, and when it is raised, the play is increased.</p> <p>Detecting plate ❻ Starting in case of using 2-pedal and 1-pedal (without intermediate position) types and lowering the presser in case of 1-pedal (with intermediate position) type can be adjusted. When detecting plate ❻ is raised, timing is advanced and when it is lowered, timing is retarded.</p> <p>Detecting plate ❼ Starting timing of 1-pedal (with intermediate position) type can be adjusted. When detecting plate ❼ is raised, timing is advanced, and when it is lowered, timing is retarded.</p>	

4. ADJUSTING EACH SENSOR

(1) Adjusting the needle rocking origin

Standard Adjustment

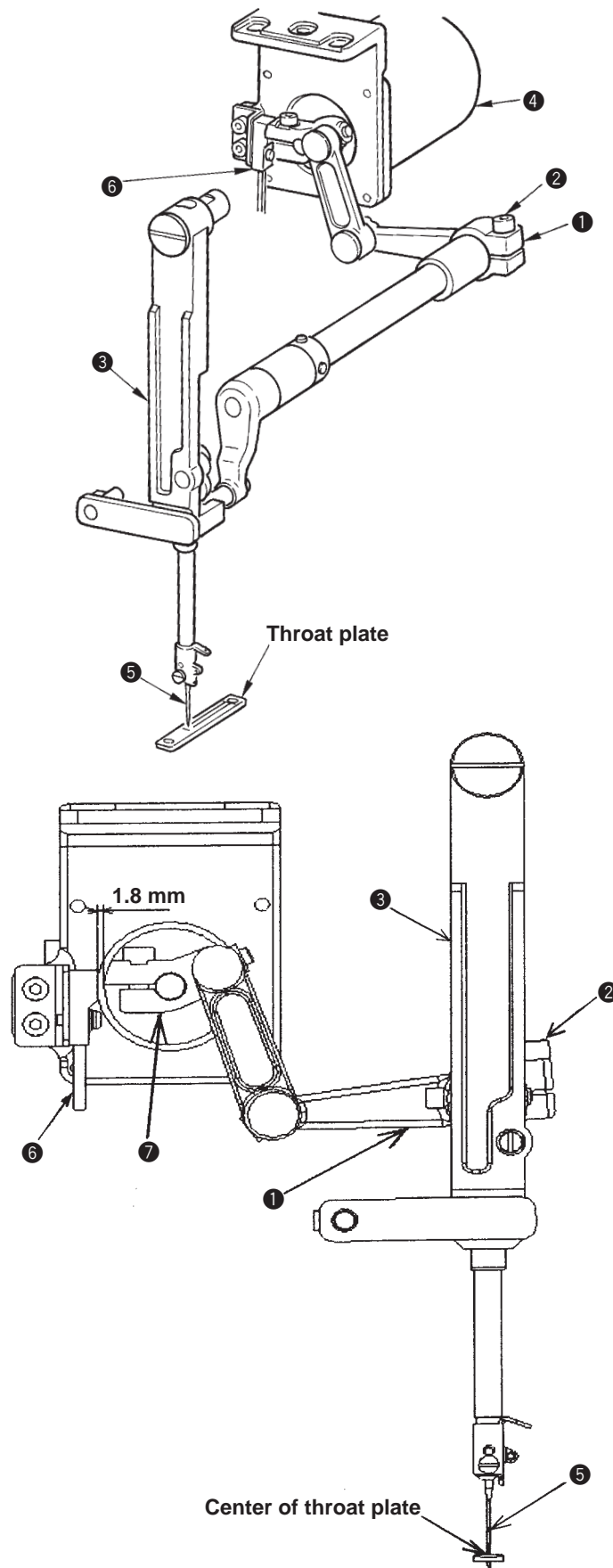

Adjustment Procedures	Results of Improper Adjustment
<p>(1) Adjusting the needle rocking origin</p> <ol style="list-style-type: none"> Origin of needle rocking stepping motor ④ can be adjusted with memory switch level 2 K16. Loosen setscrew ② in needle bar rocking lever, rear ①, and make a state that needle bar rocking frame ③ can move freely to the right and left. Then fix setscrew ② so that needle ⑤ is in the center of the throat plate when the panel set value is "0". <p>(Caution)</p> <ol style="list-style-type: none"> Check that the clearance between needle rocking sensor ⑥ and motor lever ⑦ is 1.8 mm. When loosening setscrew ② in needle bar rocking lever, rear ①, remove the bobbin winder unit. <ol style="list-style-type: none"> Mechanical adjustment is performed in the aforementioned procedure. However, as a matter of fact, perform compensation so that the center of the knife groove is equal to the right and left in the state that seams are formed. (Compensation can be performed up to 20 pulses (-10 to 10) = 1 mm to the right or left.) When the knife groove width on the right side is larger, perform compensation to "+" side, and when the knife groove width on the left side is larger, perform compensation to "-" side. <p>(Caution) When the needle rocking origin is improper, there is the possibility that right and left knife groove widths change each other or the presser interferes with needle ⑤ when the needle rocking width is increased.</p> <p>1) Needle rocking motor origin compensation</p> <ol style="list-style-type: none"> Press MODE key ④ M for approximately three seconds to enter memory switch level 2 of the adjustment mode. Select K16 with ITEM SELECTION key ⑩ ▲ ▼. When the existing set value is changed with DATA CHANGE key ⑪ + -, origin retrieval is performed and every time the set value is changed, needle moves to the position of the set value. Set value can be set within the range of -10 to 10. (0.05mm/1 pulse) Every time STOP button is pressed during setting the origin compensation value, the move from the position of existing compensation value to that of compensation value "0" is repeated. When the setting item of K16 is changed with ITEM SELECTION key ⑩ ▲ ▼, the origin compensation value is memorized in EEPROM of the machine head and the needle rocking motor origin compensation is completed. 	

(2) Adjusting the feed origin

Standard Adjustment

General drawing of feed mechanism

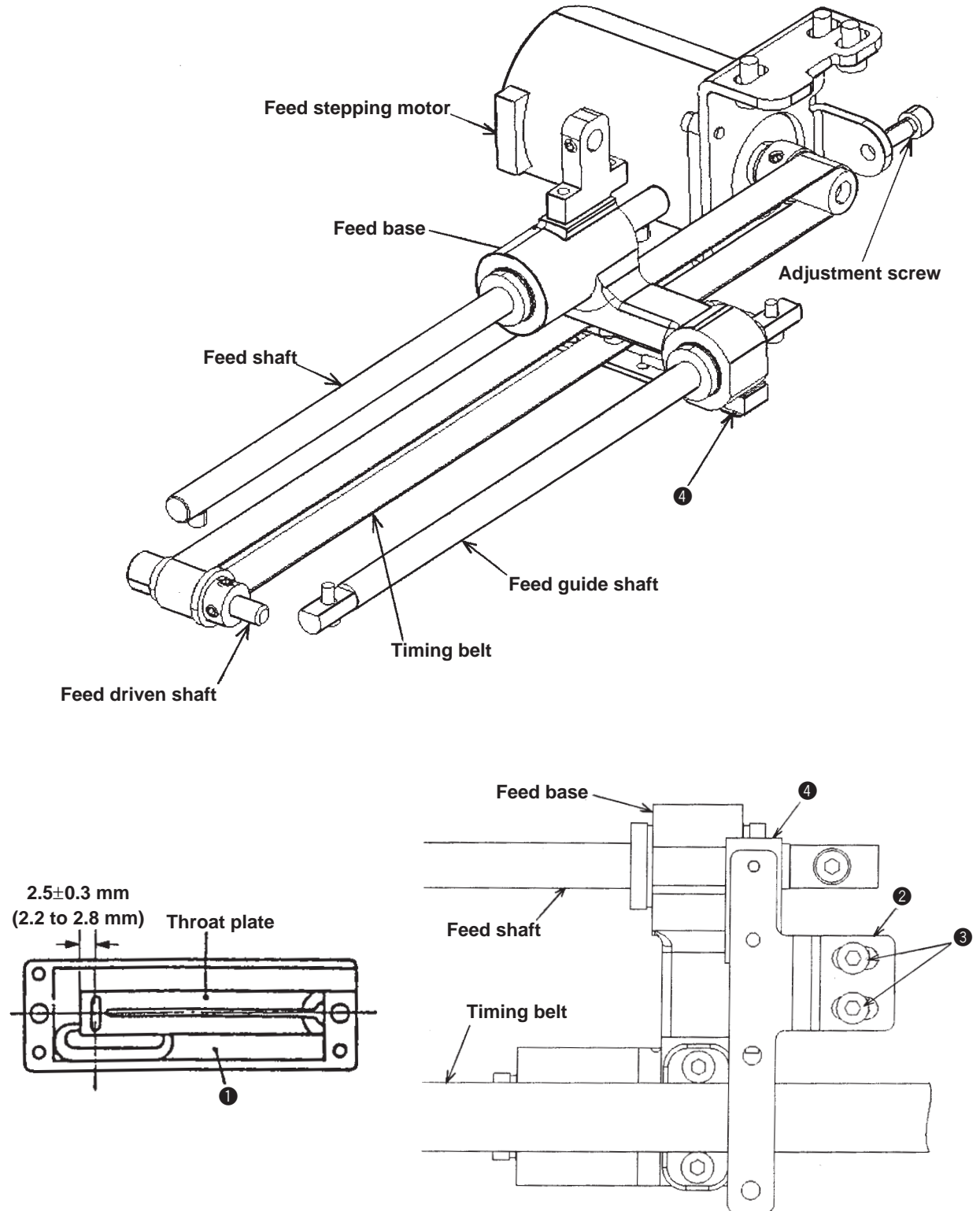

Adjustment Procedures	Results of Improper Adjustment
<p>(2) Adjusting the feed origin</p> <ol style="list-style-type: none"> Origin of lengthwise feed motor can be adjusted with memory switch level 2 K15. Move the feed with + or - key and adjust so that the distance from presser 1 to the center of the needle is 2.5 ± 0.3 mm. Loosen setscrews 3 in sensor installing plate 2, move feed sensor 4 and fix setscrews 3 at the position where the detecting lamp (built in the sensor) is changed over from ON to OFF. Return the compensation value to "0" and make the origin retrieval. Then check again the position of 2.5 ± 0.3 mm. (Origin retrieval is performed with the temporary stop switch located on the side of face plate section.) <p>(Caution) When the position of feed origin is improper, presser 1 interferes with needle when sewing the overlapped section. As a result, thread breakage or needle breakage will be caused.</p> <p>1) Feed motor origin compensation</p> <ol style="list-style-type: none"> Press MODE key 4 M for approximately three seconds to enter memory switch level 2 of the adjustment mode. Select K15 with ITEM SELECTION key 10 ▲ ▼. When the existing set value is changed with DATA CHANGE key 11 + -, origin retrieval is performed and every time the set value is changed, the feed moves to the position of the set value. Set value can be set within the range of -120 to 400. (0.025 mm/1 pulse) Every time STOP button is pressed during setting the origin compensation value, the move from the position of the existing compensation value to that of compensation value "0" is repeated. When the setting item of K15 is changed with ITEM SELECTION key 10 ▲ ▼, the origin compensation value is memorized in EEPROM of the machine head and the feed motor origin compensation is completed. 	<ul style="list-style-type: none"> Improper position of presser (improper longitudinal position of presser arm as well) influences closing/opening of the needle thread trimmer. In case the distance from the needle hole to the presser is excessively small when the feed origin is detected, the presser comes in contact with needle when sewing the overlapped section. As a result, thread breakage or needle breakage will be caused.

5. DISASSEMBLING/ASSEMBLING PROCEDURE

(1) Disassembling/assembling the main shaft

Procedures of disassembling/assembling

General drawing of the main shaft

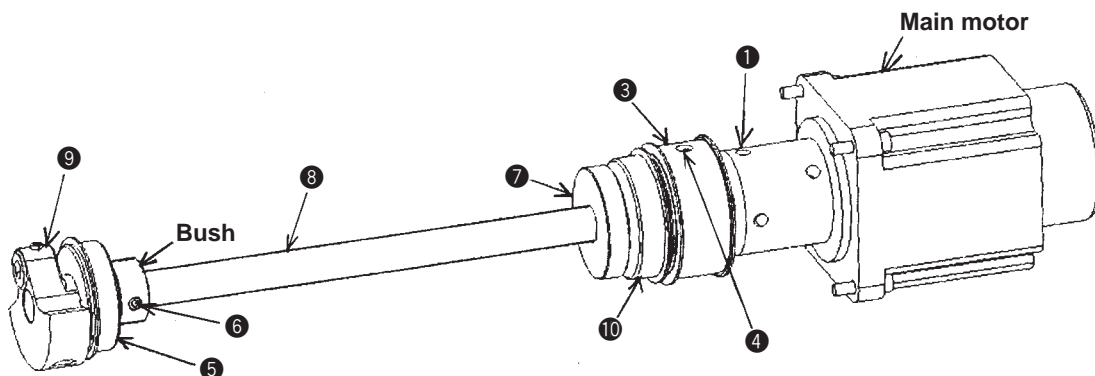
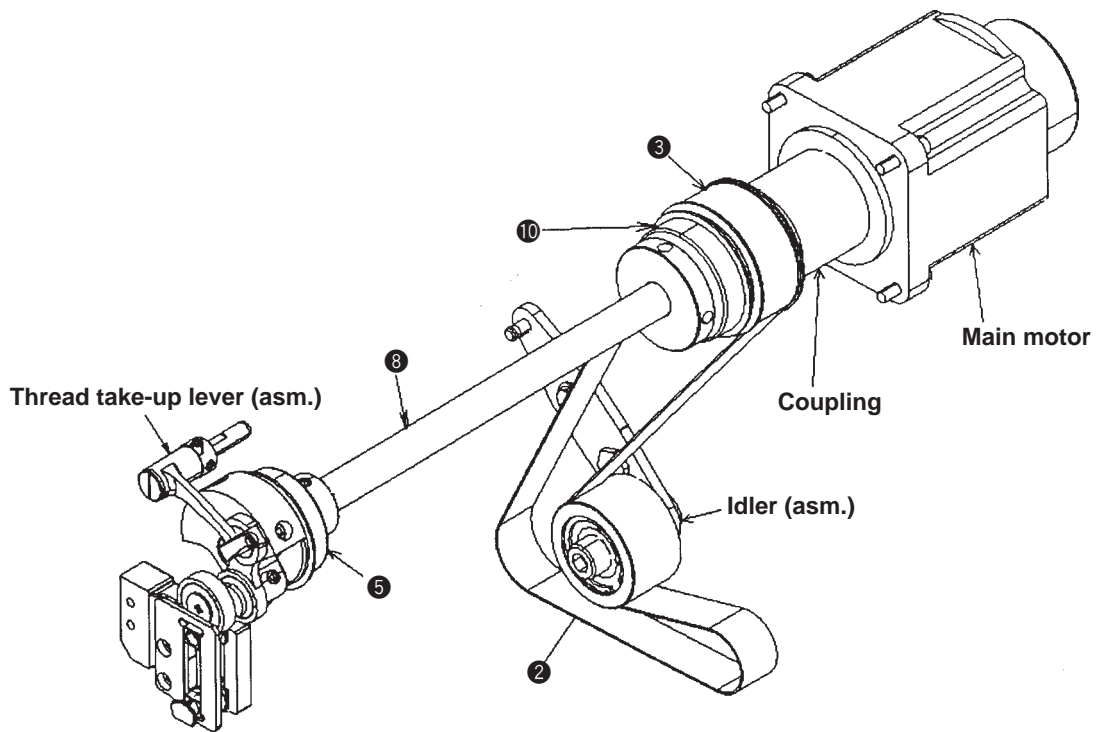

Procedures of disassembling/assembling

1. Removing the main shaft

- 1) Remove the face plate section referring to “(5) Disassembling/assembling the face plate section”.
- 2) Loosen two coupling setscrews ①. (LOCKTITE is applied to setscrews ①.)
- 3) Loosen timing belt ②, remove timing belt ② from main shaft sprocket ③ and loosen two main shaft sprocket setscrews ④.
- 4) Loosen two bush setscrews ⑥ in main shaft front bearing ⑤.
- 5) Loosen two setscrews in bobbin winder driving wheel ⑦ and draw forward main shaft ⑧ together with counter weight ⑨.

2. Assembling the main shaft

- 1) Insert counter weight ⑨ and main shaft ⑧ into the section of main shaft front bearing ⑤ and main shaft intermediate bearing ⑩.
- 2) Lightly press counter weight ⑨ from the front to the rear and fix two bush setscrews ⑥ in main shaft front bearing ⑤.
(Adjust so that screw No. 1 is set to the flat section of main shaft ⑧.)
- 3) Lightly press forward the main shaft sprocket and fix two setscrews ④ in main shaft sprocket ③.
(Adjust so that screw No. 1 is set to the flat section of main shaft ⑧.)
- 4) Fix two coupling setscrews ①.
(Adjust so that screw No. 1 is set to the flat section of main shaft ⑧.)
- 5) Adjust the position of bobbin winder driving wheel ⑦ and fix it with two setscrews.

(2) Replacing the timing belt (main shaft)

Procedures of disassembling/assembling

General drawing of the main shaft

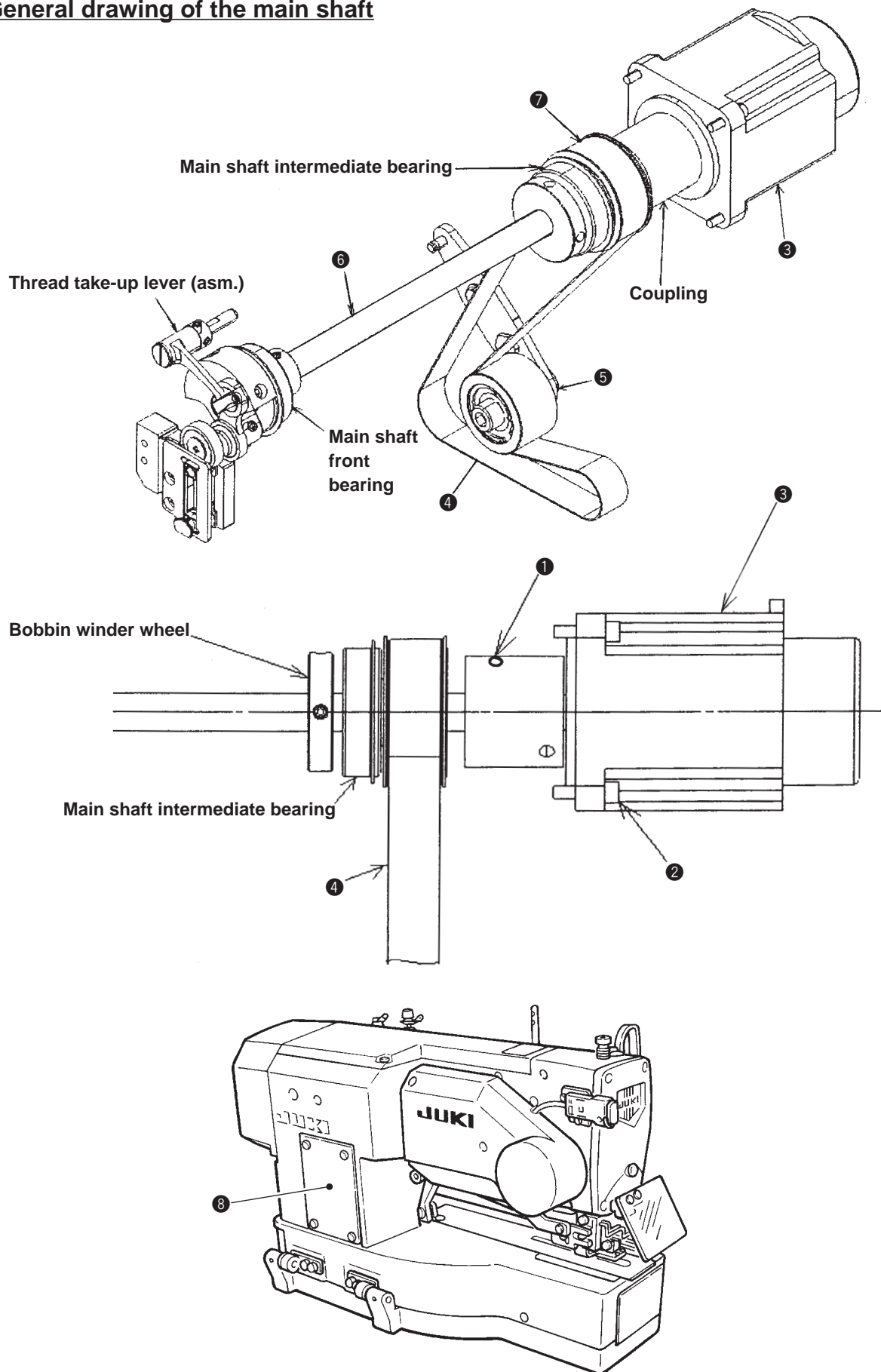

Procedures of disassembling/assembling

1. Removing the timing belt

- 1) Loosen two coupling setscrews ①. (LOCKTITE is applied to setscrews ①.)
- 2) Loosen four main motor installing screws ② and remove main motor ③. (When main motor ③ interferes with the presser lifter motor and it is difficult to remove it, loosen four setscrews in the presser lifter motor and slightly move the presser lifting motor to the side.)
- 3) Remove left side cover B ⑧, adjust the idler and loosen timing belt ④. (For the adjusting procedure of the idler, refer to "5.- (4) Adjusting the timing belt of main shaft and hook driving shaft (idler)".

2. Assembling the timing belt

- 1) Be careful of the position of idler section ⑤ and put sprocket ⑦ of main shaft ⑥ so that timing belt ④ is set to the proper position.
- 2) Assemble main motor ③ to the machine head and fix two setscrews ① of coupling. (Be sure to assemble it so that screw No. 1 is set to the flat section of main shaft.) Apply LOCKTITE 242 to the screws after removing oil from them.)
- 3) Adjust the idler and fix timing belt ④ with the proper belt tension. Refer to "5.- (4) Adjusting the timing belt of main shaft and hook driving shaft (idler)"

(Caution) When assembling timing belt ④, be sure to turn the sewing machine several times by hand and check that timing belt ④ is not put on one side.

(3) Replacing the timing belt (hook driving shaft)

Procedures of disassembling/assembling

General drawing of the hook driving shaft

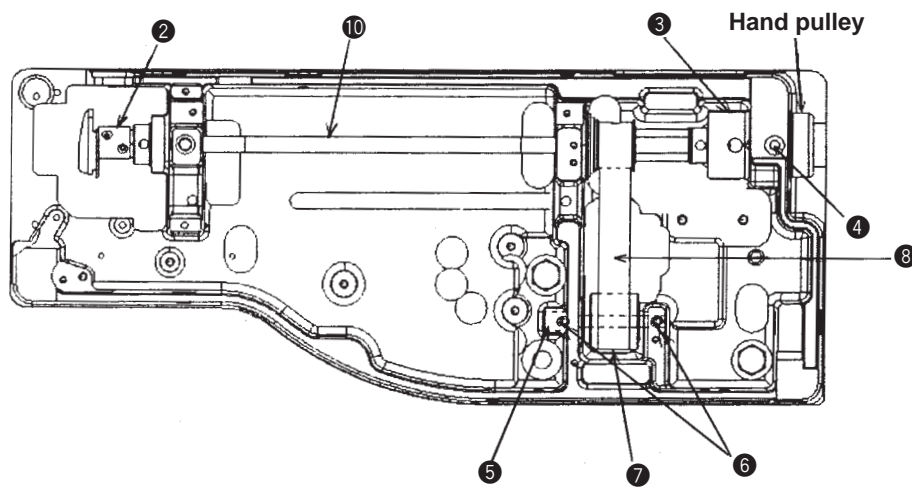
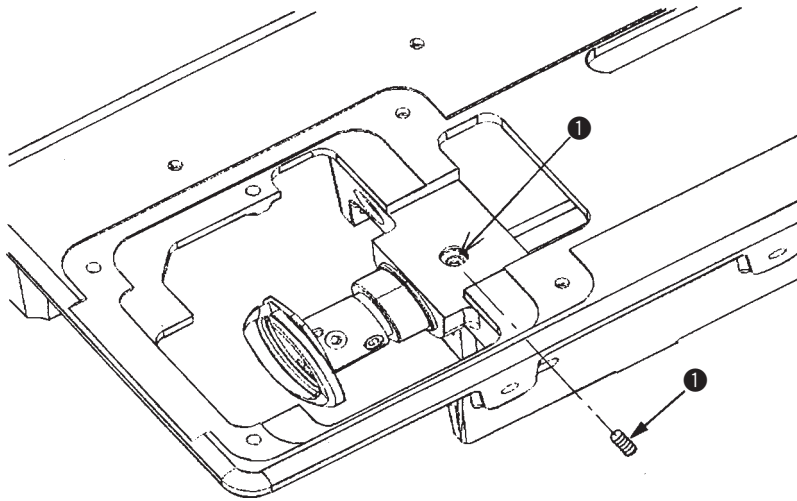
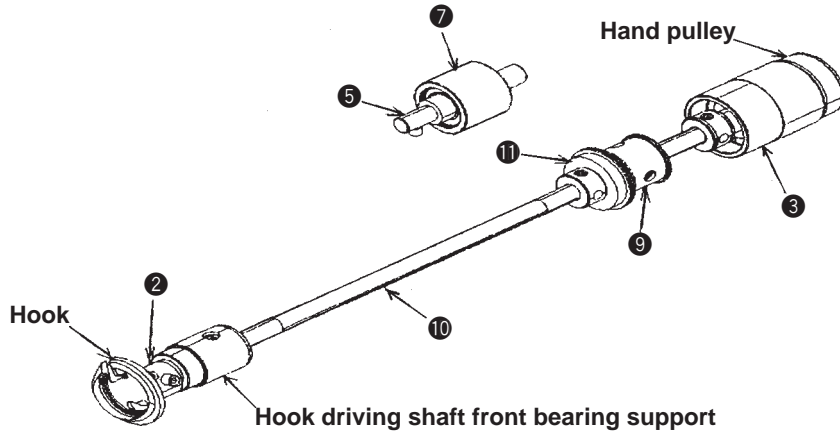

Hook driving shaft unit

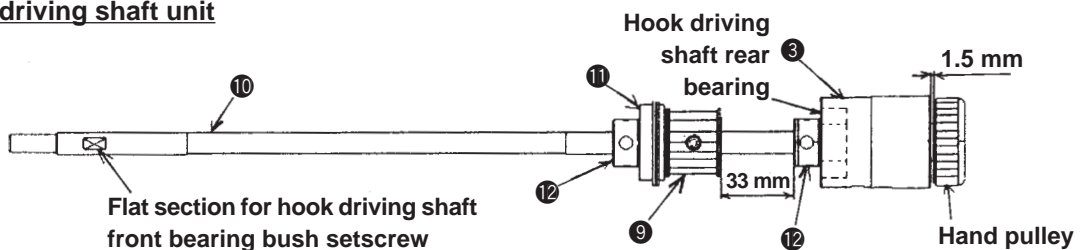

* Disassembling/assembling is possible in this state.

Procedures of disassembling/assembling

1. Removing the timing belt

- 1) Remove the feed plate and the throat plate connection and loosen two setscrews ① in the hook driving shaft bearing bush.
- 2) Tilt the machine head to the side and remove hook sleeve ②.
- 3) Loosen setscrew ④ in hook driving shaft bearing support ③ and draw backward the hook driving shaft unit.
- 4) Loosen two setscrews ⑥ in intermediate sprocket shaft ⑤ and draw backward intermediate sprocket shaft ⑤.
- 5) Draw out timing belt ⑧ from intermediate sprocket ⑦.

2. Assembling the timing belt

- 1) Set timing belt ⑧ to intermediate sprocket ⑦ and fix intermediate sprocket ⑦ with two screws.
- 2) Insert the hook driving shaft to the machine bed and assemble so that timing belt ⑧ is put on hook driving shaft sprocket ⑨. (Be careful that timing belt ⑧ is not damaged.)
- 3) Slightly close the bearing play so that there is no longitudinal play at hook driving shaft ⑩ and fix setscrew ④ in hook driving shaft bearing support ③. (Press the hook driving shaft unit to the front side and lightly press hook driving shaft bearing support ③ to the front side in the state that the flange section of hook driving shaft intermediate bearing ⑪ comes in contact with the machined plane of the machine bed.)
- 4) Raise the machine head and fix two setscrews in hook driving shaft bearing bush ⑫. (There is one flat section on hook driving shaft ⑩. Fix screw No. 1 to the flat section.)

(Caution)

1. **When assembling timing belt ⑧, be sure to turn the sewing machine several times by hand and check that timing belt ⑧ is not put on one side.)**
2. **If two setscrews ① in the hook driving shaft front bearing bush and setscrew ④ in hook driving shaft bearing support ③ are loosened, the hook vibrates and thread breakage or stitch skipping will be caused.**

(4) Adjusting the timing belt of main shaft (idler)

Standard Adjustment

Adjust so that the tension of timing belt of main shaft is 100 to 120N.

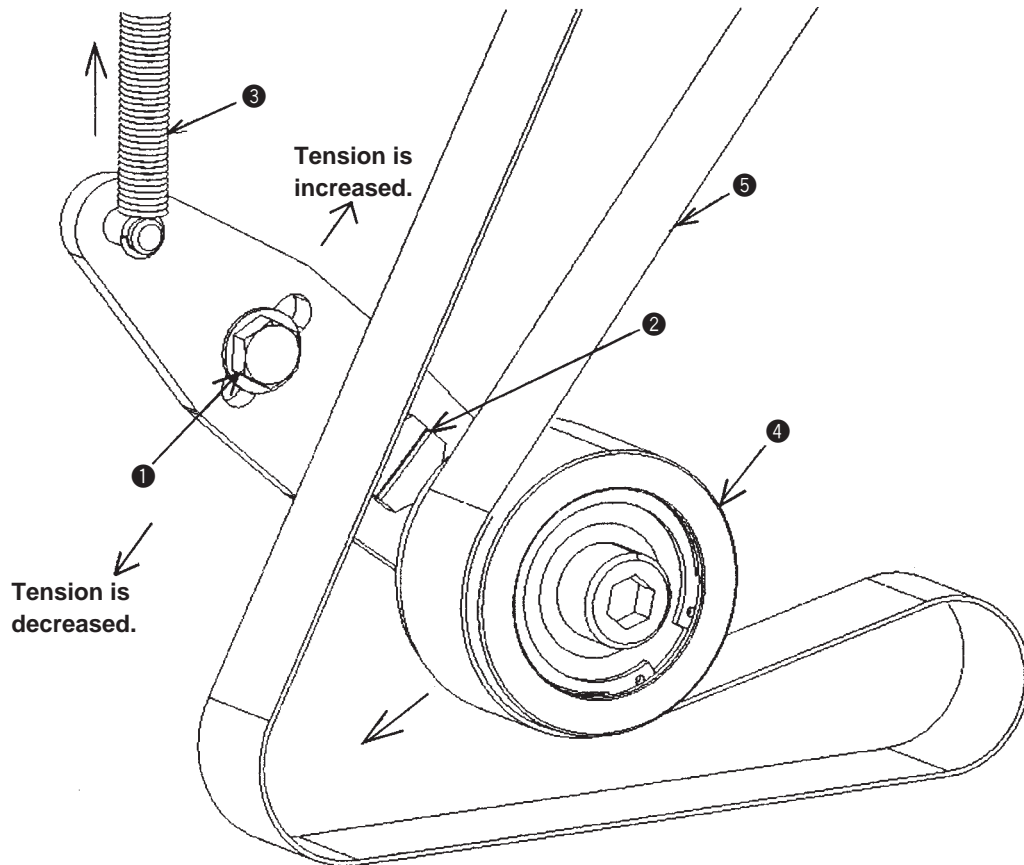

Adjustment Procedures	Results of Improper Adjustment
<p>1. Lightly loosen idler fixing screw ❶ and idler fulcrum hinge screw ❷, and tighten idler fixing screw ❶ in the state that idler ❹ is placed to timing belt ❺ by pressing with tension spring ❸. Then fix idler fulcrum hinge screw ❷.</p> <p>(When idler ❹ is placed by pressing with tension spring ❸, 100 to 120N is obtained. The tension of timing belt can be stabilized by lightly pressing and slowly setting free timing belt ❺ in the state that idler fixing screw ❶ in idler ❹ and idler fulcrum hinge screw ❷ are lightly loosened.</p> <p>(Caution) When the screws are excessively loosened, tilt of idler ❹ occurs and the assembling may be performed in the improper state. Or, when turning the main shaft several times by hand, timing belt ❺ may be put on one side. So, be very careful.</p>	

(5) Disassembling/assembling the face plate section

Procedures of disassembling/assembling

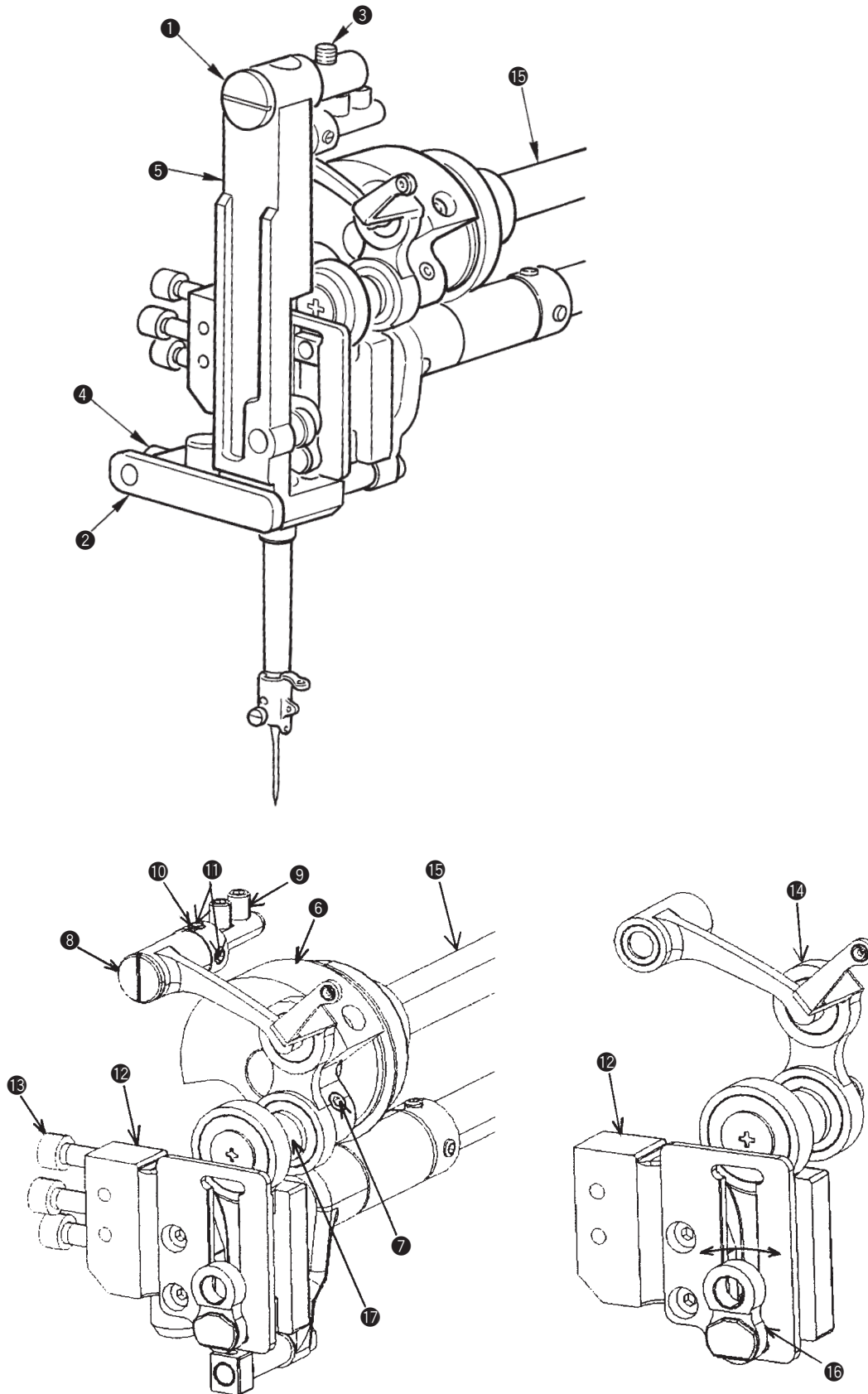

* Figure when removing as a set.

Procedures of disassembling/assembling

1. Disassembling the face plate section

- 1) Remove the face plate and the needle.
- 2) Loosen setscrews ③ and ④ in needle bar rocking frame fulcrum shaft ① and rocking frame support shaft ② and remove needle bar rocking frame ⑤.
(Remove the needle bar and needle bar bracket together with needle bar rocking frame ⑤.)
- 3) Loosen two fixing screws ⑦ in the thread take-up lever attached to counter weight ⑥.
- 4) Loosen two setscrews ⑨ in thread take-up crank shaft ⑧ and two setscrews ⑪ in thrust collar ⑩, and remove thread take-up crank shaft ⑧.
- 5) Remove three setscrews ⑬ in square block base ⑫ and remove thread take-up lever (total asm ⑭.) and square block base ⑫ as a set.

2. Assembling the face plate section

- 1) Set the set of square block base ⑫ and thread take-up lever (total asm ⑭.) to counter weight ⑥.
- 2) Fix the flat section of needle bar crank ⑰ of thread take-up lever (total asm ⑭.) so that it is set to screw No. 2 side of fixing screws ⑦ attached to counter weight ⑥. Fix screw No. 1 side as well.
(The proper needle stroke cannot be obtained if screws No. 1 and No. 2 are attached in reverse order.)
- 3) Put thrust collar ⑩ and temporarily put thread take-up crank shaft ⑧ in the machine head.
- 4) Temporarily tighten setscrew ⑬ in square block base ⑫, turn main shaft ⑮ by hand, and fix setscrew ⑬ in square block base at the position where link ⑯ can smoothly rock without uneven torque.
(Lightly put your hand on the upper hole section of link ⑯, turn the sewing machine and rock the link to the right and left to check the motion.)
- 5) Fix thrust collar ⑩ so that there is no longitudinal play of the thread take-up lever support.
(There is one flat section for thrust collar setscrew on thread take-up crank shaft ⑧.)
- 6) Fix thread take-up crank shaft ⑧ to the machine head at the position where main shaft ⑮ is turned several times and it is stabilized.
(Fixing of thread take-up crank shaft ⑧ is performed at two places and the flat section is on the front side.)
- 7) Set needle bar rocking frame ⑤.
(Insert it while being careful of the square block and the shaft section of needle bar bracket.)
- 8) Fix needle bar rocking frame fulcrum shaft ① and needle bar rocking frame support shaft ② so that the thrust play does not occur at needle bar rocking frame ⑤. (Rock needle bar rocking frame ⑤ to the right and left after closing the play and check that the rocking is not heavy.)

(Caution) Be sure to perform the break-in operation for nearly one hour when performing re-arranging the face plate section, and check there is no noise or uneven rotation.

(6) Disassembling/assembling the needle rocking motor

Procedures of disassembling/assembling

Needle rocking mechanism drawing

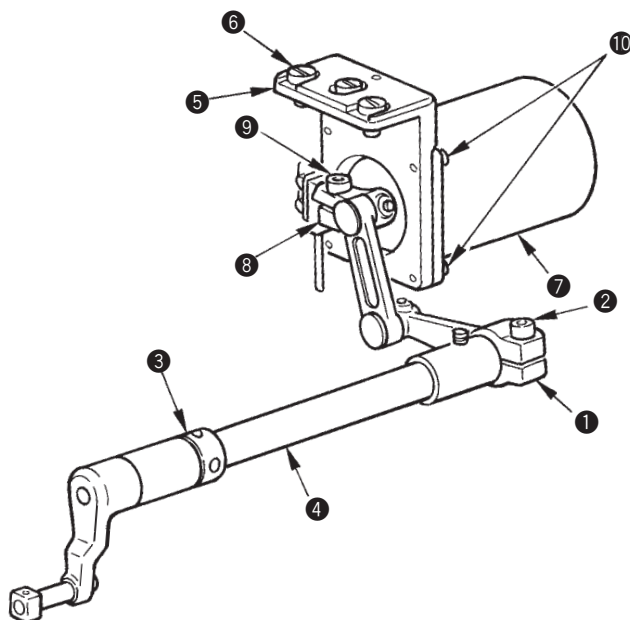
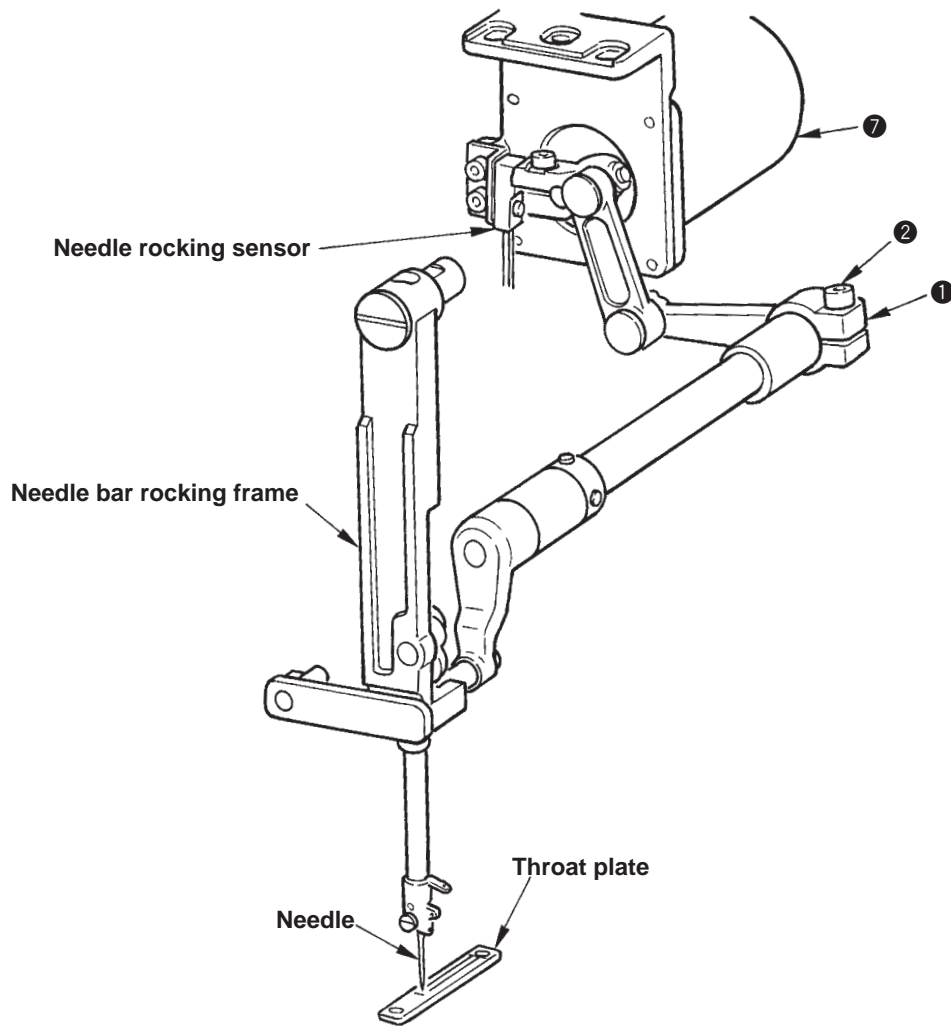

Needle rocking motor unit

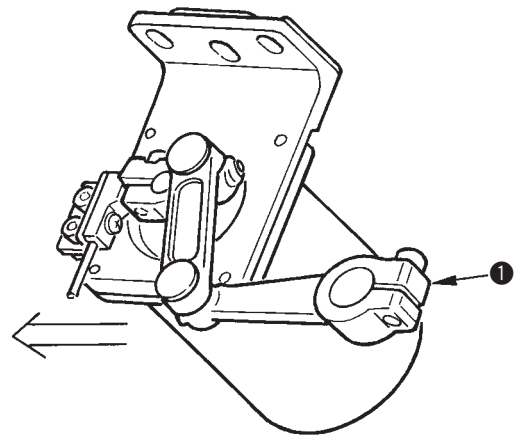

Procedures of disassembling/assembling

1. Removing the needle rocking motor

- 1) Remove the face plate section. (Refer to 5.- (5)) Disassembling/assembling the face plate section.)
- 2) Loosen setscrew ② in needle bar rocking lever, rear ①.
- 3) Loosen two setscrews in thrust collar ③.
- 4) Draw out forward needle bar rocking shaft ④.
- 5) Remove three setscrews ⑥ in needle rocking motor installing base ⑤.
- 6) Lift upward the motor together with needle rocking motor installing base ⑤.
- 7) Tilt downward the rear side of needle rocking motor ⑦, move the position of needle bar rocking lever, rear ① in the direction of arrow mark and lift it upward.
- 8) Loosen setscrew ⑨ in motor lever ⑧, remove four fixing screws ⑩ in the needle rocking motor and remove needle rocking motor ⑦.
- 9) Remove the motor cover and the rear cover, and draw out the wiring up to the relay p.c.b.

2. Assembling the needle rocking motor

- 1) Fix needle rocking motor ⑦ to needle rocking motor installing base ⑤.
- 2) Adjust motor lever ⑧ to the edge of the motor shaft and fix setscrew ⑨.
- 3) Set the needle rocking motor unit to the machine head.
- 4) Temporarily tighten needle rocking motor installing base ⑤ with three setscrews ⑥.
- 5) Insert needle bar rocking shaft ④ into the metal and fix it with thrust collar ③ at the position where it can smoothly rock without thrust play.

(Caution) When inserting needle bar rocking shaft ④, insert it into the hole in needle bar rocking lever, rear ① as well.

- 6) Rock needle bar rocking lever, rear ① by hand and fix three setscrews ⑥ in needle rocking installing base ⑤ at the position where there is no torque.
 - 7) Wire the cord of needle rocking motor ⑦ to the relay p.c.b.
 - 8) Perform the origin adjustment of the needle rocking. (Refer to "4.-(1) Adjusting the needle rocking origin".)
- * Even when replacing the needle rocking sensor, remove the needle rocking motor unit in accordance with the aforementioned description.

(7) Replacing the cloth cutting knife solenoid

Procedures of disassembling/assembling

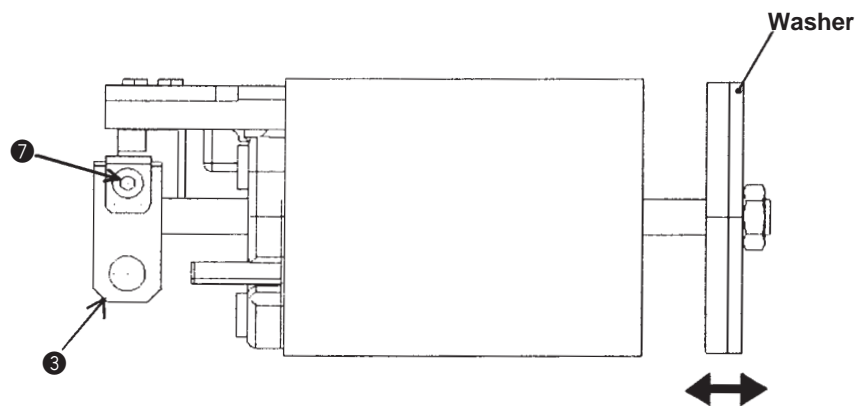
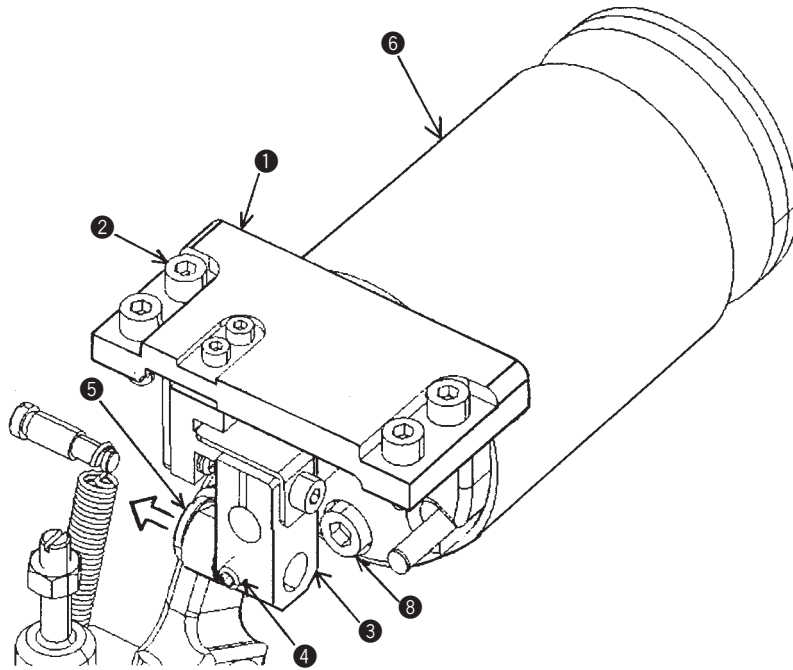

Cloth cutting knife solenoid single body

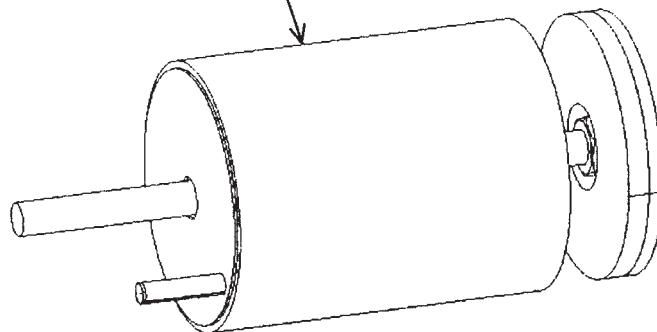

Procedures of disassembling/assembling

- 1) Remove the top plate cover.
- 2) Remove four setscrews ② in solenoid installing base ①.
- 3) Loosen setscrew ④ in knife holder ③ and draw out gib-headed shaft ⑤ in the direction of arrow mark.
- 4) Lift upward cloth cutting knife solenoid ⑥, loosen screw ⑦ in the knife holder section, and remove knife holder ③.
- 5) Loosen three screws ⑧ which are fixing solenoid installing base ① and cloth cutting knife solenoid ⑥.
- 6) Remove the motor cover and the rear cover, and draw out the wiring cord up to the relay p.c.b.

* **For the assembling procedure, perform it by reversing the aforementioned steps.**

* **After assembling, move the washer of cloth cutting knife solenoid ⑥ to and fro (direction of arrow mark) and check that it smoothly moves.**

(8) Replacing the cloth cutting knife solenoid cushion

Procedures of disassembling/assembling

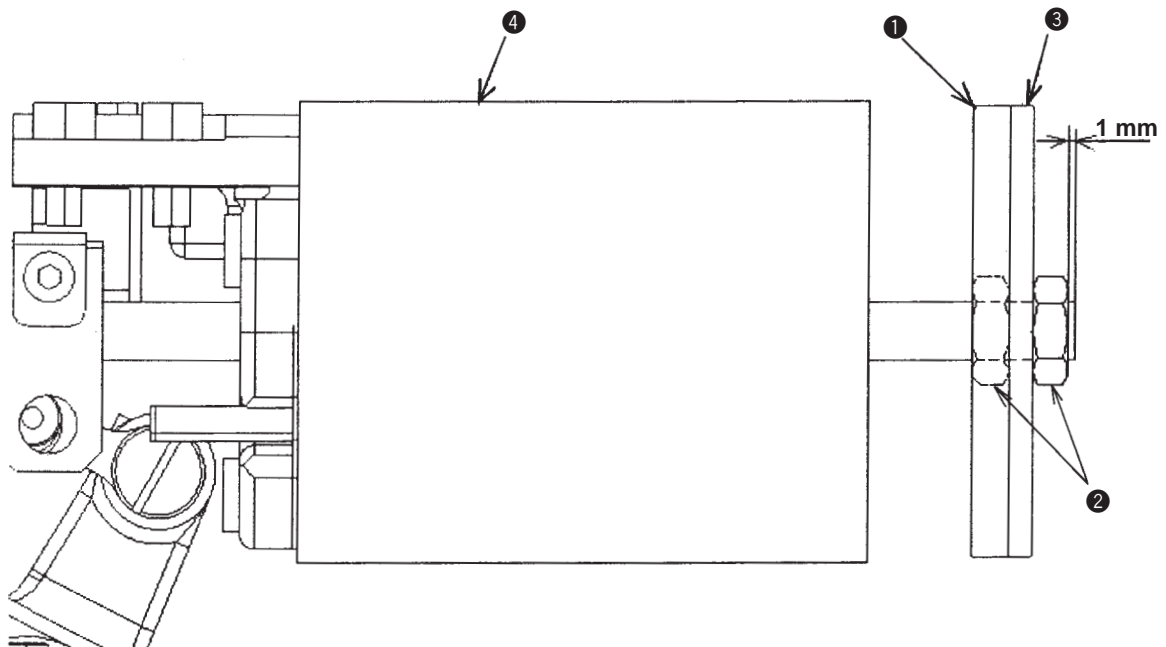
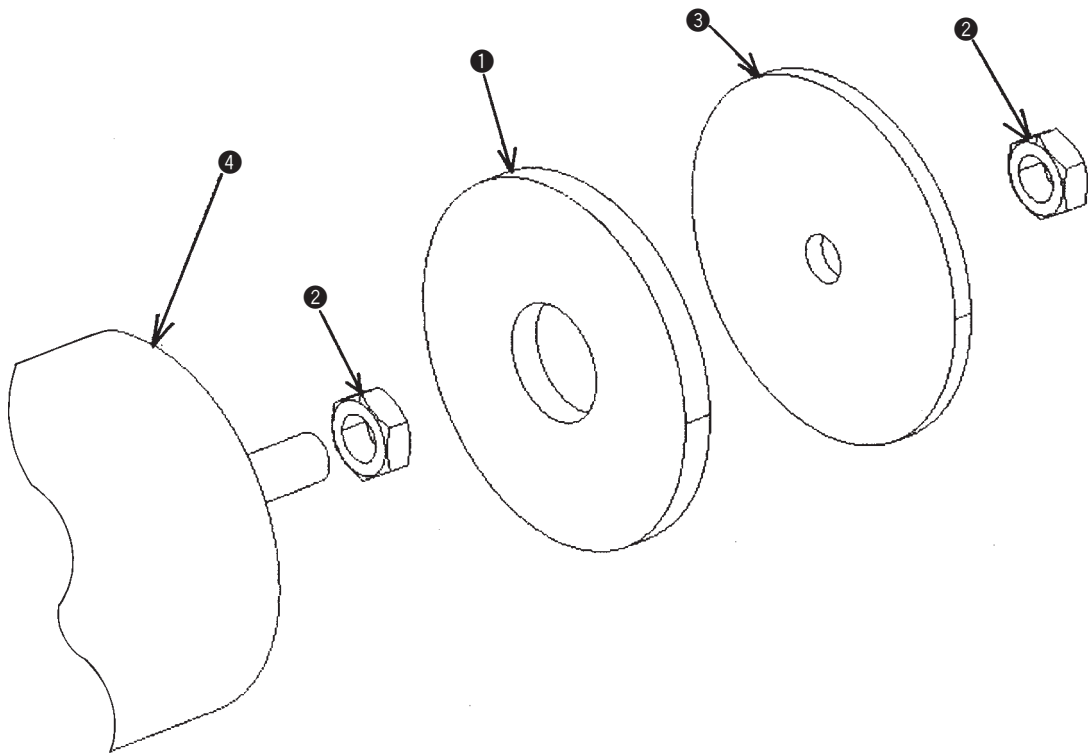

Procedures of disassembling/assembling

- 1) Loosen with the spanner two nuts ② assembled to the front and rear of cushion ①.
- 2) Cushion ① is pasted to washer ③ with the both-side adhesive tape. Strip off the tape and wipe off neatly the plane of washer ③.
- 3) Paste new cushion ① (with both-side adhesive tape) to washer ③ and fix two nuts ② so that nut ② comes to the place of 1 mm from the end of cloth cutting knife solenoid shaft.

(9) Replacing the knife return stopper

Procedures of disassembling/assembling

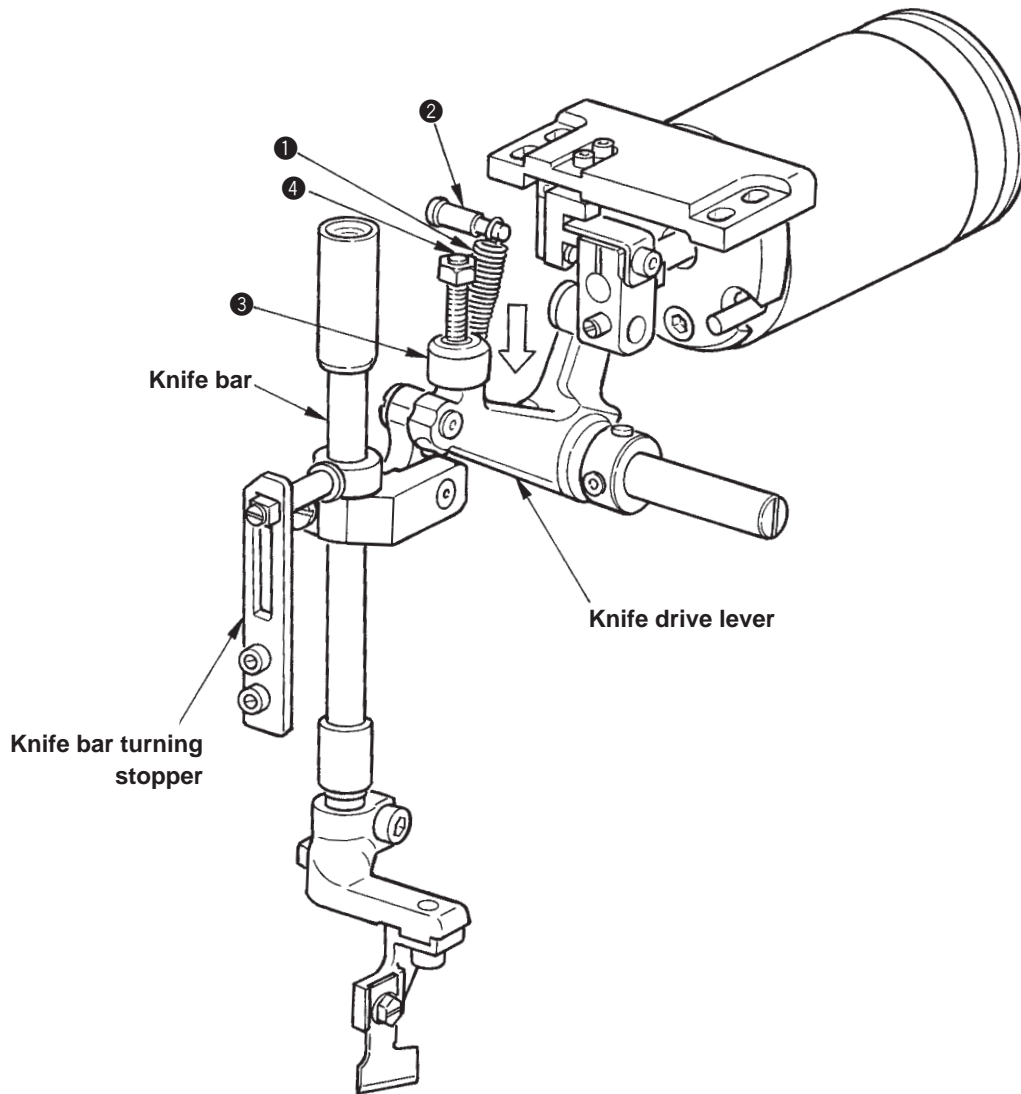

Procedures of disassembling/assembling

- 1) Remove knife return spring ❶ from spring bracket ❷.
- 2) Loosen and remove nut ❸ of knife return stopper ❹.
- 3) Screw in knife return stopper ❹ to the lower side and draw it out.

*** For the assembling procedure, perform it by reversing the aforementioned steps.
(For the position of the stopper, refer to 3.-(5) Adjusting the stroke and the initial position of the cloth cutting knife.)**

6. LUBRICATION

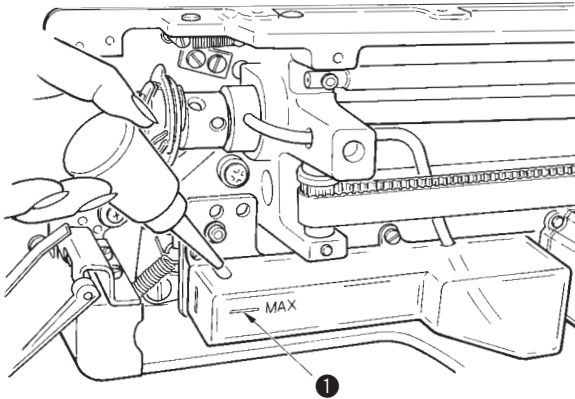

(1) Lubricating oil to oiling tank

1. Fill the oiling tank with New Defrix Oil No.1 up to the level indicated by "MAX" ❶.

(2) Adjusting the lubrication for the sewing hook

1. Adjust the amount of oil supplied to the sewing hook by loosening lock nut ❷ and turning oil amount adjusting screw ❸.
2. Amount of supplied oil is decreased when turning screw ❸ clockwise.
3. After adjusting the amount of oil, fix the screw with lock nut ❷.
4. When you first operate your sewing machine after set-up or after an extended period of disuse, remove the bobbin case and apply a few drops of oil to the hook race.

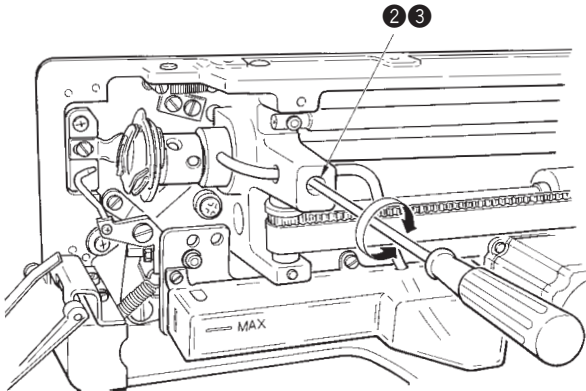

Detailed diagram of oil amount adjusting section

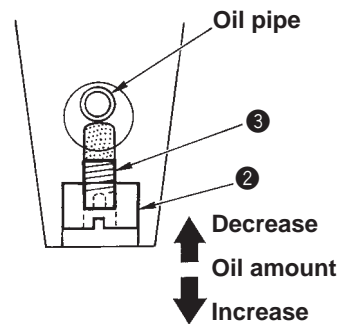

(3) Applying grease

Section A :  : JUKI exclusive grease (face plate section)

Section B :  : ESSO TEMPLEX (other than face plate section)

1) Main shaft components

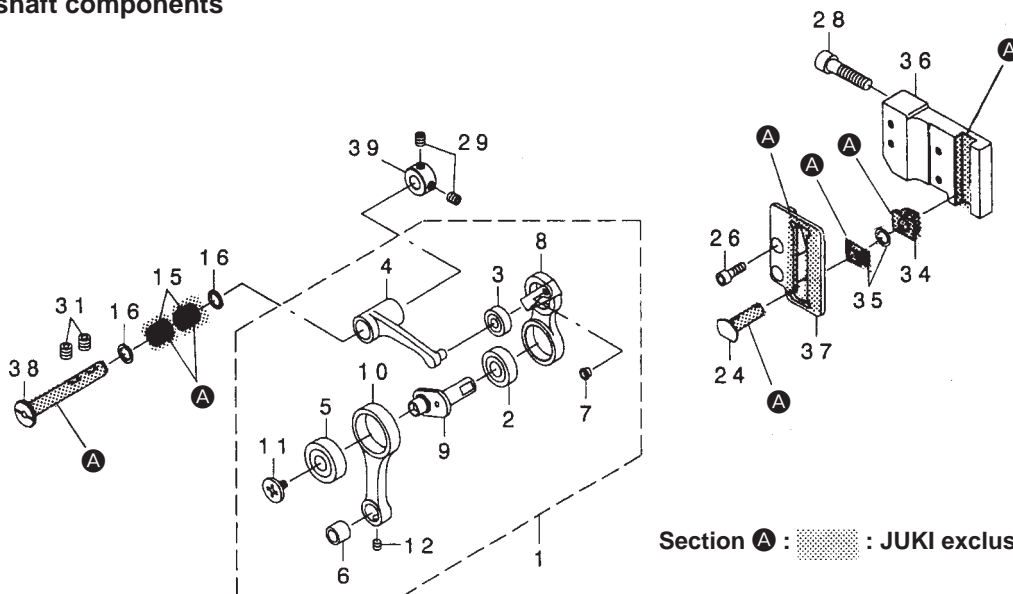

Section A :  : JUKI exclusive grease

2) Presser and feed components

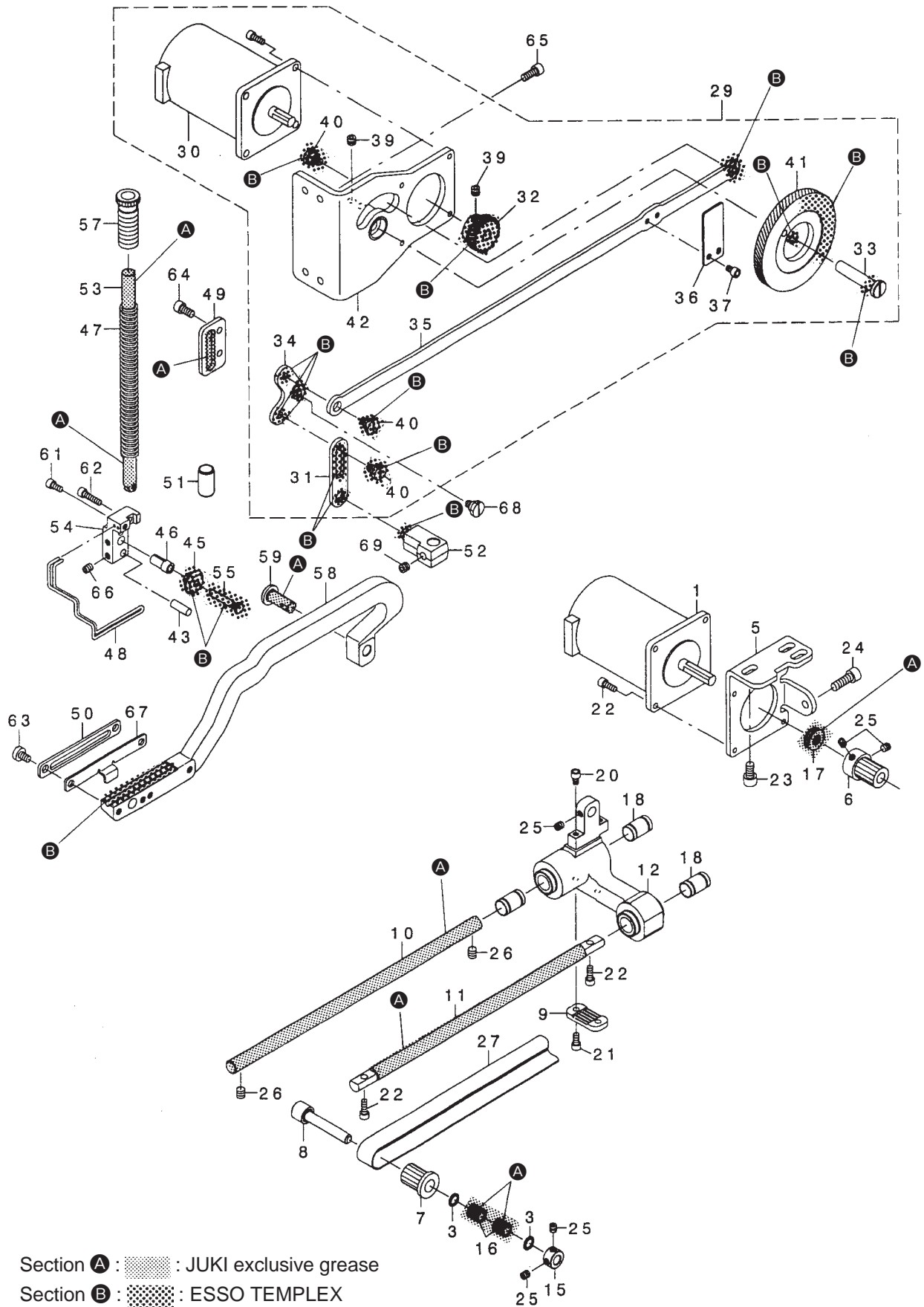

3) Needle bar rocking components

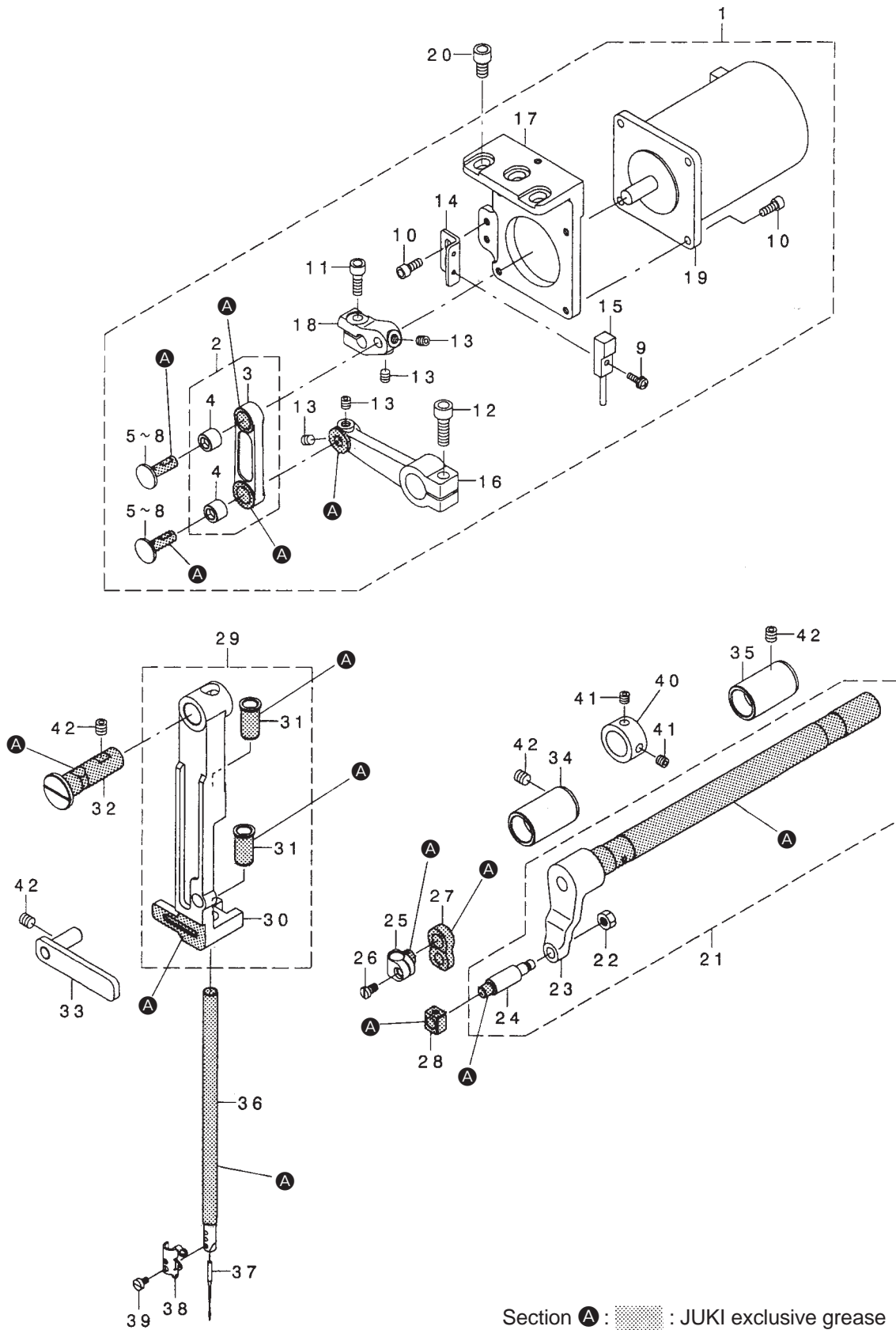

4) Needle thread trimmer components

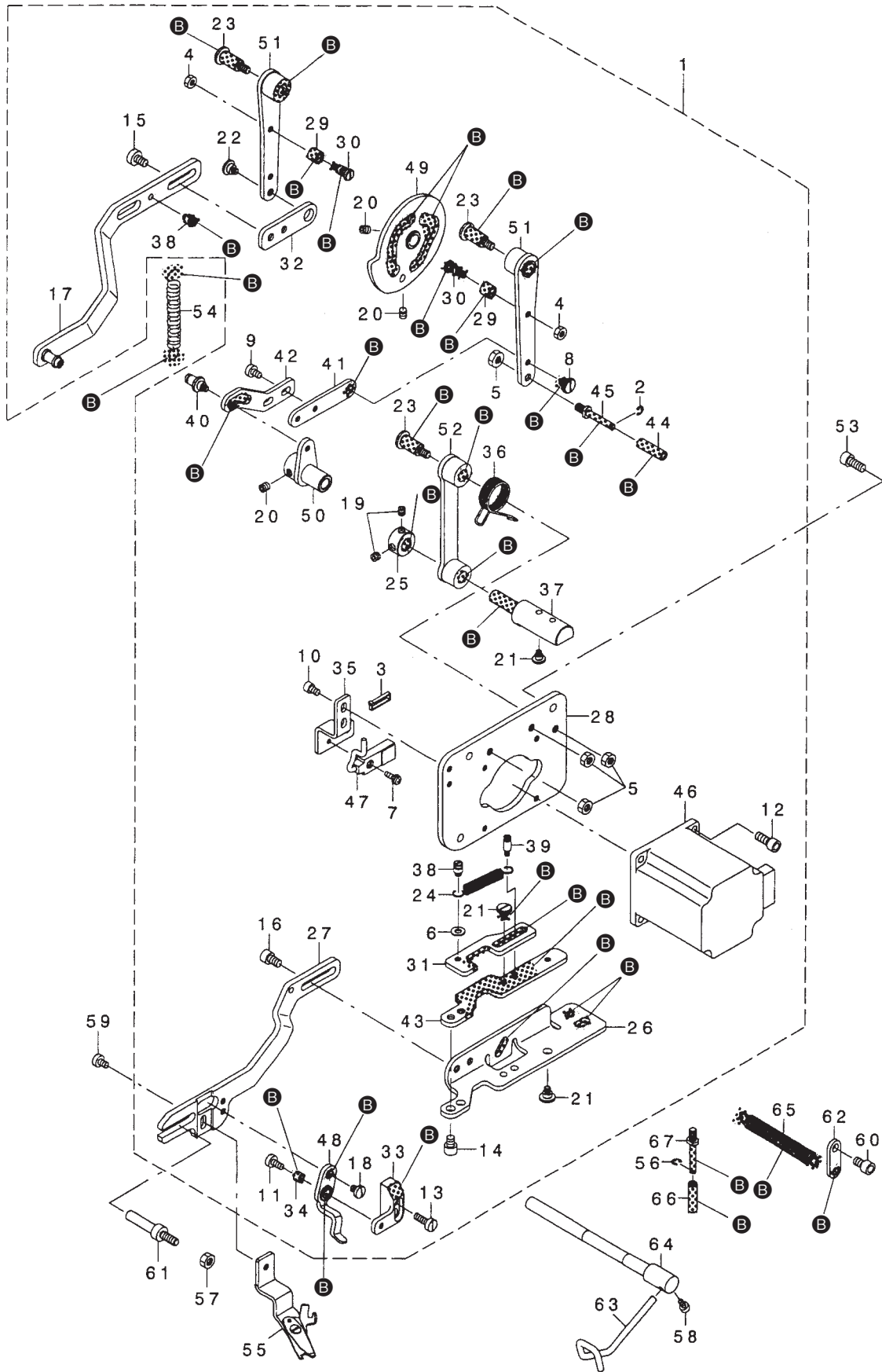

Section **B** :  : ESO TEMPLEX

5) Cloth cutting knife components

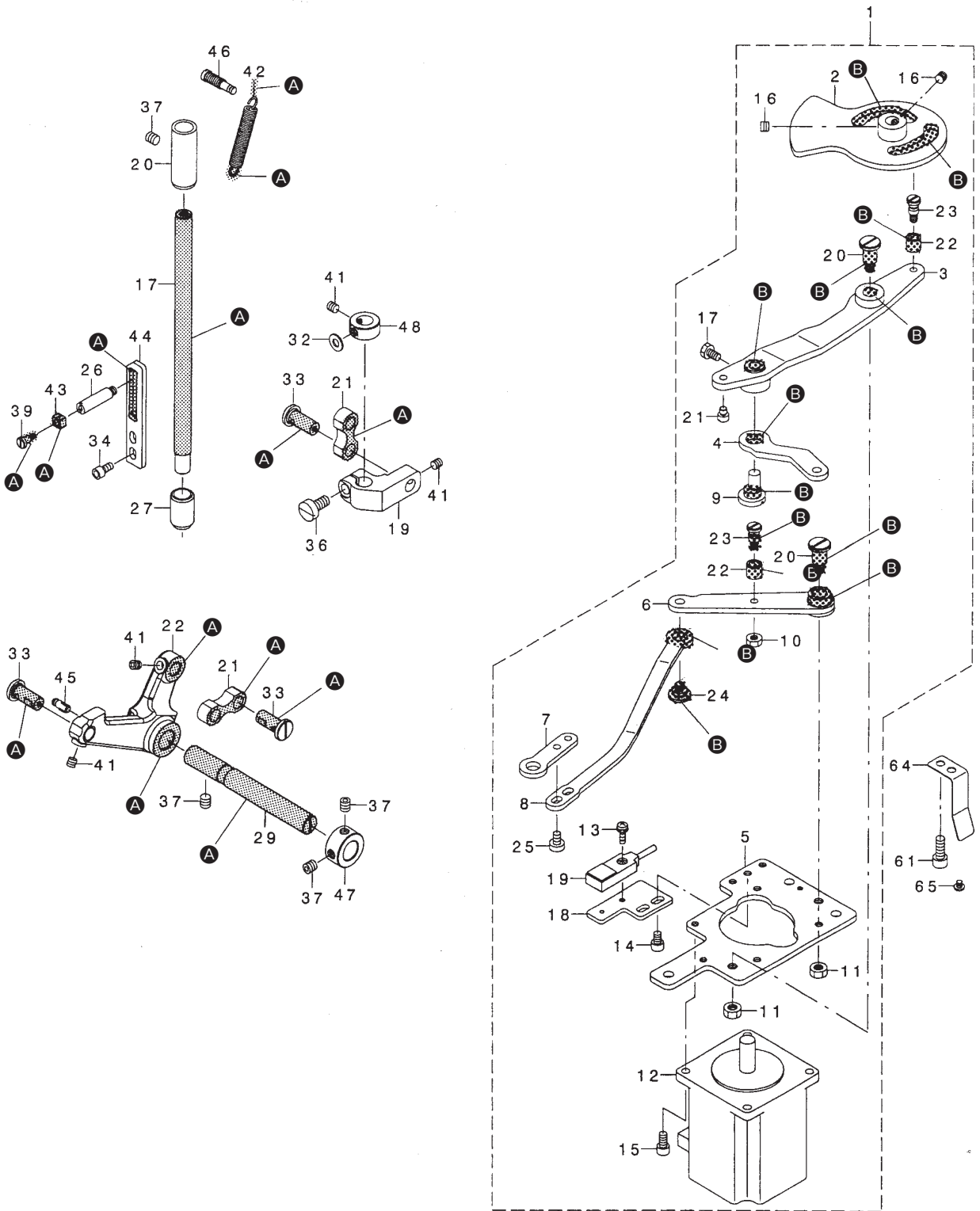

Section **A** :  : JUKI exclusive grease
 Section **B** :  : ESSO TEMPLEX

A blank sheet of lined paper with rounded corners and horizontal ruling lines. The lines are evenly spaced and extend across the width of the page. The top and bottom corners are rounded.

7. OPERATION PANEL

(1) Structure of the operation panel

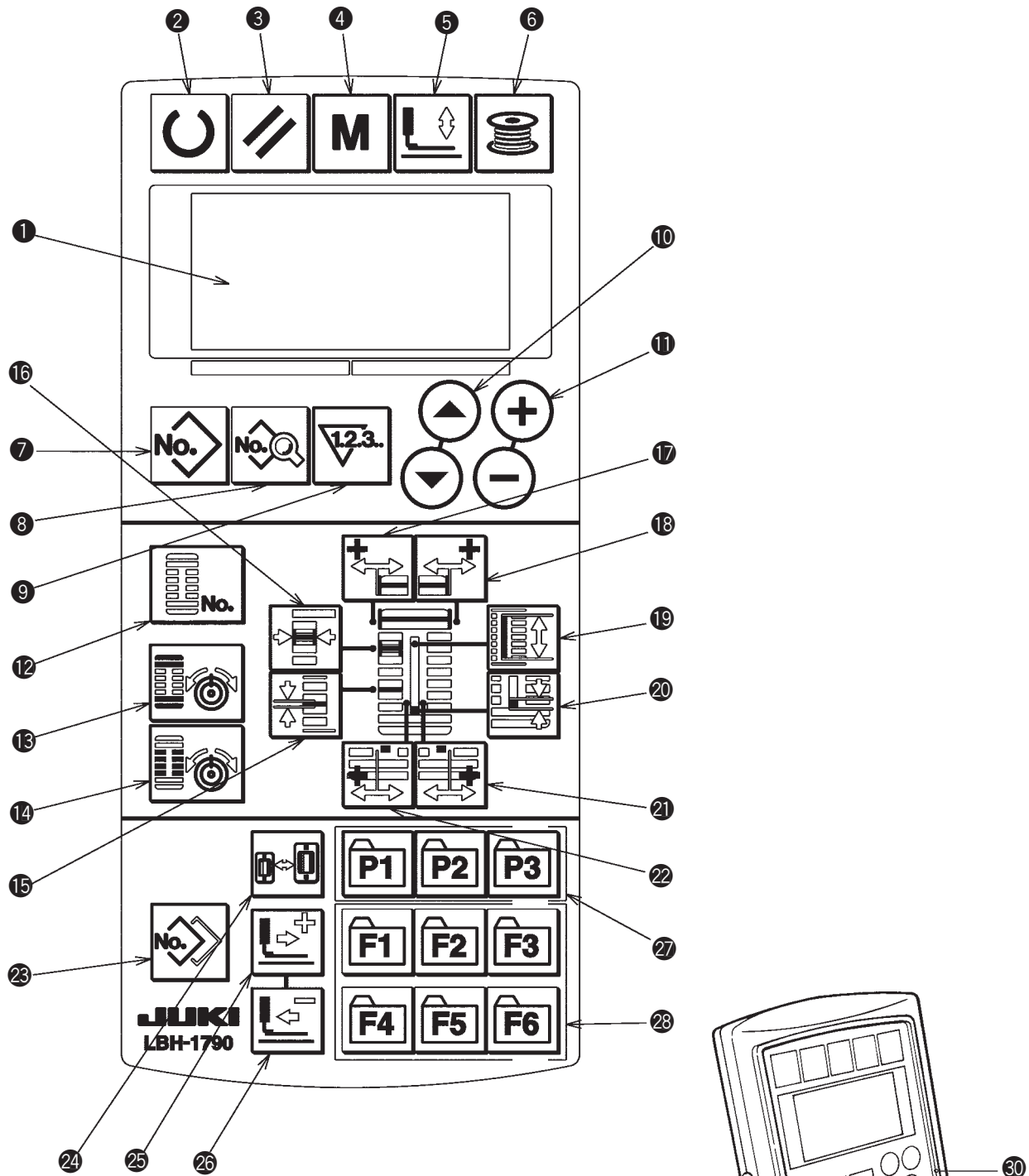

















There are 3 states below according to back-light colors.

Blue : Input mode Data change is possible.

Green : Sewing mode Sewing possible state

Yellow : Error state Some error occurs.











Operation panel function list

No.	NAME	FUNCTION	No.	NAME	FUNCTION
①	LCD display	Various data such as pattern No., shape, etc. are displayed.	⑬	OVEREDGING WIDTH key	This key selects overedging width display.
②	READY key 	Press this key when starting sewing. Every time this key is pressed, change-over of sewing ready set state and data set state can be performed.	⑭	BAR-TACKING WIDTH, LEFT key	This key selects left side of bar-tacking width compensation display.
③	RESET key 	Press this key when releasing error, travelling the feed mechanism to its initial position, counter resetting, etc.	⑮	BAR-TACKING WIDTH, RIGHT key	This key selects right side of bar-tacking width compensation display.
④	MODE key 	Press this key when changing data of the memory switches.	⑯	CLOTH CUT LENGTH key	This key selects cloth cut length display.
⑤	PRESSER key 	This key lifts or lowers the presser, and the needle bar travels to the right.	⑰	CLEARANCE key	This key selects clearance display.
⑥	WINDER key 	When this key is pressed, and the sewing machine enters the bobbin winding mode.	⑱	KNIFE GROOVE WIDTH, RIGHT key	This key selects knife groove width, right compensation display.
⑦	PATTERN NO. key 	This key selects pattern No. display.	⑲	KNIFE GROOVE WIDTH, LEFT key	This key selects knife groove width, left compensation display.
⑧	DATA key 	This key selects data display.	⑳	COPY key 	Press this key when copying pattern.
⑨	COUNTER key 	Thus key selects counter display.	㉑	PRESSER SELECTION key 	This key selects presser type.
⑩	ITEM SELECTION key 	This key selects pattern No., data No., etc.	㉒	FORWARD key 	This key makes the feed mechanism travel forward stitch by stitch.
⑪	DATA CHANGE key 	This key changes various data.	㉓	BACKWARD key 	This key makes the feed mechanism travel backward stitch by stitch.
⑫	SHAPE key 	This key selects shape display.	㉔	CUSTOMIZE key 	This is a short cut key that customizing is possible. Registration of short cut to setting display of an optional pattern is possible,
⑬	THREAD TENSION AT PARALLEL SECTION key 	This key selects thread tension at parallel section display.	㉕	CUSTOMIZE key 	This is a short cut key that customizing is possible. Registration of short cut to setting display of an optional pattern, sewing parameter or adjustment data is possible.
⑭	THREAD TENSION AT BAR-TACKING SECTION key 	This key selects thread tension at bar-tacking section display.	㉖	Speed variable resistor	Speed increases when this is lifted upward and decreases when this is lowered downward.
⑮	PITCH key 	This key selects pitch of parallel section.	㉗	LCD adjustment variable resistor	Light and shade of LCD display can be adjusted.

8. VARIOUS DATA LIST

(1) Sewing data list









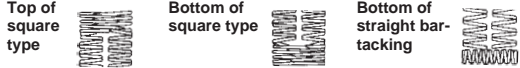

- ☆ Sewing data are those that can be inputted to 99 patterns from pattern 1 to 99 and can be inputted to each pattern. The sewing machine has been set in the state that the data which is necessary to set "With/without edit" cannot be selected at the time of your purchase. Change over the function to "With edit" if necessary for the use. → Refer to **12. Method of setting sewing data with/without edit (Instruction Manual)**.







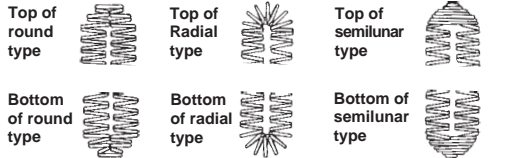

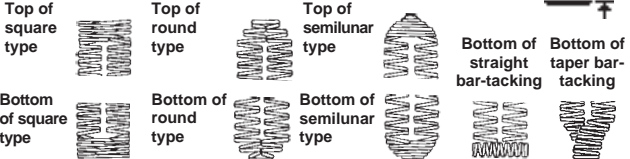







No.	Item	Setting range	Edit unit	Remarks
S01	<p>Sewing shape</p> <p>This item selects the shape from among the sewing shapes of 30 different kinds which the sewing machine has.</p>  <p>Refer to 2. Standard sewing shape list.</p> <p>* Only 12 kinds of standard sewing shapes can be selected at the time of your purchase. When increasing the kinds of shapes, perform setting of K04 Sewing shape selection level\$ of memory switch data. → Refer to 8.-(2) Memory switch list.</p>	1 to 30 (30 shapes)	1	–
S02	<p>Cloth cut length</p> <p>This item sets the length of cloth that is cut by cloth cutting knife. However, in case of bar-tack shape (Nos. 27, 28, 29, and 30 of S01), sewing length is set.</p>  <p>By making effective U19 Function of plural motions of cloth cutting knife of memory switch data, make the plural motions of knife by the knife size set in the item U18 Cloth cutting knife size, and the sewing product is cut. → Refer to 8.-(2) Memory switch list.</p>	3.0 to 120.0	0.1mm	–
S03	<p>Knife groove width, right</p> <p>This item sets the clearance between cloth cutting knife and right parallel section.</p> 	-2.00 to 2.00	0.05mm	–
S04	<p>Knife groove width, left</p> <p>This item sets the clearance between cloth cutting knife and left parallel section.</p> 	-2.00 to 2.00	0.05mm	–
S05	<p>Overedging width, left</p> <p>This item sets the overedging width of left parallel section.</p> 	0.10 to 5.00	0.05mm	–
S06	<p>Ratio of right and left shapes</p> <p>This item sets enlargement/reduction ratio of right side shape making the knife position as the center.</p> 	50 to 150	1%	–
S07	<p>Pitch at parallel section</p> <p>This item sets sewing pitch of left and right parallel sections.</p> 	0.200 to 2.500	0.025mm	–
S08	<p>2nd bar-tacking length</p> <p>This item sets length of bar-tacking on the front side.</p>  	0.2 to 5.0	0.1mm	–
S09	<p>1st bar-tacking length</p> <p>This item sets length of bar-tacking on the rear side.</p>  	0.2 to 5.0	0.1mm	–











* 1 : Displayed according to the shape











* 2 : Displayed when it is set to with edit. Refer to 12. Method of setting sewing data with/without edit (Instruction Manual).

* 3 : Displayed when the function is selected.

No.	Item	Setting range	Edit unit	Remarks
S10	Compensation of bar-tacking width, right This item adjusts right side outer shape of bar-tacking section in terms of overredging section. 	-1.00 to 1.00	0.05mm	—
S11	Compensation of bar-tacking width, left This item adjusts left side outer shape of bar-tacking section in terms of overredging section. 	-1.00 to 1.00	0.05mm	—
S12	Taper bar-tacking offset, left This item sets length to form bar-tacking section of taper bar-tacking shape. 	0.00 to 3.00	0.05mm	*1
S13	Taper bar-tacking offset, right This item sets length to form bar-tacking section of taper bar-tacking shape. 	0.00 to 3.00	0.05mm	*1
S14	Eyelet shape length This item sets upper side length from center of eyelet of eyelet shape. 	1.0 to 10.0	0.1mm	*1
S15	Number of stitches of eyelet shape This item sets number of stitches in the upper 90° of eyelet shape. 	1 to 8	1 stitch	*1
S16	Eyelet width This item sets crosswise size of the inside of eyelet shape. Actual needle entry point is the dimension to which S04 Knife groove width, left is added. 	1.0 to 10.0	0.1mm	*1
S17	Eyelet length This item sets lengthwise size of the inside of eyelet shape. 	1.0 to 10.0	0.1mm	*1
S18	Round type shape length This item sets upper length from the center of round type shape. 	1.0 to 5.0	0.1mm	*1
S19	Number of stitches of radial shape This item sets number of stitches in the upper 90° of radial shape. 	1 to 8	1 stitch	*1
S20	Reinforcement of radial shape This item sets with/without reinforcement stitching of radial shape. 	—	—	*1, *2
S21	Pitch at bar-tacking section This item sets sewing pitch of bar-tacking section. 	0.200 to 2.500	0.025mm	—

NO.	Item	Setting range	Edit unit	Remarks
S22	1st clearance This item sets the clearance between 1st bar-tacking and knife groove. This item is applied to all shapes. 	0.0 to 4.0	0.1mm	—
S23	2nd clearance This item sets the clearance between 2nd bar-tacking and knife groove. This item is applied to all shapes. 	0.0 to 4.0	0.1mm	—
S31	Single/double stitching This item selects single or double stitching.  Single stitching  Double stitching	—	—	—
S32	Double stitching cross selection This item selects overlapping stitching or cross stitching at the needle entry of parallel section when setting double stitching.  : Double stitching  : Cross stitching	—	—	*3
S33	Compensation of double stitching width This item sets amount to narrow overedging width of 1st cycle when setting double stitching. 	0.0 to 2.0	0.1mm	*3
S34	Number of times of basting This item sets number of times of basting.  : Without basting  : With basting (Setting of number of times)	0 to 9	1 time	—
S35	Basting pitch This item sets pitch at the time of performing basting. 	1.0 to 5.0	0.1mm	*3
S36	Rolling length of basting This item sets rolling length of needle thread when performing basting. 	2.0 to 20.0	0.1mm	*3
S37	Rolling pitch of basting This item sets rolling pitch of needle thread when performing basting. 	0.2 to 5.0	0.1mm	*3
S38	Rolling width of basting This item sets rolling width of needle thread when performing basting. 	0.0 to 4.0	0.1mm	*3
S39	Lengthwise compensation of needle entry of basting This item sets the amount to move needle entry position back and forth when performing basting more than two cycles. 	0.0 to 2.5	0.1mm	*2, *3
S40	Crosswise compensation of needle entry of basting This item sets the amount to move needle entry position to the right or left when performing basting more than two cycles. 	0.0 to 1.0	0.1mm	*3
S41	Compensation of left side position of basting This item sets the amount to move the sewing reference position of basting from the center of left overedging to the right or left. 	-2.0 to 2.0	0.1mm	*2, *3

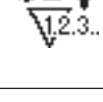







NO.	Item	Setting range	Edit unit	Remarks
S42	Compensation of right side position of basting This item sets the amount to move the sewing reference position of basting from the center of right overedging to the right or left. 	-2.0 to 2.0	0.1mm	*2, *3
S44	Speed setting of basting This item sets speed of basting. 	400 to 4200	100rpm	*3
S51	Left parallel section tension This item sets needle thread tension at left parallel section. 	0 to 200	1	-
S52	Right parallel section tension This item sets needle thread tension at right parallel section. 	0 to 200	1	*2
S53	Left parallel section tension (1st cycle of double stitching) This item sets needle thread tension at left parallel section of 1st cycle at the time of double stitching. 	0 to 200	1	*2, *3
S54	Right parallel section tension (1st cycle of double stitching) This item sets needle thread tension at right parallel section of 1st cycle at the time of double stitching. 	0 to 200	1	*2, *3
S55	Tension at 1st bar-tacking section This item sets needle thread tension at 1st bar-tacking section. 	0 to 200	1	-
S56	Tension at 2nd bar-tacking section This item sets needle thread tension at 2nd bar-tacking section. 	0 to 200	1	*2
S57	Setting of needle thread tension at the start of sewing This item sets needle thread tension of tie stitching at the start of sewing. 	0 to 200	1	-
S58	Setting of needle thread tension of basting This item sets needle thread tension of basting. 	0 to 200	1	*3

NO.	Item	Setting range	Edit unit	Remarks
S59	ACT timing adjustment at the start of 1st bar-tacking This item adjusts needle thread tension output start timing at 1st bar-tacking section. 	-5 to 5	1 stitch	*2
S60	ACT timing adjustment at the start of right overedging This item adjusts needle thread tension output start timing at right overedging section. 	-5 to 5	1 stitch	*2
S61	ACT timing adjustment at the start of 2nd bar-tacking This item adjusts needle thread tension output start timing at 2nd bar-tacking section. 	-5 to 5	1 stitch	*2
S62	Number of stitches of tie stitching at the start of sewing This item sets number of stitches of tie stitching at the start of sewing. 	0 to 8	1 stitch	-
S63	Sewing pitch of tie stitching at the start of sewing This item sets sewing pitch of tie stitching at the start of sewing. 	0.00 to 0.70	0.05mm	*2
S64	Tie stitching width at the start of sewing This item sets tie stitching width at the start of sewing. 	0.0 to 3.0	0.1mm	-
S65	Lengthwise compensation of tie stitching at the start of sewing This item sets start position of tie stitching in lengthwise direction at the start of sewing. 	0.0 to 5.0	0.1mm	*2
S66	Crosswise compensation of tie stitching at the start of sewing This item sets start position of tie stitching in crosswise direction at the start of sewing. 	0.0 to 2.0	0.1mm	*2
S67	Tie stitching width at the end of sewing This item sets tie stitching width at the end of sewing. 	0.1 to 1.5	0.1mm	-
S68	Number of stitches of tie stitching at the end of sewing This item sets number of stitches of tie stitching at the end of sewing. 	0 to 8	1 stitch	-
S69	Lengthwise compensation of tie stitching at the end of sewing This item sets start position of tie stitching in lengthwise direction at the end of sewing. 	0.0 to 5.0	0.1mm	*2
S70	Crosswise compensation of tie stitching at the end of sewing This item sets start position of tie stitching in crosswise direction at the end of sewing. 	0.0 to 2.0	0.1mm	*2

* 1 : Displayed according to the shape

* 2 : Displayed when it is set to with edit. Refer to 12. Method of setting sewing data with/without edit (Instruction Manual).

* 3 : Displayed when the function is selected.

NO.	Item	Setting range	Edit unit	Remarks
S81	Knife motion This item sets "With/without motion" of normal cloth cutting knife.  : Normal knife motion OFF  : Normal knife motion ON	—	—	—
S83	Knife motion at 1st cycle of double stitching This item sets "With/without motion" of cloth cutting knife at 1st cycle when double stitching is performed.  : Normal knife motion OFF  : Normal knife motion ON	—	—	*2, *3
S84	Maximum speed limitation This item sets max. speed limitation of the sewing machine. The maximum value of data edit is equal to the number of revolutions of K07 Maximum speed limitation of the memory switch data. → Refer to 8.-(2) Memory switch list 	400 to 4200	100rpm	—
S86	Pitch of going This item sets sewing pitch of going side of bar-tacking shape (Shape Nos. 27, 28, 29 and 30 of S01). 	0.200 to 2.500	0.025mm	—
S87	Width of going This item sets width of going side of bar-tacking shape (Shape Nos. 27, 28, 29 and 30 of S01). 	0.1 to 3.0	0.05mm	—
S88	Pitch of returning This item sets sewing pitch of returning side of bar-tacking shape (Shape Nos. 27, 28, 29 and 30 of S01). 	0.200 to 2.500	0.025mm	—
S89	Width of returning This item sets width of returning side of bar-tacking shape (Shape Nos. 27, 28, 29 and 30 of S01). 	0.1 to 3.0	0.05mm	—

* 1 : Displayed according to the shape















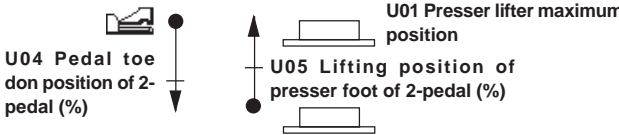

* 2 : Displayed when it is set to with edit. Refer to 12. Method of setting sewing data with/without edit (Instruction Manual).





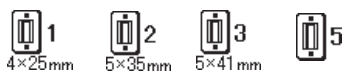









* 3 : Displayed when the function is selected.

(2) Memory switch data list

1) Level 1









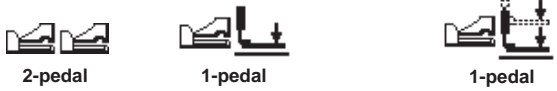

☆ Memory switch data (level 1) are the motion data that the sewing machine has in common and the data that operate on all sewing patterns in common.

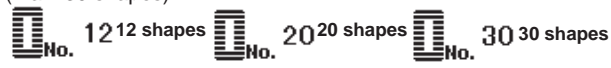









No.	Item	Setting range	Edit unit	Initial value
U01	Presser lifter maximum position Height of maximum position of pedal operation is set. 	0 to 17.0	0.1mm	14.0mm
U02	Presser lifter intermediate position Height of intermediate position of pedal operation is set. 	0 to 14.0	0.1mm	6.0mm
U03	Presser lifter cloth setting position Height of cloth setting position of pedal operation is set. 	0 to 14.0	0.1mm	0.0mm
U04	Pedal toe down position of 2-pedal (%) Operation feeling at the time of 2-pedal is set. Refer to the item below. 	5 to 95	1%	80%
U05	Lifting position of presser foot of 2-pedal (%) Operation feeling at the time of 2-pedal is set.  Pedal toe down amount Presser lifting amount  U04 Pedal toe down position of 2-pedal (%) U05 Lifting position of presser foot of 2-pedal (%) U01 Presser lifter maximum position	5 to 95	1%	50%
U06	Needle thread tension at sewing end setting 	0 to 200	1	35
U07	Needle thread tension at thread trimming setting 	0 to 200	1	35
U09	Soft-start speed setting 1st stitch 	400 to 4200	100rpm	800rpm
U10	Soft-start speed setting 2nd stitch 	400 to 4200	100rpm	800rpm
U11	Soft-start speed setting 3rd stitch 	400 to 4200	100rpm	2000rpm
U12	Soft-start speed setting 4th stitch 	400 to 4200	100rpm	3000rpm
U13	Soft-start speed setting 5th stitch 	400 to 4200	100rpm	4000rpm
U14	Kind of presser Set the kind of the presser. → 7.- (4) Inputting the presser type (Refer to Instruction Manual.) 	–	–	Type 1
U15	Presser size width When type 5 of U14 Kind of presser is set, input the width of the presser. 	3.0 to 10.0	0.1mm	3.0mm
U16	Presser size length When type 5 of U14 Kind of presser is set, input the length of the presser. 	10.0 to 120.0	0.5mm	10.0mm
U17	Sewing start position (Feed direction) Sewing start position in terms of presser is set. Set this item when starting position is desired to be shifted due to overlapped section or the like. 	2.5 to 110.0	0.1mm	2.5mm

No.	Item	Setting range	Edit unit	Initial value
U18	Cloth cutting knife size Input knife size used. 	3.0 to 32.0	0.1mm	32.0mm
U19	Function of plural motions of cloth cutting knife Ineffective/effective  Ineffective  Effective	–	–	Ineffective
U20	Function of thread breakage detection Ineffective/effective  Ineffective  Effective	–	–	Effective
U21	Selection of presser position at the time of ON of READY key (Up/Down) Presser foot position when READY key is pressed is set.  Presser up  Presser down	–	–	Presser Up
U22	Selection of the position of presser foot at the time of the end of sewing (Up/Down) This item sets the position of presser foot at the time of the end of sewing. (Effective only at the time of 1-pedal setting)  Presser up  Presser down	–	–	Presser Up
U23	Needle thread trimming motion start distance Distance from the start of sewing to the start of needle thread trimmer release motion is inputted. 	0 to 15.0	0.1mm	1.0mm
U24	Bobbin thread trimming motion start distance Distance from the start of sewing to the start of bobbin thread trimmer release motion is inputted. 	0 to 15.0	0.1mm	1.5mm
U25	Counter updating unit Unit to update sewing counter is set. 	1 to 30	1	1
U26	Total number of stitches Non-display/Display  Non-display  Display	–	–	Non-display

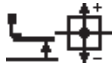
2) Level 2

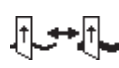
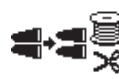
☆ Press **M** key for three seconds and it is possible to edit.

NO.	Item	Setting range	Edit unit	Initial value
K01	Pedal selection Pedal type is set. → 3. How to use the pedal (Refer to Instruction Manual.)  2-pedal 1-pedal 1-pedal (Without intermediate position) (With intermediate position)	—	—	2-pedal
K02	Parameter setting change Permitted/Prohibited Prohibition of change of sewing data and memory switch data is set. 	—	—	Change permitted
K03	Function of prohibition of selection of kind of presser Permitted/Prohibited Prohibition of change of U14 Kind of presser is set. 	—	—	Change permitted
K04	Sewing shape selection level Number of sewing shapes which can be sewn can be increased. (Max. 30 shapes) 	—	—	12 shapes
K05	Cloth cutting knife power Output power of cloth cutting knife is set. 0 : Min. power → 3 : Max. power 	0 to 3	1	1
K06	Selection of machine type Type of sewing machine head is set. 0 : Standard type 1 : Dry head type 	0 to 1	1	0 (Standard type)
K07	Max. speed limitation speed setting Max. speed of sewing machine can be limited. When K06 Selection of machine type is set to dry head type, max. speed is automatically limited to 3,300 rpm. 	400 to 4200	100rpm	3600 rpm
K08	Compensation of unsteady needle thread tension Output value of needle thread tension is wholly offset and compensated. 	-30 to 30	1	0
K09	Output time of needle thread tension changed value When data related to needle thread tension is changed, the changed value is output as long as the set-up time. 	0 to 20	1s	0s
K10	Function of origin retrieval each time Origin retrieval is performed after completion of sewing or completion of cycle. 	—	—	Without
K11	Needle up by reverse run Permitted/Prohibited When U01 Presser lifter maximum position is set to 14.0 mm or more, motion of needle up by reverse run is automatically performed and the machine stops. Prohibition of the motion can be set. 	—	—	Permitted
K12	Knife solenoid lowering time setting 	25 to 100	5ms	35

No.	Item	Setting range	Edit unit	Initial value
K13	Knife solenoid lifting time setting 	5 to 100	5ms	15
K14	Knife cylinder lowering time (Optional) 	5 to 300	5ms	50
K15	Y-feed motor origin compensation 	-120 to 400	1 pulse (0.025mm)	0
K16	Needle-rocking motor origin compensation 	-10 to 10	1 pulse (0.05mm)	0
K17	Presser lifter motor origin compensation 	-100 to 10	1 pulse (0.05mm)	0
K18	Pattern selection function under sewing mode Ineffective/effective 	-	-	Ineffective
K19	Thread trimming on the way in continuous stitching Permitted/Prohibited 	-	-	Permitted
K20	Cloth cutting knife return power This item sets output power at the time of returning the cloth cutting knife. 0 : Min. power → 3 : Max. power 	0 to 3	1	0
K21	Release amount of bobbin thread trimmer at the start of sewing This item sets the amount of releasing the bobbin thread trimmer at the start of sewing. 	0 to 15	1 pulse	8
K51	Needle thread trimming adjustment mode start Needle thread trimming adjustment motion starts with READY key ON. 	-	-	-
K52	Bobbin thread trimming adjustment mode start Bobbin thread trimming adjustment motion starts with READY key ON. 	-	-	-
* K53	Sensor check mode start Sensor check starts with READY key ON. 	-	-	-



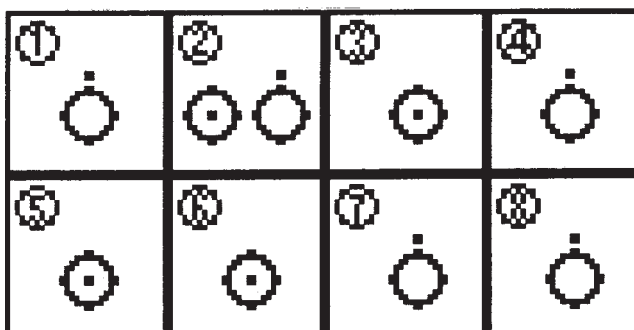

* When READY key  is pressed at **K53**, the screen below is displayed.





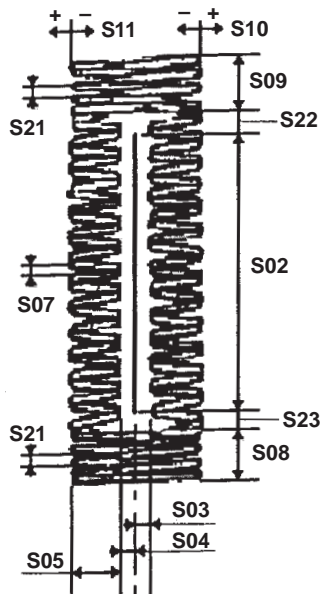
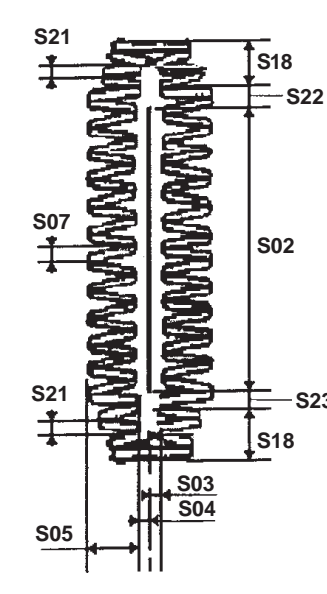

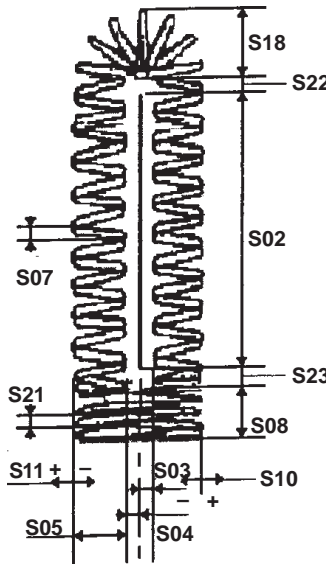
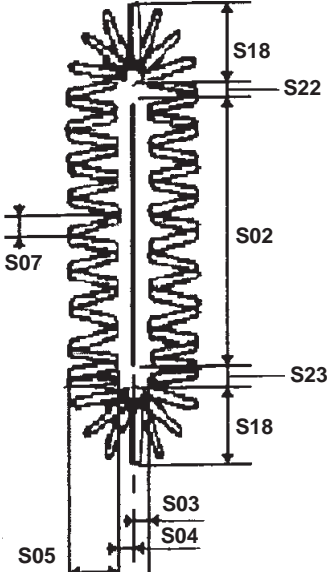

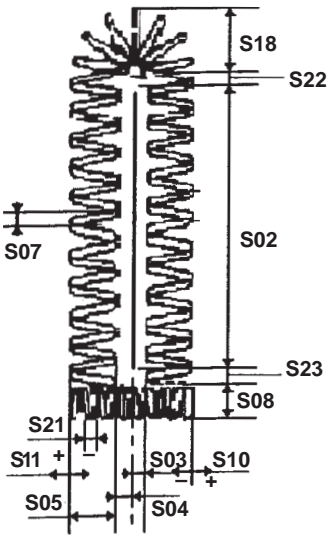
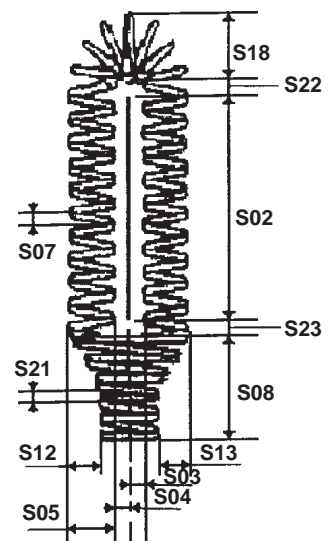

- ① Pedal volume
- ② Pedal sensor
- ③ Thread breakage detection
- ④ Cloth cutting knife sensor
- ⑤ Head tilt sensor
- ⑥ STOP switch
- ⑦ Needle rocking sensor
- ⑧ Machine woodruff plate sensor

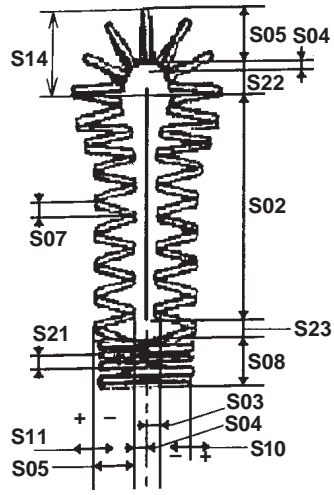
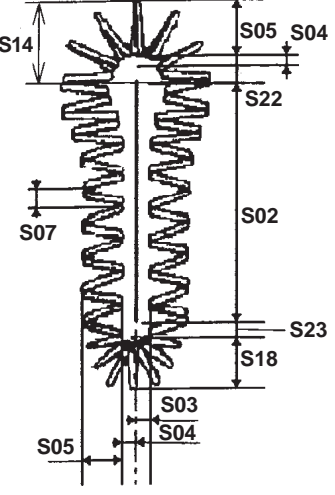

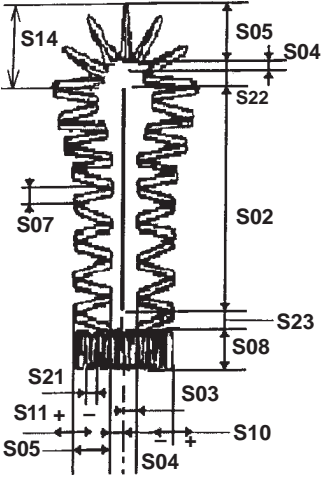
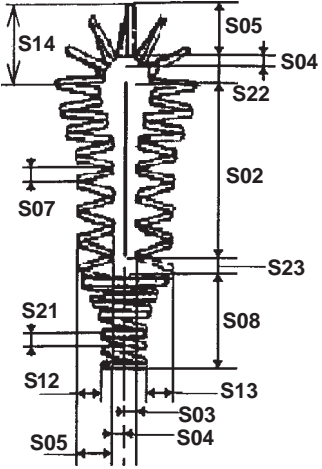

 : ON  : OFF

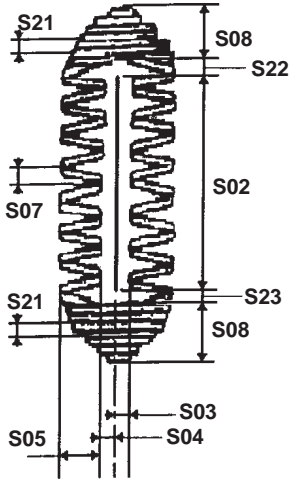
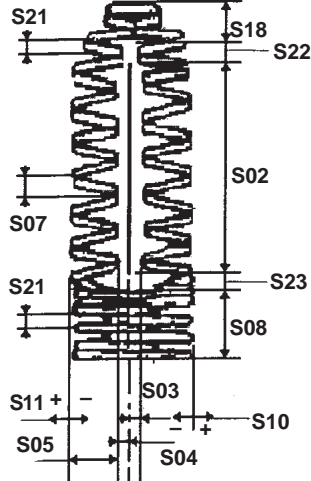

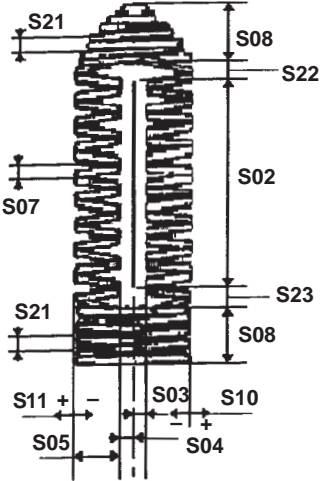
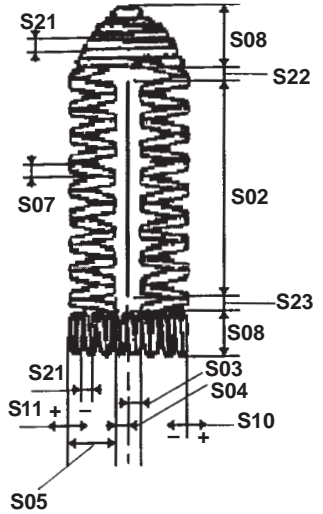

9. EXPLANATION OF SHAPE

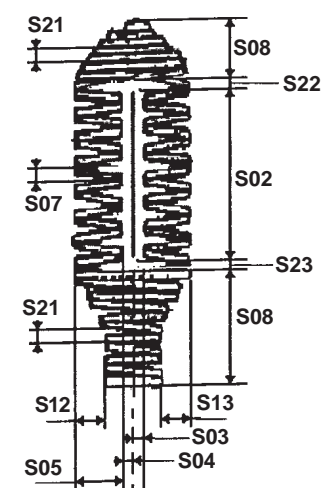
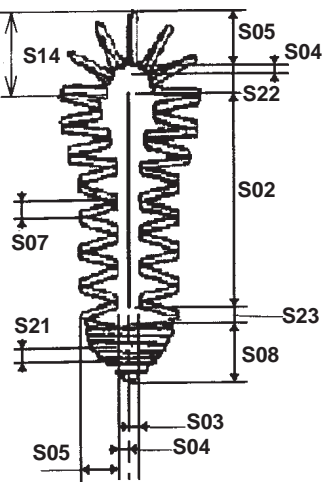

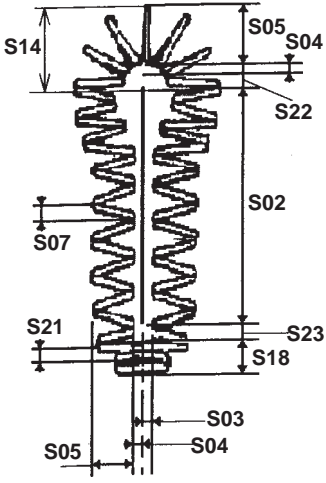
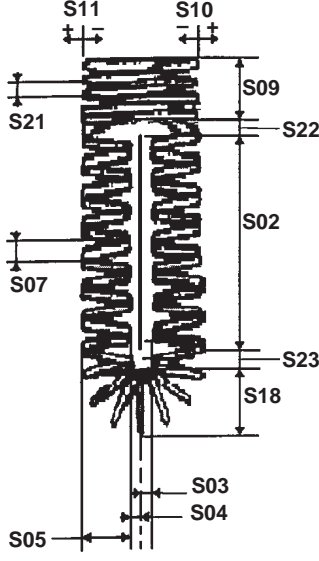

(1) Square type		(2) Round type	
	<p>S02 : Cloth cutting length S03 : Knife groove width, right S04 : Knife groove width, left S05 : Overredging width, left S07 : Pitch at parallel section S08 : 2nd bar-tacking length S09 : 1st bar-tacking length S10 : Bar-tacking width, right compensation S11 : Bar-tacking width, left compensation S21 : Pitch at bar-tacking section S22 : 1st clearance S23 : 2nd clearance</p>		<p>S02 : Cloth cutting length S03 : Knife groove width, right S04 : Knife groove width, left S05 : Overredging width, left S07 : Pitch at parallel section S18 : Round type shape length S21 : Pitch at bar-tacking section S22 : 1st clearance S23 : 2nd clearance</p>
<p>PANEL DISPLAY</p> 	<p>PANEL DISPLAY</p> 		
	(3) Radial square type		(4) Radial type
	<p>S02 : Cloth cutting length S03 : Knife groove width, right S04 : Knife groove width, left S05 : Overredging width, left S07 : Pitch at parallel section S08 : 2nd bar-tacking length S10 : Bar-tacking width, right compensation S11 : Bar-tacking width, left compensation S18 : Round type shape length S21 : Pitch at bar-tacking section S22 : 1st clearance S23 : 2nd clearance</p>		<p>S02 : Cloth cutting length S03 : Knife groove width, right S04 : Knife groove width, left S05 : Overredging width, left S07 : Pitch at parallel section S18 : Round type shape length S22 : 1st clearance S23 : 2nd clearance</p>
<p>PANEL DISPLAY</p> 	<p>PANEL DISPLAY</p> 		

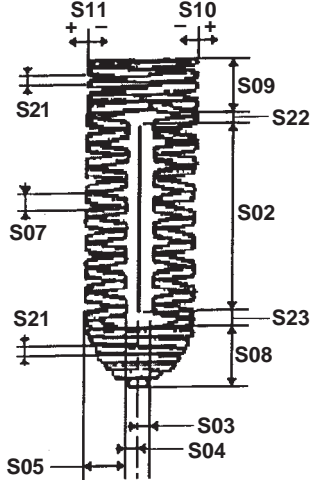
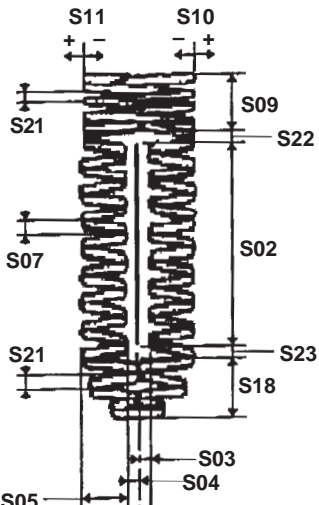

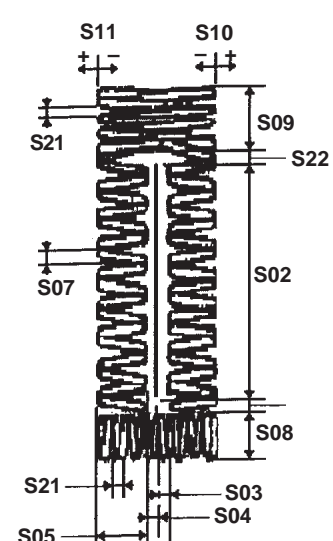
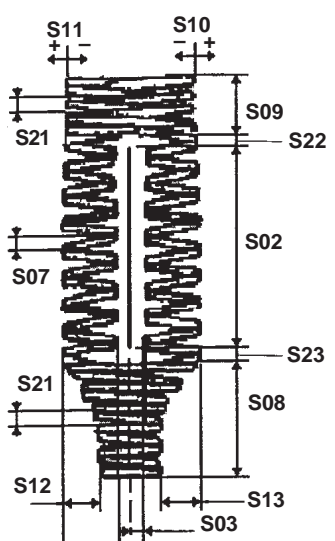

<p style="text-align: center;">(5) Radial straight bar-tacking type</p> 	<p>S02 : Cloth cutting length S03 : Knife groove width, right S04 : Knife groove width, left S05 : Overredging width, left S07 : Pitch at parallel section S08 : 2nd bar-tacking length S10 : Bar-tacking width, right compensation S11 : Bar-tacking width, left compensation S18 : Round type shape length S21 : Pitch at bar-tacking section S22 : 1st clearance S23 : 2nd clearance</p>	<p style="text-align: center;">(6) Radial taper bar-tacking type</p> 	<p>S02 : Cloth cutting length S03 : Knife groove width, right S04 : Knife groove width, left S05 : Overredging width, left S07 : Pitch at parallel section S08 : 2nd bar-tacking length S12 : Taper bar-tacking offset, left S13 : Taper bar-tacking offset, right S18 : Round type shape length S21 : Pitch at bar-tacking section S22 : 1st clearance S23 : 2nd clearance</p>
<p>PANEL DISPLAY</p> 	<p>PANEL DISPLAY</p> 		
<p style="text-align: center;">(7) Eyelet square type</p> 	<p>S02 : Cloth cutting length S03 : Knife groove width, right S04 : Knife groove width, left S05 : Overredging width, left S07 : Pitch at parallel section S08 : 2nd bar-tacking length S10 : Bar-tacking width, right compensation S11 : Bar-tacking width, left compensation S14 : Eyelet shape length S21 : Pitch at bar-tacking section S22 : 1st clearance S23 : 2nd clearance</p>	<p style="text-align: center;">(8) Eyelet radial type</p> 	<p>S02 : Cloth cutting length S03 : Knife groove width, right S04 : Knife groove width, left S05 : Overredging width, left S07 : Pitch at parallel section S14 : Eyelet shape length S18 : Round type shape length S22 : 1st clearance S23 : 2nd clearance</p>
<p>PANEL DISPLAY</p> 	<p>PANEL DISPLAY</p> 		

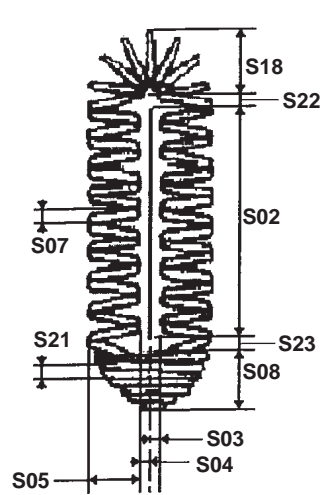
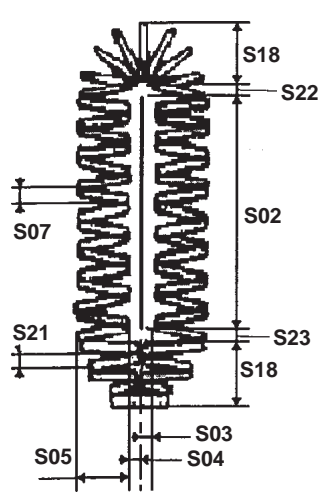

<p style="text-align: center;">(9) Eyelet straight bar-tacking type</p> 	<p>S02 : Cloth cutting length S03 : Knife groove width, right S04 : Knife groove width, left S05 : Overedging width, left S07 : Pitch at parallel section S08 : 2nd bar-tacking length S10 : Bar-tacking width, right compensation S11 : Bar-tacking width, left compensation S14 : Eyelet shape length S21 : Pitch at bar-tacking section S22 : 1st clearance S23 : 2nd clearance</p>	<p style="text-align: center;">(10) Eyelet taper bar-tacking type</p> 	<p>S02 : Cloth cutting length S03 : Knife groove width, right S04 : Knife groove width, left S05 : Overedging width, left S07 : Pitch at parallel section S08 : 2nd bar-tacking length S12 : Taper bar-tacking offset, left S13 : Taper bar-tacking offset, right S14 : Eyelet shape length S21 : Pitch at bar-tacking section S22 : 1st clearance S23 : 2nd clearance</p>
<p>PANEL DISPLAY</p> 	<p>PANEL DISPLAY</p> 		
<p style="text-align: center;">(11) Semilunar type</p> 	<p>S02 : Cloth cutting length S03 : Knife groove width, right S04 : Knife groove width, left S05 : Overedging width, left S07 : Pitch at parallel section S08 : 2nd bar-tacking length S21 : Pitch at bar-tacking section S22 : 1st clearance S23 : 2nd clearance</p>	<p style="text-align: center;">(12) Round square type</p> 	<p>S02 : Cloth cutting length S03 : Knife groove width, right S04 : Knife groove width, left S05 : Overedging width, left S07 : Pitch at parallel section S08 : 2nd bar-tacking length S10 : Bar-tacking width, right compensation S11 : Bar-tacking width, left compensation S18 : Round type shape length S21 : Pitch at bar-tacking section S22 : 1st clearance S23 : 2nd clearance</p>
<p>PANEL DISPLAY</p> 	<p>PANEL DISPLAY</p> 		

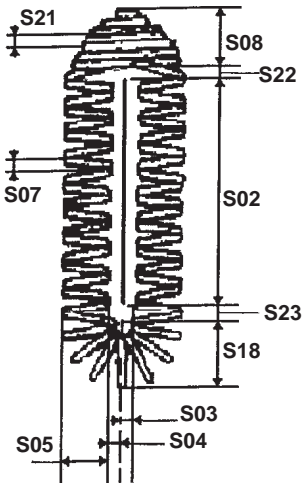
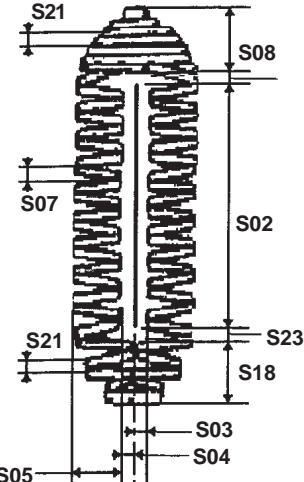
<p style="text-align: center;">(13) Semilunar square type</p> 	<p>S02 : Cloth cutting length S03 : Knife groove width, right S04 : Knife groove width, left S05 : Overedging width, left S07 : Pitch at parallel section S08 : 2nd bar-tacking length S10 : Bar-tacking width, right compensation S11 : Bar-tacking width, left compensation S21 : Pitch at bar-tacking section S22 : 1st clearance S23 : 2nd clearance</p>	<p style="text-align: center;">(14) Semilunar straight bar-tacking type</p> 	<p>S02 : Cloth cutting length S03 : Knife groove width, right S04 : Knife groove width, left S05 : Overedging width, left S07 : Pitch at parallel section S08 : 2nd bar-tacking length S10 : Bar-tacking width, right compensation S11 : Bar-tacking width, left compensation S21 : Pitch at bar-tacking section S22 : 1st clearance S23 : 2nd clearance</p>
<p>PANEL DISPLAY</p> 	<p>PANEL DISPLAY</p> 		
<p style="text-align: center;">(15) Semilunar taper bar-tacking type</p> 	<p>S02 : Cloth cutting length S03 : Knife groove width, right S04 : Knife groove width, left S05 : Overedging width, left S07 : Pitch at parallel section S08 : 2nd bar-tacking length S12 : Taper bar-tacking offset, left S13 : Taper bar-tacking offset, right S21 : Pitch at bar-tacking section S22 : 1st clearance S23 : 2nd clearance</p>	<p style="text-align: center;">(16) Eyelet semilunar type</p> 	<p>S02 : Cloth cutting length S03 : Knife groove width, right S04 : Knife groove width, left S05 : Overedging width, left S07 : Pitch at parallel section S08 : 2nd bar-tacking length S14 : Eyelet shape length S21 : Pitch at bar-tacking section S22 : 1st clearance S23 : 2nd clearance</p>
<p>PANEL DISPLAY</p> 	<p>PANEL DISPLAY</p> 		

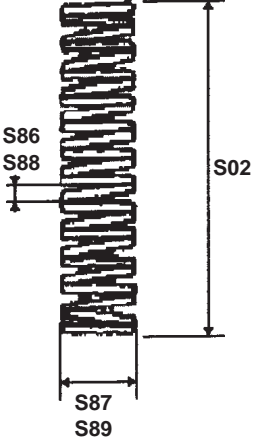
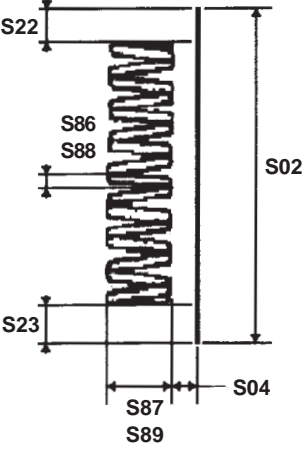
<p style="text-align: center;">(17) Eyelet round type</p> 	<p>S02 : Cloth cutting length S03 : Knife groove width, right S04 : Knife groove width, left S05 : Overedging width, left S07 : Pitch at parallel section S14 : Eyelet shape length S18 : Round type shape length S21 : Pitch at bar-tacking section S22 : 1st clearance S23 : 2nd clearance</p>	<p style="text-align: center;">(18) Square radial type</p> 	<p>S02 : Cloth cutting length S03 : Knife groove width, right S04 : Knife groove width, left S05 : Overedging width, left S07 : Pitch at parallel section S09 : 1st bar-tacking length S10 : Bar-tacking width, right compensation S11 : Bar-tacking width, left compensation S18 : Round type shape length S21 : Pitch at bar-tacking section S22 : 1st clearance S23 : 2nd clearance</p>
<p>PANEL DISPLAY</p> 		<p>PANEL DISPLAY</p> 	
<p style="text-align: center;">(19) Square semilunar type</p> 	<p>S02 : Cloth cutting length S03 : Knife groove width, right S04 : Knife groove width, left S05 : Overedging width, left S07 : Pitch at parallel section S08 : 2nd bar-tacking length S09 : 1st bar-tacking length S10 : Bar-tacking width, right compensation S11 : Bar-tacking width, left compensation S21 : Pitch at bar-tacking section S22 : 1st clearance S23 : 2nd clearance</p>	<p style="text-align: center;">(20) Square round type</p> 	<p>S02 : Cloth cutting length S03 : Knife groove width, right S04 : Knife groove width, left S05 : Overedging width, left S07 : Pitch at parallel section S09 : 1st bar-tacking length S10 : Bar-tacking width, right compensation S11 : Bar-tacking width, left compensation S18 : Round type shape length S21 : Pitch at bar-tacking section S22 : 1st clearance S23 : 2nd clearance</p>
<p>PANEL DISPLAY</p> 		<p>PANEL DISPLAY</p> 	

(21) Square straight bar-tacking type	(22) Square taper bar-tacking type
 <p>S02 : Cloth cutting length S03 : Knife groove width, right S04 : Knife groove width, left S05 : Overedging width, left S07 : Pitch at parallel section S08 : 2nd bar-tacking length S09 : 1st bar-tacking length S10 : Bar-tacking width, right compensation S11 : Bar-tacking width, left compensation S21 : Pitch at bar-tacking section S22 : 1st clearance S23 : 2nd clearance</p>	 <p>S02 : Cloth cutting length S03 : Knife groove width, right S04 : Knife groove width, left S05 : Overedging width, left S07 : Pitch at parallel section S08 : 2nd bar-tacking length S09 : 1st bar-tacking length S10 : Bar-tacking width, right compensation S11 : Bar-tacking width, left compensation S12 : Taper bar-tacking offset, left S13 : Taper bar-tacking offset, right S21 : Pitch at bar-tacking section S22 : 1st clearance S23 : 2nd clearance</p>
PANEL DISPLAY 	PANEL DISPLAY 
(23) Radial semilunar type	(24) Radial round type
 <p>S02 : Cloth cutting length S03 : Knife groove width, right S04 : Knife groove width, left S05 : Overedging width, left S07 : Pitch at parallel section S08 : 2nd bar-tacking length S18 : Round type shape length S21 : Pitch at bar-tacking section S22 : 1st clearance S23 : 2nd clearance</p>	 <p>S02 : Cloth cutting length S03 : Knife groove width, right S04 : Knife groove width, left S05 : Overedging width, left S07 : Pitch at parallel section S18 : Round type shape length S21 : Pitch at bar-tacking section S22 : 1st clearance S23 : 2nd clearance</p>
PANEL DISPLAY 	PANEL DISPLAY 

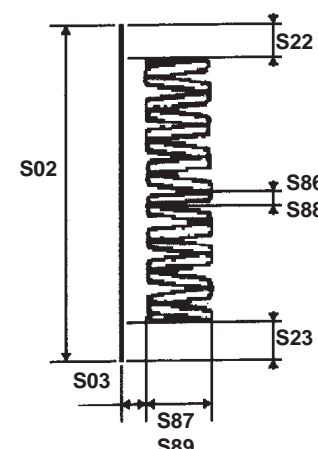
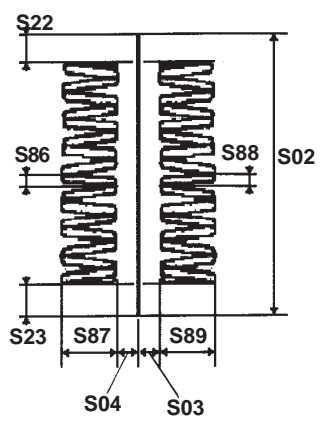
<p style="text-align: center;">(25) Semilunar radial type</p> 	<p>S02 : Cloth cutting length S03 : Knife groove width, right S04 : Knife groove width, left S05 : Overedging width, left S07 : Pitch at parallel section S08 : 2nd bar-tacking length S18 : Round type shape length S21 : Pitch at bar-tacking section S22 : 1st clearance S23 : 2nd clearance</p>	<p style="text-align: center;">(26) Semilunar round type</p> 	<p>S02 : Cloth cutting length S03 : Knife groove width, right S04 : Knife groove width, left S05 : Overedging width, left S07 : Pitch at parallel section S08 : 2nd bar-tacking length S18 : Round type shape length S21 : Pitch at bar-tacking section S22 : 1st clearance S23 : 2nd clearance</p>
<p>PANEL DISPLAY</p>  <p style="text-align: right;">25</p>	<p>PANEL DISPLAY</p>  <p style="text-align: right;">26</p>		
<p style="text-align: center;">(27) Bar-tacking</p> 	<p>S02 : Cloth cutting length S86 : Pitch of going S87 : Width of going S88 : Pitch of returning S89 : Width of returning</p>	<p style="text-align: center;">(28) Bar-tacking, right cut</p> 	<p>S02 : Cloth cutting length S04 : Knife groove width, left S22 : 1st clearance S23 : 2nd clearance S86 : Pitch of going S87 : Width of going S88 : Pitch of returning S89 : Width of returning</p>
<p>PANEL DISPLAY</p>  <p style="text-align: right;">27</p>	<p>PANEL DISPLAY</p>  <p style="text-align: right;">28</p>		

(29) Bar-tacking, left cut	(30) Bar-tacking, center cut
 <p> S02 : Cloth cutting length S03 : Knife groove width, right S22 : 1st clearance S23 : 2nd clearance S86 : Pitch of going S87 : Width of going S88 : Pitch of returning S89 : Width of returning </p>	 <p> S02 : Cloth cutting length S03 : Knife groove width, right S04 : Knife groove width, left S22 : 1st clearance S23 : 2nd clearance S86 : Pitch of going S87 : Width of going S88 : Pitch of returning S89 : Width of returning </p>
PANEL DISPLAY 	PANEL DISPLAY 

10. DETAILED EXPLANATION OF CONTINUOUS STITCHING

* The figure below is an example for reference when the presser of feed 120 mm is used.

For the details, refer to the item “(1) Points of replacement of the feed for 70 mm or 120 mm in 14. OTHERS.

(1) A series of motions of continuous stitching in the pattern data in the figure on the right side is performed in the following order and sewing is performed.

Move of jump feed amount B → Sewing of pattern No. A →

Move of jump feed amount D → Sewing of pattern No. C →

Move of jump feed amount F → Sewing of pattern No. E →

Move of jump feed amount H → Sewing of pattern No. G

The actual sewing arrangement is as shown below.

Example for reference

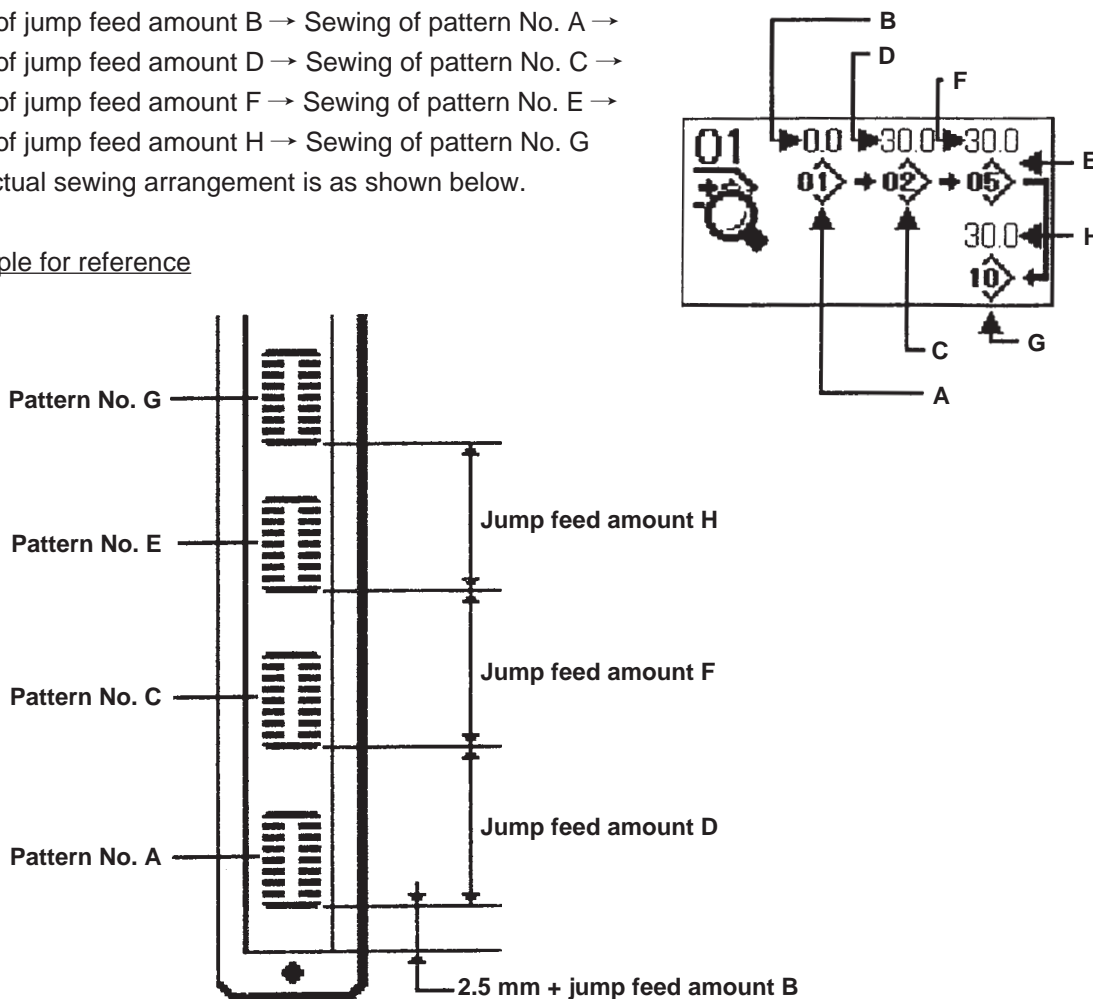

A space of 2.5 mm from the presser to the needle is set when the feed is in the origin position at the time of delivery.

Therefore, the position of starting sewing of pattern A becomes the space where 2.5 mm is added to jump feed amount B.





















(2) Special continuous stitching





















In the continuous stitching, it is possible that thread trimming on the way during continuous stitching cannot be performed by setting to “Prohibited” of **K19** Thread trimming on the way in continuous stitching of memory switch level 2.













In case of without the setting of **K19** Thread trimming in continuous stitching, all jump feed amounts inputted in the continuous stitching are neglected, and the sewing machine sews the sewing patterns which have been inputted at the same places.

By this function, the double stitching can be performed using the sewing patterns which are different in shape or pitch.

11. ERROR CODE LIST

Error code	Display	Description	How to recover	Place of recovery
E001		Contact of initialization of EEPROM of MAIN CONTROL p.c.b. When data is not written in EEPROM or data is broken, data is automatically initialized and the initialization is informed.	Turn OFF the power.	
E007		Main shaft motor-lock When large needle resistance sewing product is sewn	Turn OFF the power	
E018	TYPE 	Type of EEPROM is wrong. When the type of mounted EEPROM is wrong	Turn OFF the power.	
E023		Detection of step-out of presser lifting motor When step-out of motor is detected at the time when presser lifting motor passes origin sensor or starts operation.	Possible to re-start after pressing reset key.	Standard screen
E024		Pattern data size over When sewing cannot be performed since total size of continuous stitching data or size of downloaded data is too large.	Possible to re-start after pressing reset key.	Standard screen
E025		Detection of step-out of needle thread trimmer motor When step-out of motor is detected at the time when needle thread trimmer motor passes origin sensor or starts operation.	Possible to re-start after pressing reset key.	Standard screen
E026		Detection of step-out of bobbin thread trimmer motor When step-out of motor is detected at the time when bobbin thread trimmer motor passes origin sensor or starts operation.	Possible to re-start after pressing reset key.	Standard screen
E030		Needle bar upper position failure When needle does not stop at UP position even with needle UP operation at the time of starting sewing machine.	Possible to re-start after pressing reset key.	Standard screen
E050		Stop switch When stop switch is pressed during machine running.	Possible to re-start after pressing reset key.	Step screen
E052		Thread breakage detection error When thread breakage has occurred during machine running.	Possible to re-start after pressing reset key.	Step screen.
E061		Memory switch data error When memory switch data is broken or revision is old.	Turn OFF the power.	
E062		Sewing data error When sewing data is broken or revision is old.	Turn OFF the power.	
E099		Interference of knife lowering command with thread trimming motion When inserting position of knife command is improper and knife command interferes with thread trimming motion in case of motion by data from external input device.	Possible to re-start after pressing reset key.	Standard screen
E302		Confirmation of tilt of machine head When tilt of machine head sensor is OFF.	Possible to re-start after pressing reset key.	Standard screen
E303		Z phase sensor error of main shaft motor Z phase sensor of sewing machine motorencoder is abnormal.	Turn OFF the power.	
E304		Cloth cutting knife sensor error When sensor is not OFF while knife is lowered.	Turn OFF the power.	
E486		Eyelet knife length error Eyelet knife length is too short to form the shape in case of eyelet shape.	Possible to re-enter after pressing reset key.	Sewing data edit screen [S17] Eyelet knife length
E487		Eyelet shape length error Eyelet shape length is too short to form the shape in case of eyelet shape.	Possible to re-enter after pressing reset key.	Sewing data edit screen [S14] Eyelet shape length
E488		Taper bar-tacking compensation error When bar-tacking length is too short to form the shape in case of taper bar-tacking shape.	Possible to re-enter after pressing reset key.	Sewing data edit screen [S08] 2nd bar-tacking length
E489		Knife size error (at the time of plural motions of knife) When knife size is larger than cloth cutting knife size.	Possible to re-enter after pressing reset key.	Sewing data edit screen [S02] Cloth cut length

Error code	Display	Description	How to recover	Place of recovery
E492		Presser size over of basting When stitching data of basting exceeds presser size.	Possible to re-enter after pressing reset key.	Sewing data edit screen [S40] Basting needle entry compensation
E493		Presser size over of tie stitching at sewing end When stitching data of tie stitching at sewing end exceeds presser size.	Possible to re-enter after pressing reset key.	Sewing data edit screen [S67] Tie stitching at sewing end width
E494		Presser size over of tie stitching at sewing start When stitching data of tie stitching at sewing start exceeds presser size.	Possible to re-enter after pressing reset key.	Sewing data edit screen [S64] Tie stitching at sewing start width
E495		Presser size error (Width direction : right only) When stitching data exceeds the size of right only of width direction of presser.	Possible to re-enter after pressing reset key.	Sewing data edit screen [S03] Knife groove width, right or [S06] Ratio of right and left shapes
E496		Presser size error (Width direction : left only) When stitching data exceeds the size of left only of width direction of presser.	Possible to re-enter after pressing reset key.	Sewing data edit screen [S04] Knife groove width, left or [S06] Ratio of right and left shapes
E497		Presser size error (Length direction : front) When stitching data exceeds the size of front of length direction of presser.	Possible to re-enter after pressing reset key.	Standard screen
E498		Presser size error (Width direction : right and left) When stitching data exceeds the size of both right and left of width direction of presser.	Possible to re-enter after pressing reset key.	Sewing data edit screen [S05] Overedging width, left
E499		Presser size error (Length direction : rear) When stitching data exceeds the size of rear of length direction of presser.	Possible to re-enter after pressing reset key.	Sewing data edit screen [S02] Cloth cut length
E703		Panel is connected to the machine other than supposed. (Machine type error) When machine type code of system is improper in case of initial communication.	Turn OFF the power.	
E704		Nonagreement of system version When version of system software is improper in case of initial communication.	Turn OFF the power.	
E730		Main shaft motor encoder defectiveness or phase-out When encoder of sewing machine motor is abnormal.	Turn OFF the power.	
E731		Main motor hole sensor defectiveness or position sensor defectiveness When hole sensor or position sensor of sewing machine motor is defective.	Turn OFF the power.	
E733		Reverse rotation of main shaft motor When sewing machine motor rotates in reverse direction.	Turn OFF the power	
E801		Phase-lack of power When phase-lack of input power occurs.	Turn OFF the power.	
E802		Power instantaneous cut detection When input power is instantaneously OFF.	Turn OFF the power.	
E811		Overvoltage When input power is 280V or more.	Turn OFF the power.	
E813		Low voltage When input voltage is 150V or less.	Turn OFF the power.	
E901		Abnormality of main shaft motor IPM When IPM of servo control p.c.b. is abnormal.	Turn OFF the power.	
E902		Overcurrent of main shaft motor When current flows excessively to sewing machine motor.	Turn OFF the power.	
E903		Abnormality of stepping motor power When stepping motor power of servo control p.c.b. fluctuates $\pm 15\%$ or more.	Turn OFF the power.	

Error code	Display	Description	How to recover	Place of recovery
E904		Abnormality of solenoid power When solenoid power of servo control p.c.b. fluctuates $\pm 15\%$ or more.	Turn OFF the power.	
E905		Abnormality of temperature of heat sink for servo control p.c.b. When temperature of heat sink of servo control p.c.b. is 85 C or more.	Turn OFF the power	
E907		Needle rock motor origin retrieval error When origin sensor signal is not inputted at the time of origin retrieval motion.	Turn OFF the power.	
E908		Lengthwise feed motor origin retrieval error When origin sensor signal is not inputted at the time of origin retrieval motion.	Turn OFF the power	
E909		Needle thread trimmer motor origin retrieval error When origin sensor signal is not inputted at the time of origin retrieval motion.	Turn OFF the power.	
E910		Presser motor origin retrieval error When origin sensor signal is not inputted at the time of origin retrieval motion.	Turn OFF the power	
E911		Bobbin thread trimmer motor origin retrieval error When origin sensor signal is not inputted at the time of origin retrieval motion.	Turn OFF the power.	
E915		Abnormality of communication between operation panel and main CPU When abnormality occurs in communication.	Turn OFF the power	
E916		Abnormality of communication between main CPU and main shaft CPU When abnormality occurs in communication.	Turn OFF the power.	
E918		Abnormality of temperature of heat sink for main control p.c.b. When temperature of heat sink of main control p.c.b. is 85 C or more.	Turn OFF the power	
E943		Defectiveness of EEPROM of main control p.c.b. When data writing to EEPROM is not performed.	Turn OFF the power.	
E946		Defectiveness of writing to EEPROM of head relay p.c.b. When data writing to EEPROM is not performed.	Turn OFF the power	
E999		When cloth cutting knife does not return When the knife is held lowered	Turn OFF the power	

12. ELECTRICAL COMPONENTS

(1) Change of data ROM

For this machine, EEPROMs below can be used as data ROM.

32k byte EEPROM is mounted as standard. However, when a larger capacity is required in case of the external input or the like, it can be upgraded to 128k byte EEPROM.

Capacity	Name of part	JUKI Part No.	Remarks
32k byte	HN58C256AP-10 (HITACHI)	HL011940000	Provided as standard
128k byte	HN58C1001P-15 (HITACHI)	HL020470000	

When mounting the data ROM, perform as shown in the figure below.

In addition, be sure to perform jumper setting.

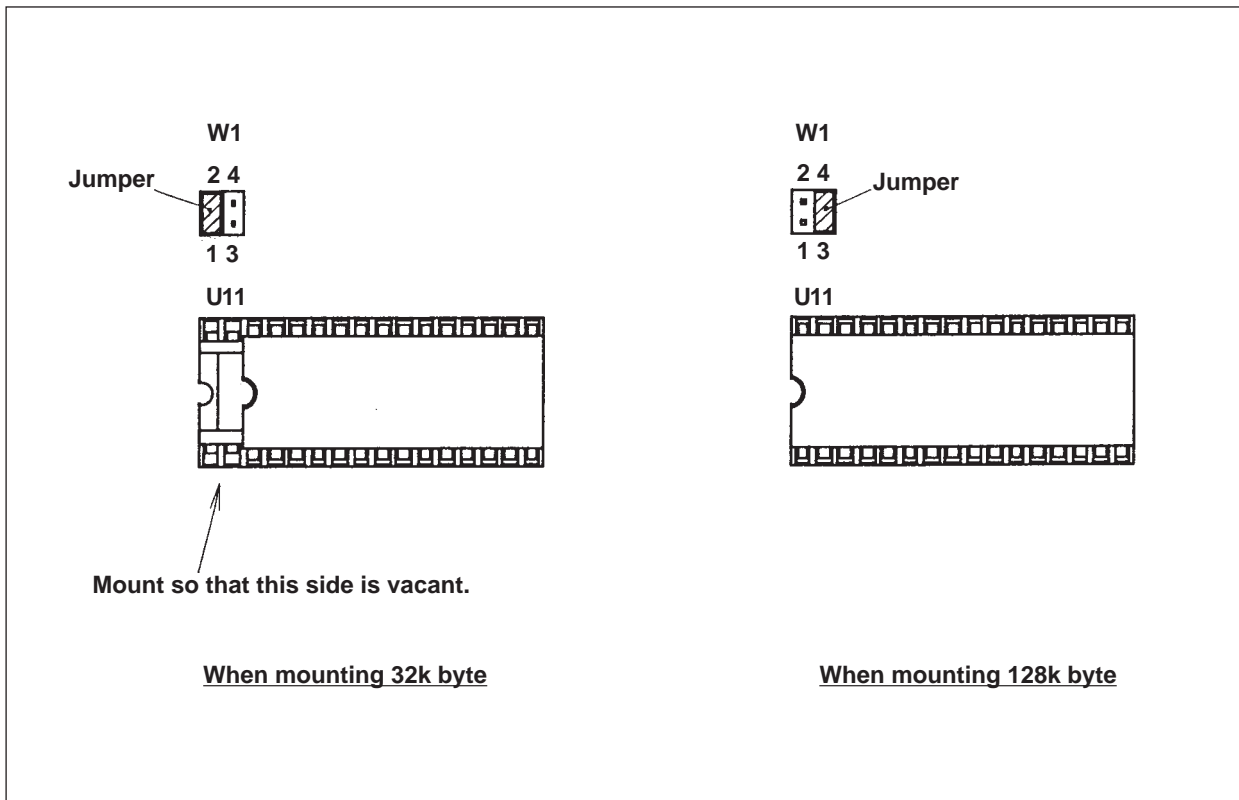

(2) Adaptation to the high voltage

This machine is adaptable to single-phase 100 to 120V and 3-phase 200 to 240V power voltage.

When using this machine with 380 to 415V power voltage, the externally installed transformer is separately required.

Name of part	JUKI Part No.
High voltage transformer (asm.)	40005422

A complete set of transformer main body, connecting cord, fitting screws, etc. is included in the aforementioned part. Therefore, it is possible to be adaptable to the high voltage with simple work.

When installing it, refer to the Instruction Manual for installation attached to the transformer.

(3) DIP switch

Keep DIP switches mounted on the respective printed circuit boards in the state of delivery (all OFF).

(4) Adaptation to the PK pedal

PK pedals below can be connected to the machine.

Name of part	JUKI Part No.	Remarks
PK-51	GPK510010B0	2-pedal type for standing work
PK-57	GPK570010B0	1-pedal 2-step type for standing work

When using PK pedal, the relay cord below is necessary.

Name of part	JUKI Part No.	Remarks
PK pedal relay cord (asm.)	40003493	Common to PK-51 and PK-57

1. Connecting procedure

- (1) Remove connector CN41 (white • 6P) of MAIN p.c.b. in the control box. The connector which has been removed is the connector of the pedal provided as standard. Use it in case of need.
- (2) Connect connector (CN41) of the relay cord to CN41.
- (3) Connect connector (CN41) of the relay cord with the connector of PK pedal. In case of PK-57, the connection is completed with the work above. Besides, in case of PK-57, the earth line protrudes at the connector section. However, it is not necessary to connect it.
- (4) In case of PK-57, remove the cover and perform the change of connection of the micro switch located inside the pedal. Change the connection of micro switch (upper side) in which the switch button is pressed when the pedal is set to free from NC (normal close) to NO (normal open).

2. Setting procedure

- (1) In case of PK-51
 - ① Set L07 (effective/ineffective) of level 3 of the memory switch to "Effective".
 - ② Select "PK-51" with K01 (pedal selection) of level 2 of the memory switch.
- (2) In case of PK-57
Select "Without 1-pedal intermediate position" with K01 (pedal selection) of level 2 of the memory switch.

(5) Fuse list

Fuse list mounted on the respective printed circuit boards in the control box is shown in the table below.

No.	Location	Kind	JUKI Part No.	Remarks
①	SDC p.c.b. F1	250V/5A time-lag fuse ϕ 5.2 X L20	HF0013050P0	For stepping motor/knife solenoid power (+48V) protection Mounted on the fuse clip 1 pc. is packed together as accessories.
②	SDC p.c.b. F2	250V/3.15A time-lag fuse ϕ 5.2 X L20	HF00130315S	For stepping motor/tension solenoid power (+33V) protection Mounted on the fuse clip 1 pc. is packed together as accessories.
③	SDC p.c.b. F3	250V/2A fast-blow type fuse ϕ 5.2 X L20	HF003000200	For LCD/fan motor power (+24V) protection Mounted on the fuse clip 1 pc. is packed together as accessories.
	SDC p.c.b. F4	250A/4A time-lag fuse ϕ 5.2 X L20	HF0089040P0	For switching power primary circuit protection Fixed on p.c.b. by soldering
	SDC p.c.b. F5	250V/4A time-lag fuse ϕ 5.2 X L20	HF0089040P0	For switching power primary circuit protection Fixed on p.c.b. by soldering
	FLT p.c.b. F1	250V/20A time-lag fuse ϕ 6.35 X L30	HF006802000	For AC input protection Fixed on p.c.b. by soldering
	FLT p.c.b. F2	250V/20A time-lag fuse ϕ 6.35 X L30	HF006802000	For AC input protection Fixed on p.c.b. by soldering
	FLT p.c.b. F3 (FLT-T p.c.b. only)	250V/20A time-lag fuse ϕ 6.35 X L30	HF006802000	For AC input protection Fixed on p.c.b. by soldering

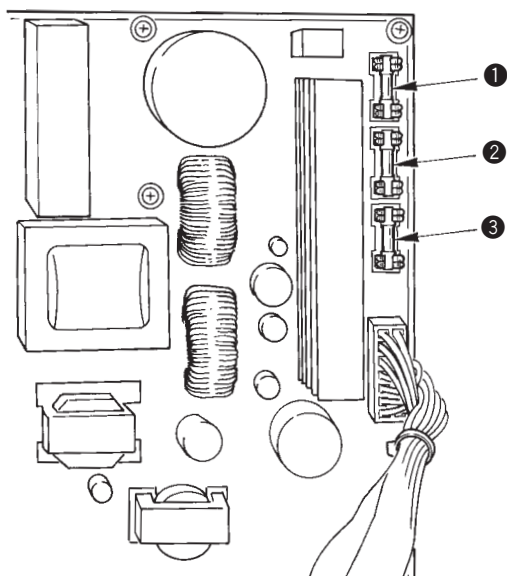

- ① For stepping motor power supply protection
5A (time-lag fuse)
- ② For solenoid and stepping motor power supply protection
3.15A (time-lag fuse)
- ③ For control power supply protection
2A (fast-blow type fuse)

13. GAUGE COMPONENTS AND OPTIONAL COMPONENTS

(1) Cloth cutting knife

⊙ : Mounted on machine △ : Accessories (FOR LBH-1790S)

No.	A : Knife size (inch)	B : Knife size (mm)	C : Mark	D : Part No.	Remarks
1	1/4	6.4	F	B2702047F00	
2	3/8	9.5	K	B2702047K00A	△
3	7/16	11.1	I	B2702047I00	
4	1/2	12.7	L	B2702047L00A	⊙
5	9/16	14.3	V	B2702047V00	
6	5/8	15.9	M	B2702047M00A	△
7	11/16	17.5	A	B2702047A00	
8	3/4	19.1	N	B2702047N00	
9	7/8	22.2	P	B2702047P00	
10	1	25.4	Q	B2702047Q00A	△
11	1-1/4	31.8	S	B2702047S00A	

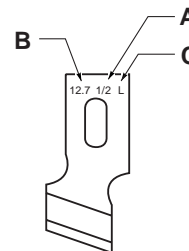

(2) Throat plate

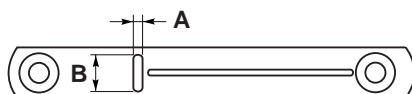

⊙ : Mounted on machine

Type	Stitch width	5 mm (AxB) (mm)	Remarks	6 mm (AxB) (mm)	Remarks
	Standard : S (Part No.)		(40004350) S5 (1.4x6.2)	⊙	(40004351) S6 (1.4x7.4)
For knits : K (Part No.)		(40004352) K5 (1.2x6.2)	⊙	(40004353) K6 (1.2x7.4)	

(3) Presser

○ : Stitch width 5 mm

⊙ : Mounted on machine △ : Accessories (For LBH-1790S)

Type	Size (A X B)	1 : (4x25) (mm)	Remarks	2 : (5x35) (mm)	Remarks	3 : (5x41) (mm)	Remarks
Standard : S (Part No.)		B1552781000A	⊙	B1552782000	△	B1552783000	
For knits : K (Part No.)		D1508771K00A		D1508772K00	⊙	D1508773K00	

○ : Stitch width 6 mm

Type	Size (A X B)	3 : (6x41) (mm)
Standard : S (Part No.)		14524409

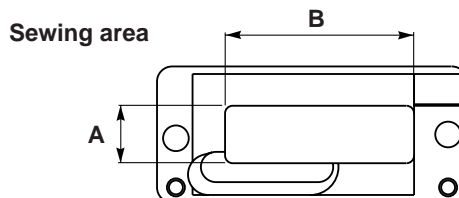

(4) Presser foot

Type	Type 1	Type 2	Type 3
Part No. of presser foot	D1511771KA0A	D1511772KA0	D1511773KA0
Standard : S	⊙	△	※
For knits : K	※	⊙	※

* Two screws, SS6060210SP are necessary for the optional presser foot.

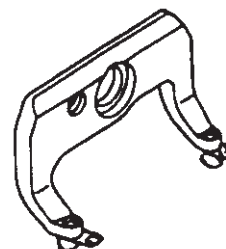

(5) Non-lubrication hook

No.	Part No.	Name of part	Q'ty	Remarks
①	40006345	RP hook (asm.)	1	Complete dry-head machine is produced by installing non-lubrication hook. (Max. sewing speed reaches 3,300 rpm.)
②	40006349	RP bobbin case	1	
③	13729603	Hook sleeve (asm.)	1	
④	SS8660612TP	Setscrew	4	

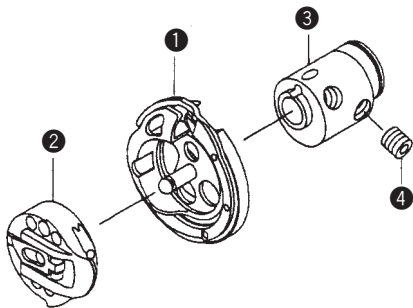

(6) Electric bobbin winder

No.	Part No.	Name of part	Q'ty	Remarks
1	G50011980A0A	Electric bobbin winder (asm.)	1	Device that can wind bobbin thread independently
2	40005405	Bobbin winder power cord (asm.)	1	
3	B32217710A0	Bobbin winder thread tension (asm.)	1	
4	SK3452000SC	Wood screw	4	

(7) 2-pedal for standing work

No.	Part No.	Name of part	Q'ty	Remarks
1	GPK510010B0	2-pedal for standing work (asm.)	1	
2	GPK570010B0	1-pedal for standing work (asm.)	1	
3	40003493	PK pedal joint cord (asm.)	1	

14. OTHERS

(1) Points of replacement for feed 70 mm and 120 mm

1) Replacement parts for feed 70 mm and 120 mm

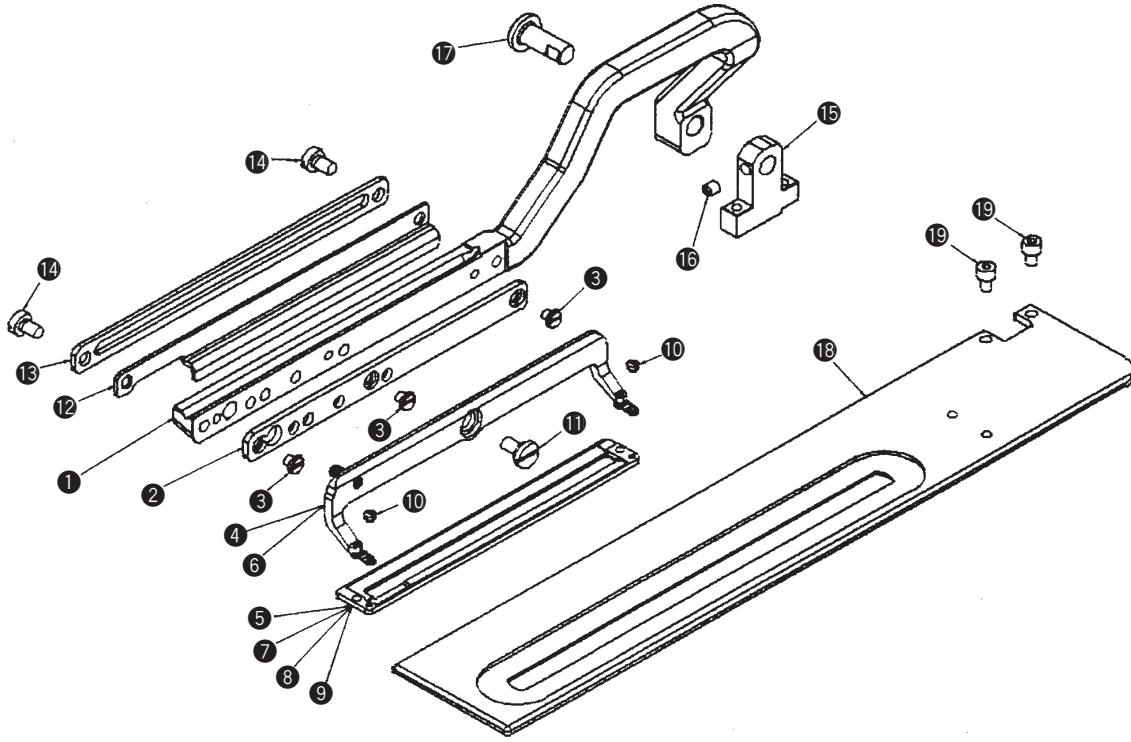

No.	Part No.	Name of part	Q'ty	Remarks
①	40006335	Presser arm 120	1	Common to 70 mm and 120 mm
②	40006340	Presser arm spacer	1	Not necessary when using 120 mm presser
③	SM6040450TP	Setscrew	3	Not necessary when using 120 mm presser
④	40008646	Presser foot 120 (asm.)	1	For feed 120 mm
⑤	40008658	Presser foot 120	1	For feed 120 mm
⑥	14523252	Presser foot 70 (asm.)	1	For feed 70 mm
⑦	14523401	Presser 70	1	For feed 70 mm (for knits)
⑧	14523708	Urethane presser 70	1	* Optional for feed 70 mm (for cloth)
⑨	14524102	Flat presser 70	1	* Optional for feed 70 mm (for heavy-weight cushion stuff)
⑩	SS6060210SP	Setscrew	2	Common to 70 mm and 120 mm
⑪	SD0790203SP	Hinge screw	-	Incorporated in machine head
⑫	40006341	Close cam 120	1	Common to 70 mm and 120 mm
⑬	40006342	Lifting plate 120	1	Common to 70 mm and 120 mm
⑭	SM6050800SP	Setscrew	2	Common to 70 mm and 120 mm
⑮	40004203	Feed base (asm.)	-	Incorporated in machine head
⑯	SM8050502TP	Setscrew	-	Incorporated in machine head
⑰	40004288	Presser arm shaft	-	Incorporated in machine head
⑱	40006339	Cloth feed plate 120	1	Common to 70 mm and 120 mm
⑲	SM6040602TP	Setscrew	-	Incorporated in machine head

2) Replacing and assembling procedure of the parts

1. Turn OFF the power switch of the sewing machine.
2. Remove the needle and the cloth cutting knife from the sewing machine.
3. Remove presser roller installing base 20. (Remove setscrews 21 as shown in the figure below.)
4. Remove presser arm 22. (Setscrew 16 as shown in the figure on the left side)
5. Remove cloth feed plate 23. (Setscrews 19 as shown in the figure on the left side)
6. Assemble presser arm spacer 2 to presser arm 120 1 with setscrews 3. (Only when using 70 mm presser)
7. Assemble presser foot 120 (asm.) 4 or presser foot 70 (asm.) 6 to presser foot 120 5, presser 70 7, urethane presser 70 8 or flat presser 70 9 with setscrews 10.
8. Assemble close cam 120 12 and lifting plate 120 13 to presser arm 120 1 with setscrews 14. The thinner part of lifting plate 120 13 comes upward.
9. Assemble presser foot 120 (asm.) 4 or presser foot 70 (asm.) 6 to presser arm 120 1 with hinge screw 11.
10. Assemble cloth feed plate 120 18 to feed base (asm.) 15 with setscrews 19.
11. Assemble presser arm 120 1 to feed base (asm.) 15 with presser arm shaft 17 and setscrew 16.
12. Assemble presser roller installing base 20 with setscrews 21.
13. Loosen setscrews 14 and adjust lifting plate 120 13 so that there is no play in the lateral direction of presser arm 120 1 when the presser is lifted.
14. Attach the needle and the cloth cutting knife.

3) Setting the memory switch

1. Turn ON the powerswitch.
2. Press M key of the panel to enter level 1 of the memory switch. (State that U** is displayed)
3. Set U14 kind of presser to 5 and set U15, Presser size width to 5 and U16 Presser size length to 70 or 120.
4. Set the knife size to use for U18, Cloth cutting knife size, and make U19, Function of plural motions of cloth cutting knife effective.
5. Press READY key to determine the contents of the change of memory switch.
6. Set the sewing length, width, etc, press the feed FORWARD/BACKWARD key and check that the needle hole does not hide under the presser.
7. Perform sewing.

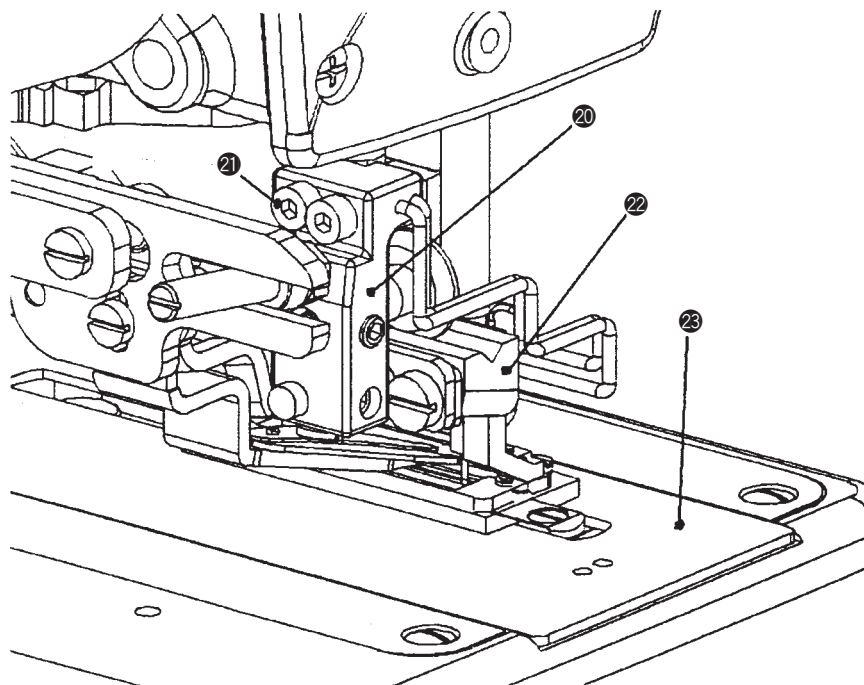

15. TROUBLES AND CORRECTIVE MEASURES

(1) With regard to sewing

Trouble	Cause (1)	Cause (2)	Checking order and adjusting procedure	Page	
1. Needle thread breakage	1-1) Attaching needle is wrong.	1)-A Direction of needle is wrong.	Attach the needle so that the indented part of the needle faces to this side as observed from the front of the sewing machine.		
		1)-B Height of needle is wrong.	Insert the needle until the top end of the shank of needle comes in contact with the upper end of the needle hole of needle bar.		
		1)-C Needle is bent.	Place the needle on the flat section of the table or the like, press the shank section with fingers and turn the needle to check the deflection of the needle tip. If the needle is deflected, replace it.		
	1-2) Threading is wrong.			Correctly thread the needle thread.	
		1-3) There are scratches on the thread path sections.	3)-A There are scratches on thread take-up spring, thread take-up lever, thread tension disk, throat plate, needle bar thread guide, etc. Or, thread path has worn out.	Correct the scratch with buff, or replace the part. Especially take care of the finish of the lower face of needle hole in the throat plate.	
			3)-B There is a scratch on the blade point of hook or periphery of hook.	Correct the scratch with buff, or replace the part.	
	1-4) Adjustment of thread tension components is wrong.	4)-A Bar-tacking thread tension is too high or too low.		Checking the balance of stitches at bar-tacking section (needle thread on the right side and bobbin thread on the wrong side), adjust the tension.	
			4)-B Thread tension at parallel is too high or too low.	Make the bobbin thread tension proper. Confirming the crest of seam at parallel section of stitches, adjust the tension. (Refer to the Instruction Manual.)	
			4)-C Tension or stroke of thread take-up spring is improper.	Standard stroke : 8 to 10 mm Tension 0.06 to 0.1N	

▶ To the next page

Trouble	Cause (1)	Cause (2)	Checking order and adjusting procedure	Page
From the previous page	1-5) Needle-to-hook timing is improper.	5)-A Height of the needle bar is improper.	Perform adjusting the timing when needle enters in the center of the throat plate of left stitch base line. At this time, clearance provided between the bottom end of needle bar and the top surface of throat plate is 12.0 mm (standard) or 11.3 mm (K) at the lowest point of the needle bar. Adjust the height using the timing gauge "1".	(See page 3.)
		5)-B Adjustment of the blade point of hook and needle is improper.	Perform adjusting timing when needle enters in the center of the throat plate . Loosen hook sleeve setscrew and adjust, using the timing gauge "2", so that the blade point of hook comes in the center of needle when needle goes up from its lower dead point. In addition, make sure that needle does not come in contact with the blade point of hook when needle throws on the right side. At this time, provide a clearance of 0.01 to 0.04 mm between the needle and the blade point of hook.	(See page 3.)

▶ To the next page

Trouble	Cause (1)	Cause (2)	Checking order and adjusting procedure	Page
From the previous page				
1-6) Thread is entangled in the hook.			Remove thread (single thread) entangled in inner hook or outer hook.	
1-7) Thread breakage due to needle heat			Decrease the number of revolution.	
1-8) Position of thread take-up thread guide (A) is improper.			Adjustment of thread take-up thread guide (A) 	
1-9) Thread breakage at the start of sewing		9)-A Tension at the start of sewing is too low.	Increase tension at the start of sewing.	
		9)-B Soft-start speed is too fast.	Delay the soft-start speed.	
		9)-C Number of stitches at the start of sewing is too many.	Decrease the number of stitches at the start of sewing.	
		9)-D Thread breakage due to piercing of needle	Enter the start of sewing pitch.	
1-10) Thread breakage at the end of sewing		10)-A Number of stitches of tie stitching is too many.	Decrease the number of stitches of tie stitching.	
		10)-B Width of tie stitching is too narrow.	Widen the width of tie stitching.	
		10)-C Number of stitches of radial shape at the end of sewing is too many.	Increase the bar-tacking pitch.	
1-11) Partial catch of thread by hook due to return of twist (Single yarn catch)			Increase the stroke of thread take-up spring, decrease the tension and make the loop smaller. Advance the timing of catching thread at the blade point of hook, and make the loop smaller to stabilize catching thread.	
		11)-A Sewing speed is fast and thread is untwined when tetron thread is used.	Decrease the number of rotation to 3,300 rpm or less.	
1-12) Thread breaks when purl stitching is performed with knit materials.		12)-A) Number of rotation is too fast.	Decrease the number of rotation to 3,300 rpm or less.	
		12)-B) Cloth flops.	Perform basting.	
		12)-C) Thread is untwined.		

Trouble	Cause (1)	Cause (2)	Checking order and adjusting procedure	Page
2. Stitch skipping	2-1) Attaching needle is wrong.	1)-A Direction of needle is wrong.	Attach the needle so that the indented part of the needle faces to this side as observed from the front of the sewing machine.	
		1)-B Height of needle is wrong.	Insert the needle until the top end of the shank of needle comes in contact with the upper end of the needle hole of needle bar.	
		1)-C Needle is bent.	Place the needle on the flat section of the table or the like, press the shank section with fingers and turn the needle to check the deflection of the needle tip. If the needle is deflected, replace it.	
		1)-D Needle tip is blunt.	Replace the needle.	
		1)-E Needle is too thin.	Use a proper needle for the fabric or thread.	
	2-2) Needle-to-hook timing is improper.	2)-A Height of the needle bar is improper.	Perform adjusting the timing when needle enters in the center of the throat plate of left stitch base line. At this time, clearance provided between the bottom end of needle bar and the top surface of throat plate is 12.0 mm (standard) or 11.3 mm (K) at the lowest point of the needle bar. Adjust the height using the timing gauge "1".	
		2)-B Adjustment of the blade point of hook and the needle is improper.	Perform adjusting the timing when needle enters in the center of the throat plate. Loosen hook sleeve setscrew and adjust, using the timing gauge "2" so that the blade point of hook comes in the center of the needle when needle goes up from its lower dead point. Besides, check that needle does not come in contact with the blade point of hook when needle rocks to the right side. At this time, provide a clearance of 0.01 to 0.04 mm between the needle and the blade point of hook.	

▶ To the next page

Trouble	Cause (1)	Cause (2)	Checking order and adjusting procedure	Page
From the previous page				
2-3) Blade point of hook is blunt.	3-A) The blade point comes in contact with the needle.	Correct the blade point or replace the hook, and adjust the hook timing according to item 2)-B.		
2-4) State of pressing fabric is improper.	4)-A) Presser is inclined, or does not move smoothly. (Presser presses fabric while it is inclined.)	Replace hinge screw for attaching the work clamp check holder.		
	4)-B) Presser pressure is too low.	Increase the presser pressure.		
	4)-C) Presser is too large in terms of the button hole.	Use the presser suitable for the button hole.		
	4)-D) Fabric flops since overlapped section is pressed.	Use the presser for overlapped section. Or, decrease the number of revolution.		
	4)-E) Fabric flops since material is of thin knit or jersey.	Use the presser for knit and jersey. Adjust the hook timing to K type timing.		
2-5) Adjustment of thread tension is improper.	5)-A) Tension at the parallel section is too high.	Adjust the needle thread tension to proper one. (Decrease the tension.)		
	5)-B) Tension or stroke of thread take-up spring is improper.	Standard stroke : 8 to 10 mm Tension : 0.06 to 0.1N.		
2-6) Play of needle bar		Decrease the play of needle bar. Or, replace the needle bar.		

▶ To the next page

Trouble	Cause (1)	Cause (2)	Checking order and adjusting procedure	Page
---------	-----------	-----------	--	------

From the previous page

	<p>2-7) Change of needle thread loop</p>	<p>7)-A Loop of spun thread or cotton thread falls at the speed of 3,300 rpm or more.</p> <p>7)-B Loop is hard to be made with fabric related to knit.</p>	<p>Decrease the number of revolution.</p> <p>Raise the lowest point of needle bar by 0.6 mm, and re-adjust needle-to-hook timing.</p> <p>It is effective to slightly lower needle bar than the case of standard timing and to delay the hook timing.</p> <p> 1 mm Adjust so that the blade point of hook comes to the position of approximately 1 mm from the top end of the needle eyelet.</p>	
<p>3. Needle thread slip-off</p>	<p>3-1) Installation or timing of needle thread trimmer is improper.</p>	<p>1)-A Opening timing of trimmer is too early.</p> <p>1)-B Thread grasping force of the trimmer is too weak.</p> <p>1)-C Closing amount of the trimmer is too small.</p>	<p>Adjust the operating timing of needle thread trimmer so that the trimmer gradually opens at the position of approximately 1 to 2 mm from the start of sewing.</p> <p>Correct the thread presser spring so that the spring comes in contact with the whole of the blade of thread trimmer.</p> <p>When there is a mismatch of the trimmer, replace it.</p>	
	<p>3-2) Finish of thread presser spring is improper.</p>	<p>2)-A Thread presser spring cuts needle thread.</p>	<p>Finish with buff the contact face of the thread presser spring with needle thread.</p>	
	<p>3-3) Setting of tension at the start of sewing is improper.</p>	<p>3)-A Tension is too high.</p>	<p>Adjust the tension so that whip stitching is performed at the start of sewing.</p>	

▶ To the next page

Trouble	Cause (1)	Cause (2)	Checking order and adjusting procedure	Page
From the previous page	3-4) Needle and bobbin thread are not knotted at the start of sewing.	4)-A Tie stitching pitch is "0". 4)-B Tie stitching width is too wide.	Enter tie stitching pitch. Make tie stitching width narrow.	
	3-5) Thread slip-off due to hangnail of thread		Increase number of stitches at the start of sewing. Data No.S26	
	3-6) Number of revolution at the start of sewing is too high. (In case of tetron thread)		Refer to 1. Needle thread breakage of Trouble.	
			Refer to the memory switch, and decrease the number of revolution of the soft-start.	
	4-1) Thread tension is improper.	1)-A Setting of needle thread tension (at the end of sewing) is improper. 1)-B Setting of needle thread tension (at the time of thread trimming) is improper.	Change the data of the memory switch. Change the data of the memory switch.	
	4-2) Needle thread trimmer is positioned too high.		Lower the trimmer to such an extent that it does not come in contact with the presser.	
4-3) Set value of tie stitching on the panel is improper.	3)-A Width of tie stitching is too narrow. 3)-B Number of stitches of tie stitching is too many.	Widen the width of tie stitching. Decrease the number of stitches of tie stitching.		

Trouble	Cause (1)	Cause (2)	Checking order and adjusting procedure	Page
5. Crest of seam wobbles.	5-1) Wobbling at the start of sewing	1)-A Tension at the start of sewing is too low.	Increase the tension at the start of sewing.	
		1)-B Tension at the parallel section is too low.	Increase the tension at the parallel section.	
		1)-C Stroke of the thread take-up spring is too large.	Decrease the stroke of the thread take-up spring and increase the spring pressure.	
		1)-D Position of the needle thread trimmer is too high.	Lower the needle thread trimmer to such an extent that it does not come in contact with the work clamp check holder or the presser foot.	
		2)-A Tension at the parallel section is too low.	Increase the tension at the parallel section.	
6. Thread frays.	5-2) Wobbling at the parallel section	2)-B Tension of the thread take-up spring is too low and the stroke is insufficient.	Increase the tension of the thread take-up spring and increase the stroke.	
		1)-A Bar-tacking thread tension is too low.	Increase the bar-tacking thread tension.	
	6-1) Needle thread frays when pulling it at the end of sewing.	1)-B Bobbin thread tension is too low.	Increase the bobbin thread tension.	
6-2) Bobbin thread frays when pulling it at the end of sewing.		2)-A Bar-tacking thread tension is too high.	Decrease the bar-tacking thread tension.	
		2)-B Bobbin thread tension is too high.	Decrease the bobbin thread tension.	
6-3) Set value of tie stitching on the panel is improper.		3)-A Width of tie stitching is too wide.	Narrow the width of tie stitching.	
		3)-B Number of stitches of tie stitching is too small.	Increase the number of stitches of tie stitching.	

Trouble	Cause (1)	Cause (2)	Checking order and adjusting procedure	Page
7. Needle breaks.	7-1) Other parts come in contact with needle.	1)-A Blade point of the hook comes in contact with needle.	Refer to the item (2) of STANDARD ADJUSTMENT. (Needle-to-hook timing)	
		1)-B Needle is not in the center of needle hole in the throat plate.	Refer to (1) Adjusting needle rock origin of 4. ADJUSTMENT OF RESPECTIVE SENSORS.	
		1)-C Needle is bent.	Replace the needle.	
		1)-D Needle thread trimmer comes in contact with needle.	Refer to the item of STANDARD ADJUSTMENT. ((8) Adjusting the needle thread trimmer)	
	7-2) Basting thread tension is too high.		Decrease the basting thread tension, or decrease the pitch.	
8. Sewing is occasionally disordered.	8-1) Bobbin thread tension is improper.		Re-set the bobbin thread tension to 0.15N (puri stitching).	
9. The stitches protrude at 2nd bartacking of radial type shape or round type shape.	9-1) Position of the start of sewing is near to the most retreated position of the feed.		Increase the set value of the position of the start of sewing.	

(2) With regard to mechanical components

Trouble	Cause (1)	Cause (2)	Checking order and adjusting procedure	Page
1. Height of needle is improper when the sewing machine has stopped.	1-1) Main shaft stop position is improper.	1)-A Position of the coupling and the flat section (main shaft) is improper.	Check the setscrew in the coupling referring to 5.- (1) Disassembling/assembling the main shaft.	
2. Cloth cutting knife fails to drop.		Cord of knife driving solenoid is disconnected.	Connect the cord.	
3. Cloth cutting knife fails to cut.	3-1) Stroke of the cloth cutting knife is improper.	1)-A Installing position of knife driving solenoid is improper.	Refer to the item (5) of STANDARD ADJUSTMENT.	
		1)-B Installing position of the cloth cutting knife is improper.	Slightly lower the height of cloth cutting knife.	
	3-2) Sharpness of the cloth cutting knife is dull.	2)-A Blade of the knife is broken.	Replace the knife with a new one.	
		2)-B A knife other than the genuine one is used.	Replace the knife with a genuine one.	
4. Cloth cutting knife fails to return. (Refer to 52. error E999.)	4-1) Skew in the cloth cutting knife drive section	1)-A Adjusting the play of knife bar is improper.	Adjust the play with the knife bar presser.	
		1)-B Cloth cutting knife interferes with needle bar.	Refer to the item (5) of STANDARD ADJUSTMENT.	
		1)-C Skew due to cutting waste or dust in drive section	Clean often the drive section.	
	4-2) The cloth cutting knife bites in cloth and does not return.	2)-A Sharpness of the knife is dull.	Replace the knife with a new one.	
		2)-B Setting of knife groove width is excessively large for the floppy materials.	Replace the presser or make the setting of knife groove width as small as possible.	
		2)-C Installing position of knife driving solenoid is improper.	Refer to the item (5) of STANDARD ADJUSTMENT.	
		2)-D The cloth cutting knife bites in soft material and does not return.	Increase K20 cloth cutting knife return power.	
5. Presser fails to work. (Presser fails to go up.)	5-1) Cord of the presser lifter motor is disconnected.		Connect the cord.	

(3) With regard to electrical components

Trouble	Cause (1)	Cause (2)	Checking order and adjusting procedure	Page	
1. Display fails to appear on the operation panel.	1-1) DC power is not supplied.	1)-A AC power is not supplied.	Check whether the power comes to the power switch.		
		1)-B Power is not supplied to FLT p.c.b.	Check whether AC voltage comes between 4 and 5 pins of CN1 of FLT p.c.b. When it does not come, check the connection of power switch.		
		1)-C Power is not supplied to SDC p.c.b.	Check whether DC 280V comes between 1 and 3 pins of CN17 of SDC p.c.b. When it does not come, check the connection with FLT p.c.b. If the connection has no problem, replace FLT p.c.b.		
		1)-D Power is not supplied to MAIN p.c.b.	Check that DC5V comes between 7 and 14 pins of CN31 and DC24V between 5 and 12 pins. If they do not come, check the connection with SDC p.c.b. If the connection has no problem, replace SDC p.c.b.		
		1)-E Power is not supplied to operation panel.	Check whether cable from operation panel is connected to CN34 of MAIN p.c.b. If the connection has no problem, replace MAIN p.c.b.		
					Check whether all SW2 of PANEL p.c.b. are OFF.
					Turn ON the power and press panel key. If there is no buzzer sound, PANEL p.c.b. is failed.
					Turn ON the power and press panel key. If there is buzzer sound, PANEL p.c.b. is normal. Failure of LCD
	1-2) Micro computer of operation panel fails to work.				
	1-3) Failure of LCD Or, breakage of wire				

Trouble	Cause (1)	Cause (2)	Checking order and adjusting procedure	Page
2. Back-light of operation panel fails to light up.	2-1) Micro computer of operation panel fails to work.	1)-A DIP switch setting of PANEL p.c.b. is improper. 1)-B Failure of PANEL p.c.b.	Check whether all of SW2 of PANEL p.c.b. are OFF. Turn ON the power and press panel key. If there is no buzzer sound, PANEL p.c.b. fails to work.	
3. Key of operation panel fails to work.	3-1) Signal is not transmitted.	1)-A Failure of key. 1)-B Panel sheet is not connected to PANEL p.c.b.	When the specified key fails to work, panel sheet failed. Check whether CN105 of PANEL p.c.b. is connected.	
4. Error E001 EEPROM initialization error repeatedly occurs.	4-1) EEPROM fails to read or write.	1)-A Failure of EEPROM	Replace EEPROM.	
5. Error E007 Main shaft motor lock error repeatedly occurs.	5-1) Motor fails to normally rotate. 5-2) Mechanical section is locked.	1)-A Connector of motor is disconnected or wire is broken.	Check the connection of CN16 of SDC p.c.b. and breakage of wire. Check the mechanical section whether there is any place to which heavy load is applied or any screw is loosened.	
6. Error E018 EEPROM type error repeatedly occurs.	6-1) EEPROM fails to read or write.	1)-A EEPROM type setting is improper. 1)-B Failure of EEPROM	Check jumper for EEPROM type setting. Refer to "Change of data ROM". Replace EEPROM.	
7. Error E025 Needle thread trimmer motor step-out detection error repeatedly occurs.	7-1) Sensor fails to detect the edge of cam at proper timing.	1)-A Abnormality such as heavy load applied to mechanical section 1)-B Failure of sensor or wire is broken.	Check the mechanical section whether there is any place to which heavy load is applied or any screw is loosened. Refer to (8)-3) Needle thread trimming adjustment mode". Check that lamp of sensor is turned ON/OFF when making metallic plate near to or separate from sensor surface. If it is not turned ON/OFF, sensor fails to work or wire at connector section is broken.	

▶ To the next page

Trouble	Cause (1)	Cause (2)	Checking order and adjusting procedure	Page
From the previous page	7-2) Sensor signal is not transmitted to microcomputer of MAIN p.c.b.	2)-A INT p.c.b. connector is disconnected.	Check the connection of CN77 of INT p.c.b.	
		2)-B Breaking of wire of MAIN-INT cord B (asm.)	Check whether MAIN-INT cord B (asm.) is disconnected. Refer to "Connection circuit diagram between head and control box".	
		2)-C Failure of MAIN p.c.b.	When the aforementioned check is OK, failure of MAIN p.c.b. is proved.	
	7-3) Motor fails to normally rotate.	3)-A INT p.c.b. connector is disconnected.	Check the connection of CN65 of INT p.c.b.	
		3)-B Breaking of wire of MAIN-INT cord B (asm.)	Check whether MAIN-INT cord B (asm.) is disconnected. Refer to "Connection circuit diagram between head and control box".	
		3)-C Failure of motor	Remove CN65 of INT p.c.b. and check the cam by turning by hand. When there is feeling of scratching there, failure of motor is proved.	
		3)-D Breaking of lead wire of motor	Remove CN65 of INT p.c.b. and check the resistance value between respective pins. Refer to "Stepping motor/solenoid circuit diagram".	
		3)-E Failure of MAIN p.c.b.	When the aforementioned check is OK, failure of MAIN p.c.b. is proved.	
	8. Error E026 Bobbin thread trimming motor step-out detection error repeatedly occurs.	8-1) Sensor fails to detect the edge of cam at correct timing.	1)-A There is abnormality such as heavy load at mechanical section or the like. 1)-B Failure of sensor or breaking of wire	Check mechanical section whether there is any place to which heavy load is applied or screws are loosened. Refer to (9) Adjusting the bobbin thread trimmer. Make sure that sensor lamp is turned ON/OFF when making metallic plate come near or separate from the sensor plane. When it is not turned ON/OFF, failure of the sensor or breaking of wire at connector section is proved.

▶ To the next page

Trouble	Cause (1)	Cause (2)	Checking order and adjusting procedure	Page	
From the previous page	8-2) Sensor signal is not transmitted to micro computer of MAIN p.c.b.	2)-A INT p.c.b. connector is disconnected.	Check the connection of CN72 of INT p.c.b.		
		2)-B Breaking of wire of MAIN-INT cord B (asm.)	Check whether breaking of wire is in MAIN-INT cord B (asm.). Refer to "Connection circuit diagram between control box and head".		
		2)-C Failure of MAIN p.c.b.	When the aforementioned check is OK, failure of MAIN p.c.b. is proved.		
	8-3) Motor fails to normally rotate.	3)-A INT p.c.b. connector is disconnected.	Check the connection of CN69 of INT p.c.b.		
		3)-B Breaking of wire of MAIN-INT cord B (asm.)	Check whether breaking of wire is in MAIN-INT cord B (asm.). Refer to "Connection circuit diagram between control box and head".		
		3)-C Failure of motor	Remove CN69 of INT p.c.b. and check the cam by turning by hand. When there is feeling of scratching there, failure of motor is proved.		
		3)-D Breaking of wire of motor lead wire	Remove CN69 of INT p.c.b. and check the resistance value between respective pins. Refer to "Stepping motor/solenoid circuit diagram".		
		3)-E Failure of MAIN p.c.b.	When the aforementioned check is OK, failure of MAIN p.c.b. is proved.		
	9. Error E030 Needle bar UP position miss error repeatedly occurs.	9-1) Main shaft motor fails to normally rotate.	1)-A There is abnormality such as heavy load to main shaft, large variation of load, etc.	Turn main shaft by hand and check whether there is any place to which heavy load is applied.	
		1)-B Main shaft motor connector is disconnected or wire is broken.	Check the connection of connectors CN14 and CN16 of SDC p.c.b.		
1)-C Failure of main shaft motor or encoder		Check whether respective signals come to CN14 of SDC p.c.b. When encoder fails to work, replace it together with motor. In addition, remove CN16 and check the resistance value between respective pins. Refer to "Servo motor circuit diagram".			
1)-D Failure of SDC p.c.b.		When the aforementioned check is OK, failure of SDC p.c.b. is proved.			

▶ To the next page

Trouble	Cause (1)	Cause (2)	Checking order and adjusting procedure	Page
From the previous page				
10. Error E050 E050 occurs while stop switch is not pressed.	9-2) Needle up motion command from MAIN p.c.b. is not transmitted to SDC p.c.b.	2)-A Breaking of wire of SDC-MAIN cord S (asm.)	Check whether breaking of wire is in SDC-MAIN cord S (asm.). Refer to "Connection circuit diagram between control box and head".	
	9-3) Needle up motion command is not transmitted from MAIN p.c.b.	3)-A Failure of MAIN p.c.b.	When the aforementioned check is OK, failure of MAIN p.c.b. is proved.	
	10-1) Signal is not properly transmitted.	1)-A Connection with relay cord is disconnected. Or, connector of INT p.c.b. is disconnected.	Check the wiring inside machine head. Check whether relay cord CN96 of the stop switch is disconnected. Or, check the connection of CN75 of INT p.c.b.	
		1)-B Breaking of wire of MAIN-INT cord B (asm.)	Check whether breaking of wire is in MAIN-INT cord B (asm.). Refer to "Connection circuit diagram between control box and head".	
		1)-C Failure of the stop switch	Check whether terminal is disconnected or the switch is turned ON/OFF.	
	10-2) Failure of MAIN p.c.b.		When the aforementioned check is OK, failure of MAIN p.c.b. is proved.	
11. Error E052 Thread breakage detection error repeatedly occurs.	11-1) Signal is not properly transmitted.	1)-A Connector of INT p.c.b. is disconnected.	Check the connection of CN76 of INT p.c.b.	
		1)-B Breaking of wire of MAIN-INT cord B (asm.)	Check whether breaking of wire is in MAIN-INT cord B (asm.). Refer to "Connection circuit diagram between control box and head".	
		1)-C Thread breakage detecting plate comes in contact with any metallic part other than thread take-up spring.	Check whether thread breakage detecting plate comes in contact with metallic part at thread tension section.	
12. Error E061 Memory switch data error repeatedly occurs.	11-2) Failure of MAIN p.c.b. or INT p.c.b.		When the aforementioned check is OK, failure of MAIN p.c.b. is proved.	
	12-1) Failure of EEPROM or MAIN p.c.b.		Replace EEPROM. If it is NG, failure of MAIN p.c.b. is proved.	

Trouble	Cause (1)	Cause (2)	Checking order and adjusting procedure	Page
13. Error E062 Sewing data error repeatedly occurs.	13-1) Failure of EEPROM or MAIN p.c.b.		Replace EEPROM. If it is NG, failure of MAIN p.c.b. is proved.	
14. Error E099 Interference error of knife down command with thread trimming motion occurs.	14-1) Knife down command inserting position is not proper at external data input and it interferes with thread trimming motion.		Check the inserting position of knife down command.	
15. Error E302 Head tilting error repeatedly occurs.	15-1) Signal is not properly transmitted.	1)-A Connection with relay cord is disconnected.	Check the wiring of the rear side of machine head. Check whether relay cord CN171 of safety switch is disconnected. In addition, check the connection of CN71 of INT p.c.b.	
		1)-B Connector of MAIN-INT cord B (asm.) is disconnected.	Check connection or breaking of wire of MAIN-INT cord B (asm.). Or, check the connection of CN71 of INT p.c.b.	
		1)-C Failure of safety switch	Check whether wire of terminal is broken or switch is turned ON/OFF.	
	15-2) Failure of MAIN p.c.b.		When the aforementioned check is OK, failure of MAIN p.c.b. is proved.	
16. Error E303 Main shaft motor Z phase sensor error repeatedly occurs.	16-1) Encoder signal is not properly transmitted.	1)-A Breaking of wire or failure of encoder	Check whether respective signals come at CN14 of SDC p.c.b. In case of failure of the encoder, replace it together with motor. Refer to "Servo motor circuit diagram".	
	16-2) Failure of SDC p.c.b.		When the aforementioned check is OK, failure of SDC p.c.b. is proved.	
17. Error E304 Cloth cutting knife sensor error repeatedly occurs. Sensor is not turned OFF when knife comes down.	17-1) Cable connection is defective.	1)-A Connector of INT p.c.b. is disconnected.	Check the connection of CN81 and CN67 of INT p.c.b.	
		1)-B Breaking of wire of MAIN-INT cord A (asm.)	Check whether wire of MAIN-INT cord A (asm.) is broken. Refer to "Connection circuit diagram between control box and head".	
	17-2) Failure of MAIN p.c.b.		When the aforementioned check is OK, failure of MAIN p.c.b. is proved.	
	17-3) Cloth cutting knife solenoid is broken.		Replace the cloth cutting knife solenoid.	

Trouble	Cause (1)	Cause (2)	Checking order and adjusting procedure	Page
18. Error E486 Eyelet knife length error occurs.	18-1) As a result of operation, eyelet shape is not formed.	1)-A Set values of width (S16) of eyelet section and knife length (S17) are improper.	Check whether S16<S17 is performed. Refer to "9. EXPLANATION OF SHAPE".	
19. Error E487 Eyelet shape length error occurs.	19-1) As a result of operation, eyelet shape is not formed.	1)-A Set values of knife groove width, left (S04), overedging width, left (S05), eyelet shape length (S14) and eyelet length (S17) are improper.	Check whether 0<S14-S05-S04<S17 is performed. Refer to "EXPLANATION OF SHAPE".	
20. Error E488 Flow bar-tacking compensation error occurs.	20-1) As a result of operation, flow bar-tacking is not formed.	1)-A Set values of 2nd bar-tacking length (S08) and flow bar-tacking compensation, left (S12) are improper.	Check whether S08>S12X1.732 is performed. Refer to "EXPLANATION OF SHAPE".	
21. Error E489 Knife size error occurs.	21-1) Knife size is larger than cloth cutting length at the time of plural motions of knife.	1)-A Set values of knife size (U18) and cloth cutting length (S02) are improper.	Check whether S02 ≥ U18 is performed.	
22. Error E492 Basting presser size error occurs.	22-1) Stitching data has exceeded presser size (width direction) when basting more than two cycles.	1)-A Set values of basting needle entry compensation, left and right (S40) and basting position compensation, left (S41) or basting position compensation, right (S42) are improper.	The position where S41 is added to the center (calculated from S04 and S05) of left overedging becomes the center of left side of basting. Making it the center, basting is performed at the interval of S40. In case of 3 cycles of basting, 2nd cycle comes to this center. Check that the center does not exceed the left side of presser size. (Presser size/2 ≥ S04+(S05/2)+S41+(S40X(S34-1)/2) should be performed. In addition, the position where S42 is added to the center (calculated from S03, S05 and S06) of right overedging becomes the center of right side of basting. Making it the center, basting is performed at the interval of S40. Check that the center does not exceed the right side of presser size. (Presser size/2 ≥ S03+(S05X06/2)+S42+(S40X(S34-1)/2) should be performed.	
23. Error E493 Presser size error of tie stitching at sewing end occurs.	23-1) Stitching data of tie stitching at sewing end has exceeded presser size (width direction).	1)-A Set values of tie stitching width at sewing end (S67) and crosswise compensation of tie stitching at sewing end (S70) are improper.	Check following. • (Presser size/2) ≥ S04+(S05/2)-S70+(S67/2) ← Limitation of left side of presser • (Presser size/2) ≥ S03+(S05/2)-S70+(S67/2) ← Limitation of right side of presser	
24. Error E494 Presser size error of tie stitching at sewing start occurs.	24-1) Stitching data of tie stitching at sewing start has exceeded presser size (width direction).	1)-A Set values of tie stitching width at sewing start (S64) and crosswise compensation of tie stitching at sewing start (S66) are improper.	Check following • (Presser size/2) ≥ S04+(S05/2)-S66+(S64/2) ← Limitation of left side of presser • (Presser size/2) ≥ S03+(S05/2)-S66+(S64/2) ← Limitation of right side of presser	

Trouble	Cause (1)	Cause (2)	Checking order and adjusting procedure	Page
25. Error E495 Presser size error (width direction, right) occurs.	25-1) Stitching data has exceeded presser size (right side).	1)-A Set values of knife groove width, right (S03) or overredging width, left (S05) and ratio of left and right shapes (S06) are improper.	Check whether needle entry position does not exceed right side of the presser size according to respective set values.	
26. Error E496 Presser size error (width direction, left) occurs.	26-1) Stitching data has exceeded presser size (left side).	1)-A Set value of knife groove width, left (S04) or overredging width, left (S05) is improper.	Check whether needle entry position does not exceed left side of the presser size according to respective set values.	
27. Error E497 Presser size error (length direction, front) occurs.	27-1) Stitching data has exceeded presser size (front side).	1)-A Set value of jump feed between patterns at the time of continuous stitching is improper.	Check whether any pattern after second ones does not exceed front side of the presser size by jump feed at the time of continuous stitching.	
28. Error E498 Presser size error (length direction, left and right) occurs.	28-1) Stitching data has exceeded presser size (width direction).	1)-A Set values of knife groove width, (S03, S04) or overredging width, left (S05) and ration of left/right shape (S06) are improper.	Check whether needle entry position does not exceed right or left side of the presser size according to respective set values.	
29. Error E499 Presser size error (width direction, rear) occurs.	29-1) Stitching data has exceeded presser size (rear side).	1)-A Set values of cloth cutting length (S02), 2nd bar-tacking length (S08), 1st bar-tacking length (S09), 1st clearance (S22), 2nd clearance (S23), etc. are improper.	Check whether needle entry position does not exceed the presser size length according to respective set values.	
30. Error E703 Panel machine type error occurs.	30-1) Machine type code is not properly communicated from MAIN p.c.b. to panel.	1)-A Failure of MAIN p.c.b. or PANEL p.c.b.	Replace OPERATION panel or MAIN p.c.b.	
31. Error E704 System version error occurs.	31-1) Software versions of MAIN p.c.b., SDC p.c.b. and operation panel do not agree with each other.		Check the versions of respective p.c.b. displayed when power is turned ON. (Version is displayed while pressing MODE key when power is turned ON.) Display is shown from the top in the order of PANEL, MAIN and SDC by R-V-L. (Ex : 01-02-01) Check these Rs (Revision) agree with each other.	
32. Error E730 Main shaft motor encoder error occurs.	32-1) Encoder signal is not properly transmitted.	1)-A Breaking of wire or failure of encoder	Check whether respective signal come at CN14 of SDC p.c.b. In case of failure of encoder, replace the encoder together with motor. Refer to "Servo motor circuit diagram".	
	32-2) Failure of SDC p.c.b.		When the aforementioned check is OK, failure of SDC p.c.b. is proved.	

Trouble	Cause (1)	Cause (2)	Checking order and adjusting procedure	Page
33. Error E731 Main shaft motor hole sensor error occurs.	33-1) Encoder signal is not properly transmitted.	1)-A Encoder connector is disconnected.	Check whether connection of CN14 of SDC p.c.b is proper and breaking of wire occurs.	
		1)-B Failure of encoder	Check whether respective signals come at CN14 of SDC p.c.b. In case of failure of encoder, replace it together with motor. Refer to "Servo motor circuit diagram".	
	33-2) Failure of SDC p.c.b.		When the aforementioned check is OK, failure of SDC p.c.b. is proved.	
34. Error E733 Main shaft motor reverse rotation error occurs.	34-1) Motor fails to normally rotate.	1)-A Defective wiring or breakage of wire of motor	Check whether wiring of CN16 of SDC p.c.b. is proper or breaking of wire does not occur. Refer to "Servo motor circuit diagram".	
	34-2) Encoder signal is not properly transmitted.	2)-A Breaking of wire or failure of encoder	Check whether respective signals come at CN14 of SDC p.c.b. In case of failure of encoder, replace it together with motor. Refer to "Servo motor circuit diagram".	
	34-3) Failure of SDC p.c.b.		When the aforementioned check is OK, failure of SDC p.c.b. is proved.	
35. Error E802 Power instantaneous cut error repeatedly occurs.	35-1) A C i n p u t p o w e r instantaneously dropped.	1)-A Variation or drop of AC input power line	Check AC input power line.	
		1)-B Defective contact between power plug, power switch and FLT p.c.b.	Check whether there is any defective contact at respective sections.	
	35-2) Failure of SDC p.c.b.		When the aforementioned check is OK, failure of SDC p.c.b. is proved.	
36. Error E811 Overvoltage error repeatedly occurs.	36-1) AC input power is too high. (280V or more)	1)-A Variation or up of AC input power line	Check AC input power line.	
		1)-B Voltage setting jumper of FLT p.c.b. is improper in case of 3-phase.	Check the voltage setting (100V or 200V type) of FLT p.c.b.	
	36-2) Failure of SDC p.c.b.		When the aforementioned check is OK, failure of SDC p.c.b. is proved.	

Trouble	Cause (1)	Cause (2)	Checking order and adjusting procedure	Page
37. Error E813 Low voltage error repeatedly occurs.	37-1) AC input power is too low. (150V or less)	1)-A Variation or drop of AC input power line	Check AC input power line.	
		1)-B Voltage setting jumper of FLT p.c.b. is improper in case of 3-phase.	Check voltage setting (100V or 200V type) of FLT p.c.b.	
	37-2) Failure of SDC p.c.b.		When the aforementioned check is OK, failure of SDC p.c.b. is proved.	
38. Error E901 Main motor IPM error repeatedly occurs.	38-1) Main shaft motor drive IPM detected an error.	1)-A Heat of IPM is large.	Check whether cooling of control box is performed. Check whether inlet port is clogged, fan is defective, or the like.	
		1)-B Failure of main shaft motor	Remove CN16 of SDC p.c.b. and check resistance value between respective pins. Refer to "Servo motor circuit diagram".	
	38-2) Failure of SDC p.c.b.		When the aforementioned check is OK, failure of SDC p.c.b. is proved.	
39. Error E903 Stepping motor power error occurs.	39-1) +48V of SDC p.c.b. fluctuates more than $\pm 15\%$.	1)-A Fuse F1 or F4 of SDC p.c.b. has blown.	Check the fuse.	
		1)-B Failure of MAIN p.c.b. or SDC p.c.b.	Replace MAIN p.c.b. or SDC p.c.b.	
40. Error E904 Solenoid power error occurs.	40-1) +33V of SDC p.c.b. fluctuates more than $\pm 15\%$.	1)-A Fuse F2 or F5 of SDC p.c.b. has blown.	Check the fuse.	
		1)-B Failure of MAIN p.c.b. or SDC p.c.b.	Replace MAIN p.c.b. or SDC p.c.b.	
41. Error E905 Heat sink temperature error of SDC p.c.b. repeatedly occurs.	41-1) Heat sink temperature of SDC p.c.b. has become more than 85 C.	1)-A Cooling cannot be performed.	Check whether cooling of control box is performed. Check whether inlet port is clogged, fan is defective, or the like.	
	41-2) Failure of SDC p.c.b.		When the aforementioned check is OK failure of SDC p.c.b. is proved.	

Trouble	Cause (1)	Cause (2)	Checking order and adjusting procedure	Page	
42. Error E907 Needle rock motor origin retrieval error repeatedly occurs.	42-1) Sensor cannot detect motor lever (link).	1)-A There is abnormality such as heavy load at mechanical section or the like.	Check mechanical section whether there is any special place to which heavy load is applied, any loose screw, or the like.		
		1)-B Failure or breaking of wire of sensor	Check that sensor lamp is turned ON/OFF when making metallic plate approach or separate from the sensor plane. If it is not turned ON/OFF, failure of sensor or breaking of wire at sensor section is proved.		
		42-2) Sensor signal is not transmitted to micro computer of MAIN p.c.b.	2)-A Connector of INT p.c.b. is disconnected.	Check the connection of CN74 of INT p.c.b.	
			2)-B Breaking of wire of MAIN-INT cord B (asm.)	Check whether breaking of wire is in MAIN-INT cord B (asm.). Refer to "Connection circuit diagram between control box and head".	
			2)-C Failure of MAIN p.c.b.	When the aforementioned check is OK, failure of MAIN p.c.b. is proved.	
		42-3) Motor fails to normally rotate.	3)-A Connector of INT p.c.b. is disconnected.	Check the connection of CN82 of INT p.c.b.	
			3)-B Connector of MAIN-INT cord A (asm.) is disconnected or breaking of wire.	Check whether MAIN-INT cord A (asm.) is connected and breaking of wire is in it.	
			3)-C Failure of motor	Remove CN82 of INT p.c.b. and check by moving needle bar to the left and right by hand. If there is feeling of scratching, failure of motor is proved.	
			3)-D Breaking of wire of motor lead wire	Remove CN82 of INT p.c.b. and check the resistance value between respective pins. Refer to "Stepping motor/solenoid circuit diagram".	
			3)-E Failure of MAIN p.c.b.	When the aforementioned check is OK, failure of motor is proved.	

Trouble	Cause (1)	Cause (2)	Checking order and adjusting procedure	Page
43. Error E908 Lengthwise feed motor origin retrieval error repeatedly occurs.	43-1) Sensor cannot detect the edge of feed base.	1)-A There is abnormality such as heavy load at mechanical section or the like.	Check mechanical section whether there is any special place to which heavy load is applied, any screw is loosened, or the like.	
		1)-B Failure or breaking of wire of sensor	Check that sensor lamp is turned ON/OFF when making metallic plate approach or separate from the sensor plane. If it is not turned ON/ OFF, failure of sensor or breaking of wire at connection section is proved.	
	43-2) Sensor signal is not transmitted to micro computer of MAIN p.c.b.	2)-A Connector of INT p.c.b. is disconnected.	Check the connection of CN78 of INT p.c.b.	
		2)-B Breaking of wire of MAIN-INT cord B (asm.)	Check whether breaking of wire is in MAIN-INT cord B (asm.). Refer to "Connection circuit diagram between control box and head".	
		2)-C Failure of MAIN p.c.b.	When the aforementioned check is OK, failure of MAIN p.c.b. is proved.	
	43-3) Motor fails to normally rotate.	3)-A Connector of INT p.c.b. is disconnected.	Check the connection of CN80 of INT p.c.b.	
		3)-B Breaking of wire of MAIN-INT cord A (asm.)	Check whether breaking of wire is in MAIN-INT cord A (asm.). Refer to "Connection circuit diagram between control box and head".	
		3)-C Failure of motor	Remove CN80 of INT p.c.b. and check by moving the feed by hand. If there is feeling of scratching, failure of motor is proved.	
		3)-D Breaking of wire of motor lead wire	Remove CN80 of INT p.c.b. and check the resistance value between respective pins. Refer to "Stepping motor/solenoid circuit diagram".	
		3)-E Failure of MAIN p.c.b.	When the aforementioned check is OK, failure of MAIN p.c.b. is proved.	

Trouble	Cause (1)	Cause (2)	Checking order and adjusting procedure	Page
44. Error E909 Needle thread trimmer motor origin retrieval error repeatedly occurs.	44-1) Sensor cannot detect the edge of cam.	1)-A There is abnormality such as heavy load at mechanical section or the like.	Check mechanical section whether there is any special place to which heavy load is applied; any screw is loosened, or the like.	
		1)-B Failure or breaking of wire of sensor.	Check that sensor lamp is turned ON/OFF when making metallic plate approach or separate from the sensor plane. If it is not turned ON/ OFF, failure of sensor or breaking of wire at connector section is proved.	
	44-2) Sensor signal is not transmitted to micro computer of MAIN p.c.b.	2)-A Connector of INT p.c.b. is disconnected.	Check the connection of CN77 of INT p.c.b.	
		2)-B Breaking of wire of MAIN-INT cord B (asm.)	Check whether breaking of wire is in MAIN-INT cord B (asm.). Refer to "Connection circuit diagram between control box and head".	
		2)-C Failure of MAIN p.c.b.	When the aforementioned check is OK, failure of MAIN p.c.b. is proved.	
	44-3) Motor fails to normally rotate.	3)-A Connector of INT p.c.b. is disconnected.	Check the connection of CN65 of INT p.c.b.	
		3)-B Breaking of wire of MAIN-INT cord B (asm.)	Check whether breaking of wire is in MAIN-INT cord B (asm.). Refer to "Connection circuit diagram between control box and head".	
		3)-C Failure of motor	Remove CN65 of INT p.c.b. and check by turning the cam by hand. If there is feeling of scratching, failure of motor is proved.	
		3)-D Breaking of wire of motor lead wire	Remove CN65 of INT p.c.b. and check the resistance value between respective pins. Refer to "Stepping motor/solenoid circuit diagram".	
		3)-E Failure of MAIN p.c.b.	When the aforementioned check is OK, failure of MAIN p.c.b. is proved.	

Trouble	Cause (1)	Cause (2)	Checking order and adjusting procedure	Page
<p>45. Error E910 Presser lifter motor origin retrieval error repeatedly occurs. Or, presser lifter continues to move.</p>	<p>45-1) Sensor cannot detect the edge of detecting plate.</p>	<p>1)-A There is abnormality such as heavy load at mechanical section or the like.</p>	<p>Check mechanical section whether there is any special place to which heavy load is applied; any screw is loosened, or the like.</p>	
		<p>1)-B Failure or breaking of wire of sensor</p>	<p>Check that sensor lamp is turned ON/OFF when making metallic plate approach or separate from the sensor plane. If it is not turned ON/OFF, failure of sensor or breaking of wire at connector section is proved.</p>	
	<p>45-2) Sensor signal is not transmitted to micro computer of MAIN p.c.b.</p>	<p>2)-A Connector of INT p.c.b. is disconnected.</p>	<p>Check the connection of CN73 of INT p.c.b.</p>	
		<p>2)-B Breaking of wire of MAIN-INT cord B (asm.)</p>	<p>Check whether breaking of wire is in MAIN-INT cord B (asm.). Refer to "Connection circuit diagram between control box and head".</p>	
		<p>2)-C Failure of MAIN p.c.b.</p>	<p>When the aforementioned check is OK, failure of MAIN p.c.b. is proved.</p>	
	<p>45-3) Motor fails to normally rotate.</p>	<p>3)-A Connector of INT p.c.b. is disconnected.</p>	<p>Check the connection of CN79 of INT p.c.b.</p>	
		<p>3)-B Breaking of wire of MAIN-INT cord A (asm.)</p>	<p>Check whether breaking of wire is in MAIN-INT cord A (asm.). Refer to "Connection circuit diagram between control box and head".</p>	
		<p>3)-C Failure of motor</p>	<p>Remove CN79 of INT p.c.b. and check by lifting the presser by hand. If there is feeling of scratching, failure of motor is proved.</p>	
		<p>3)-D Breaking of wire of motor lead wire</p>	<p>Remove CN79 of INT p.c.b. and check the resistance value between respective pins. Refer to "Stepping motor/solenoid circuit diagram.</p>	
		<p>3)-E Failure of MAIN p.c.b.</p>	<p>When the aforementioned check is OK, failure of MAIN p.c.b. is proved.</p>	

Trouble	Cause (1)	Cause (2)	Checking order and adjusting procedure	Page
46. Error E911 Bobbin thread trimmer motor origin retrieval error repeatedly occurs.	46-1) Sensor cannot detect the edge of cam.	1)-A There is abnormality such as heavy load at mechanical section or the like.	Check mechanical section whether there is any special place to which heavy load is applied; any screw is loosened or the like.	
		1)-B Failure or breaking of wire of sensor	Check that sensor lamp is turned ON/OFF when making metallic plate approach or separate from the sensor plane. If it is not turned ON/ OFF, failure of sensor or breaking of wire at sensor section is proved.	
	46-2) Sensor signal is not transmitted to micro computer of MAIN p.c.b.	2)-A Connector of INT p.c.b. is disconnected.	Check the connection of CN72 of INT p.c.b.	
		2)-B Breaking of wire of MAIN-INT cord B (asm.)	Check whether breaking of wire is in MAIN-INT cord B (asm.). Refer to "Connection circuit diagram between control box and head".	
		2)-C Failure of MAIN p.c.b.	When the aforementioned check is OK, failure of MAIN p.c.b. is proved.	
	46-3) Motor fails to normally rotate.	3)-A Connector of INT p.c.b. is disconnected.	Check the connection of CN69 of INT p.c.b.	
		3)-B Breaking of wire of MAIN-INT cord B (asm.)	Check whether breaking of wire is in MAIN-INT cord B (asm.). Refer to "Connection circuit diagram between control box and head".	
		3)-C Failure of motor	Remove CN69 of INT p.c.b. and check by turning the cam by hand. If there is feeling of scratching, failure of motor is proved.	
		3)-D Breaking of wire of motor lead wire	Remove CN69 of INT p.c.b. and check the resistance value between respective pins. Refer to "Stepping motor/solenoid circuit diagram".	
		3)-E Failure of MAIN p.c.b.	When the aforementioned check is OK, failure of MAIN p.c.b. is proved.	

Trouble	Cause (1)	Cause (2)	Checking order and adjusting procedure	Page
47. Error E915 Communication error between panel and main CPU repeatedly occurs.	47-1) There is abnormality in communication between panel and MAIN p.c.b.	1)-A Failure of MAIN p.c.b. or PANEL p.c.b.	Replace operation panel or MAIN p.c.b.	
48. Error E916 Communication error between main CPU and main shaft CPU repeatedly occurs.	48-1) There is abnormality in communication between MAIN p.c.b. and SDC p.c.b.	1)-A Connector of SDC-MAIN cord S (asm.) is disconnected. 1)-B Failure of MAIN p.c.b. or SDC p.c.b.	Check connection or breaking of wire of SDC-MAIN cord S (asm.) SDC p.c.b. CN15, MAIN p.c.b. CN32 Replace MAIN p.c.b. or SDC p.c.b.	
49. Error E918 Heat sink temperature of MAIN p.c.b. error repeatedly occurs.	49-1) Heat sink temperature of MAIN p.c.b. has risen more than 85 C.	1)-A Cooling is not performed.	Check whether cooling of control box is performed. Check whether inlet port is clogged, fan is defective, or the like.	
50. Error E943 EEPROM error occurs.	49-2) Failure of MAIN p.c.b. 50-1) EEPROM of MAIN p.c.b. cannot perform writing/reading.	1)-A EEPROM of MAIN p.c.b. is disconnected.	When the aforementioned check is OK, failure of MAIN p.c.b. is proved. Check whether EEPROM is properly mounted.	
51. Error E946 EEPROM of head relay P.C.B. writing error repeatedly occurs.	50-2) Failure of MAIN p.c.b. 51-1) EEPROM cannot perform writing/reading. 51-2) Failure of MAIN p.c.b or INT p.c.b.	1)-A Connector of MAIN-INT cord D (asm.) is disconnected.	When the aforementioned check is OK, failure of MAIN p.c.b. is proved. Check connection or breaking of wire of MAIN-INT cord D (asm.). Refer to "Connection circuit diagram between control box and head". When the aforementioned check is OK, failure of MAIN p.c.b. or INT p.c.b. is proved.	
52. Error E999 Cloth cutting knife sensor error repeatedly occurs. (When knife is held down.)	52-1) Sensor signal is not transmitted to micro computer of MAIN p.c.b. 52-2) Cloth cutting knife bites in cloth and does not return.	1)-A Connector of INT p.c.b. is disconnected. 1)-B Breaking of wire of MAIN-INT cord B (asm.) 1)-C Failure of MAIN p.c.b. 1)-D Adjustment of the position of knife is improper. 2)-A Cloth cutting knife is broken. 2)-B Power shortage	Check the connection of CN67 of INT p.c.b. Check whether breaking of wire is in MAIN-INT cord B (asm.). Refer to "Connection circuit diagram between control box and head". When the aforementioned check is OK, failure of MAIN p.c.b. is proved. Re-adjust the knife sensor. Replace the knife. Increase power by memory switch.	

16. TIME CHART

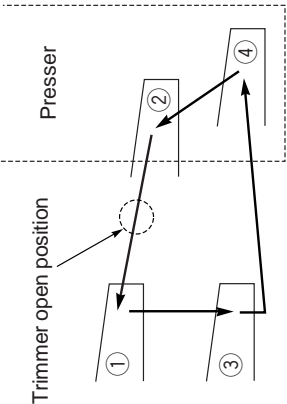
Function name	Item	Details
Sewing motion sequence	1-pedal	<p>Presser lifter : 5-phase stepping motor (half step control) Presser lifter is controlled at 3 positions of max. height position (variable), cloth set position (variable) and sewing position. Needle thread trimmer : 2-phase stepping motor (half step control) Needle thread trimmer is controlled at 4 positions of mechanical connection cut-off position, roll-in at sewing start position (variable), waiting position, trimming position.</p>  <p>[Motor rotation position]</p> <p>① Mechanical connection cut-off position ② Roll-in at sewing start position ③ Waiting position ④ Trimming position</p> <p>Bobbin thread trimmer : 2-phase stepping motor (half step control) Bobbin thread trimmer is controlled at 4 positions of trimmer open position, small amount open position, waiting position, and trimming position.</p> <p>[Motor rotation position]</p> <p>⑩ Small amount open position ⑪ Trimmer open position ⑫ Waiting position ⑬ Trimming position</p> <p>Motion sequence</p> <p>Needle thread trimmer Bobbin thread trimmer</p> <p>Sewing machine speed</p> <p>Allocate moving pulse amount to K21 of maintenance personnel level and at the same time of change, perform writing to EEPROM of machine head.</p> <p>Machine starts at 3rd step of pedal.</p> <p>Cloth set position at 1st step of pedal</p> <p>Max. height position at pedal free</p> <p>Height of presser</p> <p>Motion starts at the move of set sewing length. ① ② ③ ④</p> <p>Motion starts at the set angle of the last stitch. ④ ③ ② ① ⑫ ⑬ ⑭</p> <p>Start-up of machine Bobbin thread trimmer starts moving to trimmer open position after outputting 3 pulses in total from small amount open by outputting 1 pulse per set time of designer level L06.</p> <p>Motion starts after set time. (30 ms)</p> <p>Presser automatically goes up at the completion of machine motion. (Max. position)</p>

Details

Presser lifter : Presser is raised as much as depressing amount of left pedal.
 Needle thread trimmer and bobbin thread trimmer are controlled by the same way of 1-pedal.

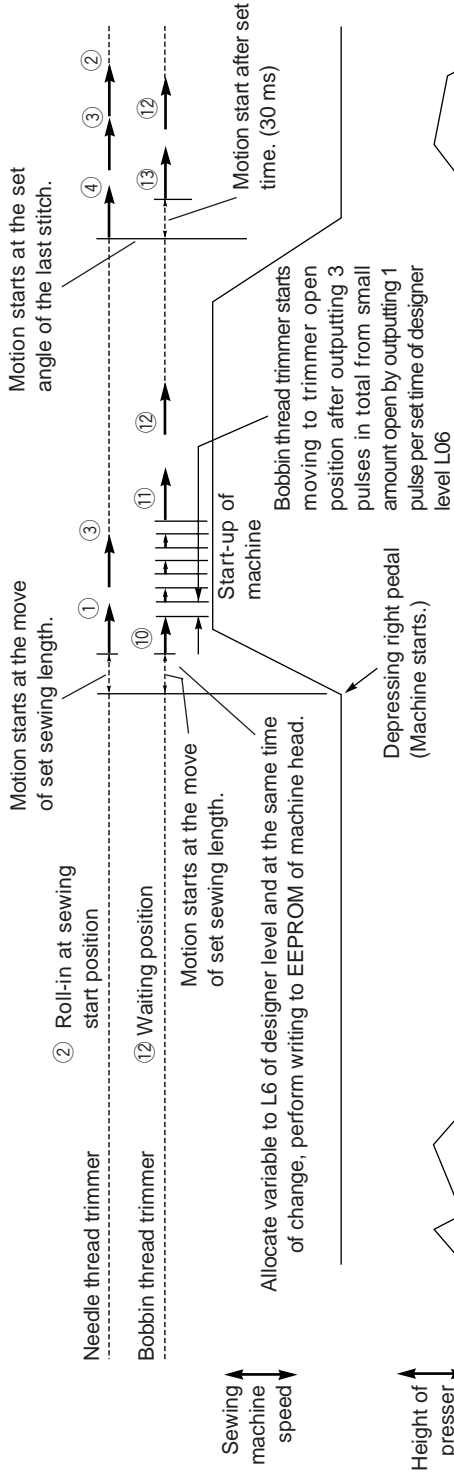

Presser goes up as much as depressing amount of left pedal by stepping motor.

Presser goes up as much as depressing amount of left pedal when it is depressed at the completion of machine motion.

Presser goes up as much as depressing amount of left pedal as much as depressing amount of left pedal by stepping motor.

Function name	Item
Sewing motion sequence	Electric 2-pedal

17. CIRCUIT DIAGRAM

(1) Block diagram A (3-phase 200 to 240V)

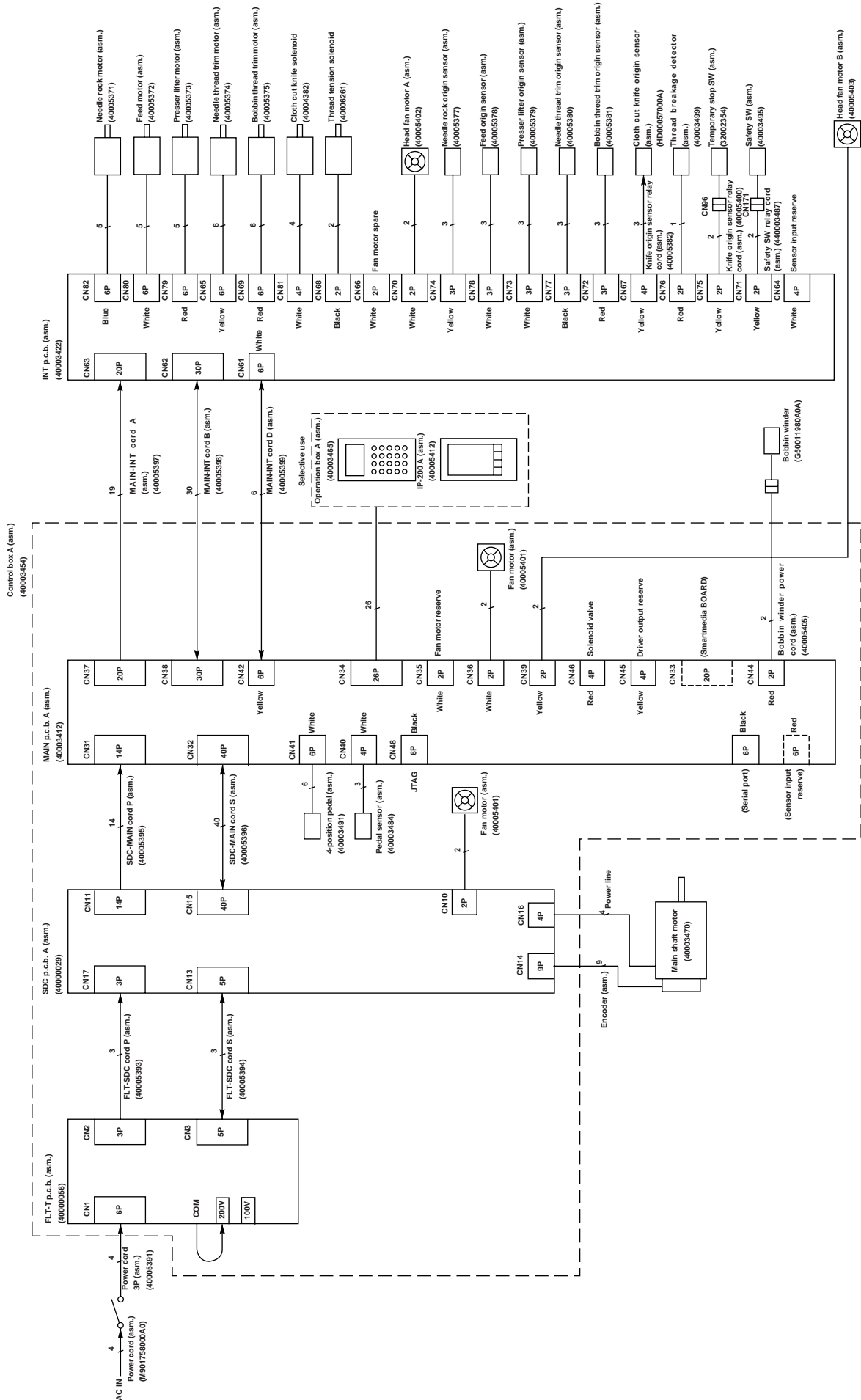

(2) Block diagram B (Single phase 230V (for CE))

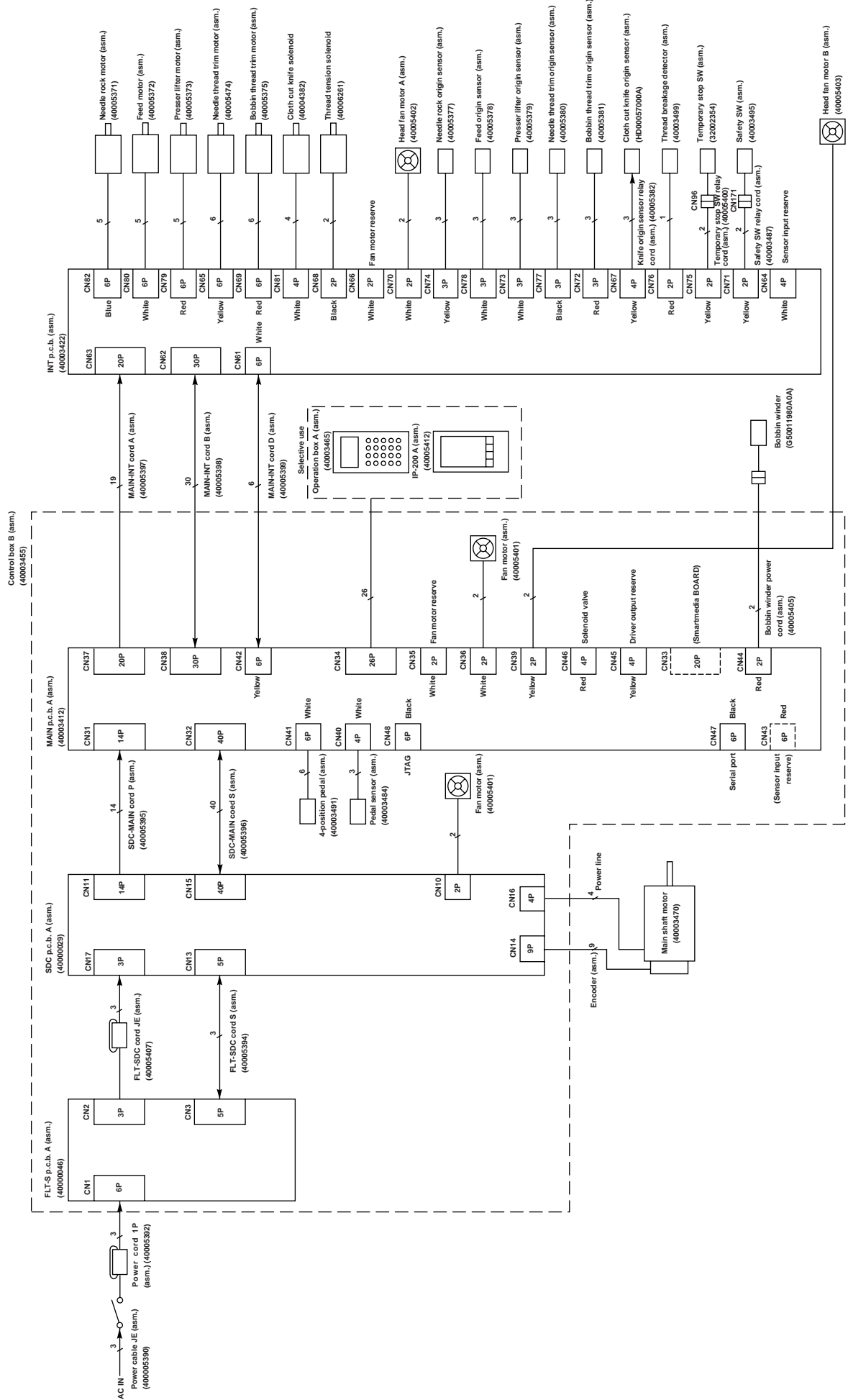

(3) Block diagram C (Single phase 220 to 240V)

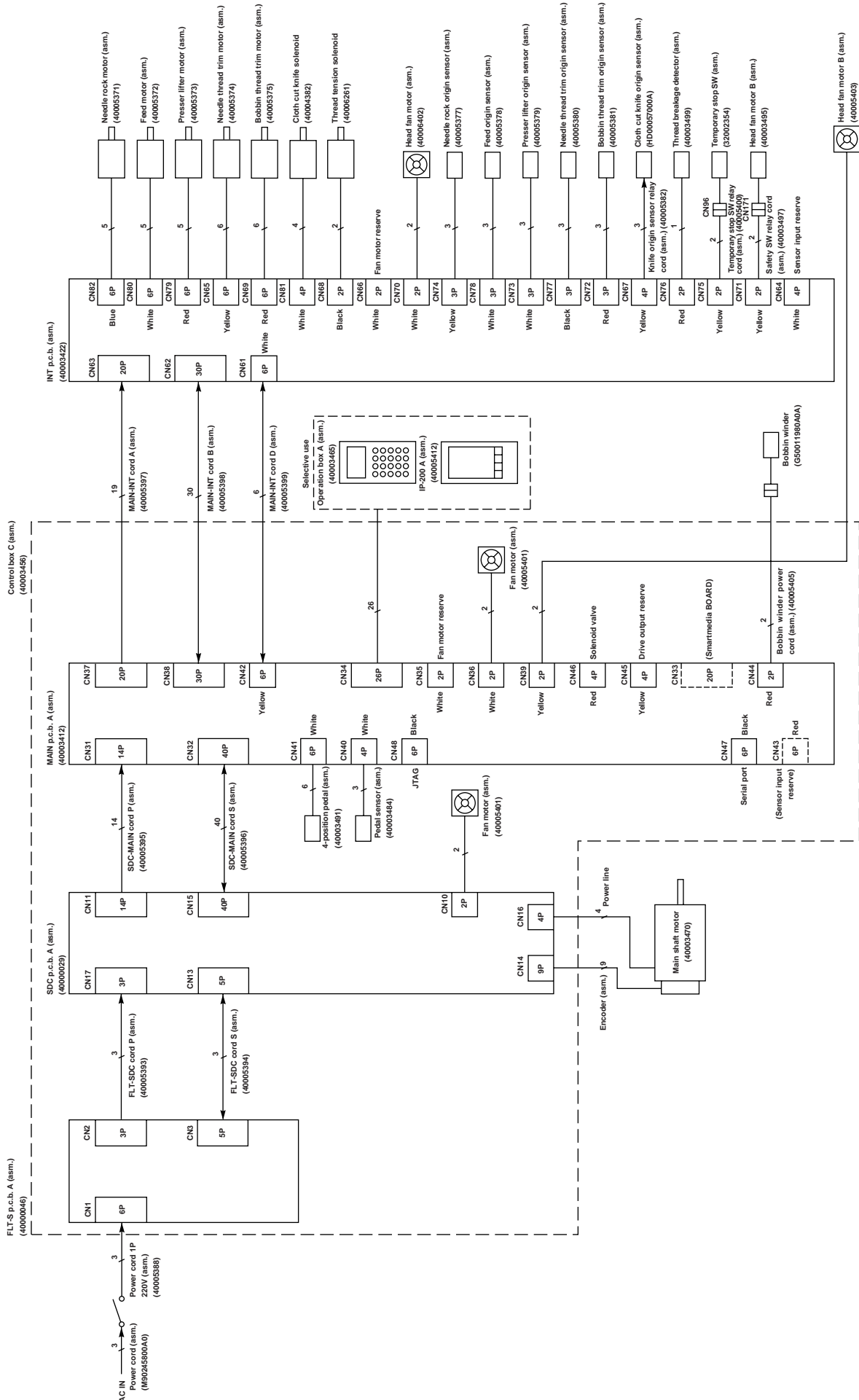

(4) Power circuit diagram (3-phase 200 to 240V)

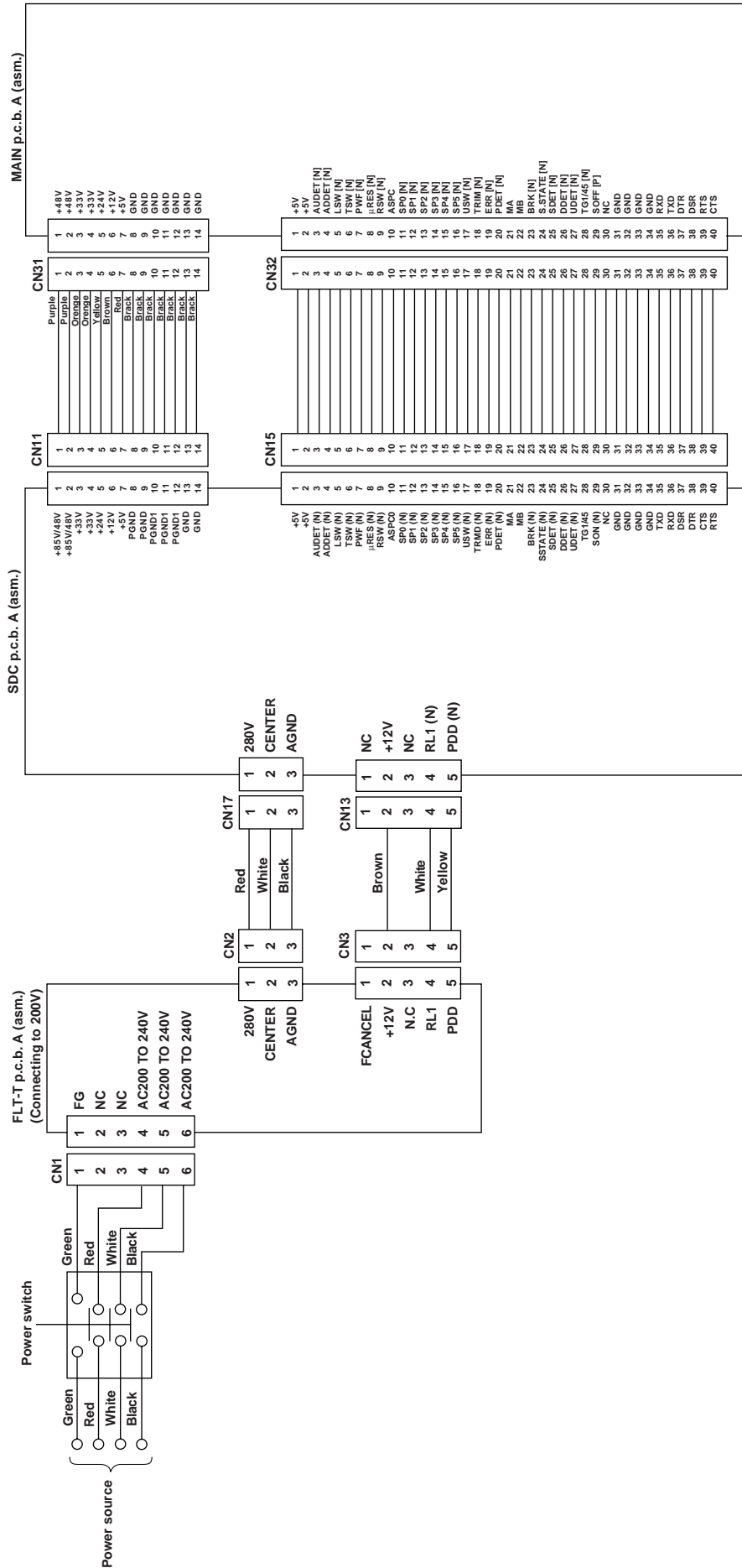

(5) Power circuit diagram (Single phase 220 to 240V)

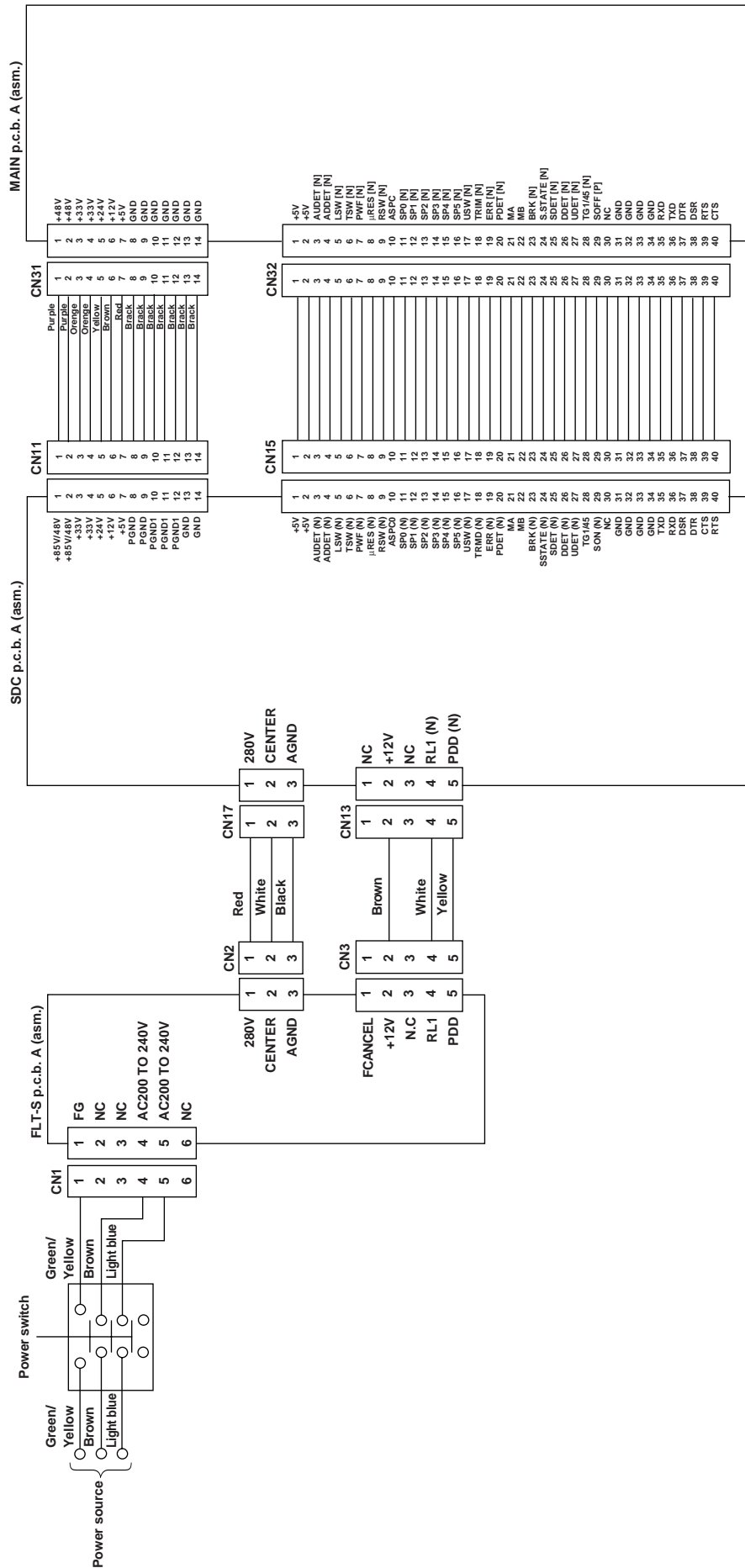

(6) Power circuit diagram (Single phase 100V)

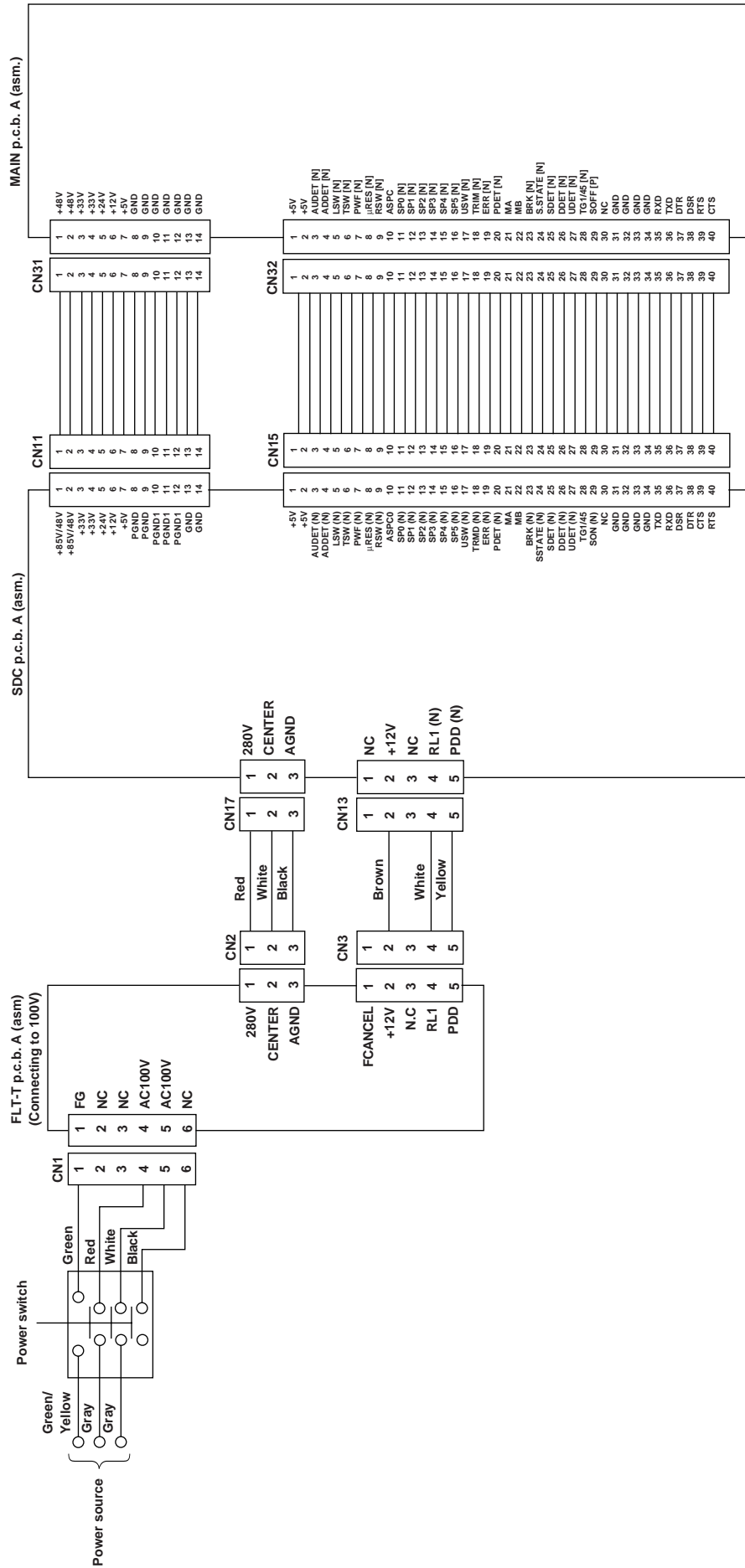

(7) Servo motor circuit diagram

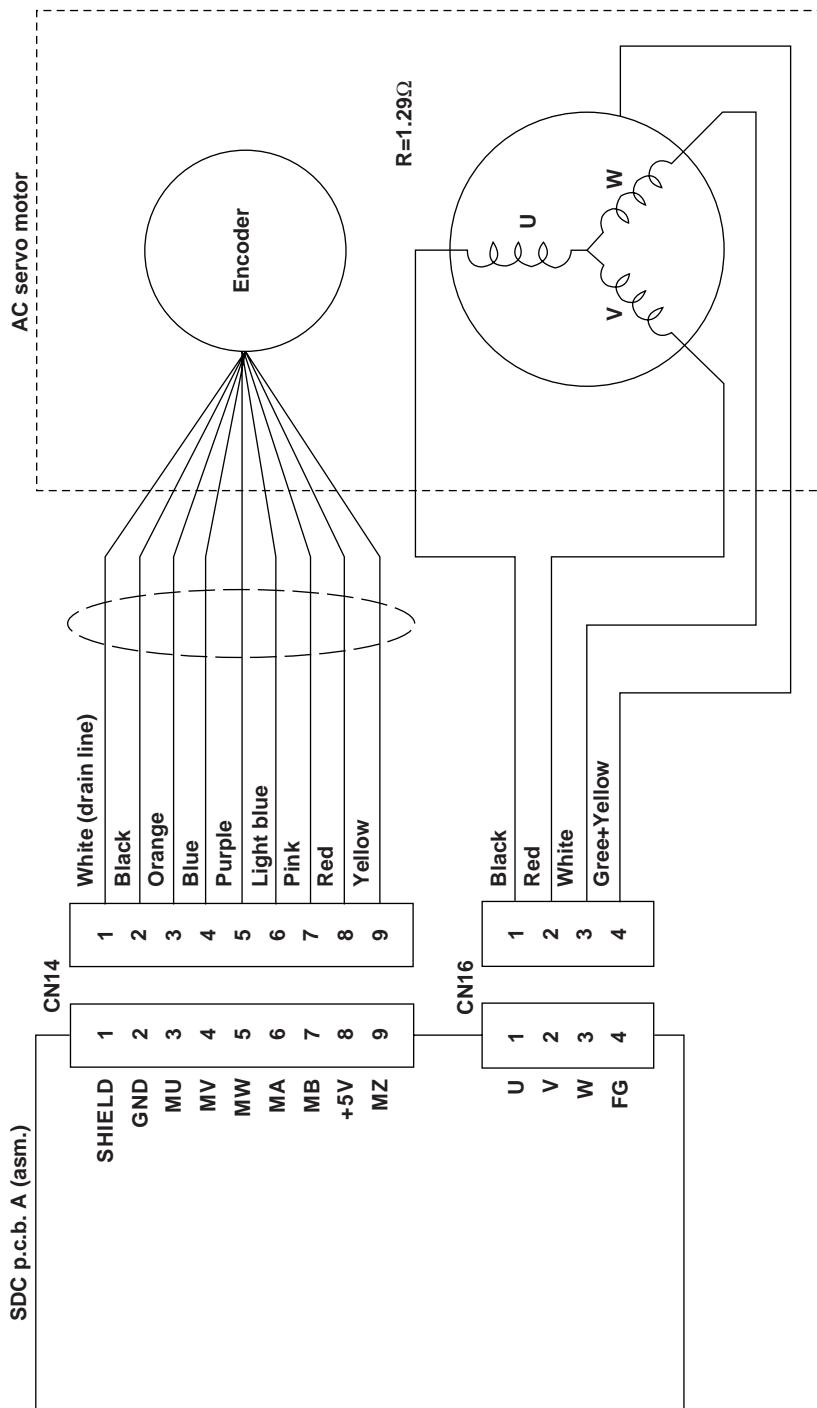

(8) Stepping motor/solenoid circuit diagram

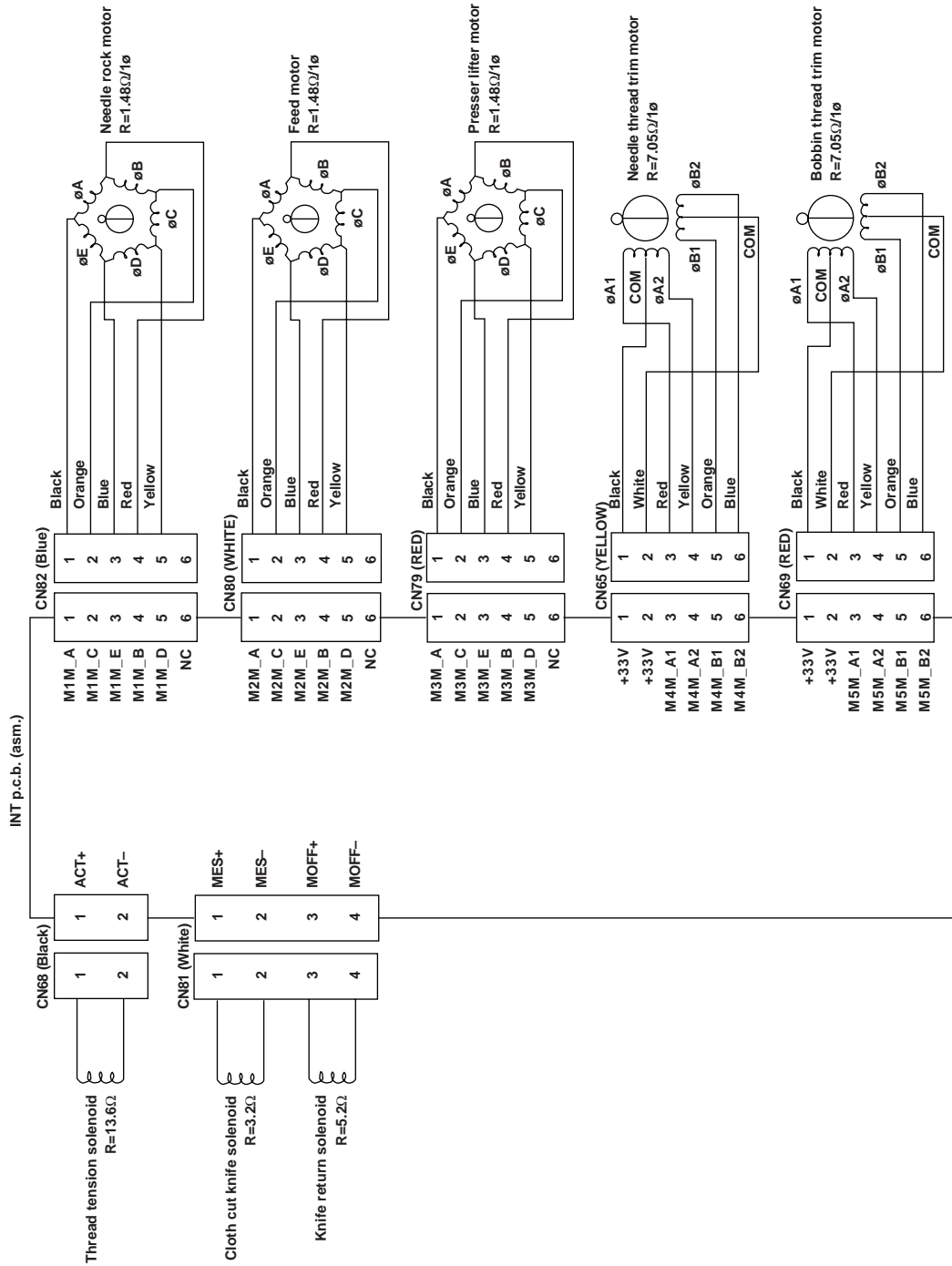

(9) Head sensor circuit diagram

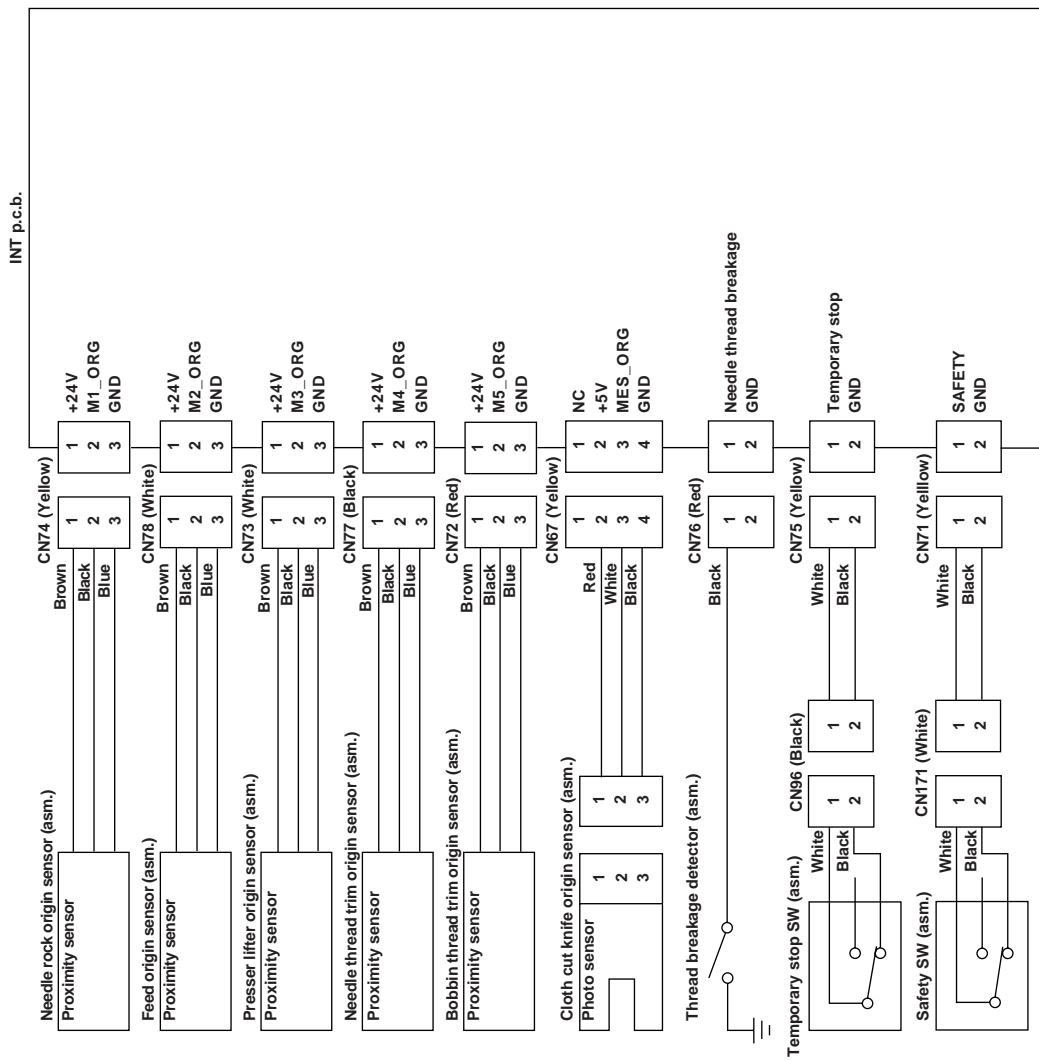

(10) Pedal switch circuit diagram

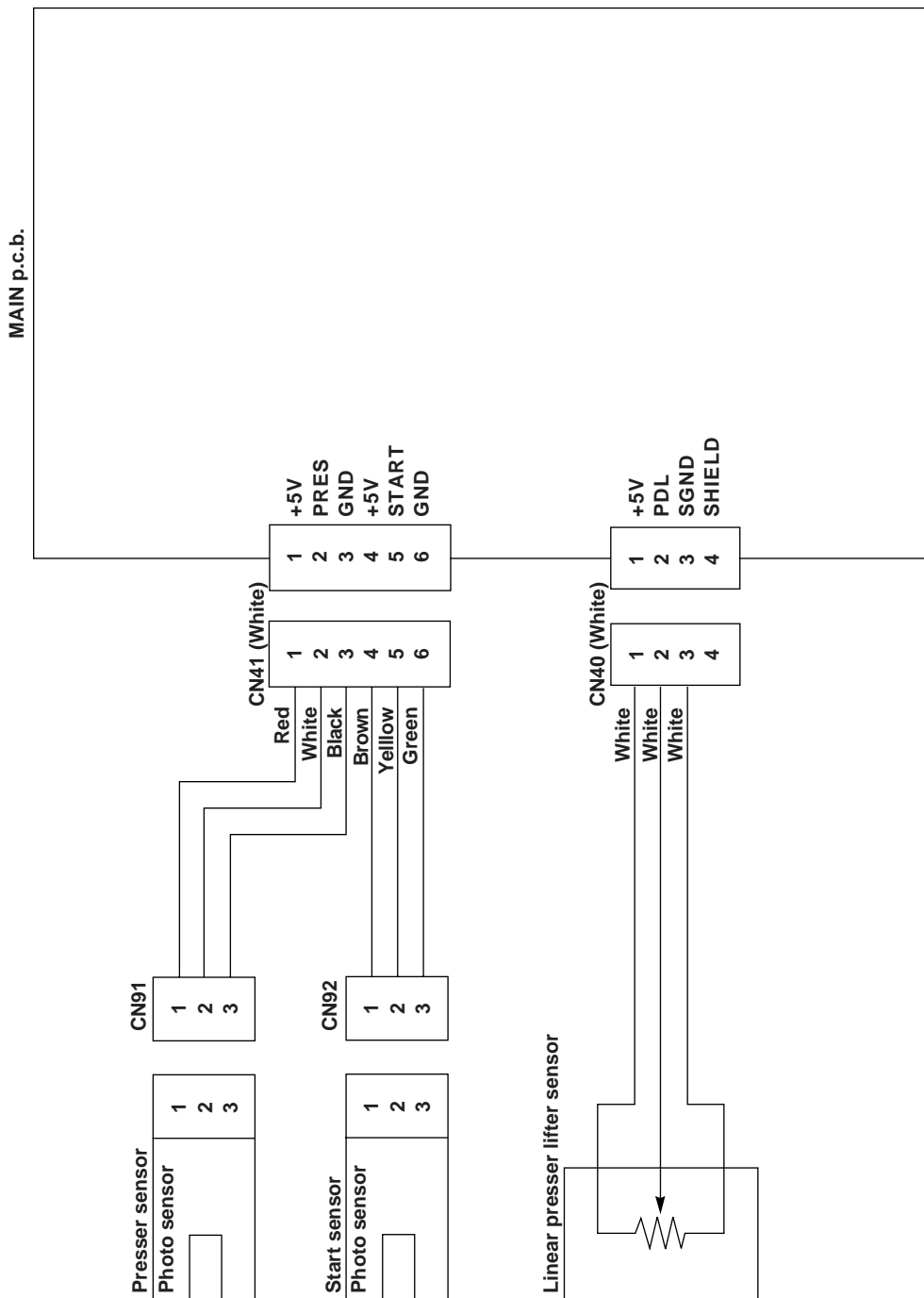

(11) Connection circuit diagram between control box and head

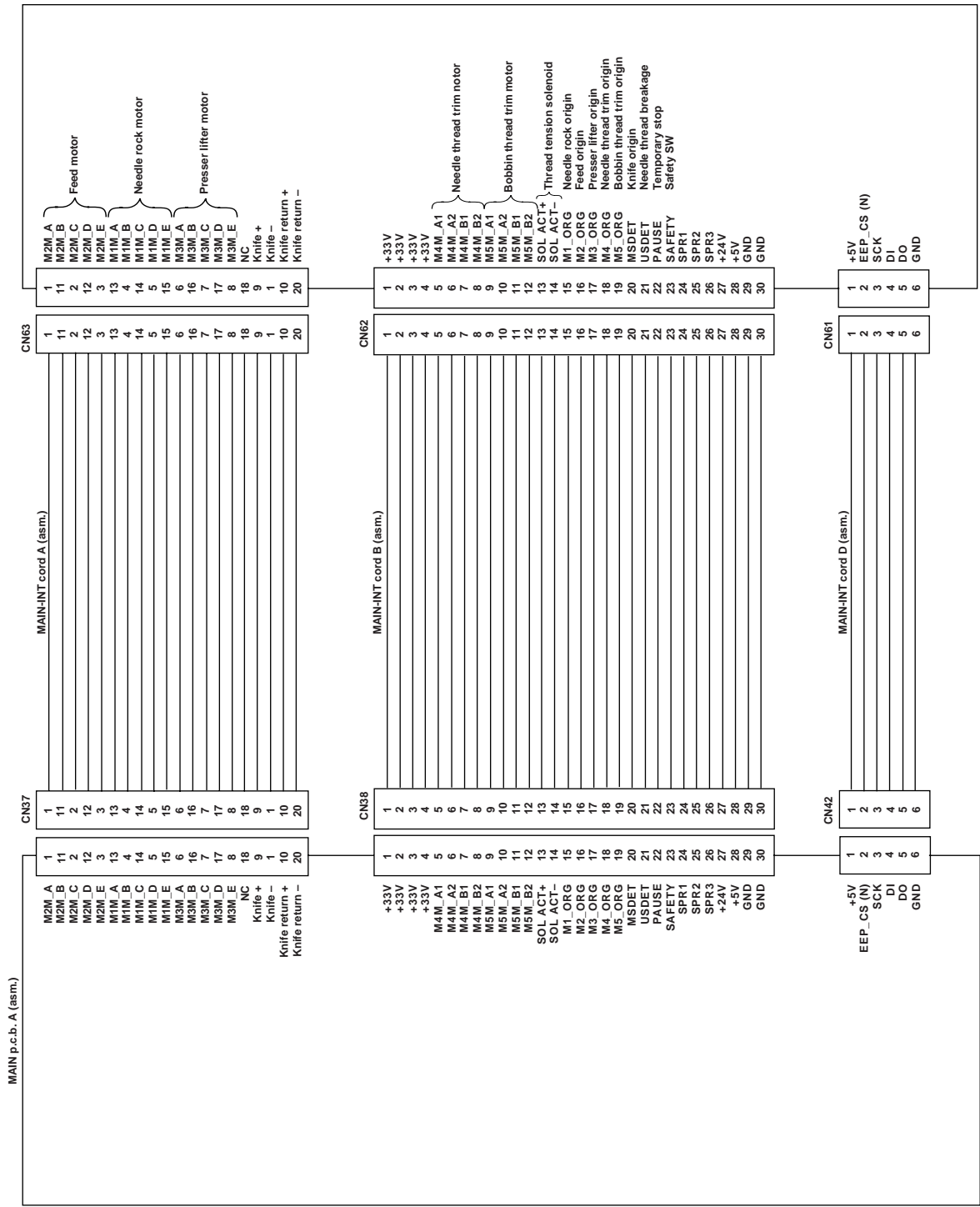



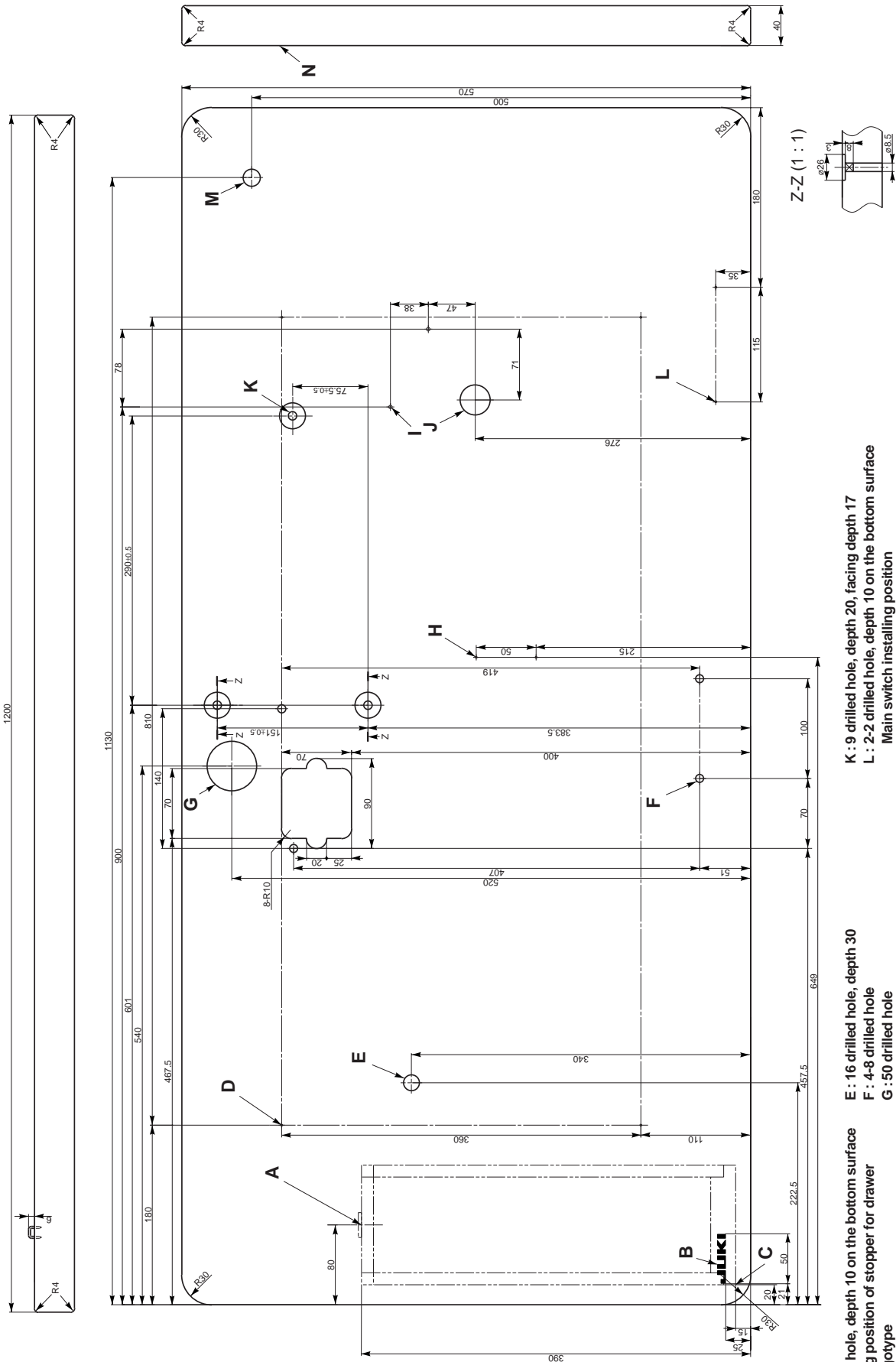

























































18. DRAWING OF THE TABLE



- A : 2 drilled hole, depth 10 on the bottom surface
- Installing position of stopper for drawer
- B : JUKI logotype
- C : 2 drilled hole, depth 10 on the bottom surface
- Installing position of drawer
- D : 4-2 drilled hole depth 10 on the bottom surface
- Stand installing hole
- E : 16 drilled hole, depth 30
- F : 4-8 drilled hole
- G : 50 drilled hole
- H : 2-2 drilled hole, depth 10 on the bottom surface
- Pedal switch installing position
- I : 2-3.5 drilled hole, depth 14
- J : 30 drilled hole
- K : 9 drilled hole, depth 20, facing depth 17
- L : 2-2 drilled hole, depth 10 on the bottom surface
- Main switch installing position
- M : 17 drilled hole
- N : Right side

A large rectangular area with rounded corners, containing a series of horizontal lines for writing. The lines are evenly spaced and cover the lower two-thirds of the page.

INITIAL VALUE DATA FOR EACH SHAPE TABLE

No.	Item	Unit	Shape selection Level 1 (12 shapes)												Shape selection Level 2 (20 shapes)								Shape selection Level 3 (30 shapes)													
			Shape selection Level 1 (12 shapes)												Shape selection Level 2 (20 shapes)								Shape selection Level 3 (30 shapes)													
																																				
S01	Sewing shape																																			
S02	Cloth cutting length	mm	12.7	12.7	12.7	12.7	12.7	12.7	12.7	12.7	12.7	12.7	12.7	12.7	12.7	12.7	12.7	12.7	12.7	12.7	12.7	12.7	12.7	12.7	12.7	12.7	12.7	12.7	12.7	12.7	12.7	12.7	12.7	12.7	12.7	
S03	Knife groove width, right	mm	0.10	0.10	0.10	0.10	0.10	0.10	0.10	0.10	0.10	0.10	0.10	0.10	0.10	0.10	0.10	0.10	0.10	0.10	0.10	0.10	0.10	0.10	0.10	0.10	0.10	0.10	0.10	0.10	0.10	0.10	0.10	0.10	0.10	0.10
S04	Knife groove width, left	mm	0.10	0.10	0.10	0.10	0.10	0.10	0.10	0.10	0.10	0.10	0.10	0.10	0.10	0.10	0.10	0.10	0.10	0.10	0.10	0.10	0.10	0.10	0.10	0.10	0.10	0.10	0.10	0.10	0.10	0.10	0.10	0.10	0.10	0.10
S05	Overedging width, left	mm	1.70	1.70	1.70	1.70	1.70	1.70	1.70	1.4	1.4	1.4	1.4	1.70	1.70	1.70	1.70	1.4	1.4	1.70	1.70	1.70	1.70	1.70	1.70	1.70	1.70	1.70	1.70	1.70	1.70	1.70	1.70	1.70	1.70	1.70
S06	Left/right shape ratio (right side in terms of left side)	%	100	100	100	100	100	100	100	100	100	100	100	100	100	100	100	100	100	100	100	100	100	100	100	100	100	100	100	100	100	100	100	100	100	100
S07	Pitch at parallel section	mm	0.35	0.35	0.35	0.35	0.35	0.35	0.35	0.35	0.35	0.35	0.35	0.35	0.35	0.35	0.35	0.35	0.35	0.35	0.35	0.35	0.35	0.35	0.35	0.35	0.35	0.35	0.35	0.35	0.35	0.35	0.35	0.35	0.35	0.35
S08	2nd bar-tacking length	mm	1.0	-	1.0	-	1.5	3.0	1.0	-	1.5	3.0	-	1.0	1.5	3.0	-	-	-	-	-	1.5	3.0	-	-	-	-	-	-	-	-	-	-	-	-	-
S09	1st bar-tacking length	mm	1.0	-	-	-	-	-	-	-	-	-	-	-	-	-	-	-	-	1.0	1.0	1.0	1.0	1.0	1.0	1.0	1.0	1.0	1.0	1.0	1.0	1.0	1.0	1.0	1.0	1.0
S10	Bar-tacking width, right compensation	mm	0.0	-	0.0	-	0.0	-	0.0	-	0.0	-	0.0	-	0.0	0.0	0.0	-	-	-	0.0	0.0	0.0	0.0	0.0	0.0	0.0	0.0	0.0	0.0	0.0	0.0	0.0	0.0	0.0	0.0
S11	Bar-tacking width, left compensation	mm	0.0	-	0.0	-	0.0	-	0.0	-	0.0	-	0.0	-	0.0	0.0	0.0	-	-	-	0.0	0.0	0.0	0.0	0.0	0.0	0.0	0.0	0.0	0.0	0.0	0.0	0.0	0.0	0.0	0.0
S12	Taper bar-tacking offset, left	mm	-	-	-	-	-	0.85	-	-	-	0.85	-	-	-	-	0.85	-	-	-	-	-	-	-	-	-	-	-	-	-	-	-	-	-	-	-
S13	Taper bar-tacking offset, right	mm	-	-	-	-	-	0.85	-	-	-	0.85	-	-	-	-	0.85	-	-	-	-	-	-	-	-	-	-	-	-	-	-	-	-	-	-	-
S14	Eyelet shape length	mm	-	-	-	-	-	-	2.0	2.0	2.0	2.0	-	-	-	-	-	-	2.0	2.0	-	-	-	-	-	-	-	-	-	-	-	-	-	-	-	-
S15	Number of stitches of eyelet shape	Stitch	-	-	-	-	-	-	3	3	3	3	-	-	-	-	-	-	3	3	-	-	-	-	-	-	-	-	-	-	-	-	-	-	-	-
S16	Eyelet width	mm	-	-	-	-	-	-	1.0	1.0	1.0	1.0	-	-	-	-	-	-	1.0	1.0	-	-	-	-	-	-	-	-	-	-	-	-	-	-	-	-
S17	Eyelet length	mm	-	-	-	-	-	-	3.0	3.0	3.0	3.0	-	-	-	-	-	-	3.0	3.0	-	-	-	-	-	-	-	-	-	-	-	-	-	-	-	-
S18	Round type shape length	mm	-	2.0	2.0	2.0	2.0	2.0	-	2.0	-	-	2.0	2.0	2.0	2.0	2.0	2.0	2.0	2.0	2.0	2.0	2.0	2.0	2.0	2.0	2.0	2.0	2.0	2.0	2.0	2.0	2.0	2.0	2.0	2.0
S19	Number of stitches of radial shape	Stitch	-	-	3	3	3	3	-	3	-	-	-	-	-	-	-	-	-	3	-	-	-	-	-	-	-	-	-	-	-	-	-	-	-	-
S20	Radial shape reinforcement (with/without)		-	-	Without	Without	Without	Without	-	Without	-	-	-	-	-	-	-	-	-	Without	-	-	-	-	-	Without	Without	Without	-	-	-	-	-	-	-	-
S21	Pitch at bar-tacking section	mm	0.30	0.30	0.30	0.30	0.30	0.30	0.30	-	0.30	0.30	0.25	0.30	0.25	0.25	0.25	0.25	0.25	0.30	0.30	0.25	0.30	0.30	0.30	0.25	0.30	0.25	0.30	0.25	0.30	0.25	0.30	0.25	0.30	
S22	1st clearance	mm	1.5	1.5	1.5	1.5	1.5	1.5	1.5	1.5	1.5	1.5	1.5	1.5	1.5	1.5	1.5	1.5	1.5	1.5	1.5	1.5	1.5	1.5	1.5	1.5	1.5	1.5	1.5	1.5	1.5	1.5	1.5	1.5	1.5	1.5
S23	2nd clearance	mm	1.3	1.3	1.3	1.3	1.3	1.3	1.3	1.3	1.3	1.3	1.3	1.3	1.3	1.3	1.3	1.3	1.3	1.3	1.3	1.3	1.3	1.3	1.3	1.3	1.3	1.3	1.3	1.3	1.3	1.3	1.3	1.3	1.3	1.3
S31	1/2 stitching		Single	Single	Single	Single	Single	Single	Single	Single	Single	Single	Single	Single	Single	Single	Single	Single	Single	Single	Single	Single	Single	Single	Single	Single	Single	Single	Single	Single	Single	Single	Single	Single	Single	Single
S32	Double stitching cross selection		<	<	<	<	<	<	<	<	<	<	<	<	<	<	<	<	<	<	<	<	<	<	<	<	<	<	<	<	<	<	<	<	<	<
S33	Double stitching width compensation	mm	0.0	0.0	0.0	0.0	0.0	0.0	0.0	0.0	0.0	0.0	0.0	0.0	0.0	0.0	0.0	0.0	0.0	0.0	0.0	0.0	0.0	0.0	0.0	0.0	0.0	0.0	0.0	0.0	0.0	0.0	0.0	0.0	0.0	
S34	Number of times of basting	Time	0	0	0	0	0	0	0	0	0	0	0	0	0	0	0	0	0	0	0	0	0	0	0	0	0	0	0	0	0	0	0	0	0	0
S35	Pitch of basting	mm	4.0	4.0	4.0	4.0	4.0	4.0	4.0	4.0	4.0	4.0	4.0	4.0	4.0	4.0	4.0	4.0	4.0	4.0	4.0	4.0	4.0	4.0	4.0	4.0	4.0	4.0	4.0	4.0	4.0	4.0	4.0	4.0	4.0	4.0
S36	Rolling length of basting	mm	8.0	8.0	8.0	8.0	8.0	8.0	8.0	8.0	8.0	8.0	8.0	8.0	8.0	8.0	8.0	8.0	8.0	8.0	8.0	8.0	8.0	8.0	8.0	8.0	8.0	8.0	8.0	8.0	8.0	8.0	8.0	8.0	8.0	8.0
S37	Rolling pitch of basting	mm	0.8	0.8	0.8	0.8	0.8	0.8	0.8	0.8	0.8	0.8	0.8	0.8	0.8	0.8	0.8	0.8	0.8	0.8	0.8	0.8	0.8	0.8	0.8	0.8	0.8	0.8	0.8	0.8	0.8	0.8	0.8	0.8	0.8	0.8
S38	Rolling width of basting	mm	1.5	1.5	1.5	1.5	1.5	1.5	1.5	1.5	1.5	1.5	1.5	1.5	1.5	1.5	1.5	1.5	1.5	1.5	1.5	1.5	1.5	1.5	1.5	1.5	1.5	1.5	1.5	1.5	1.5	1.5	1.5	1.5	1.5	1.5
S39	Compensation before/after needle entry of basting	mm	1.5	1.5	1.5	1.5	1.5	1.5	1.5	1.5	1.5	1.5	1.5	1.5	1.5	1.5	1.5	1.5	1.5	1.5	1.5	1.5	1.5	1.5	1.5	1.5	1.5	1.5	1.5	1.5	1.5	1.5	1.5	1.5	1.5	1.5
S40	Compensation left/right needle entry of basting	mm	0.0	0.0	0.0	0.0	0.0	0.0	0.0	0.0	0.0	0.0	0.0	0.0	0.0	0.0	0.0	0.0	0.0	0.0	0.0	0.0	0.0	0.0	0.0	0.0	0.0	0.0	0.0	0.0	0.0	0.0	0.0	0.0	0.0	0.0
S41	Compensation of left side position of basting	mm	0.0	0.0	0.0	0.0	0.0	0.0	0.0	0.0	0.0	0.0	0.0	0.0	0.0	0.0	0.0	0.0	0.0	0.0	0.0	0.0	0.0	0.0	0.0	0.0	0.0	0.0	0.0	0.0	0.0	0.0	0.0	0.0	0.0	0.0
S42	Compensation of right side position of basting	mm	0.0	0.0	0.0	0.0	0.0	0.0	0.0	0.0	0.0	0.0	0.0	0.0	0.0	0.0	0.0	0.0	0.0	0.0	0.0	0.0	0.0	0.0	0.0	0.0	0.0	0.0	0.0	0.0	0.0	0.0	0.0	0.0	0.0	0.0
S44	Speed setting of basting	rpm	2000	2000	2000	2000	2000	2000	2000	2000	2000	2000	2000	2000	2000	2000	2000	2000	2000	2000	2000	2000	2000	2000	2000	2000	2000	2000	2000	2000	2000	2000	2000	2000	2000	2000
S51	Left parallel section tension		120	60	120	120	120	120	60	60	60	60	60	60	60	60	60	60	60	120	60	60	60	60	60	60	60	60	60	60	60	60	60	60	60	60
S52	Right parallel section tension		1																																	

JUKI®

JUKI CORPORATION

MARKETING & SALES H.Q.
8-2-1, KOKURYO-CHO,
CHOFU-SHI, TOKYO 182-8655, JAPAN
PHONE : (81)3-3480-2357 • 2358
FAX : (81)3-3430-4909 • 4914

Copyright © 2005 JUKI CORPORATION.
All rights reserved throughout the world.

This manual uses environment-friendly soyink.



JUKI CORPORATION HEAD OFFICE

The environmental management system to promote and conduct
①the technological and technical research, the development and design of the products in which the environmental impact is considered,
②the conservation of the energy and resources, and the recycling, in the research, development, design, distribution, sale and maintenance service of the industrial sewing machines, household sewing machines and industrial-use robots, etc. and in the sale and maintenance service of data entry system and in the purchase, distribution and sale of the household commodities including the healthcare products.



Please do not hesitate to contact our distributors or agents in your area for further information when necessary.

* **The description covered in this engineer's manual is subject to change for improvement of the commodity without notice.**