

AB-1360

Automatic 1-needle shoelace loop attaching machine

This is the automatic sewing machine which is ideally suited for sewing shoelace loops of sports shoes.



Automatic 1-needle shoelace loop attaching machine

AB-1360

AB-1360

Attaching shoelace loops



This automatic sewing machine attaches shoelace loops to the tongue section of sports shoes. Since the sewing machine is provided with an LED marking light (cross shape light), misalignment will not occur. Shoelace loop attaching process can be carried out in sequence, thereby realizing the industry's shortest cycle time.

Productivity

Higher productivity is achieved by automatizing the steps of procedure of sewing shoelace loops of sports shoes.

Deskilled labor saving

Cutting, folding and sewing of shoelace loops can be carried out in one process, thereby promoting labor-saving and deskilling.



Constant-dimension loop cutting is achieved by the adoption of heat cutter.

Loop size adjustment and loop specification changing have been digitalized.



The AB-1360 has adopted, as its operation panel, the IP-420 which has a large color liquid crystal touch panel. With this operation panel, the operator can change the loop shape or sewing pattern.

Specifications

Model name	AB-1360
On-board machine head	LK-1962/ABH (Specifically-designed semi-dry machine head based on the LK-1900A)
Sewing speed (max.)	2,500sti/min*
Lift of work clamp foot	20mm
Hook in use	Horizontal-axis rotary hook
Needle bar stroke	45.7mm
Needle	DP×17 (#18)
Shoelace loop width	6~12mm
Finished length of shoelace loop	15~20mm

* sti/min stands for Stitches per Minute.

When You Place Orders

Please note when placing orders, that the model name should be written as follows:

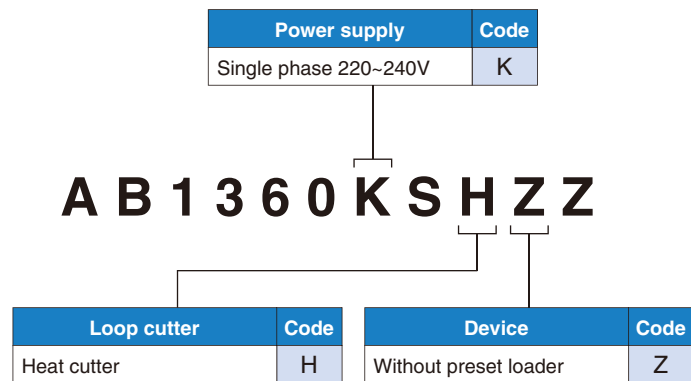

JUKI ECO PRODUCTS

The AB-1360 is an eco-friendly product which complies with JUKI ECO PRODUCTS standards for protecting the environment.



- The sewing machine complies with the "Juki Group Green Procurement Guidelines" on the use of hazardous substances, which is stricter than other restrictions, such as those of the RoHS Directive.

For details of JUKI ECO PRODUCTS, refer to: http://www.juki.co.jp/eco_e/index.html

* The RoHS Directive is an EU Directive limiting the use of 6 hazardous substances (lead, hexavalent chromium, mercury, cadmium, PBB and PBDE) in electrical and electronic equipment.
The Juki Green Procurement Guideline is the voluntarily established criteria to eliminate not only the aforementioned six substances, but also other ones which also adversely affect the environment.



Registered Organization : JUKI CORPORATION Head Office
The Scope of the Registration : The activities of research, development, design, sales, distribution, and maintenance services of industrial sewing machines, household sewing machines and industrial robots, etc., including sales and maintenance services of data entry systems.

JUKI
JUKI CORPORATION
SEWING MACHINERY BUSINESS UNIT

2-11-1, TSURUMAKI, TAMA-SHI,
TOKYO 206-8551, JAPAN
PHONE : (81) 42-357-2254
FAX : (81) 42-357-2274
<http://www.juki.com>

- * Specifications and appearance are subject to change without prior notice for improvement.
- * Read the instruction manual before putting the machine into service to ensure safety.
- * This catalogue prints with environment-friendly soyink on recycle paper.