



HIGHLEAD

GC2008-M/GC2008-MD

High Speed Lockstitch Sewing Machine

Instruction Manual
Parts Catalog

SHANGHAI HUIGONG NO.3 SEWING MACHINE FACTORY

----- CONTENTS -----

1. PRECAUTIONS BEFORE STARTING OPERATION.....	1
1) Safety precautions.....	1
2) Precaution before Starting Operation.....	1
3) Precaution for Operating Conditions.....	1
2. MAIN SPECIFICATIONS.....	1
3. PRECAUTIONS AND LUBRICATION.....	2
1) Cleaning the machine.....	2
2) Examination.....	2
3) Oiling.....	2
4. REPLACE NEEDLES.....	2
5. NEEDLE, THREAD AND MATERIAL TO BE SEWN.....	3
6. THREADING.....	3
7. WINDING ADJUSTMENT.....	3
8. SET STITCH LENGTH AND REVERSE FEEDING.....	3
9. POSITION PRESSER BAR.....	4
10. ADJUST THE PRESSURE OF PRESSER FOOT.....	4
11. ADJUSTING OF UPPER THREAD TENSION.....	4
12. ADJUST THREAD TENSION.....	5
13. ADJUSTING OF THREAD TENSION.....	5
14. ADJUSTING OF THE THREAD GUIDE.....	5
15. TIME NEEDLE TO ROTATING HOOK.....	5
1) Adjusting the needle position.....	5
2) Adjusting the hook point timing.....	6
16. REPLACE ROTATING HOOK.....	6
17. ADJUST THE HEIGHT OF FEED DOG.....	7
18. ADJUST THE POSITION OF FEED DOG.....	7
19. TIME FEED MOTION TO NEEDLE MOTION.....	8
20. LUBRICATION ADJUSTMENT.....	8
21. REGULAR CLEANING.....	9
SPECIAL INSTRUCTION OF GC2008-MD	
22. ADJUSTMENT OF NEEDLE BAR STOP POSITION.....	9
23. REVERSE SEWING.....	10
24. THREAD WIPER.....	10
25. ADJUSTMENT OF KNIFE ENGAGEMENT.....	10
1) Position of fixed knife.....	10
2) Knife engagement amount.....	10
3) Adjustment of knife engagement pressure.....	11
26. PARTS CATALOG.....	12
A) Arm bed & Its accessories.....	12
B) Needle bar and thread take-up mechanism.....	15

- C) Feeding and feed lifting & lower shaft mechanism 18
- D) Stitch regulator mechanism 21
- E) Presser foot mechanism 24
- F) Oil lubrication mechanism 26
- G) Knife mechanism 28
- H) Wiper mechanism 31
- I) Touch back mechanism & Detector mechanism 33
- J) Accessories 35

1. PRECAUTIONS BEFORE STARTING OPERATION

1) Safety Precautions:

- (1) When turning the power on, keep your hands and fingers away from the area around/under the needle and the area around the balance wheel.
- (2) Power must be turned off when the machine is not in use, or when the operator leaves the seat.
- (3) Power must be turned off when tilting the machine head, installing or removing the "V" belt, adjusting the machine, or when replacing.
- (4) Avoid placing fingers, hairs, bars etc., near the balance wheel, "V" belt, bobbin winder balance wheel, or motor when the machine is in operation.
- (5) Do not insert fingers into the thread take-up cover, under/around the needle, or balance wheel when the machine is in operation.
- (6) If a belt cover, finger guard, eye guard are installed, do not operate the machine without these safety devices.

2) Precautions before Starting Operation:

- (1) If the machine's oil pan has an oil sump, never operate the machine before filling it.
- (2) If the machine is lubricated by a drop oiler, never operate the machine before lubricating.
- (3) When a new sewing machine is first turned on, verify the rotational direction of the balance wheel with the power on. (The balance wheel should rotate counter-clockwise when viewed from the balance wheel)
- (4) Verify the voltage and (single or three) phase with those given on the machine nameplate.

3) Precautions for Operating Conditions:

- (1) Avoid using the machine at abnormally high temperature (35°C or higher) or low temperature (5°C or lower)
- (2) Avoid using the machine in dusty conditions.

2. MAIN SPECIFICATIONS

Item	GC2008-M	GC2008-MD
Material	Light	
Max.sewing speed	5000 rpm	
Stitch length	0-4mm	0-4mm
Needle bar stroke	31.8mm	
Presser	By hand	6mm
	By knee	13mm
Needle	DB×1 #14	
Reversing mechanism		○
Trimming mechanism		○
Touch back mechanism		○

3. PREPARATION AND LUBRICATION

1) Cleaning the machine

Before leaving the factory, the machine parts are coated with rust-preventive grease, which may be hardened and contaminated by dust during storage and shipment. This grease must be removed with gasoline.

2) Examination

Though every machine is confirmed by strict inspection and test before leaving the factory, the machine parts may be loose or deformed after long distance transportation with jolt. A thorough examination must be performed after cleaning the machine. Turn the balance wheel to see if there is running obstruction, parts collision, uneven resistance or abnormal noise. If these exist, adjustment must be made accordingly before run-in operation.

3) Oiling (Fig.1)

(1) Required amount of oil

Line (A) on the oil reservoir: Max. Oil level

Line (B) on the oil reservoir: Min. Oil level

If oil level goes down under line (B), oil cannot be distributed to each part of the machine, thus causing the parts a seizure.

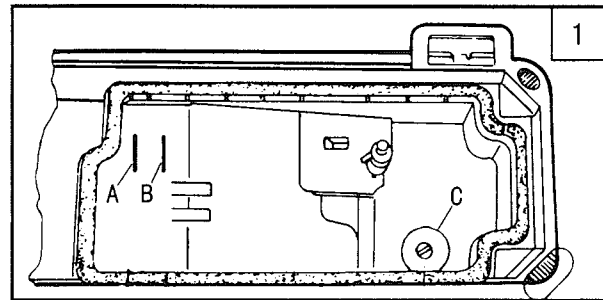

(2) Replenishing

Always use only No. 18 special machine oil for high speed sewing. Be sure to replenish oil to line (A) before starting operation.

(3) Replacing oil

To replace oil, remove screw (C) to drain oil. After completely draining off oil, clean the oil reservoir and securely tighten screw (C), then fill the reservoir with fresh oil.

4. REPLACE NEEDLES (Fig.2)

Turn the balance wheel to lift needle bar to the upper end of its stroke. Loosen needle clamp screw (A). While keeping the long groove of the needle leftward fully insert the needle shank up to the bottom of the needle socket. Then tighten needle clamp screw (A).

Note: Fig. (b): insufficient insertion.

Fig. (c): wrong direction of long groove.

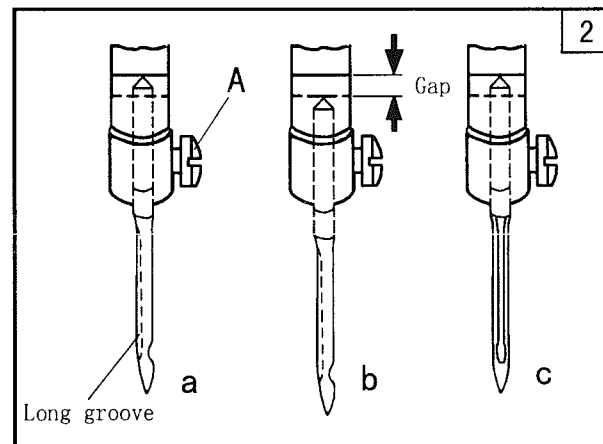

5. NEEDLE, THREAD AND MATERIAL TO BE SEWN

Needle Size	Thread Number	Material
No.9	No.100- No.80	crepe, georgette, organdie
No.11	No.80- No.60	silk, muslin, poplin
No.14	No.60- No.50	cotton, light, woolen
No.16	No.50- No.30	woolen, tarpaulin, thin leather

6. THREADING (Fig.3)

Raise the thread take-up lever to its highest position and thread the upper thread in the following order.

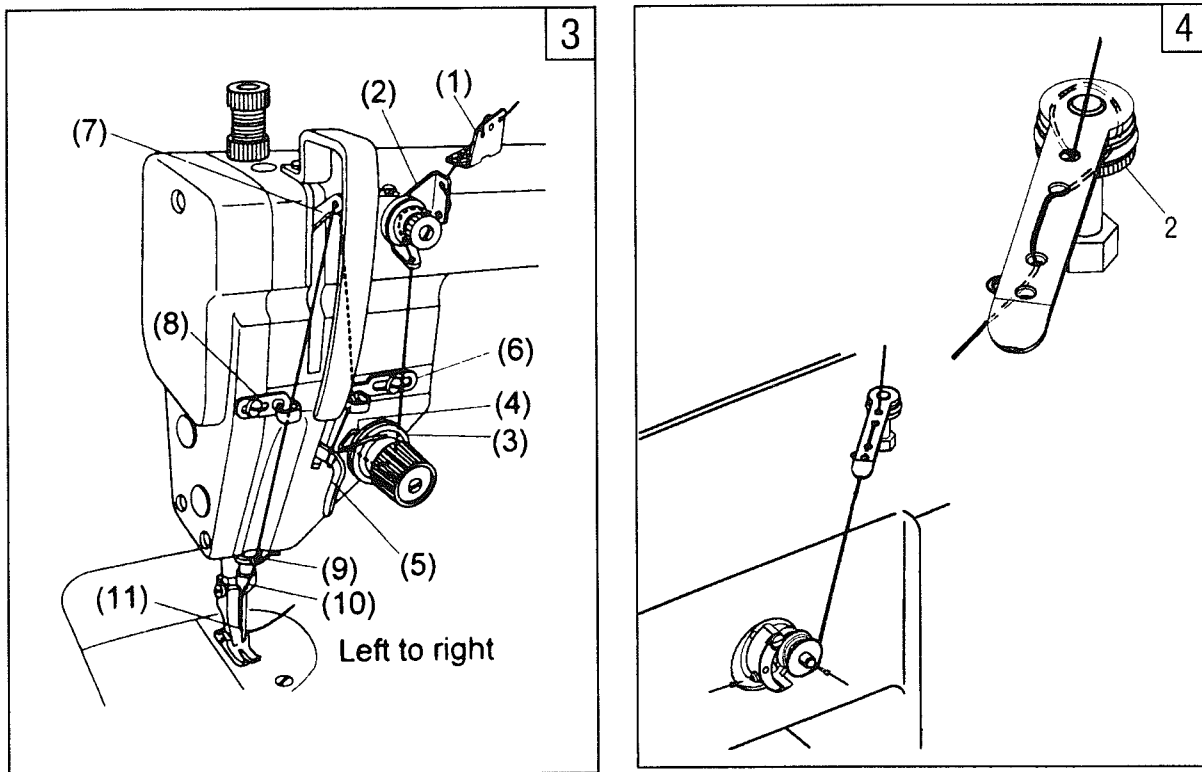

7. WINDING ADJUSTMENT (Fig.4)

- 1) Put an empty bobbin onto the bobbin shaft and thread the thread according to Fig 4
- 2) Push the bobbin catch in the direction of the arrow
- 3) The bobbin is filled during the progress of the sewing.
- 4) The bobbinet stops automatically when the bobbin is full.
- 5) The tension of the thread on the bobbin can be adjusted with knurl-screw 2.

8. SET STITCH LENGTH AND REVERSE FEEDING (Fig.5)

- 1) Stitch length can be set by turning dial (A).
- 2) The figures on face (B) of dial show stitch length in mm.
- 3) Reverse feeding starts when reverse feed lever (C) is depressed, and the machine will feed forward again

if reverse feed lever (C) is released.

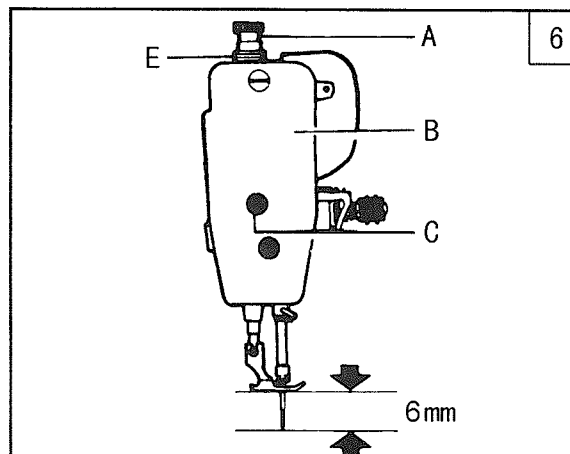
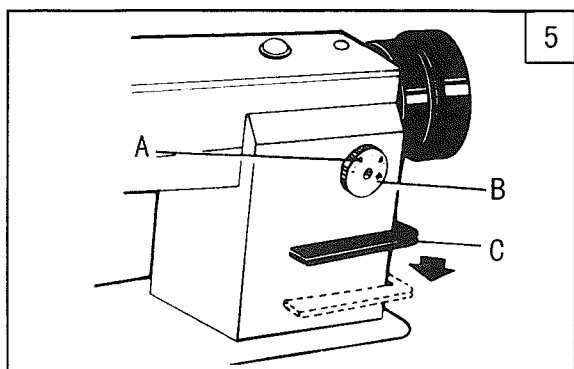

9. POSITION PRESSER BAR (Fig.6)

- 1) Loosen lock nut (E) and pressure regulating thumb screw (A).
- 2) Remove Rubber Plug from face plate (B).
- 3) Loosen screw (C) and adjust the position of Presser Bar till the presser foot is 6 mm above the throat plate will the presser foot lifted to its highest.
- 4) Tighten screw (C) and put in the rubber plug.
- 5) Tighten pressure regulating thumb screw (A) and lock nut (E).

10. ADJUST THE PRESSURE OF PRESSER FOOT (Fig.7)

Pressure of the presser foot can be adjusted by turning the pressure regulating thumb screw.

11. ADJUSTING OF UPPER THREAD TENSION (Fig.8)

- 1) Upper thread tension can be adjusted by thread tension nut.
- 2) Upper thread is to be adjusted according to the lower thread tension.
- 3) For special fabric sewing with special thread, the desired tension can be obtained by adjusting the strength and operating range of thread take-up spring.

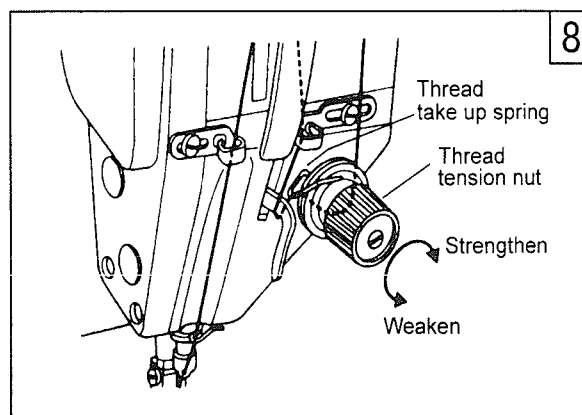
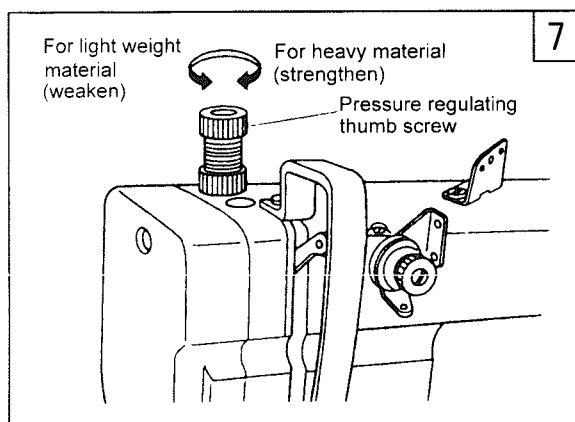

12. ADJUST THREAD TENSION

(Fig.9, 10)

1) Lower thread tension can be adjusted by screw (A).

2) In the case of cotton thread #60, the thread tension can be checked as the following. Hold the end of pulled out thread and if the bobbin case fall slowly, the tension is proper.

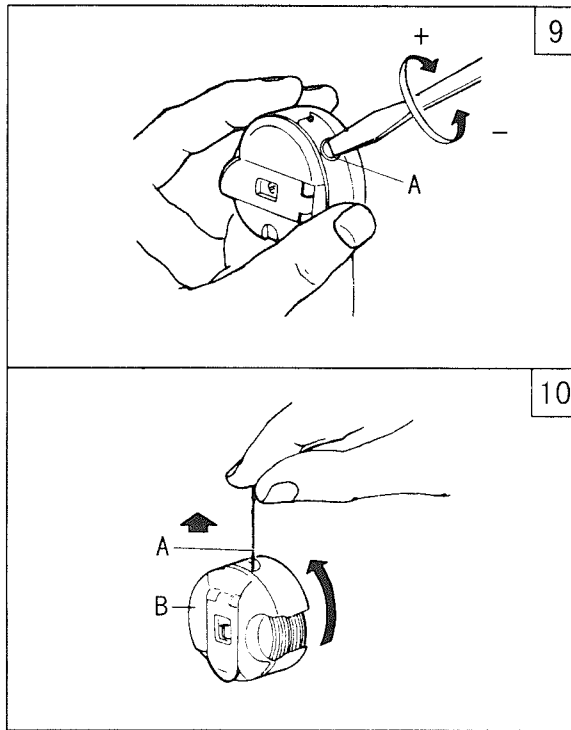

13. ADJUSTING OF THREAD TENSION

TENSION (Fig.11)

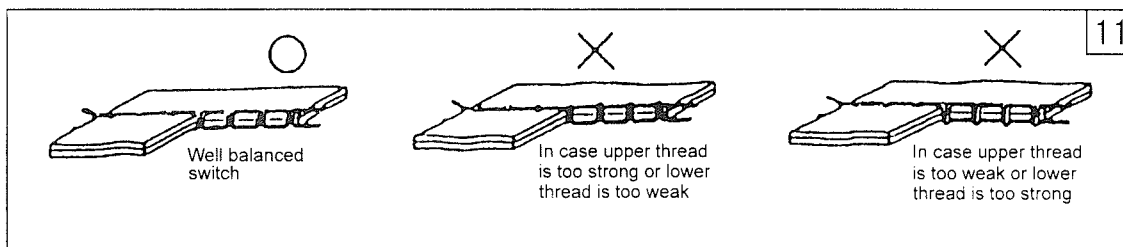

14. ADJUSTING OF THE THREAD GUIDE

The position of the thread guide affects stitch tightness and therefore must be adjusted according to sewing materials and sewing conditions.

	1	2	3
Thread guide position	Leftward	Center	Rightward
Material weight	Heavy	Medium	Light

15. TIME NEEDLE TO ROTATING HOOK (Fig. 12, 13, 14, 15)

1) Adjusting the needle position (Fig.12, 13)

- (1) Turn balance wheel by hand to bring needle bar (C) to the lowest position of its stroke.
- (2) Remove rubber plug from face plate (A).
- (3) Loosen set screw (B) of needle bar adaptor.
- (4) Move needle bar (C) vertically to adjust needle timing.

(5) After the adjustment, tighten set screw (B) and put in the rubber plug. The standard needle timing (Fig.13) is to align timing mark (B) on the needle bar and the bottom of needle bar bushing (A) and meanwhile align the inner surface (E) of the hook and the center of needle eye (D) when the needle bar gets down to its lowest position.

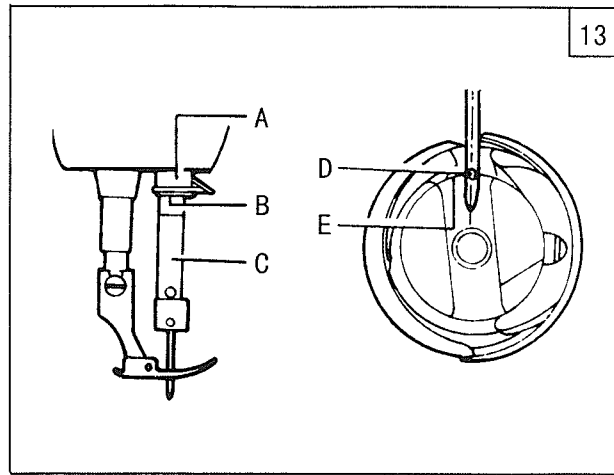
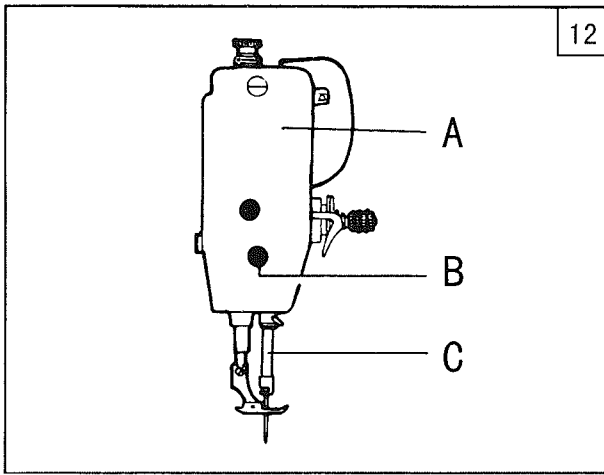

2) Adjusting the hook point timing (Fig.14, 15)

Timing of needle motion to rotating hook motion has a great effect on sewing performance. The standard hook point timing (Fig.14) is to align hook point (D) and needle centerline (C) when needle bar (B) is lifted by 2.2mm from the lower end of its stroke. Besides, hook point (D) should be 1.0-1.5mm above the upper end of needle eye (E).

When adjusting the hook point timing, also notice that the clearance between the bottom of needle notch and hook point (C) should be approx. 0.05mm (Fig.15)

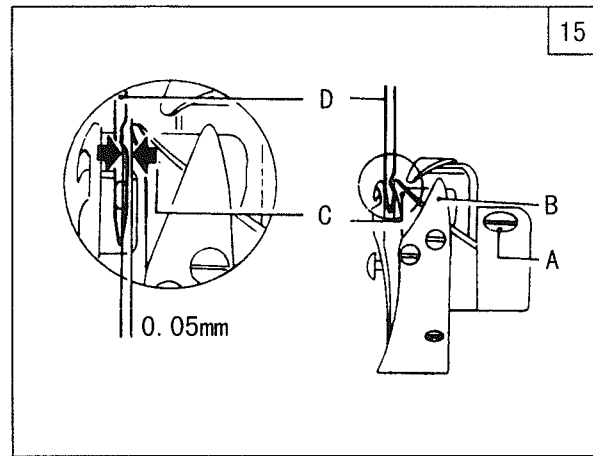
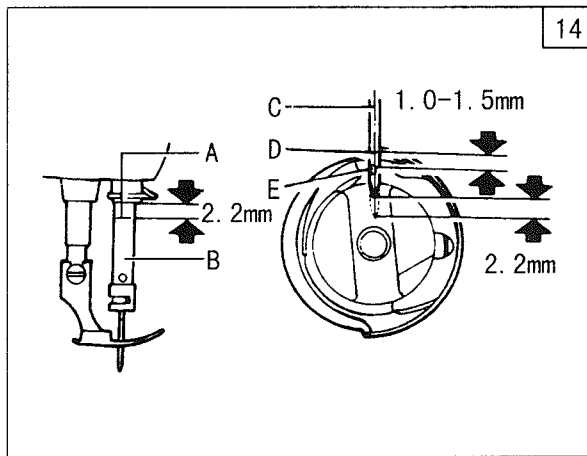

16. REPLACE ROTATING HOOK

(Fig.16)

- 1) Lift needle bar to the highest position of its stroke.
- 2) Remove throat plate, take down needle and bobbin case.
- 3) Loosen screw (C) of hook positioner and take down hook positioner (A).
- 4) Loosen two screw (D) of rotating hook.

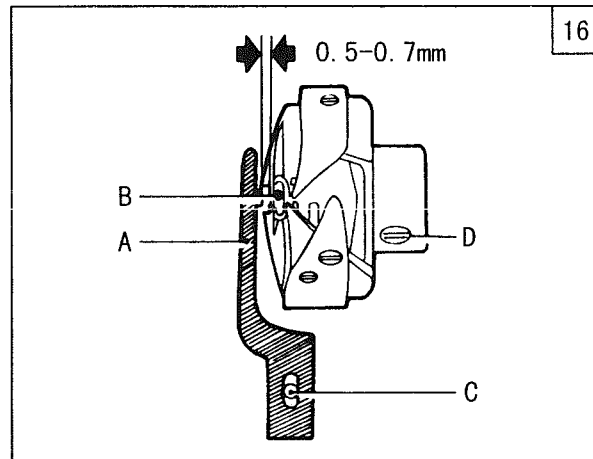

5) Turn the balance wheel to raise feed bar to its highest position, then take down the rotating hook by turning it away from feed bar.

6) Installing the hook can be done in reverse sequence. Note that needle (B) and the convex surface of hook positioner (A) should align with a clearance of 0.5-0.7mm between them.

17. ADJUST THE HEIGHT OF FEED DOG (Fig.17, 18)

- 1) Turn the balance wheel until feed dog is lifted to its highest position from throat plate surface.
- 2) Loosen screw (A) of feed lifting rock shaft crank right (See Fig.17, b)
- 3) Move feed bar (B) in the direction shown by the arrow in Fig.19 (a) to adjust the height of the feed dog. The standard height of feed dog is that the top of feed dog is 0.8mm above throat plate surface (B). (See Fig.18)
- 4) After the adjustment, be sure to tighten screw (A).

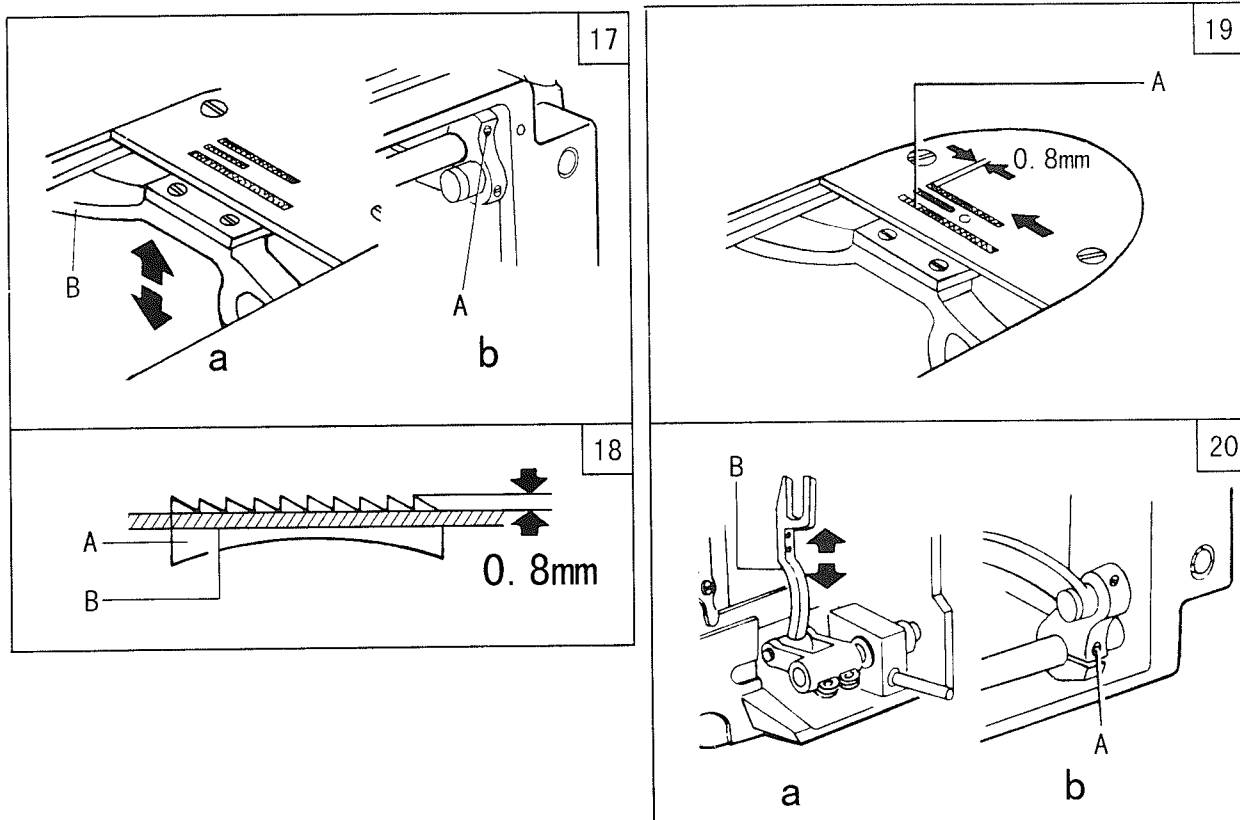

18. ADJUST THE POSITION OF FEED DOG (Fig.19, 20)

The standard position of feed dog is that the clearance between the front end of the throat plate slot and the first tooth of the fully advanced feed dog is 0.8 mm, as shown in Fig.19.

- 1) Fully advance the feed dog toward the front end of the throat plate slot.
- 2) Loosen feed rock shaft crank screw (A). See Fig.20 (b).
- 3) Move feed bar (B) in the direction shown by the arrow in Fig. 20 (a) to adjust the feed dog position.
- 4) After the adjustment, be sure to tighten Screw (A).

19. TIME FEED MOTION TO NEEDLE MOTION (Fig.21, 22)

The standard timing of feed motion to needle motion is that the top of feed dog (C) is flush with throat plate surface (B) when the point of needle (A) reaches throat plate surface (B). (Fig.21.)

If feed motion is not timed to needle motion, adjust as follows (Fig.21 and Fig.22).

1) Remove arm side cover (F).

2) Loosen set screws (A) and (D) of feed and feed lifting eccentric.

3) Hold feed and feed lifting eccentric (B) and turn balance wheel (E) slowly until the upper edge of arm shaft oil hole (C) aligns with the lower edge of reference hole (G) of feed and feed lifting eccentric.

4) Leave a clearance of 0.3-0.5mm between feed and feed lifting eccentric (B) and eccentric sleeve (H), then tighten set screws (A) and (D).

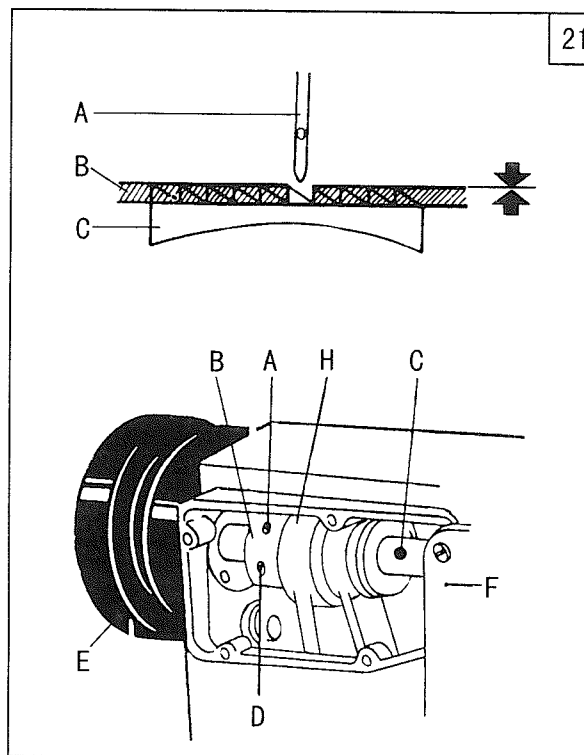
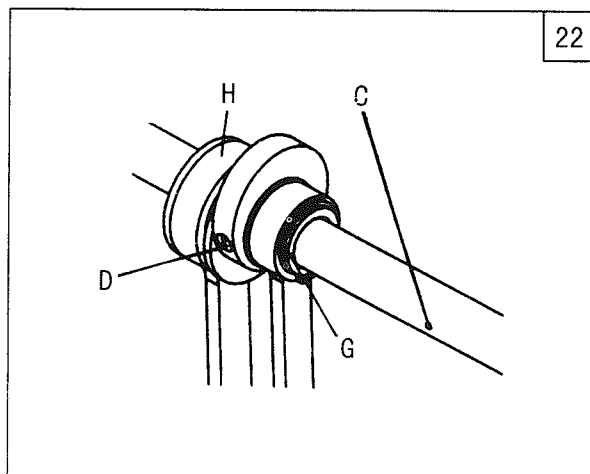

20. LUBRICATION ADJUSTMENT (Fig.23)

Adjusting the lubrication of rotating hook.

Oil adjusting screw (A) can adjust the lubrication of the rotating hook as follows:

1) Turn oil adjusting screw (A) clockwise to increase oil and turn oil adjusting screw (A) counter-clockwise to decrease oil.

2) Oil adjusting screw (A) adjusts oil amount within 5 turns. When oil adjusting screw (A) is fully tightened, oil amount is maximum.

3) Readjustment depends on temperature, sewing speed and the like. In practice, oil amount can be judged as follows: remove the throat plate and place a piece of paper on instead, run the machine for about 20 seconds, then check the oil splashed on the paper.

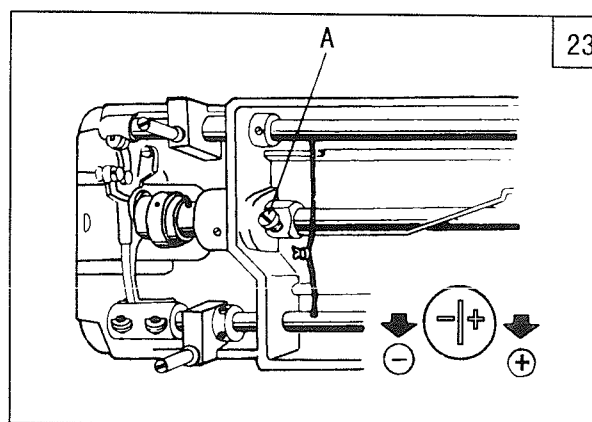

21. REGULAR CLEANING (Fig.24)

1) Cleaning feed dog

Remove the throat plate and clear off the dust and lint between feed dog tooth slots.

2) Cleaning rotating hook

Swing out the machine head and clean the hook. Wipe the bobbin case with soft cloth.

3) Cleaning oil pump, screen

Swing out the machine head and clear off the dust and dirt on oil pump screen.

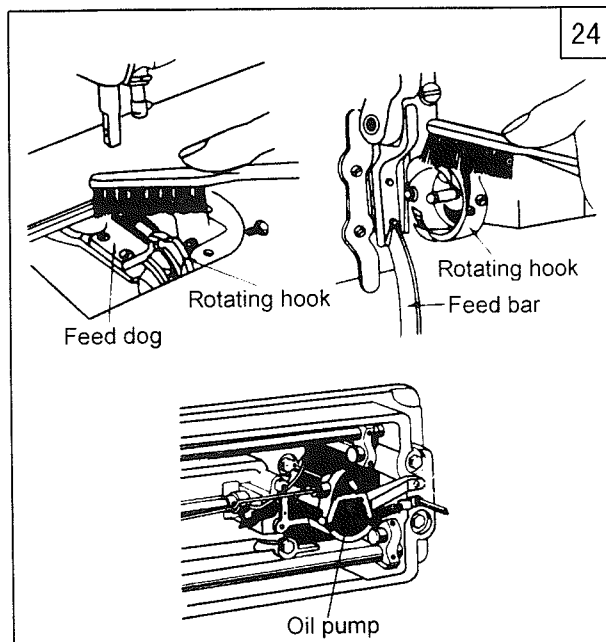

SPECIAL INSTRUCTION OF GC2008-MD

22. ADJUSTMENT OF NEEDLE BAR

STOP POSITION (Fig. 25, 26)

1) Adjusting of "UP" position

When the pedal is kicked down by heel, the machine stops at "UP" position. If the marks deviate larger than 3 mm adjust as follows:

- (1) Disconnect the plug (12 pins) of cable from the machine head.
- (2) Run the machine and stop at "UP" position.
- (3) While holding the balance wheel insert the "adjusting tool" in the hole A, then remove the tool.

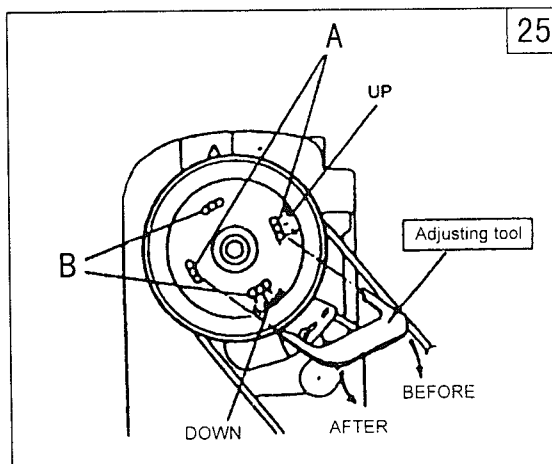

2) Adjusting of "DOWN" position

Set the machine stops at "DOWN" position. When the pedal is kicked down by hell, the machine stops as "DOWN" position. If the marks deviate larger than 3 mm adjust as follows:

- (1) Disconnect the plug (12 pins) of cable from the machine head.
- (2) Run the machine and stop at "DOWN" position.
- (3) While holding the balance wheel insert the

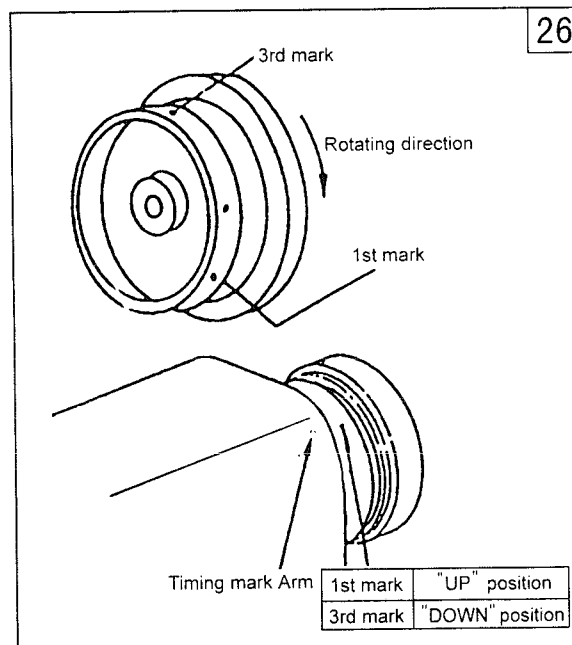

“adjusting tool” in the hole B, then remove the tool.

- 3) Confirm the stop operation then the plug (12 pins) coming from the machine head into the receptacle.

23. REVERSE SEWING (Fig.27)

While sewing, depressing the button switch, it becomes reverse sewing.

24. THREAD WIPER (Fig.28)

When the thread wiper is operated, the end of upper thread does not remain on the surface of fabric.

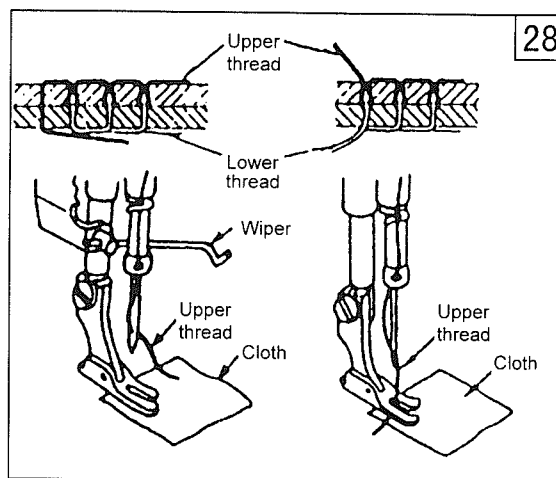
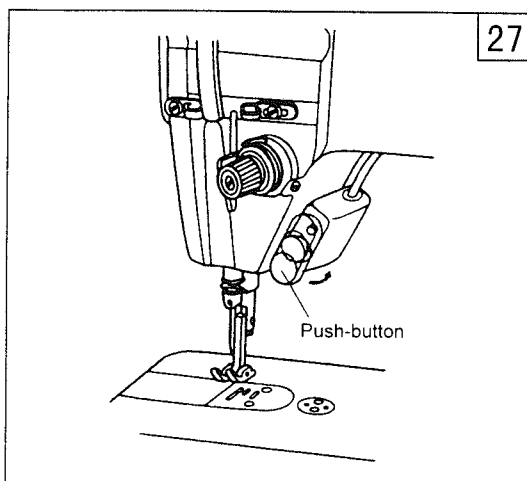

25. ADJUSTMENT OF KNIFE ENGAGEMENT(Fig.29,30,31,32)

1) Position of fixed knife

(1) As a standard, the dimension between the fixed knife's end and the needle center is 2.5mm. (Fig.29)

(2) The standard relation of the knife (left) and fixed knife is shown in the figure. As a standard, Dimension A is 0.3mm. (Fig.30)

(3) When Dimension A is too large, the three piece of threads will be cut, and can cause the needle thread to come out from needle after trimming. If too small, the thread may not be trimmed correctly.

(4) Adjust by adjusting the installation of the fixed knife.

2) Knife engagement amount

(1) When the sewing machine is rotated while the solenoid is activated, the knife (left) will be rotated by the thread trimming cam. As a standard, the knife

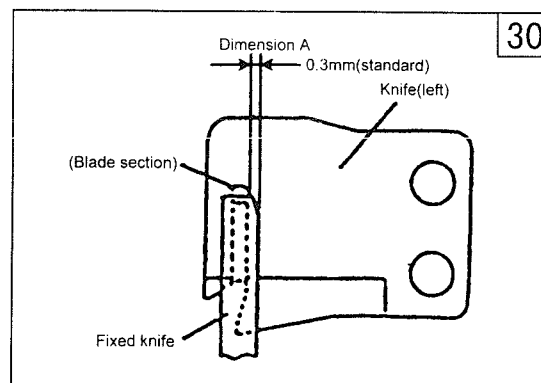
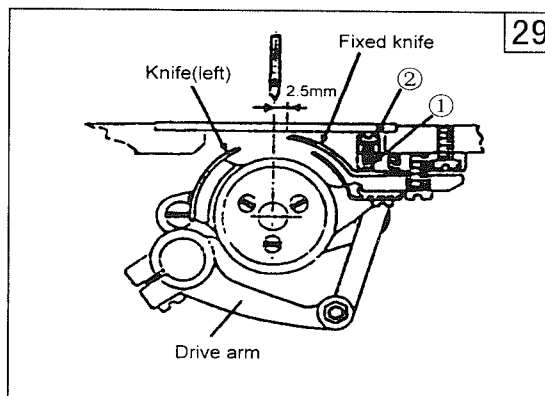

engagement amount should be 1.5 to 2.0mm when the knife (left) moves the most. (Fig.31)

(2) Adjust by adjusting the installation of the drive arm.

3) Adjustment of knife engagement pressure

(1) As a standard, the knife (left) and fixed knife should start contacting at the position shown in the figure. (Fig.32)

(2) To adjust the engagement pressure, loosen the lock nut ② and then adjust the adjustment screw ①.

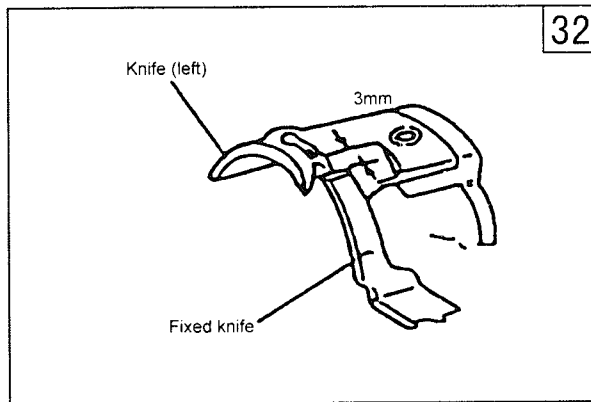
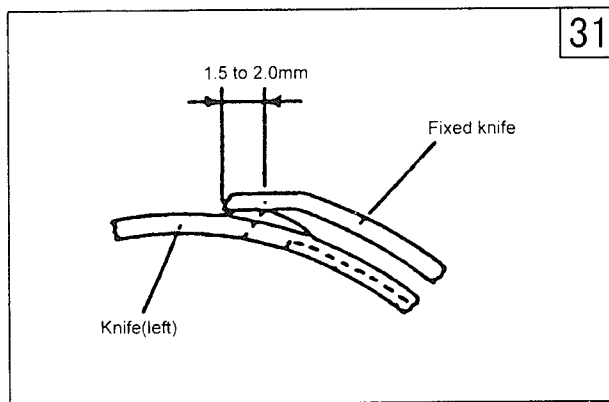

A.ARM BED AND ITS ACCESSORIES

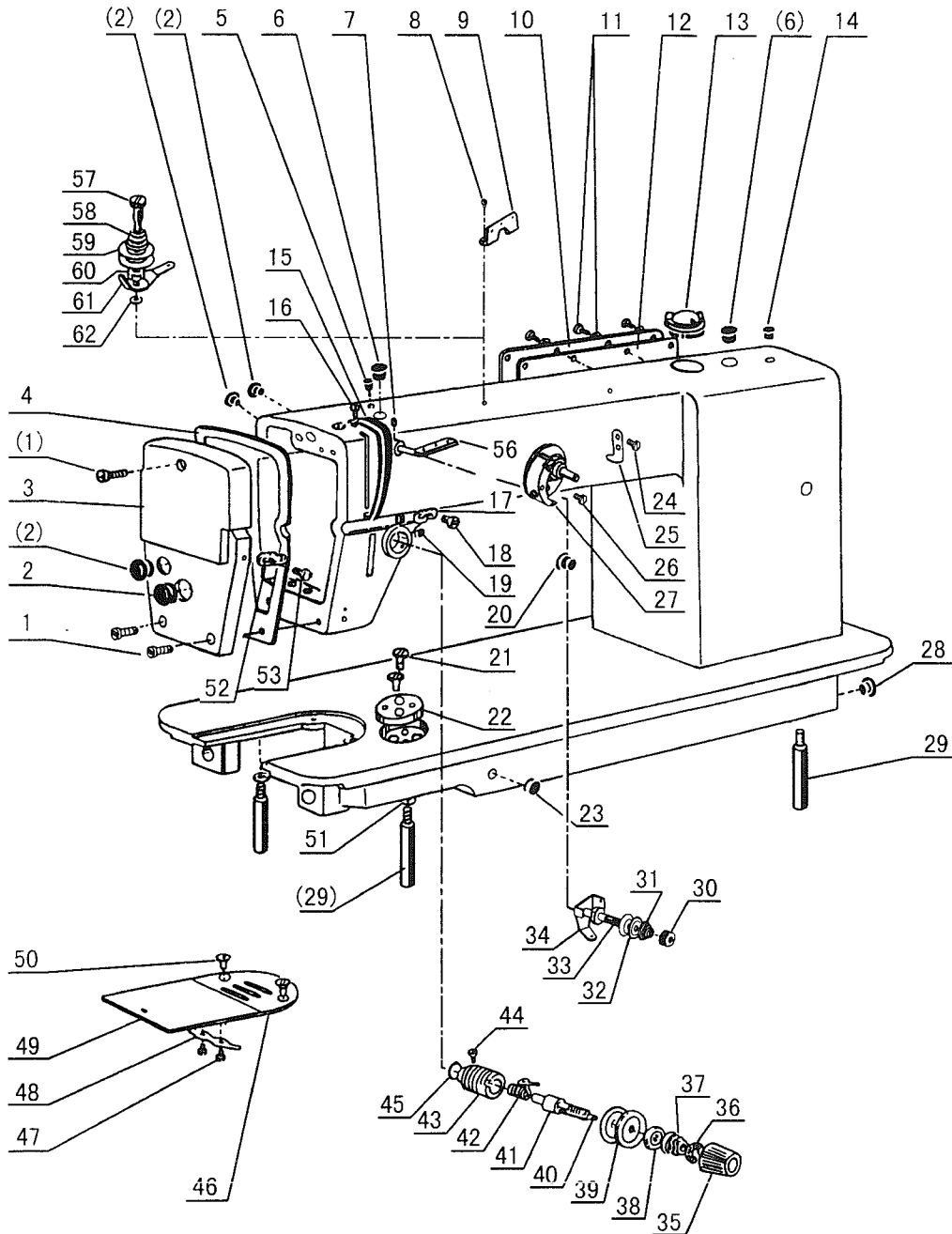

A.ARM BED AND ITS ACCESSORIES

Fig. No.	Part No.	Description	M D	M	Remarks
A01	HA300B2160	Screw	3	3	SM11/64(40)×10
A02	HA307B0674	Rubber plug Φ11.8	4	4	
A03	HB2260B081	Face plate	1	1	
A04	H6722B8001	Casket for face plate	1	1	
A05	HA300B2090	Rubber plug Φ8.8	1	1	
A06	HA307B0673	Rubber plug Φ19	2	2	
A07	HA100B2110	Set screw	1	1	
A08	HA700B2060	Screw	1		
A09	HA700B2050	Thread guide (arm top)	1		
A10	HG611B8001	Arm side cover	1	1	
A11	HA300B2170	Screw	11	11	
A12	HG612B8001	Gasket for arm side cover	1	1	
A13	H1210B0671	Oil check window	1	1	
A14	HA300B2110	Rubber plug Φ5.7	1	1	
A15	HB22511081	Thread take-up cover	1	1	
A16	HA300C2030	Screw	1	1	SM11/64(40)·8
A17	HA100B2140	Thread guide	1	1	
A18	HA106B0676	Screw 9/64(40)×6	1	1	SM9/64(40)·6
A19	HA300B2080	Set screw 15/64(28)×6	1	1	SM15/64(28)·6
A20	HA300B2090	Rubber plug Φ8.8	1	1	
A21	HA300B2130	Screw	2	2	SM11/64(40)·5.5
A22	HA300B2140	Plate for guide	1	1	
A23	HA307B0674	Rubber plug Φ11.8	1	1	
A24	H6762B8001	Screw 9/64(40)×4.5	2	2	SM9/64(40)·4.5
A25	H6756B8001	Thread cutter	1	1	
A26	H7322B8001	Screw	1	1	M4×6
A27	H7325D7101	Bobbin winder complete	1	1	
A28	HA300B2100	Rubber plug Φ27	1	1	
A29	HA100B2220	Leg	3	3	
A30	HA710B0671	Nut	1		SM11/64(40)
A31	HA710B0672	Pre-tension spring	1		
A32	HA112B0693	Thread tension discs	2		
A33	HA710B0673	Thread tension stud	1		
A34	HA710B0674	Thread guide	1		
A35	HA310B0701	Thumb nut	1	1	
A36	HA115B7010	Thumb net revolution stopper	1	1	
A37	HA115B0703	Thread tension spring	1	1	
A38	HA310B0702	Thread tension releasing discs	1	1	
A39	HA310B0705	Thread tension discs	2	2	
A40	H6725B8001	Thread tension releasing pin	1	1	
A41	HA115B0701	Thread tension stud	1	1	
A42	HA115B0706	Thread take-up spring	1	1	
A43	HA310B0703	Thread tension regulator bushing	1	1	

A.ARM BED AND ITS ACCESSORIES

Fig. No.	Part No.	Description	M D	M	Remarks
A44	HA115B0708	Screw	1	1	SM9/64(40)×4
A45	HA115B7011	O-ring	1	1	
A46	HA700B2100	Needle plate	1	1	
A47	HA124B0713	Screw	2	2	SM3/32(56)×2.4
A48	HA324B0711	Spring for slide plate	1	1	
A49	HA124B0711	Slide Plate	1	1	
A50	HA300B2190	Screw	2	2	SM11/64(40)×8
A51	H005008060	Spring washer	3	3	
A52	HA106B0675	Thread guide	1	1	
A53	HA106B0676	Screw	1	1	SM9/64(40)×6
A56	HA100B2100	Three-hole thread guide		1	
A57	HA112B0691	Screw type tension stud		1	
A58	HA112B0692	Spring for pre-tension		1	
A59	HA112B0693	Disk for pre-tension		2	
A60	HA112B0694	Space for pre-tension		1	
A61	HA112B0695	Pre-tension thread guide		1	
A62	H007013030	Stop ring		1	

B.NEEDLE BAR AND THREAD TAKE-UP MECHANISM

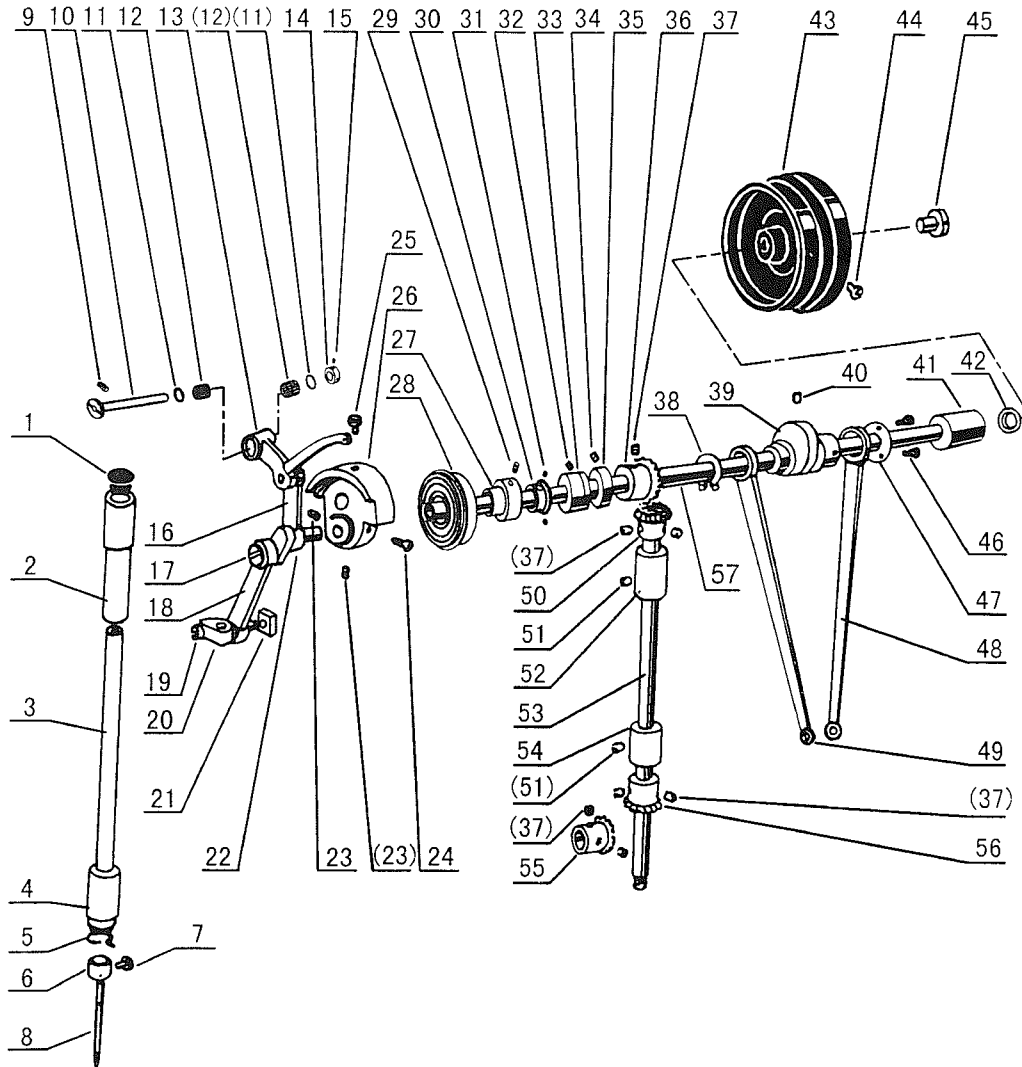

B.NEEDLE BAR AND THREAD TAKE-UP MECHANISM

Fig. No.	Part No.	Description	M D	M	Remarks
B01	HA300B2090	Rubber plug ϕ 8.8	1	1	
B02	H6711B8001	Needle bar bushing (upper)	1	1	
B03	HA705G0066	Needle bar	1	1	
B04	H6734B8001	Needle bar busing (lower)	1	1	
B05	HA300C2070	Thread guide	1	1	
B06	HA100C2150	Thread guide	1	1	
B07	HA100C2170	Screw	1	1	SM1/8(44) \times 4.5
B08	HA100C2160	Needle DB \times 1-2-14	1	1	
B09	HA100C2020	Set screw	1	1	SM15/64(28) \times 10
B10	H6716I8001	Thread take-up support shaft	1	1	
B11	H6718I8001	Bearing support	2	2	
B12	H6717I8001	Needle bearing	2	2	
B13	H6710I8001	Thread take-up lever link	1	1	
B14	H6719I8001	Thrust collar	1	1	
B15	HA100B2110	Set screw	2	2	SM11/64(40) \times 5.5
B16	HB2254I072	Thread take-up lever	1	1	
B17	H6715I8001	Set screw (left-handed)	1	1	
B18	HB2255I072	Needle bar link	1	1	
B19	H2204C0651	Screw	1	1	
B20	HA104C0658	Needle bar holder	1	1	
B21	H6704H8001	Square block	1	1	
B22	H6711I8001	Thread take-up crank	1	1	
B23	HA307C0662	Set screw	2	2	SM1/4(40) \times 5
B24	HA100C2060	Screw	1	1	SM9/32(28) \times 13
B25	HA100C2070	Screw	1	1	SM9/32(28) \times 14
B26	H6706C8001	Crank	1	1	
B27	H6711C8001	Bushing	1	1	
B28	H3208H0661	Ball bearing	1	1	
B29	H431060080	Socket set screw	2	2	M6 \times 8
B30	H7324D8001	Bobbin winder driving wheel	1	1	
B31	HA108C0662	Socket set screw	2	2	SM1/4(40) \times 5
B32	HG609C7101	Arm shaft bushing (middle)	1	1	
B33	HA100C2020	Set screw	1	1	SM15/64(28) \times 10
B34	HA108G0661	Collar for arm shaft	1	1	
B35	HA105D0662	Set screw	2	2	SM1/4(40) \times 4
B36	HA113B2112	Bevel gear for arm shaft	1	1	
B37	HA108C0663	Set screw	8	8	
B38	HA112D3012	Stop ring	1	1	
B39	HA7311C106	Feed and feed lifting eccentric	1	1	
B40	HA100C2020	Set screw	2	2	SM15/64(28) \times 10
B41	HA300D2020	Arm shaft bushing(right)	1	1	
B42	HA306D0066	Oil seal	1	1	
B43	HA710R0651	Balance wheel	1		

B.NEEDLE BAR AND THREAD TAKE-UP MECHANISM

Fig. No.	Part No.	Description	M D	M	Remarks
B43	HA110D0671	Balance wheel		1	
B44	HA110D0672	Set screw	2	2	SM15/64(28)×12
B45	HA100D2080	Screw	1	1	SM11/32(28)×10
B46	HA7311C306	Set screw	3	3	SM9/64(40)×7
B47	HA7311C206	Washer	1	1	
B48	HG611C8001	Crank rod for feed rock shaft	1	1	
B49	HA112D3013	Crank rod for feed lifting rock shaft	1	1	
B50	HA113D2122	Bevel gear for vertical shaft(upper)	1	1	
B51	HA100C2020	Set screw	2	2	SM15/64(28)×10
B52	HA100D2110	Vertical shaft bushing(upper)	1	1	
B53	HA113D0691	Vertical shaft	1	1	
B54	HA100D2110	Vertical shaft bushing(lower)	1	1	
B55	HA113D2212	Bevel gear for hook shaft	1	1	
B56	HA113D2222	Bevel gear for vertical shaft(lower)	1	1	
B57	HG605C8001	Upper shaft	1	1	

C.FEEDING AND FEED LIFTING & LOWER SHAFT MECHANISM

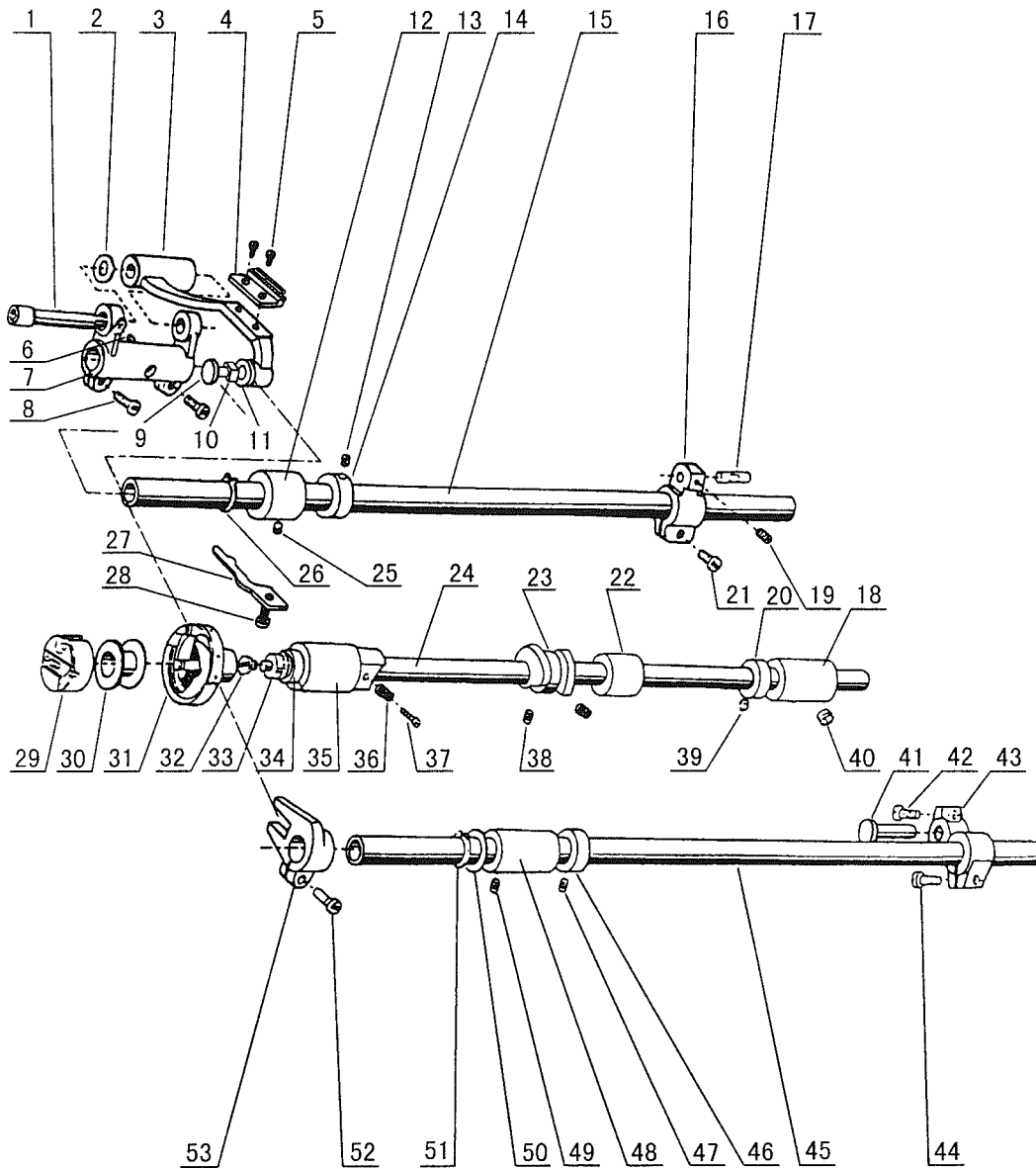

C.FEEDING AND FEED LIFTING & LOWER SHAFT MECHANISM

Fig. No.	Part No.	Description	M D	M	Remarks
C01	HA705J0654	Shaft for feed bar(eccentric)	1	1	
C02	HA104G0656	Washer	1	1	
C03	HA713J1105	Feed bar	1	1	
C04	HA104G0653	Feed dog	1	1	
C05	HA104G0654	Screw	2	2	SM1/8(44)×6
C06	HA100C2190	Screw	1	1	SM11/64(40)×8
C07	HA104G0011	Feed rock shaft crank	1	1	
C08	HA104G0012	Screw	2	2	SM3/16(28)×12
C09	HA305G1012	Hinge pin for slide block	1	1	
C10	HA310G3011	Slide block	1	1	
C11	HA310G3012	Washer	1	1	
C12	HA100G2040	Feed rock shaft bushing	1	1	
C13	HA105D0662	Set screw	2	2	SM1/4(40)×4
C14	HA108G0661	Collar	1	1	
C15	HA300G2050	Feed rock shaft	1	1	
C16	HA7311C706	Feed rock shaft crank(right)	1	1	
C17	HA706C11B1	Feed rock shaft crank pin	1	1	
C18	HA311E0671	Hook shaft bushing(right)	1	1	
C19	HA7311C806	Screw	1	1	SM11/64(40)×7
C20	HA305E0661	Collar for rotating hook shaft	1	1	
C21	HA7311C606	Screw	1	1	SM11/64(40)×15
C22	HA704B0653	Hook shaft bushing(middle)	1		
C23	HA710E0691	Thread trimming eccentric	1		
C24	HA704E0651	Rotating hook shaft	1	1	
C25	HA305E0662	Set screw	1	1	SM15/64(28)×4.5
C26	H007009150	Stop ring	1	1	
C27	HA300E2050	Rotating hook positioner	1	1	
C28	HA100E2150	Screw	1	1	SM11/64(40)×10
C29	HA119E0070	Bobbin case	1	1	
C30	H2604D8001	Bobbin	1		
C30	HA100E2170	Bobbin		1	
C31	HA707E0067	Rotating hook complete	1		
C31	HA115E0069	Rotating hook complete		1	
C32	HA111E104	Filter screw	1	1	SM3/16(32)×9
C33	HA111E204	Filter	1	1	
C34	HA700E2030	Oil seal for rotating hook shaft	1		
C34	HA106E0071	Oil seal for rotating hook shaft		1	
C35	HA704B0654	Hook shaft bushing(left)	1		
C35	HA100E2040	Hook shaft bushing(left)		1	
C36	HA100E2060	Spring for oil adjusting	1	1	
C37	HA300E2030	Oil adjusting screw	1	1	
C38	HA710E0692	Set screw	2		SM1/4(40)×10
C39	HA305E0662	Set screw	2	2	SM15/64(28)×4.5

C.FEEDING AND FEED LIFTING & LOWER SHAFT MECHANISM

Fig. No.	Part No.	Description	M D	M	Remarks
C40	HA100C2020	Set screw	1	1	SM15/64(28)×10
C41	HA100G2070	Hinge pin	1	1	
C42	HA104G0012	Screw	2	2	SM3/16(28)×12
C43	HA705K0661	Feed lifting rock shaft crank(right)	1	1	
C44	HA104G0012	Screw	2	2	SM3/16(28)×12
C45	HA704K0652	Feed lifting rock shaft	1	1	
C46	HA108G0661	Collar for feed lifting rock shaft	1	1	
C47	HA105D0662	Set screw	2	2	SM1/4(40)×4
C48	HA100G2120	Feed lifting rock shaft bushing	1	1	
C49	HA100C2020	Set screw	1	1	SM15/64(28)×10
C50	HA100G2130	Washer	1	1	
C51	H007009150	Stop ring	1	1	
C52	HA111G0683	Screw	1	1	SM11/64(40)×12
C53	H1204D0651	Feed lifting rock shaft crank(left)	1	1	

D.STITCH REGULATOR MECHANISM

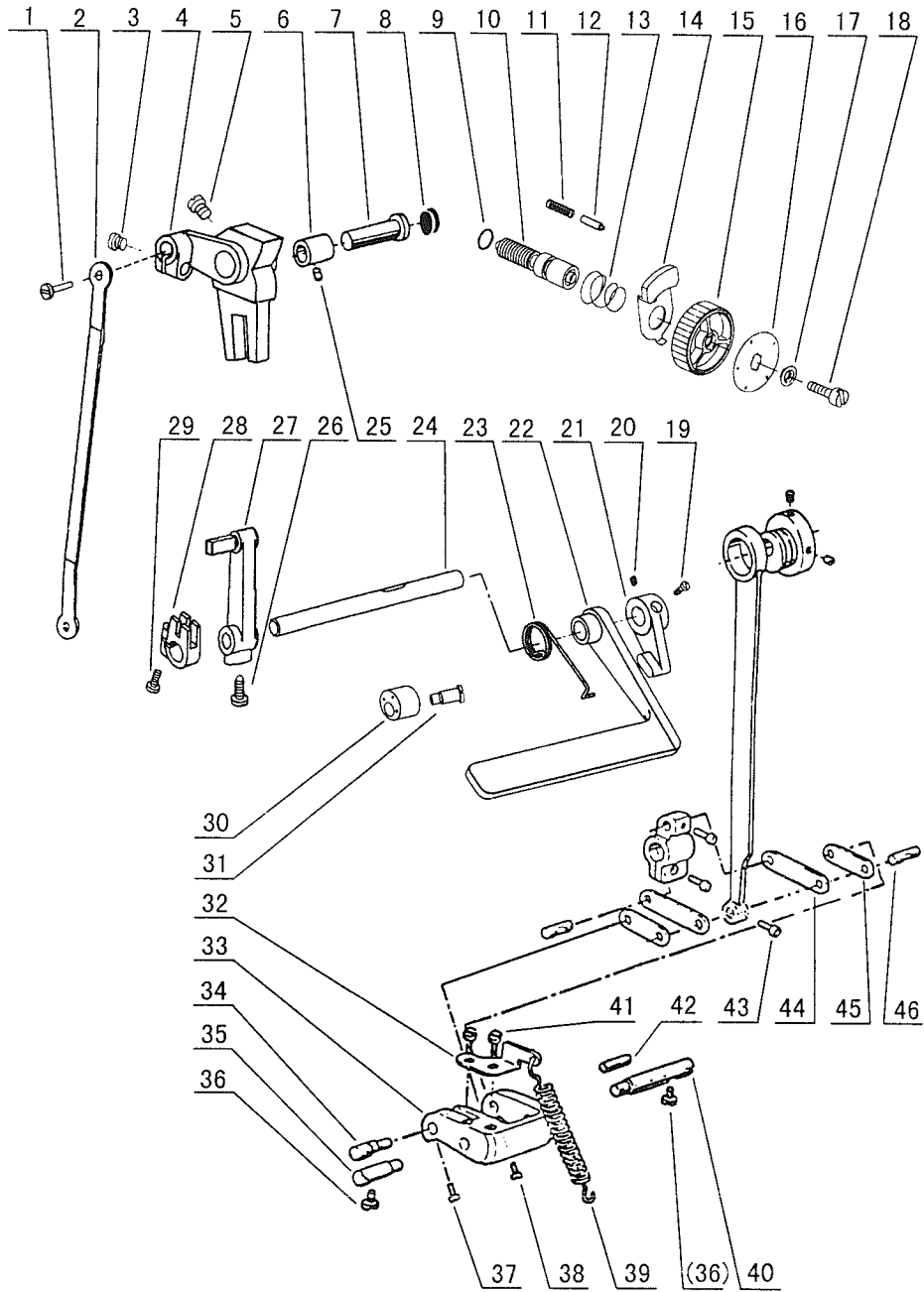

D.STITCH REGULATOR MECHANISM

Fig. No.	Part No.	Description	M D	M	Remarks
D01	HA700C2060	Connecting rod stud	1	1	
D02	HG606E8001	Feed regulating link	1	1	
D03	HA111G0683	Screw	1	1	SM11/64(40)×12
D04	HG605E8001	Feed regulator	1	1	
D05	HA104F0654	Screw	1	1	SM15/64(28)×10
D06	HA704B0655	Feed regulator bushing	1	1	
D07	HA100F2040	Hinge pin for feed regulator	1	1	
D08	HA700B2120	Rubber plug(Φ 20×6)	1	1	
D09	HA109F0674	O-ring	1	1	
D10	HA720F0681	Screw bar	1	1	
D11	HA100F2090	Spring	1	1	
D12	HA700F2030	Stopper pin	1	1	
D13	HA720F0687	Coil spring	1	1	
D14	HA720F0683	Releasing lever	1	1	
D15	HA7421F120	Dial for stitch length regulator	1	1	
D16	H8504H8001	Stitch length indicating plate	1	1	
D17	HA720F0685	Bushing	1	1	
D18	HA720F0686	Screw	1	1	SM3/16(28)×12
D19	HA3411D308	Screw	1	1	SM15/64(28)×7
D20	HA113F0684	Screw	1	1	SM15/64(28)×8.5
D21	H4936L8001	Lever	1	1	
D22	HB2258G081	Reverse lever	1	1	
D23	H4939L8001	Spring	1	1	
D24	HG607E8001	Reverse lever shaft	1	1	
D25	HA100C2020	Screw	1	1	SM15/64(28)×10
D26	H3200F2020	Screw	1	1	SM15/64(28)×12
D27	HG608E7101	Reverse crank complete	1	1	
D28	HG610E8001	Crank	1		
D29	HG611E8001	Screw	1		SM3/16(32)×14
D30	H4938L8001	Rubber ring Φ 16	1	1	
D31	H4937L8001	Screw	1	1	SM15/64(28)×6
D32	HA7311CI06	Spring holder	1	1	
D33	HA7311CG06	Stitch length adjusting crank	1	1	
D34	HA7311CF06	Link stud	1	1	
D35	HA700C2050	Feed regulator shaft(left)	1	1	
D36	HA111G0683	Screw	2	2	SM11/64(40)×12
D37	HA7311CC06	Screw	1	1	SM9/64(40)×6
D38	HA7311CD06	Screw	1	1	SM9/64(40)×8.5
D39	HA7311CJ06	Coil spring	1	1	
D40	HA700C2040	Feed regulator shaft(right)	1	1	
D41	HA7311CH06	Screw	2	2	SM9/64(40)×8
D42	HA7311CE06	Link stud	1	1	
D43	HA7311C806	Set screw	1	1	SM11/64(40)×7

D.STITCH REGULATOR MECHANISM

Fig. No.	Part No.	Description	M D	M	Remarks
D44	HA706C1192	Link(long)	2	2	
D45	HA706C1191	Link(short)	2	2	
D46	HA706C11B2	Link stud	1	1	

E.PRESSER FOOT MECHANISM

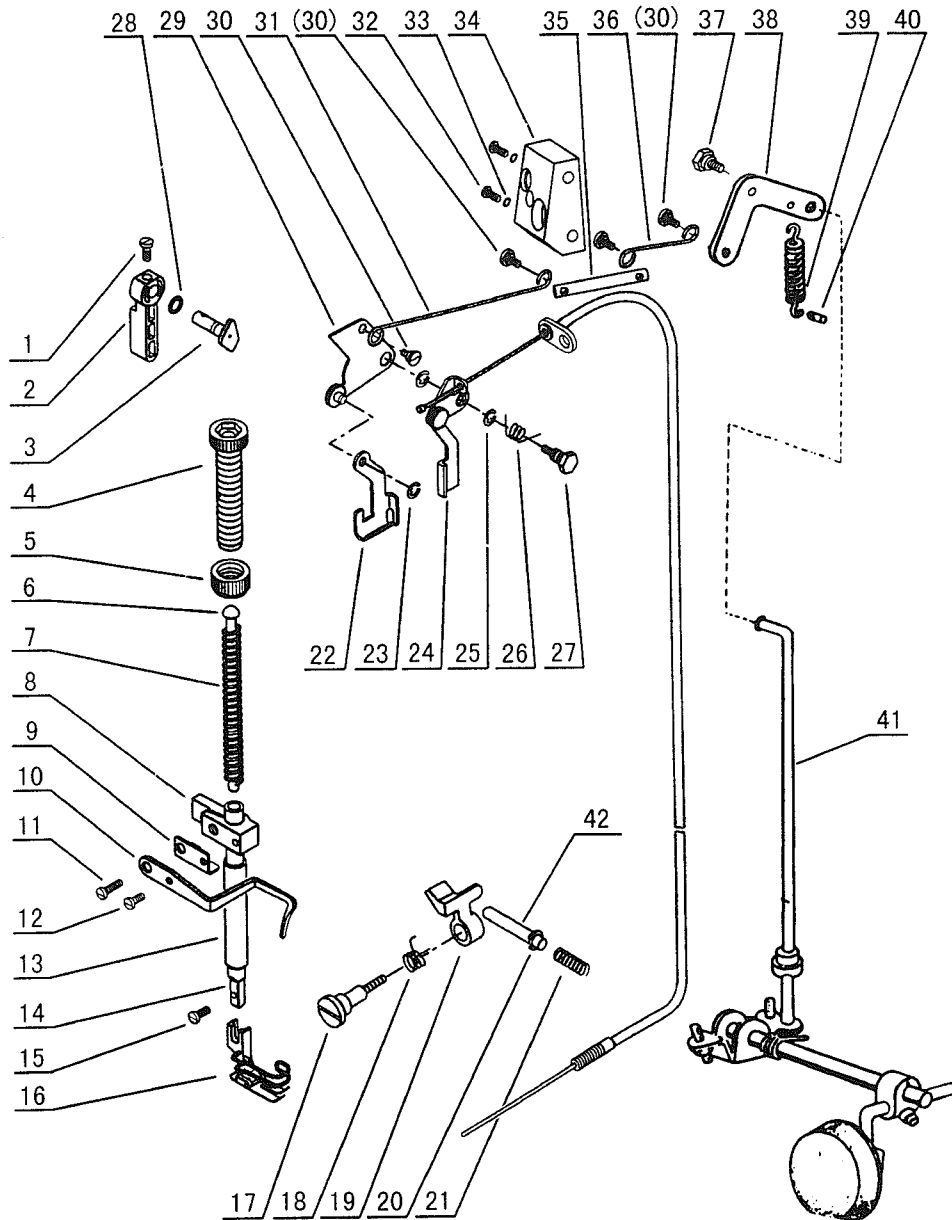

E.PRESSER FOOT MECHANISM

Fig. No.	Part No.	Description	M D	M	Remarks
E01	HA300B2170	Screw 11/64(40)×8.2	1	1	SM11/64(40)×8.2
E02	H1204F0651	Presser bar lifter lever	1	1	
E03	H6728J8001	Presser bar lifter cam	1	1	
E04	HA309H0681	Thumb screw 1/2(28)	1	1	
E05	HA117H0692	Nut	1	1	
E06	H6733J8001	Spring guide	1	1	
E07	HA500H2010	Presser spring	1	1	
E08	H6705J8001	Presser bar guide bracket	1	1	
E09	H6706J8001	Bracket plate	1	1	
E10	H6707J8001	Upper thread guide	1	1	
E11	HA7311C606	Screw	1	1	SM11/64(40)×15
E12	HA7311CH06	Screw	1	1	SM9/64(40)×8
E13	H6712B8001	Bushing for presser bar	1	1	
E14	H6704J8001	Presser bar	1	1	
E15	HA100H2150	Screw 9/64(40)×11	1	1	SM9/64(40)×11
E16	HA316H0070	Presser foot	1	1	
E17	H6726J8001	Stud screw	1	1	
E18	H6730J8001	Spring	1	1	
E19	H6725J8001	Tension releaser	1	1	
E20	H007013030	E-type stop ring 3	1	1	
E21	H6732J8001	Tension release pin spring	1	1	
E22	H6711J8001	Pullup plate	1	1	
E23	H007013040	E-type stop ring 4	1	1	
E24	H6713J7101	Tension release lever assy	1	1	
E25	H007013060	E-type stop ring 6	2	2	
E26	H6729J8001	Spring	1	1	
E27	H6717J8001	Stud bolt	1	1	
E28	HA300H2080	O-ring	1	1	
E29	H6708J7101	Knee lifter lever (left)	1	1	
E30	HA107H0662	Hinged screw	4	4	SM3/16(28)×7
E31	HG605F8001	Knee lifter rod (long)	1	1	
E32	H5320H8001	Screw	2	2	SM15/64(28)×23.5
E33	H005008060	Spring washer	2	2	
E34	HG607F8001	Bracket	1	1	
E35	HG608F8001	Joint	1	1	
E36	HG609F8001	Knee lifter rod (short)	1	1	
E37	HA100H2050	Screw	1	1	
E38	HA110H0671	Knee lifter lever(right)	1	1	
E39	HA110H0672	Spring for knee lifter lever	1	1	
E40	HA100H2080	Pin for spring	1	1	
E41	HA306H0671	Knee lifter connecting rod	1	1	
E42	H6727J8001	Tension release pin	1	1	

F.OIL LUBRICATION MECHANISM

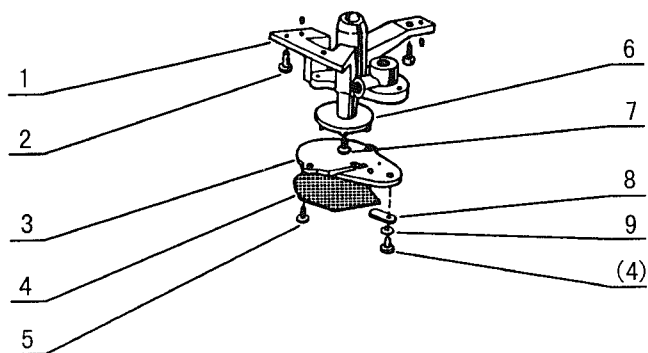
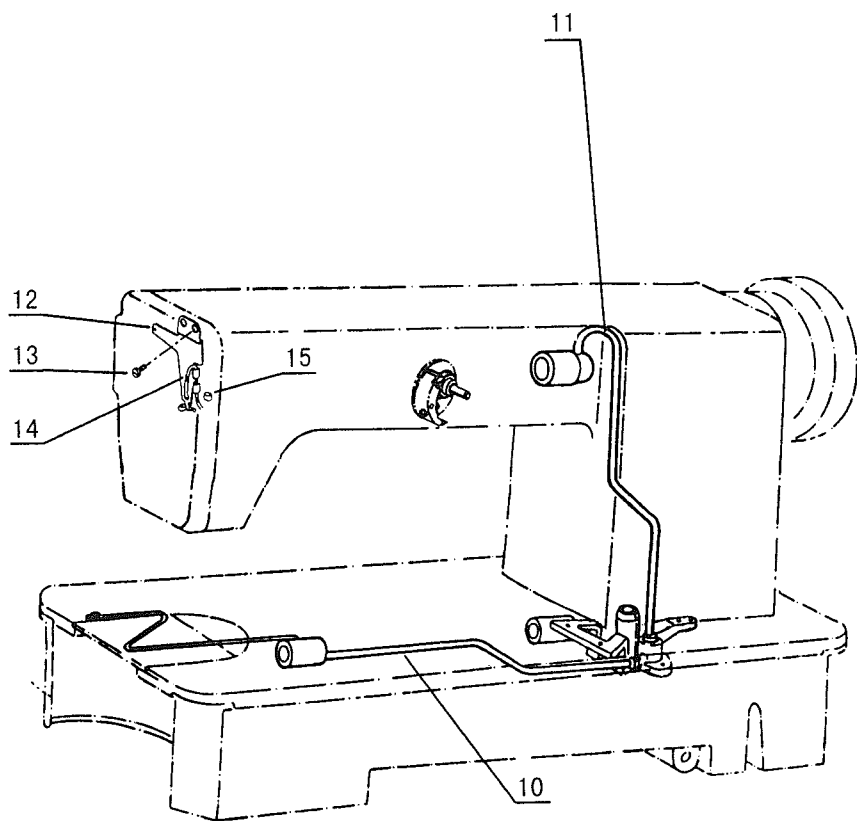

F.OIL LUBRICATION MECHANISM

Fig. No.	Part No.	Description	M D	M	Remarks
F01	HA100I2010	Oil pump body	1	1	
F02	HA100I2090	Screw	3	3	SM11/64(40)×13
F03	HA100I2060	Oil pump fitting plate	1	1	
F04	HA111I0065	Oil pump screen complete	1	1	
F05	HA300I2050	Screw	3	3	SM1/8(44)×13
F06	HA100I2020	Oil pump impeller	1	1	
F07	HA100I2030	Screw	1	1	SM1/8(44)×6.5
F08	HA100I2070	Oil adjusting plate	1	1	
F09	HA100I2050	Spring washer	1	1	
F10	HA707L0065	Oil pipe for hook shaft	1		
F10	HA113I0066	Oil pipe for hook shaft		1	
F11	HA116I0068	Oil pipe for arm shaft	1	1	
F12	H6711P8001	Oil wick holder	1	1	
F13	HA300C2030	Screw 11/64(40)×8	1	1	SM11/64(40)×8
F14	H6729P8002	Oil wick	1	1	
F15	H3200G2030	Holder	1	1	

G.KNIFE MECHANISM

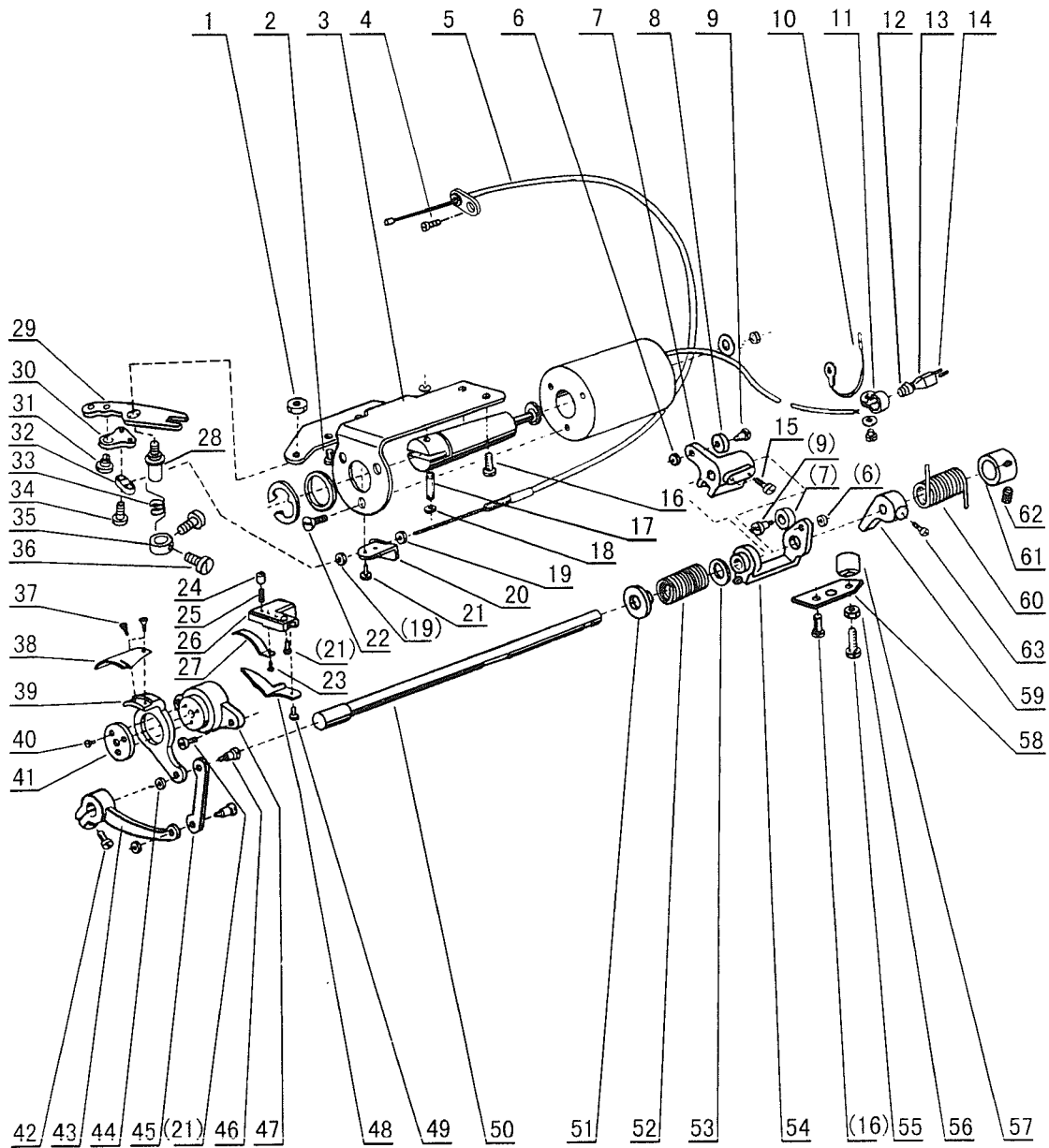

G.KNIFE MECHANISM

Fig. No.	Part No.	Description	M D	M	Remarks
G01	HA710N0683	Nut	1		SM15/64(28)
G02	HA100E2150	Screw	1		SM11/64(40)×10
G03	HA7511N212	Solenoid bracket	1		
G04	HA100C2190	Screw	1		SM11/64(40)×8
G05	HG604H7101	Flexible wire assy.	1		
G06	HA706N0663	Nut	2		SM3/16(28)
G07	HA7211N106	Crank 1	1		
G08	HA7221N106	Crank roller	2		
G09	HA7221N206	Crank screw	2		
G10	HA705Q0065	Ground wire assy.	1		
G11	HA708P0668	Cord holder	1		
G12	HA704O0657	Rubber plug	1		
G13	HA700Q0010	Pin	1		
G14	HA7641B319	Tie-in	2		
G15	HA113F0684	Screw	2		SM15/64(28)×8.5
G16	HA700N0080	Screw	4		SM15/64(28)×12
G17	HA712N0692	Link stud	1		
G18	H007013040	Stop ring	2		
G19	H003002050	Nut	2	M5	
G20	HA712N6913	Holder	1		
G21	HA300C2030	Screw	5		SM11/64(40)×8
G22	HS90011406	Screw	3		
G23	HA7121N304	Screw	1		SM9/64(40)×3.1
G24	HA7121N704	Nut	1		SM9/64(40)
G25	HA7121N604	Screw	1		SM9/64(40)×8.5
G26	HA7121N104	Bracket for fixed blade	1		
G27	HA7121N204	Fixed blade	1		
G28	HA712N0695	Stud screw	1		
G29	HA712N0698	Thread trimmer driving lever	1		
G30	HA712N6910	Flexible wire holder	1		
G31	HA712N0699	Screw	1		SM11/64(40)×5
G32	HA712N6911	Flexible wire presser	1		
G33	HA712N0697	Trimming lever spring	1		
G34	HA712N6912	Screw	2		SM1/8(44)×7
G35	HA712N0696	Collar	1		
G36	HA7311CC06	Screw	2		SM9/64(40)×6
G37	HA7111N704	Screw	2		
G38	HA7111N804	Movable knife(left)	1		
G39	HA704N1112	Knife holding bracket saddle(left)	1		
G40	HA704N1114	Screw	3		SM1/8(44)×5.2
G41	HA704N1113	Washer	1		
G42	HA719B7011	Screw	1		SM11/64(40)×11.4
G43	HA7111N604	Knife driving crank	1		

G.KNIFE MECHANISM

Fig. No.	Part No.	Description	M D	M	Remarks
G44	HA7111N304	Nut	2		SM11/64(40)
G45	HA7111N404	Link	1		
G46	HA7111N204	Screw	2		SM11/64(40)×6.2
G47	HA704N1111	Knife holding bracket saddle	1		
G48	HA7121N404	Thread finger	1		
G49	HA7311CH06	Screw	3		SM9/64(40)×8
G50	HA700N0020	Knife driving shaft	1		
G51	HA700N0050	Bushing	1		
G52	HA700N0040	Coil spring	1		
G53	HA706N0664	Washer	1		
G54	HA7211N206	Crank 2	1		
G55	HA7411N110	Screw	1		SM15/64(28)×23
G56	HA710N0683	Nut	1		SM15/64(28)
G57	HA7411N210	Stopper rubber	1		
G58	HA710N0682	Lever stopper plate	1		
G59	HA709N0671	Stopper lever	1		
G60	HA700N0110	Coil spring	1		
G61	HA715N0711	Collar	1		
G62	HA105D0662	Set screw	1		SM1/4(40)×4
G63	H5320C8001	Screw	1		SM15/64(28)×8

H.WIPER MECHANISM

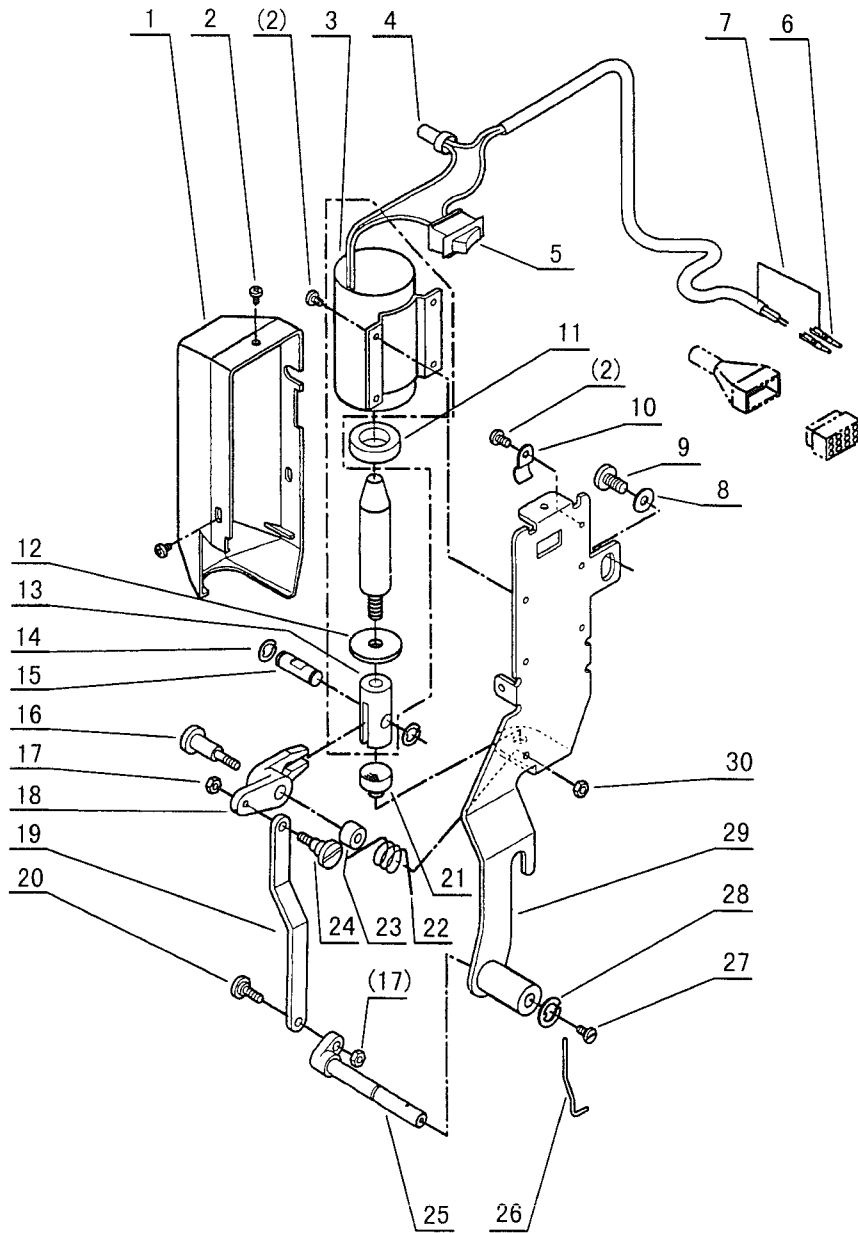

H.WIPER MECHANISM

Fig. No.	Part No.	Description	M D	M	Remarks
H01	H6708M8001	Solenoid cover for wiper mech	1		
H02	HA708P0669	Screw	8		M3×6
H03	H6711M8001	Wiper solenoid	1		
H04	HA708P6610	Connecting 1-SD	1		
H05	HB2254M081	Thread wiper switch	1		
H06	HA7641B319	Terminal pin (male)	2		
H07	HA708P1011	Cord assy	1		
H08	HA700P0010	Washer 6	2		
H09	HA104F0654	Screw	2		SM15/64(28)×10
H10	HA700P0060	Cord holder	1		
H11	H6713M8001	Rubber cushion	1		
H12	H6722M8001	Retain washer	1		
H13	H6712M8001	Joint	1		
H14	H007013040	E-type stop ring 4	2		
H15	H6714M8001	Pin	1		
H16	H6715M8001	Stud screw	1		
H17	HA710P0673	Nut	2		SM9/64(40)
H18	H6716M8001	Wiper driving lever	1		
H19	H6720M8001	Thread wiper connecting rod	1		
H20	HA710P0674	Screw	1		SM9/64(40)×9
H21	H6709M8001	rubber cushion	1		
H22	H6718M8001	Spring	1		
H23	H6717M8001	Spacer	1		
H24	H6719M8001	Stud screw	1		
H25	H6721M8001	Wiper shaft	1		
H26	HA705P0653	Thread wiper	1		
H27	HA104G0654	Screw	1		SM1/8(44)×6
H28	H007013050	E-type stop ring 5	1		
H29	HB2253M081	Thread wiper bracket	1		
H30	HA7111N304	Nut	1		SM11/64(40)

I.TOUCH BACK MECHANISM & DETECTOR MECHANISM

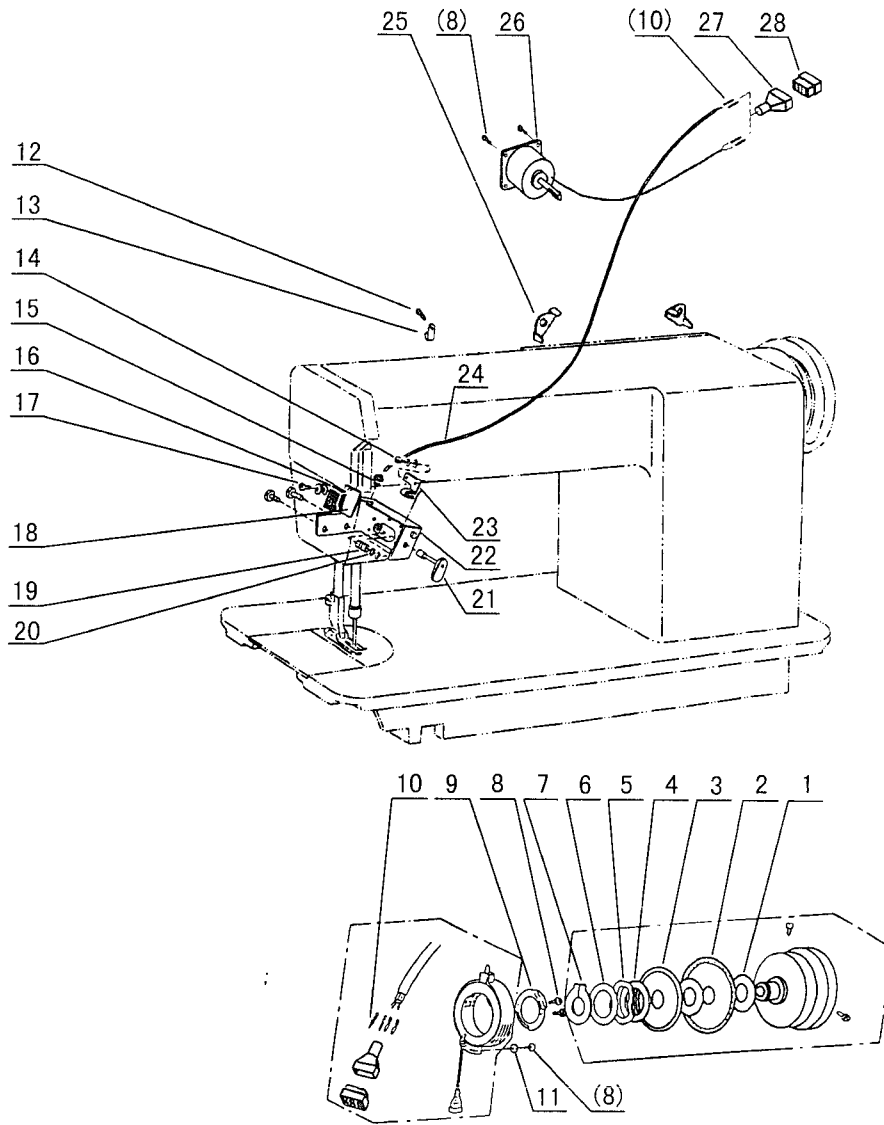

I.TOUCH BACK MECHANISM & DETECTOR MECHANISM

Fig. No.	Part No.	Description	M D	M	Remarks
I01	HA700R0030	Spacer 1	2		
I02	HA700R0010	Speed command disc 1	1		
I03	HA700R0020	Speed command disc 2	1		
I04	HA700R0040	Spacer 2	1		
I05	HA700R0050	Supporter spring	1		
I06	HA700R0060	Washer	1		
I07	H007009300	Stop ring	1		
I08	HA300C2030	Screw	8		SM11/64(40)×8
I09	HA703R0066	Detector bracket supporter	1		
I10	HA7641B319	Terminal pin	4		
I11	HA703R0067	Washer	1		
I12	HA300B2170	Screw	1		SM11/64(40)×8
I13	HA700Q0030	Cord holder	1		
I14	HA704O0659	Screw	2		
I15	HA704O0657	Rubber plug	1		
I16	HA704O0655	Micro switch	1		
I17	HA704O6510	Screw	2		
I18	HA704O0658	Insulator seet	1		
I19	HA704O0653	Coil spring	1		
I20	H007013030	Stop ring	2		
I21	HA704O0021	Push button	1		
I22	HB2252L.081	Bracket for touch switch	1		
I23	HA704O0654	Plate spring	1		
I24	H6704L7101	Cord assy.	1		
I25	H6726N8001	Cord holder	2		
I26	HB2263B072	Solenoid	1		
I27	HA712Q0069	Connector cap	1		
I28	HA700Q0010	Nylon connector 12-pole	1		

J.ACCESSORIES

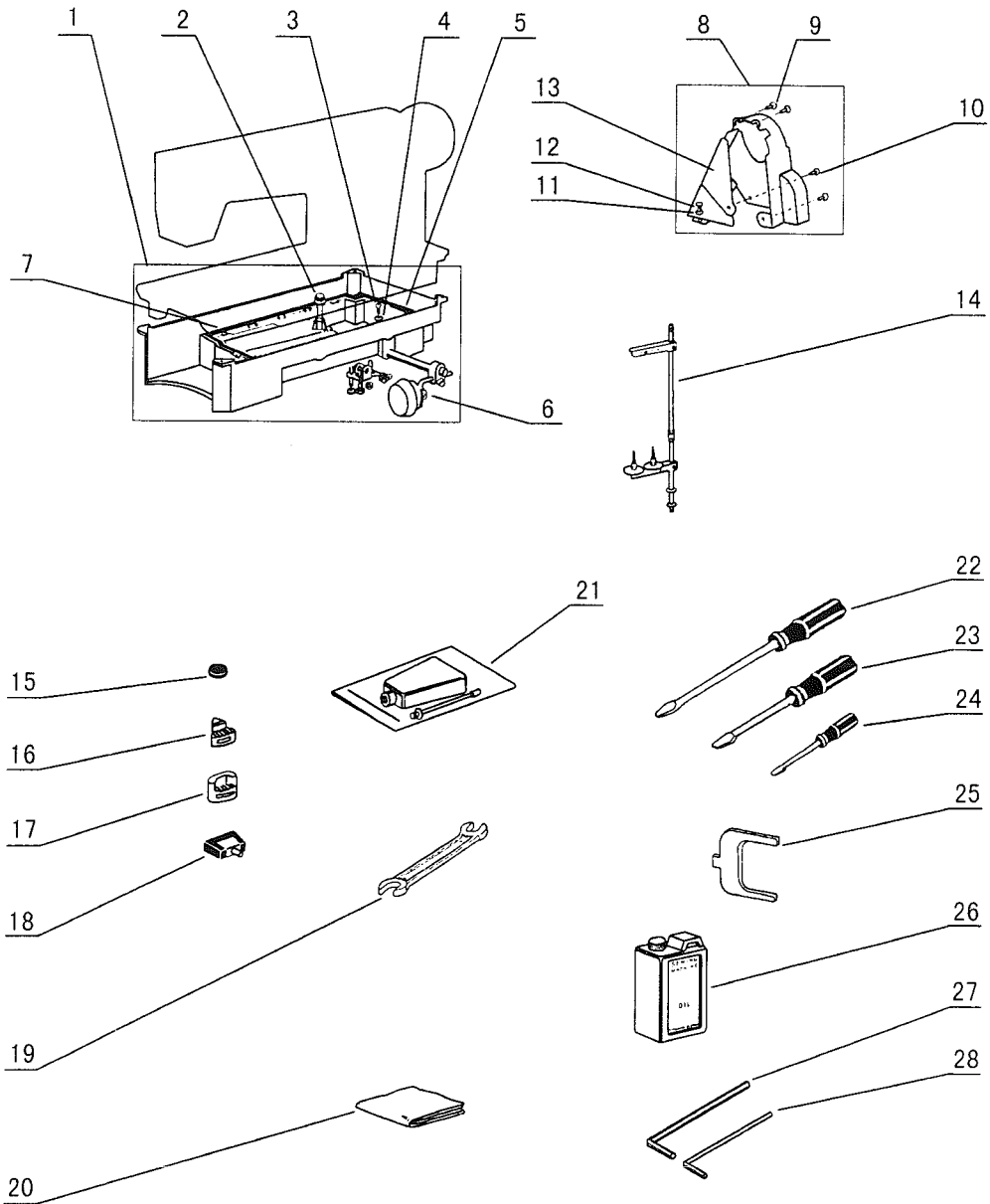

J.ACCESSORIES

Fig. No.	Part No.	Description	M D	M	Remarks
J01	HA304J0065	Oil reservoir	1	1	
J02	HA106J0661	Knee lifter lifting rod	1	1	
J03	HA104J0652	Oil drain screw	1	1	SM5/16(28)×10
J04	HA104J0653	Washer	1	1	
J05	HA104J0654	Gasket for oil reservoir(small)	1	1	
J06	HA106J0066	Knee lifter complete	1	1	
J07	HA104J0655	Gasket for oil reservoir(large)	1	1	
J08	HA305J0066	Belt cover complete	1	1	
J09	HA300B2170	Screw	2	2	SM11/64(40)×8
J10	HA300J2280	Screw	2	2	SM15/64(28)×8
J11	HA300J2230	Washer	2	2	
J12	H801045200	Screw	2	2	
J13	HA305J0663	Belt cover	1	1	
J14	HA200J2030	Thread stand assy.	1	1	
J15	HA100J2120	Magnet block for reservoir	1	1	
J16	HA300J2060	Vibration preventing rubber	2	2	
J17	HA300J2050	Vibration preventing rubber	2	2	
J18	HA307J0067	Table hinge with rubber cushion	1	1	
J19	HA300J2220	Double-ended spanner	1	1	
J20	HA100J2180	Cover	1	1	
J21	HA100J2110	Oil with oiler	1	1	
J22	HA300J2070	Screw driver(large)	1	1	
J23	HA300J2200	Screw driver(middle)	1	1	
J24	HA300J2210	Screw driver(small)	1	1	
J25	HA704S0654	Speed command disc adjusting plate	1		
J26	HA300J2170	Oil box	1	1	
J27	HS68990204	Hexagon socket screw key 3	1	1	
J28	HS68990202	Hexagon socket screw key 2	1		

SHANGHAI HUIGONG NO.3 SEWING MACHINE FACTORY

ADD: 1418, Yishan Road, Shanghai, China

Zip Code: 201103

Overseas Business: TEL: 86-21-64853303 FAX: 86-21-64854304

E-mail: highlead@online.sh.cn <http://www.highlead.com.cn>

The description covered in this manual is subject to change for improvement of the commodity without notice

2005.3. Printed