

Purchasing Dept  
Copy

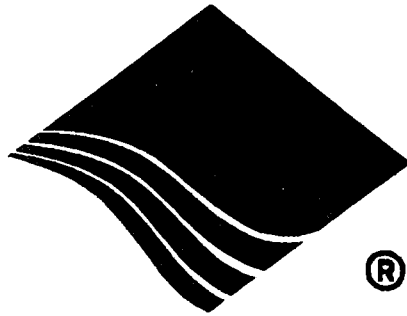

**HIGHLEAD**

**GA1398-1**

**SUPER-HEAVY DUTY TOP AND BOTTOM FEED  
LOCKSTITCH SEWING MACHINE**

**Instruction Manual  
Parts Catalog**

**SHANGHAI HUIGONG NO.3 SEWING MACHINE FACTORY**



----- CONTENTS -----

1. PRECAUTIONS BEFORE STARTING OPERATION.....	1
1) Safety Precautions.....	1
2) Precaution Before Starting Operation.....	1
3) Precaution for Operating Conditions.....	1
2. HOW TO SET HANDWHEEL.....	1
3. LUBRICATION.....	2
4. HEIGHT OF NEEDLE.....	2
5. ADJUSTING SCREW OF NEEDLE HEIGHT.....	3
6. WINDING THE BOBBIN.....	3
7. INSERTING & REMOVING THE BOBBIN.....	4
8. THREADING NEEDLE.....	4
9. THREAD TENSIONS.....	5
10. ADJUSTMENT OF FOOT PRESSURE.....	5
11. ADJUSTMENT OF STITCH LENGTH.....	6
12. SPECIFICATIONS.....	6
13. FACE PLATE, THREAD TAKE-UP LEVER COVER.....	7
14. ARM SHAFT, THREAD TAKE-UP LEVER, NEEDLE BAR.....	9
15. PARTS FOR UPPER FEEDING MECHANISM.....	12
16. PRESSER BAR, UPPER FEED BAR.....	15
17. OSCILLATING SHAFT, SHUTTLE HOOK.....	18
18. THROAT PLATE, LOWER FEED ROCK SHAFT.....	20
19. PARTS FOR THREAD TENSION.....	22
20. ACCESSORIES (1).....	24
21. ACCESSORIES (2).....	26

---

## 1. PRECAUTIONS BEFORE STARTING OPERATION

### 1) Safety Precautions

- (1) When turning the power on, keep your hands and fingers away from the area around/under the needle and the area around the pulley.
- (2) Power must be turned off when the machine is not used.
- (3) The power must be turned off before tilting the machine head, installing or removing the “V” belt, adjusting the machine, or when replacing.
- (4) Avoid placing fingers, hairs, bars etc. nears the pulley, “V” belt, bobbin winder pulley, or motor when the machine is operation. Injury could result.
- (5) Do not insert fingers into the thread take-up cover, under/round the needle, or pulley when the machine is in operation.
- (6) If a belt cover, finger guard are installed, do not operate the machine without these safety devices.

### 2) Precaution Before Starting Operation

- (1) If the machine is lubricated by a drop oiler , never operate the machine before lubricating.
- (2) When a new sewing machine is first turned on, verify the rotational direction of the pulley with the power on.  
(The pulley should rotate counterclockwise when viewed from the pulley.)
- (3) Verify the voltage and phase (single or three) with those given on the machine nameplate.

### 3) Precaution for Operating Conditions

- (1) Avoid using the machine at abnormally high temperatures (35°C or higher) or low temperatures (5°C or lower). Otherwise, machine failure may result.
- (2) Avoid using the machine in dusty conditions.

## 2. HOW TO SET HANDWHEEL

Remove two screws and take off bushing, and set handwheel with the two screws.

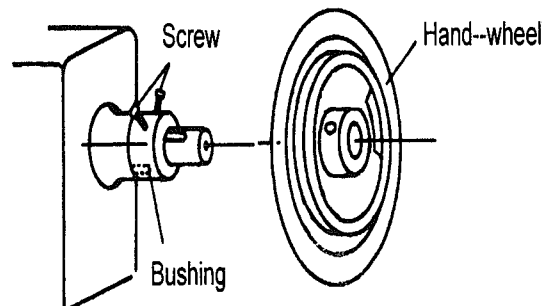

---

### 3. LUBRICATION

Use white spindle oil. When starts the machine initially and after keeps for a long time without using at all, oil sufficiently to respective necessary parts before starting operation, pre-running and with severe use. Oil frequently each necessary parts during operation.

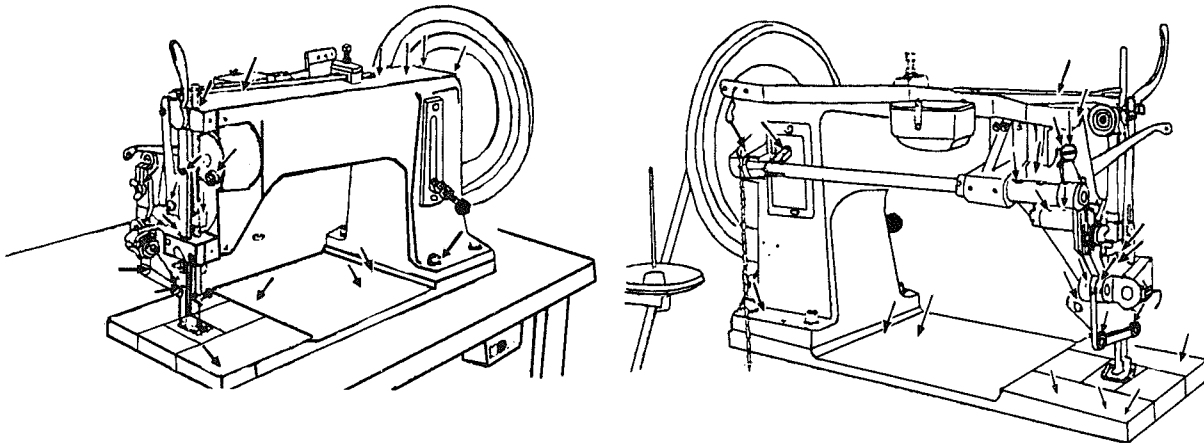

### 4. HEIGHT OF NEEDLE

When the point of hook is at the center of the needle, normal measurement between the hook point and the upper end of the needle eye should be 3~4 mm.

\* Note: the measurement, is for standard needle size. To adjust the measurement, raise or lower the needle bar as may be required.

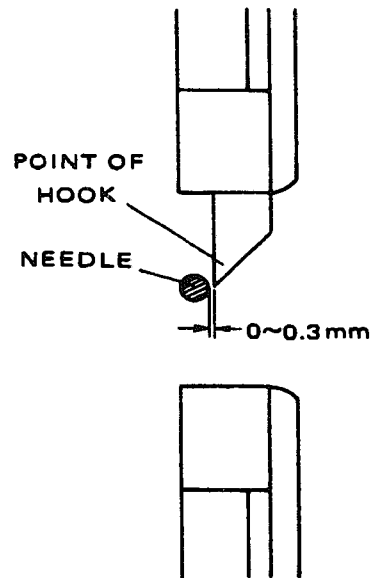
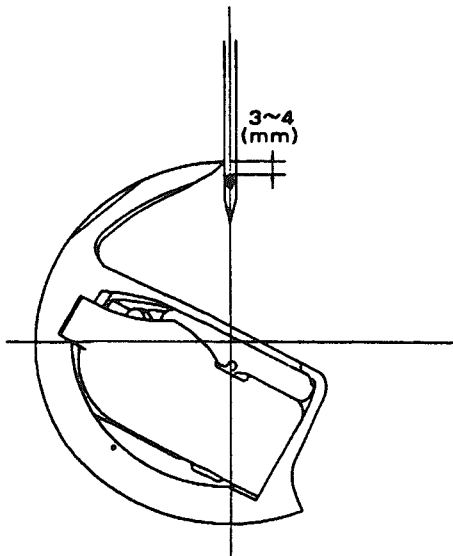

---

## 5. ADJUSTING SCREW OF NEEDLE HEIGHT

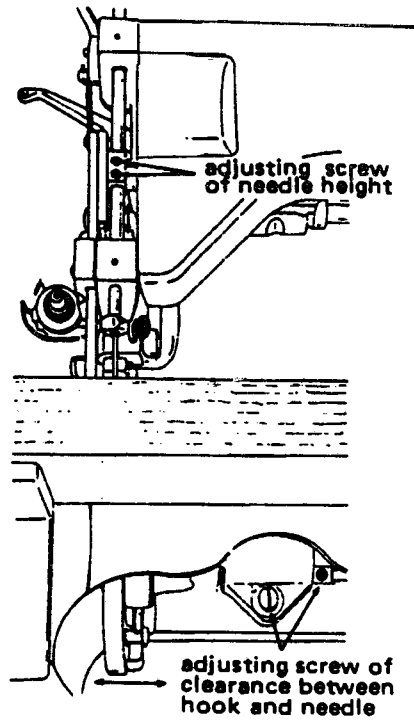

## 6. WINDING THE BOBBIN

- \* Set bobbin winder as Shown
- B: Adjustment of center position
- C: Adjustment of winding amount

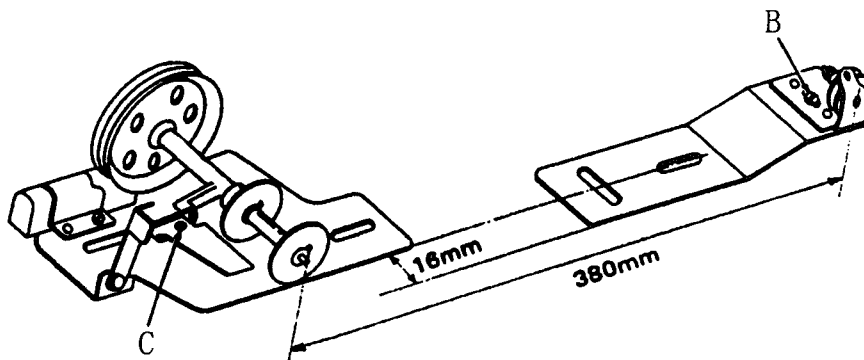

---

## 7. INSERTING & REMOVING THE BOBBIN

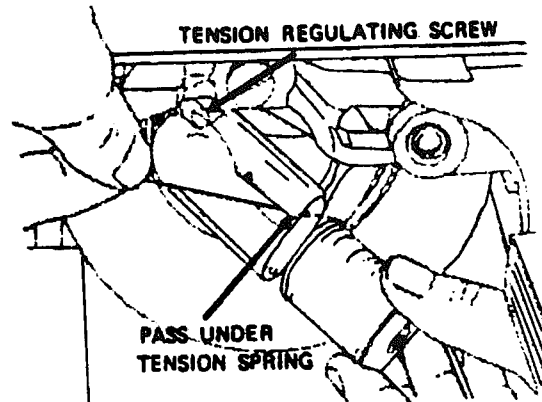
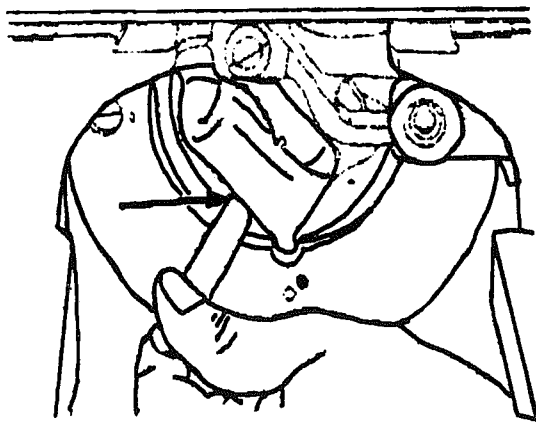

## 8. THREADING NEEDLE

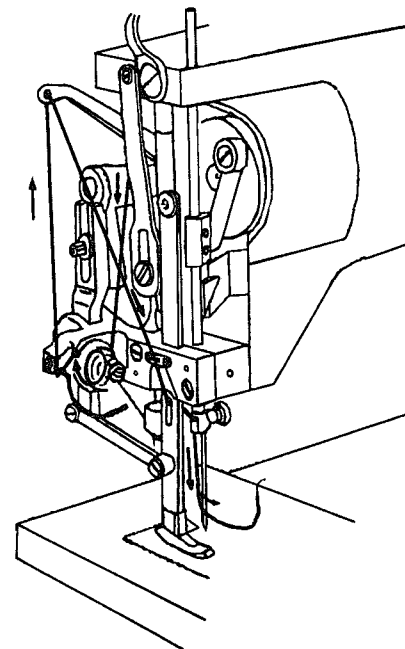
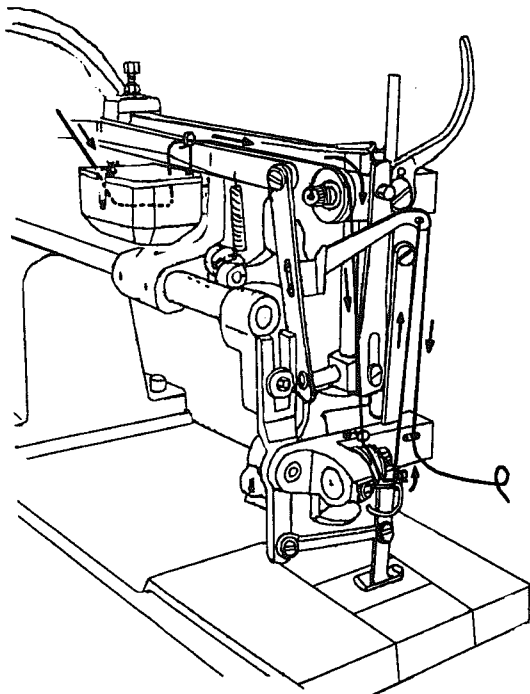

---

## 9. THREAD TENSIONS

more tension...turn to right

less tension...turn to left

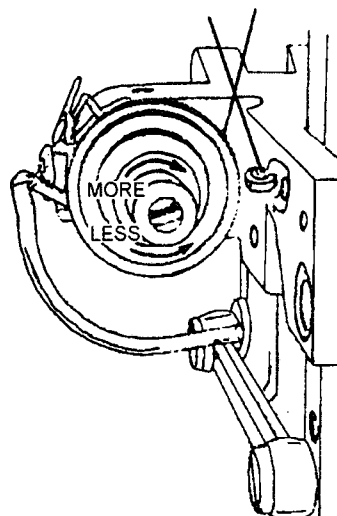
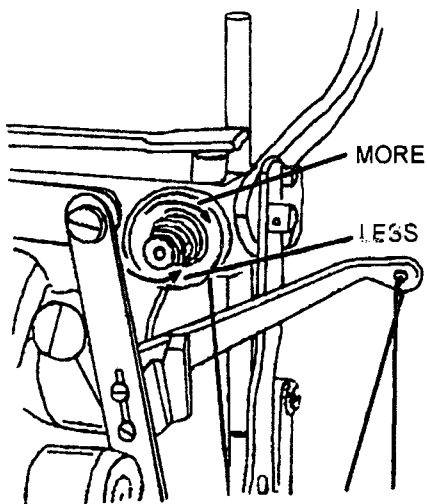

## 10. ADJUSTMENT OF FOOT PRESSURE

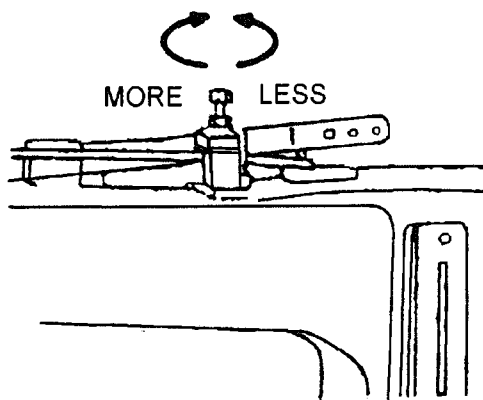



## 11. ADJUSTMENT OF STITCH LENGTH

Adjust stitch length by serrated nut (A) and tighten nut (B) against nut (A)

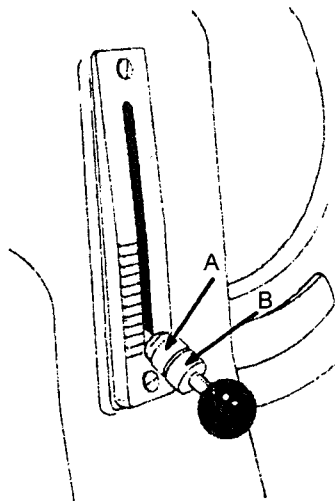

## 12. SPECIFICATIONS

Material weight	Super-thick material	
Max. speed	700 rpm	
Stitch length	0 - 15mm	
Needle bar stroke	56.7mm	
Presser foot	Hand Lifter	29 mm
	Knee lifter	32 mm
Needle type	Schmetz 1000 (#250)	
Shuttle hook	KSP7-31	
Bobbin	φ 7.7 × 38	
Oil lubrication method	Manual	
Bed dimensions	654 × 258 mm	

A. FACE PLATE, THREAD TAKE-UP LEVER COVER

---

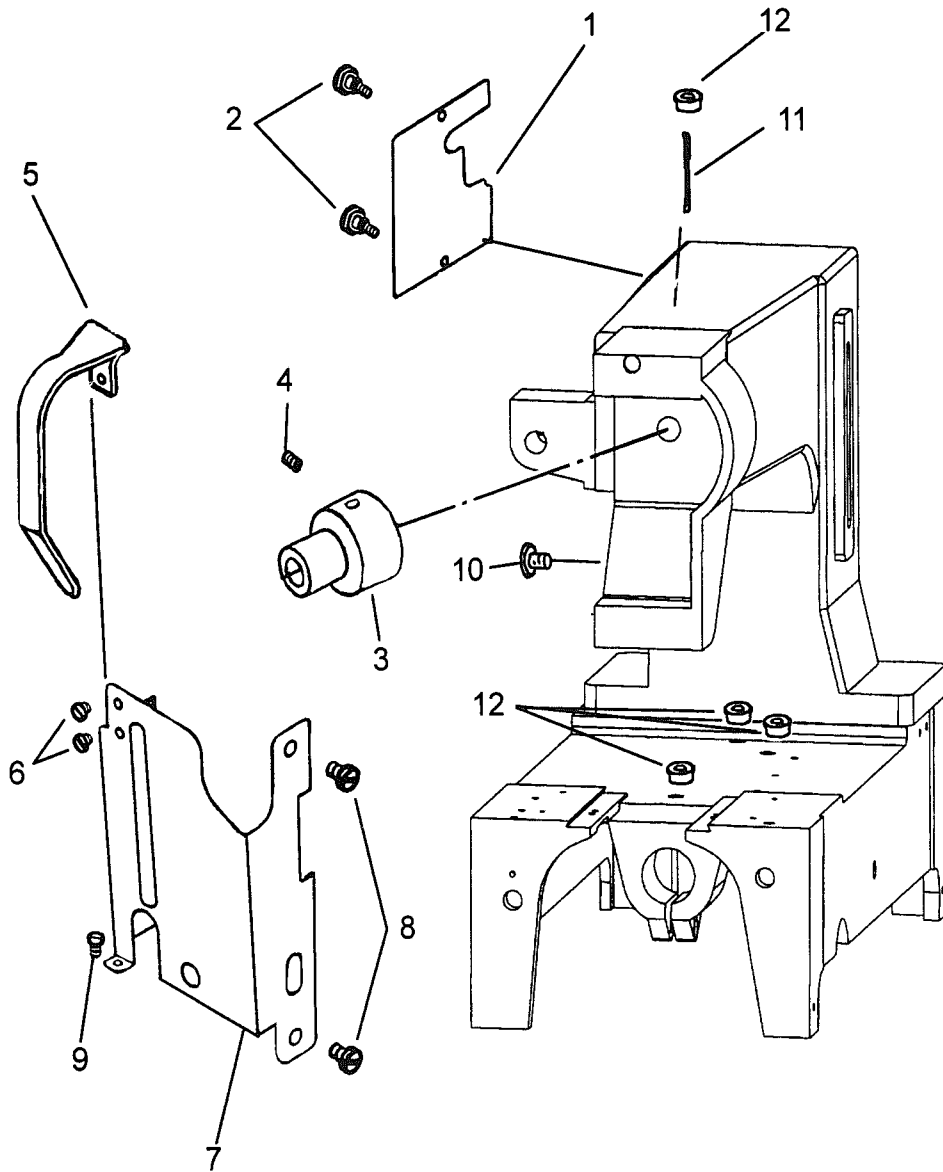

# A. FACE PLATE、THREAD TAKE-UP LEVER COVER

Fig. No.	Part No.	Description	Pcs.	Remarks
A01	HH510B8001	Arm side cover	1	
A02	HH511B8001	Screw	2	SM9/64 (40)
A03	HH526B8001	Arm shaft bushing	1	
A04	H6718Q8001	Screw	1	SM15/64 (28) × 18
A05	HH514B8001	Thread take-up lever cover	1	
A06	H409040040	Screw	2	M4 × 4
A07	HH517B8001	Face plate	1	
A08	HH514H8001	Screw	2	SM17/64 (24) × 15
A09	HE013B8001	Screw	1	SM9/64 (40) × 8
A10	H7330C8001	Screw	1	M4 × 0.7 L=4
A11	H2000M0080	Oil tube	4	
A12	H2000M0090	Oil cup	4	

B. ARM SHAFT, THREAD TAKE-UP LEVER, NEEDLE BAR

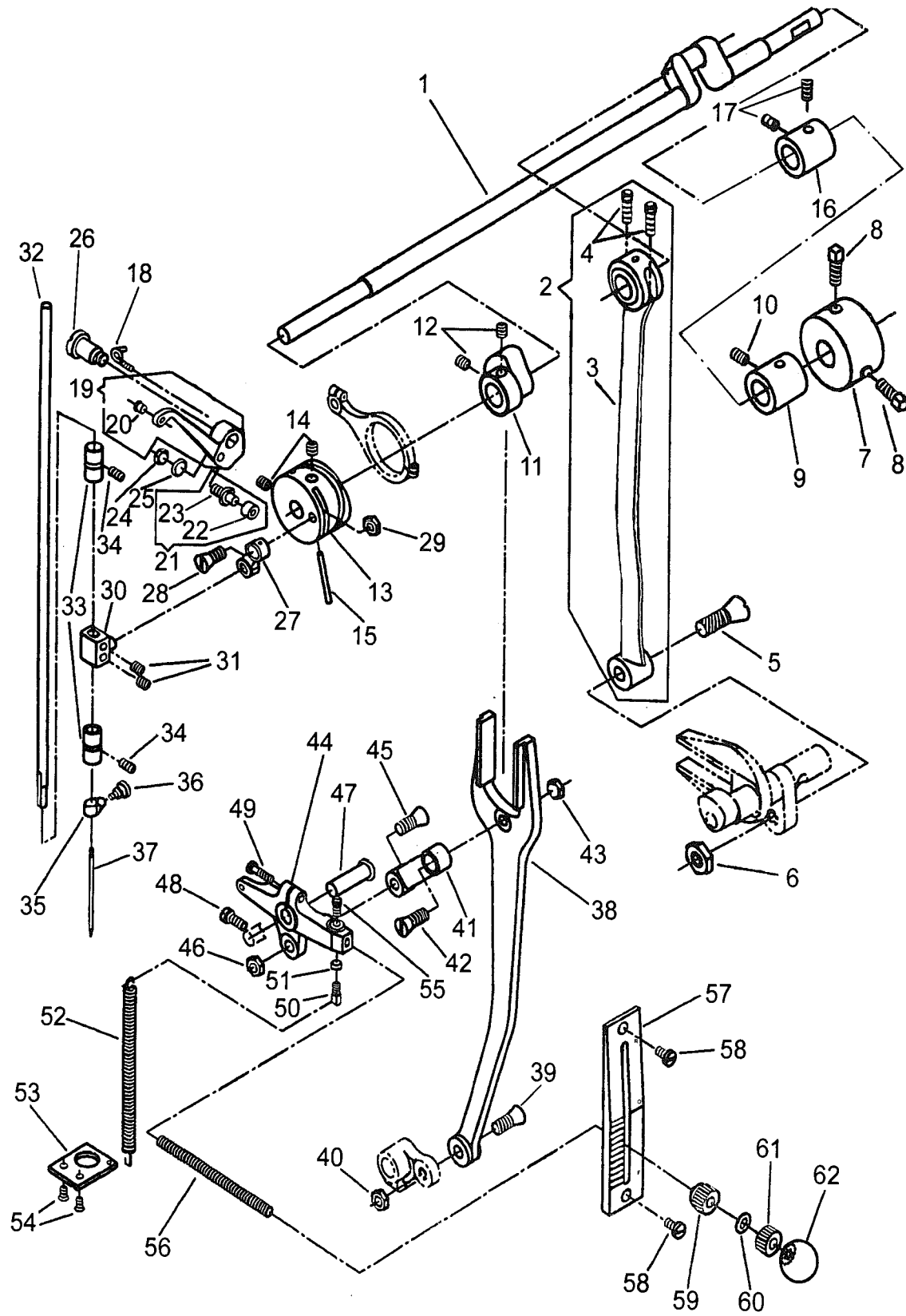

## B. ARM SHAFT、THREAD TAKE-UP LEVER、NEEDLE BAR

Fig. No.	Part No.	Description	Pcs.	Remarks
B01	HH505C8001	Arm shaft	1	
B02	HH506C7101	Rock shaft connecting rod complete	1	
B03	HH507C8001	Rock shaft connecting rod	1	
B04	H5320H8001	Screw	2	SM15/64 (28) × 23
B05	HH509C8001	Screw	1	SM1/2 (20)
B06	HH510C8001	Nut	1	SM1/2 (20)
B07	HH511C8001	Arm shaft collar	1	
B08	HH512C8001	Screw	2	SM5/16 (18)
B09	HH515C8001	Arm shaft bushing	1	
B10	H4708D8001	Screw	1	SM1/4 (24) × 13
B11	HH517C8001	Feed driving eccentric	1	
B12	HH518C8001	Screw	2	SM5/16 (24)
B13	HH520C8001	Thread take-up cam	1	
B14	HH518C8001	Screw	2	SM5/16 (24)
B15	H602050600	Taper pin	1	
B16	HH579C7901	Thrust collar	1	
B17	HA305E0662	Screw	2	SM15/64 (28)
B18	HH522C7101	Thread guide (upper)	1	
B19	HH525C7101	Thread take-up lever complete	1	
B20	HH527C8001	Thread take-up lever eyelet	1	
B21	HH528C7101	Take-up lever roller complete	1	
B22	H7213C8001	Thread take-up lever roller	1	
B23	HH530C8001	Screw	1	SM9/32 (28)
B24	HE034E8001	Nut	1	SM9/32 (28)
B25	H005081022	Washer	1	
B26	HH533C8001	Screw	1	SM3/8 (16)
B27	HH534C8001	Needle bar connecting link	1	
B28	HH535C8001	Screw	1	SM3/8 (28)
B29	HH536C8001	Nut	1	SM3/8 (28)
B30	HH538C8001	Needle bar connecting stud	1	
B31	HH518C8001	Screw	2	SM5/16 (24) × 8
B32	HH540C8001	Needle bar	1	
B33	HH541C8001	Needle bar bushing	2	
B34	HE006D8001	Screw	2	SM17/64 (24) × 11
B35	HH544C8001	Needle clamp	1	
B36	HE919C8001	Screw	1	SM3/16 (32)
B37	HH546C8001	Needle	1	SM × 1000 (250/27)
B38	HH548C8001	Feed forked connection	1	
B39	HH549C8001	Screw	1	SM3/8 (28)
B40	HH536C8001	Nut	1	SM3/8 (28)
B41	HH552C8001	Feed connecting link	1	
B42	HH549C8001	Screw	1	SM3/8 (28)
B43	HH536C8001	Nut	1	SM3/8 (28)

## B. ARM SHAFT, THREAD TAKE-UP LEVER, NEEDLE BAR

Fig No	Part No.	Description	Pcs.	Remarks
B44	HH556C8001	Feed regulator	1	
B45	HH549C8001	Screw	1	SM3/8(28)
B46	HH536C8001	Nut	1	SM3/8(28)
B47	HH559C8001	Hinge stud	1	
B48	HE040D8001	Screw	1	SM17/64(24) × 17.5
B49	H401050200	Screw	1	M5 × 0.8 L=21
B50	HH562C8001	Screw	1	M5 × 0.8 L=10
B51	H003001050	Nut	1	M5 × 0.8
B52	HH564C8001	Spring	1	
B53	HH565C8001	Hook plate	1	
B54	H5715B8001	Screw	2	SM11/64(24)
B55	H7312G8001	Screw	1	M5 × 0.8 L=12
B56	HH569C8001	Feed regulating lever	1	
B57	HH570C8001	Stitch length plate	1	
B58	H7360C8001	Screw	2	M6 × 1 L=12
B59	HH572C8001	Knurling tool (A)	1	
B60	H005108016	Washer	1	
B61	HH574C8001	Knurling tool (B)	1	
B62	HF01008250	Knob	1	M8 × SR25 L=16

# C. PARTS FOR UPPER FEEDING MECHANISM

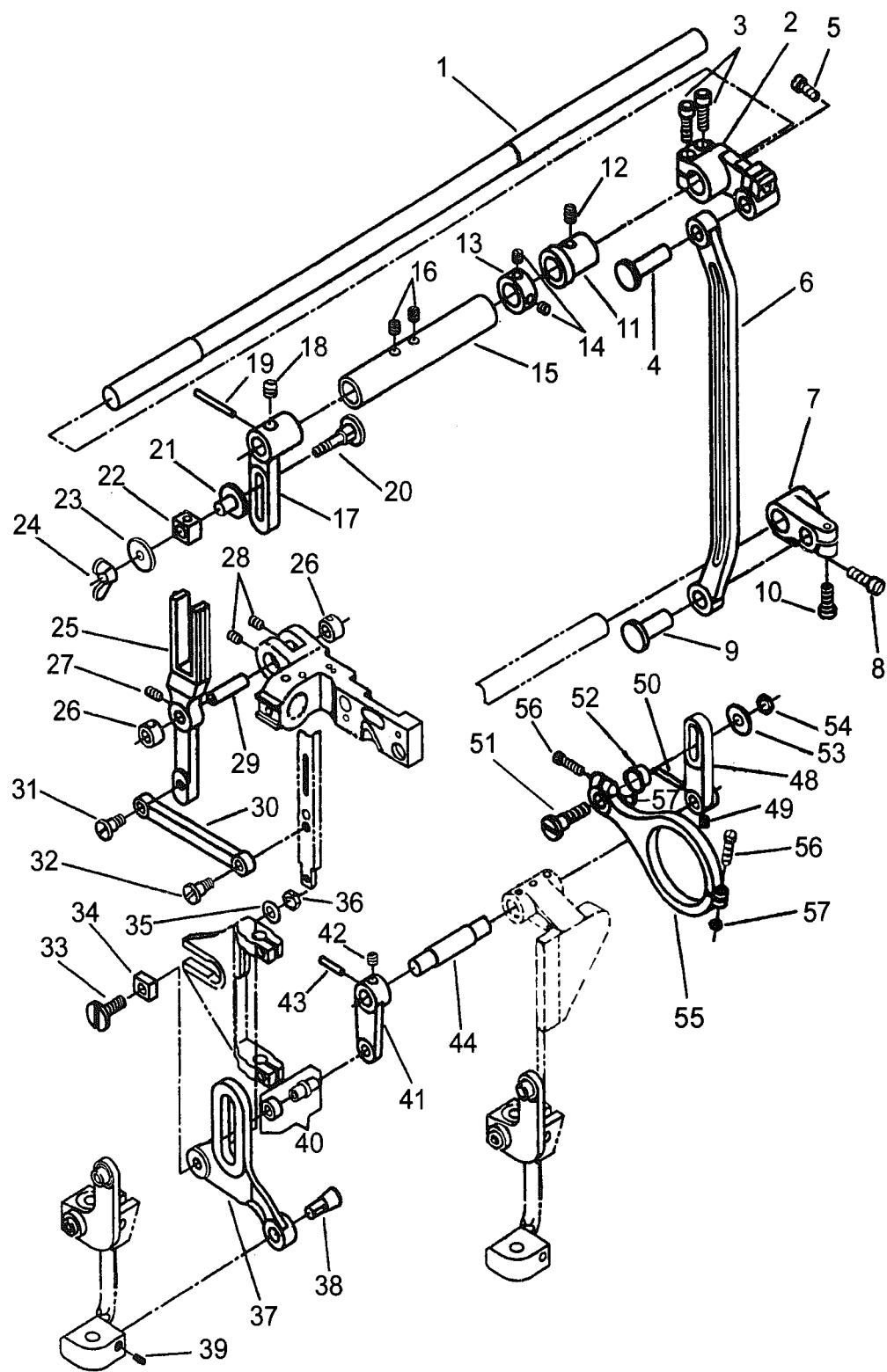

### C. PARTS FOR UPPER FEEDING MECHANISM

Fig. No.	Part No.	Description	Pcs.	Remarks
C01	HH505D8001	Upper feed shaft	1	
C02	HH507D8001	Upper feed shaft crank	1	
C03	HS90321120	Screw	2	
C04	HH509D8001	Hing stud (upper)	1	
C05	HE126E8001	Screw	1	SM7/32 (32)
C06	HH512D8001	Connecting rod	1	
C07	HH514D8001	Shaft crank (lower)	1	
C08	HS90321120	Screw	1	
C09	HH516D8001	Hing stud (lower)	1	
C10	HE040D8001	Screw	1	SM17/64 (24) × 17.5
C11	HH518D8001	Upper feed shaft bushing (back)	1	
C12	HE007E8001	Screw	1	SM17/64 (24)
C13	HH521D8001	Upper feed shaft collar	1	
C14	HE023C8001	Screw	2	SM1/4 (32)
C15	HH523D8001	Upper feed shaft bushing (front)	1	
C16	HE013C8001	Screw	2	SM17/64 (24)
C17	HH525D8001	Upper feed shaft adjusting arm	1	
C18	HH518C8001	Screw	1	SM5/16 (24) × 8
C19	H602040350	Taper pin	1	
C20	HH528D8001	Screw	1	
C21	HH529D8001	Pipe	1	
C22	HH530D8001	Slide block	1	
C23	H7329C8001	Washer	1	
C24	H3119F8001	Wing nut	1	SM7/32 (32)
C25	HH533D8001	Upper feed forked connection	1	
C26	HH534D8001	Upper feed forked connection shaft bushing	2	
C27	HE053C8001	Screw	1	
C28	HE028E8001	Screw	2	
C29	HH537D8001	Upper feed forked connection shaft	1	
C30	HH539D8001	Connecting crank	1	
C31	HH540D8001	Screw (large)	1	
C32	HH541D8001	Screw (small)	1	
C33	HH542D8001	Screw	1	
C34	HH543D8001	Slide block	1	
C35	H3204D6512	Washer	1	
C36	HE034E8001	Nut	1	
C37	HH546D8001	Upper feed bar bell	1	
C38	HH547D8001	Stud pin	1	
C39	HA307C0662	Screw	1	SM1/4 (40) × 5
C40	HH551D7101	Roller stud	1	
C41	HH556D8001	Rock shaft crank	1	
C42	HA305E0662	Screw	1	SM15/64 (28) × 4.5
C43	H602040220	Taper pin	1	



### C. PARTS FOR UPPER FEEDING MECHANISM

Fig. No.	Part No.	Description	Pcs.	Remarks
C44	HH559D8001	Adjusting arm shaft	1	SM15/64 (28) × 4.5
C48	HH563D8001	Adjusting arm	1	
C49	HA305E0662	Screw	1	
C50	H602040240	Taper pin	1	
C51	HH566D8001	Screw	1	
C52	HH567D8001	Pipe	1	
C53	HH568D8001	Washer	1	
C54	HE034E8001	Nut	1	
C55	HH570D8001	Eccentric rod	1	
C56	HH571D8001	Screw	2	
C57	HH572D8001	Nut	2	

# D. PRESSER BAR, UPPER FEED BAR

C. PARTS FOR UPPER FEEDING MECHANISM

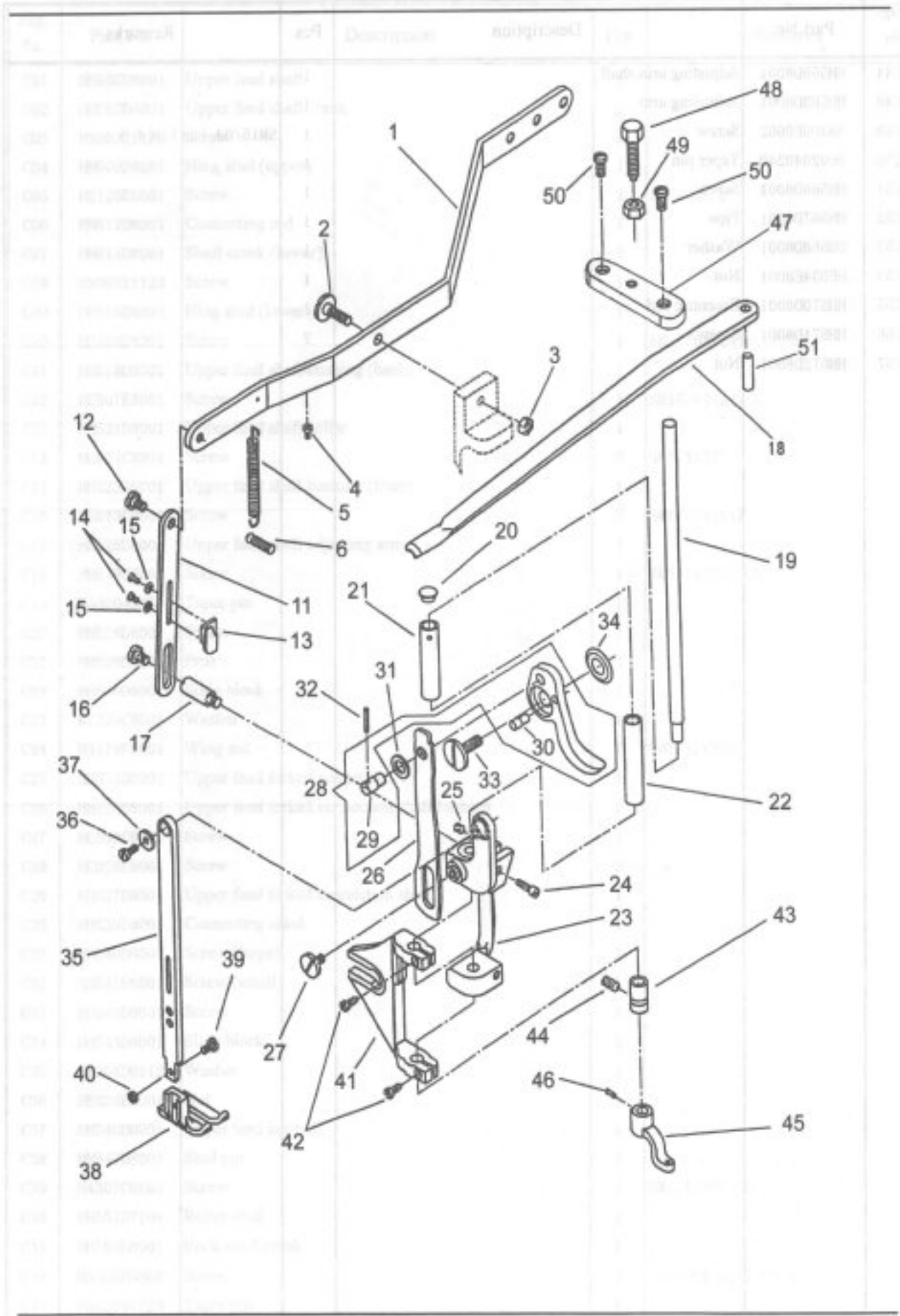

# D. PRESSER BAR, UPPER FEED BAR

Fig. No.	Part No.	Description	Pcs.	Remarks
D01	HH504E8001	Foot lifting lever	1	
D02	HH505E8001	Screw	1	SM17/64 (24)
D03	HE131E8001	Nut	1	SM17/64 (24)
D04	HE006L8001	Screw	1	SM9/64 (40) × 6.5
D05	HH508E8001	Foot lifting lever spring	1	
D06	HE007F8001	Screw	1	SM17/64 (24) × 19
D11	HH515E8001	Lifting bracket	1	
D12	HE005F8001	Screw	1	SM17/64 (24)
D13	HH517E8001	Tension release lever	1	
D14	H3100F2360	Screw	2	SM9/64 (40) × 6.5
D15	H6644C8001	Washer	2	
D16	HE005F8001	Screw	1	SM17/64 (24)
D17	HH521E8001	Screw	1	SM17/64 (24) × 8
D18	HH522E8001	Presser bar spring	1	
D19	HH523E8001	Presser bar	1	
D20	HH524E8001	Sleeve cap	1	
D21	HH525E8001	Presser bar sleeve (upper)	1	
D22	HH526E8001	Presser bar sleeve (lower)	1	
D23	HH529E8001	Presser bar clamp	1	
D24	HA304G0656	Screw	1	SM3/16 (28) × 6.5
D25	HA3411D308	Screw	1	SM15/64 (28) × 6
D26	HH531E8001	Presser bar lifting link	1	
D27	HH533E8001	Screw	1	SM1/4 (24) × 11
D28	HH904E7101	Presser bar lifting lever complete	1	
D29	HH538E8001	Pin (large)	1	
D30	HH539E8001	Pin (small)	1	
D31	H005410016	Washer	1	
D32	H609030180	Pin	1	
D33	HH540E8001	Screw	1	SM5/16 (24)
D34	HH541E8001	Washer	1	
D35	HH543E8001	Upper feed bar	1	
D36	HH544E8001	Screw	1	SM3/16 (32) × 11
D37	H721218001	Washer	1	
D38	HH546E8001	Upper feed foot	1	
D39	HH548E8001	Screw	1	SM3/16 (40) × 9
D40	HH549E8001	Nut	1	SM3/16 (40)
D41	HH551E8001	Presser bar lifting bracket	1	
D42	HA304G0656	Screw	2	SM3/16 (28)
D43	HH541C8001	Presser bar bushing (lower)	1	
D44	HE006D8001	Screw	1	SM17/64 (24) × 11
D45	HH556E8001	Inner presser foot	1	
D46	HA307C0662	Screw	1	SM1/4 (40) × 5
D47	HH559E8001	Presser bar spring bracket	1	

# D. PRESSER BAR, UPPER FEED BAR

Fig. No.	Part No.	Description	Pcs.	Remarks
D48	HH560E8001	Screw	1	SM5/16 (18) × 32
D49	HH561E8001	Nut	1	SM5/16 (18)
D50	H320710661	Screw	2	SM15/64 (28) × 22
D51	H604060200	Pin	1	

E. OSCILLATING SHAFT, SHUTTLE HOOK

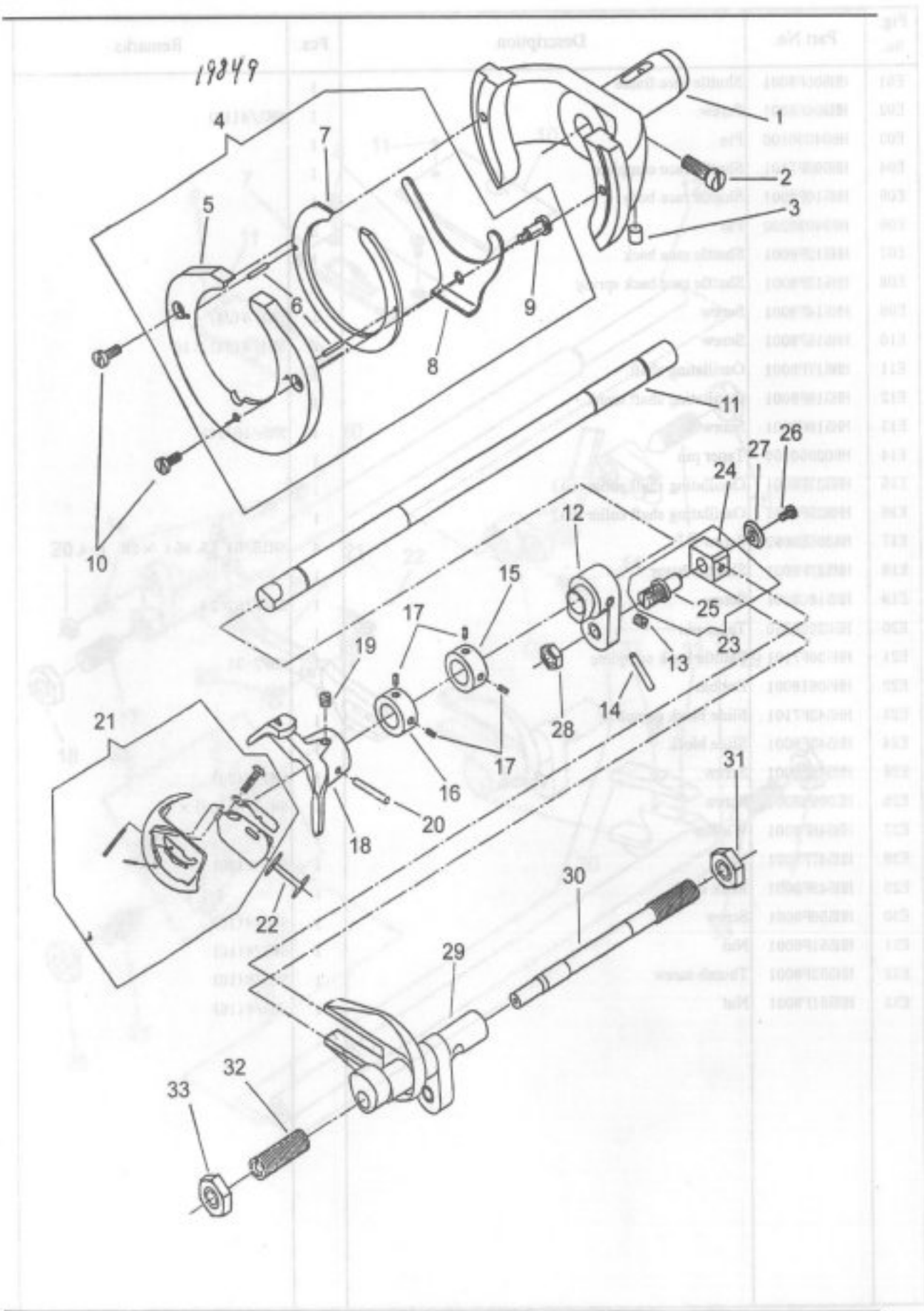

# E. OSCILLATING SHAFT, SHUTTLE HOOK

Fig No.	Part No.	Description	Pcs.	Remarks
E01	HH505F8001	Shuttle race frame	1	
E02	HH506F8001	Screw	1	SM3/8 (18)
E03	H604050100	Pin	1	
E04	HH509F7101	Shuttle race complete	1	
E05	HH510F8001	Shuttle race body	1	
E06	H604030200	Pin	2	
E07	HH512F8001	Shuttle race back	1	
E08	HH513F8001	Shuttle race back spring	1	
E09	HH514F8001	Screw	1	SM1/4 (24)
E10	HH515F8001	Screw	2	SM1/4 (24) × 16
E11	HH517F8001	Oscillating shaft	1	
E12	HH519F8001	Oscillating shaft crank	1	
E13	HH518C8001	Screw	1	SM5/16 (24)
E14	H602050350	Taper pin	1	
E15	HH523F8001	Oscillating shaft collar (A)	1	
E16	HH525F8001	Oscillating shaft collar (B)	1	
E17	HA305E0662	Screw	4	SM15/64 (5.95) × 28 L=4.5
E18	HH527F8001	Shuttle driver	1	
E19	HH518C8001	Screw	1	SM5/16 × 24
E20	H602050350	Taper pin	1	
E21	HH530F7101	Shuttle hook complete	1	KSP7-31
E22	HH50618001	Bobbin	1	
E23	HH542F7101	Slide block complete	1	
E24	HH543F8001	Slide block	1	
E25	HH544F8001	Screw	1	SM1/2 (20)
E26	HE009N8001	Screw	1	SM13/64 (32) × 9
E27	HH546F8001	Washer	1	
E28	HH547F8001	Nut	1	SM1/2 (20)
E29	HH549F8001	Rock shaft	1	
E30	HH550F8001	Screw	1	SM5/8 (16)
E31	HH551F8001	Nut	1	SM5/8 (16)
E32	HH552F8001	Thumb screw	1	SM5/8 (16)
E33	HH551F8001	Nut	1	SM5/8 (16)

F. THROAT PLATE, LOWER FEED ROCK SHAFT

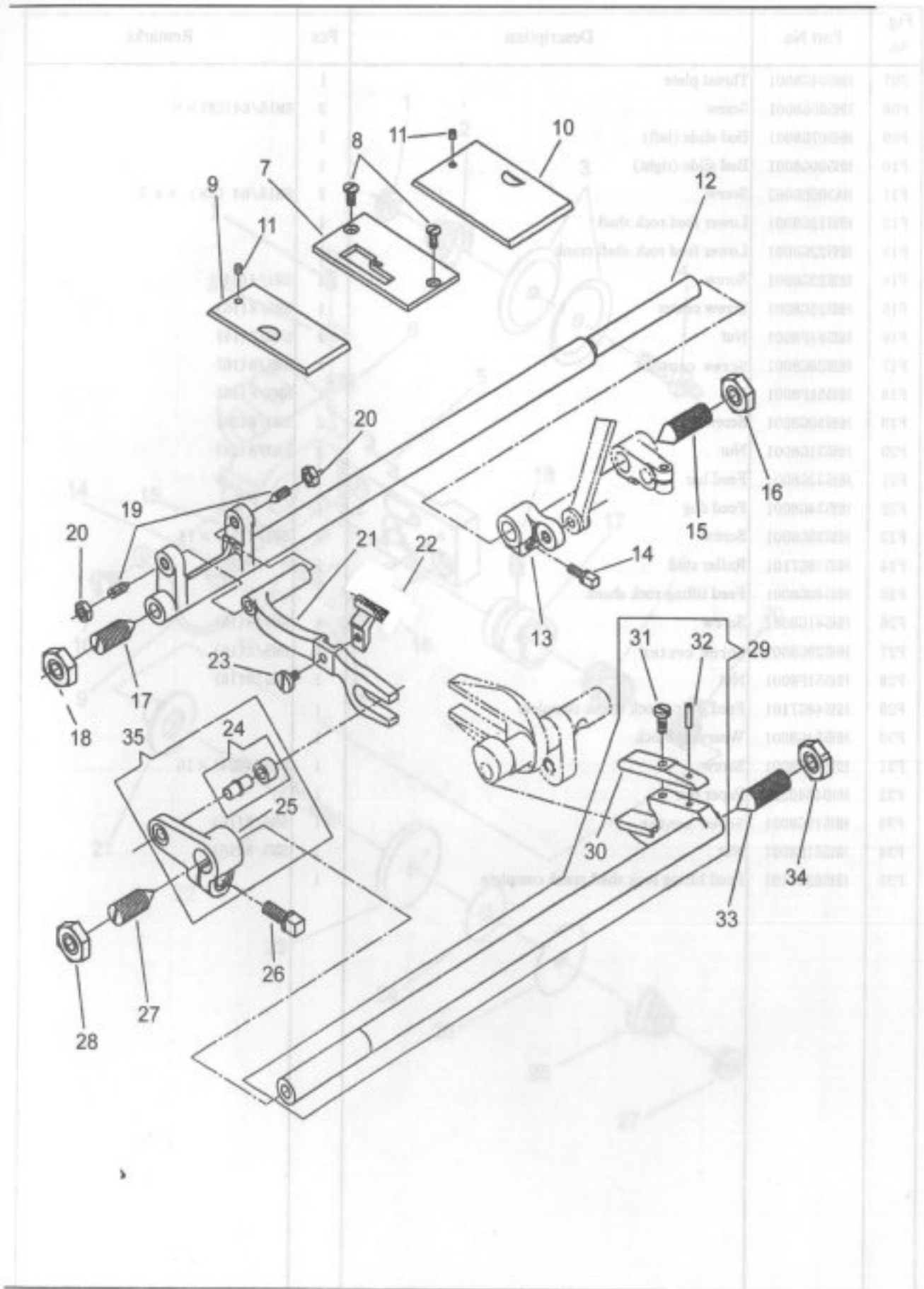

## F. THROAT PLATE, LOWER FEED ROCK SHAFT

Fig. No.	Part No.	Description	Pcs.	Remarks
F07	HH504G8001	Throat plate	1	
F08	HH505G8001	Screw	2	SM15/64 (28) × 9
F09	HH507G8001	Bed slide (left)	1	
F10	HH509G8001	Bed slide (right)	1	
F11	HA305E0662	Screw	2	SM15/64 (28) × 4.5
F12	HH512G8001	Lower feed rock shaft	1	
F13	HH522G8001	Lower feed rock shaft crank	1	
F14	HH523G8001	Screw	1	SM1/4 (24)
F15	HH525G8001	Screw center	1	SM5/8 (16)
F16	HH551F8001	Nut	1	SM5/8 (16)
F17	HH528G8001	Screw center	1	SM5/8 (16)
F18	HH551F8001	Nut	1	SM5/8 (16)
F19	HH530G8001	Screw	2	SM3/8 (28)
F20	HH531G8001	Nut	2	SM3/8 (28)
F21	HH533G8001	Feed bar	1	
F22	HH534G8001	Feed dog	1	
F23	HH535G8001	Screw	1	SM1/4 (24) × 11
F24	HH536G7101	Roller stud	1	
F25	HH540G8001	Feed lifting rock shank	1	
F26	HH541G8001	Screw	1	SM3/8 (18)
F27	HH528G8001	Screw center	1	SM5/8 (16)
F28	HH551F8001	Nut	1	SM5/8 (16)
F29	HH548G7101	Feed lifting rock shank complete	1	
F30	HH554G8001	Wearing block	1	
F31	HH515F8001	Screw	1	SM1/4 (24) × 16
F32	H604040220	Paper pin	1	
F33	HH525G8001	Screw center	1	SM5/8 (16)
F34	HH551F8001	Nut	1	SM5/8 (16)
F35	HH562G7101	Feed lifting rock shaft crank complete	1	



# G. PARTS FOR THREAD TENSION

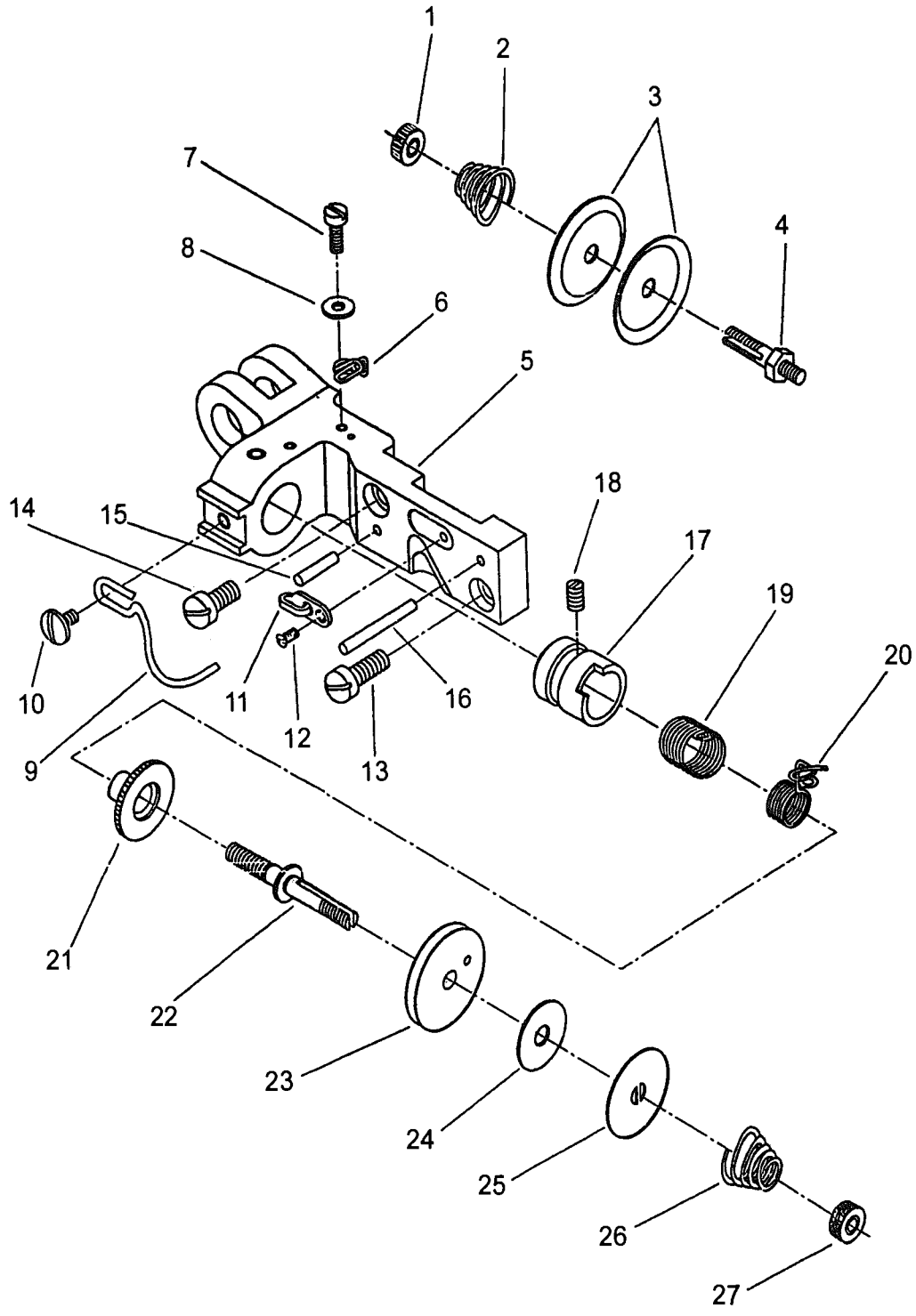

## G. PARTS FOR THREAD TENSION

Fig. No.	Part No.	Description	Pcs.	Remarks
G01	HH532H8001	Tension thumb nut	1	SM1/4 (40)
G02	HH505H8001	Tension spring	1	
G03	HH506H8001	Tension disc	2	
G04	HH507H8001	Tension stud (post)	1	
G05	HH509H8001	Connecting bracket	1	
G06	HH510H8001	Thread guide (middle)	1	
G07	HA111G0683	Screw	1	
G08	H005001040	Washer	1	
G09	HH513H8001	Large thread guide	1	SM3/16 (40) × 8
G10	HH511H8001	Screw	1	
G11	HA106B0675	Thread guide (lower)	1	SM9/64 (40)
G12	HA106B0676	Screw	1	
G13	HE040D8001	Screw	1	SM17/64 (24) × 17.5
G14	HH514H8001	Screw	1	
G15	H604040220	Pin	1	SM17/64 (24) × 15
G16	H604040350	Pin	1	
G17	HH522H8001	Tension regulator	1	SM7/32 (32) × 7
G18	HE028E8001	Screw	1	
G19	HH524H8001	Regulating spring	1	
G20	HH525H8001	Thread take-up spring	1	
G21	HH526H8001	Thread take-up spring adjusting sleeve		
G22	HH527H8001	Thread controller stud	1	
G23	HH528H8001	Tension disc	1	
G24	HH529H8001	Tension disc leather	1	SM1/4 (40)
G25	HH530H8001	Tension disc washer	1	
G26	HH531H8001	Tension release spring	1	
G27	HH532H8001	Tension thumb nut	1	

H. ACCESSORIES (1)

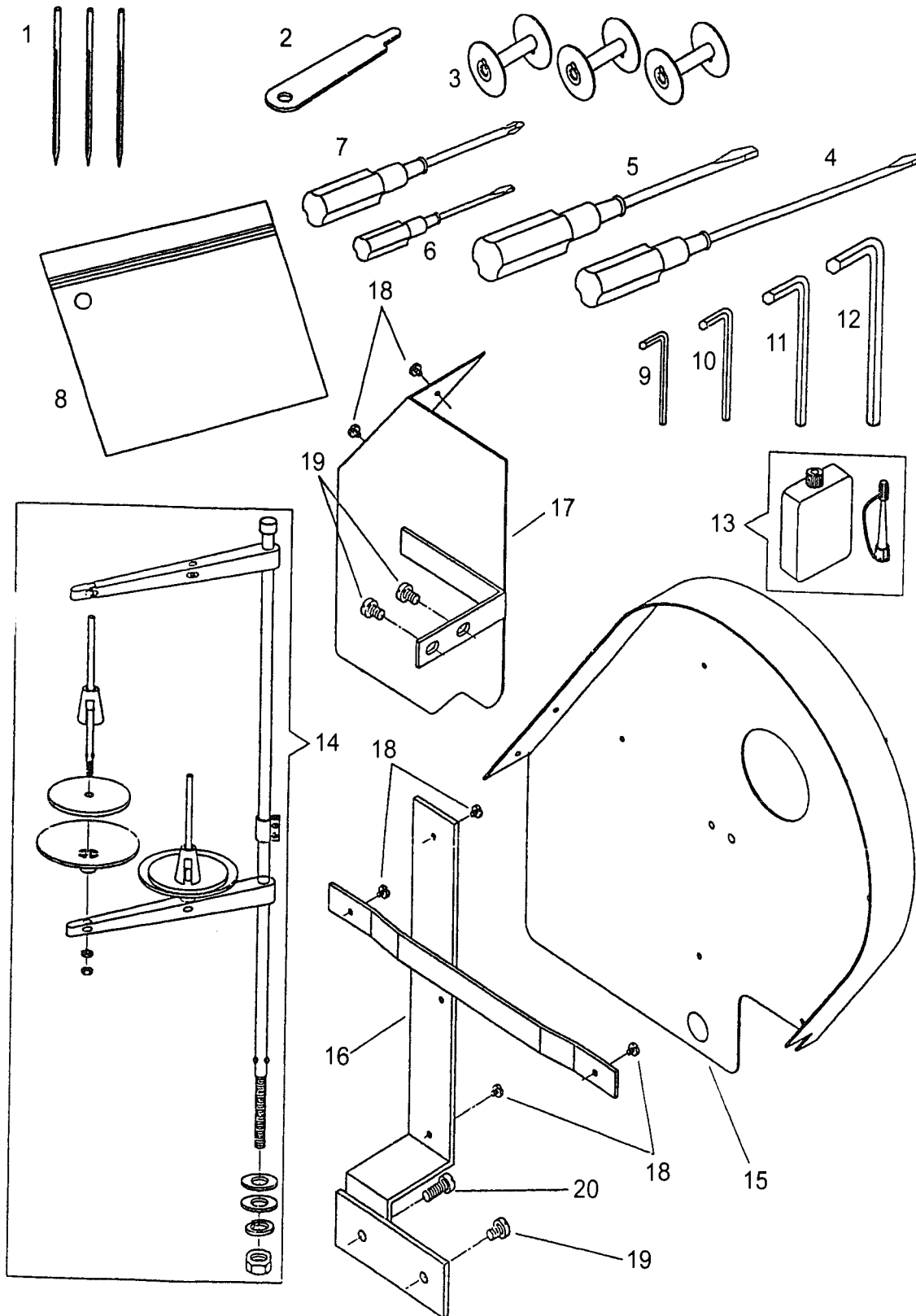

## H. ACCESSORIES (1)

Fig. No.	Part No.	Description	Pcs.	Remarks
H01	HH546C8001	Needle	3	SM×1000 (250/27)
H02	HH505I8001	Shuttle cylinder opener	1	
H03	HH506I8001	Bobbin	3	
H04	HA300J2070	Screw driver (large)	1	
H05	HA300J2200	Screw driver (middle)	1	
H06	HA300J2210	Screw driver (small)	1	
H07		Screw driver (cross type)	1	
H08	H7212K8001	Accessory bag	1	
H09	HB00001025	Hexagonal wrench (2.5mm)	1	
H10	HB00001030	Hexagonal wrench (3mm)	1	
H11	HB00001040	Hexagonal wrench (4mm)	1	
H12	HB00001050	Hexagonal wrench (5mm)	1	
H13	H200400069	Oiler	1	
H14	HA200J2030	Thread stand complete	1	
H15	HH518I8001	Belt guard body (1)	1	
H16	HH520I7101	belt guard stay	1	
H17	HH524I7101	Belt guard body (2)	1	
H18	HE123I8001	Screw	6	SM1/8(44)×4
H19	HH514H8001	Screw	3	SM17/64(24)×15
H20	HE040D8001	Screw	1	SM17/64(24)×17.5

I. ACCESSORIES (2)

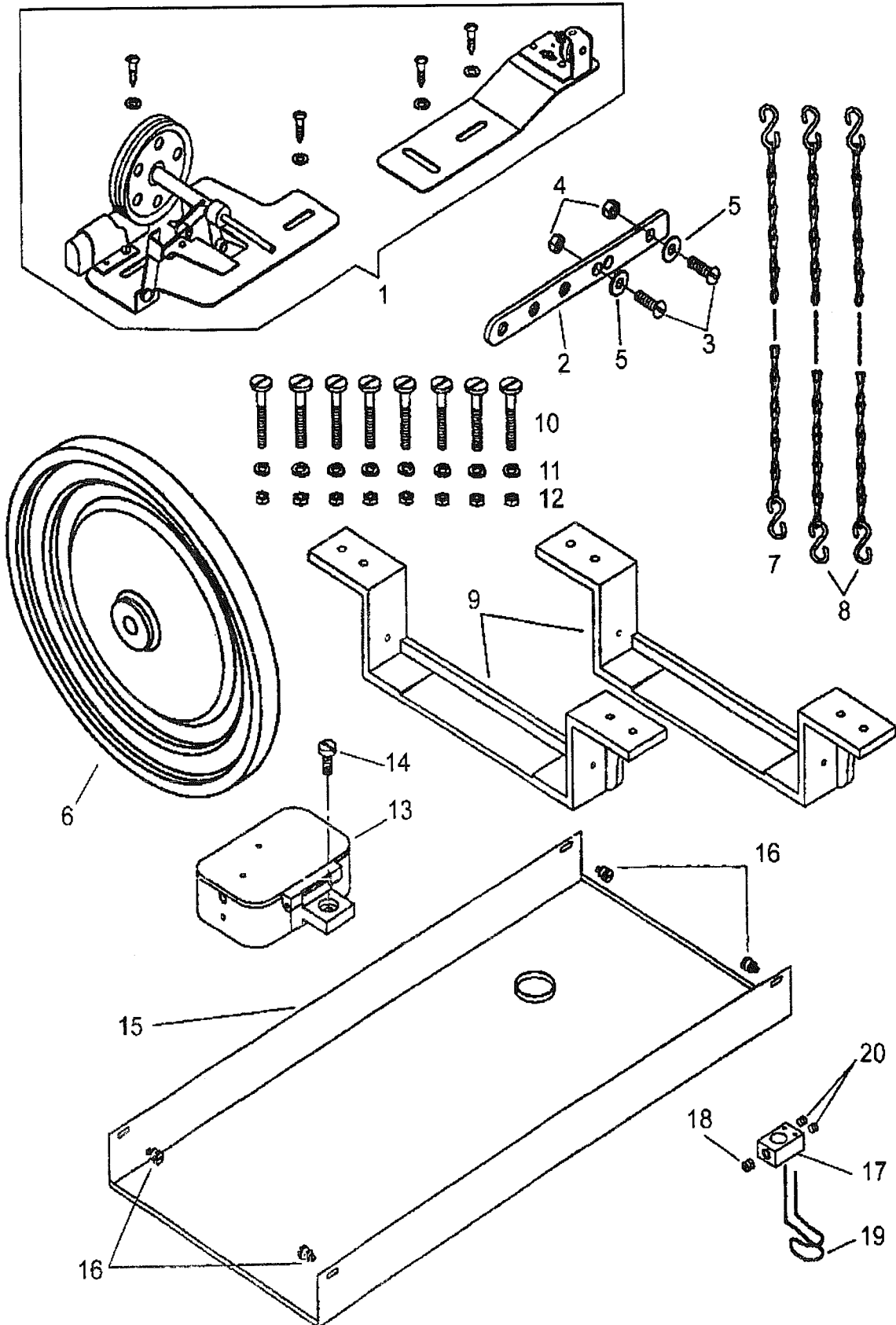

# I. ACCESSORIES (2)

Fig. No.	Part No.	Description	Pcs.	Remarks
I01	HH504J7101	Bobbin winder complete	1	
I02	HH524J8001	Motor lever extension	1	
I03	H402060200	Screw	2	M6 × 20
I04	H003001060	Nut	2	M6
I05	H005001064	Washer	2	
I06	HH528J8001	Pulley	1	
I07	HH524J8001	Chain(500)	3	
I08	HH524J8001	Chain(1000)	6	
I09	HH529J8001	Bed hinge	2	
I10	HH530J8001	Screw	8	SM5/16(18) × 65.5
I11	H005010080	Washer	8	
I12	HH531J8001	Nut	8	SM5/16(18)
I13	HH533J7101	Oil box complete	1	
I14	HA800F2020	Screw	1	SM15/64(28)
I15	HH526J8001	Oil pan	1	
I16	HH547J8001	Screw	4	SM13/64(32)
I17	HH510K8001	Finger guard base	1	
I18	HA305E0662	Screw	2	SM15/64 (28) × 4.5
I19	HH511K8001	Finger guard	1	
I20	H6039G8001	Screw	2	SM11/64(40) × 3.8



**SHANGHAI HUIGONG NO.3 SEWING MACHINE FACTORY**

**ADD: 1418, Yishan Road, Shanghai, China**

**Zip Code: 201103**

**Overseas Business: TEL: 86-21-64853303 FAX: 86-21-64854304**

**E-mail: [highlead@online.sh.cn](mailto:highlead@online.sh.cn) <http://www.highlead.com.cn>**

The description covered in this manual is subject to change for improvement of the commodity without notice

2005.1. Printed