

EasyLoop D

Vehicle detection sensor for activation or presence detection on automatic barrier systems

1 Description	2	4.2 Configure sensor	5
1.1 Function	2	4.3 Configure presence detection	5
1.2 Radar zone dimensions	2	4.4 Configure activation	6
1.3 Scope of delivery	2	5 Operation	6
2 Safety instructions	2	5.1 Status display	6
3 Installation	2	5.2 Troubleshooting	6
3.1 Mounting position	2	5.3 Troubleshooting	7
3.2 Mounting the sensor	3	5.4 Update firmware	7
3.3 Electrical connection	4	5.5 Maintenance	7
4 Settings	4	6 Technical data	8
4.1 Installing the app	4	7 Contact	8

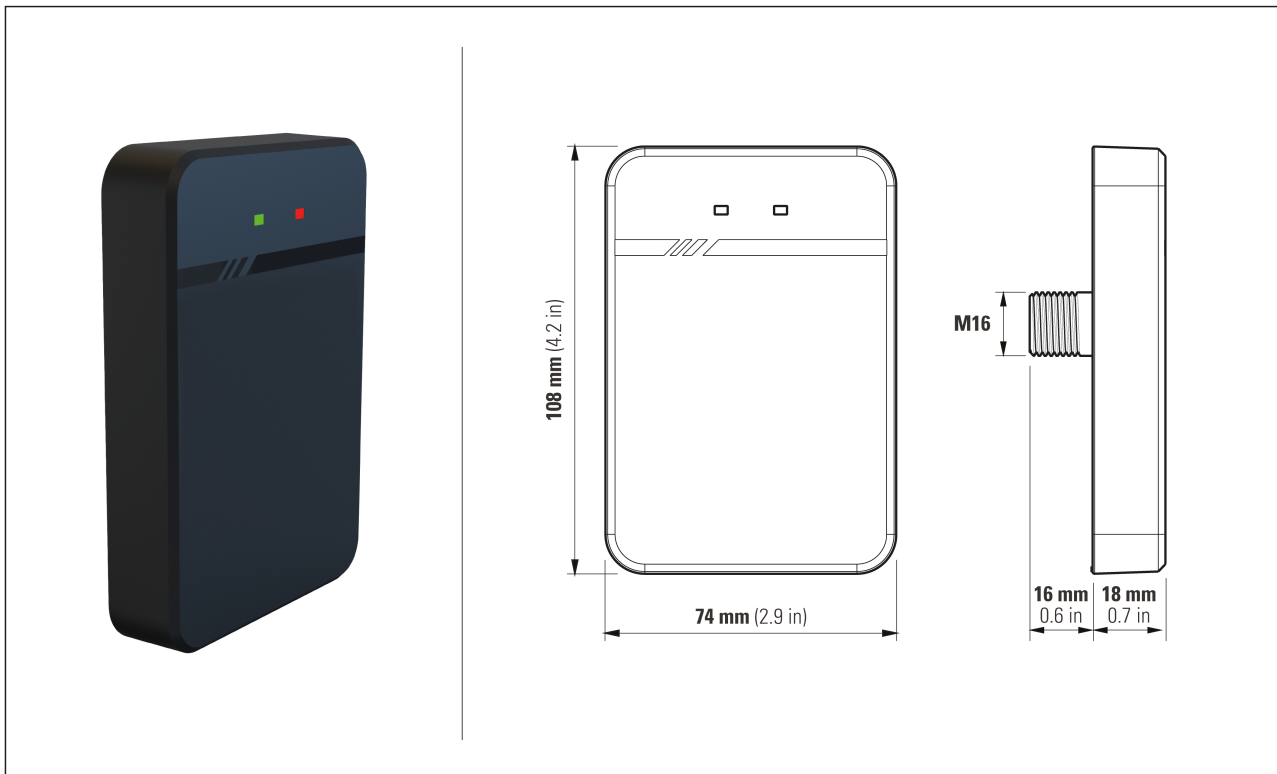

1 Description

1.1 Function

The sensor detects vehicles using radar technology. The device is designed for connection to the controller of automatic barrier systems.

The sensor can be used for:

- Presence detection for supplementary protection (type D in accordance with EN 12453) of a force-limited barrier arm
- **or** movement detection for activating the barrier

Aligning the radar field with the road:

- 90° for presence detection
- 90° or 45° for motion detection

1.2 Radar zone dimensions

Side view

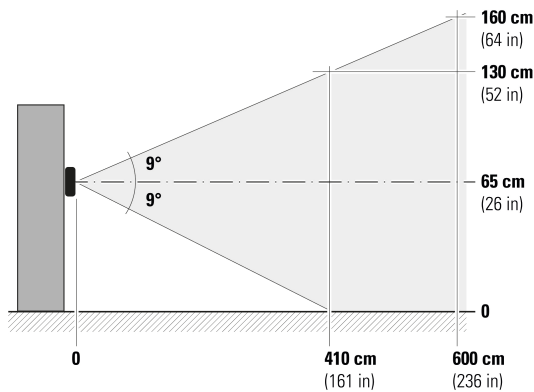

Top view

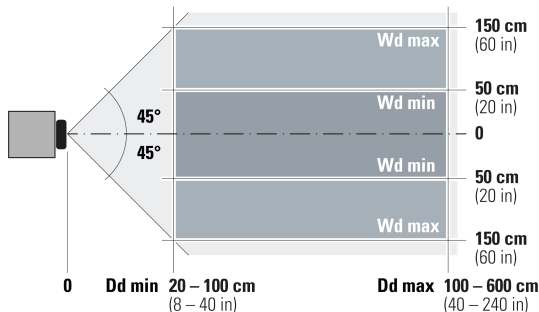

Wd detection width, configurable via mobile app
Dd detection distance, configurable via mobile app, default 300 cm (118 in)

1.3 Scope of delivery

1 sensor, 1 connection cable 10 pin × 1.2 m (4 ft), mounting material, instructions

Package dimensions: 140 × 85 × 60 mm

2 Safety instructions



Read the operating instructions carefully before commissioning the device. Keep the instructions for future use.

Intended use

The manufacturer is only liable for products used as intended. Only use this product for the following purpose:

Vehicle detection sensor for activation or presence detection on automatic barrier systems

Personnel qualification

Only trained and qualified personnel may install and commission the device.

The installer is responsible for installing the device and the connected system in accordance with the regulations and standards.

General safety instructions

It is the responsibility of the equipment installer to carry out a risk assessment and to install the system, in compliance with applicable regulations and safety standards.

The cables must be protected against mechanical damage.

3 Installation

3.1 Mounting position

Alignment to the road

The mounting position of the sensor depends on the intended function.

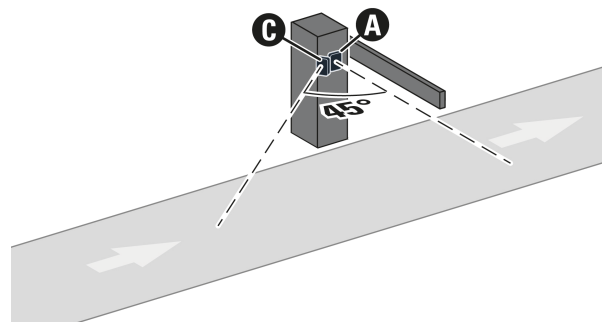
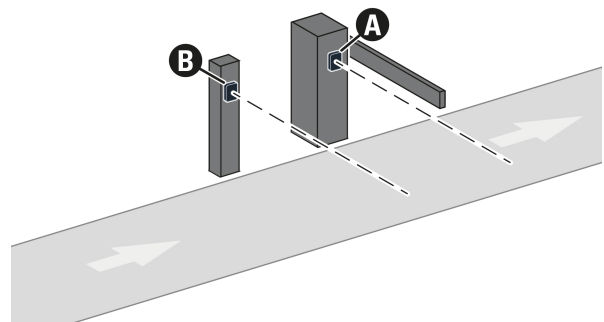

Protection sensor 90° (A):

- Presence detector for protection in the area of movement of the barrier arm
- Alignment crosswise to the road, parallel to the barrier arm
- Mounting on barrier housing

Activation sensor 90° (B):

- Motion detection for activating the barrier

- Detection of small distances between vehicles by alignment crosswise to the road
- Mounting on additional upstream post required

Activation sensor 45° (C):

- Motion detection for activating the barrier
- Detection only of large distances between vehicles by aligning diagonally to the road
- Mounting with bracket (optional accessory) at 45° angle on barrier housing possible

Mounting dimensions

A

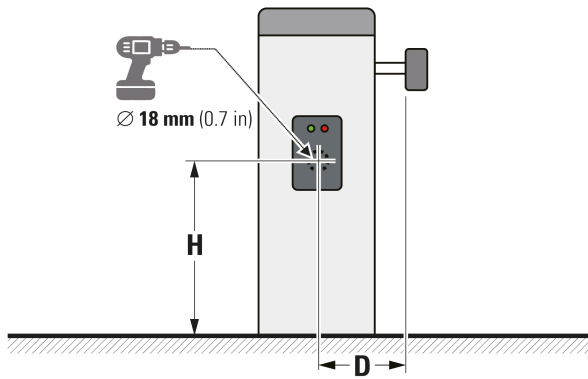

B

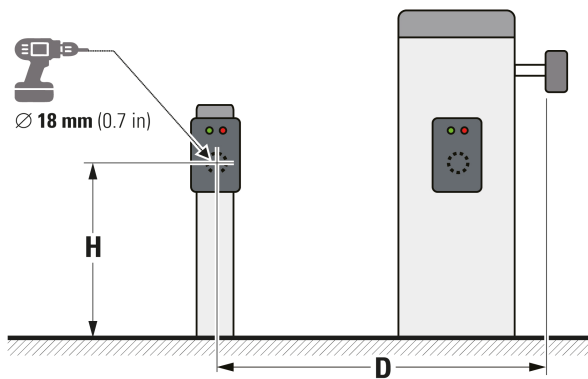

C

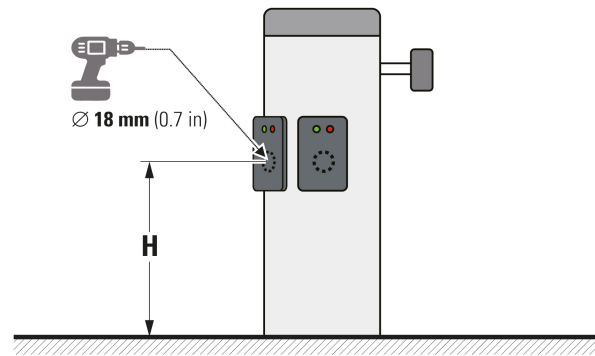

- H** Mounting height of sensor above road level:
- 65 – 75 cm (26 – 30 in) for small vehicles
 - 75 – 80 cm (30 – 32 in) for small vehicles in case of speed bumps or for trucks with chassis height > 70 cm (28 in)
 - Use of 2 sensors recommended for trucks with chassis height > 100 cm (40 in)
- D** Distance between the sensor and the barrier arm:
- 20 – 30 cm (8 – 12 in) for presence detector on barrier housing
 - > 180 cm (70 in) for activation sensor on post

! ATTENTION

- Avoid sources of interference (e.g. metal fences, walls, cameras) in the radar field.
- The effectiveness of the sensor may decrease in slushy or extreme weather (e.g. heavy rain or snowfall).

3.2 Mounting the sensor

Sensor arrangement 90° (A, B)

Mounting on the barrier housing or on the post:

- 1) At the intended position, drill a hole, Ø 18 mm (0.7 in), see section 3.1 "Mounting position".
- 2) Attach the sensor using the indicated mounting material.

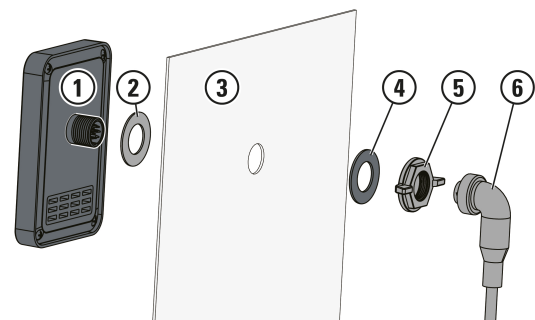

- 1 Sensor
- 2 Rubber seal
- 3 Barrier housing or post
- 4 Washer
- 5 M16 wing nut (5/8 in)
- 6 Connection plug

Sensor arrangement 45° (C)

Mounting with bracket (optional mounting kit):

- 1) Attach one side of the bracket in the intended position using the 5 self-tapping screws, see section 3.1 "Mounting position".
- 2) Fix the other side of the bracket in place using the hinge screws. Drill a cable passage, Ø 18 mm (0.7 in), in the barrier housing and insert the seal.
- 3) Attach the sensor to the bracket. Align the sensor.
- 4) Pull the cable through the cable passage. Insert the connector into the sensor.

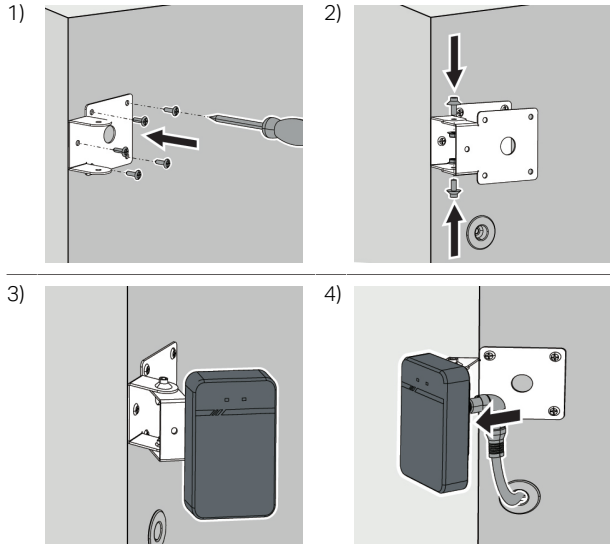

3.3 Electrical connection

- ▶ Connect the sensor to the barrier controller.

Wiring

	1	red	9 – 24 V DC	+
	2	black	GND	-
	3	blue	Output 1	NO
	4	green		
	5	brown	Output 2	NC
	6	violet		

Voltage connection

Note the polarity during the connection process.

- 1 red: + positive
- 2 black: - negative



ATTENTION

- ▶ Ensure a stable voltage source 9 – 24 V DC.
- ▶ A 12 V / 1 A power adapter with high inrush current withstand capability is recommended for optimal performance.

Connection for activation function

Output 1: NO (normally open)

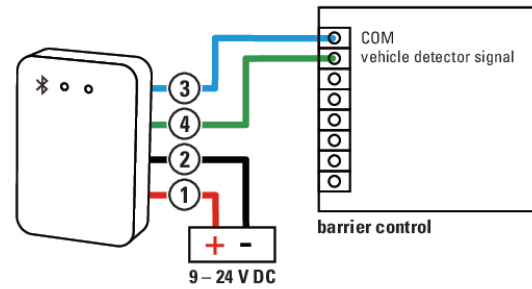

- 3 blue
- 4 green

Connection for presence detection

Output 2: NC (normally closed)

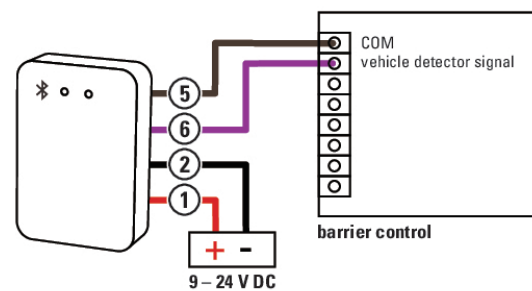

- 5 brown
- 6 violet

4 Settings

4.1 Installing the app



- 1) Scan the QR code.
- 2) Install the configuration app on your mobile end device.

The sensor is configured using the smartphone app (free of charge). The app requires access to the following services of the smartphone:

- Location services
- Bluetooth® connection
- Camera function

4.2 Configure sensor

Connect device

Menu: **Status**

- ▶ In the app, press the **Connect device** button.
- ▶ Select the desired sensor from the list of displayed Bluetooth® IDs.

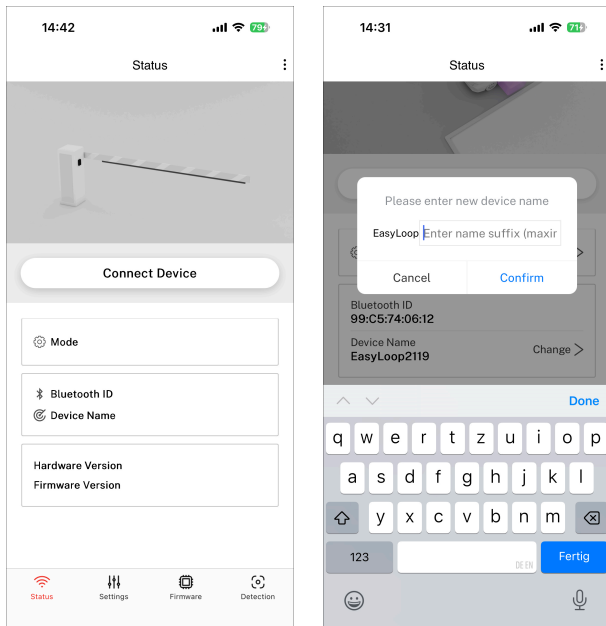

Set password

- ▶ Prevent unauthorized access to the sensor configuration by using a suitable password. The password is "88888888" in the factory setting. Replace the password with other digits (0 – 9). Keep the password safe.



NOTE

Lost password

If you have forgotten your password:

- ▶ Select the **Forgot password** option and contact the manufacturer to get the master password.

Set mode

Menu: **Status**

- ▶ Select the mode according to the intended sensor function.

- Presence detection
 - Sensor on barrier housing
 - Alignment 90° to the road
 - for protection in the area of movement of the barrier arm
- Activation
 - Sensor on post
 - Alignment 90° to the road
 - Motion detection
- Activation 45°
 - Sensor with bracket on barrier housing
 - Alignment 45° to the road
 - Motion detection

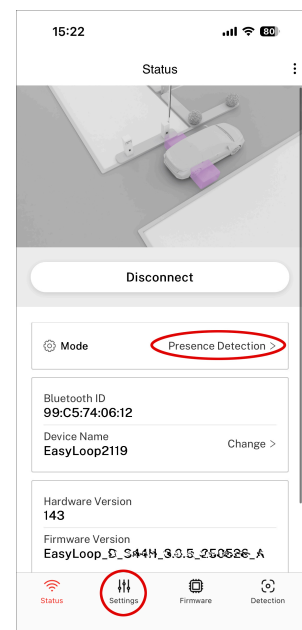

- ▶ Depending on the selected mode, make one of the following settings:

- 4.3 "Configure presence detection"
- 4.4 "Configure activation"

4.3 Configure presence detection

Configure settings

Menu: **Settings**

- ▶ Select road side and design of the barrier.
- ▶ Set the dimensions of the detection zone:

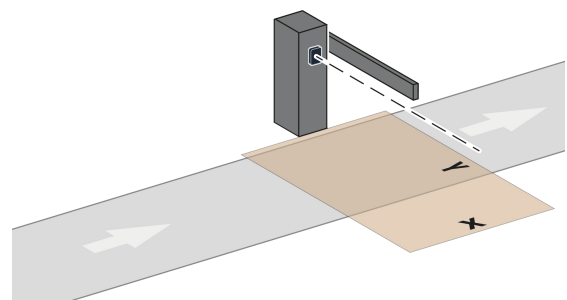

X Detection zone width

Y Detection zone length

50 cm (20 in) shorter than the length of the barrier arm

- ▶ Clear the detection zone. Bring the barrier arm into an upright position.
- ▶ Send the settings to the sensor. This begins the teach-in process.

Teach-in

The duration of the teach-in process depends on the design of the barrier arm.

Straight arm

Duration: 2 – 3 seconds

- ▶ Keep the detection zone free of traffic.



Arm with special equipment

Duration: 30 – 60 seconds

- ▶ Keep the detection zone free of traffic.
- ▶ Trigger some opening and closing cycles with the remote control.



Detection

After completing teach-in, select **View objects** to visualize detection.

Do not perform any other actions (except **Stop display**).

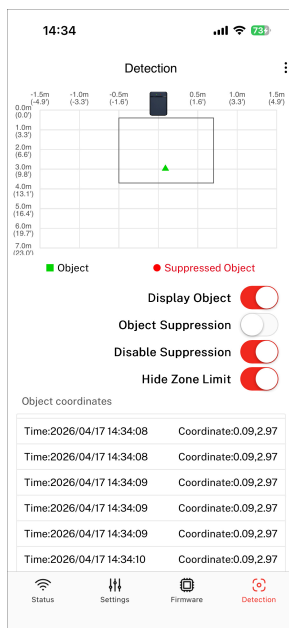

When objects are detected, press the **Stop display** button and then **Object suppression** before proceeding to normal operation.

4.4 Configure activation

Configure settings

Menu: **Settings**

- ▶ Provide information on the road side of the barrier.
- ▶ Select the direction of movement of the vehicles that will activate the barrier.
- ▶ Set the dimensions of the detection zone:

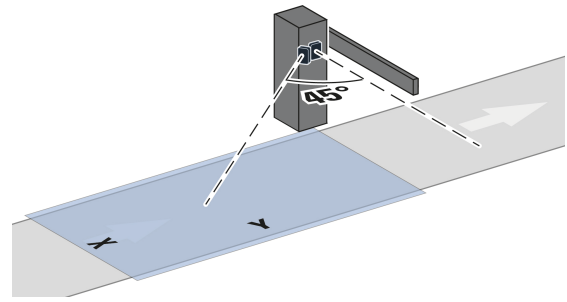
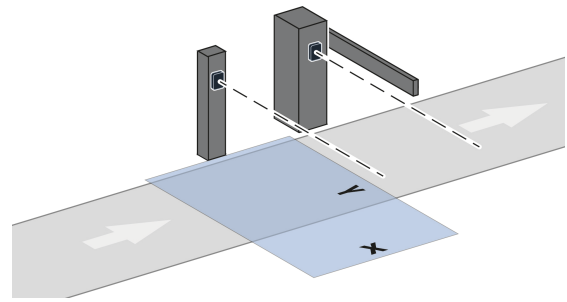

X Detection zone width

Y Detection zone length

50 cm (20 in) shorter than the length of the barrier arm with 90° arrangement

Road width with 45° arrangement

- ▶ To detect pedestrians, select the high sensitivity.

5 Operation

5.1 Status display

LED display		Operating status
red	on	standby
green	on	detection
green	flashing	in progress

5.2 Troubleshooting

Fault

Possible cause	Possible measure
Wrong power adapter	▶ Ensure a stable voltage source 9 – 24 V DC. A 12 V / 1 A power adapter with high inrush current withstand capability is recommended for optimal performance.

LEDs on, sensor not shown in app

- ▶ Ensure a stable voltage source 9 – 24 V DC. A 12 V / 1 A power adapter with high inrush current withstand capability is recommended for optimal performance.

System failed, power indicator (red LED) off

Power supply failed	▶ Provide a stable power source.
Wrong connection voltage	▶ A 9 – 24 V DC power source is required, preferably 12 V/1 A.

Sensor not shown in app

Smartphone too far away	▶ Reduce the distance to max. 1 m.
Sensor already connected to another device	Multiple connection is not possible. ▶ Disconnect the redundant device.

Correctly displayed detection (green LED), barrier function incorrect

Incorrect configuration of barrier controller.	▶ Correct the configuration according to the instructions of the barrier controller.
Incorrect connection to barrier controller.	▶ Correct the connection according to section "Electrical connection" .
Reverse switching logic	▶ Change the switching logic NO/NC according to section "Electrical connection" .

Correctly displayed detection (green LED), power indicator (red LED) illuminated

Background interference	▶ Repeat the teach-in process.
Detection zone too short	▶ Increase the detection depth.

Unintentional detection of pedestrians

Sensitivity too high	▶ Adjust the sensitivity using the app.
Pedestrians with large luggage or metal objects are passing through the detection zone.	▶ Redirect pedestrian traffic.
Groups of pedestrians are passing through the detection zone.	

Barrier opens and closes in quick succession

Detection depth too high	▶ Reduce the detection depth.
Activation sensor detects barrier movement	▶ Alignment of the activation sensor 90°: Increase the distance of the sensor to the barrier arm to at least 3 m (12 ft). ▶ Alignment of the activation sensor 45°: Increase the angle of the sensor to the barrier arm.
Barrier arm equipped with cover or curtain	▶ Remove the equipment.

5.3 Troubleshooting

For troubleshooting, you will find further options and information in the menu at the top right, e.g.:

- Error report
- Event log
- Remote debugging

If necessary, contact:
Bircher Technical support

✉ service@bircher.com
☎ +41 52 687 1366

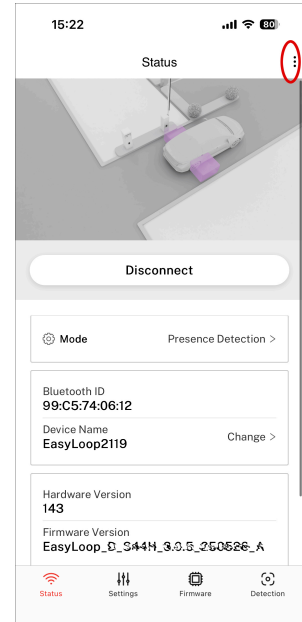

5.4 Update firmware

To update the firmware, select the **Firmware** button below, download the latest firmware version, and perform the online installation.

If necessary, you can get help from:
Bircher Technical Support

✉ service@bircher.com
☎ +41 52 687 1366

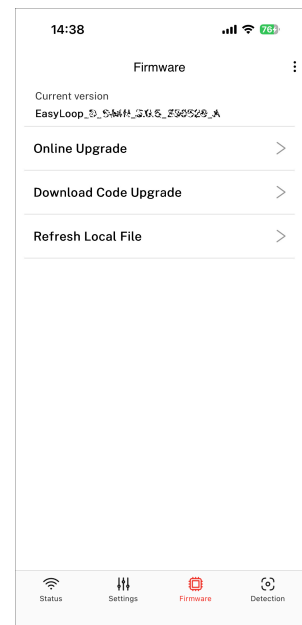

5.5 Maintenance

Ongoing

- ▶ To avoid operational interference, keep the sensor surface clean from debris (e.g., caused by water, snow, dust).
- ▶ In case of environmental changes: if objects (e.g., guide columns, traffic cones) are added to the detection area, repeat the teach-in process.

Every six months

- ▶ Test the functionality of the system.
- ▶ Ensure that the cables are undamaged.

6 Technical data

Functional data

Function	Safety (presence detection) Activation (motion detection)
Technology	Radar 79 GHz
Detection field (L × W)	90°: 6 m × 3 m (20 ft × 10 ft) 45°: 6 m × 4 m (20 ft × 13 ft)
Detection depth (adjustable)	Lower limit: 20 – 100 cm (8 – 40 in) Upper limit: 100 – 600 cm (40 – 240 in)
Detection width (adjustable)	Per side: 50 – 150 cm (20 – 60 in)
Configuration	Via smartphone app
Interface	Bluetooth®/RS485

Mechanical data

Housing material	PC, PBT, GF20, ABS
Dimensions (L × W × D)	108 × 74 × 18 mm (4.25 × 2.9 × 0.7 in)
Weight	131 g (4.7 oz)
Protection class	IP66

Electrical data

Operating voltage	9 – 24 V DC (preferably 12 V/1 A)
Power consumption	< 2.5 W
Output	2 relays NO, NC
Response time	100 ms
Connection cable	10-pin
Cable length	1.2 m (3.9 ft)

Ambient conditions

Operating temperature	Min. –40 °C, max. 85 °C (min. – 40 F, max. 185 F)
-----------------------	--

Disposal information



The product contains electrical or electronic components. Do not dispose of the product with household waste.

Notice on conformity



BBC Bircher AG declares that this product conforms with the following guidelines and directives of the EU:

RED 2014/53/EU RoHS 2011/65/EU

For the detailed Declaration of Conformity, follow the QR code or link below.

Technical documentation



You will find all documents on the manufacturer website
www.bircher.com

7 Contact

If you have any questions about the device, please contact us:

✉ service@bircher.com ☎ +41 52 687 1366

BBC Bircher Smart Access

BBC Bircher AG, Wiesengasse 20, CH-8222 Beringen
www.bircher.com