

R.BIRD

Copyright notice

This document is ©Copyright 2005, R.BIRD & Company, Inc. and cannot be reproduced, distributed or otherwise published without written permission from R.BIRD & Company, Inc.

R.BIRD & Company, Inc. or its clients claim all rights, title and interest to original intellectual properties and information contained in this document pertaining to, but not limited to: copyright, trademarks, packaging, advertising, marketing, formulae, models, processes, procedures, methods, documents, ideas, concepts, new products, improvements, inventions, research or associations except where such content may already be copyright or property of any third party.

Any representation in this document of copyright or property of any third party is included in this document for educational purposes and remains the property of its respective copyright owners.

What we do as designers is
make observations
about how the customer
chooses and uses the product.

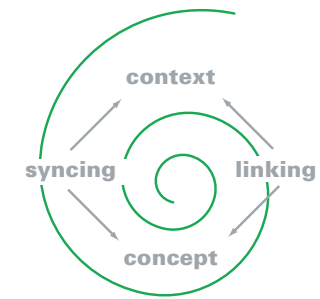

From these discoveries we
frame a context
that articulates an expanded picture
of the customer's needs and desires.

In response to these discoveries
we create an expanded group of informed solutions
that exhibit a remarkable level of innovation
all which pointedly address the context of the product.

R.BIRD design and marketing clients benefit from PROCEDE (our method for exploring creative strategies and greater possibilities) in several ways. We've highlighted a few of them below.

1. New ways to uncover relevant and innovative possibilities

We start with your project goals, then expand on them to look at consumers and their lives in a larger context. Exercises we've developed help us better understand related wants and needs, thinking and behavior. Reacting to these discoveries enables us to consider multiple points of view and come up with more innovative design directions than we could have without such a broad perspective. This reflects a recurring theme with PROCEDE: greater possibilities.

2. More options to consider (way more)

How many times have you looked at design options and wished you had more to work with? PROCEDE uses a method we call "creative parallel processing". What that means is a whole team of designers in our studio works on your project. Everyone brainstorms possibilities. They vote in everything they think is a relevant, potential solution. You get to see them all, and decide for yourself which ones answer your criteria in the most innovative way.

3. Not just design concepts, but a toolset to help find the right direction

The purpose of presenting ideas in the different PROCEDE formats is to encourage and facilitate discussion and decision making. You, the client, are brought into the formative stage of the design process and given several different ways to review and edit the potential options. Everyone involved works with a common set of visual reference points.

4. A range of concepts that allows for (and even answers) changing criteria

You've been there. Somewhere between the time the project starts and the time it's due, someone changes the criteria 180°. The beauty of the range of submissions with PROCEDE is that if the criteria changes, you already have a set of alternative designs which can easily become the jumping off point for the inevitable "where do we go now" discussions.

5. A bridge between marketing, strategy and design

PROCEDE helps translate words and ideas into visual expressions that all team members can see and talk about. Innovation, Marketing, Brand, and Design can share results in a way that all can easily and instantly understand. The effect is a potentially more collaborative, integrated and communicative process - regardless of stage or scale.

Zensa

Performance. Technology. Science.

For those who live at life's extremes, this brand provides quick relief from the rigors of an active lifestyle.

Dynamic shapes, bold imagery, and strong colors appeal to one's sense of accomplishment and endurance, re-assuring them that this brand is as demanding technologically as they are physically.

Caring. Comfort. Relief.

From the everyday ache to the work-a-day pain, this brand provides the caring relief one needs to feel their best.

Soft shapes, light-filled spaces, and calm colors provide a feeling of home, the soothing comfort of a mother's touch, and a sense of security knowing that high quality care will help them get back to their pain-free self.

Zensa. This highly unusual, compact word made from "Zen" and "Sensation" is also onomatopoeic (it's pronunciation is "zen-like" and soothing).

Primary Keywords

Zensa

quality, family, convenience, renown

performance, technology, science

cooling, warming

5 Why's *Expanding the context to get to the deeper, root motivations*

Why do you buy this product?

To help relieve the pain in my shoulder.

Why do you want to relieve the pain in your shoulder?

Because it effects my ability to do my job well.

Why is that important to you?

If I slow down at work, that's just one more reason to hire someone else to take my place.

Why does it matter if someone else takes your job?

If someone else takes my job, then who will pay my bills?

Why is it important for you to pay your bills?

Because it gives the security and peace of mind in knowing that everything will be okay.

Why do you buy this product?

You never know when someone's going to get hurt or when my arthritis will act up. I like to keep it on hand just in case.

Why don't you wait until something happens to buy it? Why keep it on hand?

Because It's always better to be prepared.

Why is it better to be prepared?

So I can rest easier knowing everything will be okay.

Why do you want to know everything will be okay?

Because I'm responsible for the welfare of my family.

Why is that important?

It's my way of showing that I care about my family. It makes me feel like I'm being a good parent.

Why do you buy this product?

I hurt my knee and it helps me get back up to speed.

Why do you want to get back up to speed?

I'm an athletic person, and being injured really takes its toll on my performance.

Why is performance so important to you?

The better I perform, the stronger I feel.

Why do you want to feel stronger?

Because that feeling of strength makes me believe I can accomplish my goals.

Why is it important for you to accomplish you goals?

Accomplishing my goals helps me feel better about my self and my life, it gives me a sense of pride in everything I do.

Caring, Comfort, Security

Performance

Keywords in Context

Caring

Protection
Loving
Motherhood
Gentle
Security
Touch
Thoughtful
Family
Home
Soft
Friendship
Hospital
Relief
Doctor
Tradition
Red Cross
Comfort
Wellness
Therapy

Performance

High Energy
Drive
Prepare
Motivated
Ambition
Ready
Endurance
Science
Accomplish
Strong
Proud
Technology
Determination
Repeatable
Machinery
Triumph
Speed
Professional

Discovering Direction - *Performance*

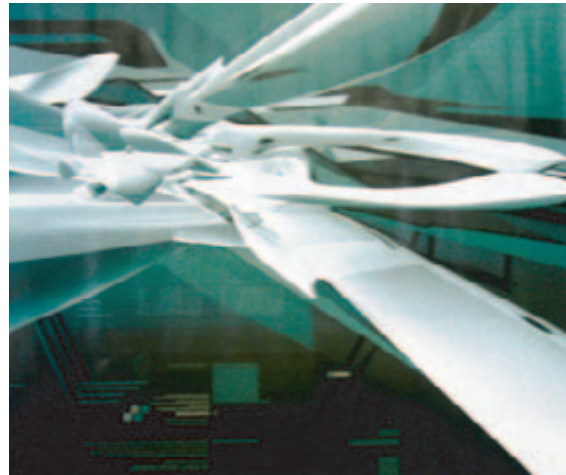

High Energy
Drive
Prepare
Motivated
Ambition
Ready
Endurance
Professional

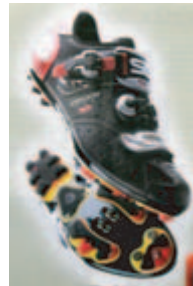

Science
Accomplish
Strong
Proud
Technology
Determination
Repeatable
Machinery
Triumph
Speed

Performance. Technology. Science.

For those who live at life's extremes, this brand provides quick relief from the rigors of an active lifestyle.

Dynamic shapes, bold imagery, and strong colors appeal to one's sense of accomplishment and endurance, re-assuring them that this brand is as demanding technologically as they are physically.



Discovering Direction - *Caring*



Protection
Loving
Motherhood
Gentle
Security
Touch
Thoughtful

Caring. Comfort. Relief.

From the everyday ache to the work-a-day pain, this brand provides the caring relief one needs to feel their best.

Soft shapes, light-filled spaces, and calm colors provide a feeling of home, the soothing comfort of a mother's touch, and a sense of security knowing that high quality care will help them get back to their pain-free self.

Family
Home
Soft
Friendship
Hospital
Relief
Doctor
Tradition
Red Cross
Comfort
Wellness
Therapy

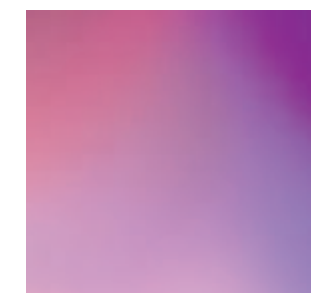

Results

Our design phase produced a total of 10 potential design candidates. We have provided these solutions in various forms so you can evaluate/compare/contrast and ultimately edit them down to those that best fit your strategy.

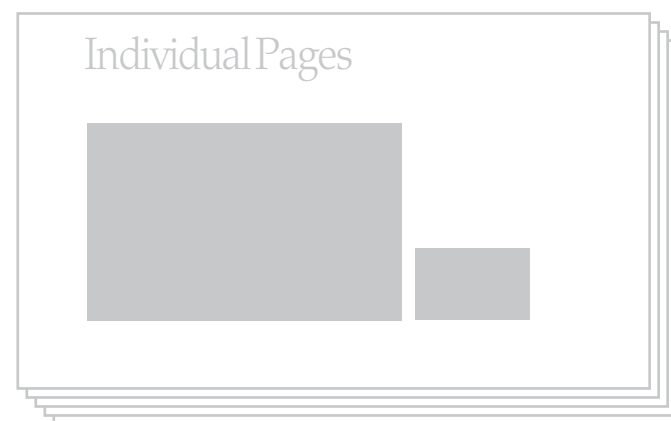
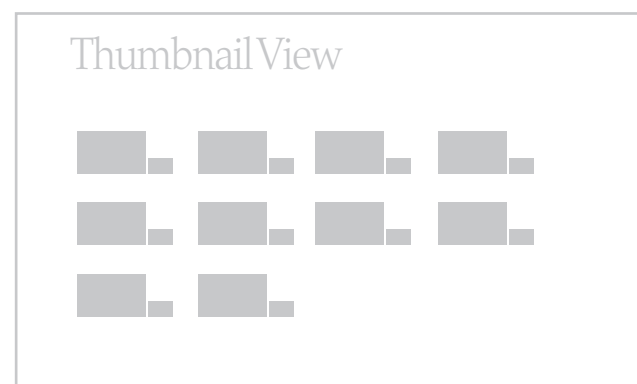

4x6 Cards

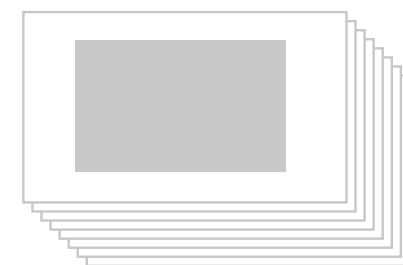

A Bird's Eye View



01



02

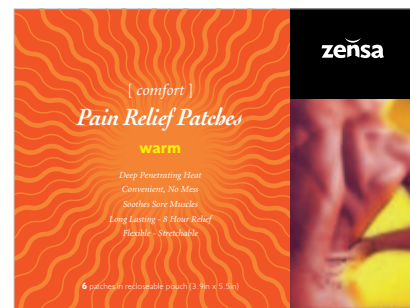

03

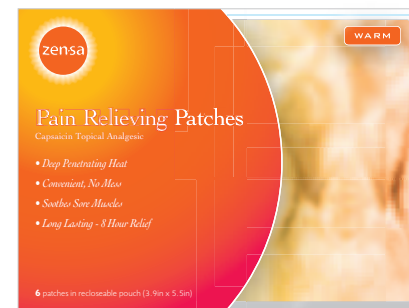

04



05

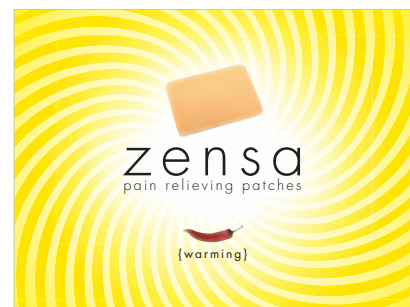

06

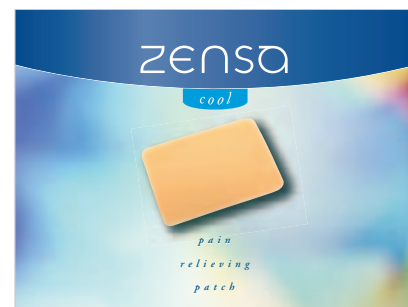

07



08



09

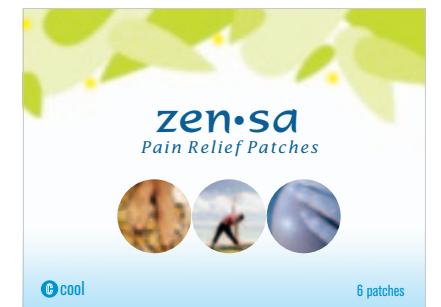

10



Performance. Technology. Science.

For those who live at life's extremes, this brand provides quick relief from the rigors of an active lifestyle.

Dynamic shapes, bold imagery, and strong colors appeal to one's sense of accomplishment and endurance, re-assuring them that this brand is as demanding technologically as they are physically.

Caring. Comfort. Relief.

From the everyday ache to the work-a-day pain, this brand provides the caring relief one needs to feel their best.

Soft shapes, light-filled spaces, and calm colors provide a feeling of home, the soothing comfort of a mother's touch, and a sense of security knowing that high quality care will help them get back to their pain-free self.



Performance. Technology. Science.

For those who live at life's extremes, this brand provides quick relief from the rigors of an active lifestyle.

Dynamic shapes, bold imagery, and strong colors appeal to one's sense of accomplishment and endurance, re-assuring them that this brand is as demanding technologically as they are physically.

Caring. Comfort. Relief.

From the everyday ache to the work-a-day pain, this brand provides the caring relief one needs to feel their best.

Soft shapes, light-filled spaces, and calm colors provide a feeling of home, the soothing comfort of a mother's touch, and a sense of security knowing that high quality care will help them get back to their pain-free self.



Performance. Technology. Science.

For those who live at life's extremes, this brand provides quick relief from the rigors of an active lifestyle.

Dynamic shapes, bold imagery, and strong colors appeal to one's sense of accomplishment and endurance, re-assuring them that this brand is as demanding technologically as they are physically.

Caring. Comfort. Relief.

From the everyday ache to the work-a-day pain, this brand provides the caring relief one needs to feel their best.

Soft shapes, light-filled spaces, and calm colors provide a feeling of home, the soothing comfort of a mother's touch, and a sense of security knowing that high quality care will help them get back to their pain-free self.



Performance. Technology. Science.

For those who live at life's extremes, this brand provides quick relief from the rigors of an active lifestyle.

Dynamic shapes, bold imagery, and strong colors appeal to one's sense of accomplishment and endurance, re-assuring them that this brand is as demanding technologically as they are physically.

Caring. Comfort. Relief.

From the everyday ache to the work-a-day pain, this brand provides the caring relief one needs to feel their best.

Soft shapes, light-filled spaces, and calm colors provide a feeling of home, the soothing comfort of a mother's touch, and a sense of security knowing that high quality care will help them get back to their pain-free self.

Clearfold carton, decorated pouch with illustration

zensa

WARM

pain relieving patch



zensa

COOL

pain relieving patch



Performance. Technology. Science.

For those who live at life's extremes, this brand provides quick relief from the rigors of an active lifestyle.

Dynamic shapes, bold imagery, and strong colors appeal to one's sense of accomplishment and endurance, re-assuring them that this brand is as demanding technologically as they are physically.

Caring. Comfort. Relief.

From the everyday ache to the work-a-day pain, this brand provides the caring relief one needs to feel their best.

Soft shapes, light-filled spaces, and calm colors provide a feeling of home, the soothing comfort of a mother's touch, and a sense of security knowing that high quality care will help them get back to their pain-free self.



Performance. Technology. Science.

For those who live at life's extremes, this brand provides quick relief from the rigors of an active lifestyle.

Dynamic shapes, bold imagery, and strong colors appeal to one's sense of accomplishment and endurance, re-assuring them that this brand is as demanding technologically as they are physically.

Caring. Comfort. Relief.

From the everyday ache to the work-a-day pain, this brand provides the caring relief one needs to feel their best.

Soft shapes, light-filled spaces, and calm colors provide a feeling of home, the soothing comfort of a mother's touch, and a sense of security knowing that high quality care will help them get back to their pain-free self.

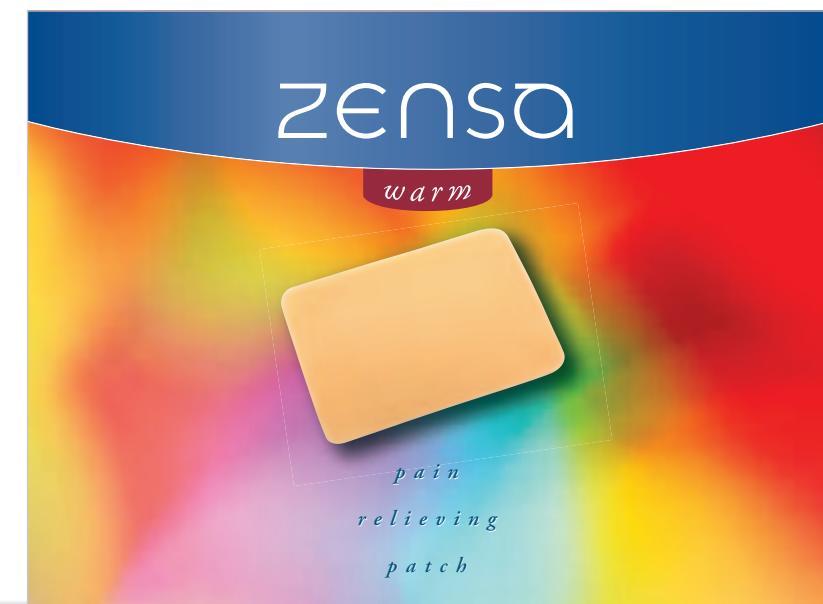

Performance. Technology. Science.

For those who live at life's extremes, this brand provides quick relief from the rigors of an active lifestyle.

Dynamic shapes, bold imagery, and strong colors appeal to one's sense of accomplishment and endurance, re-assuring them that this brand is as demanding technologically as they are physically.

Caring. Comfort. Relief.

From the everyday ache to the work-a-day pain, this brand provides the caring relief one needs to feel their best.

Soft shapes, light-filled spaces, and calm colors provide a feeling of home, the soothing comfort of a mother's touch, and a sense of security knowing that high quality care will help them get back to their pain-free self.

Stock Photography - Images to be re shot or purchased

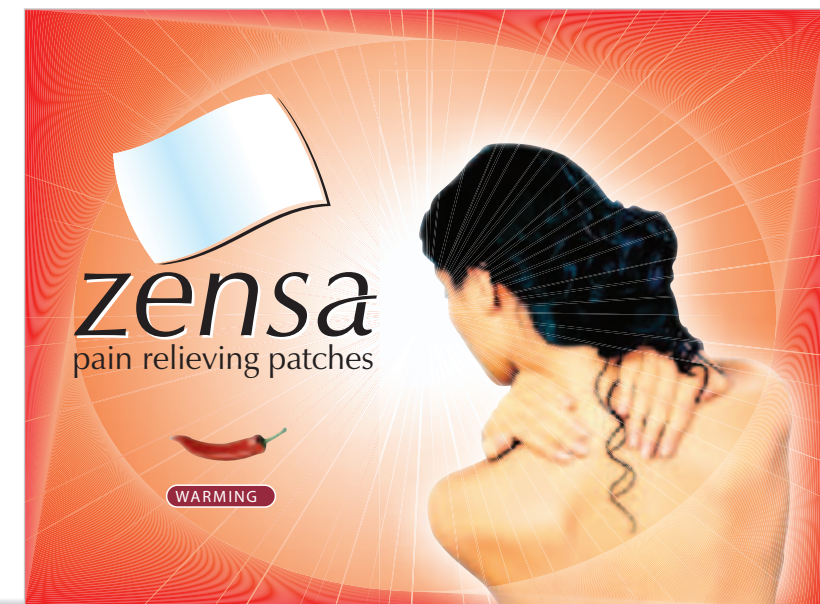

Performance. Technology. Science.

For those who live at life's extremes, this brand provides quick relief from the rigors of an active lifestyle.

Dynamic shapes, bold imagery, and strong colors appeal to one's sense of accomplishment and endurance, re-assuring them that this brand is as demanding technologically as they are physically.

Caring. Comfort. Relief.

From the everyday ache to the work-a-day pain, this brand provides the caring relief one needs to feel their best.

Soft shapes, light-filled spaces, and calm colors provide a feeling of home, the soothing comfort of a mother's touch, and a sense of security knowing that high quality care will help them get back to their pain-free self.

Stock Photography - Images to be re shot or purchased



Performance. Technology. Science.

For those who live at life's extremes, this brand provides quick relief from the rigors of an active lifestyle.

Dynamic shapes, bold imagery, and strong colors appeal to one's sense of accomplishment and endurance, re-assuring them that this brand is as demanding technologically as they are physically.

Caring. Comfort. Relief.

From the everyday ache to the work-a-day pain, this brand provides the caring relief one needs to feel their best.

Soft shapes, light-filled spaces, and calm colors provide a feeling of home, the soothing comfort of a mother's touch, and a sense of security knowing that high quality care will help them get back to their pain-free self.

Stock Photography - Images to be re shot or purchased



Performance. Technology. Science.

For those who live at life's extremes, this brand provides quick relief from the rigors of an active lifestyle.

Dynamic shapes, bold imagery, and strong colors appeal to one's sense of accomplishment and endurance, re-assuring them that this brand is as demanding technologically as they are physically.

Caring. Comfort. Relief.

From the everyday ache to the work-a-day pain, this brand provides the caring relief one needs to feel their best.

Soft shapes, light-filled spaces, and calm colors provide a feeling of home, the soothing comfort of a mother's touch, and a sense of security knowing that high quality care will help them get back to their pain-free self.

Stock Photography - Images to be re shot or purchased

Appendix

We gather a lot of information throughout the design process that helps shape our thinking. As an added benefit to you, we have provided some of that information in the following pages so you can make better decisions relevant to your strategic goals.

Competing Products



Related Products



In Context



Place postcard here to compare your selection to competitors



Structure - Observations

Popular Brands



BENGAY
Largest face panel.
7.125w x 5.5h x .973d.
Large shape and narrow depth lead to instability.



ICYHOT
Medium face panel.
5.75w x 5h x 1.5d.
Optimum dimensions for vertical or horizontal decoration.



ABSORBINE JR
3.25w x 6h x 2.25d.
Vertical carton loses connection with product typically sold in rectangular flat boxes.

Environment



Shelf height is at a premium especially in chain drug stores like CVS and RiteAid.



Boxes are stacked incorrectly when they are too wide for slotted areas or shelves with dividers.



Bengay cartons are somewhat large and are often seen tipped over or shelved incorrectly. The height makes it difficult to take from a 6" shelf.

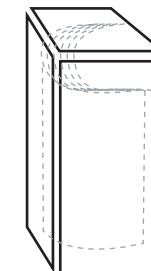

Absorbine Jr. patches get lost due to the unconventional package – identical to the liquid. The patches are rolled up in the box which could cause the backing to peel away from the patch.

Structure - *Recommendation*

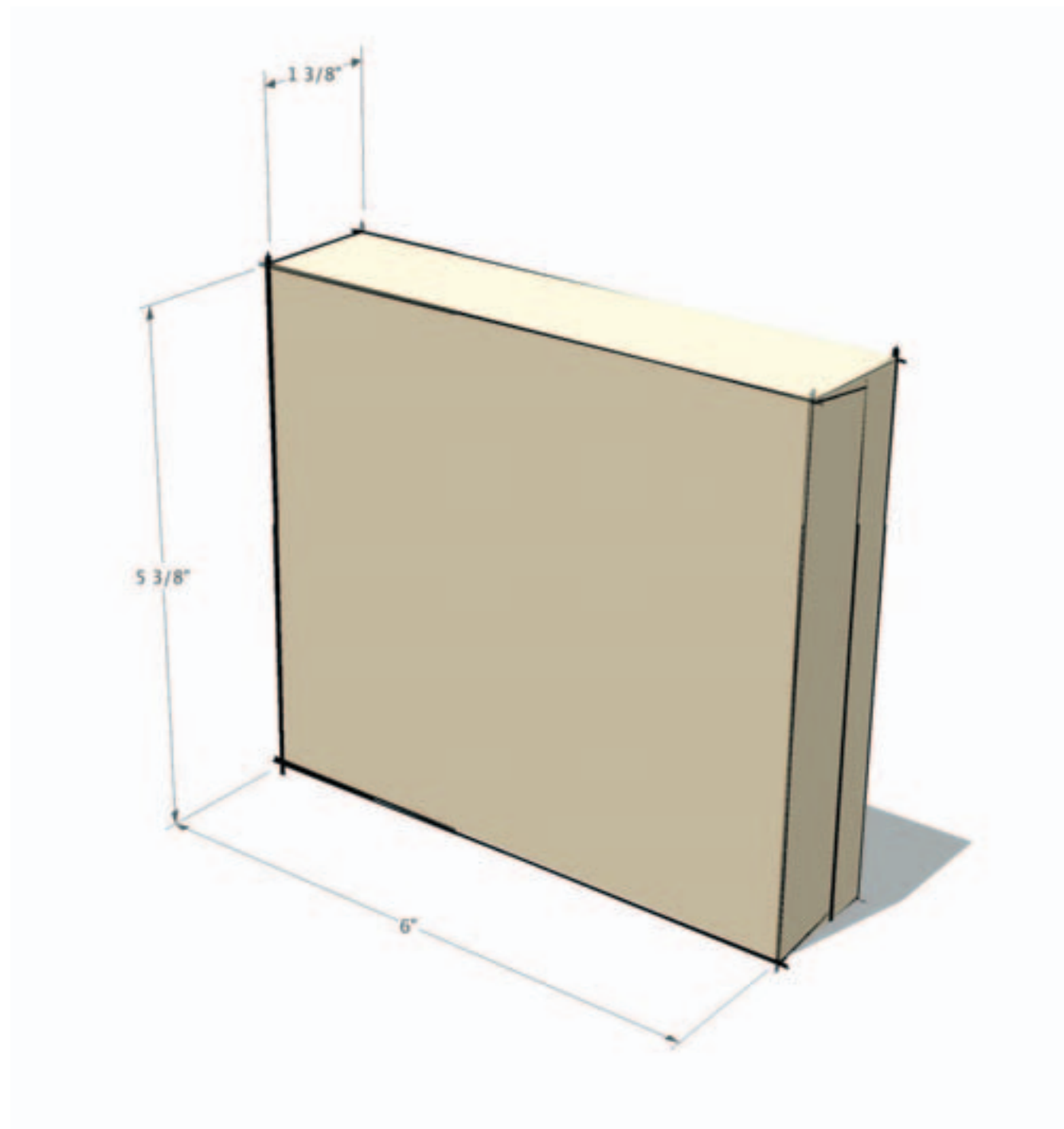

Beveled edge adds a unique feature.

Hang tag back provides more display options

Pop-up hang tag is an another alternative

Dimensions are slightly larger than ICYHOT and deep enough to ensure stability. Glued end flaps are resealable on left side. Carton can be decorated vertically or horizontally.

About R.BIRD

Brand & Package Design

R.BIRD plays a vital and strategic role in the life cycle of domestic and global brands.

We create the visual assets on which marketplace success of consumer products depends.

We accomplish this in a wide range of brand strategy and design services, including new product concepts and redesigns of established brands and packaging.

Services Include:

Brand & Package Redesign

Brand Innovation & Strategy

Brand Marketing Support

Category Design Audit

Form & Structure

Name Building

New Product Packaging

Package Line Extension

Package Production & Maintenance

Brand Website

About R.BIRD

R.BIRD & Company, Inc. is a New York identity and design consulting firm with more than 20 years of experience creating brand identity, packaging, corporate identity and internet applications. Its clients are internationally-recognized brands and strategy-oriented organizations.