

Laminex® Aquapanel®

Laminex Aquapanel is a melamine surfaced high-pressure decorative laminate specifically designed for areas where resistance to moisture is required. The strong and durable 2.7mm sheets feature a black core allowing the distinctive black edge to be exposed in applications.



Laminex® Aquapanel® has a moisture resistant backing, and a balanced construction ensures board flatness. It has excellent impact strength, which is more than adequate for normal applications, enabling supporting framework to be spaced at 450mm centers. It is available in a range of finishes and colours / patterns.

APPLICATIONS

Laminex Aquapanel is ideal for:

- Lining in shower recesses, bathrooms, and laundries,
- Splashbacks over sinks, basins and laundry troughs
- Lining buses, caravans and boats.
- Shopfitting and commercial applications
- Wall Panelling and Partitioning

Although Laminex Aquapanel is designed for use in wet areas, this material must not be immersed in water for lengthy periods nor should it be continuously exposed to saturated moisture conditions.

Decors and Patterns

Refer to current Laminex Aquapanel brochure for decors and patterns available.

Accessories

Refer to Section 5:28 for Fixing Systems Product information. Refer to Section 5:33 for Laminex Wall Systems Adhesive Product information. Refer to Section 5:34 for Laminex Wall Systems Silicone Product information.

PRODUCT CHARACTERISTICS

Finishes:	(Finishes vary by colour/pattern) Glaze, Gloss, Tile, Ripple
Colours:	Refer to product brochure
Thickness:	2.7mm (Nominal)
Weight:	4.4kg/m ² approx.
Decorated:	One Sided (Double sided by special order enquiry)*
Core:	Black
Sheet Dimensions:	(Sheet sizes vary by décor) 1800mm x 900mm 2400mm x 900mm 2400mm x 1200mm 3000mm x 1200mm**
Warranty:	(Australia) 7 Year Limited Warranty

* Tile and Ripple not made double sided.
** Tile and Ripple only.

WHEN SPECIFYING

Material shall be Laminex Aquapanel as supplied by The Laminex Group. Colour or pattern shall be ... in Finish.

CARE AND CLEANING

Laminex Aquapanel is easy to clean. Clean the sheet surface with warm water and mild liquid detergent only. Do not use abrasive cleaners, waxes or polish on the surface.

SITE WORK NOTES

Storage and Transport

Sheets should be transported flat with minimum flex. Bulk stocks of Aquapanel should be stored flat on pallets and covered with a polythene type sheeting

to avoid dust penetration. Before installation store sheets upright on the longest edge and face to face on the decorated surface. Keep the work area clean. Lift sheets carefully. Do not slide on decorative surface or use as a work surface.

Preconditioning

Aquapanel should be unpacked and protective cover removed at the fitting site and allowed to stand for at least 48 hours prior to cutting and installing to allow the sheets to breathe and reach moisture equilibrium.

Preparation

Choose your starting point with the whole job in mind. Starting off with straight and plumb walls will help with whole job. Mark areas that need packing using a straight edge or square. Checking your levels and plumbs regularly will keep the job tidy and assist with installation. Check the Laminex Aquapanel for squareness in case re-sizing is needed. If using Laminex fixing system profiles check for fit and if necessary plane or sand the back edge of the laminate to ease the fitting. Laminex recommends that Aquapanel should be attached to a dressed timber frame with no more than 450mm between horizontal and vertical studs or battens.

PROPERTIES

Property	Unit	Measure	Standard
Application			VGS (Vertical General-Purpose Standard) [†]
Dimensional Tolerance	mm	+10/- 0mm	
Cone Calorimeter			AS/NZ 3837
BCA Group Number	Rating	3	
Average Specific Extinction Area	m ² /kg	134	
Resistance to surface wear [†]		Initial wear not less than 50 cycles. Average wear not less than 150 cycles.	AS/NZS 2924.1
Resistance to immersion in Boiling Water:		No deterioration other than slight loss of gloss. Gain in weight of not more than 4.0%	AS/NZS 2924.1
Resistance to dry heat at 180°C:		No deterioration other than slight loss of gloss &/or colour	AS/NZS 2924.1
Resistance to Steam:		No deterioration other than slight change of gloss and/or colour	AS/NZS 2924.1
Dimensional Stability:		Dimensional change of not more than 0.3% with grain and 0.65% across grain.	AS/NZS 2924.1
Resistance to impact by large diameter ball (324g)		No visible damage at a drop height of 100cm other than an indent of ≤ 10mm diameter	AS/NZS 2924.1
Resistance to Scratching		Min. 1 Newton force	AS/NZS 2924.1
Resistance to Staining:		Reagents groups 1 & 2 = no visible change, Reagents groups 3 & 4 = slight change of colour and/or gloss	AS/NZS 2924.1
Resistance to Colour Change in Artificial Light*:		Not more than slight colour change in Xenon arc light (minimum). Blue Wool: 6	AS/NZS 2924.1
Resistance to Cigarette Burns:		No deterioration other than moderate change in gloss and moderate brown staining	AS/NZS 2924.1
Resistance to Crazeing (Test 25):		No worse than hairline cracks across surface and/or edges, visible under x6 magnification	AS/NZS 2924.1
Resistance to Moisture at 65°C [#]		No worse than a slight change of gloss/colour, or hairline edge cracks or slight edge swelling after 2 days	AS/NZS 2924.1

[†] Additional relevant properties included.

* Laminex Aquapanel has good colour retention in normal interior applications.

However prolonged exposure to sunlight may cause some change in colour.

Laminex Aquapanel are therefore not recommended for exterior applications or interior applications with prolonged exposure to direct sunlight.

[#] Slight to moderate gloss change can occur in glossy laminate due to the high gloss level.

[‡] Not applicable to Ripple – low duty wear, average wear point of 10 cycles

Cutting and Drilling

Always cut sheets with the decorative surface face up. Cutting stroke should be down into the decorative surface. To cut use a fine tooth hand or power saw, (10 – 12 teeth per mm), masonry cutting disc, fine tooth band saw or fibro cement cutters. Note: Jig saws are not recommended but if using cut with an upward stroke and cut from back of

sheet). Clean all edges with a fine file, sand paper or plane to ensure there are no burrs or flattened edges. This will assist in inserting the sheet into fixing systems with minimum fuss. As with all woodworking, always ensure you wear the appropriate safety gear, including dust mask, eye protection and hearing protection.

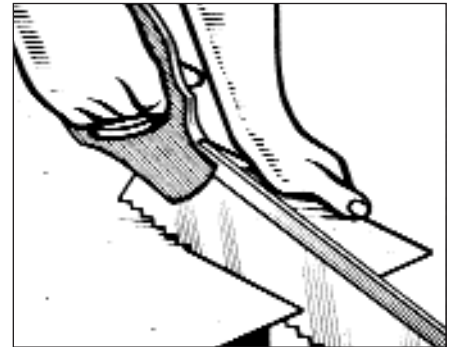

Drill holes into the sheet with high-speed twist drills. Use a hole saw for holes for edges larger than 18mm in diameter. Drill holes 2mm oversize to allow for expansion.

Fixing Systems

When using Laminex fixing systems, using the Laminex Mitre Box and Saw is recommended to assist in creating correct mitred angles on profiles. Place sticky tape over the section of profile or keep in protective cover when placing in the Mitre Box to keep the profile in good condition.

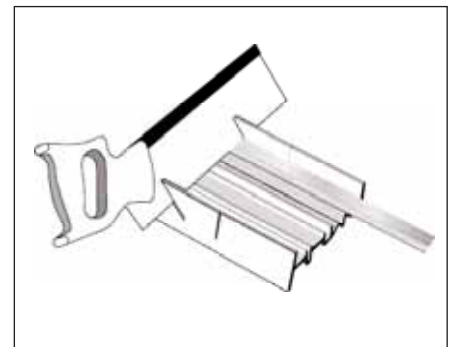

Preparing the Substrate and Installing

Ideally sheets should be attached to a dressed timber frame with no more than 450mm centers. You will need to install batons at 450mm intervals and at the sheet joins if there are not existing batons in place. Standard plasterboard can also be used in low humidity applications such as corridors. When adhering to plasterboard and cement sheet board in wet area, it must be moisture resistant.

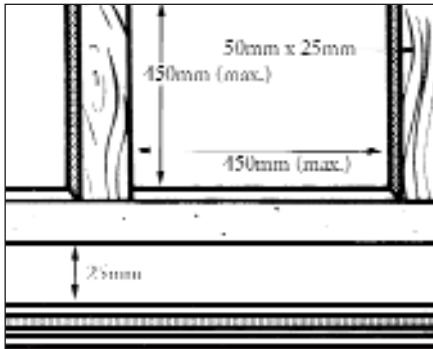

Measure your areas carefully. Then cut fixing systems and sheets one at a time as they are required.

To begin, install the fixing system profiles along the first edge. Internal corners require the use of an internal 90° profile so it is important to ensure the facing walls are square and plumb. Measure the height of the fixing profile required. Depending on the height of the walls of your room, the fixing profile may require a join. Mark and cut to required length. Keep in mind that if the fixing profile runs down to a shower base, you should not fix the profile below the top of the base. This will prevent water from seeping behind your wall.

Double check measurements and cut the internal corner profile to length and install using galvanised flat head nails. Ensure you punch in the heads of any nails. Now you're ready to install your first sheet.

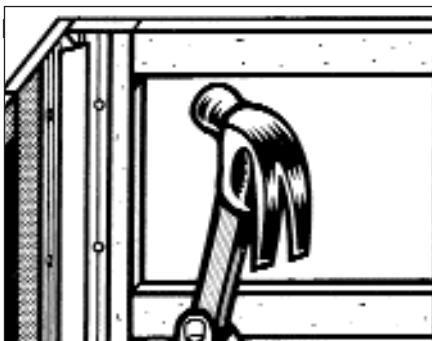

Measure the size of sheet and cut as required. If fixing around pipes or taps, you can drill straight through the sheet to create the hole size required. For larger cutouts begin by drilling small pilot holes.

If installing the capping profile along the top edge of the sheet, make sure to cut the internal joiner 7mm shorter than the sheet.

If installing a base profile along the bottom edge of the sheet, make sure to cut the internal joiner 3mm shorter than the sheet. Refer to mitre joints for more information.

Next, seal the joins by squeezing a bead of Laminex Wall System Silicone down the inside edge of the fixing profile.



Do not over fill expansion gap with silicone sealant as this will prevent natural movement of the sheet.

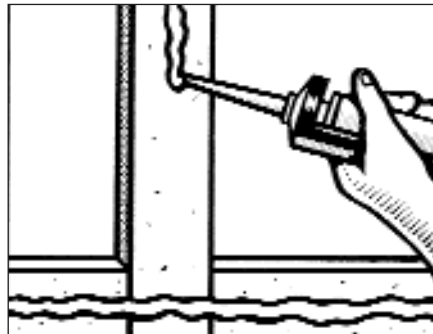

Apply a 5mm bead of Laminex Wall Systems Adhesive to the frame, where it will come into contact with the sheet.

Put the sheet that has been cut to size into place. Then, apply a little pressure against the sheet, so it comes into firm contact with the adhesive. Now gently remove the sheet and allow the adhesive to become tacky. This takes approximately five to fifteen minutes depending on climatic conditions.

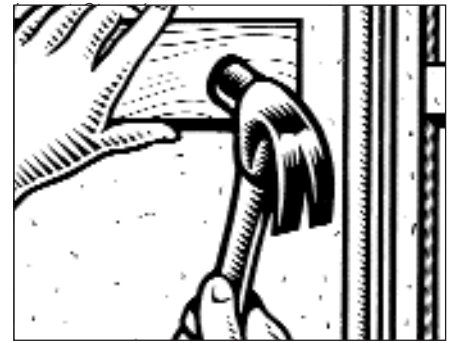

Place the sheet back into the fixing profile. You can put the next fixing profile into place while the first sheet is still slightly tacky.

Now firm the sheet with a tap to ease the sheet into its fixed and final position. DO NOT fix the sheet too tightly into the fixing system. They are specifically designed with a stop on the inside of the trim that allows for the sheet to expand or contract with changing room temperatures and humidity levels.

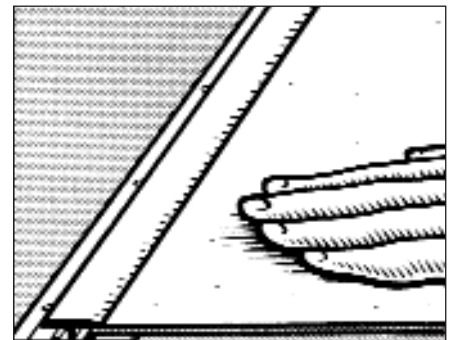

Divisional Profile

Divisional profiles are designed for walls that require two or more sheets to span the area. Make sure the previous sheet is installed square and plumb, then slide the Divisional profile onto the sheet edge, checking measurements once more. Allow for 7mm overlap if you are planning to install the capping profile or 3mm for base profile.

Once you are satisfied with the fit and alignment, remove the Divisional profile; apply a bead of Silicone down the inside edge of the profile. Then simply slide the profile back into place. Nail the Divisional profile in place.

HIGH PRESSURE LAMINATES

Fit the next sheet as before, ensuring that the appropriate method of adhering is followed.

External Corners

External corners are also required to be 90°. Carefully measure the sheet to ensure the fit into the previous profile is correctly aligned, then mark off the edge to be cut, taking care to ensure that the fixing profile is square and plumb with the edge of the wall and the sheet.

Once satisfied that the sheet is correctly aligned, mark the sheet and cut as before, ensuring that the edges are smooth and free from burrs or flattened ends.

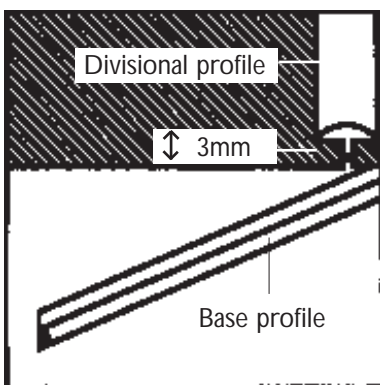
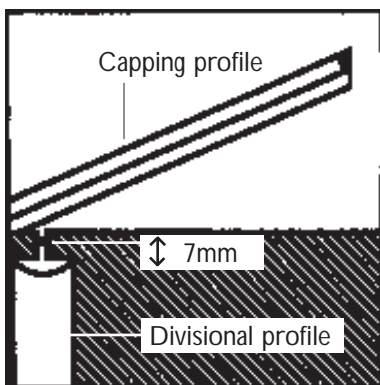

Check the fit in the external profile to ensure accurate fit with the wall and re-check your levels once more. Apply a bead of Silicone down the inside edge of the External profile and slide the profile onto the sheet, remembering to allow for the Capping or Base profile if required. Nail the External profile in place.

Capping and Base

Capping and base profiles complete the installation by finishing the top and bottom of the sheet neatly. Capping and base profiles are best installed as a continuous length across the sheets. You may need to run these around corners, depending on your job.

Firstly, starting from an internal or external corner, measure up the required length for installation. Simple divisional profiles can be run flush up to the Capping profile at 7mm from the top, or down to the Base profile at 3mm from the bottom.

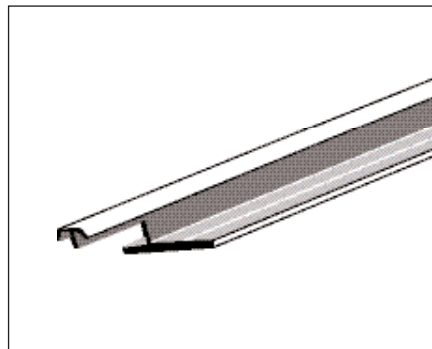

Corners are more detailed but are still easy. Measure the length required, and then, to allow for the joint, measure up a rebate to cut from the Capping end. Where a Capping profile joins with a vertical (divisional, external, internal) profile, you need to allow for overlap. Trim the back flange of the capping profile to accommodate the overlap.

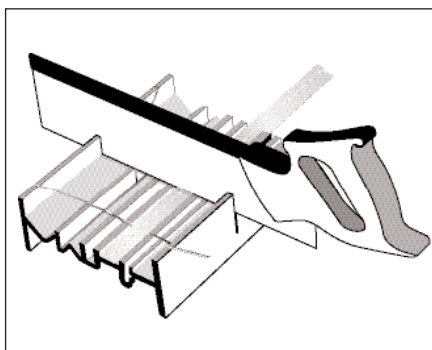

After you have located the rebate, check the fit once more.

Mitred Joints

If you need to cut mitred joints, we recommend you use the patented Laminex Mitre Box and Laminex Mitre Saw to help you cut 45° and 90° angles. The Mitre Box has a unique base specially designed to fit the Laminex Fixing System.

To cut 90° angles, insert the fixing profile into the Mitre Box. Using the Laminex Mitre Saw, make a straight cut through the profile. Always check your measurements.

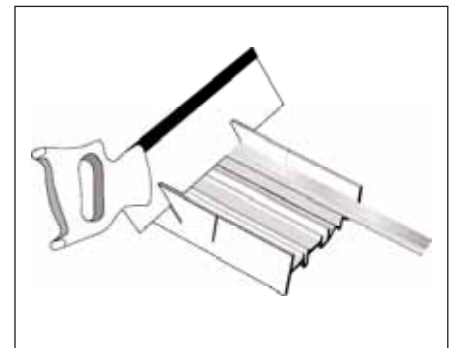

45° cuts can be made in both inward and outward faces. This allows for both internal and external corners, giving your job a professional finish.



Refer to the Fixing Systems Product information (pg 5.28).

Completing the Installation

Carefully seal all gaps around any exposed edges of the sheet with Laminex Wall Systems Silicone. Pay particular attention to wet areas such as shower bases and around any cut-outs in the sheets.

When inserting fixtures, make sure that the holes and cut-outs are slightly larger to allow for expansion. Always ensure that the holes are sealed with silicone to prevent moisture penetration.

If fitting a load bearing item such as a towel rail or shelving, fix through the sheet and into a wall stud or noggin. Make sure you apply Laminex Wall System Silicone to seal any penetrations.

SILICONE JOINS

If Laminex fixing profiles are not being used to join sheets, a simple butt joint can be used. The cutting and machining of each sheet (tile and patterns particularly) is critical to the overall appearance of the finished job. Apply bond breaker tape to the timber frame at the centre of the joint before fixing sheet to wall.

Always leave a minimum 3mm gap between the sheets. (Use an offcut of the sheet as a spacer). Sheets are then installed as previously detailed with a 5mm bead of adhesive applied to all studs in contact with the sheet.

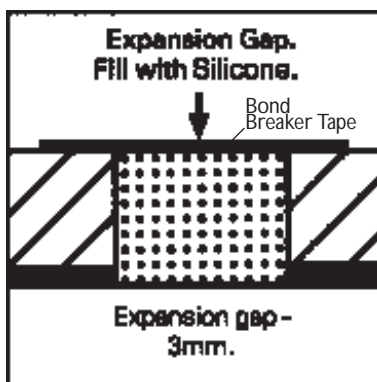

Run masking tape down the sides of each joint and apply Laminex Wall Systems Silicone to fill the expansion gap between the two sheets. Trowel off any surplus, remove masking tape and wipe off any excess silicone on the surfaces using a damp cloth or mineral turpentine.

Tooling

All sealant must be tooled into place. This action forces the sealant into the joint and assists the sealant to 'Wet Out'

the sides of the joint. The tooling action should positively force the sealant into the joint.

Note: The thickness of any solid material inserted between gaps must be added onto the recommended gap measurements.

Fill the gap with silicone, slightly overfilling.

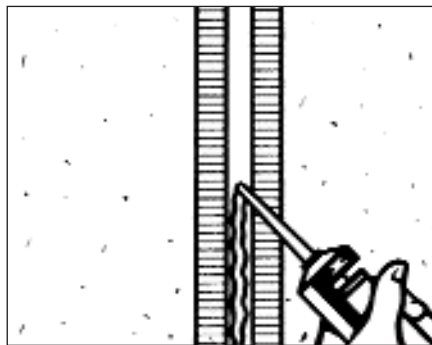

Use a wet spatula to trowel off the excess and remove the strips of tape.



Use a damp cloth or mineral turpentine to immediately remove any excess silicone from the sheet to prevent etching of the surface.

INSTALLATION ON PLASTERBOARD AND CEMENT SHEETS

Although not recommended, Aquapanel can be fitted to walls that are already lined with a flat sheet, such as plasterboard and cement sheeting. Refer to warranty for further information.

Standard plasterboard sheeting can only be used in low humidity applications, such as corridors. In areas of relative

humidity greater than 65%, standard plasterboard should not be used.

In wet areas, moisture resistant plasterboard or cement sheeting is required. Walls subject to possible dampness or high moisture pick-up should not have Aquapanel fixed direct, but installed to dressed timber frame or the wall surface must be waterproofed with an impermeable membrane.

Installation requires the following:

- All surfaces must be clean and free of grease, oil, dust and paint.
- Walls must be completely dry. If subject to possible dampness then a timber frame must be used, or the wall completely sealed.
- Walls must be flat and square. Aquapanel will not conform to an uneven surface.
- Clean surface with a solvent such as IPA (Isopropyl Alcohol) or white spirits using a two wipe method. (Apply the solvent with a clean cloth, then dry off with a second clean cloth before the solvent has flashed off).
- Use fixing system profiles in these applications.

Method of Application

As described for typical installations for profiles, except the sheet is bonded directly to the moisture resistant plasterboard or cement sheet using the following method:

- Run a 5mm bead of adhesive around the edge of the sheet.
- Use a zig zag pattern of 5mm bead of adhesive making sure that the bead is within 15 - 20mm of the edges of the sheet.
- Press the sheet against the wall to transfer the adhesive to the wall.
- Remove the sheet and hold away from the wall to allow adhesive to become tacky. This will take approximately 5 - 15 minutes depending on climatic conditions.
- Once tacky, press the sheet back against the wall and continue as before.

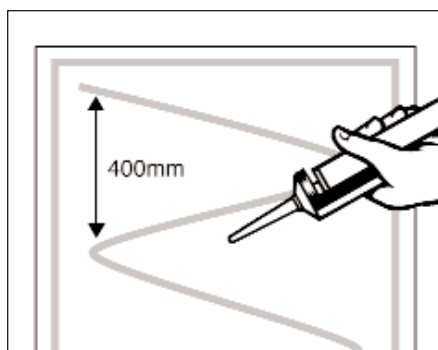

INSTALLATION ON BRICK AND CEMENT BLOCK WALLS

Although not recommended, Aquapanel can be fitted to brick, cement render and cement blockwork. Refer to the warranty for further information.

The wall must be dry and be impermeable to water. The wall must be sealed with suitable waterproofing membrane. It is essential that the wall is flat and free of protruding grout.

Sealing the Wall

Walls should be flat and free from loose particles. Coat the wall with an even layer of Trade Essentials Contact Adhesive or Laminex Wall Systems Adhesive with sufficient coverage to ensure a continuous film to provide an effective moisture barrier. Leave to completely dry for 24 hours.

Fixing to Wall

Refer to application instructions for adhering to plasterboard and cement sheets.

HELPFUL HINTS

- Check fit of profiles on Aquapanel sheets before starting a job. Plane or sand back edge of sheet if necessary.
- Directionally embossed designs may require retrimming for squareness depending on required installation tolerances.
- Ensure walls and corners are plumb, straight and square.
- Leave expansion gaps at all joins if butt joining and around cut-outs.
- Seal all joins and corners with Laminex Wall Systems Silicone.
- Clean off excess adhesive or silicone from the sheet surface immediately.
- Clean the sheet surface with warm water and mild liquid detergent only.
- DO NOT fit the sheet to wet or damp walls.
- DO NOT use mechanical fixing such as nails and screws without providing an expansion gap.
- DO NOT force the sheet into the fixing system past the small expansion lug.
- DO NOT fit the sheets tightly together.
- DO NOT use abrasive cleaners, waxes or polish on the sheet surface.
- DO NOT attempt to align embossed panels of opposing sheet orientation.

LAMINEX FIXING SYSTEM PROFILES



Base Profile



Divisional Profile

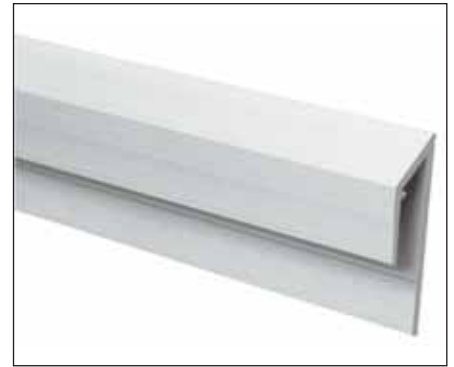

Capping Profile

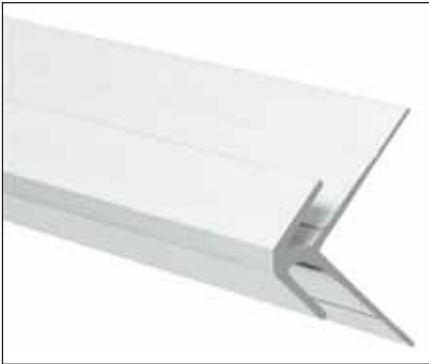

External Profile



Internal Profile

LAMINEX FIXING SYSTEMS

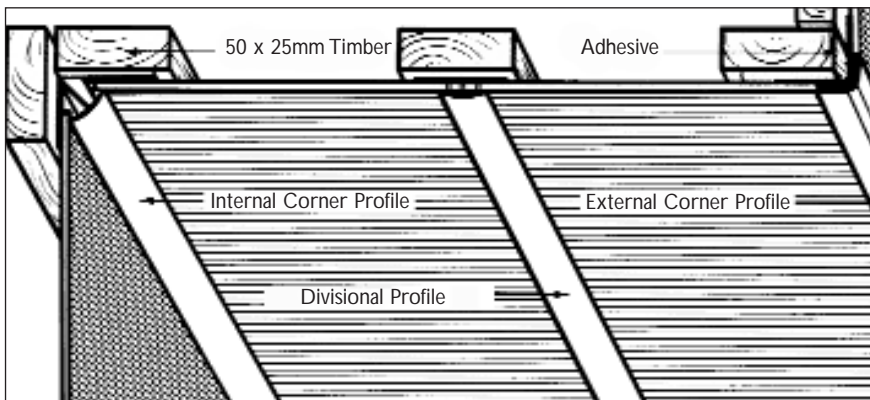

TYPICAL DETAIL - SHOWER

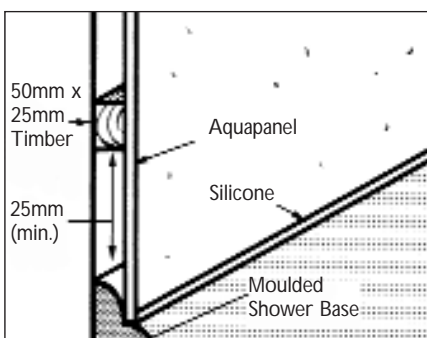

TYPICAL DETAIL - BATH

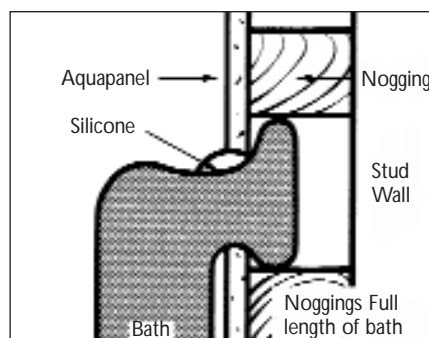

General Site Work Notes

Appendix 1. Handling & Product Application Guidelines
Section 9:1

Laminate Product: Care & Maintenance

Appendix 2. General Care and Maintenance
Section 9:2