

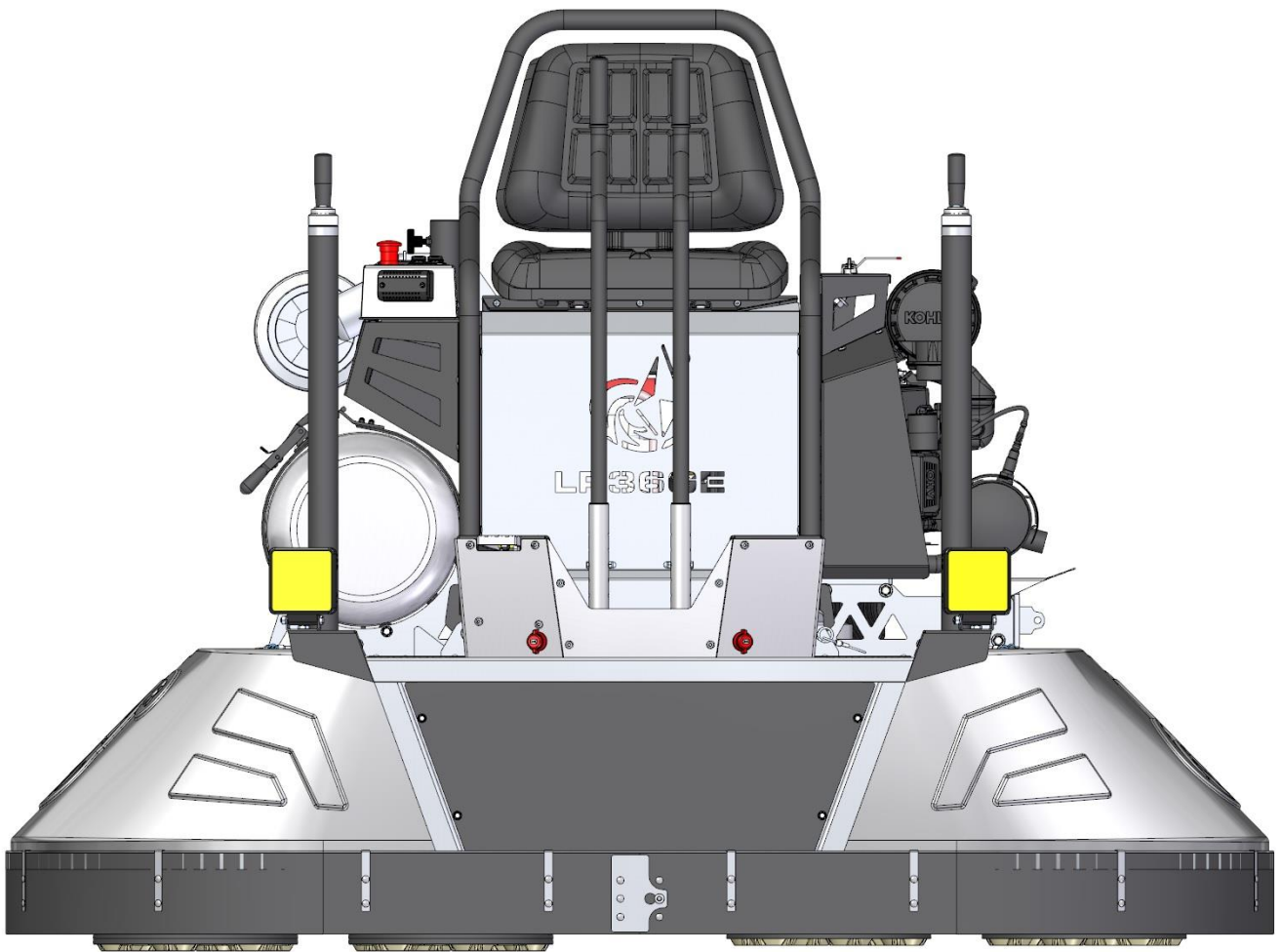

LAVINA® LP36GE USER MANUAL



Tech Support Line: 800-987-8403 | www.superabrasive.com | info@superabrasive.us



Warranty Registration Card

Complete and submit this form within 30 days from the date of purchase. The registration is invalid without the machine serial number.

Section 1: Customer Information

Customer name

Address

City

State and Zip Code

Phone #

Email

Section 2: Machine Information

LAVINA model

Serial #

Purchase Date

Purchased From (distributor, dealer)

*Email: warranty@superabrasive.us / Fax: 706-658-0357
Superabrasive Inc., 9411 Jackson Trail Rd, Hoschton, GA 30548*

Contents

1. WARRANTY AND RETURNS	5
1.1 WARRANTY POLICY FOR LAVINA® LP36GE	5
1.2 RETURN POLICY FOR LAVINA® TROWELS	6
2. GENERAL INFORMATION	7
2.1 MANUFACTURER	7
2.2 GENERAL DESCRIPTION.....	7
3. MAIN COMPONENTS AND CONTROLS.....	9
4. TECHNICAL DATA	11
5. SAFETY PRECAUTIONS	12
5.1 RECOMMENDED USE	12
5.2 PROHIBITED USE	12
5.3 GENERAL SAFETY	12
5.4 PREPARATION FOR WORK	12
5.4 STOP FUNCTIONS.....	12
5.5 SAFE USE	12
5.6 BEFORE YOU BEGIN	13
5.7 OPERATING THE TROWEL	13
5.8 AFTER WORK IS COMPLETED.....	13
5.9 THE WORK AREA.....	13
5.10 PERSONAL PROTECTIVE EQUIPMENT (PPE).....	13
5.11 OPERATOR	13
5.12 PROPANE SAFETY.....	14
5.13 FIRE SAFETY.....	14
5.14 LOCAL AGENCIES AND REGULATIONS	14
5.15 PROPANE CYLINDERS	15
5.15.1 REFUELLING CYLINDERS.....	15
5.15.2 STORAGE CYLINDERS	16
5.15.3 TRANSPORTING CYLINDERS	16
6. UNPACKING, HANDLING, TRANSPORTATION AND STORAGE.....	16
6.1 LIFTING THE MACHINE.....	17
6.2 TRANSPORTING THE MACHINE.....	18
7. OPERATING WITH THE TROWEL	19
7.1 STARTING THE ENGINE	19
7.2 STEERING	19
7.3 BLADE PICH	20

7.4 CONTROL BOARD	22
7.5 SEAT	23
7.6 ADJUSTING AND MOUNTING TOOLS	24
7.7 SA LPG CONTROLLER USER MANUAL	25
7.8 ELECTRONICS MODULE OF DIGITAL FUEL CONTROL SYSTEM	28
8. TOOLS AND ACCESSORIES	29
9. POPULAR TOOLS	30
10. MAINTENANCE AND INSPECTION	31
10.1 CHECK DAILY	31
10.2 CHECK AND REPLACE AFTER THE FIRST 8 WORKING HOURS	31
10.3 CHECK AND REPLACE EVERY 100 WORKING HOURS	32
10.4 RECOMMENDED OIL CHANGE INTERVALS	32
10.5 TROWEL MAINTENANCE SCHEDULE	33
10.6 TROWEL LUBRICATION	34
10.7 BELT MAINTENANCE	35
8.7.1 BELT INSPECT	35
10.7.2 REPLACEMENT OF THE DRIVE BELT	35
10.8 LAVINA® LP36GE ELECTRIC CIRCUIT DIAGRAM	38
11. TROUBLESHOOTING	39
12. DISPOSAL	39
13. MANUFACTURER'S CONTACTRS	39
14. EMMISION CONTROL WARRANTY STATEMENT	40

1. WARRANTY AND RETURNS

1.1 WARRANTY POLICY FOR LAVINA® LP36GE

If your warranty card is missing, contact your local distributor and request a warranty card, or visit us at www.superabrasive.com to download one. The customer is responsible for filling out the card and mailing it to the manufacturer's address as indicated on the card. To ensure registration and activation of warranty coverage, the warranty card must be mailed to the manufacturer within 30 days from date of purchase; failure to do so may void the warranty. Be sure to provide the manufacturer with all of the information requested, and most importantly with the distributor's name, machine serial number, and purchase date.

Superabrasive offers a guarantee on LAVINA® Trowels, covering manufacturing and material defects, for a period of 24 months from the date of purchase, as invoiced by Superabrasive. The following conditions pertain to this warranty:

- Applies only to the original owner and is not transferable.
- Trowel must not be dismantled and tampered with in any way.
- This warranty does not cover any failures or defects caused by normal wear and tear, accidental damage, damage during transport, improper handling, repairs conducted by an unauthorized facility (without prior authorization by Superabrasive), or operation that is not in compliance with the instructions provided in this manual. Superabrasive denies all responsibility for damages or injuries, to any persons or objects, caused by improper operation of the Trowel unit.
- This warranty will become invalid in the event that equipment or accessories used on/with the Trowel unit are not supplied or approved by Superabrasive.
- Covered components proven defective will be repaired or replaced at no charge.
- This warranty does not apply to any repair of/to of proprietary parts, nor does it cover cleaning or general maintenance.
- This warranty does not apply to items with aftermarket alterations, changes, or modifications.
- This warranty is limited to repair or replacement of covered components and reasonable labor expenses.
- In the event of a warranty claim, the Trowel unit must be returned to Superabrasive, or an authorized facility, for a warranty investigation, and subsequent warranty repair or replacement.
- All warranty returns must be shipped freight prepaid.
- This warranty is in lieu of and excludes every condition of warranty not herein expressly set out and all liability for any form of consequential loss or damage is hereby expressly excluded.

The above warranty conditions may be changed only by Superabrasive. Superabrasive reserves the right to inspect and make a final decision on any machine returned under this warranty. This warranty applies to new, used, and demo machines.

Superabrasive agrees to repair or replace, free of charge, any parts which have failed due to manufacturer or material defects. Repairs must only be performed at authorized service facilities that have been approved by Superabrasive. Shipping and handling fees associated with warranty claims must be pre-paid by the customer / claimant.

In the event that a warranty investigation determines that the damage or unit failure is not attributed to manufacturer or material defects, all costs associated with the repair of the Trowel will become the direct responsibility of the claimant. If payment is not rendered for such services, Superabrasive will assume ownership of the machine and any associated parts in possession.

Superabrasive does not authorize any person or representative to make any other warranty, or to assume for us any liability in connection with the sale and operation of our products.

The manufacturer is also not liable in the event that the customer fails to submit a Warranty Certificate, fails to follow manual instructions, uses non-original spare parts, or fails to service/clean the Trowel regularly and properly.

1.2 RETURN POLICY FOR LAVINA® TROWELS

LAVINA® trowels may be returned, subject to the following terms:

- Trowels may not be returned to Superabrasive Inc. for credit or repair without prior authorization. Please contact Superabrasive Inc. or your local distributor for authorization and issuance of a return authorization number. This number along with the serial number of the Trowel must be included on all packages and correspondences. Trowels returned without prior authorization will remain property of the sender and Superabrasive Inc. will not be responsible for these.
- No Trowels will be credited after 90 days from the date of Superabrasive's invoice.
- All returns must be shipped freight prepaid. All returns may be exchanged for other equipment or parts of equal dollar value. If Trowels are not exchanged, they are subject to a fifteen percent (15%) restocking fee.

2. GENERAL INFORMATION

This owner's manual is intended for the operator of the Lavina® LP36GE machine, the servicing technician as well as for anyone involved with operating or servicing the machine. We recommend that you read the instructions very carefully and follow them strictly. The manual includes information about assembling, using, handling, adjusting and maintaining your Lavina® LP36GE power trowel.

2.1 MANUFACTURER

Superabrasive was founded in 1987, as a manufacturer of high quality diamond tools for the stone and concrete industry. Today, Superabrasive is one of the world's leading companies in the production of diamond tools and floor grinding machinery. At Superabrasive, we strive to deliver the very best solutions to our customers, and enable them to work more efficiently.

2.2 GENERAL DESCRIPTION

Lavina® LP36GE ride-on power trowel is designed for the floating and finishing as well as grinding and polishing of concrete slabs.

Read all the safety instructions carefully. Safety instructions will be found throughout this manual. Keep all safety information in good, readable condition. Operators should be well trained on the operation and maintenance of the trowel.

Before using your trowel, test it on a flat, watered-down section of finished concrete. This trial test run will increase your confidence in using the trowel, and in the same time, it will familiarize you with the trowel's controls and indicators.

Take a notice of all the major components in point 3 like the engine, blades, air cleaner, fuel system, fuel shut-off valve, ignition switch, etc. Ensure engine and gearboxes lubricant levels are within proper operating range.

ENGINE

This trowel is equipped with KOHLER PCV740 engine with 24HP, V-twin big block, air cooled, who work with propane . Refer to the engine owner's manual for specific instructions regarding engine operation.

BLADES AND FLOATING PANS

The blades of the trowel finish the concrete as they are swirled by the surface. LP36GE is equipped with two vertical rotating shafts with with four each (6 inches wide) blades per rotor equally spaced in and attached to a the shafts by means of a spiders. In order to use tooling for polishing and grinding, two 36-inch floating pans are mounted on the blades. Each pan has four 13.2" Trowel Shine Tool Holders (metal plates with quick-change attachment). Each trowel shine holder can be equipped with all of Superabrasive's tools for grinding and polishing that use quick-change connection.

HELICAL GEARBOXES

LP36GE is designed with three separate helical gearboxes assemblies

STEERING

Dual control levers located in front of the operator's seat are provided for steering this trowel. Push the left control lever forward and pull the right control lever backward and the trowel will rotate clockwise on approximately a center axis. Pull the left control lever backward and push the right control lever forward and the trowel will rotate counterclockwise.

CONTINUOUSLY VARIABLE TRANSMISSION (CVT)

A Continuously Variable Transmission (CVT) has been installed to obtain maximum drive torque. This is accomplished by continually adjusting the drive ratio to obtain optimum torque and speed during all phases of finishing from low speed/high torque to high speed burnishing.

HOW IT WORKS

As the engine RPMs increase, the drive pulley closes, forcing the belt to ride outwards on the drive pulley. The closing of the drive pulley also forces the belt to open the driven or secondary pulley. The opening and closing of these pulleys creates a ratio variation—hence CVT or Continuously Variable Transmission.

WARNING!

The Lavina® LP36GE is manufactured and fitted for the above-mentioned applications only! Every other use may possess risks to the persons involved.

3. MAIN COMPONENTS AND CONTROLS

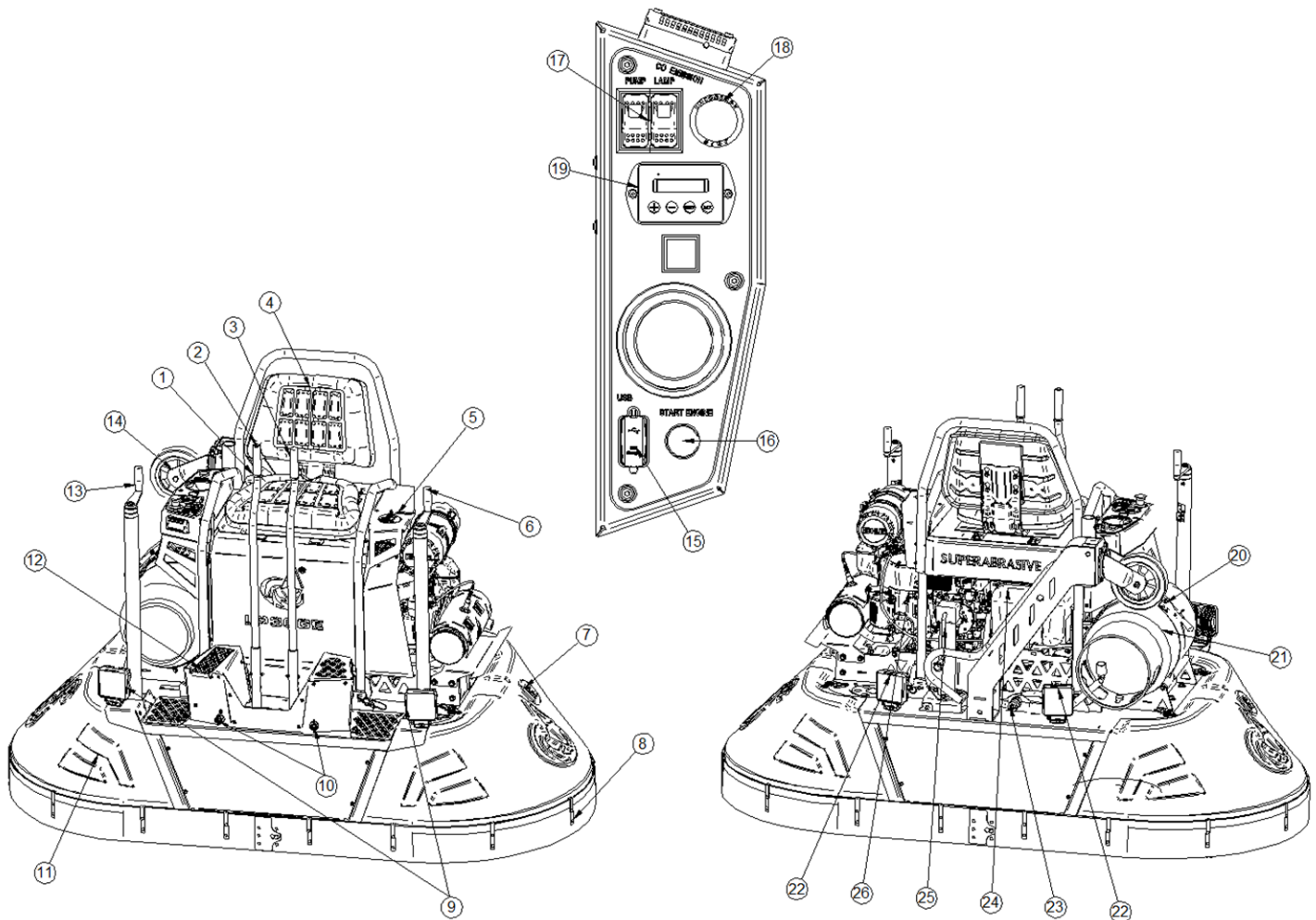

Figure 3

1. **Steerings control lever (Right side) – Allows the unit to move in either a forward, reverse, left or right direction;**
2. **Spray control button – When pressed, allows the fluid in the tank (24) to flow through the spray nozzles located in the front of the machine (10).**
3. **Steering control lever (Left side) – Allows the unit to move either a forward, reverse, left or right direction.**
4. **Seat – Provides a comfortable position for operation of the trowel. THE SEAT IS EQUIPPED WITH A SAFETY STOP SWITCH, WHICH SHUTS DOWN THE ENGINE WHEN THE OPERATOR IS NOT SEATED IN HER. Respectively the engine will not start unless the operator is seated.**
5. **Valve for adjust the water flow from external source designed to supply water directly on the tools.**
6. **Twin pitch control (Left side) – Adjust blade pitch for the left side of the trowel/ Turn the crank as marked on its top surface to increase or decrease blade angle of inclination.**
7. **Left trowel cover – Protects walls form slurry.**

8. **Heavy-duty shroud** – Protects walls from slurry.
9. **Front lights.**
10. **Nozzles** – Spray nozzles for the fluid from the tank (21).
11. **Right trowel cover** – Protects walls from slurry.
12. **Right foot pedal** – Controls blade speed. Slow blade speed is accomplished by slightly depressing the foot pedal. Maximum blade speed is accomplished by fully depressing the foot pedal.
13. **Twin pitch control (Right side)** – Adjust blade pitch for the left side of the trowel/ Turn the crank as marked on its top surface to increase or decrease blade angle of inclination.
14. **Hand wheel** – Used to transport the trowel.
15. **USB charger.**
16. **Start/Stop engine switch.**
17. **Pump and lights ON/OFF switches.**
18. **Emergency stop button.**
19. **Electronic module of digital fuel control system** - When running, it indicates the revolutions per minute of the motor. When not running, it indicates the worked hours. The hour meter will blink between 48-52 hours as a reminder for oil change.
20. **Strap** – hold the propane tank.
21. **Propane tank.**
22. **Back lights.**
23. **The water supply from external water source.**
24. **Water tank.**
25. **Manual jack** – lift the machine to its tires for transport.
26. **Engine.**

Label Data - The data on the label provides the correct kW, weight and dimensions; Weight (needed for transportation purposes); production year and serial number (needed for maintenance purposes).

Customer Service - For customer assistance and technical support call your local distributor or call Superabrasive Inc. at 1-800-987-8403 or visit us at www.superabrasive.com , where you can download a copy of this manual.

4. TECHNICAL DATA

Table 4.1

TECHNICAL DATA LAVINA® LP36GE	
Engine	KOHLER PCV740
Capacity of engine cc/cu.in	747/45.6
Power kW/hp	17/24
Rotor RPM	0-180 rpm
Engine RPM	1400-3600 rpm
Path Width mm/in	2045/80.5"
Pan diameter mm/in	2 x 915/36"
Tool Holders per Pan mm/in	4x335/13.2"
Blades per Rotor	4
Application	Wet and dry
Retardant tank capacity L/gal	20/5.2
Water feed	Front mist with pump and in the work area adjustable abundant amount.
Capacity Propane tank kg/lbs	15.2/33.5
Lifting with manual jack mm/in	200/7.9
Weight kg/lbs	646/1424
Machine LxWxH mm/in	2081/82x1041/41x1458/57.5
Packing crate LxWxH mm/in	2180/85.8x1140/44.9x1309/51.5

Table 4.2

NOISE AND VIBRATION EMISSIONS	
Guaranteed ISO 11201:2010 based sound pressure level at operator station in Db(A) ^a	92
Guaranteed ISO 3744:2010 based sound power level in dB(A) ^b	112
Whole body vibration per ISO 2631-1:1997 + A1:2010 in m/s ² Σ A(8)	0.15

a. With an uncertainty factor K of 2.5 dB (A) included per Note 1 in section 7.2.1 of EN 12649::2008+A1:2011

b. With an uncertainty factor K of 1.5 dB (A) included per Note 1 in section 7.2.1 of EN 12649::2008+A1:2011

5.SAFETY PRECAUTIONS

5.1 RECOMMENDED USE

The LAVINA® LP36GE Trowel is designed and manufactured for use with concrete, terrazzo and natural stone floors. This Trowel is rated for wet and dry use.

5.2 PROHIBITED USE

The Trowel MUST NOT be used:

- For applications different from those stated in this manual;
- In environments which (1) Possess the risk of explosion, (2) Possess high concentration of powders or oil substances in the air, (3) Possess the risk of fire, (4) Feature inclement conditions, (5) Possess electromagnetic radiation;

5.3 GENERAL SAFETY

- **NEVER** operate this equipment without proper protective clothing, shatterproof glasses, respiratory protection, hearing protection, steel-toed boots and other protective devices required by the job or city and state regulations.
- Avoid wearing jewelry or loose fitting clothes that may snag on the controls or moving parts as this can cause serious injury.
- **NEVER** operate this equipment when not feeling well due to fatigue, illness or when under medication.
- **NEVER** operate this equipment under the influence of drugs or alcohol.
- **ALWAYS** clear the work area of any debris, tools etc. that would constitute a hazard while equipment is in operation.
- No one other than operator is to be in the working area when the equipment is in operation.
- **DO NOT** use the equipment for any purpose other than its intended purposes or applications.

5.4 PREPARATION FOR WORK

Ensure that:

- You have secured the working area, so that no person unfamiliar with operating the Trowel can enter the area;
- The Trowel is not missing parts;
- The Trowel is in an upright, working position;
- All protection devices are working properly;

5.4 STOP FUNCTIONS

Functions for arresting of the machine include following:

- Start/Stop ignition switch;
- EMG stop button;

5.5 SAFE USE

The LAVINA® LP36GE is designed to eliminate all potential risks associated with its use. However, accidents may occur if unskilled or uninstructed workers fail to heed the list of potential risks below:

- Position Risks due to operator's incorrect working position;
- Tangling Risks due to wearing inappropriate working clothes;

- Training Risks due to lack of operational training;

NOTE: Machine operators should follow the instructions in the manual at all times.

RESIDUAL RISKS During normal operating and maintenance cycles, the operator is exposed to some.

5.6 BEFORE YOU BEGIN

- The working area must be clear from any debris or objects.
- A first-time operator must always read the manual and heed all safety instructions.
- Perform general daily inspections of the Trowel and inspect the Trowel before each use for any sign of damage.
- Inspect all safety devices.

5.7 OPERATING THE TROWEL

When operating the LAVINA® LP36GE, be sure that no one else is within close proximity to the Trowel.

5.8 AFTER WORK IS COMPLETED

When work is complete, clean the Trowel and its surroundings sufficiently.

5.9 THE WORK AREA

Ensure that the area is free of unauthorized people or vehicles, hoses, and always check the floor for debris.

5.10 PERSONAL PROTECTIVE EQUIPMENT (PPE)

When operating the machine, always wear safety shoes, ear protectors, safety gloves (especially when changing tools), and suitable clothing. All persons within the immediate working area must wear safety glasses with side shields.

5.11 OPERATOR

The operator must be aware of the Trowel's work environment, be properly trained prior to operating the equipment, and fully understand this manual. Only one operator may work with the machine at a single time. The operator must understand and interpret all the drawings and designs in manual, understand all sanitation and safety regulations pertaining to its operation, have floor grinding experience, know how to perform in an emergency situation, and have an adequate technical knowledge.

- The work environment for the Trowel should be clean, well-lit, and free of combustible elements.
- Do not Trowel any flammable materials or substances such as fuels, solvents, etc.
- Do not Trowel any corrosive substances unless the Trowel is specifically outfitted with containers suitable for this purpose.
- Do not Trowel any burning, smoldering, or hot materials. This could result in a possible explosion and/or damage to the Trowel components.
- If toxic or harmful substances accidentally enter the Trowel cleaner, the container and filters must be removed and cleaned immediately using the proper protective equipment and safety procedures.
- For this specific machine, sound tests indicate that the emitted noise is level is measured at a maximum of 91 decibels (dBA), for a distance of 1 meter from the machine (and height of 1.60 meters). The vibrations emitted from the machine have been measured at a maximum value of 0.03 m/s². • CAUTION: The National Institute for Occupational Safety and Health (NIOSH) recommends that exposure to noise in the working environment be maintained below a level equivalent to 85 dBA for a period of eight hours, in order to minimize occupational, noise induced hearing loss. Any persons working in proximity of the Trowel should wear the proper hearing protection in order to prevent hearing loss. Please refer to your local laws and regulations for further information on the matter.

- Store the Trowel in temperatures between 32°F and 104°F (0°C and 40°C). Cover the Trowel in order to protect it from accumulating debris and/ or environmental elements.

5.12 PROPANE SAFETY

Propane is a flammable gas whose vapors are heavier than air. As is the case with gasoline, propane can explode if the proper cautions are not heeded. Propane is odorized with an agent having a distinct odor that is recognizable at very low concentrations. This helps in identifying leaks, even when they are small.

- Awareness and basic safety precautions are required when working with propane. As long as these precautions are followed, risk is negligible. Ignorance, however, could pose needless risk.
- The two greatest hazards with propane powered floor care machines are:
 - **Carbon Monoxide Poisoning:** This is the most frequently reported incident associated with propane powered floor care machines and is caused by excessive exhaust emissions. The symptoms are headache, dizziness and nausea. A major cause involves engines with poor preventive maintenance practices, usually those with dirty air filters and machines operated in confined areas without adequate ventilation. Another cause may be substandard, inexpensive machines with no emissions control technology and improperly set carburetion.
 - **Overfilled Fuel Cylinders:** Nearly all fire-related incidents reported result from bringing a cylinder into a building without first checking for overfill. This action is dangerous, unwise, and unnecessary.

5.13 FIRE SAFETY

- Be aware of the potential dangers of fire or explosion when using propane, and take normal fire-safety precautions.

Fire: There is a possibility of fire from LPG vapor leaking or venting from fuel cylinders or carburetion

SAFETY PRECAUTIONS, Continued equipment.

Explosion: LPG vapor concentrated or confined to a small, restricted space may explode or ignite.

Propane may experience a **BLEVE**, a boiling liquid expanding vapor explosion.

Emissions: All propane-powered floor care machines produce emissions. Most are harmless, but some are dangerous and can be fatal. Carbon monoxide (CO) poses the greatest risk, since CO can be lethal within as little as 30 minutes exposure at a concentration of 3, 000 parts per million (ppm) concentration.

5.14 LOCAL AGENCIES AND REGULATIONS

• NFPA

Operating a propane powered floor care machine requires compliance with certain safety regulations. The National Fire Protection Agency (NFPA) Standard for Storage and Handling of LP Gas is the appropriate authority for safe propane use. A copy of this publication is available through the NFPA in Quincy, MA (1-800-334-3555).

Among its regulations, NFPA #58 requires that all personnel

employed in the handling of propane gas be trained in its proper handling and operating procedures. It also requires them to carry a written certification from their employer or training supervisor to attest to such training. Although this is directed mainly to those who fill and transport liquid propane gas, Onyx Environmental Solutions recommends that operators of propane powered floor care machines in public places be trained and certified as well.

With regard to operation of propane powered floor care equipment, even though NFPA #58 8-4.5 says "these machines shall be permitted to be used in buildings frequented by the public, including the times when such buildings are occupied by the public," Onyx Environmental Solutions suggests usage when occupancy of a given work area is minimal.

• CARB / EPA

The California Air Resource Board (CARB) and Environmental Protection Agency (EPA) also set limits for propane powered engines used outdoors, but CARB/EPA approval does not signify that the engine is safe to use indoors.

• CGA

The Canadian Gas Association (CGA) has set a limit of 1500 ppm CO in exhaust flow.

- **OSHA**

For propane powered machines used indoors, the Occupational Health and Safety Administration (OSHA) has established a limit of 50 ppm CO for 8 hour time weighted average (TWA) in ambient air and is considering a limit of 800 ppm CO in exhaust flow.

- **DOT**

The Department of Transportation (DOT) has established regulations regarding the safety of fuel cylinders including the ones used on propane powered floor care machines.

- **Local Agencies**

Local law enforcement agencies such as the local Fire Marshall also rely on independent testing labs such as UL and CGA before giving their approval of the use of some equipment. These labs thoroughly test equipment and submit their stamp of approval only after rigorous testing. While not being required by all law enforcement agencies, the stamp of approval by these agencies further assures the operator that he or she is working with and around safe equipment.

NOTE: In order to reduce all consequences of the above mentioned risks, we advise that machine operators will follow the instructions in the manual at all times.

5.15 PROPANE CYLINDERS

- The Propane cylinders are constructed of either aluminum or steel. We recommend aluminum because it is lighter and guards against rusting. The cylinder used on propane powered trowels is classified as a 4E240 cylinder. Its rated capacity is 33.5 lbs. and this designation refers to the model of the cylinder. Actual propane capacity achieved during filling can be less than, equal to, or slightly more than 33.5 lbs. Use only UL, CTC/DOT listed cylinders.
- The propane cylinder used on the machine is a motor fuel cylinder as listed by the Department of Transportation. Unlike the common 33.5-lbc propane outdoor grill cylinders (which are not legal for use on propane floor machines), the motor fuel cylinder has a number of safety systems designed into it to ensure your safety at all times.
- There are two types of 33.5 lb. motor fuel cylinders.

Liquid draw

Vapor draw

- The liquid draw cylinder is used on larger vehicles like forklifts. These machines have special vaporizing carburetors to allow the propane to change from a liquid to a gas before being burned in the combustion chamber.
- The vapor draw cylinder is used on small machines like the propane powered floor care machines. The Trowel generated by the engine draws up the Propane gas vapor through the fuel system. The propane powered floor care machine does not have an evaporating system and will freeze up if liquid propane is introduced to it. It is necessary that special attention be paid to ensure that neither the liquid nor the vapor draw cylinders be overfilled.

5.15.1 REFUELLING CYLINDERS

- The proper filling of propane cylinders is a subject so important that it warrants special attention. Propane cylinders should only be filled by qualified propane dealers.
- Most important, propane cylinders should be filled no more than 80% of their rated capacity. The other 20%, which is about 4" (10 cm) from the top of the cylinder, is called the vapor space or headspace. This vapor can be compressed without causing the pressure relief valve to open and vent gas to the area around the cylinder. If there is no headspace to allow for fuel expansion, the pressure relief valve will open, releasing propane gas into the atmosphere. This is a very dangerous and volatile situation as there is always the possibility that enough of the vented

gas could find its way down to the floor and come in contact with a pilot light from a furnace, hot water heater, or other source of ignition.

Propane changes into a gas, is -44°F (-42° C). Exposing unprotected skin to propane gas or liquid could result in frostbite injury.

All new cylinders should be vented and purged of air per manufacturer's instructions before use. Never bleed propane cylinders indoors.

5.15.2 STORAGE CYLINDERS

- When not in use, propane cylinders always should be stored outside in an upright position in a secure, tamperproof, steel mesh storage cabinet. This cabinet may be located next to the building but with at least five feet (1.5 m) of space between the cabinet and the nearest building opening (door or window), also away from heat and direct sunlight.
- Do not install the cabinet near a stairway or street elevator as vented propane gas will seek a lower level since it is heavier than air and could find its way into the basement of the building. Do not store cylinders full or empty inside a building or inside a vehicle. Although it is unlikely that propane will vent from a stored cylinder, if it should, the vapor could come in contact with an ignition source such as a spark from a power tool or other appliance and create a flash fire.
- Do not smoke or use a device with an open flame when handling or transporting propane cylinders.

5.15.3 TRANSPORTING CYLINDERS

- When transporting cylinders to a propane dealer or to a job, make sure the cylinders are securely fastened and standing in an upright position with the service valve closed.
- A cylinder rattling around in the back of a vehicle and banging into other objects constitutes a hazard. Avoid dropping or banging cylinders against sharp objects.
- The propane cylinders are sturdily constructed but a series of hard jolts could cause damage.
- Please note that any cylinder that has been filled is always considered full, no matter how little propane gas remains in it. This is because even when all liquid has evaporated into vapor there is still some propane gas vapor left in the cylinder. Because this remaining fuel is flammable, an empty cylinder should be treated with the same careful procedures as one that is filled to the 80% level with liquid propane. The only time that a cylinder is considered empty is when it is new, before it has been filled with propane.
- When transporting a propane powered floor machine, the propane cylinder may be strapped onto the machine as long as the machine itself is firmly secured in the vehicle.
- Of course, spare cylinders should always be secured in an upright position.

6. UNPACKING, HANDLING, TRANSPORTATION AND STORAGE

When unpacking the machine, please check that the following accessories are included:

- **Heavy-duty shroud (see fig.3);**
- **Hand wheel that is used for transportation (see fig.3);**

If any of the above-mentioned parts are missing, please contact your local distributor or our sales representative.
Protect the environment: Please dispose of packaging materials and used machine components in an environmentally safe way according to local disposal regulations.

Attention

- During transportation, battery and propane tank must be securely fastened and completely disconnected at all times.

- Before operating the Trowel after transportation, propane tank and battery must be re-connected and correctly assembled:

- Battery: Make sure that the wires are firmly connected to the correct terminals (black (-) & Red (+)). Also confirm that the bracket that holds the battery in place is correctly assembled, so that the battery can't move during operation.

- Propane tank: Make sure that the tank is firmly held in place by the lock and holder plate where the propane tank sits on the back of the machine. It should not be able to move when its correctly assembled.

When handling and transporting the machine, never use the handles or other machine parts to lift the machine. Use always a skid or pallet for transportation, and never transport an unprotected machine in the rain or snow. Always store and transport the machine in an upright position. The machine should also always be stored in a dry, frost-proof environment.

6.1 LIFTING THE MACHINE

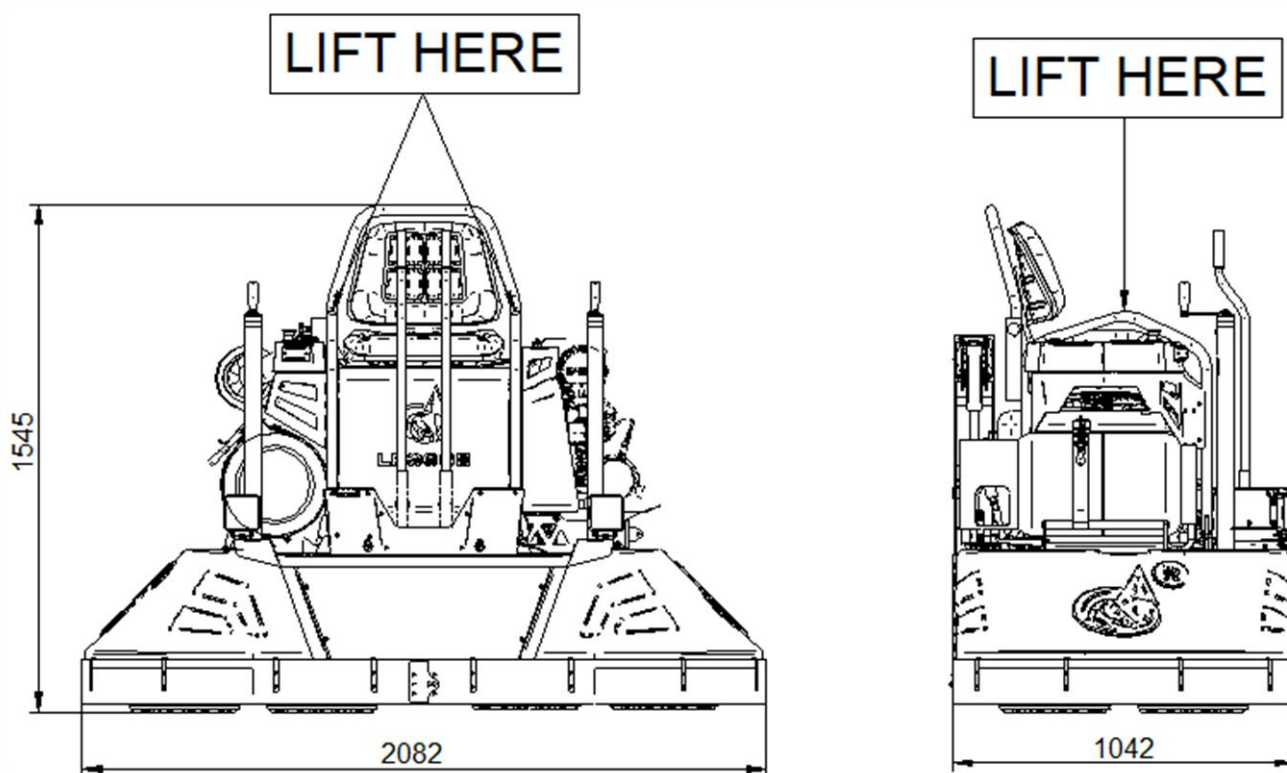

Figure 6.1

IMPORTANT:

TO LIFT THE MACHINE USE ONLY THE SPECIFIED PLACES AT FIG. 6.1.

6.2 TRANSPORTING THE MACHINE

Lavina® LP36GE has a third wheel for easier transportation. It has two positions: in working position and in transport position and is locked with a pin. To move the machine into transport or tool change position first remove the third wheel from the working position, turn the handle of the jack to raise the left side of the machine. When you reach a position where it is possible to place the third wheel in transport position, install it on the frame and insert the pin. Continue turning the handle all the way, which will raise the right side of the machine and bring the machine to a horizontal position.

To turn the machine into working condition, we perform the same actions but in reverse order.

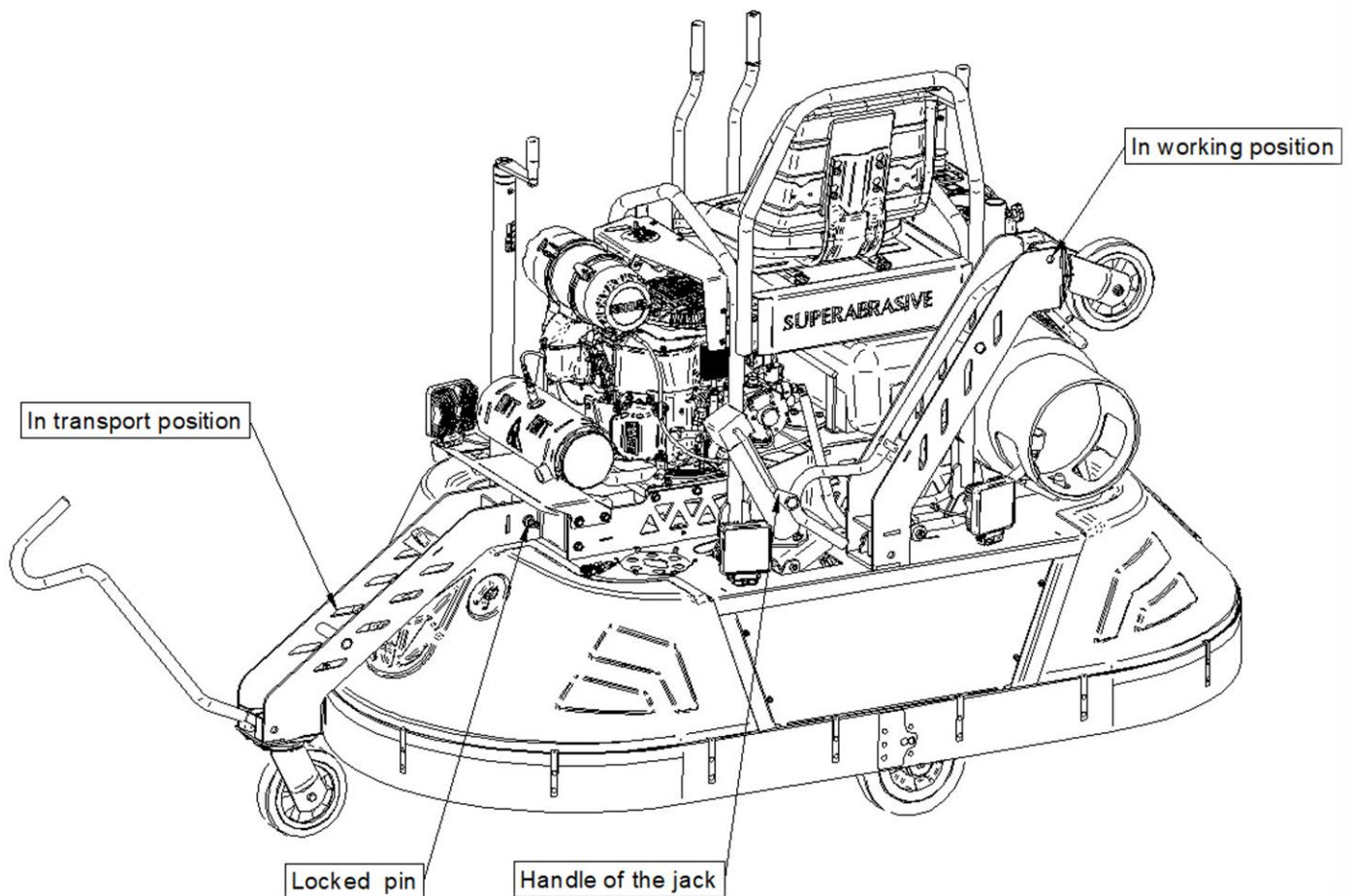

Figure 6.2

7. OPERATING WITH THE TROWEL

7.1 STARTING THE ENGINE

- Place foot on the trowel's platform, grab on to the frame, lift yourself onto the trowel, and sit down in the operator's seat.
NOTICE: The trowel is equipped with a safety stop switch that will not allow the engine to start unless an operator is sitting in the operator's seat. The weight of the operator depress an electrical switch, which allows the engine to start.
WARNING! – NEVER disable or disconnect the safety stop switch. It is provided for the operator's safety, and injury may result if it is disabled, disconnected, or improperly maintained.
NOTICE: Using the safety stop switch to stop the engine after every use will verify that the switch is working properly. Remember to turn the key to OFF position after stopping the machine. Not doing so may drain the battery.
- The right foot pedal controls blade and engine speed. The position of the foot pedal determines the blade speed. Slow blade speed is obtained by slightly depressing the pedal. Maximum blade speed is obtained by fully depressing the pedal.
- Keeping your foot OFF the right foot pedal, turn the ignition key fully clockwise and listen for the engine to start. Once the engine has started, release the ignition key. The throttle speed defaults to idle. Let the engine warm for a few minutes.

7.2 STEERING

Two control levers located in the front of the operator's seat provide directional control for the trowel (fig. 7.2). Table 7.2 illustrates the various directional positions of the control levers and their effect on the ride-on trowel.

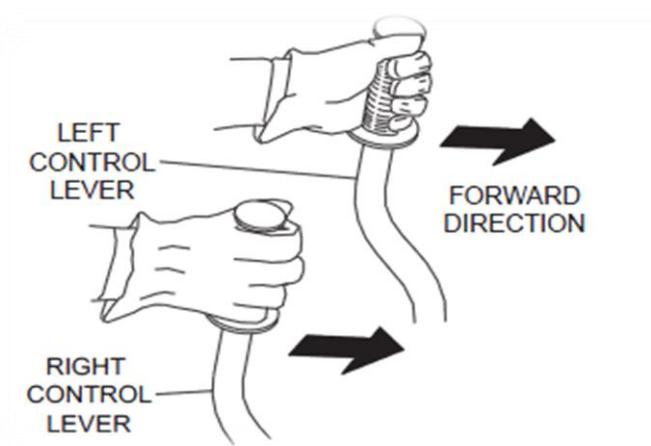

Figure 7.2

Table 7.2

CONTROL LEVER DIRECTIONAL POSITIONING		
Control lever	Direction	Results
Left	Move control lever forward	Causes the ride-on trowel to move forward and to the right.
Left	Move control lever backward	Causes the ride-on trowel to move backward and to the left.
Right	Move control lever forward	Causes the ride-on trowel to move forward and to the left.
Right	Move control lever backward	Causes the ride-on trowel to move backward and to the right.
Left and Right	Move both control levers forward	Causes the ride-on trowel to move forward in straight line.
Left and Right	Move both control levers backward	Causes the ride-on trowel to move backward in straight line.
Left and Right	Move both control levers to the right	Causes the ride-on trowel to move to the right.
Left and Right	Move both control levers to the left	Causes the ride-on trowel to move to the left.

- Push both the left and the right control levers forward (see fig. 7.2).
- With your right foot, quickly depress the right foot pedal halfway. Notice that the ride-on power trowel begins to move in a forward direction. Return both control levers to their neutral position to stop forward movement, and then remove your right foot from the right foot pedal.
- Practice holding the machine in one place as you increase blade speed. When about 75% of maximum blade speed has been reached, the blade will be moving at proper finishing speed. The machine may be difficult to keep in one place. Trying to keep the ride-on trowel stationary is good practice for the operator.
- Practice maneuvering the ride-on trowel using the information listed in Table 7.2. Try to practice controlled motions as if you were finishing a slab of concrete. Practice edging and covering a large area.
- Try adjusting the pitch of the blades. This can be done with the ride-on trowel stopped or while the trowel is moving, whichever feels comfortable. Test the operation of optional equipment like retardant spray and lights.
- Push both the left and right control levers backward and repeat steps 3 through 6 while substituting the word *reverse* for *forward*.

NOTICE: Trowel arms can be damaged by rough handling or by striking exposed plumbing or forms while in operation. **ALWAYS** look out for objects which might cause damage to the trowel arms.

7.3 BLADE PICH

Sometimes it may be necessary to match blade pitch between the two sets of blades. There are some signs that this may be necessary. For example, the differences in pitch could cause a noticeable difference in finish quality between the two sets of blades or, the difference in blade pitch could make the machine difficult to control. This is due to the surface area in contact with the concrete—the blade set with the greater contact area tends to stick to the concrete more.

To change the blade pitch just rotate the levers (fig. 7.3.1). Make sure that you make the same correction at both levers so the blade pitch is equal on both heads. At figure 7.3.2 is shown suggested working pitch according to different conditions of the concrete.

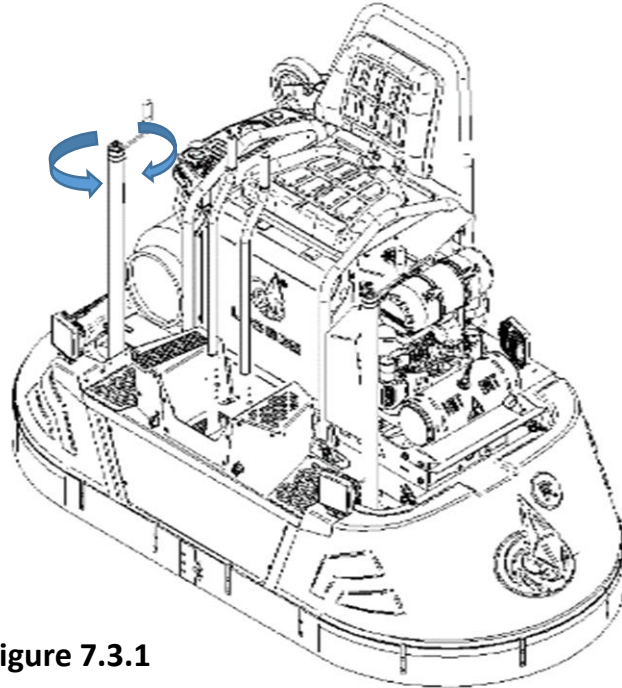

Figure 7.3.1

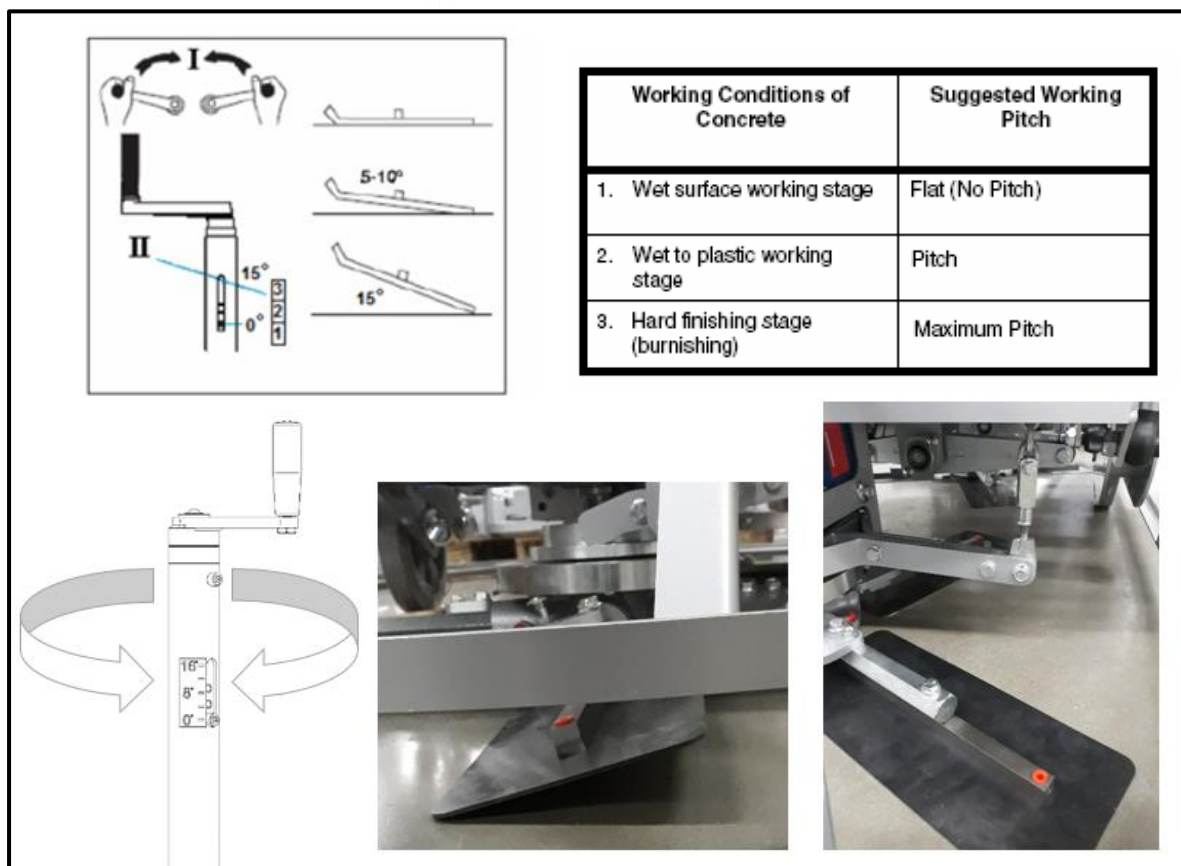

Figure 7.3.2

- When changing or setting the pitch (angle) of the trowel blades, slow the machine, set the desired pitch on the left side of the machine, then adjust the right side to match.
- To increase the pitch, turn the pitch control inward (I). Use the pitch indicator (II) to adjust pitch equally on both right and left trowel blades.

7.4 CONTROL BOARD



Figure 7.4

1 CO Shut-off Module – KEEP IT DRY ALL TIMES!

Normal Operating Temperature: -40°F (-40°C) to 158°F (70°C)

Activation Levels (Relay Normally Open)

35 ppm TWA for 1 hour = Yellow LED flashing

>200 ppm for 5 minutes = Red LED flashing and relay activation

>400 ppm for 35 seconds = Red & Yellow LED flashing and relay activation

If the 35 ppm level is triggered it will flash the yellow LED. If either of the higher levels are reached the pattern will switch over.

All activation levels will clear when the average ppm < 35 ppm

Low battery or Sensor self-diagnostics will trigger an EOL signal.

EOL Signal = Yellow LED flashing and buzzer chirp every 60 seconds.

2 Pump ON/OFF switches

3 Emergency button used to stop the motor in case of emergency

4 Lights ON/OFF switch

5 Electronics Module of digital fuel control system. Indicates the revolutions per minute of the engine, the worked hours, the hour meters and reminders for checks.

6 QR code. When you scan it with your phone, it will redirect your browser to Lavina manuals page.

7 Cup holder

8 USB charger

9 Start/Stop Engine switch. Turn key fully to the right (make contact) to ignite the engine. Fully to the left will arrest the engine.

7.5 SEAT

The seat allows back and forth position adjustment to provide a comfortable position for the operation of the trowel. The seat is equipped with a safety stop switch, which shuts down the engine when the operator is not sitting on the seat. Respectively the engine will not start unless the operator is seated figure 7.3.1.



Figure 7.3.1

The seat has the ability to be rotated forward to the steering levers, which opens up an area for viewing the engine and filling the water tank figure 7.3.2.



Figure 7.3.2

The frame with the seat allows for right-hand rotation to provide sufficient space for servicing the engine compartment. First the propane tank must be removed from the machine, then both pins on the left side of the frame and the rotation can be done (figure 7.3.3 and figure 7.3.4).

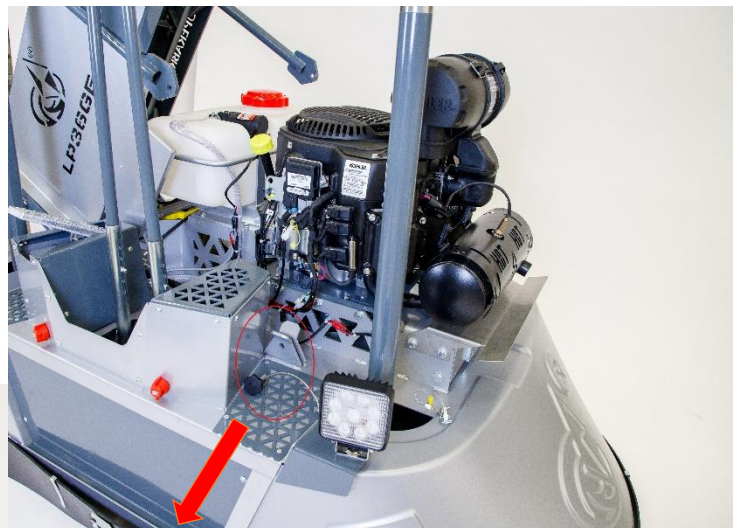

Figure 7.3.3



Figure 7.3.4

7.6 ADJUSTING AND MOUNTING TOOLS

Lavina® LP36GE has 8pcs of 13.2" tool holders (A95.00.00) for power trowel, four mounted on each of the two pans (fig 7.6.1) . Each of these holders rotates around its own axis in order to provide even wearing of the tools.

The holders are for tools with the Quickchange connection. To change the tools you need first to unlock the butterfly using the key we provide you remove the security plate then load the tools you want and insert the security plate again so the tools cannot go backwards, rotate and lock the butterfly .

When using the Rings tools for polishing. There tools are mounted directly on the **Quickchange** plate of the holders locked with **Security plate for RING TOOLS**.

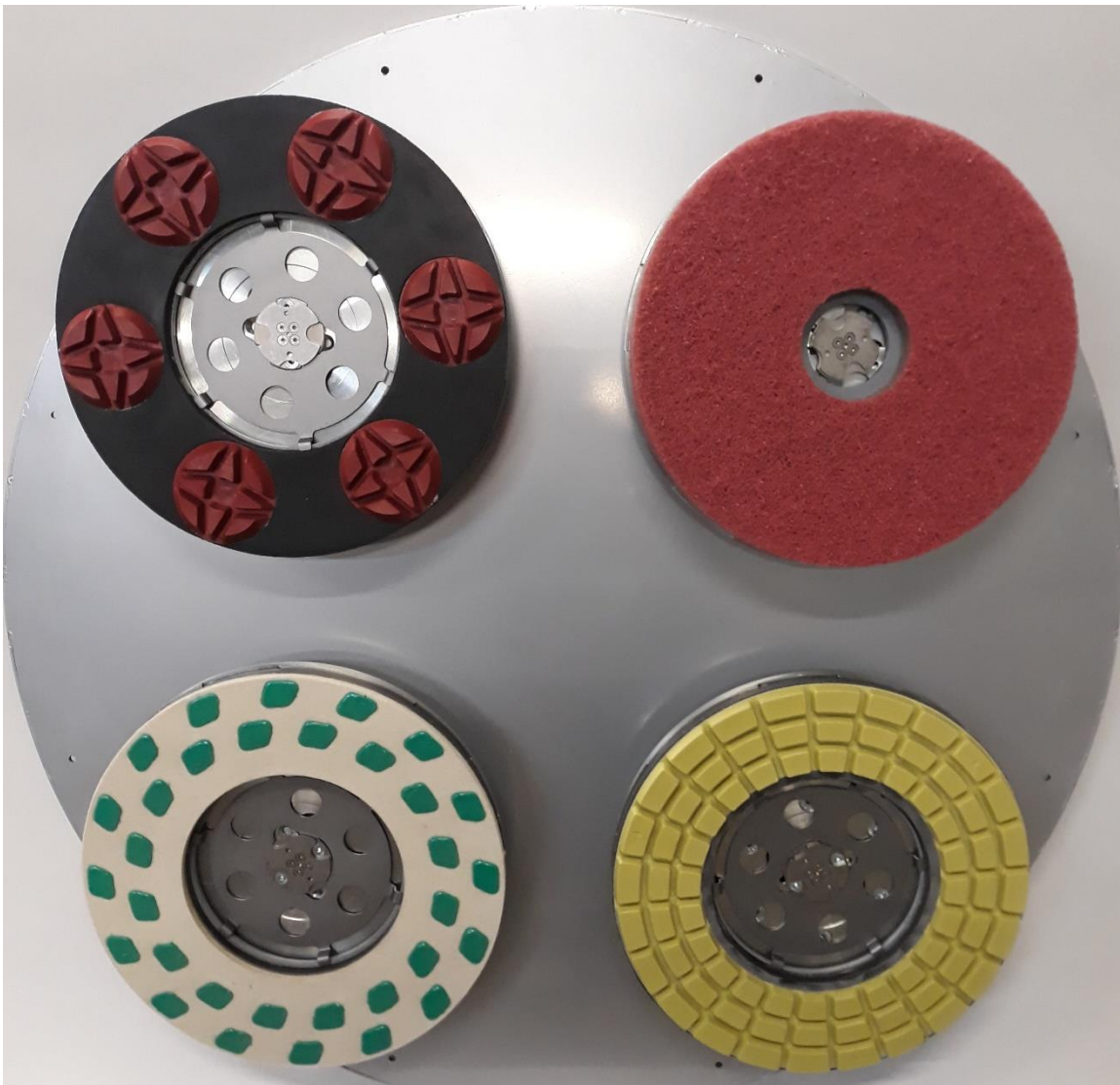

Figure 7.6.1

WARNING: Always secure the Quick Change tools with the butterfly, lock with the tool holder key and make sure that the butterfly is securely locked and it holds the security plate not to fall off.

7.7 SA LPG CONTROLLER USER MANUAL

The SA LPG Controller is a high-performance, digital fuel control system featuring closed loop feedback, fuel lock-off capability, emissions safety warnings with shutdown, and an LCD screen for user interface. The system is highly responsive to changes in engine load, providing optimum the air-to-fuel ratio regardless of operating conditions.

System Components

The following parts are included with the system

- Electronics Module
- Integrated Wire Harness
- Fuel Control Valve
- Fuel Control Housing
- O2 Sensor
- LPG Regulator with lock-off

Individual items are available as replacement parts if necessary

Overview of Features

Closed Loop Fuel Management System

The SA LPG Controller uses closed-loop feedback from the O2 sensor to control the amount of fuel introduced to the engine via the Fuel Control Valve. This technology continuously monitors engine emissions and is capable of making fuel corrections to compensate for varying engine loads and conditions.

Faulty O2 Sensor Detection

If a faulty O2 sensor is detected, the SA LPG Controller will alert the user within 3-5 minutes from a cold-start. A message will be displayed on the LCD screen to let the user know that the O2 sensor needs to be replaced.

Emissions Warnings and Shutdown

If the SA LPG Controller detects Carbon monoxide emissions, it will shut the engine down via the kill-switch. For LED color coding, read the CO shut-off module specification, page 19.

Dual Hour Meters

The SA LPG Controller has two hour meters, one for the engine and the other for the equipment. The Engine Hours are resettable, which should only be done if the engine is replaced. The Equipment Hours is non-resettable and shows the total hours on the equipment, similar to the odometer of a vehicle.

Battery Voltmeter

This feature allows for real-time display of the battery's voltage, which also helps for troubleshooting any battery or charging system issues that may arise.

Engine Tachometer

Displays the current engine speed (in RPM). This should be used to assess proper idle, WOT and engine speed for the appropriate tooling.

Job Timer

The job timer feature works when the engine is running with equipment, and will not continue to run if the engine is stopped. The job timer allows for easy timing of jobs or work areas to help determine speed. Resetting the job timer is password protected.

Service Alerts

The SA LPG Controller provides equipment-specific service alerts for the following items:

- Air Filter
- Oil Change + Filter
- Spark Plugs
- Belt Inspections
- Tooling Inspections

Each item has individual alerts at different hour intervals, and the SA LPG Controller will start alerting the user when the hour interval is over. To reset a particular service alert, simply press the Enter button. The interval starts to blink. Then press and hold the “+” and the Enter buttons for a couple of seconds. The interval should be reset.

Main Menu Navigation and Use

This section outlines how to navigate the menu and interact with certain features.

Main Menu

The Main Menu contains the following screens, which can be viewed by simply using the “+” and “-” buttons to scroll. Please note: Upon startup, the first screen shown is always Operational Information (battery's voltage and tachometer).

- Operational Information (Default screen)
- Alarm Status
- Engine Hours
- Job Timer
- Service menu
- Diagnostic menu
- Machine number
- About

Operational Information - This is the default screen. It displays the battery's voltage and tachometer - current engine speed in rpm.

Alarm status – Shows if there is an alarm from the MT05 communication of the Kohler engine or from the CO shut-off module.

Engine Hours – Displays the total number of hours – idle mode and clutch engaged.

Job Timer - The job timer acts as a stopwatch, but only starts when the machine works with clutch engaged. This allows you to accurately time how long your engine runs for a particular job.

Service menu – When you enter this menu, you have access to the service intervals of the machine. Alarm message indicates when an interval is over. Then you should take particular action and reset the interval.

Diagnostic menu - When you enter this menu, you have access to the CO shut-off module status and the clutch state (engaged or not).

Machine number – The machine serial number is entered here from the manufacturer.

About – This screen displays the manufacturer name. Hardware and software version too.

LED Alerts & Resetting Service Intervals

The SA LPG Controller will alert you when service is due. To reset the service interval see text above – Service Alerts.

The SA LPG Controller will indicate high levels of Carbon Monoxide. For LED color codes, see CO SHUT-OFF MODULE specifications, page 22.

The SA LPG Controller will also indicate Kohler engine fault codes. For details, see table below.

Safety Information

Safety Information- Read all safety information before using this device to ensure safe and proper use.

Do not interact with the device while operating your equipment. Doing so may distract your attention and cause an accident, or may be illegal depending on your region.

Avoid any direct contact with pressure washers, water sprayers or cleaning chemicals of any kind.

Do not drop or cause an impact to the device.

Do not bend or twist the device and/or the wire harness excessively.

Do not disassemble, modify or repair your device. This product contains no user serviceable parts.

FCC Part 15.21

Any changes or modifications to this device that are not expressly approved by the manufacturer may void the user's authority to operate the device.

Diagnostic Fault Code Summary

Fault Code	Connection or Failure Description	Fault Code	Connection or Failure Description
0031	Oxygen Sensor Heater Circuit High Voltage	0174	Lean Fuel Condition at High Load (Open Loop) or Insufficient Fuel Supply.
0032	Oxygen Sensor Heater Circuit Low Voltage		
0107	Manifold Absolute Pressure Sensor Circuit Low Voltage or Open	0201	Injector 1 Circuit Malfunction
0108	Manifold Absolute Pressure Sensor Circuit High Voltage	0202	Injector 2 Circuit Malfunction
0112	Intake Air Temperature Sensor Circuit Low Voltage	0230	Fuel Lock-off Circuit Low Voltage or Open
0113	Intake Air Temperature Sensor Circuit High Voltage or Open	0232	Fuel Lock-off Circuit High Voltage
0117	Coolant/Oil Temperature Sensor Circuit Low Voltage	0336	Crankshaft Position Sensor Noisy Signal
0118	Coolant/Oil Temperature Sensor Circuit High Voltage or Open	0337	Crankshaft Position Sensor No Signal
0122	Throttle Position Sensor Circuit Low Voltage or Open	0351	Cylinder 1 Ignition Coil Malfunction
0123	Throttle Position Sensor Circuit High Voltage	0352	Cylinder 2 Ignition Coil Malfunction
0131	Oxygen Sensor 1 Circuit Low Voltage, or Open	0562	System Voltage Low
0132	Oxygen Sensor 1 Circuit High Voltage	0563	System Voltage High
0171	Maximum Adaptation Limit Exceeded		
0172	Minimum Adaptation Limit Exceeded	61	End of Code Transmission

7.8 ELECTRONICS MODULE OF DIGITAL FUEL CONTROL SYSTEM

The block diagram only shows the flow using the "Plus" key on the keyboard. The "Minus" key reverses the direction of the flow. If there is "L" in the corresponding button, then you have to hold it for a couple of seconds

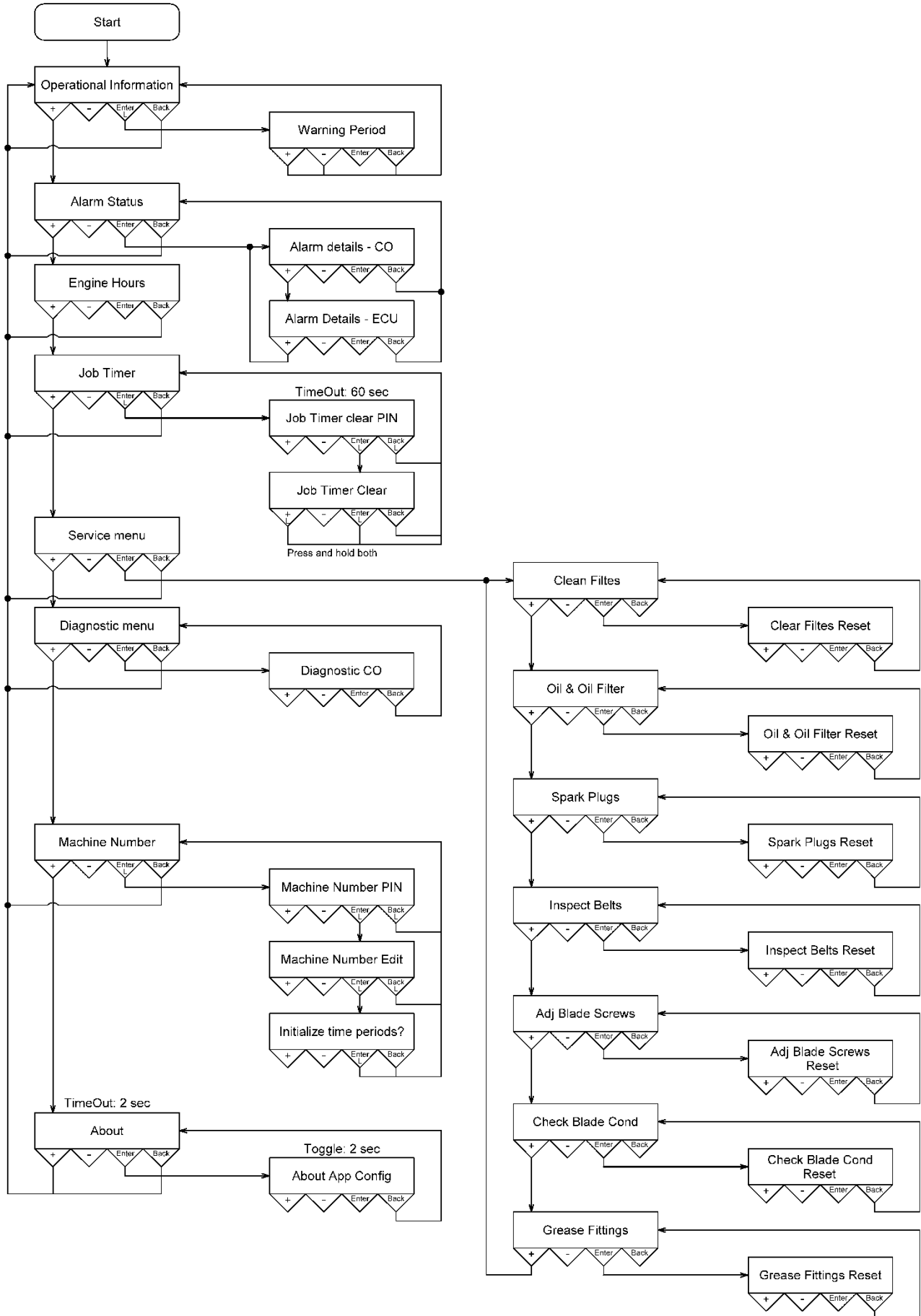

8. TOOLS AND ACCESSORIES

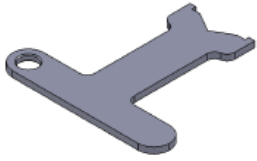

Figure 8.1

Tool holder key

The tool holder key (Fig. 8.1) is used for adjusting, mounting and dismounting of the foam plates. Always use the key for mounting. Item number is A03.00.00.00

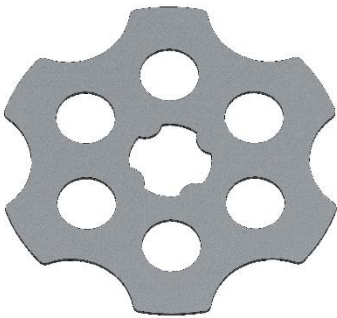

Figure 8.2

Security plate for Quickchange pads

Plate (Fig.8.2) used to ensure the “Quickchange” tools. Item number is A64.00.01

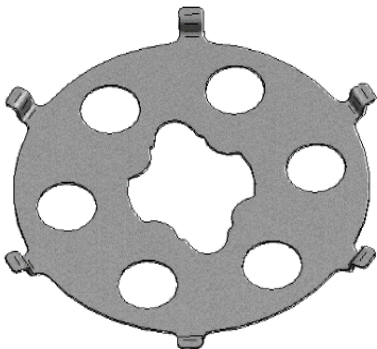

Figure 8.3

Security plate for RING TOOLS

Plate (Fig.8.3) used to ensure the “Ring” tools. Item number is A84.00.00

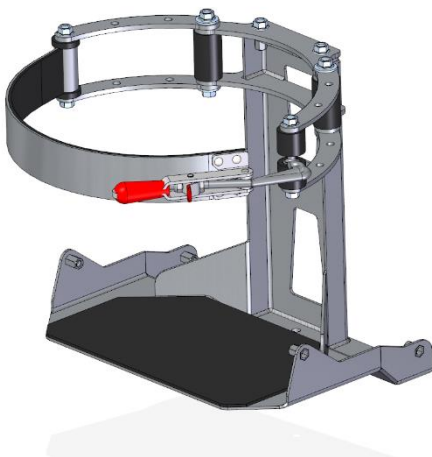

Figure 8.4

Holder for vertical propane tank

Item number is LP36GE90.00.00

9. POPULAR TOOLS

RECOMMENDED TOOLS



QuickChange System and Tooling feature extremely fast and convenient tool changes, and a long tool life, providing for great long-term cost savings. The QuickChange pads are produced in four different bonds for super hard, hard, medium and soft concrete, in a variety of grit sizes. They are offered with 1 or 2 buttons or rectangular segments, which allows you to customize the aggressiveness of the cut.

The new Corsa hybrid discs are designed for scratch removal and transitioning from metal to resin tools, and are similar to Calibra but the ceramic bond has been modified for more efficient use on soft and medium concrete.



NATO® WITH QUICK CHANGE ATTACHMENT

Superabrasive's Nato resin pucks are a great tool choice for soft and hard concrete polishing applications. Among the thickest diamond pads on the market - featuring a thick 12mm layer of resin and diamonds for extra long life. Wide channels and a unique patented design allow for work on a cleaner surface, ensuring a quality polish. Offered in wet and dry bond.

HYBRID AND RESIN TOOL RINGS

Exceptional flexibility with a thick layer of flexible foam.
Quick and easy magnetic attachment directly to the grinding heads.
Offered in 9" and 13" – Compatible with Lavina grinders and trowels.

Use Only Superabrasive's Recommended Tools.
For More Tooling Options, Visit www.superabrasive.com



10. MAINTENANCE AND INSPECTION

Tampering w/emission control system prohibited.

Federal law and California State law prohibits the following acts or the causing thereof:

1. The removal or rendering inoperative by any person other than for purposes of maintenance, repair, or replacement, of any device or element at design incorporated into any new engine for the purpose of emission control prior to its sale or delivery to the ultimate purchaser or while it is in use.
2. The use of the engine after such device or element of design has been removed or rendered inoperative by any person.

Among those acts presumed to constitute tampering, involve the parts/systems listed below:

- Carburetor and internal parts ;
- Spark plugs ;
- Magneto or electronic ignition system;
- Fuel filter element;
- Air cleaner elements;
- Crankcase;
- Cylinder heads;
- Breather chamber and internal parts;
- Intake pipe and tube;

WARNING!

Before cleaning and servicing the machine, you must turn the machine off and disconnect battery and propane tank.

ATTENTION!

- The exhaust will get very hot after running the engine for just a short time.
- Before moving the machine from the working area, the machine must be cleaned.
- All other equipment must be considered to be contaminated and be treated thereafter.
- If possible, use a special suitable room.
- Proper personnel protective equipment must be used.
- After a service, all parts that are contaminated must be taken care of properly in plastic bags, according to all regulations.
- If the machine has to be used for other purposes, it is extremely important that the machine is cleaned to avoid the spread of hazardous dust.

IMPORTANT: All major repair work should be performed by Superabrasive or an authorized repair facility.

Check and clean the Propane installation.

10.1 CHECK DAILY

After operating the LP36GE, the operator should conduct a visual inspection of the machine. Any defect should be solved immediately.

10.2 CHECK AND REPLACE AFTER THE FIRST 8 WORKING HOURS

Replace the oil in the engine after the first 8 hours work, according to the instructions of the engine manufacturer.

ALWAYS USE 30HD OR 10W-30 ENGINE OIL WITH ALL OF THE FOLLOWING RATINGS: SF, SG, AND CC.

10.3 CHECK AND REPLACE EVERY 100 WORKING HOURS

Change engine oil, while changing check for leakage of engine oil at the various seals. The hour meter will blink between 48-52 hours as a reminder/"Engine Oil Capacity" is 1.6 L (1.7 U.S. qt.) when oil filter is not removed and 1.9L (2.0 U.S. qt.) when oil filter is removed.

10.4 RECOMMENDED OIL CHANGE INTERVALS

Do not exceed the 100-hour oil change interval. Oil changes more frequent than 50 hours will give even longer engine life. In any case, always use 30HD or 10W-30 engine oil with all of the following ratings: SF, SG, and CC. make sure the oil level is maintained at the "FULL" level.

Table 8.4

OPERATION	INTERVAL							
	Daily	First 8 Hrs.	Every 50 Hrs.	Every 100 Hrs.	Every 200 Hrs.	Every 300Hrs.	Every 400Hrs.	Every 500Hrs.
Check & add engine oil	X							
Check for loose or lost fasteners	X							
Check for oil leakage	X							
Inspect fuel hose and connections	X							
Clean engine dust filter	X							
Inspect throttle & wire	X							
Change engine oil			X					
Change engine oil filter			X					
Check & clean primary air filter				X				
Check secondary air filter				X				
Inspect battery and battery connections				X				
Replace engine primary air filter						X		
Replace engine pre filter								X
Inspect, clean & re-gap spark plugs, Replace if necessary								X
Check & adjust valve clearance * Re-torque heads *						X		
Clean & lap valve seating surface *						X		
Check engine emissions								X

* Return machine to authorized service center for overall checkup of the Engine. For Propane safety, have the machine serviced by a Certified Technician, including emission check.

IMPORTANT: You can find more specific information about maintaining the engine by downloading it's manual at <https://kohlerpower.com/en/engines/product/command-pro-efi-propane-pcv740>.

10.5 TROWEL MAINTENANCE SCHEDULE

Table 10.5

TROWEL MAINTENANCE SCHEDULE							
Check item	Operation	Daily	Periodic maintenance interval				
			Every 25 Hrs	Every 50 Hrs	Every 100-125 Hrs	Every 500 Hrs	Every 10000 Hrs
Relube arms and cross shaft.	Grease	X					
Remove, clean, reinstall and relube arms.	Clean				X		
Check and replace, if necessary, arm bushings and thrust collar bushings.	Check			X			
Check blades for excessive wear or damage and replace if necessary.	Check	X					
Adjust blade speed if necessary.	Check					X	
Central gearbox lubricant (Synthetic Oil).	Replace (1.1liter)						X
Central gearbox lubricant	Check			X			
Drive belt.	Check			X			
Fasteners.	Check	X					

- Right and left gearbox are filled with 1,8l synthetic oil (KLÜBER Klübersynth GH 6-220, MOBIL Glygoyle 220, SHELL Omala S4 WE 220), providing lubrication – assuming pollution-free surroundings – «for life».
- Central gearbox are filled with 1.1l synthetic oil (MOBIL SHC-630).

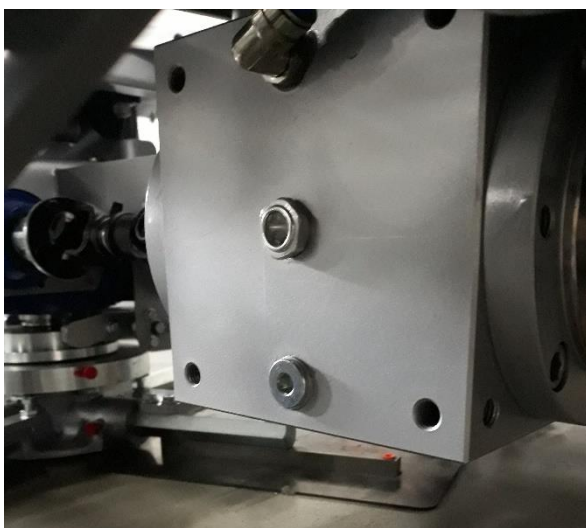

10.6 TROWEL LUBRICATION

Regular lubrication is required to maintain your trowel in optimal working condition. Schedule maintenance lubrication according to Table 10.6 below.

Table 10.6

Trowel lubrication schedule		
Location	# of shots	Interval
Spiders	1 to 1 1/2	Every day
Universal joint	1	Once a week/50 hours
Pitch levers	1	Once a month/150 hours
Pitch towers	1	6 month/900 hours

- Spiders (Daily):
Perform the following lubrication procedure after every 8 hours of use.
 - ✓ Locate one of the Zerk grease fittings on either spider assembly (fig. 10.6.1). Remove the Zerk fitting cap and set it aside.
 - ✓ Wipe the Zerk grease fitting to prevent abrasive material from entering the fitting during lubrication.
 - ✓ Lubricate the Zerk grease fitting with 1-1 ½ shots of multipurpose grade grease. Replace the Zerk grease-fitting cap when finished.
 - ✓ Repeat the those three steps for the remaining grease fittings on both spider assemblies.

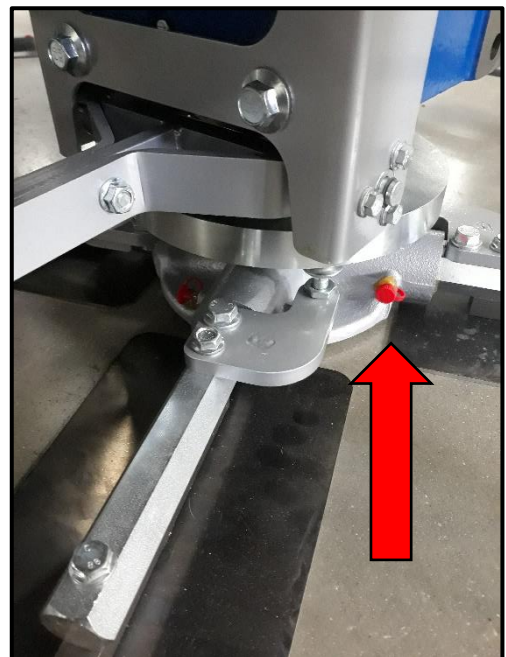

Figure 10.6.1

- Universal joint

Remove the front cover and locate the Zerk grease fittings on the Universal joint. Lubricate the Zerk grease fittings 1 – 2 shots of grease *Mobilux EP 2*.

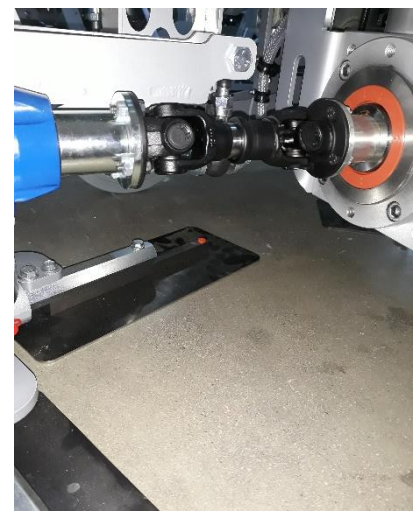

Figure 10.6.2

➤ Lifting lever system

Remove the front cover and locate the Zerk grease fittings. Lubricate the Zerk grease fitting with 1-1 ½ shots of multipurpose grade grease.

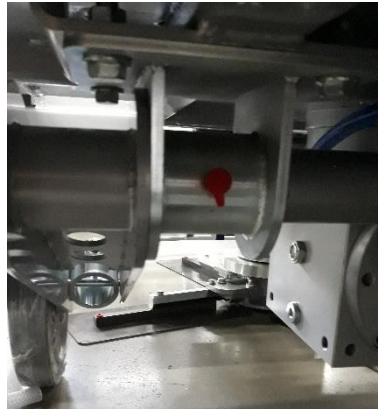

Figure 10.6.3

10.7 BELT MAINTENANCE

8.7.1 BELT INSPECT

Long life can be expected for this drive assembly as long as the drive belt is kept properly.

We recommend inspecting the belt every 100h for cracks appearing on the sides of the belt and/or in between the cogs underneath the belt.

10.7.2 REPLACEMENT OF THE DRIVE BELT

- **In order to mount the belt off do the following steps:**
1. Dismount the tank from the trowel.
 2. Dismount the tank holder.
 3. Dismount the bearing cap by unscrewing the four bolts.
 4. Dismount the belt cover.
 5. Loosen the bolts that hold the engine plate.
 6. Now the engine is able to move and the belt is loosened.
 7. Take out the belt and replace it.
- **To mount the belt follow the same steps in reversed order.**

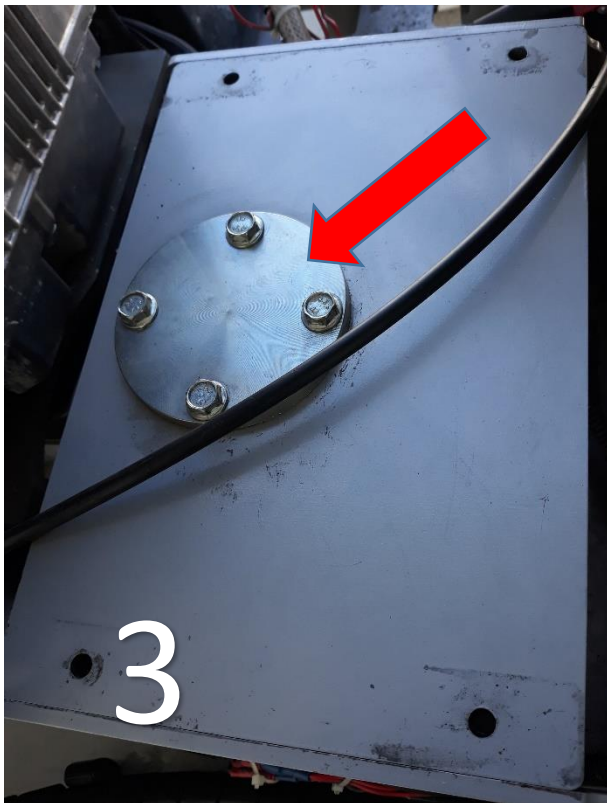
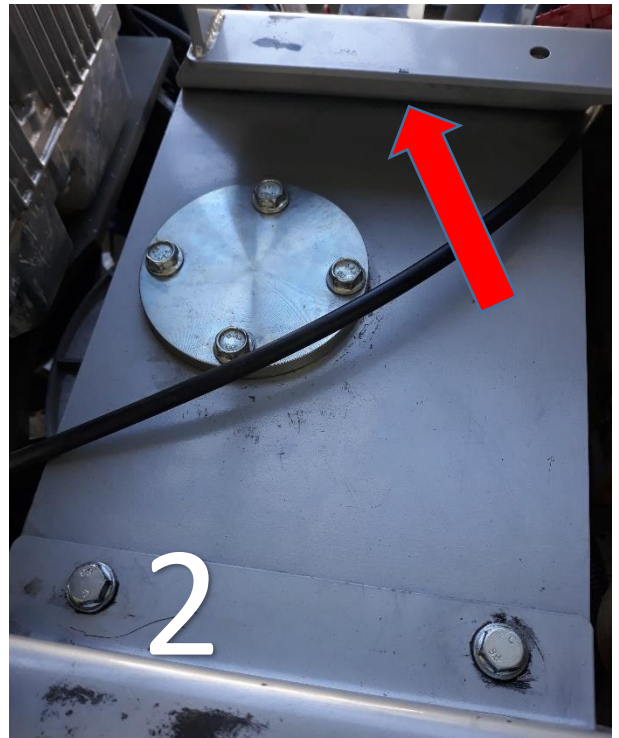

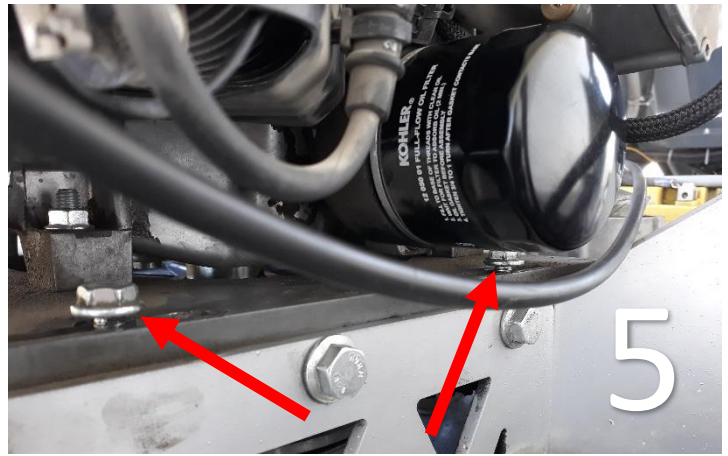

10.8 LAVINA® LP36GE ELECTRIC CIRCUIT DIAGRAM

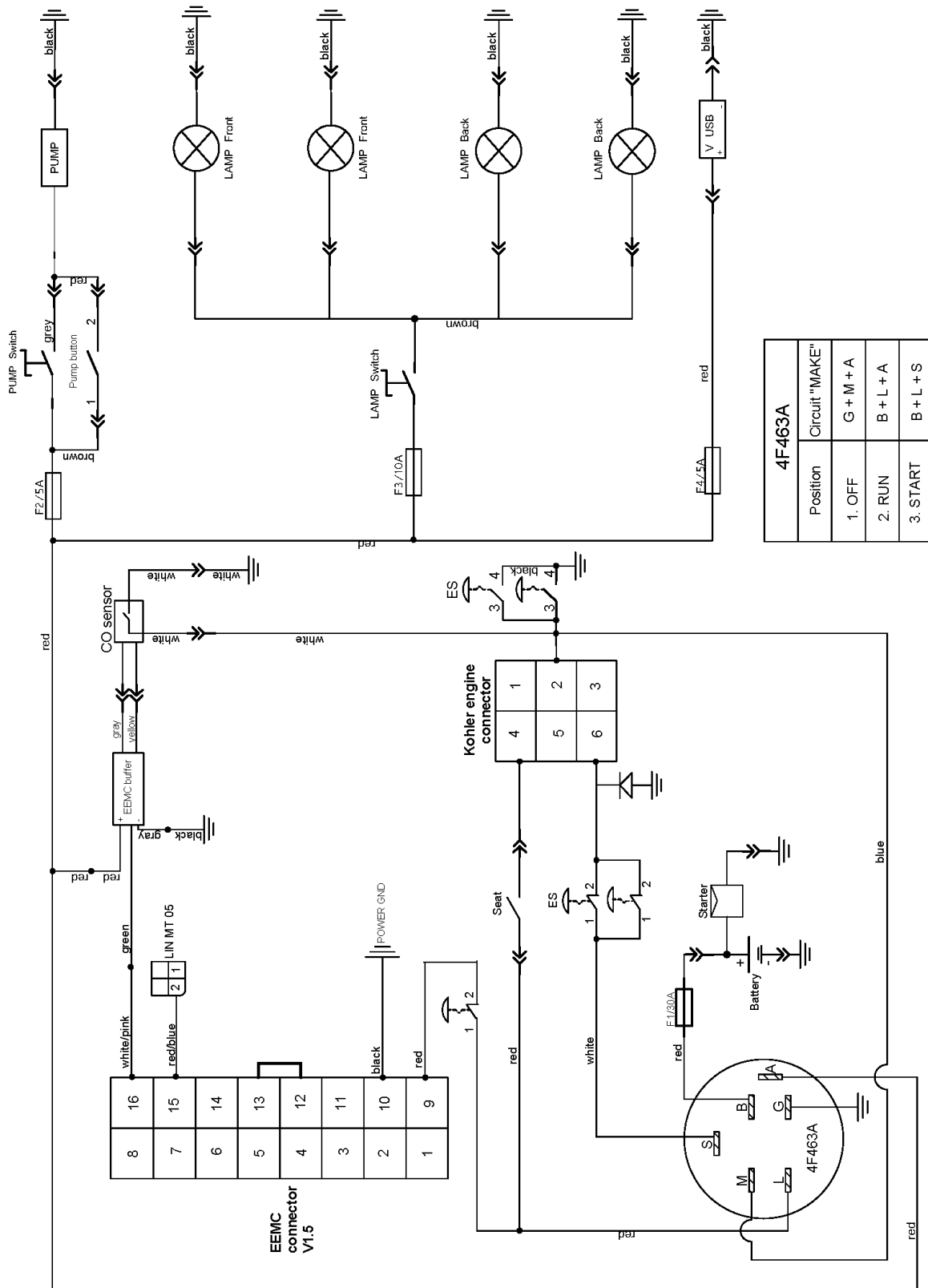

11. TROUBLESHOOTING

Index of Problems and Solutions

Engine

When troubles occur, be sure to check the simple causes which at first, may seem too obvious to be considered. For example, a starting problem could be caused by fuel starvation due to an empty propane cylinder or an unopened service valve. If you do not check for this, starter burnout could result.

Some Troubles and solutions: Surging idle

To smooth out the engines' idle characteristics, adjustment is provided by an idle screw on the lower right side of the carburetor as viewed from the muffler position. Rotating the screw clockwise will increase the idle speed and this should cure the "surging idle". If it does not, call our customer service.

Starter barely turns the engine over or the solenoid just clicks:

The battery is likely low in charge. This can be remedied by recharging the battery using a 12 Volt battery charger at 4.12 amperes. The battery is located under the frame. The positive post is the one with the RED cable attached to it. Follow the instructions that came with the battery charger. REMINDER: this will continue to happen unless your engine is run for sufficient time between starts to recharge the battery.

12. DISPOSAL

If your machine after time is not usable or needs to be replaced, send the machine back to Superabrasive or a local distributor, where a professional disposal complying with the environment laws and directives is guaranteed.

13. MANUFACTURER'S CONTACTS

If you need to contact Superabrasive Inc. with technical support questions, below is the contact information.

Address: 9411 Jackson Trail Road, Hoshton GA 30548, USA

Email: info@superabrasive.us

Tel.: 706 658 1122

Fax: 706 658 0357

Website: www.superabrasive.com

14. EMISSION CONTROL WARRANTY STATEMENT

CALIFORNIA EMISSION CONTROL WARRANTY STATEMENT YOUR WARRANTY RIGHTS AND OBLIGATIONS

The California Air Resources Board and Superabrasive Inc. are pleased to explain the emissions control system warranty on your 2016 small off-road engine (SORE). In California, new SORE must be designed, built and equipped to meet the State's stringent anti-smog standards. Superabrasive Inc. must warrant the emission control system on your SORE for the period of time listed below provided there has been no abuse, neglect or improper maintenance of your SORE.

Your emission control system may include parts such as the carburetor, fuel-injection system, the ignition system, catalytic converter, fuel tanks, fuel lines, fuel caps, valves, canisters, filters, vapor hoses, clamps, connectors, and other associated emission-related components.

Where a warrantable condition exists, Superabrasive Inc. will repair your SORE at no cost to you including diagnosis, parts and labor.

MANUFACTURER'S WARRANTY COVERAGE

The emission control system is warranted for 2 years. If any emission-related part on your equipment is defective, the part will be repaired or replaced by Superabrasive Inc.

OWNER'S WARRANTY RESPONSIBILITIES

As the small off-road engine (SORE) owner, you are responsible for the performance of the required maintenance listed in your owner's manual. Superabrasive Inc. recommends that you retain all receipts covering maintenance of your SORE engine, but Superabrasive Inc. cannot deny warranty solely for the lack of receipts or for your failure to ensure the performance of all scheduled maintenance.

As the SORE owner you should however be aware that Superabrasive Inc. may deny your warranty if your SORE or its part has failed due to abuse, neglect, improper maintenance or unapproved modification.

You are responsible for presenting your utility equipment engine to a Superabrasive Inc. distribution center as soon as the problem exists. The warranty repairs should be completed within a reasonable amount of time, not to exceed 30 days. If you have any questions regarding your warranty rights and responsibilities, you should contact Superabrasive Inc. at 1-(800)-987-8403 or by e-mail at info@superabrasive.us

Superabrasive Inc

9411 Jackson trail Rd

Hoschton, GA

USA, 30548

GENERAL EMISSIONS WARRANTY COVERAGE

Superabrasive Inc. warrants to the ultimate purchaser and each subsequent purchaser that the equipment is:

Designed, built and equipped so as to conform with all applicable regulations; and

Free from defects in materials and workmanship that cause the failure of a warranted part to be identical in all material respects to that part as described in Superabrasive Inc. application for certification.

The warranty period begins on the date the equipment is delivered to an ultimate purchaser or first placed into service. The warranty period is two years.

Subject to certain conditions and exclusions as stated below, the warranty on emission-related parts is as follows:

- (1) Any warranted part that is not scheduled for replacement as required maintenance in the written instructions supplied, is warranted for the warranty period stated above. If the part fails during the period of warranty coverage, the part will be repaired or replaced by Superabrasive Inc. according to subsection (4) below. Any such part repaired or replaced under warranty will be warranted for the remainder of the period.
- (2) Any warranted part that is scheduled only for regular inspection in the written instructions supplied is warranted for the warranty period stated above. Any such part repaired or replaced under warranty will be warranted for the remaining warranty period.
- (3) Any warranted part that is scheduled for replacement as required maintenance in the written instructions supplied is warranted for the period of time before the first scheduled replacement date for that part. If the part fails before the first scheduled replacement, the part will be repaired or replaced by Superabrasive Inc. according to subsection (4) below. Any such part repaired or replaced under warranty will be warranted for the remainder of the period prior to the first scheduled replacement point for the part.
- (4) Repair or replacement of any warranted part under the warranty provisions herein must be performed at a warranty station at no charge to the owner.
- (5) Notwithstanding the provisions herein, warranty services or repairs will be provided at all of our distribution centers that are franchised to service the subject engines or equipment.
- (6) The SORE owner will not be charged for diagnostic labor that is directly associated with diagnosis of a defective, emission-related warranted part, provided that such diagnostic work is performed at a warranty station.
- (7) Superabrasive Inc. is liable for damages to other engine or equipment components proximately caused by a failure under warranty of any warranted part.
- (8) Throughout the SORE warranty period stated above, Superabrasive Inc. will maintain a supply of warranted parts sufficient to meet the expected demand for such parts.
- (9) Any replacement part may be used in the performance of any warranty maintenance or repairs and must be provided without charge to the owner. Such use will not reduce the warranty obligations of Superabrasive Inc.
- (10) Add-on or modified parts that are not exempted by the Air Resources Board may not be used. The use of any non-exempted add-on or modified parts by the ultimate purchaser will be grounds for disallowing a warranty claim. Superabrasive Inc. will not be liable to warrant failures of warranted parts caused by the use of a non-exempted add-on or modified part.

WARRANTED PARTS

The repair or replacement of any warranted part otherwise eligible for warranty coverage may be excluded from such warranty coverage if Superabrasive Inc. demonstrates that the SORE has been abused, neglected, or improperly maintained, and that such abuse, neglect, or improper maintenance was the direct cause of the need for repair or replacement of the part. That notwithstanding, any adjustment of a component that has a factory installed, and properly operating, adjustment limiting device is still eligible for warranty coverage. The following emission warranty parts are covered:

- (1) Catalytic converter
- (2) Fuel system: Carburetor, pressure regulator and fuel lock off
- (3) Ignition system
- (4) Intake system including pre-filter
- (5) Exhaust manifold