

LAVINA®



LAVINA® 25L-S User Manual



Tech Support Line: 800-987-8403 | www.superabrasive.com | info@superabrasive.us



WARRANTY CARD

A warranty card must be submitted to Superabrasive within 30 days of purchase in order for the foregoing warranty to apply. See next page for more details on LAVINA warranty and return policies.

Print and mail this form. Or fill out and submit our **ONLINE WARRANTY FORM**

Customer Information

Customer Name

Business Name

Street Address

Street Address line 2

City

State

Zip Code

Phone Number

Email Address

Machine Information

Model

Serial Number

Purchased from / Distributor Name

Purchase date

SUPERABRASIVE Inc.
9411 Jackson Trail Road, Hoschton, GA 30548, USA
Tel.: 1 706 658 1122 | Toll Free: 1 800 937 8403 | Fax: 1 706 658 0357
E-mail: info@superabrasive.us | www.superabrasive.com

WARRANTY AND RETURNS

WARRANTY POLICY FOR LAVINA® S MACHINES

A warranty card must be submitted to Superabrasive within 30 days of purchase in order for the foregoing warranty to apply.

You can either mail a hard copy of the warranty card or submit it electronically - see page 2.

Superabrasive warrants, from the time of delivery and receipt by the original customer, new and unused products sold by Superabrasive or Superabrasive-appointed distributors or dealers. Goods shall be free from defects in materials and workmanship. Superabrasive or a Superabrasive-appointed repair facility shall either replace or repair any defects in the Goods resulting from faulty design, materials, or workmanship. Products repaired or replaced during the warranty period shall be covered by the foregoing warranty for the remainder of the original warranty period, or ninety (90) days from date of the repair or shipment of the replacement, whichever is longer. Spare parts for repair will be either new or equivalent to new.

Warranty period shall be 2 years from the time of delivery and receipt by the original customer, or 600 operating hours on the machine - whichever occurs first. Superabrasive will cover the shipping charges for the transportation of the machine to Superabrasive (or an approved repair facility) and back to the customer (within the contiguous 48 United States) in the event that the damage occurs and is reported within the first 90 days or 200 operating hours - whichever occurs first. Shipping charges, if covered by Superabrasive, must be agreed upon in advance and approved by Superabrasive. Thereafter, the customer will have to cover the shipping charges to Superabrasive and back. Superabrasive will not warranty Goods after a period of 2 years from the time of delivery and receipt by the original customer, or 600 operating hours on the machine - whichever occurs first.

Superabrasive shall not be liable for any defects that are caused by circumstances that occur after the Goods have been delivered and whilst the Goods are in the possession of the purchaser. Furthermore, the warranty does not include normal wear and tear or deterioration. Wear parts are not warranted. Superabrasive is not liable for defects arising out of use of non-OEM parts.

The Warranty is void if the purchaser has not followed the maintenance plan stipulated by the machine's manual and warranty card. The warranty is void if the purchaser repairs said Goods himself, or if repairs are conducted by a repair facility that is not approved by Superabrasive. Superabrasive's liability does not cover defects which are caused by faulty maintenance, incorrect operation, faulty repair by the purchaser, or by alterations conducted without Superabrasive's prior written consent. The same applies to any alterations of the Goods or services performed by another party other than Superabrasive, a Superabrasive-appointed distributor, or a Superabrasive-approved repair facility. The warranty is not applicable on a defect that arises due to tools or parts that are not original to Superabrasive. Replaced defective parts shall be placed at Superabrasive's disposal and shall become property of Superabrasive. If such defective parts are replaced

within the warranty period, the shipping charges will be covered by Superabrasive. In warranty complaint cases, when no defects are found for which Superabrasive is liable, Superabrasive shall be entitled to compensation for the labor, material cost, and shipping charges, incurred by Superabrasive as a result of the complaint.

The warranty herein is non-transferable, and only applies to the original owner or purchaser of the machine.

RETURN POLICY FOR LAVINA® S MACHINES

The Lavina® S machines may be returned, subject to the following terms:

In no case, a machine is to be returned to Superabrasive Inc. for credit or repair without prior authorization. Please contact Superabrasive Inc. or your local distributor for an authorization and issuance of a return authorization number. This number along with the serial number of the machine must be included on all packages and correspondence. Machines returned without prior authorization will remain property of the sender and Superabrasive Inc. will not be responsible for them. No machines will be credited after 90 days from the date of invoice.

All returns must be shipped freight prepaid. Returned machines may be exchanged for other equipment or parts of equal dollar value. If machines are not exchanged, they are subject to a fifteen percent (15%) restocking fee.

WARRANTY AND RETURNS	3		
1. GENERAL INFORMATION			
Preface	5		
Manufacturer	5		
General Description	5		
Machine Characteristics	5		
Main Design	5		
Environmental Conditions	5		
Electrical Connection	5		
Vacuum Connection	6		
Technical Data	6		
Vibrations	6		
Sonorous Emissions	6		
Label Data	6		
Customer Service	6		
2. SAFETY INSTRUCTIONS			
Recommended Use	6		
Prohibited Use	6		
Preparation for Work	6		
Protection Devices	7		
Arrest Functions	7		
Safe Use	7		
Residual Risks	7		
Before You Begin	7		
Operating Machine	7		
After Work is Completed	7		
The Work Area	7		
Personal Protective Equipment (Ppe)	7		
Operator	7		
3. HANDLING AND TRANSPORTATION			
Preparing the Machine for Transportation	8		
Lift the Machine from Working to Tool Mounting			
Position	8		
Lifting	8		
Adjusting the Handle	8		
Storage	9		
4. OPERATION			
Preliminary Controls	9		
Water Flow Control Unit	9		
Adjusting and Mounting Tools	9		
Frame Blocking (U-Joint)	9		
Control Board	10		
Starting the Machine	10		
Operating the Machine	10		
Stopping Machine	10		
Alarm	10		
5. TOOLS AND ACCESSORIES			
Weights	11		
Tool Holder Key	11		
Foam Plate	11		
Security Plate for Quickchange Pads	11		
6. POPULAR TOOLS	12		
7. EXPLODED VIEW			
General Exploded View (Fig.7.1)	13		
Top Cover Exploded View 1 (Fig.7.2)	13		
Planetary Drive Exploded View (Fig.7.3)	13		
Top Cover Exploded View 2 (Fig.7.4)	13		
Bottom Cover Exploded View 1 (Fig.7.5)	14		
Bottom Cover Exploded View 2 (Fig.7.6)		14	
			Pulley Units Exploded View (Fig.7.7)
			Carriage Exploded View (Fig.7.8)
			Tool Holder Exploded View (Fig.7.9)
			8. MAINTENANCE AND INSPECTION
			Cleaning
			Check Daily
			Check and replace after the first 15 Working Hours
			Check Every 200 Working Hours
			Check Every 400 Working Hours
			Vacuum
			Water Leaks
			Mechanical Parts
			Electrical System
			Electrical Schemes 200-240 Volt
			Electrical Schemes 380-480 Volt
			9. TROUBLESHOOTING
			Index of Problems and Solutions
			9.1 Replacing Power Cord and Plugs
			9.2 Dismounting and Mounting Tool Holder to change buffers and spiders, changing V-Rings and Felt-Rings
			9.3 Tensioning and Replace the Planetary Belt
			9.4 Tensioning Used Planetary Belt
			9.5 Mounting and Tensioning a new Planetary Belt
			9.6 Checking the Tension of the Belt
			9.7 Replacing of the Pulley Units
			9.8 Mounting the Belt
			9.9 Motor Connection
			9.9 Fault Diagnosis Inverter YASKAWA V1000
			10. DISPOSAL
			Disposal
			11. MANUFACTURER'S CONTACTS
			Manufacturer's contract
			12. SPARE PARTS
			1. General Parts /for machine produced before Jan.1 2014/
			1. General Parts /for machines produced after Jan.1 2014/
			2. Top Cover Parts 1/for machines produced before Jan.1 2014/
			2. Top Cover Parts 1/for machines produced after Jan.1 2014/
			3. Top Cover Parts 2
			4. Planetary Drive Parts
			5. Guard Parts
			6. Bottom Cover Parts 1
			7. Bottom Cover Parts 2
			8. Pulley Units Parts
			8a. Pulley Unit Assembly
			8b. Driving Pulley Unit
			9. Water Supply Parts/for machines produced before Jan.1 2014/
			9. Water Supply Parts/for machines produced after Jan.1 2014/
			10. Tool Holder Parts
			11. Carriage Parts/for machines produced before Jan.1 2014/
			11. Carriage Parts/for machines produced after Jan.1 2014/
			12. Control Box Parts 200-240 Volt
			13. Control Box Parts 380-480 Volt

1. GENERAL INFORMATION

This owner's manual is intended for the operator of the Lavina® S machine, the servicing technician as well as for anyone involved with operating or servicing the machine. We recommend that you read the instructions very carefully and follow them strictly. The manual includes information about assembling, using, handling, adjusting and maintaining your Lavina® S floor grinding and polishing machine.

MANUFACTURER

Superabrasive was founded in 1987, as a manufacturer of high quality diamond tools for the stone and concrete industry. Today, Superabrasive is one of the world's leading companies in the production of diamond tools and floor grinding machinery. At Superabrasive, we strive to deliver the very best solutions to our customers, and enable them to work more efficiently.

GENERAL DESCRIPTION

The Lavina® S machine is intended for grinding, polishing and buffing concrete, marble, granite, limestone, and terrazzo surfaces with diamond tools.

The Lavina® S machine is a three-disc machine, which can be used dry as well as wet.

For best results, use only tools manufactured or recommended by Superabrasive and its distributors. Additionally, the machine could be used for grinding wood floor surfaces.

⚠ WARNING The Lavina® S machine is manufactured and fitted for the above-mentioned applications only! Every other use may possess risks to the persons involved.

MACHINE CHARACTERISTICS

The Lavina® S machine is made of two main component sections:

MAIN DESIGN

The two main component sections, are the carriage and main head.

The **handle** (Fig.1.2) on the frame is adjustable in height and allows the operator to work in a correct and safe working posture.

The **halogen spotlight** (Fig.1.2) enables the operator to work in darker areas.

⚠ WARNING Existing lighting system does not replace adequate overhead lighting.

- A **frame (U-joint technology)** on top of the motor base allows the main head to move to all sides and it gives more grinding capacity.
- The **controls** are positioned on top of the electrical box (fig.1.3)
- The **electrical box** (fig.1.3) contains the electric switching devices and the inverter.
- The **main feeding cable** is connected with a plug and socket on top. The motor feeding cable is plugged into the socket located on the bottom of the box.
- The **tank** is on the opposite side of the frame, so that the weight of the water has no influence on the operation of the machine. The frame weight, on the other hand, is fully absorbed by the driving wheels. An electric pump sprays the water through a front sprayer or internal.
- The **motor** is mounted on the base plate and is driving the three heads with a belt system.
- The **planetary head** is driven by a second flat belt.

ENVIRONMENTAL CONDITIONS

The temperature range for operating the Lavina® S machine outdoors is between 41°F and 86°F or 5°C and 30°C. Never use the Lavina® S machine during rain or snow when working outdoors. When working indoors, always operate the machine in well-ventilated areas.

ELECTRICAL CONNECTION

The voltage (Volt) and power (Ampere) are displayed on a label on the electrical control box to avoid any incorrect connection. Refer to these before connecting the power. To avoid electrical shocks, make sure the ground power supply is functioning properly.



Figure 1.1



Figure 1.2



Figure 1.3

VACUUM CONNECTION

A connection for a vacuum dust extractor is located on the carriage. The Lavina® S machine does not include a vacuum dust extractor. The customer must purchase the vacuum dust extractor separately. The hose of the vacuum extractor must be Ø 50 mm and can be glued over the pipe. The vacuum dust extractor must be adapted for floor grinders and have a minimum air displacement of 320m³/h with a negative vacuum of 21 kPa.

TECHNICAL DATA

	Lavina® 25L-S		Lavina® 25L-S-HV	
	Voltage/Hz	3 ph x 200-240V 50-60Hz		3 ph x 380-480V 50-60Hz
Amperage	Max 45 Amps		Max 30 Amps	
Power	11 kW	15 HP	11 kW	15 HP
Tool holder rpm	300-1100 rpm		300-1100 rpm	
Working width	655 mm	25"	655 mm	25"
Tool diameter (QC Plate)	3x 225 mm	3x 9"	3x 225 mm	3x 9"
Weight	292 kg	644 lbs	292 kg	644 lbs
Grinding pressure	171 kg	377 lbs	171 kg	377 lbs
Additional weight	max 2x 29 kg	max 2x 64 lbs	max 2x 29 kg	max 2x 64 lbs
Application	wet and dry		wet and dry	
Vacuum hose port	Yes		Yes	
Water tank capacity	20 l	5.2 gal	20 l	5.2 gal
Water feed	with pump (peripheral and front)		with pump (peripheral and front)	
Cable length	17.4 m	57 ft	17.4 m	57 ft
Machine LxWxH	1880x690x1180 mm	76x27.2x46.5"	1880x690x1180 mm	76x27.2x46.5"
Packing LxWxH on skid	1150x730x1530 mm	45.3x28.7x60.2"	1150x730x1530 mm	45.3x28.7x60.2"
Packing LxWxH Crate 1	1150x730x1100 mm	45.3x28.7x43.3"	1150x730x1100 mm	45.3x28.7x43.3"
+ Crate 2	1150x730x 900 mm	45.5x28.7x35.4"	1150x730x 900 mm	45.5x28.7x35.4"

VIBRATIONS

The vibrations of the machine are within the limits of directives and harmonized standards from the European Union when the Lavina® S is operated with the recommended tools and in normal conditions.

SONOROUS EMISSIONS

The sonorous emissions are within the limits of directives and harmonized standards from the European Union when the Lavina® S is operated with the recommended tools and in normal conditions. However, as previously stated, the operator must wear ear protectors.

LABEL DATA

The data on the label provides the correct Voltage and kW (needed for operational purposes); Weight (needed for transportation purposes); production year and serial number (needed for maintenance purposes).

CUSTOMER SERVICE

For customer assistance and technical support call your local distributor or call Superabrasive Inc. at 1-800-987-8403 or visit us at: www.superabrasive.com, where you can download a copy of this manual.

2. SAFETY INSTRUCTIONS**RECOMMENDED USE**  **WARNING**

The Lavina® S machine is designed and manufactured to grind and polish concrete, terrazzo, and natural stone floors. It can be used for renovation as well as for polishing. The machine is designed for dry or wet use. When using it dry, use a vacuum of appropriate size. For more information, please refer to the chapter on handling the vacuum connection.

PROHIBITED USE  **WARNING**

The machine MUST NOT be used:

- For applications different from the ones stated in the general description chapter.
- For non-suitable materials. In environments which:
 - Possess risks of explosion,

- Possess high concentration of powders or oil substances in the air,
- Possess risks of fire Feature inclement conditions,
- Possess electromagnetic radiation.

PREPARATION FOR WORK

Make sure that:

 **WARNING**

- You have closed the work area, so that no person unfamiliar with operating the machine can enter the area.
- The tool plate and tools are adjusted to the machine properly.
- There are no missing parts of the machine
- The machine is in upright working position.
- The protection devices are working properly.

- The electrical cable is free to move and follow the machine easily.
- In order to keep the electrical cable from being damaged, no vehicle should cross the zone where electrical cables are situated.

PROTECTION DEVICES WARNING

The machine is equipped with several protection devices including the following:

- An emergency stop button
- A protection skirt and a hood for protecting the tool plates.

These devices protect the operator and/or others persons from potential injuries. Do not remove them. Before using the machine, please ensure that all protection devices are mounted and function properly. The Security plate prevents the QuickChange pads to from loosening during work

ARREST FUNCTIONS WARNING

Functions of arresting of the machine are following:

- Button to stop the motor (category 1)
- Emergency button (category 1)

SAFE USE WARNING

The Lavina® S is designed to eliminate all risks correlated with its use. However, it is not possible to eliminate the risks of an eventual accident with the machine. Unskilled or uninstructed operator may cause correlated residual risks. Such risks are:

- Position Risks: due to operator's incorrect working position
- Tangling up Risks: due to wearing inappropriate working clothes
- Training Risks: due to lack of operational training.

NOTE: : In order to reduce all consequences of the above-mentioned risks, we advise that machine operators will follow the instructions in the manual at all times.

RESIDUAL RISKS WARNING

During the normal operating and maintenance cycles, the operator is exposed to few residual risks, which cannot be eliminated due to the nature of the operations.

BEFORE YOU BEGIN WARNING

- Working area must be clear from any debris or objects.
- A first-time operator must always read the manual and pay attention to all safety instructions.
- All electric connections and cables must be inspected for potential damages.
- Ground wire system of the power supply must be also inspected.
- Perform general daily inspections of the machine and inspect the machine before each use.
- Always inspect the safety devices: Mount the Security plate for the QuickChange pads.
- The emergency break must be clear and working
- The tool protector must be working
- The machine must be clean
- Never operate the machine in the rain!
- Confirm that there are no missing parts especially after

transportation, repair or maintenance.

- Before filling the water tank with water make sure the machine is not working and the main switch is turned off.
- Before turning on the machine make sure that the base is placed on the floor, the machine MUST NOT be in an upright position when turned on!

OPERATING MACHINE WARNING

When operating the Lavina® S, make certain that there is no one, but you around the machine.

Never leave the machine unattended while working.

The electrical cable must move freely and must be damage- free.

The water hose must move freely and must be damage-free. Check to make sure the floor, you are preparing to work on, is even. If the floor is uneven, it may damage the machine.

After Work is completed WARNING

- Clean the machine and its surroundings properly
- Empty and clean the water tank
- Unplug the machine and wind up the electrical cable
- Store the machine in a safe place

THE WORK AREA WARNING

- Make certain that people or vehicles do not enter the work area.
- Avoid cables and hoses being in the way.
- Always check the floor for debris

PERSONAL PROTECTIVE EQUIPMENT (PPE) WARNING

- Always wear safety shoes when working with the machine.
- Always wear ear protectors when working with the machine.
- All personnel in the immediate work area must wear safety glasses with side shields.
- Always wear safety gloves when changing the tools.
- Always wear clothes suitable for the work environment.

OPERATOR WARNING

The Lavina® S machine.

The operator must know the machine's work environment. Only one operator at a time can work with the machine. The operator must be properly trained and well instructed prior operating the machine.

- The operator must understand all the instructions in this manual.
- The operator must understand and interpret all the drawings and designs in manual.
- The operator must know all sanitation and safety regulations pertaining to the operation of
- The operator must have floor grinding experience.
- The operator must know what to do in case of emergency.
- The operator must have an adequate technical knowledge and preparation.

3. HANDLING AND TRANSPORTATION

PREPARING THE MACHINE FOR TRANSPORTATION



Figure 3.1



Figure 3.2



Figure 3.3

Unplug the motor cable plug from the control box and disconnect the water hose from the main head by pulling it out (Fig.3.1) (Fig.3.2). Wind the electrical cable on the carriage. Release the pin sets which attach the head to the carriage. Pull out the vacuum hoses (Fig.3.3), and dismount the head from the carriage.

The head of the LAVINA® S machine has one bar for support and is used as handles for easy moving and transportation.

LIFT THE MACHINE FROM WORKING TO TOOL MOUNTING POSITION

Push the front handle down and swivel it to the front (Fig.3.4). Pull the handle up and ensure the head is a stable upright position, for mounting/dismounting the tool. Ensure that the water tank is empty before flipping the machine. Pull the head in upright position (Fig.3.5). **The machines manufactured after Jan.1 2014 are with changed locking of the front handle as shown on the fig.3.4.1.**



Figure 3.4



Figure 3.4.1



Figure 3.5



Figure 3.6

LIFTING

Lifting the machine by crane is possible with the eye bolt, which is mounted on the carriage (see Fig. 3.6). The eye bolt and machine construction is rated only for the weight of the machine. Do not list any other leads on the machine. Always use hoisting equipment rated for 300 kg or 660 lbs.

ADJUSTING THE HANDLE

The Handle on the frame is adjustable in height and allows the operator to work in a correct and safe posture. **The machines manufactured after Jan.1 2014 are with changed locking of the handle on the frame.**



Figure 3.7



Figure 3.7.1

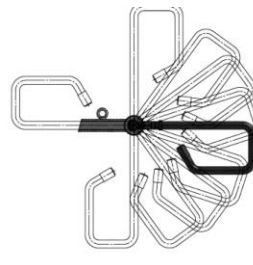

Figure 3.7.2



Figure 3.8

The unlocking is by pulling the handle (fig.3.4.1)The locking is automatically under action of the spring. Fig.3.7.2 shows all possible position of the handle. Choose the upright position to move easy the machine.

STORAGE

Always store and transport the Lavina® S machine in a dry place. Never transport the Lavina® S machine unprotected; it may be damaged if transported unprotected during rain or snow.



Figure 3.9



Figure 3.10



Figure 3.11

⚠ WARNING

When storing the machine the temperature may fall down to or to less than 32F (or 0° C) you should empty the water from the system using the following steps:

- Pull out the hose of the tank (Fig.3.9)
- Using compressed air blow out the water from the system for the two positions of the turn-cock (Fig. 3.10, Fig. 3.11).

4. OPERATION**PRELIMINARY CONTROLS**

Inspect the working area as explained in the safety instructions. For wet use, fill the water tank when the electrical cable is disconnected. Connect the vacuum extractor and ensure that the vacuum hose is clear and that it will easily follow the machine. Plug in the machine and make sure that the power cord is free to follow the direction of the working Lavina® S machine.

WATER FLOW CONTROL UNIT

The operator can choose the water sprayer in the front when the tap is in the horizontal position (Fig.4.1), the water



Figure 4.1



Figure 4.2



Figure 4.2.1

will spray under the cover of the machine when the level is in the vertical position (Fig.4.2). The flow regulating valve located on the tank (Fig.4.2.1) is increasing or reducing the water flow to the working area – in front of the machine or under the main head cover of the machine/only for machines produced after Jan.1 2014/.

ADJUSTING AND MOUNTING TOOLS

Mount the tools only after ensuring that there is enough diamond bond material left. Be sure that the plates are always clean before mounting. **WARNING:** Always secure the “QuickChange” pads with the security plate (Fig.4.3), lock with the tool holder key (Fig.5.3). Diamond tools with Velcro are attached to three 9inch foam plates (Fig.4.4). The foam plates are mounted on the key lock (butterfly). Always use the tool holder key (Fig.5.3).

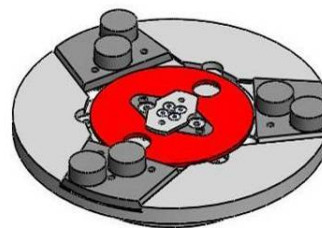

Figure 4.3



Figure 4.4



Figure 4.5

FRAME BLOCKING (U-JOINT)

The relation between the working head and the trolley is the frame (U-joint), which allows the rotation of two perpendicular axes to better follow the floors' profile.

The movement along the one axis can be secured with two screws (fig.4.5) and that blocks the lateral movement of the machine.

THE CONTROL BOARD

1. **Power cable plug**
2. **Digital RPM indicator** Indicates the revolution per minute of the grinding plates (not the revolution per minute of the entire unit).
3. **Polishing/Grinding switch** In “grinding” position, the operator has the possibility to control the rpm from 300 until maximum 700 rpm. In “Polishing” position from 300-1100 rpm maximum.
4. **Lamp cable gland**
5. **Inverter alarm led** Lights blue when the inverter goes into alarm mode.
6. **Water pump switch** Lights orange when the water pump is working.
7. **Power led** lights green when the power is on

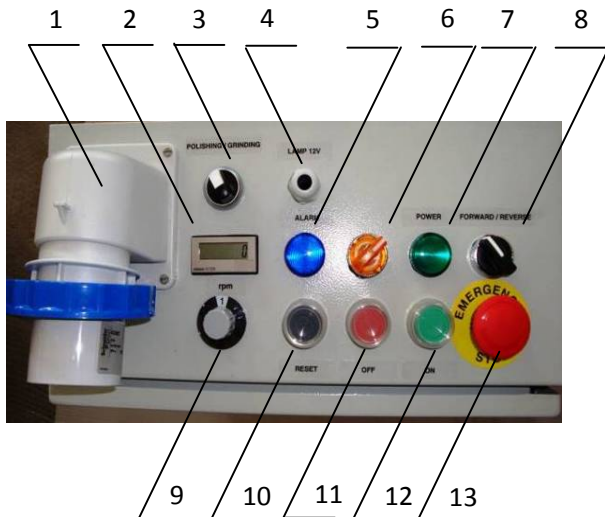

Figure 4.6

8. **Forward/Reverse switch** choose forward for clockwise rotation of the grinding plates or reverse for anti-clockwise rotation of the grinding plates
9. **Potentiometer** changes the RPM of the grinding plates from 300-1100 rpm
10. **Reset button** resets the alarm of the inverter
11. **OFF button** stops the motor
12. **ON button** starts the motor
13. **Emergency button** used in Emergency situations for stopping the motor

STARTING THE MACHINE

First, follow the directions in chapter Safety Devices and Safety Instructions. Next, pull the emergency stop (13) to ensure that the machine is in working condition. Check the potentiometer (9) and ensure that it is set at working speed. If working wet, add water to the floor's surface. If working dry, omit this step, and instead, switch on the vacuum unit. Finally, hold the machine firmly and push the start button (12).

OPERATING THE MACHINE

Guide the machine in straight lines across the floor, and with each new line overlap a little bit of the previously completed surface. Work at a constant speed, allowing the tools time to work at a speed appropriate for the tools' grit size. Avoid vibrations. Do not stop the Lavina® S on one spot while the tools are still working because they will leave marks on the floors' surface. When working wet, first choose the water tap (Fig.4.2) and the position for the water feed, periodically start to pump and release water onto the floor's surface (Fig.4.6 Pos.6). When working dry, check the floor's surface periodically to ensure that dust is not accumulating on the surface, also check regularly to make sure your vacuum is working properly.

STOPPING THE MACHINE

The stopping of the machine must be done gradually until the motor stops. Do not stop moving the machine before arresting the motor as the tools could damage the surface. To stop, push the “Off” button (11). Use the emergency button (13) only in emergency or use it to switch the power totally off. Remember not to hold the machine in one spot before turning off the motor.

ALARM

The alarm light (5) will light in case inverter goes into alarm mode. The most common failure is motor in overload. To reset the mode, push the “reset” button (10).

5. TOOLS AND ACCESSORIES



Figure 5.1

WEIGHTS

Superabrasive offers additional weights for increasing the productivity of the machine (Fig.5.1). Each additional weight weighs about 64 lbs or 29kg. Each individual application, type and condition of surface, power capacity of the outlet, etc. will determine the number of weights you can use without tripping a breaker. The weight stacks onto three posts that are around the outer bowl (Fig.5.2). The additional weights depend on the tools; it is not always possible to ass weights. Some tools work too aggressively and the machine can stop. The weight can be ordered with item number A08.00.00.00



Figure 5.2

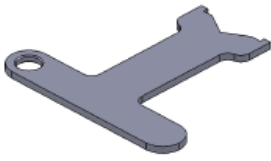

Figure 5.3

TOOL HOLDER KEY

The tool holder key (Fig.5.3) is used for adjusting, mounting and dismounting of the foam plates. Always use the key for mounting. Item number is A03.00.00.00

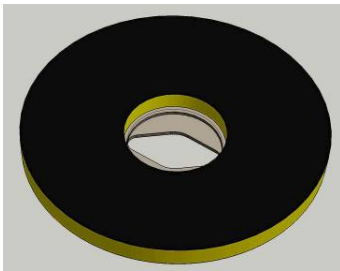

Figure 5.4

FOAM PLATE

Diamond tools with Velcro are mounted on the foam plate 9"(Fig.5.4). The foam plate is mounted on the "QuickChange" System. Item number is LV-9-FP-S

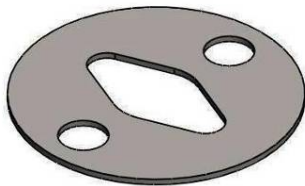

Figure 5.5

SECURITY PLATE FOR QUICKCHANGE PADS

Plate (Fig.5.5) used to ensure the "QuickChange" pads. Item number is A38.00.01

6. POPULAR TOOLS

RECOMMENDED TOOLS

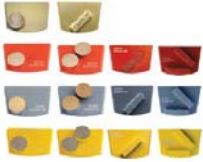

QuickChange System and Tooling feature extremely fast and convenient tool changes, and a long tool life, providing for great long-term cost savings. The QuickChange pads are produced in four different bonds for super hard, hard, medium and soft concrete, in a variety of grit sizes. They are offered with 1 or 2 buttons or rectangular segments, which allows you to customize the aggressiveness of the cut.

Calibra grinding discs: our popular ceramic bond discs are designed for the removal of difficult scratches and they save you valuable time by eliminating the need for multiple passes with metal tools. They can be used wet or dry, and are best for hard concrete applications. They are 3-inch, with included Velcro back attachment.



NATO® polishing discs feature a special resin formula designed for both wet and dry applications and a unique design with wide channels allowing for work on a cleaner surface and ensuring a quality polish. Available in 3 and 4 in sizes. They are with included Velcro attachment.



V-HARR® Premium Polishing Pads are designed for mechanically polishing and restoring concrete; also ideal for terrazzo and hard stone floors. V-HARR® pads are offered in a wide variety of diameters and grit sizes to accommodate many applications. Dry use is strongly recommended.



Shine Pro® are high quality diamond-impregnated pads for floor maintenance. Available in a variety of sizes, and are great for daily use. When used wet, they require only water (no wax or chemicals needed) and are a very environmentally friendly solution for maintaining floors.

Use only Superabrasive's recommended tools. For more tooling options, visit www.superabrasive.com

7. EXPLODED VIEW

LAVINA® 25L-S GENERAL EXPLODED VIEW (FIG.7.1)

LAVINA® 25L-S TOP COVER EXPLODED VIEW 1 (FIG.7.2)

LAVINA® 25L-S PLANETARY DRIVE EXPLODED VIEW (FIG.7.3)

LAVINA® 25L-S TOP COVER EXPLODED VIEW 2 (FIG.7.4)

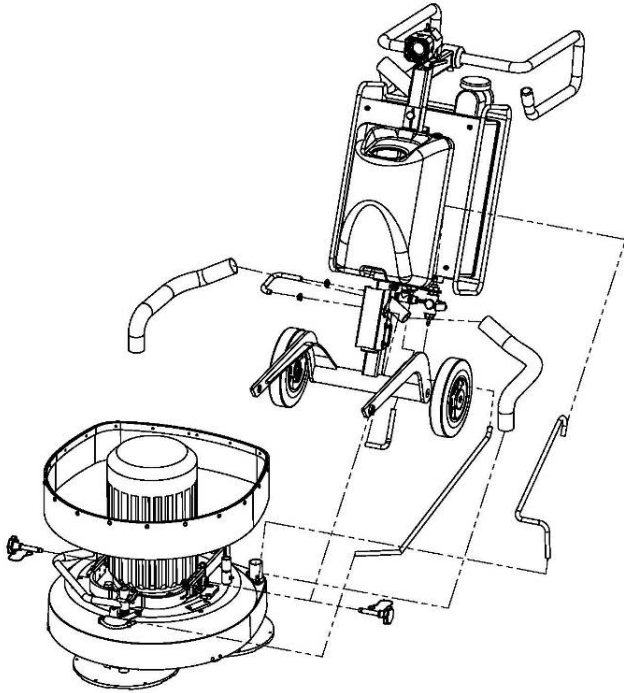

Figure 7.1

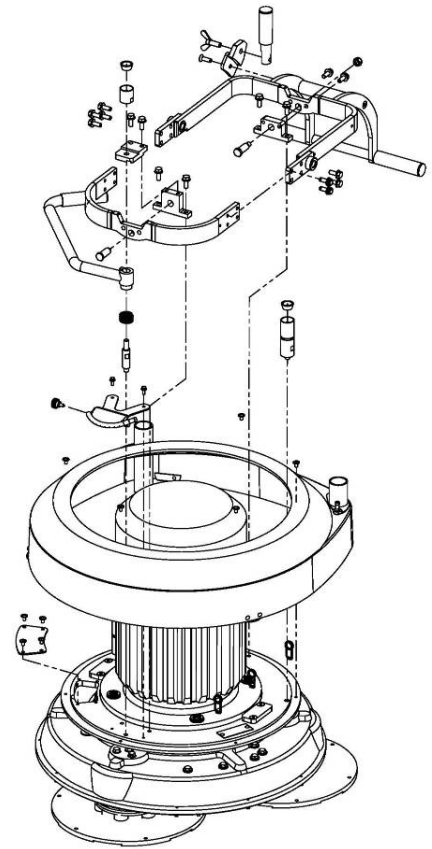

Figure 7.2

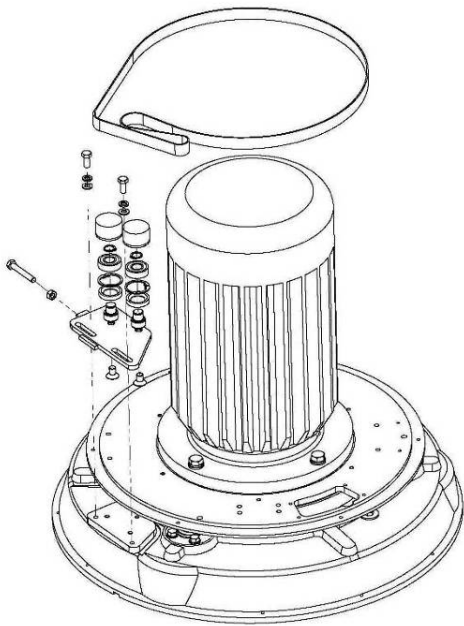

Figure 7.3

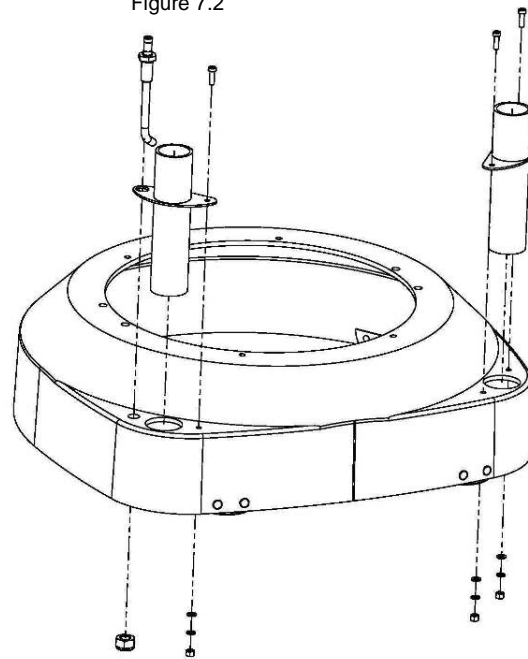

Figure 7.4

- LAVINA® 25L-S BOTTOM COVER EXPLODED VIEW 1 (FIG.7.5)
- LAVINA® 25L-S BOTTOM COVER EXPLODED VIEW 2 (FIG.7.6)
- LAVINA® 25L-S PULLEY UNITS EXPLODED VIEW (FIG.7.7)
- LAVINA® 25L-S CARRIAGE EXPLODED VIEW (FIG.7.8)
- LAVINA® 25L-S TOOL HOLDER EXPLODED VIEW (FIG.7.9)

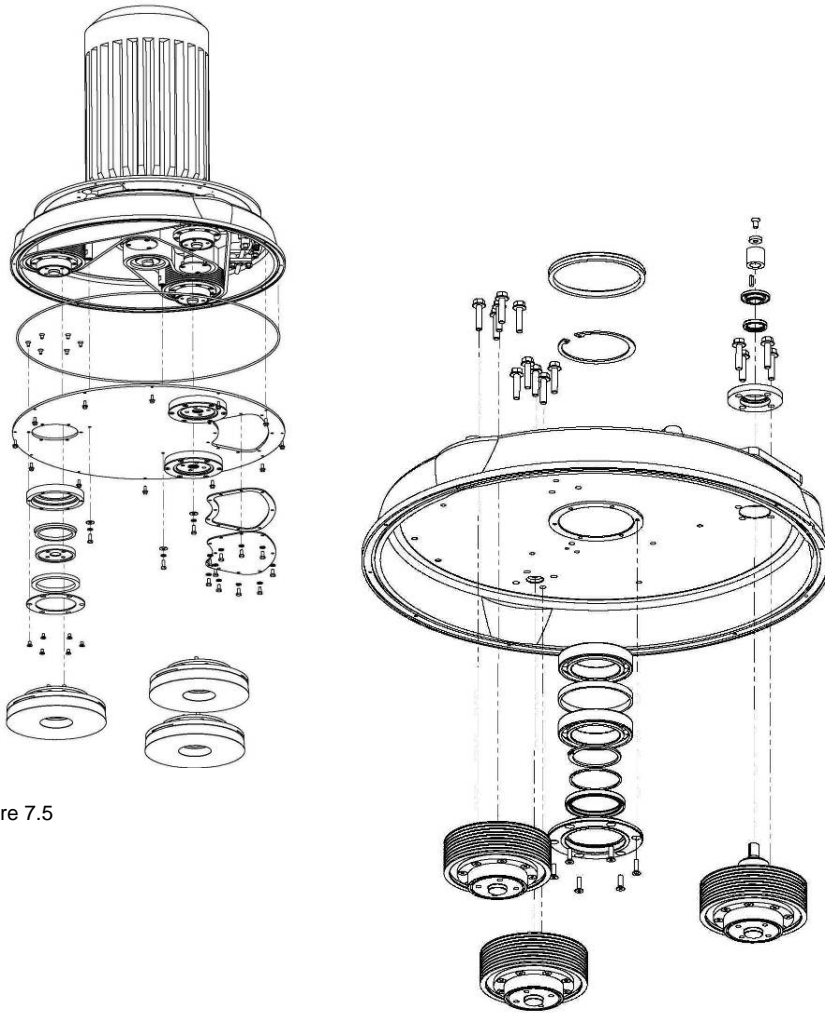

Figure 7.5

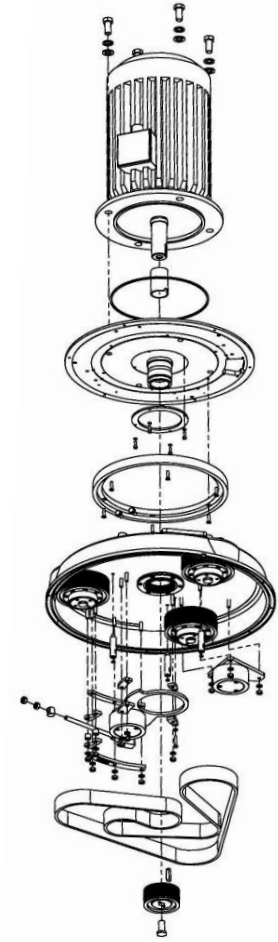

Figure 7.6

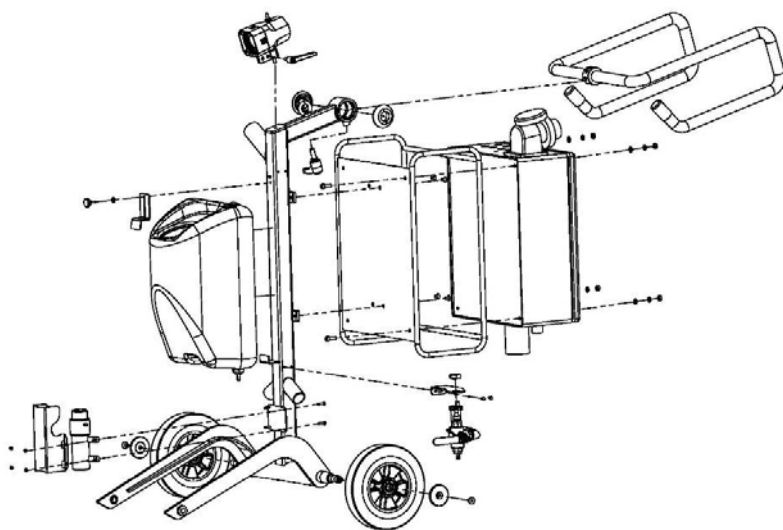

Figure 7.8

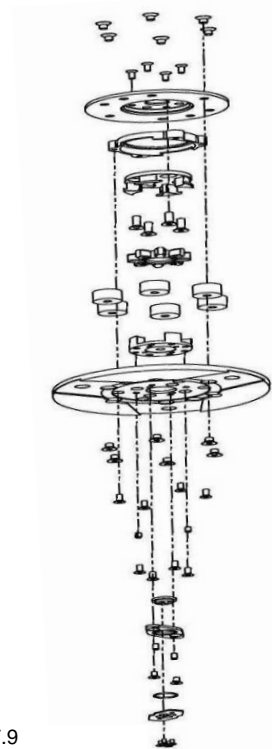

Figure 7.9

8. MAINTENANCE AND INSPECTION

CLEANING

Keep your machine clean. Cleaning the machine in a regular basis will help detect and solve potential problems before they can cause damage to the machine. Most importantly, check and clean the tool plate connections, power cords, plugs, vacuum hoses, and water tank.

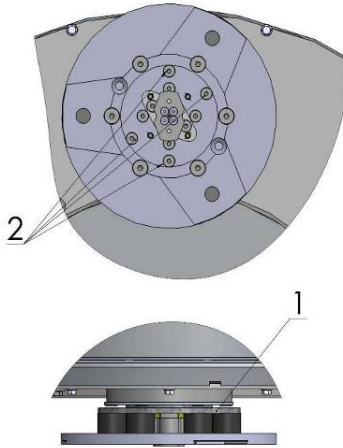

Figure 8.1

CHECK DAILY

After operating the Lavina® S machine, the operator should conduct a visual inspection of the machine. Any defect should be solved immediately. Pay attention to power cords, plugs, vacuum hoses, loose bolts or screws.

Tool holders: Buffers and spiders are consumables and must be visually checked on a daily basis and replaced if necessary. Make sure the flanges or discs are securely locked in place. The key lock holders (butterflies) should also be checked.

Check the rubber buffers and make sure the holders are secure. The flange holding the buffers (Fig.8.1-1) has to be firmly secured to the unit. If there is a gap seen here, that means the screws securing the holder are loose. The screws have to be tightened immediately to safely operate the machine. Working with loose screws could cause serious damage to the machine. The tightening force of the screws has to be 25-30N.m (18-22ft/lbs).

It is very important to regularly check the screws that secure the "QuickChange" holder to the safety part (Fig.8.1- 2), so that the holder will not fly away if the buffers get damaged. The "QuickChange" should be clean also. The tension of the planetary belt can be checked by moving the main head and feeling the resistance of the moving pulleys, tighten the belt if necessary.

CHECK AND REPLACE AFTER THE FIRST 15 WORKING HOURS

Check the belt tension after 15 hours of working with the machine. The bottom cover has a control cover (Fig.8.2) that allows fast and easy control and correction of the belt. It is recommended that the belt tension be checked after the first 15 hours and tightened if necessary. For the correct tension, see TROUBLESHOOTING "mounting the belt". Every time you open the control cover, mount back all the screws with washers.

CHECK EVERY 200 WORKING HOURS

Every 200 working hours, the operator should inspect all parts of the machine carefully. Most importantly, inspect and clean the tool plate connections, power cord plugs, vacuum hoses and water tank and filter. Also, check the water flow of the pump. Check the guard assembly. Make certain the wheels are clean and rotate properly. Inspect the control buttons. If there are defective control parts, they should be replaced immediately. Replace worn vacuum and water hoses. Check the tension of the belt and to tighten if necessary. For the correct tension, see TROUBLESHOOTING.

Dismount the tool holders (See TROUBLESHOOTING) and replace all parts (spider, buffers, sealer caps, "O" rings) that have the slightest damage.

Open the inspection cover on the motor base to check on the planetary driving belt, by moving the main head the belt should not slip on the planetary pulley and drive the pulleys.

CHECK EVERY 400 WORKING HOURS

Besides the checks of 200 working hours, replace sealer and V-rings like described in chapter "TROUBLESHOOTING REPLACING BELT AND PULLEY UNITS. Check if belts and bearings are in good condition, change if needed.

VACUUM

As stated previously, frequently check hoses and other parts for clogging.

WATER LEAKS

Leaking parts should be replaced immediately because the water could damage your machine.

MECHANICAL PARTS

Parts such as the belts, seal rings, cap rings, spiders, buffers and guard assembly are subject to wear and must be replaced as needed.

ELECTRICAL SYSTEM

Dust should not enter the control box, as it will destroy the controls. Remove (blow out) any dust present.

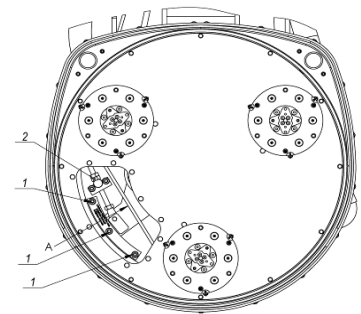
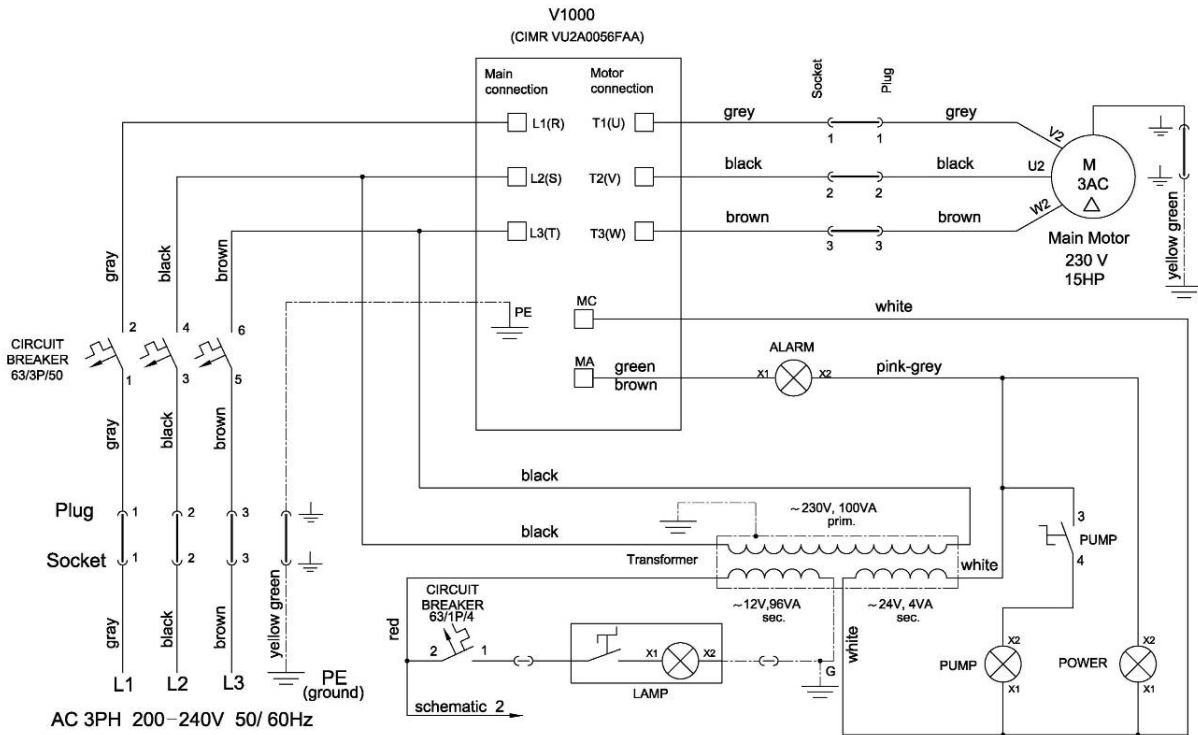

Figure 8.2

Lavina® 25L-S Electrical schemes with Yaskawa Inverter

200-240 Volt



LAVINA® 25L-S ELECTRICAL SCHEMES YASKAWA CONNECTION MAIN CIRCUIT TERMINALS

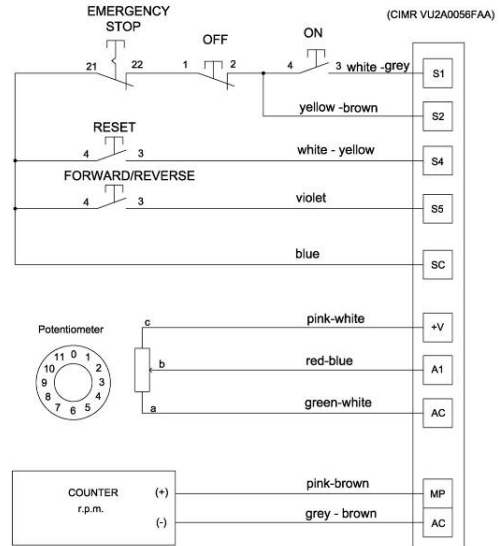
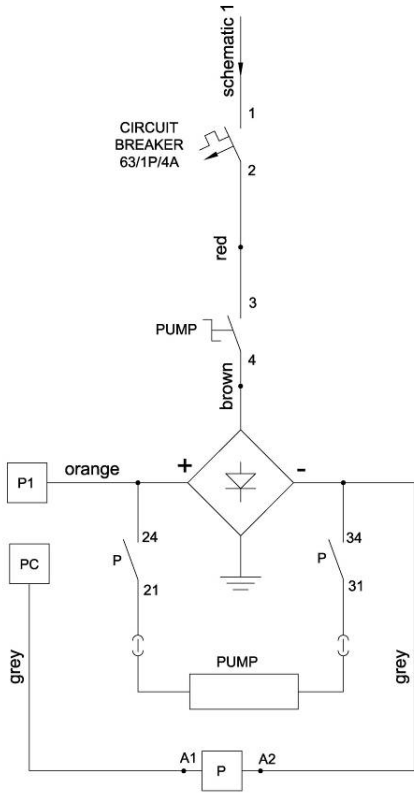

The motor is connected in "Delta" (triangle) 230 Volt, reminder for the wire connection of the motor.

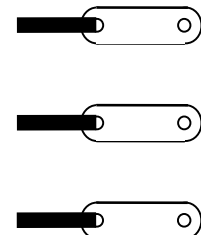

380-480 VOLT

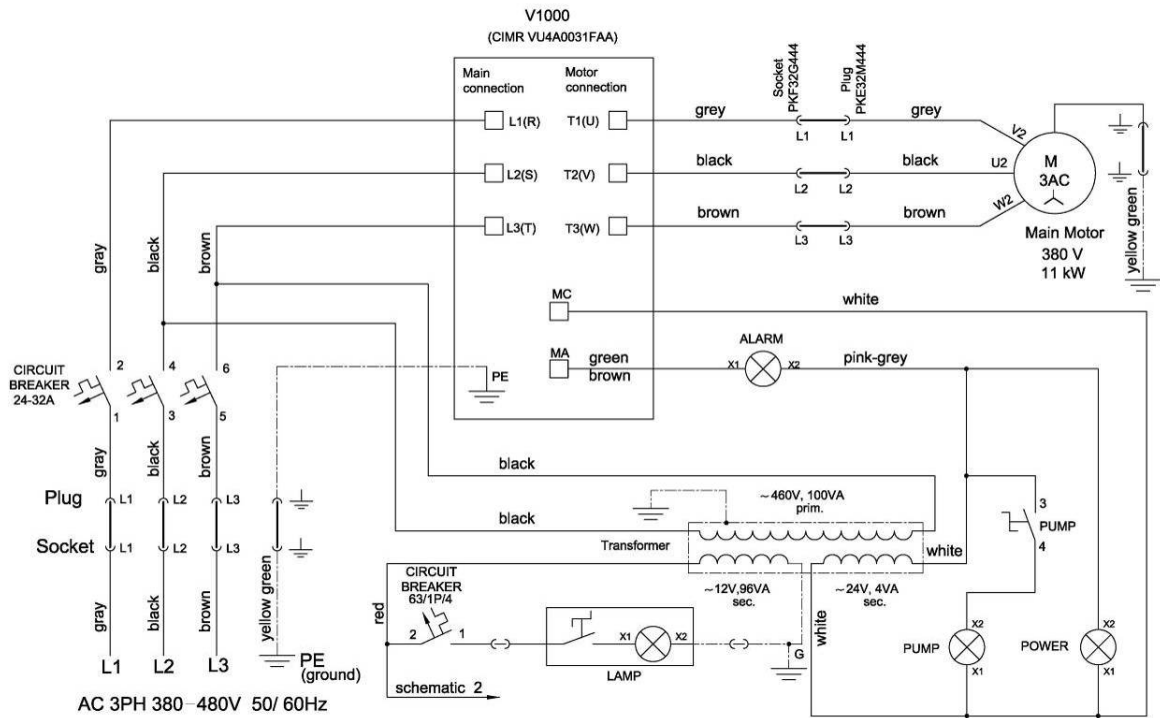

LAVINA® 25L-S-HV ELECTRICAL SCHEMES YASKAWA CONNECTION MAIN CIRCUIT TERMINALS

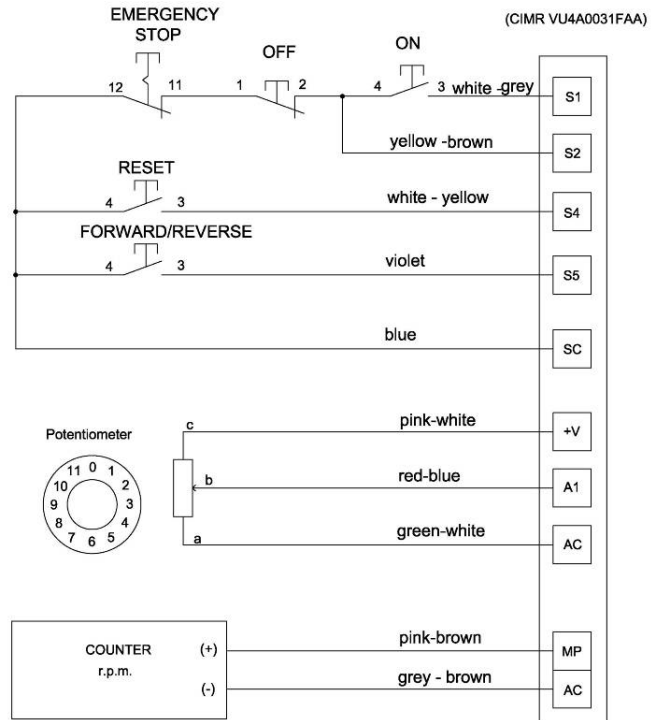
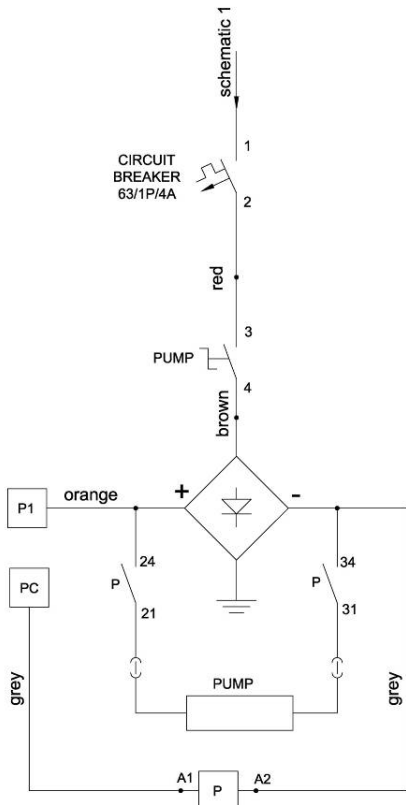

The motor is connected in "Star" 380 Volt, reminder for the wire connection of the motor

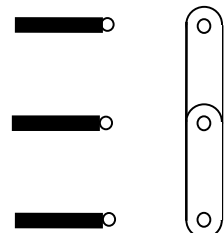

9. TROUBLESHOOTING

INDEX OF PROBLEMS AND SOLUTIONS

9.1 REPLACING POWER CORD AND PLUGS

When replacing the power cord or plugs always use cords and plugs with the same specifications as the original ones. Never use lower quality or different types of cords and plugs.

In addition, take into consideration the distance between the appliance and the electrical source. The greater the distance, the greater the resistance and the less current that will be available at the other end, there will be a voltage drop and the inverter will sign into alarm mode. This will also happen if several machines are working on the same line or when the generator is underrated. In general, our standard power cable can be doubled in length; if you need longer lengths then you must replace all the cables with cables of a bigger gauge rate for the length and amperage.

9.2 DISMOUNTING AND MOUNTING TOOL HOLDER TO CHANGE BUFFERS AND SPIDER, CHANGING V-RINGS AND FELT-RINGS



Figure 9.2.1



Figure 9.2.2



Figure 9.2.3



Figure 9.2.4

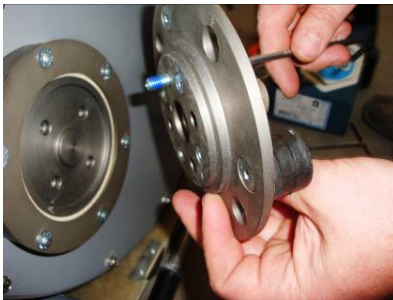

Figure 9.2.5



Figure 9.2.6

To check or replace the buffers and the spiders, the tool holder has to be removed. Remove the countersunk screws on top of the buffer (Fig.9.2.1). Take the disc off (Fig.9.2.2), now the spider can be removed or replaced (Fig.9.2.3). By loosening the four Hex cap bolts (Fig.9.2.4), the disc will come loose (Fig.9.2.5) and the buffers can be replaced (Fig.9.2.6). Attention, when mounting always use the “blue” thread locking adhesive, except on the bolts to lock the buffers (Fig.9.2.5). Always use the original bolts. Depending on the number (3, 4, or 6) of buffers, the holder can be more flexible or rigid.



Figure 9.2.7



Figure 9.2.8



Figure 9.2.9

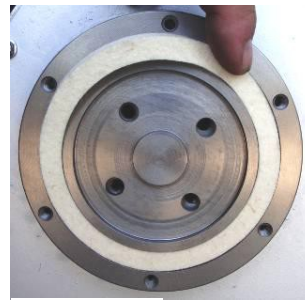

When the tool holder is removed, you can change the sealers (V-Ring and Felt-Ring). Take out the Felt-Ring, Adaptor and V-Ring. Before mounting check on which side the adaptor is sitting, remember the correct side. Mount the V-Ring with the smallest lip of the V to inside (Fig.9.2.7) just push the V-ring so the top is on the same level as the pulley top (Fig.9.2.8). Then take the adaptor in the correct way and push the V-Ring down with the adaptor (Fig.9.2.9). The lowest lip of the V-Ring should only barely touch its gliding surface; also never push the V-Ring down with fingers. Mount now the Felt-ring on top (Fig.9.2.10). Close the sealers with the cap (Fig.9.2.11).





Figure 9.3.1



Figure 9.3.2



Figure 9.3.3



Figure 9.3.4



Figure 9.3.5

If the belt slips or is broken separate the carriage from the main head, pull out the motor plug (Fig.9.3.1), water- (Fig.9.3.2) (Fig.9.3.3), and vacuum tubes (Fig.9.3.4). Take off the handles, fork, top frame, and weight holders so you can dismantle the top cover (Fig.9.3.5).

9.4 TENSIONING USED PLANETARY BELT



Figure 9.4.1



Figure 9.4.2

A noticeable loss of speed in the planetary movement means the belt may need to be tensioned, see 9.5 Mounting and tensioning a new planetary belt.

9.5 MOUNTING AND TENSIONING A NEW PLANETARY BELT



Figure 9.5.1



Figure 9.5.2



Figure 9.5.3



Figure 9.5.4

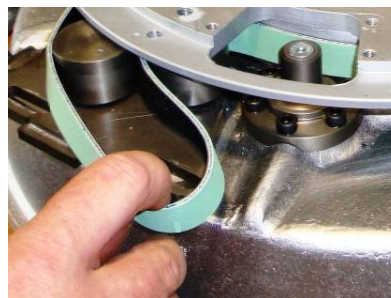

Figure 9.5.5



Figure 9.5.6



Figure 9.5.7



Figure 9.5.8



Figure 9.5.9

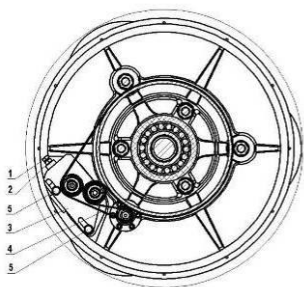

Completely remove the tensioning device (Fig. 9.5.1). Make 2 signs on the dismantled belt that are exactly 10cm from each other (belt without tension) (Fig.9.5.2). The purpose is to measure 10.2 cm on the belt when tensioned. **ATTENTION: NEVER “OVER” TENSION THE BELT, THE BELT WILL BE DAMAGED AND IT WILL NEVER RECOVER FROM ITS ORIGINAL TENSION** Mount the belt back around the planetary pulley; see that the belt is behind the driving pulley (Fig.9.5.3). Put the belt around the left roller of the tensioning device (Fig.9.5.4). Put the tensioning device back in place and pull the belt from the roller on the right side (Fig.9.5.5). Put the belt around the driving pulley (Fig.9.5.6). Begin to tension until the previous 10cm measurement equals 10.2cm (Fig.9.5.7 and Fig.9.5.8). Tighten the tensioning device while turning the bolt and moving the planetary head so the belt can slide (Fig. 9.5.8). Do not forget to lock the tensioning device (Fig.9.5.9).

9.6 CHECKING THE TENSION OF THE BELT



Figure 9.6.1



Figure 9.6.2



Figure 9.6.3



Figure 9.6.4



Figure 9.6.5

Open the checking cover to reach the belt and tension device (Fig.9.6.1). While tensioning, be sure to regularly check the tension. Push the belt down with a pressure of 71N. This is approximately 7 kilograms or 15 pounds; with this pressure the belt should move 3.5-4 mm or 1/8". It is recommended that the tensioning of the belt be measured with Optikrik II Device (Measuring range: 500-1400 N) (Fig.9.6.2). The original pressure P=1400 N and after working awhile is P=1100 N.

ATTENTION:NEVER “OVER” TENSION THE BELT, THE BELT WILL BE DESTROYED AND IT WILL NEVER RECOVER ITS ORIGINAL TENSION Loosen the contra nuts (Fig.9.6.3), lightly loosen the three bolts of the tension device (Fig.9.6.4), and adjust the tension with the nut seen in

(Fig.9.6.5). When the right tension is reached: close the contra nuts and the three bolts of the support. Reassemble in the same manner.

PLEASE MAKE SURE YOU CHECK THE TENSION OF THE BELT AFTER THE FIRST 15 HOURS OF OPERATION

9.7 REPLACING THE PULLEY UNITS

Dismount guard and top cover as previous described.



Figure 9.7.1



Figure 9.7.2



Figure 9.7.3



Figure 9.7.4



Figure 9.7.5



Figure 9.7.6



Figure 9.7.7



Figure 9.7.8



Figure 9.7.9



Figure 9.7.10



Figure 9.7.11



Figure 9.7.12

Dismounting the driving pulley: take the top screw out to release the bushing (Fig.9.7.1), push the bushing together with the washer up (Fig.9.7.2), push washer down of the bushing (Fig.9.7.3), take bushing out (Fig.9.7.4), push key out (Fig.9.7.5), now the washer releases (Fig.9.7.6), dismount sealer cap (Fig.9.7.7)(Fig.9.7.8), the pulley can be released with two crowbars but do not use excessive force (Fig.9.7.9), push the sealer cap to dismount (Fig.9.7.10), by mounting back secure with sealant (Fig.9.7.11), center the holes to mount the pulley (Fig.9.7.12).



Figure 9.7.13



Figure 9.7.14



Figure 9.7.15

For the two other pulleys, loose the five bolts of each pulley between the base plate and the motor base disc (Fig.9.7.13). An oil seal ring (Fig.9.7.14) and a seal (Fig.9.7.15) should be placed on top of the pulley before mounting.

9.8 MOUNTING THE BELT

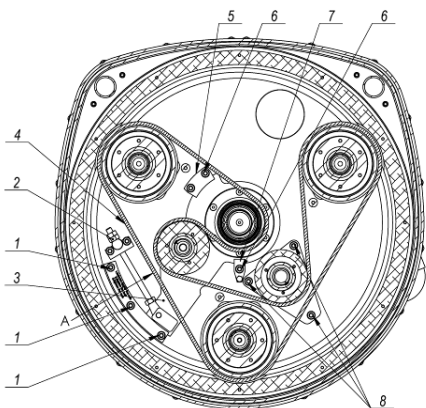

Figure 9.8.1

See here the schematic of the belt on the pulleys (Fig.9.8.1).

To dismount/mount the belt, follow the tensioning instruction in chapter: Checking the tension of the belt.

9.9 MOTOR CONNECTION

In case the motor is being replaced, please follow the cable connections in the figures below (Fig.9.9.1 and Fig.9.9.2).

Lavina® 25L- S

The motor is connected in "Delta" (Triangle) 230 Volt, reminder for the wire connection of the motor.

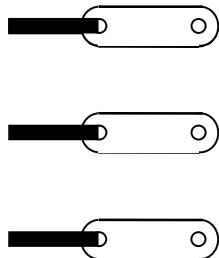

Figure 9.9.1

Lavina® 25L-S-HV

The motor is connected in "Star" 380 Volt, reminder for the wire connection of the motor.

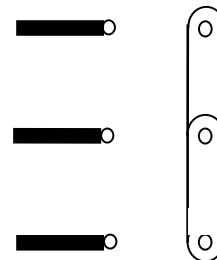

Figure 9.9.2

9.10 FAULT DIAGNOSIS INVERTER YASKAWA V1000

Pages are referring to

Yaskawa Electric SIEP C710606 18A YASKAWA AC Drive – V1000 Technical Manual

◆ Types of Alarms, Faults, and Errors

Check the LED operator for information about possible faults if the drive or motor fails to operate. *Refer to Using the Digital LED Operator on page 70.*

If problems occur that are not covered in this manual, contact the nearest Yaskawa representative with the following information:

- Drive model
- Software version
- Date of purchase
- Description of the problem

Table 6.4 contains descriptions of the various types of alarms, faults, and errors that may occur while operating the drive.

Contact Yaskawa in the event of drive failure.

Table 6.4 Types of Alarms, Faults, and Errors

Type	Drive Responses to Alarms, Faults, and Errors
Faults	<p>When the drive detects a fault:</p> <ul style="list-style-type: none"> • The digital operator displays text that indicates the specific fault and the ALM indicator LED remains lit until the fault is reset. • The fault interrupts drive output and the motor coasts to a stop. • Depending on the setting, the drive and motor may stop via different methods than listed. • If a digital output is programmed for fault output (H2-□□ = E), it will close if a fault occurs. • When the drive detects a fault, it will remain inoperable until that fault has been reset. <i>Refer to Fault Reset Methods on page 264.</i>
Minor Faults and Alarms	<p>When the drive detects an alarm or a minor fault:</p> <ul style="list-style-type: none"> • The digital operator displays text that indicates the specific alarm or minor fault and the ALM indicator LED flashes. • The motor does not stop. • One of the multi-function contact outputs closes if set to be tripped by a minor fault (H2-□□ = 10), but not by an alarm. • The digital operator displays text indicating a specific alarm and ALM indicator LED flashes. • Remove the cause of an alarm or minor fault to automatically reset.
Operation Errors	<p>When parameter settings conflict with one another or do not match hardware settings (such as with an option card), it results in an operation error.</p> <p>When the drive detects an operation error:</p> <ul style="list-style-type: none"> • The digital operator displays text that indicates the specific error. • Multi-function contact outputs do not operate. • When the drive detects an operation error, it will not operate the motor until the error has been reset. Correct the settings that caused the operation error to reset.
Tuning Errors	<p>Tuning errors occur while performing Auto-Tuning.</p> <p>When the drive detects a tuning error:</p> <ul style="list-style-type: none"> • The digital operator displays text indicating the specific error. • Multi-function contact outputs do not operate. • Motor coasts to stop. • Remove the cause of the error and repeat the Auto-Tuning process.

◆ Alarm and Error Displays

■ Faults

When the drive detects a fault, the ALM indicator LEDs remain lit without flashing. If the LEDs flash, the drive has detected a minor fault or alarm. *Refer to Minor Faults and Alarms on page 240* for more information. An overvoltage situation trips both faults and minor faults, therefore it is important to note whether the LEDs remain lit or if the LEDs flash.

LED Operator Display	Name	Page	LED Operator Display	Name	Page
bUS	bUS Option Communication Error	242	CPF08	EEPROM Serial Communications Fault	243
CE	MEMOBUS/Modbus Communication Error	242	CPF11	RAM Fault	243
CF	Control Fault	242	CPF12	FLASH Memory Fault	243
CoF	Current Offset Fault	242	CPF13	Watchdog Circuit Exception	243
CPF02	A/D Conversion Error	242	CPF14	Control Circuit Fault	243
CPF03	PWM Data Fault	243	CPF16	Clock Fault	243
CPF06	Drive specification mismatch during Terminal Board or Control Board replacement	243	CPF17	Timing Fault	243
CPF07	Terminal Board Communication Fault	243	CPF18	Control Circuit Fault	243
			CPF19	Control Circuit Fault	244

LED Operator Display		Name	Page	LED Operator Display		Name	Page
CPF20 or CPF21	CPF20or CPF21	RAM Fault	244	GF	GF	Ground Fault	245
		FLASH Memory Fault	244	LF	LF	Output Phase Loss	245
		Watchdog Circuit Exception	244	LF2	LF2	Output Open Phase	246
		Clock Fault	244	oC	oC	Overcurrent	246
oH3	oH3	Motor Overheat 1 (PTC input)	247	oFA00	oFA00	Option Card Fault (port A)	246
oH4	oH4	Motor Overheat 2 (PTC input)	248	oH	oH	Heatsink Overheat	247
oL1	oL1	Motor Overload	248	oH1	oH1	Heatsink Overheat	247
oL2	oL2	Drive Overload	248	PGo	PGo	PG Disconnect (for Simple V/f with PG)	250
oL3	oL3	Overtorque Detection 1	249	rH	rH	Dynamic Braking Resistor	251
oL4	oL4	Overtorque Detection 2	249	rr	rr	Dynamic Braking Transistor	251
oL5	oL5	Mechanical Weakening Detection 1	249	SEr	SEr	Too Many Speed Search Restarts	251
oL7	oL7	High Slip Braking oL	249	STO	STO	Pull-Out Detection	251
oPr	oPr	Operator Connection Fault	249	UL3	UL3	Undertorque Detection 1	251
CPF22	CPF22	A/D Conversion Error	244	UL4	UL4	Undertorque Detection 2	251
CPF23	CPF23	PWM Feedback Data Fault	244	UL5	UL5	Mechanical Weakening Detection 2	251
CPF24	CPF24	Drive Capacity Signal Fault	244	Uv1	Uv1	Undervoltage	252
dEv	dEv	Excessive Speed Deviation (for Simple V/f with PG)	244	Uv2	Uv2	Control Power Supply Undervoltage	252
EF0	EF0	Option Card External Fault	244	Uv3	Uv3	Soft Charge Circuit Fault	252
EF1 to EF7	EF1 to EF7	External Fault (input terminal S1 to S7)	244	oS	oS	Overspeed (for Simple V/f with PG)	249
FbH	FbH	Excessive PID Feedback	245	ov	ov	Overvoltage	249
FbL	FbL	PID Feedback Loss	245	PF	PF	Input Phase Loss	250

Note: If faults CPF11 through CPF19 occur, the LED operator will display CPF00 or CPF11.

■ Minor Faults and Alarms

When a minor fault or alarm occurs, the ALM LED flashes and the text display shows an alarm code. A fault has occurred if the text remains lit and does not flash. Refer to [Alarm Detection on page 253](#). An overvoltage situation, for example, can trigger both faults and minor faults. It is therefore important to note whether the LEDs remain lit or if the LEDs flash.

Table 6.5 Minor Fault and Alarm Displays

LED Operator Display		Name	Minor Fault Output (H2-□□ = 10)	Page
bb	bb	Drive Baseblock	No output	253
bUS	bUS	Option Card Communications Error	YES	253
CALL	CALL	Serial Communication Transmission Error	YES	253
CE	CE	MEMOBUS/Modbus Communication Error	YES	253
CrSt	CrSt	Can Not Reset	YES	253
dEv	dEv	Excessive Speed Deviation (for Simple V/f with PG)	YES	254
dnE	dnE	Drive Disabled	YES	254
EF	EF	Run Command Input Error	YES	254
EF0	EF0	Option Card External Fault	YES	254
EF1 to EF7	EF1 to EF7	External Fault (input terminal S1 to S7)	YES	255
FbH	FbH	Excessive PID Feedback	YES	255
FbL	FbL	PID Feedback Loss	YES	255
Hbb	Hbb	Safe Disable Signal Input	YES	255
HbbF	HbbF	Safe Disable Signal Input	YES	255
SE	SE	MEMOBUS/Modbus Test Mode Fault	YES	—
oL5	oL5	Mechanical Weakening Detection 1	YES	249
UL5	UL5	Mechanical Weakening Detection 2	YES	251
dWAL	dWAL	DriveWorksEZ Alarm	YES	244
HCA	HCA	Current Alarm	YES	256
oH	oH	Heatsink Overheat	YES	256
oH2	oH2	Drive Overheat	YES	256
oH3	oH3	Motor Overheat	YES	256
oL3	oL3	Overtorque 1	YES	256
oL4	oL4	Overtorque 2	YES	257
oS	oS	Overspeed (for Simple V/f with PG)	YES	257

LED Operator Display		Name	Minor Fault Output (H2-□□ = 10)	Page
<i>ou</i>	ov	Overvoltage	YES	257
<i>PASS</i>	PASS	MEMOBUS/Modbus Test Mode Complete	No output	257
<i>PGo</i>	PGo	PG Disconnect (for Simple V/f with PG)	YES	257
<i>rUn</i>	rUn	During Run 2, Motor Switch Command Input	YES	258
<i>rUnC</i>	rUnC	Run Command Reset	YES	258
<i>UL3</i>	UL3	Undertorque 1	YES	258
<i>UL4</i>	UL4	Undertorque 2	YES	258
<i>Uu</i>	Uv	Undervoltage	YES	258

■ Operation Errors

Table 6.6 Operation Error Displays

LED Operator Display		Name	Page	LED Operator Display		Name	Page
<i>oPE01</i>	oPE01	Drive Unit Setting Error	259	<i>oPE08</i>	oPE08	Parameter Selection Error	260
<i>oPE02</i>	oPE02	Parameter Setting Range Error	259	<i>oPE09</i>	oPE09	PID Control Selection Error	260
<i>oPE03</i>	oPE03	Multi-Function Input Setting Error	259	<i>oPE10</i>	oPE10	V/f Data Setting Error	261
<i>oPE04</i>	oPE04	Terminal Board Mismatch Error	260	<i>oPE11</i>	oPE11	Carrier Frequency Setting Error	261
<i>oPE05</i>	oPE05	Run Command Selection Error	260	<i>oPE13</i>	oPE13	Pulse Train Monitor Selection Error	261
<i>oPE07</i>	oPE07	Multi-Function Analog Input Selection Error	260				

10. DISPOSAL

If your machine after time is not usable or needs to be replaced, send the machine back to Superabrasive or a local distributor, where a professional disposal complying with the environment laws and directives is guaranteed.

11. MANUFACTURER'S CONTACTS

If you need to contact Superabrasive Inc. with technical support questions, below is the contact information. Address: 9411 Jackson Trail Road, Hoschton GA 30548, USA

Email: info@superabrasive.us

Tel.: 706 658 1122

Fax: 706 658 0357

Website: www.superabrasive.com

12. SPARE PARTS

ASSEMBLY AND PARTS SPECIFICATIONS

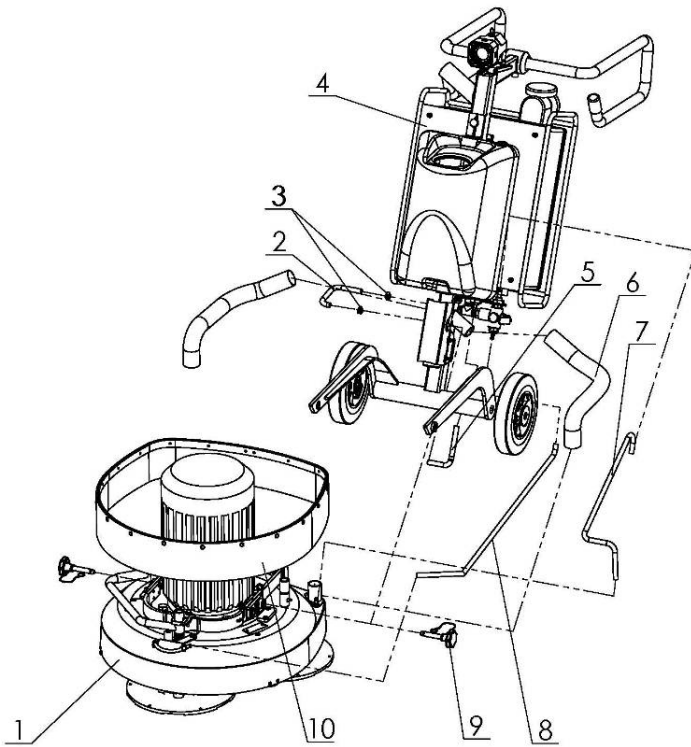

1. LAVINA®25L-S GENERAL PARTS				
/FOR MACHINES PRODUCED BEFORE JAN.1 2014/				
Model	No.	Item No.	Description	Pcs.
L25L-S	1	L25LS-10.00.00	Main Head	1
L25L-S	2	MAR8.25	Tube	1
L25L-S	3	10-16DIN3017	Clamp	2
L25L-S	4	L25LS-20.00.00	Carriage	1
L25L-S	5	MAR8.20	Tube	1
L25L-S	6	D40L670	Vacuum Hose	2
L25L-S	7	MAR8.84	Tube	1
L25L-S	8	MAR8.110	Tube	1
L25L-S	9	L25GS-03.00.00	Pin Assembly	2
L25L-S	10	L25SPS-05.00.00.00	Guard Assembly	1

1. LAVINA®25L-S GENERAL PARTS				
/FOR MACHINES PRODUCED AFRTER JAN.1 2014/				
Model	No.	Item No.	Description	Pcs.
L25L-S	1	L25LS-10.00.00-01	Main Head	1
L25L-S	2	MAR8.71	Tube	1
L25L-S	3	10-16DIN3017	Clamp	2
L25L-S	4	L25LS-20.00.00-01	Carriage	1
L25L-S	5	MAR8.25	Tube	1
L25L-S	6	D40L670	Vacuum Hose	2
L25L-S	7	MAR8.85	Tube	2
L25L-S	8	MAR8.110	Tube	1
L25L-S	9	L25GS-03.00.00	Pin Assembly	2
L25L-S	10	L25SPS-05.00.00.00	Guard Assembly	1

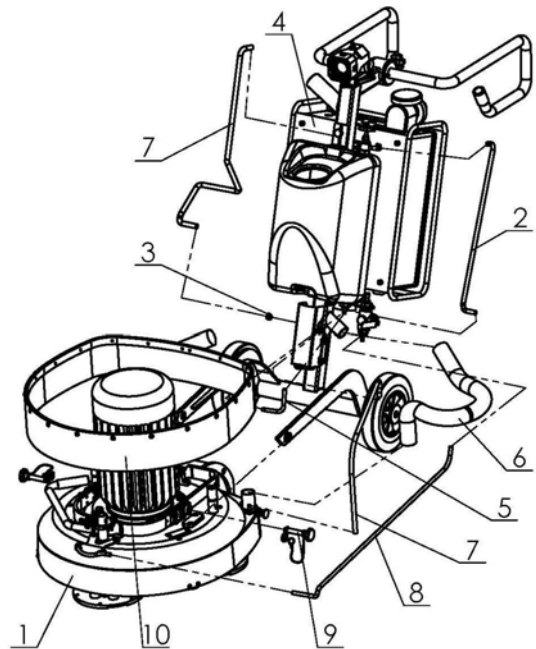

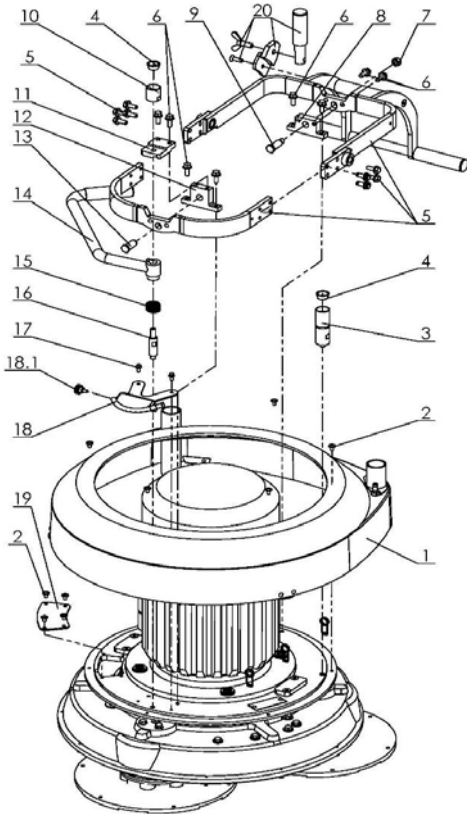

2.LAVINA®25L-S TOP COVER PARTS 1

/FOR MACHINES PRODUCED BEFORE JAN.1 2014/

Model	No.	Item No.	Description	Pcs.
L25L-S	1	L25GS-19.00.00	Top Cover Assembly	1
L25L-S	2	M6X10ISO7380F	Screw	10
L25L-S	3	L25NSPS-07.00.00.05	Back Weight Holder	2
L25L-S	4	L25SPS-07.00.00.29	Rubber Buffer	3
L25L-S	5	L25GS-18.00.00	Frame Assembly	1
L25L-S	6	M8X20DIN6921	Bolt	8
L25L-S	7	M10DIN982	Nut	1
L25L-S	8	L25GS-15.00.03	Support Back	1
L25L-S	9	L25GS-10.00.31	Pin Back	1
L25L-S	10	L25NP-07.00.00.10	Cup	1
L25L-S	11	L25GS-15.00.04	Support Top	1
L25L-S	12	L25GS-15.00.02	Support Front	1
L25L-S	13	L25GS-10.00.30	Pin Front	1
L25L-S	14	L25GS-15.02.00	Bar	1
L25L-S	15	L25SPS-07.00.00.25	Spring	1
L25L-S	16	L25SPS-07.00.00.26	Stud	1
L25L-S	17	M5X12DIN6921	Bolt	2
L25L-S	18	A29.10.00	Spray Unit	1
L25L-S	18.1	H766-21	Knob Bolt	1
L25L-S	19	L25S-15.00.23	Inspection Cover	1
L25L-S	20	L25GS-18.30.00	Clamp head	1

2. LAVINA®25L-S TOP COVER PARTS 1

/FOR MACHINES PRODUCED AFTER JAN.1 2014/

Model	No.	Item No.	Description	Pcs.
L25L-S	1	L25GS-19.00.00	Top Cover Assembly	1
L25L-S	2	M6X10ISO7380F	Screw	10
L25L-S	3	L25NSPS-07.00.00.05	Back Weight Holder	2
L25L-S	4	L25SPS-07.00.00.29	Rubber Buffer	3
L25L-S	5	L25GS-18.00.00	Frame Assembly	1
L25L-S	6	M8X20DIN6921	Bolt	8
L25L-S	7	M10DIN982	Nut	1
L25L-S	8	L25GS-15.00.03	Support Back	1
L25L-S	9	L25GS-10.00.31	Pin Back	1
L25L-S	10	L25NP-07.00.00.10	Cup	1
L25L-S	11	L25S-15.00.04	Support Top L25-S	1
L25L-S	12	L25GS-15.00.02	Support Front	1
L25L-S	13	L25GS-10.00.30	Pin Front	1
L25L-S	14	L25S-15.10.00	Bar Assembly L25-S	1
L25L-S	15.1	L25S-15.10.03	Spring L25-S	1
L25L-S	15.2	L25S-15.10.02	Lever	1
L25L-S	16	L25SPS-07.00.00.26	Stud	1
L25L-S	17	M5X12DIN6921	Bolt	2
L25L-S	18	A29.10.00	Spray Unit	1
L25L-S	18.1	H766-21	Knob Bolt	1
L25L-S	19	L25S-15.00.23	Inspection Cover	1
L25L-S	20	L25GS-18.30.00	Clamp head	1

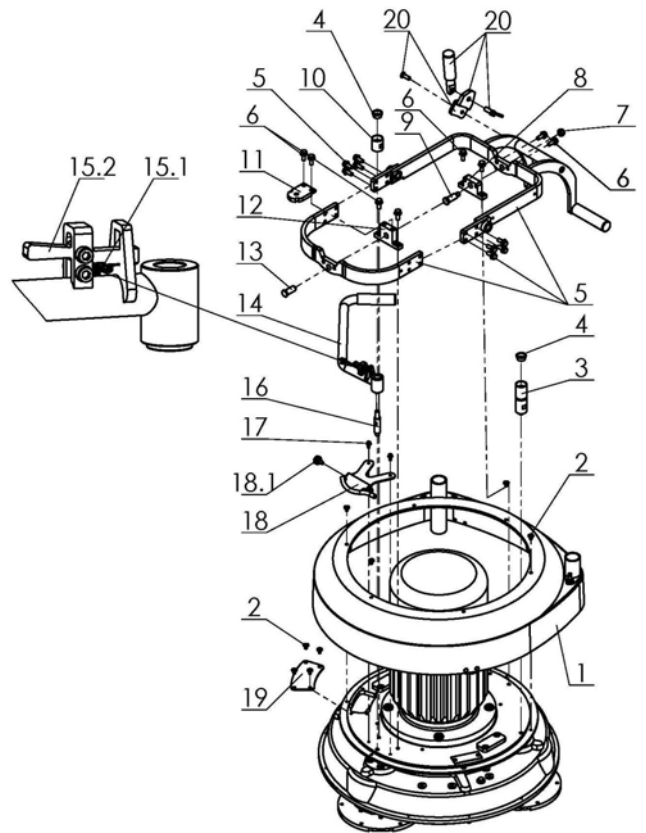

3. LAVINA®25L-S TOP COVER PARTS 2				
Model	No.	Item No.	Description	Pcs.
L25L-S	1	L25GS-19.00.01	Top Cover	1
L25L-S	2	L25GS-19.10.00	Vacuum Port	1
L25L-S	3	L25GS-19.20.00	Water Fitting	1
L25L-S	4	M12DIN985	Nut	1
L25L-S	5	M5DIN125A	Washer	3
L25L-S	6	M5DIN127B	Spring Washer	3
L25L-S	7	M5DIN934	Nut	3
L25L-S	8	L25SPS-04.01.00.00	Vacuum Port	1
L25L-S	9	M5X16DIN84A	Screw	3

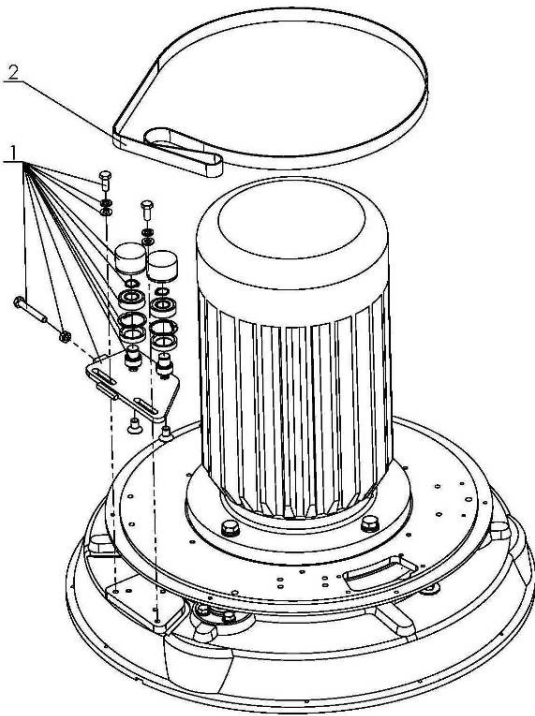
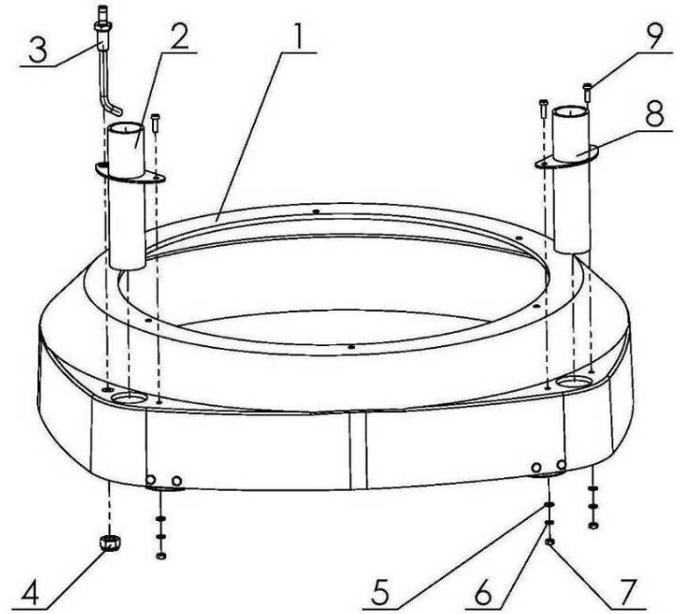

4. LAVINA®25L-S PLANETARY DRIVE PARTS				
Model	No.	Item No.	Description	Pcs.
L25L-S	1	L25S-17.00.00	Planetary Tensioning Unit	1
L25L-S	2	TC-20EF1500X20X2	Endless Transmission Flat Belt	1

5. LAVINA®25L-S GUARD PARTS				
Model	No.	Item No.	Description	Pcs.
L25L-S	1	D4X10DIN7337	Rivet	19
L25L-S	2	M4DIN9021A	Washer	19
L25L-S	3	L25SPS-05.00.00.01	Ring	1
L25L-S	4	L25SPS-05.00.00.02	Guard	1

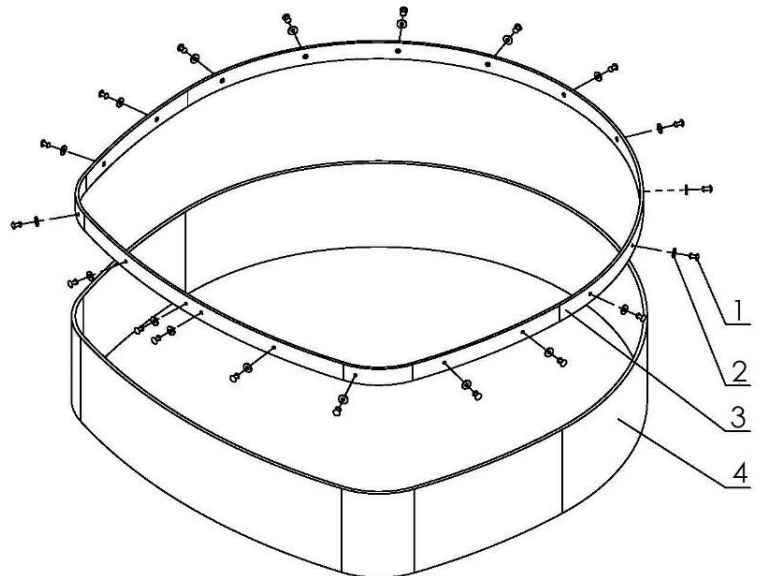

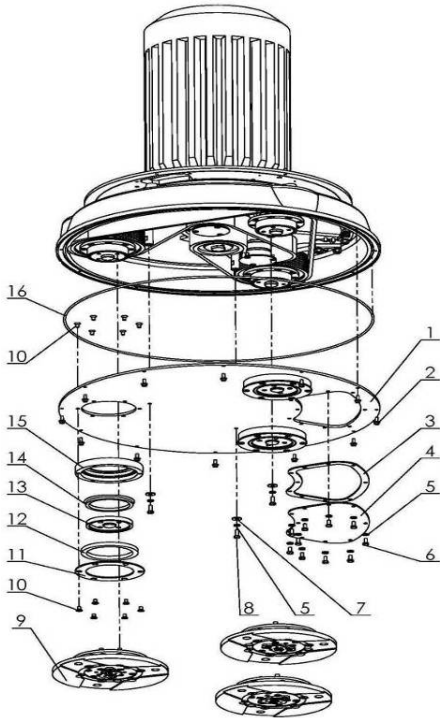

6. LAVINA®25L-S BOTTOM COVER PARTS 1				
Model	No.	Item No.	Description	Pcs.
L25L-S	1	L25LS-14.00.00	Bottom Cover Assembly	1
L25L-S	2	M5X12DIN6921	Bolt	12
L25L-S	3	L25LS-14.00.05	Sealer Inspection Cover	1
L25L-S	4	L25L-10.00.09	Inspection Cover	1
L25L-S	5	M6DIN127B	Spring Washer	13
L25L-S	6	M6X12DIN933	Bolt	10
L25L-S	7	M6DIN9021	Washer	3
L25L-S	8	M6X16DIN933	Bolt	3
L25L-S	9	A31.00.00	Tool Holder A31	3
L25L-S	10	M6X10DIN7991	Screw	36
L25L-S	11	L25LS-14.00.03	Outer Cover	3
L25L-S	12	110X90X8.5	Felt Ring	3
L25L-S	13	A37.00.01	Adaptor	3
L25L-S	14	TWVA00800	V-Ring Type A	3
L25L-S	15	L25LS-14.00.02	Flange	3
L25L-S	16	D4X2X2000	Seal	1

7. LAVINA®25L-S BOTTOM COVER PARTS 2				
Model	No.	Item No.	Description	Pcs.
L25L-S	1	S253	Electro Motor	1
L25L-S	2	M16DIN125A	Washer	4
L25L-S	3	M16DIN127B	Spring Washer	4
L25L-S	4	M16X35DIN933	Bolt	4
L25L-S	5	L25L-10.00.26	Main space bushing	1
L25L-S	6	D4X2X850	Seal	1
L25L-S	7	L25LS-15.01.00	Base Plate	1
L25L-S	8	L25P-01.03.00.09	Flange	1
L25L-S	9	M5DIN7980	Spring Washer	4
L25L-S	10	M5X16DIN912	Screw	4
L25L-S	11	L25S-15.00.22	Planetary Pulley	1
L25L-S	12	M6X25DIN7991	Screw	6
L25L-S	13	L25L-13.00.00	Deflection Pulley	1
L25L-S	14	M8DIN127B	Spring Washer	11
L25L-S	15	M8DIN934	Nut	11
L25L-S	16	L25L-10.00.15	Sector	1
L25L-S	17	L25L-12.00.00	Tensioning Support	1
L25L-S	18	L25L-10.00.16	Sector	1
L25L-S	19	M6DIN127B	Spring Washer	1
L25L-S	20	M6X30DIN933	Bolt	1
L25L-S	21	PL2476-975L-9	Endless Transmission V Belt	1
L25L-S	22	DIN6885A12X8X36	Key	1
L25L-S	23	L25LS-10.01.00	Central Pulley	1
L25L-S	24	L25NSPS-00.00.00.14	Screw	1
L25L-S	25	L25L-10.00.14	Sector	1
L25L-S	26	L25L-10.00.07	Support	2
L25L-S	27	L25L-10.00.08	Washer	2
L25L-S	28	L32C-14.20.04	Nut	1
L25L-S	29	M10DIN934	Nut	2
L25L-S	30	L25L-10.00.12	Sector	1
L25L-S	31	L25L-10.00.13	Sector	1
L25L-S	32	L25L-10.00.11	Sector	1
L25L-S	33	L25L-10.00.19	Distance Bolt	3
L25L-S	34	D6X2	O-Ring	3

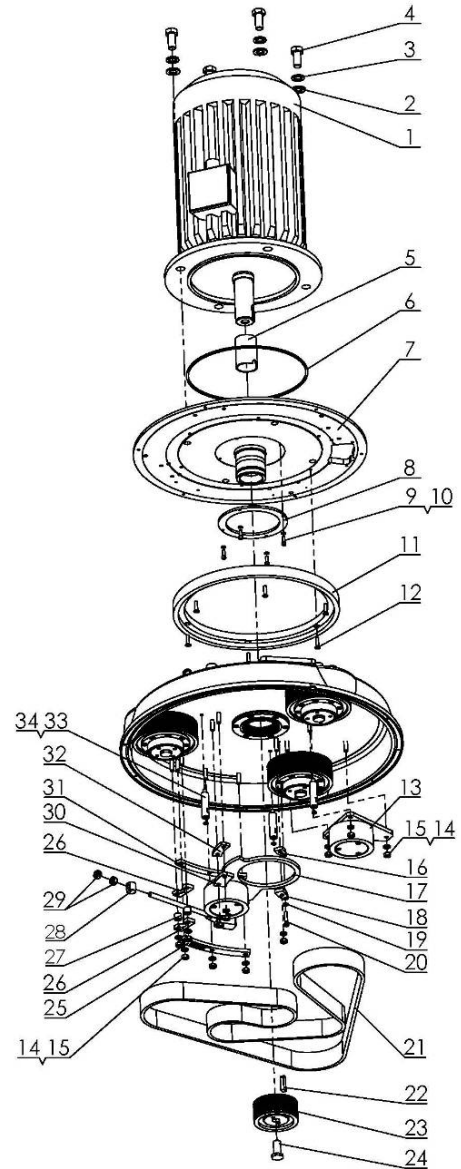

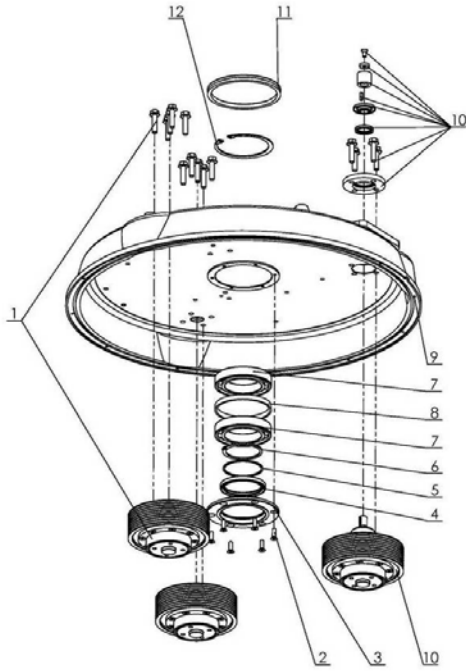

8. LAVINA®25L-S PULLEY UNIT PARTS				
Model	No.	Item No.	Description	Pcs.
L25L-S	1	L25LS-11.00.00	Pulley Unit Assembly	2
L25L-S	2	M6X20DIN7991	Screw	6
L25L-S	3	L25L-10.00.21	Cap	1
L25L-S	4	TRA000650	Rotary Seal	1
L25L-S	5	L25SPS-00.00.00.23	Compensating Ring	1
L25L-S	6	B65DIN471	Retaining Ring	1
L25L-S	7	6013	Roller Assembly	2
L25L-S	8	L25SPS-00.00.00.34	Distance Ring	1
L25L-S	9	L25LS-10.00.06	Disc	1
L25L-S	10	L25S-16.00.00	Driving Pulley Unit	1
L25L-S	11	TWVA01200	V-Ring Type A	1
L25L-S	12	A10013943	Retaining Ring	1

8a. LAVINA®25L-S PULLEY UNIT ASSEMBLY				
Model	No.	Item No.	Description	Pcs.
L25L-S	1	L25LS-16.00.03	Flange	1
L25L-S	2	M6X16DIN7991	Screw	8

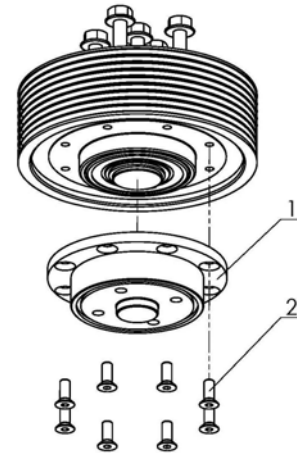
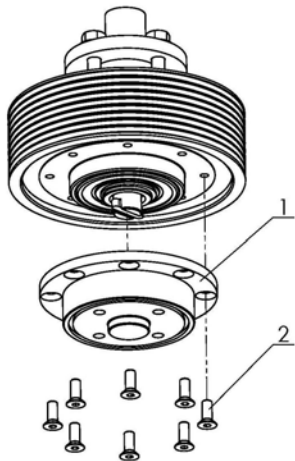

8b. LAVINA®25L-S DRIVING PULLEY UNIT				
Model	No.	Item No.	Description	Pcs.
L25L-S	1	L25LS-16.00.03	Flange	1
L25L-S	2	M6X16DIN7991	Screw	8

9. LAVINA®25L-S WATER SUPPLY PARTS /FOR MACHINES PRODUCED BEFORE JAN.1 2014/				
Model	No.	Item No.	Description	Pcs.
L25L-S	1	A29.21.00	Backflow Preventer	1
L25L-S	2	A29.22.00	Vent Valve	1

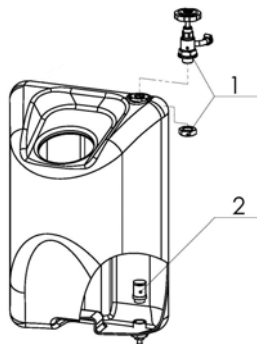
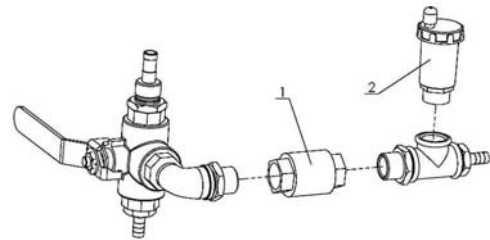

9. LAVINA®25L-S WATER TANK PARTS /FOR MACHINES PRODUCED AFTER JAN.1 2014/				
Model	No.	Item No.	Description	Pcs.
L25L-S	1	A29.50.00	Regulator	1
L25L-S	2	1/2"	Filter	1

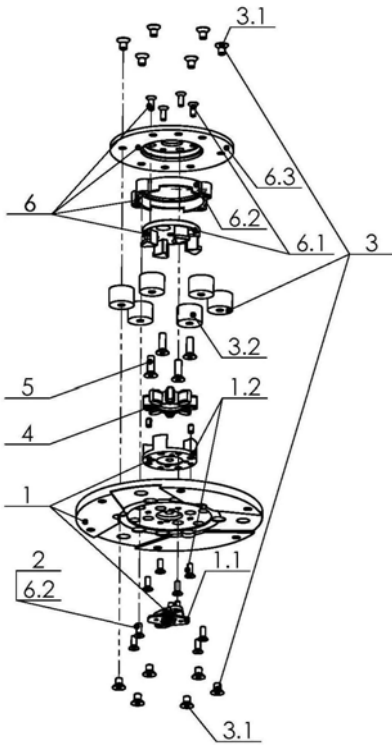

10. LAVINA®25L-S TOOL HOLDER PARTS				
Model	No.	Item No.	Description	Pcs.
25L-S	1	A31.10.00	Quick Change Assembly	1
25L-S	1.1	A31.12.00	Keylock Set	1
25L-S	1.2	A31.10.02-K	Copling 2 with screws	1
25L-S	2	M6X16DIN7991	Screw	4
25L-S	3	A25.00.10-K	Buffer with two screw	6
25L-S	3.1	M8X12DIN7991	Screw	12
25L-S	3.2	A25.00.10	Buffer	6
25L-S	4	A25.00.05-02	Spider	1
25L-S	5	M8X25DIN7991-10.9	Screw	4
25L-S	6	A31.20.00	Flange	1
25L-S	6.1	A31.20.03-K	Copling 1 with screws	1
25L-S	6.2	A31.20.02-K	Security ring	1
25L-S	6.3	A31.20.01	Flange A31	1

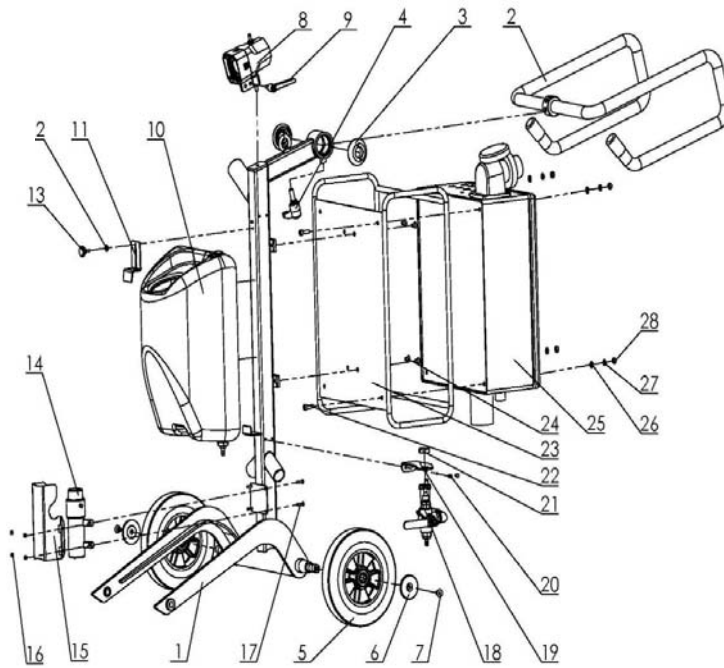

11. LAVINA®25L-S CARRIAGE PARTS/FOR MACHINES PRODUCED BEFORE JAN.1 2014/								
Model	No.	Item No.	Description	Pcs.	No.	Item No.	Description	Pcs.
L25L-S	1	L25LS-21.00.00	Frame	1	16	M5DIN985	Nut	4
L25L-S	2	L25G-23.00.00	Handle Assembly	1	17	M5X20DIN933	Bolt	4
L25L-S	3	L25SPS-02.00.00.18-01	Nut	2	18	A29.20.00	Water Flow Control Unit	1
L25L-S	4	A58194	Swivel Bolt	1	19	A29.20.01-01	Flow Unit Base	1
L25L-S	5	L25G-20.00.04	Wheel	2	20	M5X12DIN6921	Bolt	2
L25L-S	6	L32D-20.00.03	Wheel Cap	2	21	M20X1.5DIN439B	Nut	1
L25L-S	7	M10X16DIN7991	Screw	2	22	M8X25DIN912	Screw	4
L25L-S	8	L20NS-30.30.00	Lamp Unit Incl. Cable	1	23	L25S-22.00.00	Guard	1
L25L-S	9	A58165	Swivel Bolt	1	24	M8X12DIN7991	Screw	4
L25L-S	10	A33.00.00	Tank	1	25	L25LS-30.00.00	Control Box L25L-S	1
L25L-S	11	L25P-02.00.00.01	Top Bracket	1	25	L25LHVS-30.00.00	Control Box L25L-S-HV	1
L25L-S	12	M5UN732	Washer	1	26	M8DIN125A	Washer	4
L25L-S	13	T34391	Knob Bolt	1	27	M8DIN127B	Spring Washer	4
L25L-S	14	1040	Water Pump	1	28	M8DIN934	Nut	4
L25L-S	15	L25S-20.00.26	Guard	1				

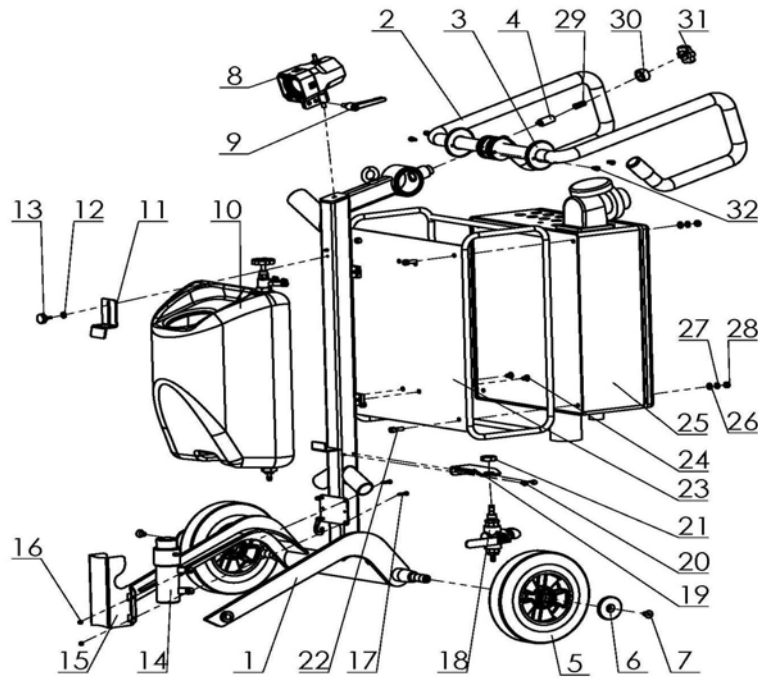

11. LAVINA®25L-S CARRIAGE PARTS/FOR MACHINES PRODUCED AFTER JAN.1 2014/								
Model	No.	Item No.	Description	Pcs.	No.	Item No.	Description	Pcs.
L25L-S	1	L25LS-21.00.00-01	Frame	1	17	M5X20DIN933	Bolt	4
L25L-S	2	L25S-23.10.00	Handle Assembly	1	18	A29.40.00	Water Flow Control Unit	1
L25L-S	3	L25S-23.00.02	End Cover	2	19	A29.20.01-01	Flow Unit Base	1
L25L-S	4	L25S-23.00.06	Locking bit	1	20	M5X12DIN6921	Bolt	2
L25L-S	5	L25G-20.00.04	Wheel	2	21	M20X1.5DIN439B	Nut	1
L25L-S	6	L32D-20.00.03	Wheel Cap	2	22	M8X25DIN912	Screw	4
L25L-S	7	M10X16DIN7991	Screw	2	23	L25S-22.00.00	Guard	1
L25L-S	8	L20NS-30.30.00	Lamp Unit Incl. Cable	1	24	M8X12DIN7991	Screw	4
L25L-S	9	A58165	Swivel Bolt	1	25	L25LS-30.00.00	Control Box L25L-S	1
L25L-S	10	A33.10.00	Tank Assembly	1	25	L25LHVS-30.00.00	Control Box L25L-S-HV	1
L25L-S	11	L25P-02.00.00.01	Top Bracket	1	26	M8DIN125A	Washer	4
L25L-S	12	M5UN732	Washer	1	27	M8DIN127B	Spring Washer	4
L25L-S	13	T34391	Knob Bolt	1	28	M8DIN934	Nut	4
L25L-S	14	1040	Water Pump	1	29	L25-S-23.00.07	Spring L25-S	1
L25L-S	15	L25S-20.00.26	Guard	1	30	L25-S-23.00.09	Nut	1
L25L-S	16	M5DIN985	Nut	4	31	F17840.TM08x40	Knob Bolt	1
L25L-S					32	M6X12DIN912	Screw	4

12. LAVINA® 25L-S CONTROL BOX PARTS 200-240 VOLT

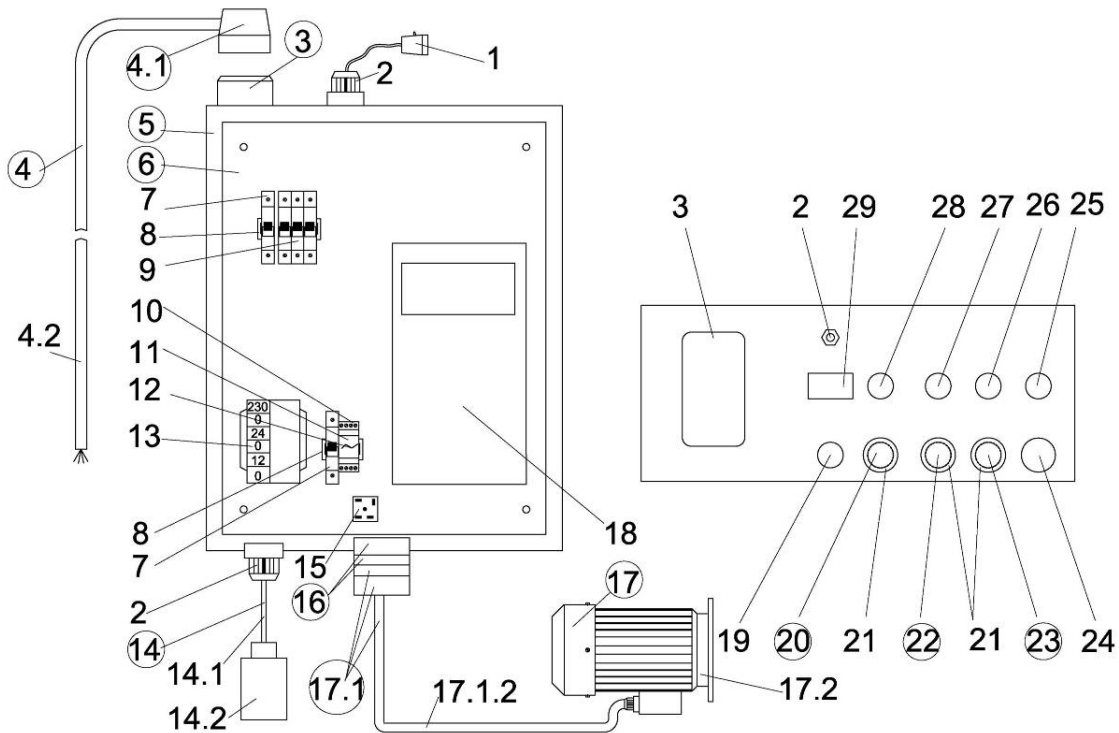

12. LAVINA®25L-S CONTROL BOX PARTS 200-240 VOLT

Model	No.	Item No.	Description	Pcs.	No.	Item No.	Description	Pcs.
L25L-S	1	L20NS-30.30.00	Lamp Unit Incl. Cable	1	15	L20NS-30.11.08	Rectifier	1
L25L-S	2	L20NS-30.10.01	Cable Gland	2	16	L25LS-30.50.00	Panel socket assembly	1
L25L-S	3	L25LS-30.30.10	Plug on Control Board	1	17	L25LS-30.20.00	Electro Motor Assembly	1
L25L-S	4	L25LS-30.02.00	Cable with Connector and Plug	1	17.1	L25LS-30.20.10	Plug with cable assembly	1
L25L-S	4.1	L25LS-30.02.10	Connector Ass.	1	17.1.2	L25S-30.20.12	Cable for Electro Motor	1
L25L-S	4.2	L25S-30.02.02	Cable	1	17.2	S253	Electro Motor	1
L25L-S	5	L25LS-30.10.00	Metal box	1	18	L25S-30.11.09	Inverter Yaskawa (V1000)	1
L25L-S	6	L25LS-30.11.00	Metal box plate	1	19	L20NS-30.10.04	Potentiometer	1
L25L-S	7	L20NS-30.11.01	Circuit Breaker	1	20	L20NS-30.10.05	Reset Button	1
L25L-S	8	L20NS-30.11.02	Rail	2	21	L20NS-30.10.06	Cap	3
L25L-S	9	L25LS-30.11.03	Circuit Breaker	1	22	L20NS-30.10.07	Off Button	1
L25L-S	10	L20NS-30.11.04	Rail Base	1	23	L20NS-30.10.08	On Button	1
L25L-S	11	L20NS-30.11.05	Rail	1	24	L20NS-30.10.10	Emergency Stop Button	1
L25L-S	12	L25NS-30.11.06	Rail Bracket	1	25	L20NS-30.10.11	Switch Button F/R	1
L25L-S	13	L20NS-30.11.07	Transformer	1	26	L20NS-30.10.12	Green LED Power	1
L25L-S	14	L20NS-30.40.00	Water Pump with Cable	1	27	L20NS-30.10.13	Water Pump Button	1
L25L-S	14.1	L20NS-30.40.01	Cable for Water Pump	1	28	L20NS-30.10.14	Blue Led Alarm	1
L25L-S	14.2	1040	Water Pump	1	29	L20NS-30.10.15	Revolution counter	1

13. LAVINA® 25L-S-HV CONTROL BOX PARTS 380-480 VOLT

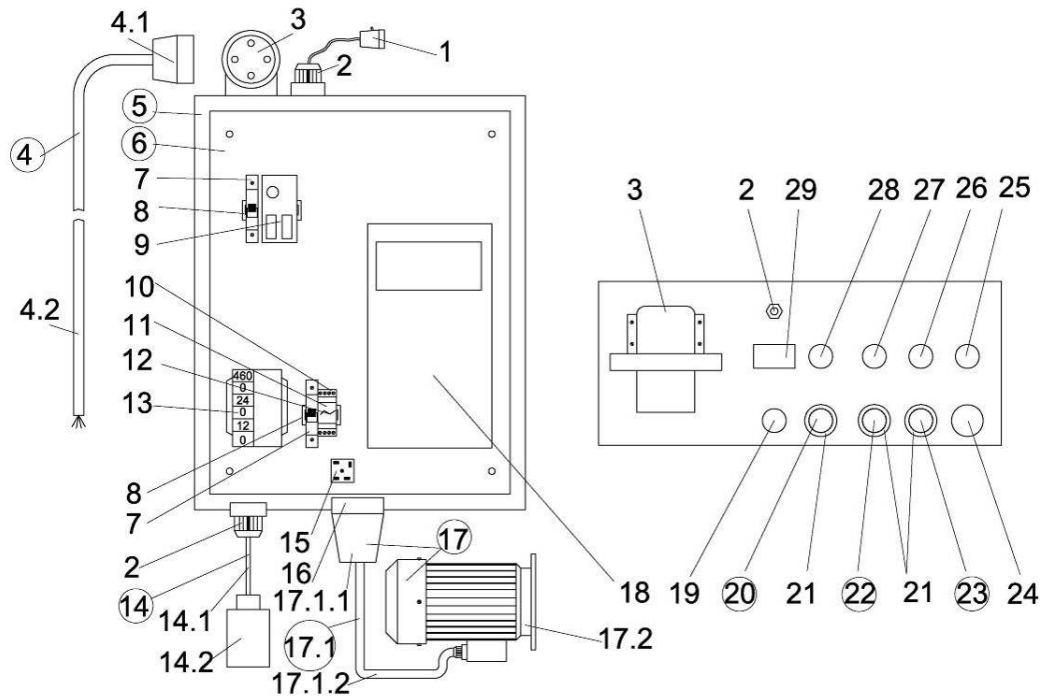

13. LAVINA®25L-S-HV CONTROL BOX PARTS 380-480 VOLT								
Model	No.	Item No.	Description	Pcs.	No.	Item No.	Description	Pcs.
L25L-S-HV	1	L20NS-30.30.00	Lamp Unit Incl. Cable	1	16	L25LHVS-30.10.03	Socket	1
L25L-S-HV	2	L20NS-30.10.01	Cable Gland	2	17	L25LHVS-30.20.00	Electro Motor Assembly	1
L25L-S-HV	3	L25LHVS-30.10.02	Plug on Control Board	1	17.1	L25LHVS-30.20.10	Plug with Cable	1
L25L-S-HV	4	L25LHVS-30.02.00	Cable with Connector	1	17.1.1	L25LHVS -30.20.11	Plug	1
L25L-S-HV	4.1	L25LHVS-30.02.04	Connector	1	17.1.2	L25LHVS -30.20.12	Cable for Electro Motor	1
L25L-S-HV	4.2	L25LHVS-30.02.02	Cable	1	17.2	S253	Electro Motor	1
L25L-S-HV	5	L25LHVS-30.10.00	Metal Box	1	18	L25HVS-30.11.09	Inverter Yaskawa (V1000)	1
L25L-S-HV	6	L25LHVS-30.11.00	Metal Box Plate	1	19	L20NS-30.10.04	Potentiometer	1
L25L-S-HV	7	L20NS-30.11.01	Circuit Breaker	2	20	L20NS-30.10.05	Reset Button	1
L25L-S-HV	8	L20NS-30.11.02	Rail	2	21	L20NS-30.10.06	Cap	3
L25L-S-HV	9	L25LHVS-30.11.03	Circuit Breaker	1	22	L20NS-30.10.07	Off Button	1
L25L-S-HV	10	L20NS-30.11.04	Rail Base	1	23	L20NS-30.10.08	On Button	1
L25L-S-HV	11	L20NS-30.11.05	Rail	1	24	L20NS-30.10.10	Emergency Stop Button	1
L25L-S-HV	12	L20NS-30.11.06	Rail Bracket	1	25	L20NS-30.10.11	Switch Button F/R	1
L25L-S-HV	13	L20NHVS-30.11.07	Transformer	1	26	L20NS-30.10.12	Green LED Power	1
L25L-S-HV	14	L20NS-30.40.00	Water Pump with Cable	1	27	L20NS-30.10.13	Water Pump Button	1
L25L-S-HV	14.1	L20NS-30.40.01	Cable for Water Pump	1	28	L20NS-30.10.14	Blue Led Alarm	1
L25L-S-HV	14.2	1040	Water Pump	1	29	L20NS-30.10.15	Revolution counter	1
L25L-S-HV	15	L20NS-30.11.08	Rectifier	1				