

**President's Reorganization Project—Decision Analysis Report,  
6/28/77**

Folder Citation: Collection: Office of the Chief of Staff Files; Series:  
Hamilton Jordan's Confidential Files; Folder: President's Reorganization  
Project—Decision Analysis Report, 6/28/77; Container 36

To See Complete Finding Aid:

[http://www.jimmycarterlibrary.gov/library/findingaids/Chief\\_of\\_Staff.pdf](http://www.jimmycarterlibrary.gov/library/findingaids/Chief_of_Staff.pdf)

WITHDRAWAL SHEET (PRESIDENTIAL LIBRARIES)

FORM OF DOCUMENT	CORRESPONDENTS OR TITLE	DATE	RESTRICTION
case studies	<del>E. Wiretap Legislation</del>	<del>6-28-77</del>	A
case studies	<del>F. Breeder Reactor Program</del>	<del>6-28-77</del>	A
case studies	<del>G. Conventional Arms Transfer</del>	<del>6-28-77</del>	A
<p>Opened 5/12/97</p>			

FILE LOCATION

Chief of Staff (Jordan)/Box 2 of 8 (org.)/President's Reorganization Project--Decision Analysis Report--June 28, 1977

RESTRICTION CODES

- (A) Closed by Executive Order 12065 governing access to national security information.
- (B) Closed by statute or by the agency which originated the document.
- (C) Closed in accordance with restrictions contained in the donor's deed of gift.

PRESIDENT'S REORGANIZATION PROJECT

DECISION ANALYSIS REPORT

JUNE 28, 1977

Copy #7

DECISION ANALYSIS REPORT

TABLE OF CONTENTS

EXECUTIVE SUMMARY

1. INTRODUCTION . . . . .	7
2. CASE STUDY FINDINGS . . . . .	10
3. CARTER ADMINISTRATION PERSPECTIVE . . . . .	22
4. REORGANIZATION IMPLICATIONS . . . . .	27
5. CASE STUDIES	
A. FOOD STAMPS PURCHASE REQUIREMENT . . . . .	44
B. MINIMUM WAGE DETERMINATION . . . . .	61
C. SOCIAL SECURITY FINANCING . . . . .	72
D. FOOTWEAR IMPORT AGREEMENTS . . . . .	84
E. WIRETAP LEGISLATION . . . . .	97
F. BREEDER REACTOR PROGRAM . . . . .	110
G. CONVENTIONAL ARMS TRANSFER . . . . .	135
H. RURAL TELECOMMUNICATIONS TESTIMONY . . . . .	151

CONFIDENTIAL

(Unclassified Upon Removal of Case Studies E, F, and G)

DECISION ANALYSIS REPORT

EXECUTIVE SUMMARY

A. Purpose

The Decision Analysis project was undertaken to develop a better understanding of decisionmaking in the Executive Office of the President (EOP). As a study of EOP dynamics the Report provides a strong complement to the more static review represented by the functional analysis of Executive Office units.

No previous Administration has allowed a detailed study of its ongoing policy-making processes. No previous reorganization study of the Executive Office has ever been permitted to examine the way in which the staff system operates on concrete policy issues.

What has been attempted in the Decision Analysis project is thus unique, and has involved heavy demands on both the incumbents and on the project analysts to be open, exacting, and sensitive to the multiplicity of perspectives which involvement in the policy process naturally generates.

Eight case studies are included involving domestic and international affairs, encompassing a broad range of EOP units, and covering a variety of Presidential - and in one case - non-Presidential decisions. For each study the responsible analyst interviewed major EOP participants, examined supporting files, and reviewed the analysis with principals.

Insofar as the analysis identifies problems, the Report suggests how reorganization of both the decisionmaking process and the staff structure might avoid these difficulties, and might also assure the President of the reliability and efficacy of his Office in performing the roles he has assigned.

The following is a brief summary of specific case study findings and their reorganization implications. A full discussion of each point is provided in the supporting documents.

B. Findings

The findings below are derived primarily from the case studies and their analyses, but also draw upon information obtained in EOP unit studies by other analysts. The following problems have been identified:

(1) The Presidential Review Memorandum (PRM) process works well enough to be emulated for domestic policy formulation, but not well enough to be adopted without modification.

(2) The Economic Policy Group is not effective as currently operating. As a result, the President does not always receive a full and systematic staffing of economic issues.

(3) Departmental specialists have demonstrated high competence in support of EOP decisionmaking, but their utilization is inconsistent and inefficient, varying widely across policy areas.

(4) Strong departmental advocacy exists and should be balanced by early interdepartmental review by departments, agencies and EOP units (i.e., structured conflict).

(5) Political analysis within the EOP, related both to Congress and the broader political environment, is not applied to decisionmaking on a systematic basis.

(6) The advocacy and "neutral broker" roles performed by the President's policy staffs need to be more carefully delineated; in particular, the President's primary "issues handlers" (NSC, DC) should not allow advocacy to compromise their objective presentation of alternative viewpoints regarding policy issues.

(7) Follow-up procedures regarding Presidential decisions need to be formalized.

(8) Presidentially-imposed short leadtimes and the intrusion of crises into the EOP decisionmaking process make the development of better process control mechanisms all the more necessary.

(9) The form and content of written material for the President need to be better planned to enhance the use of the President's finite review time.

### C. Reorganization Implications

The case study findings above have the following structural and procedural implications for the Executive Office of the President:

(1) A Policy Staff Management System (PSMS) should be established for the formulation of domestic policy options. The Presidential Review Memorandum (PRM) process now used in foreign policy formulation should be modified and extended to the Domestic Policy staff process. The process would be the formal framework within which many (though not all) domestic issues would be developed for Presidential decisionmaking.

(2) The Economic Policy Group (EPG), if it continues to function as a Cabinet Working Group, should examine cross-cutting economic issues at the beginning, not the end of the policy development process. Its policy review process should be governed more broadly by an agenda-setting Senior Advisers group, and by a PSMS process as noted above. The EPG should be staffed by a major policy staff group, not by the Cabinet Secretary.

(3) White House units responsible for political strategy should be assigned collective accountability for the provision of critical political intelligence to the decision process. Development of policy options should reflect a detailed political assessment of congressional, public interest group, and general public reactions. The President and senior advisers should be alerted early of the need to discuss salient issues with key non-executive branch interests. Such discussions should then be scheduled in such a manner as to assure the possibility of real input to the policy development process. Coordination early may make cooperation more possible later.

(4) Two paper circulation processes now exist in the White House Office: The Cabinet Secretariat and Staff Secretariat. Though the two normally integrate at some point, this usually occurs too late in the process. To assure the most timely circulation of both Cabinet and senior White House staff papers, both circulations should be coordinated or controlled by the Staff Secretariat.

(5) The Policy Staff Management System (PSMS) mentioned above must include a detailed process for building and continually updating the President's decisionmaking agenda. Careful scheduling will not eliminate externally-induced decision situations; it will, however, provide a more controlled approach to decisions which can be predicted, and could also build in the organizational capacity to react to crises which do arise. Such a process might alleviate some of the excessive deadline pressures many EOP personnel have noted.

(6) The bulk of long-term (i.e., in excess of six months) policy planning should be delegated to the Cabinet departments. Nonetheless, to assist in the agenda-building process above, the President and his senior advisers should consider the establishment of small (i.e., 1-2 professionals) long-term policy planning groups who would be attached both to the domestic and national security policy staffs. These groups (later simply called the Long-Range Groups) would provide the staff link between the President and the long-term policy planning activities conducted inter-departmentally. If separate long-range groups seem infeasible, senior staff in each of the two policy staffs could be tasked with this forecasting responsibility.

(7) The President should build the capacity to review his decisionmaking apparatus periodically. Presidents historically have been unable to assess the performance of their Office. Through a combination of comprehensive interviews and case study analyses, the President might periodically reevaluate the EOP.

(8) Follow-up procedures for Presidential decisions would be incorporated in the PSMS process identified above. However, there should also be established a pilot data collection and management system to provide the President systematic indicators of the performance of the Executive Branch in selected areas (e.g., housing, employment, water project development, arms sales) of Presidential interest.

---

Supporting material with respect to both case study findings and reorganization implications is contained in sections 1-4 of this report. However, the case studies in section 5 provide the reader the fullest understanding of the symptoms identified in this summary. Section 2, by identifying the supporting case study(s) for respective findings, offers the reader a quick indication of case studies of direct interest.

SECTION 2 : CASE STUDY FINDINGS

DECISION ANALYSIS REPORT

## 2. CASE STUDY FINDINGS

This section identifies and describes problems documented in one or more of the eight case studies. The discussion highlights problems which seem to be amenable to reorganization actions, and offers the reader a direct reference to those case studies which most directly illuminate each specific finding.

### A. Economic Policy Group (EPG) Effectiveness

The Economic Policy Group (EPG) was developed to provide Cabinet coordination and review of the Administration's economic policies. Our case studies indicate that with respect to at least three issues - two primarily domestic and one primarily international - the EPG could have performed a more valuable service. It is ineffective in terms of its current objectives.

With regard to Conventional Arms Transfer, EPG was extraneous, and in process terms was passed over by the Presidential Review Memorandum (PRM) process. In Footwear, EPG aligned participants in terms of a narrow set of options that did not include the option finally adopted, and afforded the President an unstructured EPG meeting which may have actually misinformed the President regarding his true decision options. Finally, in terms of Minimum Wage, the EPG enabled participants to reflect existing agency positions (Council of Economic Advisers (CEA) and Department of Labor (DOL)), but did not expand the President's range of options.

In fairness the EPG did perform an option expansion function with respect to Social Security Refinancing. Here, however, the EPG entered the process so late that the alternatives surfaced in the meeting were understaffed by agencies which advocated them. Had the President wished to choose any other than the HEW proposal, he would have probably had to postpone final action.

### B. Presidential Review Memorandum (PRM) Utility

The Presidential Review Memorandum (PRM) system is utilized by the National Security Council staff to develop an orderly tasking and researching of international and security policy issues requiring Presidential attention. (The PRM process will be discussed in detail in section 4). The case studies indicate that the PRM process works well enough to be emulated for domestic policy formulation, but not well enough to be adopted without refinement. The discussion below indicates the potential nature of such refinements.

Three cases illuminate the PRM process: Breeder Reactors, Conventional Arms Transfer; and Wiretapping. Together the three cases support a mixed judgment regarding the effectiveness of PRM in establishing an acceptable tasking protocol for the development of Presidential decision options, which with respect to the PRM process are called Presidential Directives ("PDs").

On the one hand, PRM does in principle identify those EOP units and Cabinet departments which should be involved in the development of a given issue. However, in the case of Arms Transfer, the PRM did not adequately identify the issue in the first place. This is not a flaw in the process. It does suggest, however, that the success of PRM process is critically dependent upon a careful outlining of the issue(s) at the very outset. Extra resources applied at the front end may reduce overall effort.

In the Wiretapping case, PRM generated multiple lead agencies, stimulating competition and the need for a mid-process Presidential intervention. Here the problem was not issue identification, but rather a problem of inadequately delineating a single lead agency. Alternatively, recognizing the very strong and conflicting departmental interests involved, the PRM drafters might have specified heavier "honest broker" involvement of an NSC staff person.

The Breeder Reactor case is distinct from each of the two cases above, in that the issues were in some ways so broad as to preclude incorporation of all issues within one PRM process. However, the costs of a non-inclusive set of decision processes regarding Breeder Reactors were very high. First, the President was provided with uncoordinated decision memoranda over several weeks whose various options allowed the President to make decisions, each of which was slightly inconsistent with its predecessor. These apparent inconsistencies created decision ambiguities which afforded "decision losers" on the previous memorandum the chance to re-enter their preferred option for another discussion round.

The second case is directly related. This sequential recycling of decisions created a very high level of confusion among senior EOP staff. In some cases planned ambiguity creates flexibility; in this case, the ambiguity was unintended and created substantial administrative confusion.

Finally, the PRM process, while establishing procedures for coordination during the issue examination phase, currently excludes lead agency participation in the drafting of the Presidential Directive by the National Security Council (NSC) staff. This end-of-process exclusion may unnecessarily reduce the expertise applied to the actual document which reaches the President's desk, and may generate uncertainty among the agencies as to whether their views are adequately and objectively conveyed.

### C. Specialized Expertise

Three case studies highlight the use of specialized staff talent in the development of Presidential options: Food Stamps; Footwear; and Social Security Refinancing. In each of the three cases, primary technical support was supplied by non-White House staff, and in two of the three by non-EOP personnel. The case studies together evidence policy development strength where it is (and will be) needed: If White House and EOP staff are reduced, strong permanent government expertise is available and can be drawn upon. A Policy Staff Management System (PSMS), discussed in Section 4, would build upon this departmental strength.

In Footwear, the background issues paper (by the Office of Special Representative for Trade Negotiations (OSRTN) staff), raised and discussed an array of salient issues. In Food Stamps, the Department of Agriculture provided a broad range of cost and caseload distribution information related to the elimination of the purchase requirement (EPR) and marshalled support data for all decision options. In the Social Security Refinancing case, HEW performed analogous services, providing an articulate, comprehensive and well-thought out paper to the EPG, facilitating what was, by all accounts, one of the best-structured and productive EPG discussions to date.

#### D. Departmental Policy "Objectivity"

As a corollary of the specialization factor, the case studies document political common sense: that the Cabinet departments cannot be expected to espouse broad public interests. The departments by definition must respond to a narrower mission and constituency than the President's. A process (similar to NSC's PRM) is therefore needed which will assist in ensuring a timely and comprehensive inter-departmental consideration of policy issues. This accumulation of selectively narrow but distinct positions might afford the President a range of options more representative of broad public interests.

Several case studies illuminate this point. In the Breeder Reactor decision, for example, the experts at the Energy Research and Development Administration (ERDA) informed the President of a range of options in nuclear reactor technology from which the President could select. However, perhaps feeling that the plutonium fuel cycle would win through, ERDA failed to inform the President of the availability of alternative breeder fuel cycles - thorium, for example, - which offered him a middle position that would more adequately deal with the problems in Ohio and Tennessee that cancellation of Clinch River created. ERDA failed to provide this advice, and only very late in the process was the Science Adviser, Frank Press, able to point out to the President what was available.

In Minimum Wage, the Department of Labor (DOL) adhered through several meetings and memoranda to its position, and provided extensive technical material to support that position. DOL did not discuss alternative options. The same is true of HEW in Social Security: adherence to a well-staffed single agency option.

The point of these cases is obvious, but yet neglected: agencies can perform work of a technically superior quality, and can provide (as noted above) substantial policy support material. However, the President's decision prerogatives are only served if other agency and EOP positions are also requested very early in the issue staffing process. Otherwise, a

single-minded well-presented option will overwhelm the consideration of alternative positions. Key senior White House advisers must assist in this process by attempting to assess continuously whether the policy discussion includes representation of the array of interests-at-risk in the issue.

E. The Application of Political Information to the Policy Process

The case studies are relatively silent with respect to the generation of political information for decisionmaking. However, the absence of coverage results from the fact that there seemed to be very little systematic input to the process. The resources for EOP political analysis are not applied to decisionmaking on a systematic basis.

In the Minimum Wage case, Congressman Dent saw the President the morning the decision was made. Media coverage since that decision indicates that subsequent discussions have focussed heavily upon the political implications of the Administration position. In retrospect, a much earlier discussion - perhaps not changing the final decision - would have been valuable.

In the Breeder Reactor case, analysis documents the participation of the Assistant to the President and his staff only after the President's April 20 decision. Involvement after the fact becomes a fence-mending process; before the fact involvement may allow for the building of more useful congressional and public consensus.

A contrast is provided by the Foodstamp case. Extensive intelligence was gathered concerning Congressional opinion and content in advance of the Presidential decision. However, even here an external stimulus was necessary. According to a major participant in the case, the Washington Post disclosure of March 12 was decisive in clarifying to Administration officials working on the plan that they had failed to consult the one man whose opposition spelled almost certain defeat for the Bill - Congressman Tim Foley. Though very damaging as it appeared at the time, the Post article initiated a process of meetings and consultations which effectively won Foley over. Congressional committee staff were brought into the drafting of proposals and kept informed as the EOP discussions proceeded.

What resulted was little if any compromise on the part of the executive drafters of the foodstamps proposal, but a great deal less resistance on the congressional side. Foley was swung round from opposition to support, clearing the way in the House. Talmadge's opposition was not changed but was neutralized just the same, clearing the way through the Senate Agriculture Committee. The Chairman may have regarded the process as a personal defeat, but he saw the process as a fair and fully consultative one and accepted the defeat in good faith, itself an outcome which was valuable in the Senate Committee deliberations.

The case points to a major problem for the Executive Office. At present, Congressional Liaison is limited to a firefighting and crisis management role which absorbs almost all of its resources.

#### F. The Efficacy of Neutral Broker Roles

The question of Cabinet objectivity has been discussed above in terms of a reasonable expectation of policy advocacy at the department level. Such advocacy, it was suggested, should be counter-balanced at the department level through the inclusion of alternative department viewpoints. That counter-balancing function should be monitored by those staffs who serve the President as process managers (i.e., the Domestic Council, the National Security Council, and if it continues in present form, the EPG).

Analysis of the case studies indicates that the "neutral broker" functions of the President's policy staff need to be more carefully delineated in order to protect the President's ability to decide.

In the Social Security study, the Domestic Council became a strong advocate for a single position (HEW's), though other legitimate options had been presented within the EPG forum. Certainly, these other positions were unsupported by in-depth analysis, but the role of an advisory staff is to provide objective perspectives with respect to both policy ideas and the staff work which supports them. The Domestic Council focused too strongly upon the well-staffed HEW option, relegating alternative options to secondary status primarily because they were not developed as extensively on paper. An alternative Domestic Council approach more consistent with an honest broker role would have involved a fuller presentation of all options for the President, with the additional proviso that some options would require additional staffing. In actuality, the proviso was included; a fuller presentation of alternatives was not.

The Minimum Wage study raises a similar question, but a more complicated reaction, with regard to the role of the Council of Economic Advisers (CEA). CEA did provide technical support with respect to unemployment and inflationary aspects. However, no detailed treatment of indexing was presented, nor was there a systematic discussion of alternative indexing bases (CPI vs. average manufacturing wage). Moreover, CEA provided no sense of the range of options available to the President, choosing instead to counter the Department of Labor's position with support of their own option.

The CEA role in Minimum Wage does illuminate the complexity of its position vis-a-vis the Domestic Council. The CEA should be perceived more as an advocate of economic rationality in decisionmaking, than as an "honest broker" staffing out the economic implications of alternative decisions. However, if there is no other close support staff to the President which can provide an economic policy counterweight to CEA advice, then the CEA must accept a tension between the advocacy and advisory roles. The existence of an EPG staff separate and distinct from the CEA has resolved some of this potential role mix problem; EPG staff assignment through reorganization to the domestic policy staff would be a further step toward resolving the problem.

The Breeder Reactor case raises a related issue: the non-utilization of a Presidential adviser ideally positioned to perform a neutral, or honest broker function. Here, the Science Adviser to the President was screened out of the process until almost the end of the issue. There was almost no opportunity to apply technical advisory skills to an assessment of the decision.

The Footwear case exhibits another concern. In this study, one option, Orderly Marketing Agreements (OMAs), was dropped after the first EPG meeting, only to be raised verbally in the following meeting. However, it was not then supported by any written material to structure discussion. Given the fact that the case study indicates that the Domestic Policy Adviser, EPG, and STR knew about the option, the question becomes: should the President's advisory staff ensure that all useful options are analyzed on paper?

The answer is clearly affirmative, though in Footwear, Domestic Council intervention to assure staff analysis by OSRTN or EPG may have been precluded by confused role definitions between EPG and Domestic Council (e.g., should the Domestic Council intrude in the middle of an EPG issue analysis process?). As noted in the case studies there is a natural tendency for the departments to present only preferred options. However, since the "public interest" might be best served by a Presidential decision option which is no departments' first preference, only continuous scrutiny by the President's advisory staff will ensure the protection of the President's ability to decide.

A final concern in this regard is provided in the Arms Transfer case, and its discussion of the Presidential Review Memorandum (PRM) process. The termination of communication between those agencies and departments and the National Security Council staff regarding the final NSC preparation of the Presidential Directive may, in some cases, decrease the possibility that the NSC can perform a neutral broker function. This shift of lead agency responsibility provides an unfortunate discontinuity in the decisionmaking process.

#### G. Compliance

The case studies indicate insufficient EOP attention to adherence at the departmental and agency level to the intent of Presidential decisions. The decision follow-up process is not necessarily haphazard; there is yet the feeling that follow-up is performed less systematically than would seem appropriate. Follow-up procedures for Presidential decisions need to be formalized.

The Breeder Reactor case is instructive in this regard. As a consequence of poor issue identification and agency involvement initially, logically related issues were not related, logically related memoranda did not arrive at the Oval Office together, and the consequent decisions were sufficiently unsynchronized as to confuse affected parties.

The confusion over the meaning of the President's decision then resulted in incomplete follow-through and a reopening of the decision process. The obvious theme returns us to the beginning of the process: the best way to achieve policy adherence is to reach an earlier definition of the problem, so as to clarify the parameters of the decision process, and thereby to clarify the meaning of the decision per se. At that point, a follow-up mechanism will help to ensure proper pursuit of a clear Presidential decision.

#### H. Deadlines

The case studies exemplify the intrinsic tension which exists in staff work between adherence to a deadline and product quality. Deadlines are easiest to maintain if four conditions obtain: (1) excess staff are available to deal with peak loads; (2) detailed procedural guidelines exist to handle decisionmaking processes; (3) the tasks themselves impose routine requirements; and (4) no unforeseen events intervene to consume staff time.

Our analysis indicates that none of the conditions noted above are now operative. With respect to Condition (1) (excess staff), the President has clearly indicated a desire to reduce staff. The Breeder Reactor, Minimum Wage, Wiretap, and Arms Transfer cases cast doubt on the existence of Condition (2), durable procedural guidelines. With respect to routine tasks, Condition (3), the cases suggest though processes for handling some issues may be devised, many issues may continue to be original (i.e., requiring non-routine combinations of analysis), and therefore organizationally challenging. Finally, external events always intervene, violating Condition (4). Elizabeth Drew made the point in a recent New Yorker article:

"The President....set an agenda and deadlines  
....but he found himself faced with an even  
larger agenda and even more deadlines imposed  
by others.

With respect to Social Security Refinancing, it appears that no senior staff foresaw the extent to which the London Summit would reduce the President's ability to focus on domestic issues. Therefore, the Social Security decision received less Presidential time than otherwise would have been accorded it.

In Minimum Wage, a delay in EPG discussion pushed final option development to within 18 hours of Secretary Marshall's testimony. In Breeder Reactors multiple uncoordinated deadlines forced incremental decisions on discrete issues, and abrogated the integrated consideration of the package of those issues. In Arms Transfer all participants noted the excessive time pressure, to the point where an uneasy trade-off was implied: an early much less informed decision vs. high quality analytic support.

The Footwear case is germane here, but in a different way. Here, high level discussion by principals seems to automatically shut off further in-depth exploration of issues. Because OMAs had been eliminated after the first round of discussion, they were not carried along in the subsequent draft memorandum for the following week's EPG discussion. However, OMAs were reintroduced at the meeting, but from all accounts in a very messy context. Nonetheless, the press of an April 8 deadline (or perhaps just "organizational momentum") obviated the possibility of systematically specifying OMA vs. voluntary restraint options. A decision was then made April 1 to go with OMA.

In summary, self-imposed short leadtimes and the intrusion of crises into the EOP decisionmaking process mandate the development of better process control mechanisms. Deadlines and work quality are normal problems, but staff limitations, uncontrolled events, and non-routine issues create three process requirements:

1. Long-term scheduling.
2. Precise decision process guidelines.
3. Reliance on non-EOP government personnel.

#### I. Presidential Relevance

The relevance of issues and organizations to Presidential decisionmaking is a key reorganization inclusion criterion. The criterion has at least three components:

1. Should the unit's functions be performed in the EOP?
2. Should the issue be resolved by the President?
3. Even if the issue should be resolved by the President, in what form and quantity should Presidential material be presented?

The case studies illuminate all three questions. The Rural Telecommunications case raises the first question, of EOP inclusion: Was the issue of rural telecommunications policy so critical as to require the direct involvement of a Presidential aid in the Domestic Council? The case notes this was a temporary arrangement; and, of course, other Office of Telecommunications Policy (OTP) issues may have been more salient. Yet, the case suggests that even this temporary arrangement may have been too permanent.

The wiretap case raises point two. The President should be involved at the beginning of an issue analysis process (to prescribe the Presidential policy boundaries within which the issue should be developed) and at the end of the process, when decision options with respect to an issue are presented to him. There is less reason, excepting his direct preference, for the President to be involved in the middle, as he was in Wiretap, to resolve jurisdictional disputes regarding lead agency status. Given the degree to which his intervention seemed to resolve process conflicts, however, an infrequent Presidential intervention may be efficient.

The third point - the form and content of Presidential papers - requires internal management attention. The case studies collectively indicate that much greater planning should go into the form and content of Presidential papers. This is particularly so given this President's reading proclivities.

In Breeder Reactors the President was compelled to re-focus on the issue several times with new papers. In Minimum Wage, technical appendices were submitted to support two positions, but seemed inappropriate to Presidential review. The President needs findings and implications, not research. In Footwear, four separate memoranda were submitted, all focussing on the same issue but none providing an accurate synthesis of the problem. The Social Security Refinancing package included five papers. Again, no one paper synthesized the five. Together, they must have been intimidating to even a speedreading Chief Executive.

Written Presidential communication needs to be better planned in terms of both form and content to enhance the President's use of his finite review time.

DECISION ANALYSIS REPORT

SECTION 3: A CARTER ADMINISTRATION PERSPECTIVE

### 3. A CARTER ADMINISTRATION PERSPECTIVE

The Executive Office of the President is -- or should be -- exactly that: the President's Office. Whatever the other criteria for proposing organizational refinements within the EOP, a foremost consideration should be our best perception of those decision-making processes and structures which are most consistent with the President's organizational objectives and style. The following is a brief definition of those objectives as inferred from both available statements of Presidential intentions and his public activities.

In discussing these "decisionmaking objectives" it is important to note that the Carter Administration is still evolving. No large organization settles in over a five-month period. Consequently, the Carter decisionmaking objectives presented below are inferences of objectives which are yet being formulated and refined. We recognize the possibility of change in those intentions, and have attempted in the subsequent section to harmonize our reorganization proposals with direction of the changes which may be occurring naturally.

Our "snapshot" of current objectives includes the following:

#### A. Efficient Management

In a question and answer session at the State Department, the President stated:

"I am deeply committed to the principle that we ought to have an efficient, economical well-organized, well-managed Federal Government."

The image conveyed is of a tightly organized and defined government. One should infer the same objective to the design of the President's own decisionmaking apparatus.

#### B. Cabinet Government

In his swearing-in of several Cabinet members on January 23, the President emphasized the importance he assigned the operation of Cabinet government:

"There will never be an instance, while I am President, when the members of the White House staff dominate or act in a superior position to the members of our Cabinet. When a directive is relayed from the White House to the members of the Cabinet, it will indeed come directly from me.

"I believe in a Cabinet administration of our Government. And although the major decisions will be made ultimately by me as President, which is my constitutional prerogative and responsibility, the Secretaries will run their Departments. And this is the way it ought to be."

The President has since reinforced this concept, including remarks at the White House Conference for the Business Community on February 9:

"I do have one thing that need not cause you any concern. Because of the quality of my Cabinet officers and their own independence, I think you might find a reduced need to come directly to the White House for an answer to a question or to relieve a problem that you might face... You can go directly to those Cabinet members. They speak for me. They speak with authority. They speak with sound judgment. And they need your help just like I do."

These statements indicate the President's commitment to a decisionmaking process broadly inclusive of the Federal departments. Such an objective requires heavy communication between the Executive Office of the President and the Cabinet, and clear collective understanding of Presidential policy. The case study findings suggest that in some cases such understandings could indeed be made more clear.

### C. Multiple Policy Initiatives

The absolute number of issues pursued by the Carter Administration thus far has a substantial impact upon the quality of the decisionmaking process. If decisions are to be made by the President in several policy areas (i.e., water projects, farm price supports, reorganization, the energy package, minimum wage, the environmental message, the Economic Summit, welfare reform, social security

refinancing, and others), and must therefore be staffed out by at least one (usually several) EOP units, then there is the potential for staffing overload at the senior EOP level. The simple quantity of Presidential policy initiatives therefore becomes an "objective" per se and affects the quality of the decisionmaking processes employed.

#### D. Openness

The President has indicated his desire to provide greater access to the governmental process. The objective has been operationalized in a variety of ways depending upon the issue involved. If access involves some form of participation in the decisionmaking process by selected publics (e.g., trade associations, interest groups, individuals), the price paid is usually delay, additional staff energy (to consume and respond to new participant "input"), and early compromise of decision options. Sometimes the price is cheap, if one gains a better decision and a greater willingness to accept and implement it. The case studies document the need for better (i.e., more structured and open) input from both the general public (via public interest groups, associations, and citizens) and the Congress.

#### E. Simplicity and Responsiveness

This objective is again less explicitly stated than others, but is consistent with the idea of openness. An open process is of little consequence if the process is either unnecessarily complicated or ultimately non-responsive. With respect to decisionmaking, the relevant question is: Does the decisionmaking process involve those units and individuals within the EOP that should be involved? Were the contributions of those units responsive in some manner to the multiple publics to which such EOP units might relate?

#### F. A Decentralized Senior Staff

The President has indicated a desire not to have a "Chief of Staff," relying instead upon a number of channels of communication to the Oval Office. This objective has a substantial impact upon (1) the level of "issue consensus" which reaches him, and on (2) the quantity of information which he must consume. The first effect increases his decisionmaking flexibility, but the latter reduces the time and energy he may apply to each decision and may eventually reduce the number of issues which he will be able to handle.

Pushing issues down to lower levels may, however, be a quite favorable outcome, if the decisionmaking process pushes down the right issues.

An appropriate decisionmaking structure must strike a balance between the need for multiple advisory channels on the one hand and for economy in the use of the President's time on the other.

#### G. A Reduced White House Staff

The implications for decisionmaking attendant to a reduced White House staff are enormous. Organizations normally attempt to reduce the possibility of decision-making error through a combination of two techniques: 1) maintain excess staff which can be applied quickly to cover crisis situations or to apply additional review layers; and 2) develop elaborate procedural guidelines such that most routine decisionmaking issues and situations elicit consistent and predictable responses. However, since many Presidential decisions are non-routine, and are required because no "policy" has been established, the second error reduction tactic is not available to the EOP. More elaborate policy process management guides are therefore needed, particularly since White House staff reduction will undermine the alternative error reduction tactic: staffing redundancy. Extra staff, it should be noted, may on occasion increase the potential for error and confusion.

#### H. The President's Research Time

This "objective" or style can be inferred from the ongoing analysis of the President's use of time prepared by the scheduling office.

According to their analysis, more than 40% of the President's working hours over the first 12 weeks were consumed in "private working time" (which includes telephone conversations and perhaps undocumented evening meetings with advisers). The reorganization inference to be derived from this finding is that to the extent that such time is spent reviewing decisionmaking packages, reorganization proposals should incorporate a careful consideration of the format, content, and quantity of material provided to the President.

These objectives and style considerations are reflected in the next section, the reorganization implications of the decision analysis report.

SECTION 4 : REORGANIZATION IMPLICATIONS

DECISION ANALYSIS REPORT

#### 4. REORGANIZATION IMPLICATIONS

The following are structural and procedural suggestions which build upon the case study findings, Presidential style considerations noted in section 3, and upon more general discussions among EOP reorganization staff.

The proposals below will be reflected in different ways within the specific options papers. Moreover, some proposals such as the Policy Staff Management System discussed below, will require modification in order to conform with each of the several major organizational alternatives. In that sense, these proposals provide the detailed framework for discussion of those alternatives.

##### A. Create a Policy Staff Management System (PSMS)

The most conspicuous and pervasive weakness identified in the case study analysis has been the absence of an integrated decisionmaking process for domestic policy formulation. The discussion below proposes such a process modified from Presidential Review Memorandum (PRM) process already in place under the National Security Council (NSC). The process would be called the Policy Staff Management System (PSMS).

The PSMS would govern policy development activities in both the domestic and international affairs areas, basically by applying similar process management techniques to both the Domestic Policy Staff (DPS) and the National Security Staff (NSS) ("Council" is dropped from the title to distinguish staff functions from Cabinet convening functions; the National Security Council would only exist when Cabinet principals met for discussion). The DPS and NSS would become the key Presidential staff support units under this arrangement. The system would function within the following general guidelines:

##### (1) Purpose

The fundamental intent of the "policy staff management system" is to foster the development of coordinated, Cabinet-oriented government. The policy staff(s) would act as

the coordinating and facilitating bodies which insure the preservation of Presidential perspective in the interagency development of policy and programs. The staffs would also provide the mechanism for establishing the long-range goals or purposes of the government and obtaining a mutual commitment to those goals by the Cabinet members.

It is not our intent that this system somehow reflect all contingencies or all "policy issues." No system can, nor can any scheme eliminate occasional untidiness, the frequent need for informality, or less often, the base process of "muddling through" in the resolution of Presidential issues. Recognizing this reality, the framework below provides a system which in modified form has worked for the NSC, and with appropriate adaptation can work for domestic policy. Moreover, in those cases where "muddling through" does seem the wisest course, the PSMS provides a standard of comparison.

For purposes of discussion the policy development functions of the EOP can be divided into five distinct phases. The comprehensive nature of the PSMS insures proper attention to all five, yet maintains sufficient flexibility to cope with the inherent uncertainties of the policy process. Simply stated the five phases are:

- a. Goal setting/agenda planning and prioritization.
- b. Issue identification/assignment of responsibility.
- c. Policy analysis/option formulation.
- d. Recommendation/decisionmaking
- e. Implementation/compliance/reassessment.

The system is illustrated in Figure 4-1.

## (2) Goal Setting

The first activity is an extension of the Presidential calendar currently being prepared by the Vice President's staff and the agendas developed during transition. In the policy staff management system, responsibility for policy forecasting would belong to small (1-2 professionals)

long-range groups in the two policy staffs. Through consultation with other policy staff members, departments and agency staffs, and other EOP White House staffs, direction from the President and Vice President, and initiatives by the White House senior staff, the long range groups would develop separate domestic and foreign policy goals and agenda covering periods six' to twelve months into the future.

The basic purpose of such agenda would be both to reduce the number of "short leadtime issues" which are self-generated, and to provide a better linkage of several short-term policy issues to larger concepts. For example, a long-term agenda might help establish a consistent overall trade policy within which specific trade issues (e.g., specialty steels, mushrooms, footwear, sugar, and television) could be considered.

These goals and agenda would be forwarded through the Assistants for National Security and Domestic Affairs, respectively, to an Executive Committee of the senior staff for initial review and comment. That Executive Committee might include the OMB Director, the Chairman of the CEA, the Assistant to the President, and the Assistants for National Security and Domestic Affairs. The Vice President might also be included, depending upon his preferences.

2816  
STU  
LANCE  
SCHULTZ  
JORDAN  
+ MOORE

After the Executive Committee had reviewed and consolidated the agendas, the single agenda would then be circulated among the senior staff for review and comment. The purpose of such a consolidated domestic/national security agenda would be to specify in written form the complex decision schedule imposed by the separately driven staff agendas. Presumably, the consolidating process itself would force many rescheduling decisions.

At the conclusion of this phase the single agenda would be submitted to the President for approval. Depending on the situation, the Executive Committee would meet biweekly to assess the continuing appropriateness of the agenda, and if necessary update the agenda to reflect changing contingencies. Of course, numerous short-term issues will not be anticipated within this six-month to one-year agenda. Nonetheless, a properly prepared schedule would both provide some slack time for such

contingencies and would indicate, where possible, the appropriate lead department and senior staff adviser for the disposition of crisis problems in specified areas. In such a manner, this agenda building process would at least partially address "crisis management" needs. Untidiness would, of course, not disappear; there would, however, be an alternative to it.

### (3) Issue Identification

Issues arise from a variety of predictable and random sources. Some would emerge from the agenda building process above; others would be generated through the long-range group staff in the DPS or NSS. A majority of issues would presumably emerge from sources external to the EOP (i.e., from Congress, the public, national disasters, international incidents).

Once identified, an issue would be communicated to either the DPS or NSS for first review. (Issues with significant domestic and international components would require contact between the two staffs.) If the issue were deemed sufficiently important to warrant Presidential attention, a draft Policy Review Memorandum (PRM) would be prepared. Very "short-fuse" issues would, of course, bypass much of this system. Nonetheless, the system could identify "most probable participants" for at least telephone consultation.

Issue identification would then be handled much the same as the "Presidential Review and Directive Series" used by the National Security Council System.\* Figure 4-1 on the following page outlines the process. The PRM is drafted by the appropriate policy staff, and coordinated at the working staff level to assure incorporation of germane department or EOP unit comments. The draft PRM then is submitted to the President, and contains the following points:

---

\* Presidential Directive/NSC-1 of January 20, 1977, describes the Review and Directive Series. Presidential Directive/NSC-2 of January 20, 1977, and NSC Memorandum entitled "Executive Order 11905, and PD/NSC-2," January 26, 1977, describes the National Security Council System.

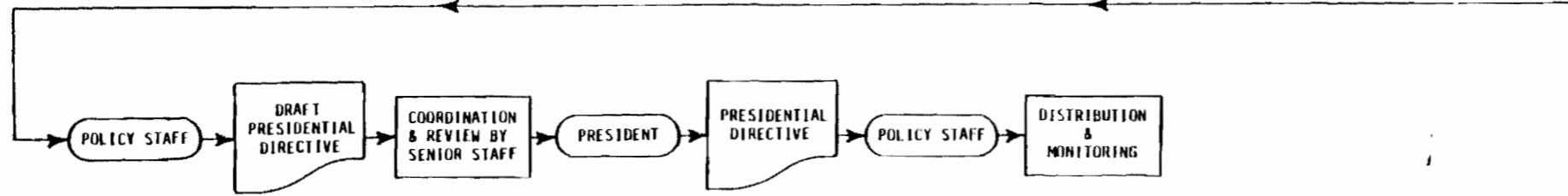
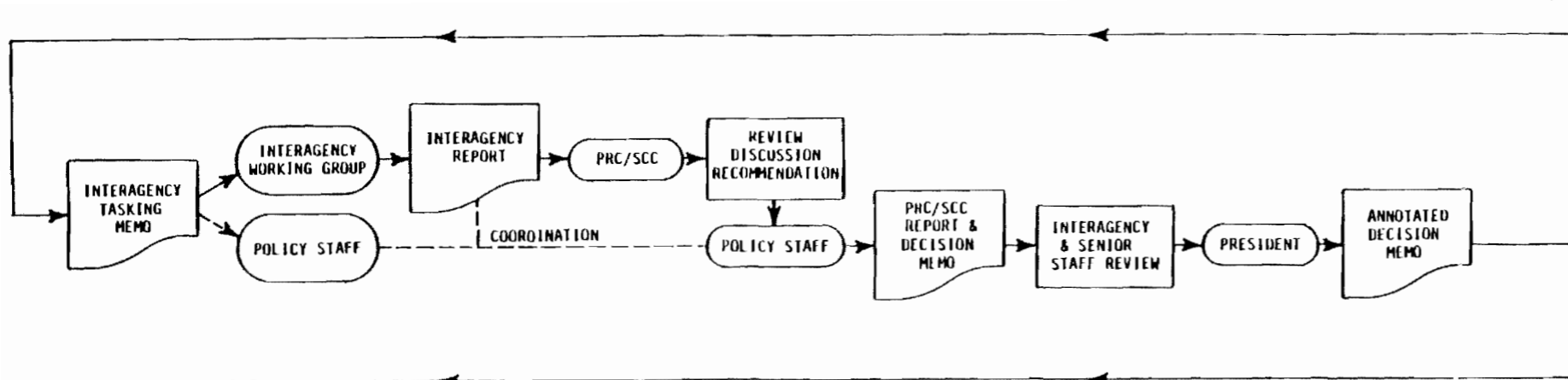

- o A description of the issue and its significance.
- o An identification of lead agency staffing responsibility.
- o A task assignment to the lead agency and other participating units.
- o A schedule for completion of a Presidential Directive (PD).

If accepted by the President, the PRM then returns to the DPS or NSS and is transmitted to the Policy Review Committee/Special Coordinating Committee (PRC/SCC) to begin the actual policy analysis and option formulation process.

The PRC is an interagency group currently responsible for developing national security policy for Presidential decisions in those cases where basic responsibility falls primarily within one department but where the decision would have major implications for other departments. The SCC primarily develops policy on cross-cutting issues which require a great deal of coordination. An overall Policy Staff Management System would include both a PRC and SCC with a differently constituted principal membership to cover domestic issues. The composition of both would change depending upon the specific issue in question.

#### (4) Policy Analysis/Option Formulation

Two important points characterize this policy analysis phase. The first is that wherever possible (a majority of cases), this phase of the PSMS process is staffed by units outside the EOP. The DPS or NSS staffer provides a continuous link between the White House and the working groups to set the outside limits of issue discussion, but is not normally responsible for the day-to-day staffing work. The exception to this proviso is when the interests of two non-EOP units are so intense as to warrant more "neutral" chairing of an interagency task force by a DPS or NSS staff member.

The second point also differentiates this proposed process from the policy formulation patterns documented in this report. This process intentionally forces interagency involvement at the outset of the policy formulation process. Such early involvement reduces the possibility of a narrow approach to the issue.

Such expanded participation does consume more time at the outset. However, our case studies suggest that time not spent early in cooperatively focussing on an issue will be spent at the end of the process in competitive attempts to stop a narrowly formed set of policy options from reaching the decision phase.

(5) Recommendation/Decisionmaking

In the normal PSMS case, the working document is developed by a Cabinet-chaired group, submitted through the PRC/SCC, and leads subsequently to the formulation of final options, and (where a strong consensus has emerged) a particular recommendation by the department principals.

The options, recommendations, and final discussions are then incorporated in a PRC/SCC report and Decision Memorandum. The package is submitted to the White House Staff Secretary, and quickly routed to Cabinet and White House senior staff for comments. However, unlike the current process, if this last circulation process produces comments which qualitatively change the sense of the Presidential Directive, then the comments will be incorporated into the PD, not appended to it. Certainly, in some cases, timing may preclude this final step. Nevertheless, the intent of the process is to produce one useful working document for the President, not several at slight cross-purposes to one another.

(6) Implementation/Compliance/Reassessment

Decisionmaking can be meaningless without assurance of compliance. Therefore, after the President has reached a decision, the policy staffs would monitor, as Presidential umpires, the implementation of the policies and the progress towards the goals being achieved by the various agencies of government. Such monitoring would be

enhanced to the extent that the long-range groups in both NSS and DPS identified program indicators within major Administration goal areas. With the assistance of both departmental personnel and OMB ZBB specialists, the two staffs could also develop a continuous goal monitoring system employing quantifiable program measures. Though ambitious in intent, even partial attainment of such a system could increase the President's ability to maintain an ongoing perspective regarding key policy areas. A monitoring system should be attempted on a pilot basis.

B. Redefine the Role of the Economic Policy Group (EPG)

The case studies and numerous interviews with EOP officials reinforce this proposal. The EPG has not worked well for several reasons:

(1) EPG meetings too often address issues seriously only at the decision-end of the policy option development process, rather than at a much earlier stage.

At the end of a process, agency positions are highly researched and staffed, and incorporated in staff papers presented to the EPG. If alternative viewpoints have not been carried along in the process, and also afforded detailed analysis and review, they are unlikely to be considered serious options for Presidential consideration, simply by reason of the momentum built into any decision process. Therefore, though such options might emerge in the course of an EPG discussion, the weight of researched positions and decision deadlines will overwhelm serious consideration of these options.

If an issue is important enough to warrant review by Cabinet officials (more on this below), it is sufficiently important to obtain Secretaries' perspectives early enough to affect the issue staffing process. Certainly, this "front-end" EPG approach will not be easy to implement. Agency self-interests militate against the exposure of "their" proposal to cross-cutting peer review. Therefore, if EPG assumes a "front-end" approach, the identification of EPG agenda items will be a critical component of the process. Such identification could occur through the "long-range groups" established within both the National Security Staff and the Domestic Policy Staff.

(2) The EPG may be addressing the "wrong" issues.

For a Cabinet forum to be effective, there must be a good match between the agenda and participants' skills and responsibilities. Applying this self-evident position to the EPG, however, creates a mismatch. The EPG did not address the energy package, though that package may be the most "interdepartmental" of all issues. The EPG did not discuss trade policy in general, but has dealt with a trade decision (e.g., footwear). In short, the EPG may be addressing those issues in which Cabinet Secretaries might have the least comparative advantage. From this perspective, the "right issues" would seem to be comprehensive issues (i.e., anti-inflation package, macroeconomic policy, long-term collective bargaining imports, government transfer payments) requiring initial Cabinet positions through which to guide subsequent staff work. Such initial guidance would assist the President in expanding as well as deepening the scope of the analysis brought to bear on a set of related policy issues.

(3) EPG staff cannot, as currently structured, perform an "honest broker" role.

The President relies primarily upon his Domestic and National Security Advisers for "synthesis" of the range of options relative to a given decision. Consequently, an EPG option paper -- written as if it were the final options paper -- is of little utility when it is covered as a matter of procedure by Stuart Eizenstat. For this reason, the EPG staff should be assigned to the Assistant for Domestic Affairs and Policy. Should a more formal Domestic Policy Staff (DPS) be developed under the Policy Staff Management System, the staff in DPS assigned to EPG would presumably also work on other interdepartmental groups.

In summary, EPG should:

- o Engage in front-end discussions of selected policy issues.
- o Select general comprehensive issues as opposed to specific narrow ones.
- o Utilize staff reporting to the Assistant to the President for Domestic Affairs and Policy.

If a PSMS is adopted, the EPG would function, presumably, only when tasked to do so under a Presidential Review Memorandum action. Alternatively, the EPG would remain as one of a few standing committees with a presumptive right to focus upon economic policy issues.

C. Develop a System for the Inclusion of Political Intelligence

Politics is no more an art than is economics or public administration. Since almost all issues which reach the Oval Office get there because of legitimate differences of opinion, there is every reason to develop the most systematic assessment of political positions in Congress, the special interest groups, and other less organized public constituents. The decision analysis study as well as other EOP interviews suggests that political intelligence is applied haphazardly to the decisionmaking process.

The following White House staff are in a position to develop the necessary system:

- (1) Vice President
- (2) Counsel to the President
- (3) Assistant to the President - Jordan
- (4) Assistant to the President - Public Liaison
- (5) Assistant to the President - Congressional Liaison
- (6) Special Assistant to the President - Administration
- (7) Special Assistant to the President - Mitchell
- (8) OMB, and Departmental Congressional Relations Staff

Given the proximity of these units and individuals to the President, it would be presumptuous to detail the manner in which political intelligence could be applied to the process. However, it is possible to suggest the principles which should be employed in developing the system. At a minimum, the "system" would:

(1) Identify a lead political analyst for each policy issue generated by the PSMS process.

(2) Identify key interests at risk in the decision.

(3) Schedule appropriate contacts with key representatives early in the policy formulation process. (Some contacts might involve the President; most would involve departmental and White House personnel.)

(4) Provide political assessments of each of the major options under review, in a sufficiently timely manner to allow for full discussion of political implications before final option preparation.

(5) Identify the potential congressional "bargaining market" within which a Presidential decision will be placed (i.e., will Congress separate farm price supports from food stamps?).

There is no expectation that a "system" modeled around the above five points would be a panacea, nor that it would act like a system for all issues. Nevertheless, no "model" exists now against which to compare White House performance. At the very least, the definition of a system in operational terms would help direct this key policy development component.

The Congressional Liaison role requires particular attention. The job is done as well as it can be in the circumstances, but to serve the President's needs more effectively the role needs to be broadened and the resources available improved.

What is needed is an organizational design that will permit more effective tactical maneuver. At present, the Senate side of Congressional Liaison is designed for general coverage of the Senate floor, while the House side is organized to mirror the agencies rather than the Congress itself. In neither case does the Office organize its staff to follow Senate and House Committees. This limits its capacity for advance intelligence on program development and confines its tactical operations to the late stages of committee mark-up and floor votes. Targetting of resources follows bills rather than committee agendas, and catches up with proposals only when they have reached the

point of a vote that overshoots the Administration's budget ceilings or flies in the face of Administration commitments.

This in turn requires the President to do more threatening and bluffing than is tactically desirable, eroding slowly but surely the credibility of both the President's negotiating strength and of the policy-making process which sends proposals to the Hill at the outset.

What is also needed is more effective strategic planning of liaison operations. This would seek coordination of the roles of the Jordan staff, the Domestic Policy staff, OMB legislative reference, and the relevant agency staff well in advance of the submission of major program initiatives. Effective strategic planning in the early stages saves tactical resources at the late stages and limits the number of conflicts with Congress on which the Administration needs to expend "bargaining chips."

One final point relates to political strategy. The greatest price the Administration has had to pay for conscious or unconscious secrecy in program development and policy review has been in its congressional strategy. While premature disclosure can often have an adverse effect on effective policy review in the EOP, the lack of congressional consultation that it requires can mean almost certain death for the policy package when it reaches the Hill.

D. Merge the Paper Circulation Processes of the Cabinet Secretary and the Staff Secretary

This action would streamline a circulation process which at times generates either delays in the delivery of key communications to senior White House staff, or a lack of knowledge on the part Cabinet officials regarding the progress of their paper (i.e., "Has the President seen the memo I am scheduled to discuss with him today?").

Placing both circulations under the Staff Secretary would help to assure that a larger number of relevant Cabinet and White House staff would see papers at the same time, and would also increase the possibility of a good process control of Presidential communications. Moreover, this routing function is separable from the Cabinet Secretary's larger, representational duties.

Under such consolidation, Cabinet communications would still be channeled into the White House through the Cabinet Secretary to assure that he remains fully informed of Cabinet perspectives. There would be a consequent increase in the potential authority of the Staff Secretary (i.e., screening, rather than simply circulating papers); should this become a problem, decision rules more clearly detailing "gatekeeper" responsibilities could be added.

E. Design and Maintain a System Review/Decision Analysis Process

The process of developing this Decision Analysis Report has generated this proposal, supported by an historical perspective. A review of the President's advisory systems should be conducted periodically. Presidents come to office with predilections and preferences in style that frequently are internally inconsistent, and even more frequently do not suit their job or their priorities as they come to define them. They make some appointments that mesh with these preferences and predilections, and some that do not. Yet, they are unlikely to take a serious, overall second look: they are busy and they don't want to admit failure in their original efforts.

The decision analysis supports the need to look back over the process. How well is the system serving the President? How much has the system in place changed? Has the change been favorable?

Reorganization is a continuous process. It should be as concerned with process as much as it is with structure. Building in a mechanism for change strengthens the potential for success by identifying activities, structures and processes that contribute to success and failure. Such an approach revitalizes any organization. It insures continued flexibility, builds on accomplishments, consolidates gains and builds structures and processes that the President can pass on to succeeding Administrations.

The methodology for such a review would be similar to this decision analysis process, in that case study material offers the possibility of in-depth study in a few major areas. This process would be complemented by more general interview methods, which gain in breadth of coverage what the case studies achieve in depth.

More important than how such a review is conducted is the function of who conducts it. Ideally, the group would consist of individuals independent of the EOP who yet have a sufficient working knowledge of the EOP to perform the review expeditiously.

A review process applied periodically (every 18 months perhaps) eliminates the need for permanent staff to administer the review function, while simultaneously synchronizing the review more closely with normal staff turnover periods. What is lost in this periodic review -- as opposed to continuous monitoring -- is that dynamic sense of an organization in evolution. Reviewees recruited from outside the EOP would necessarily experience a new learning curve at each period. Permanent review staff have the opposite problem: knowing the organization too well to establish an objective perspective.

Conclusion:

- (1) The review should be implemented.
- (2) The review approach should combine decision analyses and more comprehensive interviewing.
- (3) Professional independence might best be maintained through the use of skilled personnel hired on a temporary basis.

F. Explore the Possibility of a Program Indicators System

No system now exists to afford the President a quantifiable measure of the "output" (whether that output is in the form of services, products, or processes) of his government in operational terms. Although this suggestion is beyond the immediate purview of the decision analysis report, the team proposes that the President consider the development of a pilot program employing a series of indicators in selected program areas to measure the progress of Federal departments in key Presidential program areas. The indicators could be developed by National Security Staff and Domestic Policy Staff personnel working closely with interdepartmental policy staffs.

Should the pilot process seem valuable, the coverage of these indicators could be slowly expanded, with the long-term objective being the establishment of a social program report system to the President.

The proposed process builds upon a general need for better governmental accountability, as now manifest in the attempt to apply ZBB across the government. A social report system is fully consistent with that effort, but should be initiated on a very limited scale in order to avoid the normal oversell problems of "new" ideas (this is not new) and also, of course, to simply test its utility for this Administration.

SECTION 5 : THE CASE STUDIES

DECISION ANALYSIS REPORT

CASE STUDY: FOOD STAMPS PURCHASE REQUIREMENT

DECISION ANALYSIS REPORT

## A. FOOD STAMPS PURCHASE REQUIREMENT

### 1. ABSTRACT

This case study examines the process by which a new Carter proposal was developed. It is unusual in several respects. The President spent relatively more personal time on the issue than in other cases which have been analyzed; it came to Cabinet's attention more frequently. On the other hand, development of the initiative rested almost entirely on a single division of a Cabinet agency (USDA). Coordination of interagency efforts was thus less necessary in this case but satisfactorily accomplished. Within the EOP, units of the Domestic Council and OMB worked smoothly together. Congressional response was well tested in advance.

The key to the success of the process was the utilization of a high degree of expertise in assessing a series of complex program options which changed substantially in detail, impact and cost over the course of the decision process. This resulted in detailed costing of decision alternatives and limited to an unusual degree the amount of guesswork as to the impact of the decisions toward which the participants were moving. The role of expertise was instrumental in informing the final expression of the President's view. Insofar as the case exemplifies an effective decisionmaking process, it carries an important lesson for reorganization -- the need for the necessary expertise was served not from inside the EOP, but rather from the agency involved, at the call of the OMB program staff (principally) and the Domestic Council staff (secondarily).

### 2. BACKGROUND

In this section, day-by-day events are chronicled in order to identify the important issues and key players as these emerged.

o Key players or active participants in the decision process are identified as those individuals who interact on the food stamps issue outside their EOP unit or agency, and do so more than once. Attendance at an interagency meeting is treated as multiple interaction for this purpose. For full list, see pages 12-13.

o For summary data on Presidential and Cabinet attention to the issue, see page 12.

### Chronology

#### January

- 18 S. 275, Senator Talmadge's Farm Bill, is introduced in Congress.

#### February

- 24 Food and Nutrition Service (FNS) of the Department of Agriculture (USDA) sends a document outlining the impact of the Department's draft bill to OMB for review.
- 28 A draft version of the "Food Stamp Act of 1977" is sent to OMB. The principal authors are John Kramer of the staff of the House Committee on Agriculture and Bob Greenstein, Special Assistant to the Secretary of Agriculture. At OMB, the document is reviewed by David Kleinberg, Chief, Income Maintenance Branch, and John Ostenso of OMB.

- o Mike Barth (HEW) calls Bob Greenstein expressing concern that his Department is not being plugged into the development of the food stamps program. This call is followed by a series of consultations over the phone between Greenstein and a number of HEW officials. These are greatly facilitated by the fact that the year before, during the Ford Administration, Greenstein and two of his opposite numbers at HEW had worked closely together on the program from outside the Government.

#### March

- 2 Lynn Daft (Domestic Council staff) sends a memorandum to Stuart Eizenstat via Bert Carp, outlining the USDA food stamps proposal.
- o Southern Coalition to Eliminate Hunger writes Carp urging the elimination of the purchase requirement for food stamps (EPR). Carp forwards the document to Raines and Daft (DC).

- o Carolyn Merck, Program Development Branch (FNS, USDA), writes memorandum to Bob Greenstein outlining costs for three of a series of food stamp program options. The options were (1) \$100 standard deduction, with special deductions for child care and work expenses; (2) \$80 standard deduction; and (3) a standard deduction graduated for household size.

March

- 7 Senators McGovern (sponsor of S. 845) and Humphrey (S. 903) write the President urging elimination of the purchase requirement (EPR).
- o Staff analysis of the food stamp bills pending in the Senate is released by the Senate Committee on Agriculture.
  - o OMB requests comments on the Kramer-Greenstein draft bill from HEW, Justice, Treasury, Labor, CEA and Postal Service.
- 8 FNS (USDA) distributes "Methodology for Estimating Impacts of EPR." Copy goes to OMB later.
- 9 Senator Talmadge writes Director Lance opposing EPR.
- o Ben Bailar (Postmaster General) comments to OMB on USDA draft bill. He opposes provision of expanded role for the Postal Service in distribution of food stamps.
  - o Secretary Califano meets with Secretary Bergland to discuss the food stamp proposal in detail. The two agree on the broad outline but Califano is emphatic that with the welfare reform plan imminent, he is not in favor of extending the program beyond two years (at this stage Agriculture plans for a four-year reauthorization period).
- 10 Richard Kasdan (ACTION) comments on USDA bill to OMB. He opposes the provision to count VISTA allowances in the gross income of applicants for the program.

- March 11 Greenstein writes to Kleinberg (OMB) discussing program costs of various options. He attaches studies by Peskin (HEW) and Hoagland (Congressional Budget Office) discussing the theory of consumer preference as it related to income supplements and food purchasing.
- o FNS distributes to OMB an analysis of S. 903 and S. 275 (the Humphrey and Talmadge bills).
  - o Daft (DC) calls an interagency meeting for the following Monday, March 14. Invited are representatives of HEW, USDA, Treasury, OMB, CEA, and DC. At this stage the food stamp program has several eligibility options, a four-year reauthorization period, EPR, and a provision to recoup the additional program costs through the income tax system.
  - o In preparation for the Monday meeting, OMB develops a detailed briefing book on the program and USDA proposals. This is done by Kleinberg, Vasquez, and Ostenso. Copies of the briefing book go to Suzanne Woolsey, Naomi Sweeney and Jeff Weinberg of OMB Legislative Reference Division, OMB, and Lynn Daft (DC).
  - o Kleinberg raises with Woolsey the range of budgetary threats posed by the current Food Stamp Program (FSP) options. He is concerned that the Monday meeting participants should argue issues within a realistic budgetary limit. This requires policy direction which is obtained by Woolsey from OMB Deputy Director McIntyre. He states that the cost of FSP will be limited to the level of current services. The OMB group goes into the Monday meeting with this policy position.
  - o Pat Wald and Ben Civiletti (Justice) comment to OMB on the USDA draft bill. They argue for improved fraud controls.
  - o Lyle Gramley (CEA) comments to OMB that the recoupment proviso is inconsistent with the Administration's goal of simplifying tax forms.

- o Secretary Califano calls Carp (DC) and suggests that he attend the Monday meeting. The Secretary is particularly concerned that discussion of the food stamp options be coordinated with the welfare reform plan on which Carp is also working.
- o Wendell Primus (House Agriculture Committee staff member) calls Greenstein to say that he has found a flaw in the computer programs he has been using to estimate option impacts in the food stamps proposal. The effect is to reduce confidence in the estimates of what the recoupment provision would save. In Greenstein's judgment, this, together with HEW's expressed opposition to the recoupment provision, significantly lowers the desirability of keeping the provision in the bill.

March 12

The Washington Post publishes an article disclosing that the Administration is planning to drop the purchase requirement. Chairman Foley (House Agriculture Committee) is furious that the plan had not been cleared with him in advance; to make matters worse, he finds that his own staff had been drafting the bill without his knowing and are quoted in support of EPR. He threatens to oppose the bill in the House - a position which Greenstein believes at the time would almost certainly have killed it. The Congressman calls a number of Administration officials at OMB repeating his opposition while Greenstein prepares to persuade him of the value of EPR. This is a major turning point in the fortunes of the food stamps proposal.

- 14 Interagency meeting. Attending are Henry Aaron, Michael Barth (HEW); Carol Foreman, Bob Greenstein (USDA); Emil Sunley, Lawrence Woodworth (Treasury); David Kleinberg, Joe Vasquez, John Ostenso and Suzanne Woolsey (OMB); Bruce Gardner (CEA); Frank Raines, Lynn Daft, and Bert Carp (DC). The principal issues discussed are budget impact, EPR, recoupment and the length of the reauthorization period. Agriculture agrees to provide additional cost and reliability data.

- 16 OMB elaborates options. At this stage there are seven options, and each is costed out to show winners and losers. Concern is expressed about the reliability of the method for estimating program impacts.

- o Greenstein meets with Sunley (Treasury) to go through the problems that both had been having with the recoupment provision. IRS officials make a presentation outlining the enormous administrative difficulties involved. Greenstein is persuaded that the provision is impractical and recommends to Bergland the next day that he drop it, which he does.

March

- 17 Greenstein sends memorandum to Carp, Raines and Daft costing out five program options without recoupment.
  - o The Department of Labor reports to OMB that it opposes the jurisdiction of USDA over the work requirement that is in the bill as a condition of eligibility.
- 19 Greenstein goes to Chairman Foley's home to brief him on the bill. He outlines the results of cost estimate studies and goes in detail through the case for EPR.
- 21 Secretary Bergland meets with Senator Talmadge and Congressman Foley. The Congressional Insight newsletter reports that the Congressmen said that they did not want to compromise on the lower price supports the Administration was planning if USDA pushed ahead with EPR. Other players say that no such linkage was ever raised.
  - o Carp is told by Greenstein to consider the effect of the current program options on the northeast region. Carp agrees to consider including a shelter deduction in the program to compensate for higher costs in the region.
  - o Eizenstat advises Agriculture to prepare a formal statement to define their concrete proposals. It is intended that the memorandum will be circulated by DC staff for comments by affected agencies.

March

- 24 Church organizations around the country cable their support for EPR to the White House.
- o Greenstein meets with Chairman Foley. The Congressman says that he has been convinced of the genuineness of the effort behind the bill, but stops short of offering his support for it.
  - o Greenstein then meets with Carol Foreman (USDA) and Mike McLeod, Staff Director of the Senate Agriculture Committee, to examine the Senate response to the bill.
- 25 Foreman sends memorandum to Eizenstat outlining the revised food stamp proposals, including in it the special deductions for shelter and child care.
- 26 Informal meetings are held Friday and Saturday. Included are Kleinberg (OMB), Hoagland (CBO), Primus (House Agriculture Committee staff), Merck (USDA) and Greenstein. The purpose is to test the reliability of the Transfer Income Model for estimating the impact of the program options on participation rates in the program, level of benefit and likely cost.
- 28 Gardner (CEA) writes a brief memorandum to Raines arguing for total welfare reform with cash-out of food stamps.
- o Califano writes Lance in favor of EPR and a two-year reauthorization period.
- 29 OMB staff prepare draft memorandum for Director Lance arguing in favor of EPR. This is held contingent on an acceptable level of budgetary threat. Cost is kept down by setting the standard deduction at \$80 and rejecting the special shelter deduction provision. The level of budgetary risk on current services level is estimated at between \$75-185 million and the memorandum recommends accepting the risk.
- o Secretary Bergland formally writes the President arguing in favor of EPR together with a shelter deduction provision.

- o Attorney General Bell notifies the President that Senator Talmadge is opposed to EPR.

March

- 30 Secretary Bergland has a breakfast meeting with Senator Talmadge and Congressman Foley. Talmadge attacks the cost figures for EPR and Greenstein replies with a 20-minute briefing of what Agriculture, CBO and other staff had agreed on as reliable estimates.
- o Raines asks Secretary Bergland to delay the date of his testimony on the Hill in order to gain time to clarify differences in the Administration's proposals. The date is postponed to April 5.
- 31 In a second letter to the President, Bergland defends EPR, but drops his shelter provision after his staff accept the arguments of other players.
- o A new draft of the Lance memorandum is prepared changing the agency's position. Standard deductions are retained -- raised toward \$100 -- but the purchase requirement is also retained. The shelter deduction is recommended for disapproval.
  - o Raines writes a memorandum to Eizenstat, and then to the President, favoring EPR among the several options listed. This is the cover decision memorandum and details all the still active proposals and incorporated agency comments on each.

April

- 1 The President lunches with Senator Talmadge who reiterates his opposition to EPR.
- o The President disapproves EPR as recommended in the Raines-Eizenstat memorandum, but indicates that he wants to have a meeting to discuss the issues with Bergland. Interpretations differ about the nature and meaning of the President's decision at this point. A meeting is scheduled for Monday, April 4.
- 2 Greenstein calls Parham (Watson's staff) to brief him on the situation and to ask Watson's support at the Monday meeting.

April 4 Cabinet Room Meeting. Attending are Eizenstat, Lance, Califano, Watson, Bergland, Foreman, Greenstein, Raines, and Moore. The President tilts at first to retaining the purchase requirement but then accepts EPR.

### 3. ANALYSIS

#### The Issues for Decision

The food stamps program (FSP) was originally intended to supplement the diet of people too poor to be able to afford nutritional adequacy. It has not worked out that way. Eligibility is broad enough to include those with assets and income considerably above the poverty line (effect of temporary unemployment). But in order to receive an allotment of food stamps, eligible applicants must pay cash down. This purchase requirement is high enough to limit the participation of those at or below the poverty line who cannot afford the outlay. Moreover, for those now participating, less than half the value of the stamps received is applied to food purchases as such; this has not made a noticeable improvement in the dietary standards of the poor, which have been steadily on the decline since 1950.

The Carter Administration is committed to integrated welfare reform but this will take time to implement, as well as budget resources which are not yet available. In the short term, there has been a strong demand from community and welfare groups, reflected in the Congress, for some measure of added benefit from the food stamps program; specifically, for elimination of the purchase requirement to broaden the participation of the neediest groups. There is a regional character to this problem. Regional disparities are naturally important political realities in Congress, and they affected the development of options in this case, principally the shelter deduction.

a. The Nutrition Issue

The first issue to be identified was the extent to which the program would remain oriented to nutrition and food purchase. Elimination of the purchase requirement (EPR) was a step towards abandonment of the original objective and final cash-out of the program as a pure income supplement.

This last step could be taken but only within the coordinated welfare reform plan. This was going much slower at HEW than the FSP was being redesigned at USDA. Meantime in Congress, several bills were introduced dealing with food stamps. Senator Talmadge's bill (S. 275) retained the PR; S. 845 and S. 903 were for EPR. A step towards EPR implied a major threat to the jurisdictions of the two Congressional Agriculture Committees, which at least Talmadge and possibly Foley wanted to preserve. The former counted on persuading Attorney General Bell and Director Lance to argue his view with the President; both did. Talmadge also argued the case directly. He said that EPR and the USDA program could lift program costs by as much as \$1 billion. At first the President was inclined to agree with him.

b. The Issue of Cost

This identified a second issue: How much would the Administration's program cost, and how reliable were the estimates on which its options were based?

All participants agreed that the program had to be compatible with the HEW Welfare Reform Task Force; many of them participated in the Monday meetings of that group. Strategically some players were after a higher level of benefit in the food stamp program so as to up the ante when welfare reform, as expected, cashed the program out. Other players sought to keep food stamp spending levels down, both to limit the pressure on the current budgetary deficit and to provide longer-term protection for the balanced budget when the full welfare reform program would be implemented. They reasoned that the lower the budgetary cost in the FSP now, the more resources the Administration might have with which to sweeten its welfare benefits later. Both strategies depended on accurate estimates of the costs of alternative options.

### c. Budget Options

Within the two strategies a further set of issues was identified:

- o Benefits in the current program could be increased and the overall (budgetary) cost enlarged.
- o Benefits could be increased but limited to those in greatest need with those least in need losing some current benefits and possibly their eligibility.
- o Finally, budget outlays could be reduced and benefits held constant or even improved somewhat -- anticipating the welfare reform plan -- with budget savings effected by simplification of the program and reduction in administrative costs.

These options were never openly debated. According to one view, the DC staff leaned toward increasing benefits and budgetary outlays, while OMB tilted against them in the opposite direction -- benefits could be increased but only if no further outlays would be required. According to a second view, there was never any question about increasing budget outlays; this issue had been settled by the time the February budget amendments had been released. Agriculture could have gone to the President for more money for the FPS, but had it done so it would have weakened the prior claim it had made for higher farm price supports, also part of the Farm bill. Then and later most participants were prepared to compromise on the budgetary outlay side of FSP to leave more resources for the price support program.

### d. The Budget Threat Again

What divided the participants were two final issues: Where and how to set the level of benefits? How to offset the costs of increased eligibility and participation? Note that at no stage was there disagreement among the EOP players about the desirability of EPR. Greenstein at USDA reassured them that the Senate would not support Talmadge, and after lobbying Foley in the House, he felt that EPR would probably pass there too.

The players also agreed that benefit levels should rise at the neediest, sub-poverty level of income if a device could be found to recoup benefits paid out above the poverty line. Such a provision was developed using the IRS and the annual tax form to require recipients to report the benefits received over the year. When annual income exceeded twice the level of eligibility, the benefits would be repaid.

There were many administrative and policy problems with this. In addition, it created tactical difficulties by adding jurisdiction over the program and the Farm bill as a whole to the Ways and Means and Finance Committees where the consequences for this and other Administration bills were unpredictable. The participants consequently agreed to drop recoupment after their meeting of March 14. What remained to be decided was how to keep individual benefits up and aggregate costs down. This was worked out principally through detailed costing of options that standardized and then raised or lowered the level of deductions from net income around the poverty line.

To ensure that the technical work was reliable, the major specialists met with Kleinberg and Ostenson of OMB to test assumptions and results of projections for the participation rates expected after EPR at each of the benefit levels proposed in the options. These meetings (March 25-26) concluded on general agreement that the budgetary threat implied in the Agriculture proposal was, at most, \$185 million.

Until the last week the participants managed to preserve substantial consensus as the program options were developed a step at a time. An exception to the policy of standardized deductions -- special provision for the relatively higher costs of shelter in the northeast -- had been raised by Greenstein, considered by Carp, costed and then discussed by all. It was proposed to the President in the first Bergland letter, then dropped after USDA adopted the prevailing view of the others. The trouble was, as everyone saw it, that one exception opened the door to too many others. A difference of view about the length of time the new program was planned to run was similarly brought within the broad consensus.

e. The Lance Position

On March 31, however, Director Lance decided against EPR, and redrafted the Presidential memorandum his staff had prepared for him. This underscored the Talmadge view, and said that although "this proposal makes sense, it will be difficult to sell politically, and I recommend against supporting it at this time."

In his review of the Domestic Council cover memorandum and of other decision papers on April 1, the President indicated his disapproval of EPR, but called for a meeting of the principal players the following Monday. The Lance memorandum created two issues for decision: Was the budgetary threat as great as Talmadge viewed it? The consensus was No. Secondly, was Talmadge's opposition enough to kill the program or the bill? Again the consensus was No. The President decided in favor of EPR, a two-year extension of the program, standardized deductions, and a poverty line cut-off for eligibility.

Findings

a. Coordination

EOP staff work made it possible to assess a very broad range of program options in terms of precise estimates of program impact and cost and clear budgetary guidelines. One or perhaps two Domestic Council staff, and two to three OMB staff were enough to direct and coordinate the entire process. At each stage, players were generally clear as to the issues requiring decision, the process necessary to reach a decision, the priorities guiding the process, and the loci of responsibility for bringing it to completion. The effect of the staff work was to reduce a very large number of options to the small and residual number on which there remained differences of view among the players. These the President alone was able to assess with an economy of effort, in a relatively short time.

b. Expertise Coverage

The effectiveness of the assessment of options depended on the availability of a high level of technical expertise, of familiarity with the program and of the capacity to manipulate the relevant data bases and computer programs that were available. Greenstein (USDA) had expertise in all aspects of the program (before his appointment to Bergland's office), and experts in USDA and outside were drawn into the process as needed. Executive Office staff coordinated this coverage but did not provide the basic analysis needed themselves.

c. Congressional Liaison

Assessment of congressional reaction was methodical and achieved by staff outside the Executive Office. Again, Greenstein's role at USDA was crucial. But the experience of Domestic Council staff (not in this case Moore's or Jordan's staff) in dealing with congressional staff and their tactical sensibilities in that area ensured that this process, paralleling the one that had been piloted by the Ford Domestic Council in 1975, would be more likely to survive.

In this context, according to Greenstein, the Washington Post disclosure of March 12 was decisive, because it made clear to Administration officials working on the plan that they had failed to consult the one man whose opposition spelled almost certain defeat for the bill - Congressman Foley. Though very damaging as it appeared at the time, the Post article initiated a process of meetings and consultations which effectively won Foley over.

4. BACKGROUND DATA

a. Presidential attention: The President read two staff memoranda plus attachments from Domestic Council; memorandum from Bert Lance; letters from Senators Humphrey, McGovern and Talmadge, and Secretary Bergland.

b. Cabinet attention: Issue discussed by Secretary Bergland at meetings of March 7, 14, 21, 28, April 4 and 11.

c. List of active participants in the decision process:\*

The President

Senator Herman Talmadge, Chairman, Senate  
Agriculture Committee

Congressman Tom Foley, Chairman, House  
Agriculture Committee

Bill Hoagland, Human Resources Division,  
Congressional Budget Office

Wendell Primus, Staff Member, House Committee  
on Agriculture

John Kramer, Staff Member, House Committee  
on Agriculture

Bob Bergland, Secretary of Agriculture

Bob Greenstein, Special Assistant to  
Secretary Bergland

Carol Foreman, Assistant Secretary, Consumer  
and Food Services, Department of Agriculture

Bert Lance, Director of OMB

Suzanne Woolsey, OMB

David Kleinberg, Chief, Income Maintenance  
Branch, OMB

Joe Vasquez, OMB

Stuart Eizenstat, Assistant to the President  
for Domestic Affairs and Policy

Bert Carp, Deputy Director, Domestic Council

Lynn Daft, Domestic Council

Frank Raines, Domestic Council

Lyle Gramley, Council Member, CEA

Bruce Gardner, Staff Member, CEA

Joseph Califano, Secretary of HEW

Henry Aaron, Assistant Secretary for Planning  
and Evaluation, HEW

Michael Barth, HEW

---

\* Defined as a player who interacts on the issue outside his/her agency or EOP unit more than once.

Lawrence Woodworth, Assistant Secretary for  
Tax Policy, Department of the Treasury  
Emil Sunley, Deputy Assistant Secretary  
for Tax Policy, Department of the Treasury

Jack Watson, Cabinet Secretary  
Jim Parham, Staff of Cabinet Secretary

---

TOTAL - 26

---

CASE STUDY : MINIMUM WAGE DETERMINATION

DECISION ANALYSIS REPORT

B. MINIMUM WAGE DETERMINATION

1. ABSTRACT

On March 24, 1977, Ray Marshall, Secretary of Labor, presented testimony regarding a bill (H.R. 3744) introduced by Congressman John Dent (Dem.-Pennsylvania) which would raise the minimum wage to approximately \$2.85 in summer 1977, and to approximately \$3.31 on January 1, 1978. This study describes and analyzes the decision process immediately preceding the Marshall testimony. It highlights the bartering process which necessarily results from initial differences in departmental positions, describes the relative contribution of several EOP units (i.e., CEA, OMB, Domestic Council) to the final discussions, and focuses directly on two particular issues: 1) the extent to which relevant expertise was applied; and 2) the extent to which the Economic Policy Group contributed to the decisionmaking process.

2. BACKGROUND

The earliest political contribution to the issue may have been provided at a lunch on March 4, at which the President was joined by George Meany and T. Donohue (AFL-CIO), Vice President Mondale, Secretary Marshall and Domestic Policy adviser Stuart Eizenstat. No minutes for the meeting are available, though it is reasonable to assume that minimum wage issues did come up.

On March 10, 1977, Bowman Cutter, Executive Associate Director for Budget, sent a memorandum to EPG coordinators Gould and Hessler, proposing inclusion of minimum wage legislation on the EPG agenda, and suggesting an "emergency meeting" during the week of March 12. Cutter had been alerted of this need by OMB Legislative Reference (i.e., Naomi Sweeney).

Written notice of the minimum wage issue appears again a day later in Schultze's Weekly Report of CEA Activities on March 11. The memorandum indicated that the CEA

was examining both farm price supports and possible changes in the minimum wage, and that early analysis suggested inflationary and unemployment effects from increases in the minimum wage.

EPG held its meeting the following week on Wednesday, March 16. The minutes from the meeting indicate that the issue would be brought up at the following Monday meeting (March 21). Given the fact that Secretary Marshall was to testify on Thursday, March 24, this discussion left little maneuvering time for senior White House staff.

a. Discussion Memoranda

On March 17, both CEA and DOL submitted memoranda to the EPG with respect to the minimum wage issue. The Marshall memo supported the Dent Bill with a four-page document, and appended tables indicating historical relationships between the minimum wage and average manufacturing earnings. The Marshall memo also took issue with CEA's interpretation of the same historical trends. Marshall's memo provided no option other than that provided in the Dent Bill, and was not specific with respect to the bill's particulars.

The CEA memo of the same date addressed the particulars of the Dent Bill, raised new options in a general way (e.g., split the minimum wage, and phase in indexing to some wage base), and discussed the negative economic impact of the bill in terms of inflation and teenage unemployment. The CEA memo also raised the option of not indexing minimum wage at all. This option was included at the suggestion of OMB's Housing, Veterans, and Labor Division (HVLD) (i.e., Tom Morgan) who argued in writing that (1) indexing wages but not prices introduces distortions, and (2) indexing may make inflation more palatable and therefore harder to control.

Morgan made similar arguments in his briefing memorandum to Director Lance on March 17. He listed all options available, and noted HVLD's recommendation of not indexing the rate, but raising it to \$2.65. According to Morgan, the \$2.65 rate would bear a 47 percent

relationship to average manufacturing earnings. (Actually it seemed closer to 50 percent, assuming a \$5.35 mid-1977 manufacturing earnings base. The percentage translation was handled differently by all participants, such that there was never clear agreement until the final decision as to what index percentage resulted from a specific rate increase.)

Morgan followed a day later with another memorandum to Lance commenting on Marshall's DOL submission statement of the 17th to EPG. He noted: (1) Marshall had discussed indexing to gross hourly earnings (including overtime), and that no minimum wage proposal raised this possibility; (2) the Dent Bill increases would be inflationary and destabilizing and that other DOL papers on unemployment insurance tax increases made the same point (contrary to DOL's minimum wage paper); (3) indexing to average hourly earnings is inflationary unless earnings increase at the same rate as productivity; (4) purchasing power increases may be overwhelmed by price increases; and (5) minimum wage compliance has not (contrary to DOL assertions) been very high, and DOL currently had a backlog of 40,000 complaint cases.

b. The EPG Meeting

The EPG met on Monday, March 21. According to one observer, the issue of indexing was raised, but was not discussed in terms of alternative index bases (i.e., CPI vs. manufacturing wages). The CEA position on indexing prevailed, and all participants (with the exception of Richard Cooper from State -- see below) agreed to it. As a consequence of that meeting, a three-page memorandum to the President was drafted for Secretary Blumenthal's signature. Blumenthal's memo to the President included two options: the first was the Dent Bill option, supported in the meeting by DOL and HUD, that included an immediate rise to \$2.70 and pegged future rates at 57 percent of average manufacturing straight time earnings. The second option was generated by CEA, and supported by Treasury, OMB, and Commerce. Whereas the first option could be considered responsive to Labor's position, the second option was definitely not: an immediate increase in the minimum wage from \$2.30 to \$2.40, and an indexing of the minimum at whatever percentage rate was indicated (the \$2.40 nominal rate translated into a peg at approximately 45 percent of

average manufacturing straight time). This options memorandum was supported by a CEA discussion paper identifying potential unemployment and inflationary effects.

c. Post Meeting Memoranda

The memo was sent to the President, but entered the Hutcheson paper pipeline and was routed in a normal manner to Eizenstat late on Monday, the 21st. Eizenstat then generated two new options, both of which fell between the DOL and CEA extremes. These two new options were combined with the two EPG generated options in an options memorandum submitted to the President on Tuesday, March 22.

In addition to the four options now available, the Eizenstat memo: (1) noted EPG's general acceptance of the concept of indexing (this acceptance was surprising, given the implications); and (2) raised an issue not discussed in the EPG meeting -- perhaps the peg should be to the CPI, not to average manufacturing straight time earnings. The memo did not note the distinct difference in the impact of the two pegs (i.e., the CPI moves upward more slowly than does average manufacturing earnings, and is therefore less inflationary). However, the issue was at least surfaced.

Three additional memoranda were submitted on Tuesday to the President: from Schultze, Marshall, and Eizenstat.

The Schultze memo identified the intellectual debate with DOL (i.e., disagreement over the employment and price effects) and came down heavily against the Dent Bill and DOL's position, but did not recommend any new options.

The Marshall memo held to the Dent Bill approach and included the following points: (1) CEA's peg (approximately 45 percent) was too low; (2) the DOL option (of \$2.70 and \$3.10) was appropriate; and productivity increases would counter inflationary pressures, thus washing out price effects. Appended to this memo was a 15-page treatise. The purpose seemed to undermine the Schultze position by questioning the methodologies employed by the economist whose research was used by CEA to support assertions of heavy impacts on teen-age unemployment. (It is uncertain whether anyone read this appendix at all; it seemed inappropriate to a Presidential options package.)

d. Meetings with the President

Given the lack of consensus apparent in the policy papers submitted to the President (i.e., (1) EPG's two options; (2) Eizenstat's four options; (3) Marshall's one option; and (4) Schultze's one option), a meeting of principals seemed useful, and was suggested by the Cabinet Secretary, Watson. The meeting was scheduled for the following day, Wednesday the 23rd, with Secretary Marshall and others.

Eizenstat was notified of the forthcoming Marshall meeting and on Tuesday afternoon prepared a brief "talking point" memorandum to the President suggesting that the President should (1) indicate support for the idea of indexing the minimum wage; (2) waffle with respect to a specific rate increase; (3) emphasize to Secretary Marshall the fact that he "should take an Administration position;" and (4) if pressed, the President might wish to discuss a phased increase in the minimum to \$2.54 in 1977, and \$2.80 in 1978 (i.e., pegged at approximately 53 percent of average manufacturing straight time).

On Wednesday, March 23, the President met twice on minimum wage. The first meeting (20 minutes) was at 9:45 a.m., with Representative John H. Dent (D.-Penna.); Robert Vagley, Director of the House of Representatives Subcommittee on Labor Standards; Valerie Pinson, a White House Associate for Congressional Relations; and Charles Schultze, CEA Chairman. Eizenstat joined the meeting at 9:55 a.m. The meeting had been scheduled (at Congressman Dent's request) by Pinson, and involved a full exchange of views which provided the President an additional political perspective on minimum wage. The meeting produced no decisions, nor was it intended to.

The second meeting (30 minutes) occurred at 4:00 p.m., and included the President, Secretaries Blumenthal and Marshall, Presidential Assistants Watson and Eizenstat; and Bill Johnson, an Eizenstat assistant. The Vice President knew of the meeting, but had a schedule conflict and could not attend.

e. The Decision

A decision was made by the President to go with the \$2.50 rate, with a request that details be worked out by the participants. The technical detail which remained

was the determination of the base period against which to index rate increases. The participants agreed shortly thereafter on a March-to-March base period, with a rate adjustment each July. In July 1977, the rate would therefore become \$2.50, and the index percentage would be established by matching that rate against March 1976-March 1977 average manufacturing straight time earnings. On the following day, Secretary Marshall testified in favor of the \$2.50 rate.

### 3. ANALYSIS

The minimum wage issue does not end with Marshall's March 24 testimony. Mark-up hearings have not been held since, and there have apparently been continuous discussions between Administration and congressional representatives to determine whether some flexibility exists in the President's position.

Nevertheless, the March 24 testimony established an Administration position. In that context, the decision-making theme becomes: Could the decisionmaking process have proceeded in some other manner as to further illuminate and expand the President's decisionmaking choices? The response has several components.

#### a. Unit Coordination

The case study indicates a reasonable identification of separate unit responsibilities until after the March 21 EPG meeting. Labor had presented its paper to the EPG, as had CEA. OMB staff had provided comments to Lance. Both the Labor and CEA papers were discussed at the EPG, and Blumenthal had summarized positions from that meeting in his options memorandum to the President. The memorandum also noted collective EPG support for the concept of indexing.

However, at that point, EPG as a coordinate process broke down. Secretary Marshall and CEA Chairman Schultze both felt it necessary to re-state their positions to the President; Eizenstat added two options himself; and all of the interested principals met the following afternoon with the President. The President, in effect, was compelled to "re-coordinate" the parties involved. (Given the importance of the issue, the President's participation at this point may have been inevitable.)

b. Over-Processing

Given the ongoing nature of the minimum wage issue, and the many additional meetings which have occurred, one might interpret the multiple activities as either commensurate with the complexity of the issues involved, or as the re-processing of static positions. Examining events up to March 24, the latter perception seems closer to the mark.

It is unclear, for example, whether the EPG performed a useful role with respect to the minimum wage. What went in (DOL and CEA positions) came out the other side without nuance, and with no expansion of Presidential options. The participants did agree on indexing, but questions remain: Should the implications of indexing have been more completely staffed out previous to the EPG decision? What would have been lost by establishing a rate increase first, and providing more time to examine the important implications of (1) indexing, and (2) the selection of alternative index bases, given agreement on the principle? This latter position was expressed by OMB HVLD, but apparently was not articulated by an OMB official in the EPG meeting.

Dick Cooper, Under Secretary of State for Economic Affairs, did apparently raise the index issue at the EPG meeting. If one indexes the minimum wage, he suggested, why not index other compensation systems, and perhaps more of the government's transfer programs? An interviewee who attended the meeting indicates, however, that almost all participants felt that indexing was useful, and would be a reasonable contribution to the labor movement, whatever the minimum wage rate. Schultze supported the index as a way to smooth wage adjustment patterns, and to increase the predictability of the rate adjustment process.

c. Expertise Coverage

Neither DOL nor CEA provided convincing material related to employment and price effects. This may be a failing of the data, not its analysis, but lacking convincing arguments, neither DOL nor CEA's option proved tractable. Moreover, both transmitted their technical arguments to the President in their March 22

memoranda, doing no more in the process than perhaps document the failure of the process to provide a common data base or a better clarified statement of technical dispute against which Presidential options might be discussed.

This problem may be dismissed by reason of (1) the newness of the participants to the process, and (2) the short time in which action was required (i.e., the Administration had been in office only two months). However, there was time to staff out three issues:

- o Indexing as a minimum wage policy, not merely as a concession (albeit reasonable) to labor.
- o The correct indexing base (i.e., CPI vs. average manufacturing straight time).
- o Political implications.

The first was discussed above. The indexing base issue was raised in the March 21 Eizenstat memorandum, but this occurred after the EPG meeting and does not seem to have been seriously discussed. "Political implications" were undoubtedly not ignored in the EPG meeting, yet the resultant EPG options memorandum afforded the President only corner (i.e., extreme) options. It fell upon Eizenstat to generate middle-range options for the President to review. (These options were gradations of the established extremes, not qualitatively distinct alternatives.)

It is, of course, possible to argue that EPG should not apply political perspectives to issues under discussion. If that approach is taken, however, two corollary procedures must apply or the process cannot be fully useful to the President:

- (1) The EPG discussion must be better staffed out with technical back-up (provided by CEA, lead agencies, and perhaps OMB).
- (2) The process must allow more time for the application of broader policy judgments by the Domestic Council, Congressional Liaison, the Vice President and the Hamilton Jordan group. Conversely, these latter

groups should be asked to provide systematic contributions to the decision process prior to convening EPG sessions. This suggests the early and formal involvement of the Domestic Council, and the imposition of some formal structure upon the collection and communication of "political" information to the decision process.

d. Focus of Administration Initiatives

DOL came down very hard in favor of Congressman Dent's Bill, and adhered to that position to the end of the process. However, having made his case and lost, Secretary Marshall did align himself with the "Administration position" in his testimony. In this sense, Presidential policy direction was appropriately reserved for the President. Conversely, constituency support was preserved by DOL.

e. Forecasting

The issue of outyear implications was raised above with respect to indexing. The greater the extent to which the Nation's multiple wage, salary, and transfer payment scales are indexed, the greater the extent to which the economic system provides its own economic "escalators." This is an important long-range issue, and deserves (deserved) a more long-term analysis. Moreover, indexing has direct implications for the Administration's anti-inflation package. The issue does not seem to have been addressed in terms of that larger consideration.

f. Organizational Interest

Although departments presumably must respond to their constituencies (i.e., organized labor here), should DOL have provided additional options to the White House? Marshall had three opportunities to do so, and in each case re-asserted support for the Dent Bill. Did DOL conceive their organizational interest too narrowly? If Cabinet government is to work well, it is reasonable to assert, one would think, that department policy support work must be comprehensive and high caliber. It is too much to ask of departments to expect them to enthusiastically support positions which are inconsistent with their

direct constituents' interests. It is not too much to expect each department to staff out alternative positions and their impact. Both DOL and CEA could have performed a more useful service in this respect. Given a natural propensity to espouse one's own position, the presentation of "non-preferred" options will only occur if demanded by a process approved by the President.

CASE STUDY: SOCIAL SECURITY FINANCING

DECISION ANALYSIS REPORT

## C. SOCIAL SECURITY FINANCING

### 1. ABSTRACT

On Monday, May 9, 1977, Vice President Mondale and HEW Secretary Califano announced a new Administration initiative to stem the depletion of social security reserve funds. Included was a long-term proposal to remedy a faulty inflation adjustment formula under which benefits were rising more rapidly than workers' earnings. Included also was a short-term proposal to channel an additional \$56 billion into the funds between 1978 and 1982.

This analysis treats the Economic Policy Group and its role in the decision on the short-term proposal. EPG entered the process late but met twice on the issue in April; the second meeting reached consensus on the long-term issue but generated three alternatives to the short-term proposal put forward by HEW, the lead agency. In the week after that meeting, the President received three competing decision papers, prepared by HEW, the EPG, and the Domestic Council. Only EPG presented the options in a way that left the President any real choice. The President selected the HEW option, working off the Domestic Council paper; a hastily-scheduled Oval Office meeting was then held the day before his London summit trip, at which he re-selected it, in slightly modified form. This case therefore highlights the problems of competition between EOP policy staffs, and the danger that advocacy within a staff can drive out objectivity. DC acted as a partisan for the HEW proposal; EPG staff was neutral but lacked the leverage to put the options it developed effectively before the President. The case also illustrates the limitations of a frequent EPG procedure to date--eleventh-hour review of a departmentally-generated proposal, with insufficient time left for developing fully-staffed alternatives.

### 2. BACKGROUND

There are three social security trust funds: for Old Age and Survivors Insurance (OASI); for Disability Insurance (DI); and for Hospital Insurance (HI). These funds are built

up when payroll tax revenues allocated by law to their particular programs exceed outlays; they are drawn down when the opposite is the case. The short-term problem is that the DI and OASI funds are being rapidly depleted due to recession-induced revenue declines and increases in the number of disability claimants. Under HEW projections, the DI trust fund will be exhausted by late 1978 or early 1979; the OASI trust fund will be exhausted by 1983. To allow them to come even close to exhaustion, officials fear, would undermine public confidence in the soundness of the system; hence legislative action is desirable this year, and key congressional committees are interested in acting. But President Carter came out against further increases in payroll tax rates during the campaign. And any proposal to reduce outlays by changing the benefit structure would be highly controversial, would probably require years of debate before enactment, and would have only a gradual impact on outlays once enacted. Moreover, Carter had also taken a campaign stand against "reducing the relative value of retirement benefits as compared with pre-retirement earnings."

Working within these and other constraints, HEW explored alternative remedies to the problem during the late winter and early spring. There was some Domestic Council involvement (Eizenstat and Carp provided in particular some background on the President's campaign stands.) and HEW Secretary Califano brought Schultze of CEA into some early discussions. But the analysis and debate were mainly intradepartmental. By mid-April, HEW had developed a proposal to bring about \$60 billion additional into the funds between 1978 and 1982, enough to keep reserves at an adequate level, mainly through two major program innovations:

a. Counter-cyclical general revenues: Whenever unemployment exceeded six per cent, the Treasury would transfer to the funds from general revenues an amount equal to the difference between what payroll tax revenues would have been at six per cent unemployment and the revenues actually collected. Made retroactive to 1975, this would bring an estimated \$14 billion into the trust funds by 1982.

b. Removal of the ceiling on earnings subject to the employers' (but not employees') payroll tax: If made effective in 1979, this increase would bring about \$40 billion into the trust funds without increasing future benefit obligations, which are tied to wage levels subject to the employees' tax.

There were also HEW proposals for raising modest additional revenues and shifting revenues among funds. And the two above had complications beyond what is necessary to describe here. What is important, however, is that both represented major departures in budgetary and taxation policy, with important economic implications. Thus as others in government learned of the dimensions of the HEW package, concern grew. In OMB and Treasury officials worried about impact of this step into general revenue social security financing for budgetary policy and tax reform. In those agencies and CEA there was concern also about the overall economic impact of the package, particularly the contribution of payroll tax increases to inflation.

### 3. ENTER THE ECONOMIC POLICY GROUP

It seemed to EPG Chairman Blumenthal and Executive Director Preeg that social security was an appropriate issue for their forum, so they sought HEW's agreement to its placement on the EPG agenda. HEW initially resisted, with the acquiescence (and perhaps the support) of the Domestic Council staff. To the Department, social security was clearly within their jurisdiction. They had done the analysis of the problem; they would have to carry the ball on Capitol Hill. HEW was not an EPG executive committee member, and was understandably reluctant to undergo the additional burden of review in a Cabinet-level forum dominated by others. Moreover, the EPG had a reputation for slowing issues down without always bringing important new information to bear on them.

Blumenthal persisted, and the issue finally was put on the EPG agenda for Monday, April 18. HEW was then slow in completing the paper which was to serve as the background for the meeting; it was finally distributed by EPG on Friday the 15th. Between then and the meeting, however, another social security issue moved into prominence - James Schlesinger was proposing that the energy program (to be announced on Wednesday the 20th) provide that receipts from the program's well-head tax be channeled into the social security funds.

HEW was alarmed. The amount provided would only meet about half of the short-term need, but the President apparently thought that the well-head tax would solve the social security financing problem and provide funds for other major proposals also, tying social security to the energy program, moreover, placed it in a different legislative framework, one over which

HEW would have only limited influence. Action on social security would become a function of how Congress viewed that particular tax and the energy program more generally.

There were intensive discussions over the weekend in which HEW worked to persuade the President, the energy staff, the Domestic Council, and others that the well-head tax would not solve HEW's problem.

When social security came to the EPG that Monday, the well-head tax predictably dominated the meeting. The discussion was not, apparently, very orderly--Secretary Califano arrived late, Schlesinger wandered out in the middle, and Chairman Blumenthal did not lead the discussion very effectively. EPG members spoke against the linking of the tax to social security, however, and a consensus decision was reached to go to the President with an urgent recommendation that he delete this provision from the energy package, which he did.

Social security was again placed on the EPG agenda for April 25, about ten days before the President would have to make a final decision. (Califano was to testify before the Ways and Means Committee on May 10, and the President would leave for the London economic summit on Thursday, May 5.) The revised HEW paper was circulated on the Thursday before, and it was of good quality, succinctly describing the problem and what the department proposed to do about it. It did not, however, include any other options for short-term financing. And between its circulation and the Monday afternoon meeting, HEW modified its proposal somewhat. Schultze had expressed concern to HEW Under Secretary Champion about the sharp economic impact of lifting the wage ceiling on employer taxes all at once at the beginning of 1979. Champion announced at the beginning of the EPG discussion that the proposal had been changed to phase this in over a three-year period. This reduced the revenues it would yield somewhat, and compensating adjustments were made in the rest of the HEW proposal to make up for the funds lost.

The April 28 EPG discussion of social security was well-focused and productive. Chairman Blumenthal was clearly well-briefed on the issue; HEW presented and defended its proposal ably; no unexpected "crisis" like the well-head tax matter intervened. Several alternatives to the HEW plan were put forward, including the granting of authority to the social

security system to borrow from the Treasury if necessary--thus reducing the need for substantial trust fund balances. Two options were argued with particular force. Commerce Secretary Kreps saw the employer tax increase as a departure from a long-standing, respected principle of equal tax liability for employer and employee. She also saw it as contributing to inflation and unemployment, as firms adjusted to the labor cost increase by raising their prices or cutting their hiring. She concluded it would be best to move to explicit general revenue financing commitment of up to one-third of total inflow into the funds (the 1/3-1/3-1/3 approach). The actual amount of tax revenues channeled into the system would be the amount required, beyond the counter-cyclical provision, to maintain reserve funds at the level the HEW analysis indicated was required. Schultze also endorsed the general revenue approach to meeting the entire shortfall, out of concern with the inflationary impact of HEW's employer tax proposal--which had not been part of the package when he had discussed the issue with HEW earlier. But he suggested a different way of doing so--linking general revenue contributions to medicare, since benefits for the hospitalization program, unlike the other two, were not a function of employee wages or contributions. Such an approach had been recommended by the most recent (1975) Social Security Advisory Council.

OMB was represented by Cutter; its participation in the meeting was limited to expressing general concern about budgetary implications and a desire that the President see alternatives.

As the discussion concluded, the Chairman stated that the HEW approach might well turn out to be the best one but that the President should have other approaches called to his attention. It was agreed that a memo should reach the President by Wednesday the 30th. There was jockeying among Eizenstat, Blumenthal, and HEW about whether EPG or HEW should draft it. It was agreed that the basis for the memo would be the HEW product plus the other options raised at EPG. Thus began a sequence of events that would generate three Presidential decision memos on the issue.

#### 4. THREE MEMOS

The first memo to be completed was HEW's, dated Thursday, April 27. It was a lucid brief for the department's proposal, giving the President a place to approve or disapprove it while consigning the options raised at EPG mostly to TAB C. The memo did not mention EPG. The descriptions of the CEA and Commerce options in TAB C were relatively straightforward, though HEW seems to have overestimated the maximum cost of the latter by upwards of \$40 billion. In presentation of the substantive issues involved, the HEW memo was, in this reader's judgment, the best of the three the President received--well-structured and informational.

The EPG memo was completed next, on Friday. It was apparently the only one where the drafter engaged in direct consultation with interested agencies to be sure their options were presented accurately. Indeed, it was necessary to convert the CEA and Commerce proposals from attractive verbal articulations to concrete proposals. CEA participated directly in the drafting process. Commerce did not participate, as EPG staff was unable to elicit a reaction to its draft language despite efforts to do so by phone. (Circulation of the draft outside the EOP was avoided for fear of leaks.) As EPG began to draft its memo, OMB staff began to press its objections to the HEW plan (not stated at the meeting); the result was development of a fourth option, essentially postponement of major action until the issue could be further studied.

The EPG memo provided minimal introductory briefing, moving almost immediately to the four options and going out of its way to give them balanced treatment. The HEW proposal (supported also by Treasury, HUD, and Labor) was listed first and given slightly more space, but otherwise there was no acknowledgement of HEW's lead role on the issue--the fact that the department has done the major analysis and would have prime responsibility on the Hill, and that the other options had far less staff work behind them. Instead, EPG misleadingly characterized HEW's option as one that had "emerged from EPG discussion." From the staff's vantagepoint, this was perhaps understandable--a good Group meeting had generated some clear policy alternatives, and EPG staff was seeking to develop an objective format which would win Cabinet and Presidential acceptance. Moreover, the meeting and the memo were the EPG staff's first real involvement in the substance of the issue. They were coming into it fresh; the other choices were clear, logical alternatives to HEW's; thus EPG staff would naturally tend to give them near-equal weight.

The Domestic Council staff had not, apparently, contributed to either memo, though EPG at least had invited them to do so. The DC social security specialist had become concerned when the EPG memo did not arrive by Thursday, but after it was transmitted the following day to the Cabinet Secretariat under Blumenthal's signature, it was routed as a matter of course to Eizenstat, who the President generally expected to "cover" memos on domestic policy problems. By Saturday, DC staff had completed its own memo of roughly the same length (6 pages) as those of HEW and EPG. Unlike the EPG memo, it opened with two pages of background information about the issue. It then gave a full page to HEW's short-term proposal, followed by brief paragraphs introducing-- and quickly dismissing--the three alternatives. There was "no chance" that the OMB option could win congressional acceptance; the CEA proposal had "not been fully developed or analyzed by others;" the Commerce proposal also had "not been fully developed." It then strongly recommended the HEW option. Unlike both the other memos, the DC memo did not even mention the primary objection to the HEW employer tax proposal raised in EPG - its inflationary impact! In fact, it did not link the Kreps and Schultze options to any specific problems these officials saw in the HEW plan; this had the effect of making them seem trivial, like ideas dropped without any serious purpose. DC did, however, declare in the opening paragraph that it was "unfortunate the EPG, which decided this was an issue it should take up, has presented no indication of the economic impact of these alternatives" (emphasis in original).

From the DC vantagepoint, EPG had insisted on entering the issue at the eleventh hour, taken too much time completing its paper, and then delivered a product which contained very little economic data to support the generalized economic concerns of its members and failed to provide adequate introductory briefing. EPG had not distinguished among the options by their degree of development, and had offered the President no recommendation. DC saw it as their responsibility to review decision papers coming to the President and write their own when another product was wanting (and, according to one senior DC staff member, they found such papers wanting in perhaps 75 or 80 per cent of the cases). If they found them adequate, they could instead cover them with a shorter memo highlighting the issues and conveying Eizenstat's recommendation.

The DC memo suggested that "a meeting be arranged" with the President the following week "to discuss these matters," and the DC staff apparently was responsible for soliciting the views of Robert Ball, former Social Security Commissioner, who had provided advice to Carter during the campaign.

The options memos went to the President in a package. The Eizenstat-DC memo was on top, Califano-HEW next. A memo from OMB on its position was third, and Blumenthal-EPG fourth. Fifth was a memo by Robert Ball. The DC staff apparently assumed Carter would read them all; he frequently did on important issues. But the President was preoccupied with his forthcoming trip. He read the top memo and checked the HEW option, making other notes to Eizenstat as well. He may have looked at the HEW memo; it is unlikely that he got as far down the package as the EPG memo. He wrote on top of the package: "Stu - set up brief meeting if necessary - I can't study this much. J." The memo was returned to Eizenstat for action May 2; that same day, CEA sent over a memo spelling out its position, which apparently did not reach the President until after he had acted on the package. Schultze argued that the HEW plan would increase employer payroll costs "by about 0.7 percent;" that "most of this increase will almost certainly be passed forward into prices"; that "such a boost in the inflation rate, when combined with the impact on prices from the energy program, will have a serious adverse effect on the economy."

EPG staff learned their memo had been buried when the package arrived back in Watson's office and Preeg received a phone call indicating that a decision had been made. To EPG, which had gone to considerable effort to establish a procedural understanding with Eizenstat on routing of EPG memos and felt that they were in agreement, this was a clear setback. How could the staff credibly negotiate with EPG members about the language for explaining their choices to the President if what the President acted on was different language entirely, differently slanted? When EPG protested what had taken place, Eizenstat was apparently conciliatory, saying that it would not happen again, suggesting that DC and EPG should work more closely together in putting together such papers in the future. He raised with Preeg whether he thought a Presidential meeting would be desirable. They agreed that one would, and he asked Preeg if he would arrange one. This Preeg quickly did.

The meeting was held the following Wednesday, May 4, the day before the summit departure. The major interested agencies were represented and Eizenstat and Preeg also attended. President Carter received a short briefing paper for the meeting from Eizenstat discussing only the HEW option. Other participants (including Eizenstat) received a paper from Preeg outlining all four options. The President, who seemed to know the subject matter very well, went around the room asking people's views. Califano defended HEW's proposal. Kreps voiced her option forcefully and at some length; Lance gave some support to Kreps, though the OMB option was in the opposite direction. Gramley

of CEA spoke for Schultze, who was keeping a previous commitment in Hawaii. Blumenthal explained that he favored the HEW option but most of his Treasury subordinates felt otherwise. Robert Ball explained his views. The President opted again for the HEW position, but this time with a modification proposed by Ball. The following Monday, the program was announced by Mondale and Califano and dispatched to Capitol Hill. Thus far it has had a mixed reception.

## 5. CONCLUSIONS

It is useful to begin with the obvious. The President should not, in any well-functioning system, be presented with three competing options papers, each written in the expectation that it will be his primary decision document, each giving the choices a different spin. In cases where alternatives exist, he should receive one basic decision memo. It should present options as fairly as possible, with all the important arguments and all the major information the President needs to make his decision. The advocates of differing choices should have confidence that the central decision memo will represent their proposals fairly. These advocates should be free to send their own memos developing their views at greater length, with the assurance that they will go to the President as attachments to the basic decision memo.

Putting together such a memo is a task that should usually be performed by an EOP staff--and it is one of the most important tasks of such a staff. On an issue like social security where more than one EOP staff has a claim to jurisdiction, there is no simple rule as to which one should do the job. In this case, EPG was the only staff which seriously sought to. It should have paid more obeisance to HEW's lead role and the fact that that department would have to carry the ball on Capitol Hill; it should not have suggested that the HEW option had "emerged from EPG discussion," though the employer tax provision was significantly modified during the EPG process. It suffered, apparently, from insufficient closeness to the President to reflect a feel for what he wanted in such a memo. Still, EPG's was the only memo which left the President any real choice; the DC memo was at least as much a brief for the HEW plan as the one drafted in the department, providing virtually no mention of the arguments developed in EPG against it. Unless the President had in fact already chosen the HEW approach and the DC staff knew it, their memo violated one of the oldest rules of White House staff work: that the President's ability to choose should be protected. Even if, as interviews indicate, the DC view was that the President's real choice was either to accept the HEW plan or to defer action, because of problems with that plan, until alternatives could be fully staffed and needed economic impact analyses completed, the memo should have been written so as to clarify this choice. It was not so written.

The DC staff admittedly plays another role for the President--providing advice on which course he should take. The President clearly wants Eizenstat to provide such advice. The danger is that advocacy can drive out objectivity--as clearly occurred here. But this is not inevitable if staff is self-conscious about playing both roles and about the tension between them, tempering its commitment to a particular action with a commitment to procedural fairness and a recognition of its strategic role in assuring such fairness.

EPG staff has a different sort of problem--it is poorly placed for making its memos the basic Presidential decision documents because it does not work directly for the President. The Executive Director is formally attached to the Cabinet Secretariat but reports in practice to Chairman Blumenthal. Established procedures put DC in the position of reviewing EPG's work on issues where Eizenstat is the President's substantive staff coordinator--and this includes all domestic EPG issues plus trade. His staff naturally considers that this makes them the broad policy brokers (though they do not clearly see themselves as neutral brokers), and they tend to cast EPG in a narrower, economic analytic role. They judge its effectiveness not on whether it develops new choices derived from the economic policy concerns of its members (which it did in this case) but rather on whether it contributes serious additional economic analysis to the issue (which it did not). By contrast, the EPG staff sees itself not as an analytic group but as brokers who help move economic issues forward for Cabinet consideration and Presidential decision.

What can be done? Already EPG has taken steps to prevent a repeat--gaining a recognition which it hopes will evolve into a procedural understanding, that such duplicative memo-covering is inappropriate and should not recur; there are suggestions (not apparently favored throughout the DC staff) that they should work together more on such memos in future. Certainly EPG cannot develop options papers effectively unless these papers become, with reasonably frequency, the President's real decision documents. One reason why EPG had difficulty communicating with Commerce to clarify its options, presumably, was that its staff role as options-presenter was not yet sufficiently recognized and accepted. The question is whether any DC-EPG procedural understanding will survive serious jurisdictional disputes between them, or occasions when an important DC staff person considers the EPG product inadequate. Under current staff arrangements, EPG cannot be the Presidential broker on a domestic issue unless DC accepts this role as legitimate generally and goes along in the particular instance as well. Such cooperation is made more difficult to the degree that DC staff regard frequent Cabinet-level setting of issues as a bad procedure (e.g., as development of frivolous options by people too high-ranking to understand the details), since for the EPG staff such discussions are its primary raison de'etre.

This last point is related to a broader conclusion about the EPG process--that discussion at the principals' level just before an issue goes to the Oval Office is unlikely to produce strong alternatives to the course a lead agency wishes to pursue. The EPG meeting on social security was an exceptionally good one, by all accounts. But real interagency consideration should have begun weeks earlier at the subcabinet level. The Commerce and CEA options which popped out on April 28, and the OMB option developed the day after, should have been surfaced earlier and presented in writing to the subcabinet and then the Cabinet level so that they could undergo the same scrutiny that the HEW proposal did.

The EPG staff recognizes the need for better subcabinet consideration of economic issues before they come to the Roosevelt Room on Monday afternoon. But setting up ad hoc working groups for particular issues and making them effective is far more difficult than getting an issue onto the agenda of the EPG itself. If the lead agency resists and the relevant EOP staff closest to the President acquiesces in this resistance--as would almost certainly have occurred on social security--real dialogue at this level is most unlikely to come about. Again the need that emerges clearly is to relate EPG staffing more closely, more cooperatively, to EOP staffing for the coordination of economic issues generally, whether they are handled in the formal EPG or not.

DECISION ANALYSIS REPORT

CASE STUDY: RURAL TELECOMMUNICATIONS TESTIMONY

## H. RURAL TELECOMMUNICATIONS TESTIMONY

### 1. ABSTRACT

This is a case study of current Administration policy in the area of enhancement of telecommunications services to rural areas. The position of the Administration had been requested by the Senate Subcommittee on Communications of the Committee on Commerce, Science, and Transportation, chaired by Senator Hollings (D.-So.Carolina). The Administration's position was presented at public hearings held by that Subcommittee on April 6, 1977, by Dr. William J. Thaler, Acting Director, Office of Telecommunications Policy (OTP).

A decision was handed down to Dr. Thaler from the White House, through the Domestic Council, not to commit the Administration to any specific activities with respect to rural telecommunications, particularly those activities that involved initiation of new programs and additional expenditure of funds. Rather, the Administration wanted to take a limited position on support for an interagency committee to examine options for delivery of telecommunications services to rural areas, including the possibility of a rural telecommunications demonstration program. The initial agencies designated for this committee included OTP, Department of Agriculture, Department of Commerce, HEW, and the National Science Foundation (NSF).

This case study is an examination of: (1) the events leading up to the April 6 testimony (particularly the period from December 1, 1976, through April 6, 1977); (2) a brief look at what has happened since; and (3) a background summary of the activities of OTP and other entities in rural telecommunications prior to the December 1, 1976, date. The December 1, 1976, date was chosen as a start point because it was the first documented activity by OTP on the rural telecommunications issue after the Carter election (see Chronology).

This case study is useful to

o show very succinctly one of the processes within EOP for the development of Administration testimony;

o indicate the relative lack of involvement at the higher levels within EOP of formulation of this Administration policy;

o the non-Presidential nature of the decision itself; and

o highlight in a direct way, an example of the problems associated with EOP line-staff relations.

## 2. CHRONOLOGY

OTP released a contracted study, "Pilot Projects for the Broadband Communications Distribution System." The study was intended to identify new broadband services which might be offered on a pilot or experimental basis. Of particular interest were programs which "involve extensive wiring of several diverse communities including rural areas." The study recommended that OTP act as a coordinator between government and private industry in fostering the initiation of broadband programs. In light of this recommendation, Vince Sardella, an OTP staff member, prepared a work statement for rural broadband system design and cost analysis contract studies in October 1972. These study contracts were subsequently awarded to the Denver Research Institute in January of 1973. It should be pointed out that the impetus for OTP involvement in rural telecommunications at that time also came, in part, from preliminary recommendations of the Cabinet Committee on Cable Communications. That Committee recommended the establishment of new regulatory guidelines which would "assure that basic cable or other broadband communications are available to residents of rural areas."

It was in the contracted Denver Research Institute studies that the FCC regulatory barriers to rural telecommunications service enhancement, cited by Dr. Thaler in his April 6, 1977 testimony, were first documented by OTP. However, these study results were debated within OTP management for over nine months. The point is that parts of the Thaler testimony reflected a relatively informed judgment on the part of OTP as to the regulatory barriers that needed to be removed for adequate telecommunications service to residents of rural areas in America.

On February 13, 1975, OTP released the Denver Research Institute studies. Around that same time, Acting Director John Eger sent a letter to FCC Chairman Richard Wiley summarizing the results of both studies, and suggesting that the FCC reexamine the cable-translator cross-ownership ban and prohibitions against use of FM microwave by translators.

Early in 1975, the Congressional Office of Technology Assessment (OTA) also undertook its own study of broadband telecommunications for rural areas at the request of Senator Talmadge (D., Georgia), Chairman of the Senate Agriculture and Forestry Committee.

In April 1976, OTP sponsored a Telecommunications Policy Research Conference at Airlie House, with one of the sessions devoted to Rural Telecommunications. Participating in this session was the staff who undertook the OTA study. The OTA study reaffirmed the position that had been taken by OTP in the past, but as the Acting Director of OTP indicated in a letter to Senator Talmadge, OTP felt that the study did not adequately recognize the range of costs and services options available to rural areas.

In October 1976, OTA sponsored a conference on the "Feasibility and Value of Broadband Communications in Rural Areas." OTP was a key participant in this conference.

Vince Sardella, of OTP Planning and Policy, prepared a memorandum for OTP Director Tom Houser which summarized the October OTA conference on rural telecommunications. Sardella's memorandum focused on the key recommendations of the conference which was "a carefully considered, but immediately initiated program of telecommunications demonstration projects in rural areas. The leadership and coordination of this, and possibly other similar new communications policy ventures, would be a special assistant or special adviser at the White House.... perhaps....the new Director of the Office of Telecommunications Policy."

Sardella also went on to suggest even further evaluation of this issue by OTP (above and beyond the Denver Research Institute studies).

On January 19, 1976, another memorandum, prepared by Sardella and Roland Heard, on loan from the Rural Electrification Administration, was sent to OTP Director Houser. The subject matter was proposals by the National Telephone Cooperative Association (NTCA). The telephone cooperatives had been heavily lobbying OTP's Houser to support their (NTCA's) petition to the FCC to waive FCC Rules 47 CFR 63.45, 64.601 and allow cross-ownership to provide CATV service to rural areas. The Sardella/Heard memorandum suggested that Houser send a letter to FCC Chairman Wiley, stating the views of OTP in regard to the NTCA petition. The memorandum also appended a draft of the letter to be sent.

On that same day (January 19, 1976), the draft letter was forwarded from Houser to FCC Chairman Wiley. Also that day, two additional letters were sent by Houser to Senator Talmadge, Chairman of the Senate Committee on Agriculture and Forestry, and Mr. C.R. Ballard, Assistant Administrator, Telephone, Rural Electrification Administration, respectively. The letters enclosed the NCTA position and indicated OTP's continued support of and interest in rural telecommunications services. However, Houser did not indicate that the positions espoused by OTP were anything more than OTP positions. These were clearly not those of the President, for there was no contact and no apparent awareness by President Ford (in his last day of office) of this activity. In addition, Houser neither indicated that he was speaking for the Administration, the Executive Office of the President, nor the Executive Branch. Yet, a position was taken by an EOP unit on a substantive matter with a regulatory agency (FCC), the Senate (Talmadge) and the executive branch unit in question (REA/DOA).

The important point is that the basic OTP position has not changed. However, the Thaler testimony represented for the first time in the rural telecommunications issue, the clear use of the terms "Administration" and "executive branch" in outlining the positions that OTP had taken.

Part of the explanation for this nuance of terminology can be found in a memorandum dated February 7, 1977, to the President from Stu Eizenstat and Rick Neustadt, Deputy Special Assistant to the President, Subject:

"Supervision of Office of Telecommunications Policy (OTP)."  
Neustadt had been a member of the Carter Transition Team during which he focused on telecommunications matters. The brief memorandum read as follows:

"OTP is an agency in the Executive Office of the President responsible for advising and representing you on communications policy. Its Director has resigned, and no new appointment has been recommended because it may be reorganized. However, OTP's Acting Director is now seeking guidance and supervision. Since the Domestic Council supervised OTP in the past, I recommend that we now supervise it until you decide the reorganization question."

The day-to-day policy responsibility for OTP was then delegated to Neustadt and it is under this stewardship arrangement that the rural telecommunications testimony was prepared. As part of his delegated duties as "de facto policy steward" of OTP, Neustadt prepared a memorandum for Eizenstat, through Si Lazarus and Bert Carp, outlining the communications policy activities in which he felt the Administration should become involved.

In an introductory paragraph, he clarified the actual nature of the mode of operation for OTP, that the White House was to use over the next few months:

"I suggest we launch the following projects. OTP would do much of the work, at least until its organizational status is settled. (OTP will remain in existence until at least July.) I would supervise, working with Si and Steve Simmons."

This memorandum, along with the memorandum to the President of February 7, indicates that the line-staff relationship between OTP and the White House was not strictly adhered to. It appears inappropriate for a White House staff person to suggest personal supervision of a statutory office within EOP.

Neustadt's comments in the memorandum with regard to rural communications was:

"Senator Talmadge is about to propose a Federal demonstration program of social service delivery in rural areas via telecommunications cable, satellite, and/or broadcast. This scheme has been developed by the Office of Technology Assessment and has mounting support on the Hill. Key issues are how much to spend and what agency should run it. We should study whether to support such a program and - if so - how it would work. (The Secretary of Labor has indicated he wants to be involved in this.)" Neustadt did not indicate, however, whether "we" meant Neustadt and Eizenstat, the Domestic Council or OTP.

On March 18, 1977, Senator Hollings' Subcommittee on Communications requested by telephone, that the OTP Director testify. This request was followed by a letter from Senator Warren Magnuson (D., Washington), Chairman of the full Committee. At the same time, OTP began pulling together material in anticipation of the testimony to be prepared. March 25, 1977, a draft options paper for the testimony was given to Neustadt. On Monday, March 28, Neustadt indicated to Thaler that he generally agreed with the recommended options. On that same day Neustadt sent a revised two-page memorandum to Eizenstat which incorporated much of the reduced Sardella options paper and made the following recommendations for Eizenstat's approval:

- o Press for relaxation of FCC restrictions affecting rural areas.

- o The Administration would create a planning group which would evaluate whether a Federal program is needed, how it would work, and whether State or private funds are available to support research on rural telecommunications.

Copies of this memorandum were sent to Thaler with an instruction to begin drafting testimony. Copies were also sent to Si Lazarus and Steve Simmons of the Domestic Council staff. It should be emphasized that the recommendations made in this memorandum are ones that the executive branch had supposedly been supporting for the past four years.

On Tuesday, March 29, Neustadt sent another memorandum to Thaler with several additional suggestions as to the shape of the needed telecommunications testimony. The key suggestions were:

1. Avoid discussion of the Bell bill;
2. Include a quote from the President indicating his commitment to improving rural life; and
3. Proceed on the assumption that Eizenstat would approve the Neustadt memorandum of March 28.

Neustadt further asked that a draft be ready by Friday, April 1. That same day, Neustadt asked by telephone, that Thaler coordinate OTP's position with REA and NSF "so that the Administration's position is consistent." Thaler responded affirmatively the same day to Magnuson's invitation to testify, and gave Sardella the responsibility of drafting the testimony.

On Thursday, March 31, Sardella hand-delivered a draft of the testimony to Airlie House, where Thaler, Neustadt, and Gregg Skall, OTP General Counsel, were attending the Annual Telecommunications Policy Research Conference. This group went over the draft in detail, with Neustadt doing the final re-write.

On Friday, April 1, Eizenstat (through Lazarus) responded to the Neustadt memorandum of March 28 approving the position, but with an emphasis on not committing to any spending program. Neustadt relayed this information to Gregg Skall at OTP. That same day, Skall and Sardella discussed the testimony with Sam Williams, OMB budget examiner for OTP. The purpose and result of the discussion was to make sure that, in no way, did the testimony imply unauthorized expenditure commitments by the Administration (or OTP) for the rural telecommunications effort. April 2, copies of the testimony were delivered to the Senate Subcommittee staff. On April 6, Thaler gave the Administration position on rural telecommunications in testimony to the Senate Communications Subcommittee.

April 15, as follow-up to the April 6 testimony, Thaler sent letters to the Secretaries of Agriculture, HEW, Labor, Commerce, and the Acting Director of NSF asking for an interagency committee contact for each Department to be named within two weeks.

### 3. ANALYSIS

The following is an analysis of the relevance of this case study to an examination of the problems and process of decisionmaking within EOP. This case study is interesting in that it provides some indication of both the decisionmaking process at work and the problems associated with the way in which the decision was arrived at, the actors involved, and the questionable value added of staff undertaking line responsibilities.

#### a. Unit Coordination

To the extent that coordination among EOP units was necessary in this case study, there seemed to be no major problems. OMB was brought in for review of the testimony at what seemed an appropriate time and again the Presidential memorandum sign-off virtually assured continued White House and Domestic Council involvement. However, the question is: was such coordination within EOP between Domestic Council staff and OTP in particular necessary at all? Was this an EOP (and therefore "Presidential") policy issue? It appears not to have been.

#### b. Delegation of Authority

The delegation did not necessarily follow the prescribed lines of authority. The memorandum signed by the President, giving the Domestic Council virtual control over OTP, is a partial explanation of this situation. In an interview, Neustadt indicated that he has tried to intervene as little as possible in the hierarchical structure of OTP, but when an issue of importance arose, he had no compunction about going straight to the person that could best address the issue.

Again, it seems inappropriate for White House staff to involve itself so deeply in the administration and personnel of another unit within EOP.

c. Over-Processing and Filtering

Prior to December 1, 1976, there was extensive over-processing with OTP's original decision (or position) not changing for over three years, but with continued reclarification of this position by, and to different individuals. Each time the position was reclarified, it was treated as a new decision or position of OTP. Thaler's testimony merely reiterated the basic position of OTP in 1973. As far as filtering goes, nothing filtered up prior to the involvement of the White House.

d. Expertise Coverage

Throughout this case study, OTP demonstrated a somewhat ponderous capability for bringing in the appropriate expertise on the rural telecommunications issue. This includes contracting out of relevant research, development of, involvement in, and attendance at the conferences and forums on the issue, and discussions with key individuals both inside and outside the government. Furthermore, once the information came into OTP, a slow but adequate synthesis was made in translating the material and data into policy relevant options.

This point raises other questions: should OTP be in the business of contracting research, sponsoring conferences, and otherwise synthesizing the opinions of the telecommunications community at large? Could this have been done by NSF? The fact that results of contracted research are often so slow in formulating EOP policy positions might suggest that such research should not be contracted by EOP units. Instead, outside entities like NSF, which are mandated to examine long-range implications of such issues might better perform the work.

e. Line-Staff Relations

The relationship between a White House member and the line organization was too close in this case study. A Presidential memorandum was approved giving oversight responsibility to the Domestic Council. This delegation of responsibility was interpreted as supervisory in the sense that the Acting Director of OTP began reporting directly to a Deputy Special Assistant in the Domestic Council. The arrangement was understood as being temporary, in order to allow OTP to function while awaiting the EOP Reorganization Study. However, it has probably gone on

too long. There seems to be little justification for Domestic Council staff assuming such line responsibilities, especially in a matter with such non-Presidential implications.

CONFIDENTIAL

DECISION ANALYSIS REPORT

CASE STUDY: WIRETAP LEGISLATION

~~CONFIDENTIAL~~

E. WIRETAP LEGISLATION

1. ABSTRACT

This case study examines the decisionmaking process leading to the submission by the Department of Justice of a bill that would "amend Title 18, United States Code, to authorize applications for a court order approving the use of electronic surveillance to obtain foreign intelligence information." If enacted, the proposal would...establish statutory limitations on the authority of the Executive Branch with respect to the collection of foreign intelligence information by means of electronic surveillance when the surveillance is conducted in the United States. Generally, it would permit such surveillance only in those areas in which approval has been obtained from one of seven district judges designated by the Chief Justice of the Supreme Court. "The measure would require that an affiant seeking an order to conduct electronic surveillance would be required to establish by sufficient facts, probable cause to believe that the intended target of the surveillance was a foreign power or an agent of a foreign power." The effect of this legislation would be that, in that area of electronic surveillance described above, the judicial branch of government would serve as a countervailing force against potential misuse of surveillance power by entities within the Executive Branch.

This issue has been a controversial one even prior to the Carter Administration and there was electronic surveillance legislation pending in Congress as the current bill was being drafted. As a result, to identify a precise date for the beginning of a detailed chronology of events is difficult. Furthermore, there has been activity, both of a formal and an informal nature, since President Carter first took office. Therefore, while we use February 22 as the date on which Presidential Review Memorandum-11 (PRM) of the National Security Council was introduced, as a start

~~CONFIDENTIAL~~ GDS (Declassified on December 31, 1983)

*Jy 5/1/87*

point in our examination of the decision process, this case study contains a brief discussion on activities prior to that date. The end date for the case study is May 18, the date that the Attorney General officially submitted the bill to Congress.

## 2. BACKGROUND

Under the Ford Administration, Attorney General Levi submitted a bill which had roughly the same intent as the current bill, but with some limitation on the court order requirement. (The current bill would require court review of proposed electronic surveillance in all cases.) Both the Senate Judiciary and the Senate Intelligence Committees approved the Levi bill last year but the measure got no further in Congress at that time. However, the bill did have the general support of Kennedy, Bayh, and Inouye, who are expected to also be the principal supporters of the current legislation.

Shortly after the Presidential election, the OMB Legislative Reference Division indicated to both President Ford and President-elect Carter, the status of legislative initiatives that were currently pending on the Hill. Included among the bills was the Levi version of the foreign intelligence electronic surveillance measures. Attorney General Bell initiated activity on a new version of the legislation shortly after he was confirmed. Informal discussions were being held in the Special Coordination Committee of the NSC as early as the end of January.

On February 16, Justice held two briefings. The first was with the intelligence community consisting of representatives of DOD, CIA, State and NSA. The second briefing was with staffs from both Houses of Congress who had a previous interest in the foreign intelligence electronic surveillance bill. The purpose of these briefings was to set the stage for a redraft and submission of legislation in this area by the Carter Administration.

## 3. CHRONOLOGY

On February 22, PRM-11 was issued directing the NSC Special Coordination Committee to review the overall intelligence structure and mission. As part of this directive, the Attorney General was asked specifically to look at the electronic

~~CONFIDENTIAL~~

99

surveillance legislation. On March 4, in a memorandum to all parties involved, Attorney General Bell created a legal working group of the NSC Special Coordination Committee under Acting Assistant Attorney General Harmon, composed of DOD, CIA, OMB, NSC, and State. Neither the Counsel to the President, the Domestic Council, nor the Office of Telecommunications Policy was involved in the working group set up by Justice. On March 9, the first meeting of the working group was held at the Department of Justice. A document entitled "Proposed Agenda Assignments and Deadlines for PRM-11 Subcommittee" had been prepared by Justice and was distributed and discussed at that meeting. March 23 was cited as the target date for distribution by each subcommittee member of comments on options in the draft bill.

During this time, there were two related drafting efforts going on at Justice. First, the issues and options surrounding the bill which constituted the working papers and actual end-products of the NSC Special Coordination Committee's working group were being prepared. Second, Justice, as a result of these working papers, began developing draft legislation.

At a meeting of March 18, Justice presented an options paper to the NSC Special Coordination Committee working group for comment. On March 23, at a working group meeting, OMB and DOD submitted their written comments on the Justice options paper. Another meeting was set for March 25, and at that meeting Justice added its written comments. By this time, Justice had developed a first draft of the electronic surveillance bill which was presented at the March 25 meeting. It should be emphasized that during this period, there were almost daily meetings of the working group as well as any number of telephone contacts between the parties.

On March 30, Justice presented the working group a final draft on the issues and asked for comments by the following day. Meanwhile, DOD provided written comments on the draft bill itself that had been received on March 25.

~~CONFIDENTIAL~~

~~CONFIDENTIAL~~

100

On April 1, another meeting of the working group was held to discuss the draft issues paper. CIA and State written comments were submitted at this time. As a result of this meeting, Justice agreed to make certain amendments to the issues paper, and on April 4 these amendments were distributed to members of the working group with a request for immediate telephonic approval. On April 8, the OMB staff members involved in the working group (from the National Security Division/Intelligence Branch) provided comments to OMB Associate Director Cutter and Director Lance as to the status of this issue.

On April 11, Justice distributed a "final" version of the issues paper along with an executive summary of the issues. Justice's position on court ordered warrants was reiterated and the Justice Department began soliciting support for its position on that issue. In fact, positions began to solidify around the issues at this point with Justice and DOD coming out on different sides in a number of substantial areas,....particularly, the geographic scope of the legislation and the inclusion of NSA domestic surveillance operations.

Justice began seeking support from within the Administration (notably OMB's Cutter and the Vice President's Office). The following day (April 12), Justice distributed its latest draft of the legislation to members of the working group. Again, one of the major areas of contention in both the issues paper and the subsequent legislative draft prepared by Justice was the geographic scope of surveillance to be covered under the bill. Thus, on April 13, Justice submitted a memorandum to working group members indicating that the proposed legislation did not cover electronic surveillance abroad. The next day (April 14), DOD sent a memorandum to Justice outlining current NSA surveillance activities and the implication of the proposed legislation of these activities.

Also on April 14, the full NSC Special Coordination Committee met to consider the Department of Justice's issues and options paper and the draft legislation. OMB's representative did not attend this meeting. However, OMB Associate Director Cutter personally phoned key NSC staff in support of the Justice Department's position on court order warrants and their geographic scope. The Vice President attended this meeting.

~~CONFIDENTIAL~~

~~CONFIDENTIAL~~

101

At this NSC/SCC meeting, the Committee gave approval of the working group's recommendation that the bill be confined to electronic surveillance within the United States. The Vice President agreed to this, provided separate legislation was developed covering electronic surveillance operations overseas. On that same day, the Vice President sent a memorandum to the President expressing concern and interest in the electronic surveillance legislation and basically supported the Attorney General, suggesting that legislation on overseas surveillance should be prepared but should be separate from the present legislation.

It was around this time that direct Presidential involvement became evident. Between April 15 and April 19, there was a series of correspondence and contact between the President, the Vice President, NSC, DOD, and Department of Justice, which apparently resulted in some, at least temporary, consensus as to Administration position on electronic surveillance legislation.

On April 15, Justice presented another draft of the legislation and forwarded to Brzezinski a memorandum on the issue of whether warrants should be required for domestic NSA operations. Justice came down in favor of such warrants while DOD wanted such authority limited. Again, Justice and DOD disagreed on a matter of substantive importance to the legislation, and the Attorney General indicated to DOD that it could make its own opinion known to the President. In fact, the President had already requested to hear the DOD side, for he had made a margin notation on the April 14 memorandum asking Brzezinski to "get Harold's (Secretary of Defense Brown) position."

On April 15, both the Deputy Secretary of Defense and the Attorney General wrote the President on the subjects of judicial control of electronic surveillance and the Justice options paper, respectively.

The Secretary of Defense followed on April 16 with a memorandum, in direct response to a request from the President the previous evening, outlining the DOD position. The April 16 memorandum for the President from the Secretary of Defense was returned to the Secretary by Brzezinski's

~~CONFIDENTIAL~~

~~CONFIDENTIAL~~

102

memorandum of April 20, with the following notation by the President: "(a) warrant for United States citizens overseas, (b) no reason for warrant for foreigners if incidental information on U.S. citizens constrained by 'minimization'."

On April 19, Justice sent to DOD a "final" version of the draft bill for comments. Three days later, on April 22, Assistant Attorney General Harmon distributed to the working group the revised draft bill "reflecting the President's decisions" on the key issues. On April 25, Brzezinski sent out a confidential memorandum to DOD, State, CIA, Justice and the Vice President. Its intent was to clarify Carter Administration policy vis-a-vis foreign intelligence electronic surveillance. This memorandum reported, in part, that the President had decided that warrants will be required "for all electronic surveillance within the United States, including foreign powers."

On that same day (April 25), Acting Assistant Attorney General Harmon telephoned OMB requesting quick clearance of the final version of the bill. The next day (April 26), both OMB and the working group received the draft bill from Justice for final comments. These comments were obtained and incorporated in the version of the bill that was sent to OMB, NSC/SCC working group, Treasury and Lipshutz's office on April 27.

Also on April 27, the President sent a handwritten note to the Cabinet and other officers expressing concern over "the confusion that exists in identifying a single spokesman in the Administration for major issues." (This note was to be the basis for a more formal memorandum from the President on May 4.)

On April 29, DOD submitted 25 pages of objections to Justice with copies going to OMB and NSC. After the DOD comments were received, there was a telephone conference between DOD General Counsel Deanne Siemer, Assistant Attorney General John Harmon, Special Assistant to the Attorney General Frederick Baron and other Justice staff members. Justice accepted DOD proposed changes in a number of areas and agreed to provide a written response with respect to the issues remaining outstanding. Several of these matters were issues only because Justice perceived the DOD proposals to be unacceptable to Senator Kennedy. The DOD

~~CONFIDENTIAL~~

~~CONFIDENTIAL~~

103

General Counsel sought and received concurrence of the Justice representatives for a personal contact between the Secretary of Defense and Senator Kennedy to find out whether there remained any room for compromise. On April 30, Justice responded with its own 12-page "comments on comments" to the Department of Defense General Counsel. During this period, Justice was having daily sessions with Hill staffers on the details of the legislation and the strategies for early passage--a step that is not usually taken in submitting Administration legislation. This Congressional contact was made known by Justice to all parties involved early in the working group sessions. The issues raised by DOD and Justice ranged from disagreement on broad policy questions to substantive disagreement on word usage.

Once it received the Justice response to its comments, DOD initiated a series of telephone communications with Justice regarding specifics of the draft bill. On April 30, and again on May 3, the Secretary of Defense and the Attorney General discussed the proposed legislation. No accommodation was reached. On May 2, Secretary of Defense Brown forwarded a letter to the President stating DOD objections. With the concurrence of DOD, this letter was held by the NSC staff for a short time to explore, once again, the possibility of compromise. On May 3, Secretary Brown telephoned Senator Kennedy and discussed the remaining problems with the bill. On the morning of May 4, Secretary of Defense Brown forwarded a letter to Senator Kennedy stating DOD objections to the bill as presently drafted. Copies of this letter were sent to Justice, the Vice President, State, and the CIA. Later that morning, a NSC/SCC working group meeting was held, at which time, a number of the DOD objections, as stated in their April 29 memorandum, were resolved.

~~CONFIDENTIAL~~

~~CONFIDENTIAL~~

104

As a result of this flurry of activity Brzezinski drafted, for the President, another clarification of who would be the lead in this legislative initiative and who would be the key point of contact with the Congress. This Presidential memorandum, dated May 4, was addressed to the Vice President, the Secretaries of State and Defense, the Attorney General, and the Director of the Central Intelligence Agency.

Signed personally by the President, the memorandum stated:

"I am concerned that as we enter into negotiations with the Congress on our proposed wiretap legislation, this Administration speaks with one voice. Accordingly, I am designating the Attorney General as the official responsible for conducting negotiations with the Congress on this legislation. All communications to the Congress on this subject should go through him.

"If there are differences of view on issues that may arise in the course of these deliberations with the Congress, they should be addressed in the Special Coordination Committee of the National Security Council and, if they cannot be resolved, they should be submitted to me for my decision."

This memorandum was presented May 5 to representatives of individuals listed on the memorandum at the NSC/SCC working group session devoted to revising the draft bill. Substantial agreement was reached between Justice and DOD on the key issues that had played back and forth for the previous several weeks. In almost daily meetings and/or telephone conversations from May 5 through May 13, final drafts, comments and revisions were made on the bill by Justice, DOD, OMB, and others. As early as May 6, all parties had substantial agreement on the bill with the exception of surveillance of foreign visitors. On May 9, agreement on the bill came to Justice from CIA and State. On May 10, the General Counsel of DOD gave clearance and on May 12, the FBI concern was ironed out with Justice and the Kennedy staff. At 11:30 a.m. on Friday, May 13, Justice reported to the parties involved, final agreement on the bill between Justice and Kennedy staff and the bill was forwarded to OMB for legislative referral and clearance.

~~CONFIDENTIAL~~

#### 4. ANALYSIS

This foreign intelligence electronic surveillance legislation case study touches significantly on many decisionmaking patterns. Following is a brief analysis of the case study in light of specific decisionmaking patterns.

##### a. Unit Coordination

In this instance, there was a need for immediate coordination of the disparate elements within the Administration. This was particularly true of coordination outside EOP. However, there seemed to be little awareness of an already existing coordinative mechanism - OMB. Through its Legislative Reference Division--and specifically through Circular A-19--OMB clearly spells out the procedures for arbitrating a piece of Administration legislation to the point of consensus. OMB Circular A-19 also indicates the appropriate manner for dealing with Congress prior to and after submission of legislation. OMB, while a part of the working group all along, was not utilized as a consensus coordinator until late in the game. The lead role given the Department of Justice, however, in the PRM-11 document, tended to short-circuit OMB's normal coordination role. A further explanation of this lack of OMB coordination may have been unawareness on the part of the principals involved of OMB's traditional role in the coordination of legislative initiatives. Suffice it to say that coordination, though intense, could have been more productive. EOP units that one would think should be involved in deliberations on this issue (e.g., Domestic Council, Lipshutz, OTP) had little or no input. Thus, there seemed to be a lack of coordination in determining initial entrants in the issue which, in turn, precipitated a need for greater coordination at a later point in time.

Another coordination factor which had an exceedingly influential role in the decisionmaking process was the involvement of the Senate Judiciary Committee members and their aides in the day-to-day development of the legislation. The decision to coordinate the terms of the bill with them, line-by-line and word-by-word, considerably slowed the development of an Executive Branch position. It also affected the extent and frequency with which DOD was required to submit its views to Justice and the White House.

~~CONFIDENTIAL~~

106

b. Delegation of Authority

In this instance, delegation was both the problem and the solution.

This case study may have been somewhat unique in that it involved principals on a consistent day-to-day basis at the very highest levels of government. Moreover, at least one memorandum was addressed to the President for resolution of matters such as word usage. The ultimate delegation of authority finally had to be made by the President himself (in the May 4 memorandum) in his designation of the Attorney General and the Justice Department as the lead individual and agency for this piece of legislation. This memorandum is interesting both from the point of view of its having to be written at all and from the point of view of its content. It resulted in cooperation and coordination among the principals which produced a much faster and comprehensive resolution of the issue.

Day-to-day review of activities in this case study seemed to have been done extensively from at least three different quarters - OMB, Justice, and DOD. To the extent that there was filtering process, it seemed to have been performed by Brzezinski and the NSC. An example of possible filtering was the decision made within the NSC not to send the May 2 DOD memorandum to the President but to draft a response in NSC for the President to send out (i.e., the May 4 Presidential memorandum).

c. Expertise Coverage

The issues that arise from this case study are actually issues of disagreement by experts. The Justice Department (and the intent of the legislation itself) is concerned with the constitutionality of electronic surveillance and appropriate protection of U.S. citizens and foreign individuals residing within the United States. On the other hand, the very real need for accurate and adequate foreign intelligence within the U.S. is a primary concern of the Department of Defense and the intelligence community, and their expertise is necessarily focused upon obtaining this information. The problem then was not really

~~CONFIDENTIAL~~

~~CONFIDENTIAL~~

107

one of lack of expertise coverage, but of sides being drawn along expertise lines. In other words, there was expertise coverage, but not a true integration of this expertise until late in the process, after Presidential intervention.

d. Focus of Administration Initiatives

Focus of Administration initiative was clearly a problem in this case study. The Administration initiative was initially delegated in PRM-11 to the Attorney General. Why then, was it necessary to reiterate this delegation of initiative more than two months later in the Brzezinski memorandum of April 25, and the Presidential memorandum of May 4? One possible answer is that PRM-11 itself created the confusion in focus in that, unlike the usual PRM process, it covered the gamut of electronic surveillance, assigning a number of working groups in several areas--the foreign intelligence surveillance bill being on one such initiative. Outside of the Attorney General, the Director of Central Intelligence also had a mandate for heading a working group under PRM-11. The President himself may have recognized this potential confusion, for he appended to the typed PRM the following handwritten note:

"Interrelationships among the various intelligence (units) will be assessed and recommendations made to me by the SCC as a whole." (The SCC, remember, is chaired by even a third principal, Brzezinski.)

e. Organizational Interest

This case study is a prime example of positions being taken out of organizational interest and fulfillment of organizational missions. DOD and the intelligence community were attempting to retain what they considered a critical level of capability in obtaining foreign intelligence, while Justice was interested in submitting a piece of legislation that would once and for all clear up the dispute over warrantless electronic surveillance in foreign intelligence cases.

Perhaps, the PRM-11 process should not have been structured so as to circumvent OMB as the traditional objective intercessor in the Administration's legislative process. In

~~CONFIDENTIAL~~

~~CONFIDENTIAL~~

108

fact, it was the OMB Legislative Reference Division which first indicated to the Carter Administration that an electronic surveillance bill was pending in Congress and that there was a need to examine the possible introduction of new legislation in this area.

However, the main point to be made here in this case is the role of the Attorney General and the Secretary of Defense in the development of legislation, and the involvement of the President in the decisionmaking process. The Attorney General, as the chief legal officer of the Government, is required to satisfy himself as to the constitutionality of any legislative measures that might be introduced. The Secretary of Defense, as the head of the military intelligence agencies, is properly concerned over retaining a foreign intelligence collection capability. In the early stages of the legislative process, the interplay of these interests worked relatively well; however, once the Attorney General was required to take on an additional role as chief negotiator with the Congress, a different set of interests came into play.

The Attorney General felt that certain accommodations should be made to the Congress, while the Secretary of Defense felt that such concessions were contrary to the interest of national security and would adversely affect foreign intelligence collection capability. It was at this critical point that the Attorney General and the Secretary of Defense escalated the issues to the point of direct Presidential involvement.

~~CONFIDENTIAL~~

~~CONFIDENTIAL~~

DECISION ANALYSIS REPORT

CASE STUDY: BREEDER REACTOR PROGRAM

~~CONFIDENTIAL~~

110

F. BREEDER REACTOR PROGRAM

1. ABSTRACT

The decision on the breeder reactor program occurred early in the Administration and a number of procedural problems that it raised have already been dealt with. At a more fundamental level, however, the evidence of what happened raises serious and enduring questions about the staging of decision processes; the relationship between foreign and domestic policy review on issues where the two come together; the interpretability and implementation of the President's decisions; and the behavior of policy staff in crisis situations.

The sequence of events was driven by two pressures. One was from the NSC side to produce a rapid response to European and Japanese challenges on the proliferation question. The other was the pressure to create a broad domestic energy policy with a minimum of early disclosure by April 20. The first pressure reduced the time to act; the second pressure reduced the number of actors in the policy process. The combination of the two sharply limited the extent of policy analysis that was brought to bear in the assessment of the LFMBR.

What the President gained in security on the sensitive issues, he may well have lost in the widespread misinterpretation that followed each decision that was made. This in turn adversely affected the credibility of the decision process and encouraged both EOP staff and outside interests to seek new decisions or reruns of old ones. This wasted everybody's time.

In this sense, the effort to limit the number of active participants not only failed to work as planned, it had two further unanticipated effects. One was to permit the President to be unaware of the full range of options available. Another was to encourage the President to make decisions one at a time without his attention being drawn to the potential for inconsistency implicit in such a step-wise progression.

What went wrong in reorganization terms might be roughly termed a coordination problem, whose solution lies in better decisionmaking routines, greater consultation,

*J. Staler*

CONFIDENTIAL-GDS (Declassified on December 31, 1983)

~~CONFIDENTIAL~~

111

and better management of scheduling to avoid bottlenecks and paper flow problems. What is missing from the organizational performance that cannot be so simply and economically improved is the absence of reliable follow-up of the President's decisions. No one has the responsibility of ensuring that once made, his decisions are interpreted correctly by the agencies and implemented as he means them to be.

## 2. BACKGROUND

In this section day-by-day events are chronicled in such a way as to identify the important issues and key players as these emerged.

- o See Attachment A for summary data on Presidential and Cabinet attention to the issue, and the key players involved.
- o Key players or active participants in the decision process are identified as those individuals who interact on the issues outside their EOP unit or agency, and do so more than once. Attendance at an interagency meeting is treated as multiple interaction for this purpose. For full list, see

## 3. CHRONOLOGY

### January

- 21 PRM-15 is issued for the development of nuclear proliferation policy options. Participants in the working groups include NSC (Tuchman), Energy Policy and Planning Group (EPPG)(Ahearne), OMB (Taft, Kearney, Weiher, Donahue), State (Nye), Council on Environmental Quality (Speth, Brubaker), Arms Control and Disarmament Agency (ACDA) (Spier), Nuclear Regulatory Commission, DOD, CIA, Energy Resources and Development Agency (ERDA).
- 26 NSC memorandum to Joint Chiefs of Staff on PRM-15. JCS added to list of units receiving documents.

~~CONFIDENTIAL~~

~~CONFIDENTIAL~~

February

112

- 4 Schlesinger sends budget recommendations covering the LMFBR to OMB Director Lance. A copy goes to Schirmer of the Domestic Council (DC) who is concerned about the level of spending in relation to Presidential campaign commitments to cut the program.
- 5 OMB briefing on 1978 Budget amendments. There are a number of briefing discussions involving the nuclear energy budget. Participants include Kearney (OMB), Freeman (EPPG), Fri (ERDA), Tuchman (NSC), Brubaker (CEQ), Harrison (Vice President's Office), Schirmer (DC), Spier (ACDA). ACDA recommends a shift in funding priorities to reflect the relatively greater security to be gained from alternative nuclear fuel cycle technologies such as thorium.
- 7 Article appears in New York Times stating that the "President urged cuts in nuclear breeder device, but his aides now propose an increase." Criticism of what is described as a contrast to the President's campaign commitment is attributed to Russell Train, former Chairman of CEQ.
- o Christopher (State) writes Lance expressing reservations about the implications of the breeder reactor budget.
  - o Tuchman calls a meeting of several key participants in the budget revision process for the breeder reactor and the PRM-15 working group on proliferation; included are Schirmer (DC), Loweth, Cutter, Nix, and Kearney (OMB), Freeman (EPPG), Nye (State) and Fri (ERDA). The meeting attempts to clarify the level of budgetary support for the breeder reactor program. Three options are tabled: (a) to cut budget below the 1977 level; (b) to remain at the 1977 level; and (c) to increase level of spending (the ERDA option).
  - o After the meeting, Kearney (OMB staff) prepares a detailed budget review book on the program. He also prepares an issue paper for the President, incorporating suggestions from Schirmer that strengthened the cut option. This paper appears not to have reached the President. Instead, Cutter, Schlesinger, and Brzezinski discuss it among themselves.

~~CONFIDENTIAL~~

~~CONFIDENTIAL~~

February

113

- 8       Tuchman writes memo for the President through Brzezinski. She assumes that the President will read it but in fact it is delayed in channels. What she recommends is a budgetary cut for the LFMBR.
- o A group of Princeton scientists write the President urging, inter alia, that he consider alternative nuclear fuel cycles that do not have the proliferation problems of the plutonium cycle. The letter refers specifically to "the possibility of a fuel cycle based on thorium, using denatured uranium-233 as fuel." There is no evidence in the log that the President received this letter, read it or referred it to his staff.
- 17       Tuchman sends a brief summary paper to the President reiterating the recommended budget cut but omitting the supporting discussion. The President indicates in the margins that the issue is not related to national security. However, the President then receives the longer memo of the previous day and reconsiders his earlier comment. He accepts the national security implications and decides in favor of the recommended cut. This is the option that Cutter, Schlesinger and Brzezinski have already agreed on - a reduction of \$30 million in budgetary authority for the program. All are in agreement that the budget decision is a temporary one pending completion of the PRM-15 (proliferation) and LMFBR policy reviews. What is not communicated to the junior staff level is when the final decision will be reached or what its implications are likely to be.
- 22       The breeder reactor review panel is established on the instructions of Schlesinger.
- 25       Tuchman requests that Brzezinski extend the PRM-15 deadline to March 9; he assents.

March

- 4       The President writes in reply to a query from Congressman Harkin (Dem., Iowa, House Subcommittee on Energy Research, Development and Demonstration) stating that the breeder reactor is a national security risk.
- 9       PRM-15 is completed and circulated for comments to relevant agency and unit heads. Comments are received over the next ten days in the NSC files from Warren (CEQ), Christopher  
and Wernke (ACDA).

~~CONFIDENTIAL~~

114

March

- 16 Policy Review Committee meeting is held to discuss PRM-15. Speth (CEQ) is not permitted to participate in the review discussion.
- 21 President meets with Prime Minister Fukuda; he is also introduced to the Ford Foundation Panel on nuclear power by Science Adviser, Frank Press. The President recommends the Panel report to the Prime Minister (the implication being that the President agrees with the Panel's argument against plutonium-cycle energy production). He also tells the Prime Minister that there will be time for the Japanese Government to consider its own policies in this area as no major policy decision will be announced by the U.S. until the entire energy program is finalized (due April 20).
- 22 Aaron (NSC) tells Tuchman that a statement on proliferation policy should be delivered by the President at his press conference on the 24th. Tuchman is drafting the text of Presidential Directive 8 (PD-8) implementing the Committee review of PRM-15. The issue of timing an announcement on proliferation is raised by the NSC with State, and a delay is sought to give U.S. embassies time to inform and consult with foreign governments, particularly the Japanese. PD-8 is sent to the President for approval with the recommendation of a delay in announcements. The President signs approval, and after a discussion with Brzezinski, accepts the case for delay.
- o Barbara Blum, Deputy Director of EPA, writes NSC complaining that her agency has been excluded from the PRM-15 process; CEQ does the same.
- 26 State Department and NSC exchange drafts of cables dealing with PD-8. These are approved by the President and sent out to embassies on the next day.

~~CONFIDENTIAL~~

~~CONFIDENTIAL~~

115

April

- 1 Following up PD-8, and at the President's request, Ahearne drafts a statement of policy on the domestic breeder program for Schlesinger and Brzezinski to comment on. Ahearne is assisted by Sievering (ERDA), and Elliott from the Science Adviser's office. The document is not circulated at this stage to other EOP staff who had previously been involved in review of the breeder reactor program.
- 2 Christopher (State), testifying before the Senate Subcommittee on Nuclear Proliferation, tells Senator Glenn, the subcommittee chairman, that within a week the President would issue "a major statement on nuclear energy" that "will go a long way towards clearing the air with respect to domestic policy." Senator Glenn repeatedly requests details of the Administration's likely plan.
- 4 Department of State sees a copy of the Ahearne draft of the President's statement.
- 5 The West German government notifies the U.S. that it is approving export licenses for blueprints of uranium and plutonium production facilities for export to Brazil. The U.S. had sought to persuade the Germans against this step towards what it characterized as nuclear proliferation.
- 6 Kearney (OMB) sees a copy of the Ahearne draft. Although uninvited, comments and small changes in phraseology are submitted at the last minute by OMB to Schlesinger. These relate to the Administration's position on the private fuel-enrichment plant being built at Barnwell, S.C. Brzezinski probably sees the draft statement before it is transmitted to the President.
- 7 The President meets at 11:05 a.m. with Powell, Tuchman and Schechter (NSC) to discuss the press briefing to follow on nuclear energy. Eizenstat joined the meeting for ten minutes.

~~CONFIDENTIAL~~

April

- 7  
con'td
- The President then releases a statement on the domestic implications of his nuclear proliferation policy. The Clinch River breeder reactor is slated to be cut back to an "experimental basis." This terminology is confusing and in the question-and-answer session that followed the statement the President said that it did not mean termination of the Clinch River plan. In the private staff meeting, the President also refers to the problem of what to do with the Clinch River breeder reactor. He has heard from both Senators Glenn and Sasser, each anxious about their own state's role in the LMFBR program. The President suggests that perhaps the enrichment facility intended for addition to the Portsmouth, Ohio, gaseous diffusion plant might be constructed at Clinch River. Tuchman tells the President that this is technically impossible.
- o Subsequently on that day Senator Baker (Tenn.) tells The Times that he understood that work at the Clinch River Plant would be stopped. Senator Sasser, first-term Democrat and close political associate of the President, says that the understanding he had received was that "no more than a reassessment of the Clinch River project" was contemplated.
- 8
- Concerned with what he saw as substantial ambiguity in the President's press conference, Speth (CEQ) instructs Brubaker to begin drafting a CEQ memo for the President. This seeks to sharpen the policy on the LMFBR program, and by adding specificity in the language, to reduce the misinterpretation that CEQ believes the Presidential statement could give rise to.
- o Schirmer (DC), who had not been consulted before release of the statement, asks for clarification of its meaning from Freeman. She is told that the statement is essentially a holding action, designed to placate the needs of NSC, Department of State and foreign

~~CONFIDENTIAL~~

117

April  
8  
cont'd

- governments concerned about U.S. intentions for the domestic and international uses of plutonium.
- o Fri, Acting Administrator of ERDA, testifies to the Glenn Subcommittee that the President's statement of the previous day would "increase the problem and also increase the need for more technical data" on storing spent fuel, which would otherwise be used in the breeder reactor program. This statement is interpreted by other players as potentially undercutting the Presidential commitment.
  - o The Washington Post reports from Japan that government officials there are uncertain about the implications of the statement for their own breeder program and for the imported reprocessed uranium they require from the U.S. to fuel their plant at Tokai Mura.
- 9 The report of the breeder reactor review panel is delivered to Fri who sends a summary to Schlesinger, together with the draft of a memorandum for the President.
- 10 Schlesinger delivers a memo to the President recommending a range of actions to be taken on the future of the LMFBR. This does not argue options, pro or con, nor the consequences of alternative decisions relating to the LMFBR. OMB and the DC do not see this document until after the President signs off. What the President appears to have accepted was a proposal for deferment of construction at Clinch River with extended research and testing, in conjunction with advisory recommendations from the Nuclear Regulatory Commission (the licensing authority) as to the "licensing status" of the project. In short, this represented an advancement of the project through an informal licensing procedure as a preliminary to the formal licensing agreement necessary for construction. It was unclear to many of the players whether this meant that the program was to be continued or stopped.

~~CONFIDENTIAL~~

~~CONFIDENTIAL~~

118

April

- 14 Warren and Speth (CEQ) send a memo to the President. It is staffed out to the following people before going to the President: the Vice President, Brzezinski, Schlesinger, Eizenstat, and Watson. Copies are also relayed to Tuchman and Schirmer. The memo argues for clarification of the President's position on LMFBR. Specifically, it recommends not proceeding with any form of licensing or construction. The President assents to this. Brubaker then checks with Ahearne to ensure that in preparation of press releases, ERDA's language reflects the position embodied in the CEQ memo rather than the one in the Schlesinger memo of the 10th that was much closer to the agency's wishes.
- 16 A general meeting is held with the President in the Cabinet Room to resolve issues in the energy program. Attending (inter alia) are Schlesinger, Alm (EPPG), Schirmer, Cutter, Lance, Tuchman, Schultze and Blumenthal. Approximately five minutes are given to the LMFBR program. The issue as it is presented for decision is whether the Clinch River project should be advanced through to a licensing process or not. The President indicates not.
- o At this time also, Press, the Science Adviser, recommends to the President that he consider adapting the Clinch River reactor design for development of the thorium cycle. This he argues would keep Clinch River operating but avoid the serious proliferation problems inherent in the plutonium cycle intended by ERDA. The President responds by indicating that this option had not been presented to him before.
- 19 A long evening meeting is held to finalize the draft energy statement due to be released in the morning. Schirmer confirms that the draft indicates the determination not to proceed to any form of licensing.
- 20 The President announces his energy policy. The words chosen to describe the LMFBR include the "deferment" of commercial reprocessing and recycling of plutonium; the "cancellation of construction of the Clinch River Reactor Demonstration Project and all component construction, licensing and commercialization

~~CONFIDENTIAL~~

April

119

25 OMB refers an advance copy of Fri's testimony before the House Subcommittee on Energy and Environment to Tuchman.

- o Tuchman rings Fri's office and states that the testimony will not be cleared unless the wording is changed to conform more precisely to the Presidential policy. Speth expresses the same objections.

This does not mark the end of the decision process. Several of the players express concern through the next five weeks that ERDA testimony before Congress undercuts the President's April 20 decision. This in turn fuels congressional action to overturn the decision or have the President clarify it in a way that would favor special State and breeder reactor interests. This additional stage of decisionmaking is described below (p. 15).

#### 4. ANALYSIS

##### A. The Decision Process

###### (1) The Complexity of the Issues

In an economy whose demand for electricity will outstrip the supply of fossil fuels needed to produce it by the end of this century, alternative sources of energy must be found and quickly put in development. It stands to reason that an energy-generating technology like the LMFBR would provide a substantial energy benefit, even at fairly high levels of capital investment and operating cost. That is supposing the technology is safe from accident or sabotage; that its waste can be put out of harm's way for half a million years; that the costs of alternative energy sources make them less economical; that the economy will need as much electricity as is now thought; and that a world energized by thousands of plutonium reactors is as comfortable as the world of oil and coal-fired stations we are still enjoying. At bottom, these suppositions contribute to the decision problem for the LMFBR.

But these are not the only issues. In fact, the LMFBR either directly or indirectly involves more elements of decision, and conceivably more jurisdictions and decision makers, than any other current problem that has faced the Administration.

The program is complex in several ways:

~~CONFIDENTIAL~~

~~CONFIDENTIAL~~

120

a. Technical Disputes. Every-one of the above suppositions is disputed by groups of professional scientists, engineers, and environmental planners. On the economic cost-benefit side, there are several detailed analyses from ERDA, two from GAO, two from the Joint Economic Committee of Congress, one from the Congressional Budget Office and numerous private and institutional studies. These don't agree.

b. Regionalism. The component technology on which the LMFBR depends is in varying stages of evolution, depending on the components. These are being researched, demonstrated and tested in twenty-two facilities scattered over sixteen States. The cost of this part of the program is over \$1 billion. Any decision affecting the breeder reactor will thus have ramifications affecting employment and investment around the country.

c. Problems of Research and Demonstration. The program was originally designed in a series of steps leading from basic components and process research, through the construction of a sequence of demonstration plants (each larger than the one before), to the full implementation of a commercial breeder system, beginning with one in 1987 and numbering 1,178 by the year 2011. The distinction between what is research, what demonstration and what phased commercial development is very difficult to draw. The average annual cost at current levels is \$600 million (with a total cost to 1987 of at least \$10 billion). Each new outlay has the effect of tying the project to a direction that limits the resources available to alternative paths, to alternative energy technologies, and to alternative goals. At present the LMFBR program is the single largest commitment in the energy R&D budget (40 percent 1971; 26 percent 1976) which in turn absorbs nearly 10 percent of all Federal R&D. Decisions affecting LMFBR thus structure the entire range of R&D options available to the Federal Government.

d. Private Investment Impact. Both Federal Government and private sector funds and management are involved, the private sector significantly less than was originally planned for. Decisions on LMFBR affect long-term investment plans throughout the nuclear industry, which actively resists the non-plutonium options.

~~CONFIDENTIAL~~

~~CONFIDENTIAL~~

121

e. Environmental Issues. Environmental impacts are very difficult to assess. Early impact statements for the first LMFBR (Clinch River, Tennessee) have been disputed, and EPA's judgment is that the commercialization of LMFBR cannot be assessed reliably at this stage. ERDA program managers have asserted in response that at this stage the project status is strictly R&D and that no decision regarding commercial implementation will be made for another decade. However, the level of spending is so great as to preclude the development of alternative energy sources, thus locking the Administration into a 1987 decision whatever the environmental assessment.

f. Foreign Policy Priorities. No decision on LMFBR can be reached without wide-ranging foreign effects. The Soviet Union, France, England, West Germany, Japan and several European consortia are actively developing domestic breeder reactor systems, and in some cases (France and West Germany) an export industry in the same technology. There are many interested importers (Brazil, India, Israel, etc.). The possibility of proliferation of plutonium plants, of nuclear weapons manufacture, of theft of nuclear explosives for political purposes, and of shifts in the pattern of limited nuclear monopoly and the strategy of deterrence on which it depends, are some of the issues involved.

(2) The Dynamics of the Process

a. Timing and Staging. There are three or perhaps four stages in the process depending on how the decision of April 20 is interpreted. What drives the staging of the process is this: each decision reached is vague enough to be interpreted quite differently by major participants. This then requires a further policy review to resolve the issue on each occasion. Staff work does not significantly reduce the issues or options for Presidential decision at each stage, so that the President is confronted by roughly the same set of problems on each occasion.

These issues came up as a result of quite separate though parallel policy review processes (i.e., the foreign policy-PRM process, the Schlesinger EPPG process, and a broad domestic policy review process). Neither the schedules nor the outputs of these processes were coordinated with one another; consequently it was inevitable that the President would be required to respond to each in turn, and that each of his responses would be misunderstood by the participants on the other tracks.

~~CONFIDENTIAL~~

~~CONFIDENTIAL~~

122

The gloss put on these misunderstandings was that until the April 20 decision there had been a series of temporary decisions - holding actions pending a more detailed and coordinated review of the issues.

b. Holding Action No. 1. The first stage reflects the negotiations on the 1978 budget levels for the LMFBR program. The timing was dictated by the February deadline, but neither the proliferation policy nor the energy policy could have been ready by then. On the other hand, the President was clearly on record as being opposed to the breeder reactor in one form or another.

Campaign promises left a fairly wide margin for defining policy and program recommendations, which might have become the focus of the February discussions. The fact that they did not appear to have been the result of Schlesinger's ambivalence about detailing the future of the program, and his unwillingness at that stage to engage the other participants in analysis of the options and contingent funding levels. His position in turn depended on the President's desire to limit internal debate on elements of the energy plan.

The NSC position and the DC position were in accord, insofar as both sought a budget option that would demonstrably reinforce the campaign commitment, and indicate to foreign governments the Administration's determination not to proceed with the plutonium cycle in commercial energy production.

Again, the pressure of the clock appears to have driven the players away from detailed options analysis. The impending West German and Japanese decisions, and related problems scheduled for international meetings in London, Persepolis and Salzburg, encouraged Brzezinski to press the President for statements that could then be taken into proliferation negotiations abroad. Without detailed planning of the LMFBR options however, whatever statements the President might have been induced to issue, ran the risk of leaving the options for the domestic program too open and appearing vague, if not intentionally deceptive, to the foreign powers.

Alternatively, if the President sought to be the clear opponent of plutonium proliferation in the foreign arena, he ran an uncharted and untested

~~CONFIDENTIAL~~

~~CONFIDENTIAL~~

123

course in Congress on the domestic issues. These problems were compounded by the unilateral tactics pursued in this early stage by both Brzezinski and Schlesinger, whose regular access to the President enabled each to act on his own priorities without informing or consulting the other.

c. Holding Action No. 2. The second stage ran from late February to April 7. In this period, the President made the decision to release a statement "to stop breeder reactors" (Washington Post, April 8). This decision did not in fact stop the LMFB program.

The decision was reached by two or three paths, depending on how you count. One was a review team picked largely by Freeman (EPPG) and Thorne (ERDA). Composed of non-government experts and public interest representatives, it was heavily weighted on the pro-breeder side, so much so that at least one of the anti-breeder side threatened to resign. It was, as one observer called it, "a charade which all the real policy makers waited to conclude."

The other perspective was that the panel was the last chance the breeder proponents would have to make their case before the axe fell. The situation was quite unclear -- the panel was stacked to be sure, but which side of the policy fight would get the coup de grace no one knew for sure.

The timing of the second stage was in fact determined by the NSC, the completion of the PRM-15 deliberations and the President's assent to PD-8. The visit of Fukuda, the German-Brazilian deal, last minute negotiations with Japanese officials and State's preparations for the London conference of nuclear suppliers (the last two on the weekend of April 2-3) - these were the immediate pressures which drove longer-term policy planning out of channels for Presidential review. Time and access pressures, further stimulated by demands from Congress for a policy statement from the Administration, so clogged the channels that, as noted on February 17, the President signed off on one recommendation without reading the policy analysis supporting it; this had been logged in but not read the day before.

However accidental this incident may have been, it is symptomatic of a common effect of uncontrolled timing on policy review -- in a crisis situation the need to act absorbs whatever resources are available to

~~CONFIDENTIAL~~

~~CONFIDENTIAL~~

124

consider the options. Thus in crisis at the executive level, policy review as such stops. (This is the stampede phenomenon.)

The PRM process is designed to avoid this. It should predict in advance what executive decision needs will be, and schedule staffing to meet those needs with time to spare in case of interagency conflicts or unpredictable external events that demand rapid response. Also, it should integrate domestic policy concerns into the final analysis of options. Neither objective was achieved by PRM-15 in this case.

The April 7 statement produced a rush of misinterpretation and confusion. Congressional doubts created demands for clear delineation of Administration intentions but the terminology in which the options were publicly cast did not resolve underlying ambiguities about the research status of the Clinch River breeder reactor, the level of funding of the component program supporting the reactor, the regional implications of both these things (especially for Ohio and Tennessee) and the alternative development paths into the future for nuclear energy research.

d. The Final Stage of Decision. Stage 3 ran from April 7 to April 20 and reflects the process by which the President accepted a range of options on what to do about the LMFBR, the plutonium cycle in general, and the Tennessee facility in particular. Deliberation on the options continued right up to the morning of the Presidential speech on energy. But even at this point the participants remained unclear on the concrete implementation of the options. Additionally a number of important policy considerations omitted in the earlier process now reemerged.

These involved players who had not participated at all in the earlier stages -- specifically Hamilton Jordan and Mark Siegel who enter at this point to negotiate with state officials and Congressmen from Tennessee and Ohio, the two states most immediately affected by the decision.

These negotiations lasted for more than a month (May 25) before the President issued a clarification of the budgetary implications of the April 20

~~CONFIDENTIAL~~

~~CONFIDENTIAL~~

125

decision for Portsmouth, Ohio, and Clinch River and Oak Ridge, Tennessee, the principal locations of ERDA's reactor research effort. During this period too, there was intense Congressional activity, with one House committee voting to restore the breeder reactor funds and a second committee of the House voting to sustain the President's cut. Opposition was vocal in the Senate also (reflecting in part Senator Jackson's home State interest in another component of the research program) but this had not resulted in a vote by the end of May. Six weeks after the final decision had been made on the LMFBR program, the President was still compelled to reiterate and refine the terms of that decision for those who felt he might still be shifted.

e. Stampede Tactics. There was an important relationship between timing and staging. Without clearly marked stages of decision, deadlines and finality to the decision itself, the timing of the process was both infinite as the stages were reiterated, and subject to sudden crisis. Insofar as all decisions appeared temporary and the time limits extendable, those players dissatisfied with the outcomes at one stage could aim to recover their initiative by launching a new round. Fostering a crisis atmosphere was, in this context, one tactic for out-maneuvering other players in the ongoing policy debate. Of course, the advantages so gained can only be temporary before the process begins all over again.

f. Analysis of the Domestic Options. The President's statements during the campaign created an unusual situation in this case -- one option, that of moving to commercial development of the breeder reactor, had been ruled out. Still, the campaign statements were compatible with the continuation of Clinch River as a research and demonstration project, and indeed that was what Clinch River had always been. The Ford Administration and ERDA, committed as they were to full-scale application of the plutonium fuel cycle, did not regard Clinch River as anything more than a demonstration project. It was an expensive one to be sure, with investments that tended to carry the commitment to commercial implementation at some time in the 1980's. Thus, even before taking office, the termination option became the symbol of Mr. Carter's campaign promise.

Between immediate termination and continued acceleration of program outlays, as ERDA had proposed in the Ford Budget for 1978, there was a spread of \$736 million. What were the options for spending?

~~CONFIDENTIAL~~

Mr. Schlesinger's group had the lead in developing these, but the recommendations of early February raised the concern of many of the participants that EPPG was doing little more than fronting for ERDA.

On the other hand, given the size of the group's task in formulating a comprehensive energy policy and the shortness of time in which to do it, Schlesinger had little alternative but to rely on ERDA for detailed technical work on the nuclear energy proposals. Whether EPPG was acting as ERDA's advocate on behalf of the program or not, there was a widespread perception among the other players that the former was the case.

This perception provoked the leak to the New York Times and the February 7 meeting which followed publication. From this point on, the lead seems to have been taken by the NSC, which was committed less to working out the details of the domestic program than to making a credible cut in the LMFBR budget to signal the new policy abroad. OMB was in a position to assess detailed program options, and did, but this was not the direction that the decision process took. Instead, three very broad options were discussed (see page 112) with a cut of \$199 million in budget authority recommended to the President.

As a signal this was ambiguous. ERDA knew that reevaluation of the program would continue but the February cut was certainly not something that threatened the future of their program. When they had costed the 1978 Carter Budget out, they were able to plan outlays at \$651 million, less than the Ford level for that year but still over 10 percent greater than the 1977 total. After cutting out construction of an additional large demonstration plant, ERDA was able to increase outlays on all line items of the program (over 1977 levels), including a 22 percent rise in spending at Clinch River. As ERDA understood the situation in February, their R&D project was still very much in business.

One view is that the NSC did not care about these details; their priority was the PRM process and the negotiation of an effective limit to plutonium use abroad. Schlesinger, meantime, sought to delegate his own initiative to ERDA and to the independent review panel. The other domestic policy players were more or less excluded from both processes.

~~CONFIDENTIAL~~

127

In the sequence of events culminating in the April 7 statement, there was no analysis of domestic programs at all. OMB had the capacity to contribute but was excluded, the Domestic Council staff likewise. The pressure of the foreign policy contingencies -- the crisis stemming from uncontrollable actions by the German and Japanese governments, and the volume of paper flowing to the President associated with PRM-15 and PD-8 -- effectively drove domestic policy out of consideration.

After April 7 attention could be focused on the domestic future of the LMFBR. The strategy Schlesinger pursued was to avoid detailed review of alternatives in his own memorandum to the President (April 10), and to exclude other domestic policy reviewers from the process. When the President consented to his recommendation, no one but the President and Schlesinger knew what the decision actually implied. The details appear to have remained ERDA's responsibility to outline and implement.

The CEQ memo was the first detailed assessment of what cutting the program might actually mean. Circulated both before and after the President saw it, it brought several of the program options into the open. These included a testing program and proceeding to a form of licensing, preliminary to undertaking construction (ERDA's preference), a modified design and review program done in conjunction with the NRC (Schlesinger's preference), and abandoning all licensing efforts and cancelling all construction at Clinch River.

CEQ, OMB and DC all agreed that the LMFBR program had to be reduced to a level of design completion. They argued against further testing, licensing or construction. In their view, the project should terminate within two years as the design programs came to an end. Schlesinger's April 10 memo provided no details of out-year expenditures and no consideration of the public impact of continuation at whatever level the quasi-licensing process required. OMB staff work added the option costs and stated that the likely public response to the EPPG plan would be hostile.

The meeting with the President on April 16 spent little time on the LMFBR. For one thing, the President may not have been aware of the extent to which there were different views in the EOP and ERDA on his policy.

~~CONFIDENTIAL~~

~~CONFIDENTIAL~~

128

He had clearly signalled his intention to abandon licensing in his response to the Warren memo. He may have thought this had been equally clear in the acceptance of the Schlesinger recommendation the week before. That it was not clear appears very much to have been the result of the inadequate staff work that supported the earlier submissions. The circulation of documents to achieve clarification and consensus on the implementation of the decision was also inadequate.

g. The Option That Never Was

The chronology shows that as early as February 8, when a number of Princeton scientists wrote the President, the option existed for the President to terminate the plutonium LMFBR program but continue Clinch River, modified to test and develop the thorium cycle.

Active canvassing of a range of alternative nuclear fission options had been encouraged by the Bureau of Proliferation at the Arms Control Agency (ACDA). The alternative fuel cycle approach had also been touched on in a report issued by the congressional Office of Technology Assessment. The ACDA view surfaced during the February budget review of ERDA programs. The Princeton group argued its case on the breeder review panel during March and in April issued a special report on the option through the Council on Foreign Relations.

There is no evidence, however, that the President was ever given a detailed briefing or memorandum on the thorium fuel cycle as an alternative application of the Clinch River program. There are two explanations for this. One is that ERDA, which had been considering the option internally, chose not to raise it openly so long as the chance remained that the President might opt for the plutonium program. If this is the case, then ERDA wittingly or unwittingly reduced the President's range of choice for the narrowest of partisan advantages. The effect was that by the time the Science Adviser raised the issue directly though briefly with Mr. Carter, there was little room for him to maneuver.

An alternative view is that the internal review of the thorium option which the ERDA staff had conducted had led to their judgment that it was not viable as a method of prolonging the life of Clinch River. ERDA representatives had argued the case on this with the Schlesinger staff, who concluded for themselves that the modifications that would be involved in the Clinch River reactor were more expensive than the program's survival was worth. This was a considered technical judgment, and no doubt a reasonable one. Still, it was never surfaced for the President himself to weigh.

~~CONFIDENTIAL~~

~~CONFIDENTIAL~~

129

5. SUMMARY FINDINGS

A. Coordination

These were early days in the Administration, and some of the difficulties reflected in the analysis were acknowledged at the time they occurred. Brzezinski and Schlesinger agreed that coordination and improved definition of roles were necessary after the February decision; Brzezinski and Eizenstat agreed on improved consultation after the April 7 statement was issued.

Coordination and consultation should have been better by April 10, notwithstanding the fact that Schlesinger had a mandate from the President to develop energy policy without wide review by EOP staff. This was a reasonable precaution against premature release, but a premium was paid in that the President's decisions were not clear to either EOP or agency (ERDA) staff. To the extent that they remained so, the process of decisionmaking was unnecessarily prolonged. The President's credibility on the issue also suffered some damage as conflicting statements and interpretations filtered into the press. This was especially damaging in the eyes of the Germans and Japanese, not to mention the people of Ohio and Tennessee.

B. Priorities

The case suggests that to the extent that foreign policy problems are brought into the executive decisionmaking process with short lead times (typically involving large numbers of options and separate decisions which the President is required to address), they can capture a higher priority in the President's time and attention than can domestic policy issues. Here it seems not only that the NSC took the lead in the budget and April 7 stages, but that the PRM decision entirely blocked for a time review of the detailed domestic options and the factors which were relevant to their assessment.

~~CONFIDENTIAL~~

~~CONFIDENTIAL~~

If the President had more than 24 hours in a day, then he could compensate for this tendency. Alternatively, he could require that a sharing or queuing procedure be employed to distribute the inflow to the decision box between types of issues, just as he currently allocates meeting time on a fair-share basis.

If there is no "fair sharing" or allocation principle in use, then the dynamics of the decisionmaking process and the tactics which units develop to improve their access (stimulation of decision pressures or stampede tactics) will produce the effects that have been noted.

C. Crisis Response

There is some evidence to suggest that current decisionmaking routines are too inflexible and too uncoordinated to provide rapid policy response, covering all relevant issues, in crisis situations of either domestic or foreign origin.

D. Expertise Coverage

There was little expert input from the economics side, from environmental impact assessment or from the budget examiners' review. What was available was perceived as special pleading from ERDA on the pro breeder side. In the context of the broader nuclear proliferation issues on the foreign side, and the multi-faceted energy package on the domestic side, decisions on the LMFBR were made with relatively little time, space or resources spent for detailed examination. The regional effects of changes in the component programs did not surface until very late and Congressional reaction was scarcely explored at all in advance. Thus, those responsible for dealing with the Congressional and regional response after April 20 (Jordan and Siegel) were unbriefed on the decision and its budgetary implications, and unprepared to defend what had been done. Worse, EOP participants differed in the detailed interpretation they could provide of what in fact had happened. This is linked to a final key finding:

E. Monitoring Compliance and Implementation.

It took ERDA nearly a month to issue orders to destroy booklets the agency had prepared on energy policy which gave a positive impression of the breeder reactor program. It was quite fortuitous that Fri's testimony for

~~CONFIDENTIAL~~

~~CONFIDENTIAL~~

April 25 was seen in time by EOP staff to conflict with the April 20 decision. This shouldn't be taken to imply bad faith on the agency's part. What is clear, however, is that in this case the Presidential decisions were not easy to interpret, and that no mechanism exists that can reliably be counted on to follow up such decisions, to see that the interpretations which are given of them are ones the President himself intended. The latitude for misinterpretation and the arbitrariness of compliance procedures in the Executive Branch are serious problems which this case has identified.

~~CONFIDENTIAL~~

~~CONFIDENTIAL~~

6. ATTACHMENT

132

Background Data

Events

1. Presidential attention: The President read four memoranda (approximately) and PRM-15; 20 minute meeting of April 7; 5 minutes at meeting of April 16.

2. Cabinet attention: Issue referred to in Minutes of March 7 and 28.

List of Active Participants in the Decision Process\*

The President

James Schlesinger (Energy Planning and Policy Group)  
John Ahearne (EPPG)  
David Freeman (EPPG)

Stuart Eizenstat, Assistant to the President for Domestic  
and Policy  
Kitty Schirmer, Associate Director, Domestic Council (DC)  
Zbigniew Brzezinski, Assistant to the President for National  
Security Affairs  
David Aaron, Deputy Assistant (NSC)  
Jessica Tuchman (NSC)

Charles Warren, Chairman Council of Environmental Quality (CEQ)  
Gus Speth, Member, CEQ  
Gerald Brubaker (CEQ)

Bo Cutter, Executive Associate Director, OMB  
Joe Kearney (OMB)  
Rod Weiher (OMB)  
Dan Taft (OMB)  
Arnold Donahue (OMB)  
Hugh Loweth (OMB)  
Jim Nix (OMB)

Frank Press, Director, Office of Science and Technology Policy  
David Elliott (formerly consultant to OSTP)

Cyrus Vance, Secretary of State  
Joe Nye, Under Secretary of State for Security Assistance  
Richard Holbrooke (State)  
Warren Christopher (State)

\*Defined as a player who interacts on the issue outside his/her agency or EOP unit more than once.

~~CONFIDENTIAL~~

~~CONFIDENTIAL~~

133

Robert Fri, Acting Administrator (ERDA)  
Robert Thorne (ERDA)  
Nelson Sievering (ERDA)

Barbara Blum, Deputy Administrator, Environmental Protection  
Administration

Paul Warnke, Director, Arms Control and Disarmament Agency (ACDA)  
Richard Spier (ACDA)

Senator John Glenn, Chairman Senate Subcommittee on East Asian  
and Pacific Affairs

Senator Sasser (Tenn.)  
Senator Baker (Tenn.)

Hamilton Jordan (WHO), Assistant to the President  
Mark Siegel (WHO)

Victor Gilinsky, Commissioner, Nuclear Regulatory Commission  
Edson Case (NRC)

The Vice President  
Gail Harrison (VPO)

---

Total 40

---

~~CONFIDENTIAL~~

CONFIDENTIAL

DECISION ANALYSIS REPORT

CASE STUDY: CONVENTIONAL ARMS TRANSFER

~~CONFIDENTIAL~~

135

G. CONVENTIONAL ARMS TRANSFER

(In order to avoid disclosure of classified or otherwise sensitive information, this report will be limited strictly to a discussion of the process and the players. Decision options and recommendations have been omitted.)

1. ABSTRACT

The case study reviews the development of policy on conventional arms transfers to foreign countries by the U.S. Government and U.S. commercial firms. Specifically, the paper describes activities in response to (1) Presidential Review Memorandum/NSC 12, Arms Transfer Policy Review (PRM 12), and (2) the reporting requirements of the International Security Assistance and Arms Export Control Act of 1976 (AECA 76).

The PRM activities focus on the Policy Review Committee (PRC) structure established by Presidential Directive/NSC 2, the National Security Council System. The AECA 76 activities focus on the preparation of (1) the President's response to Section 202, and (2) the Secretary of State's response to Section 218 of the AECA 76.

Presidential Review Memorandum No. 12 calls for a thorough review of U.S. policy on international transfer of conventional arms. The PRM effort is under the chairmanship of the Department of State. Section 202 of the AECA 76 requires the President to submit to the Congress by June 29, 1977, a report on (1) arms sales policies and practices of the United States Government; (2) the effects of such policies and practices on world peace, foreign governments, and the economic and social development of foreign countries; (3) U.S. efforts at arms sales limitations during the past five years; and (4) current efforts to initiate and encourage arms sales limitations. Section 218 requires the Secretary of State, in consultation with the Secretary of Defense, to submit to the Congress by June 29, 1977, a report on the effects of the enactment of the AECA 76 on (1) U.S. foreign policy; (2) the

~~CONFIDENTIAL~~-GDS (Declassified on December 31, 1983)

*J* 5/4/97

~~CONFIDENTIAL~~

136

U.S. balance of payments; (3) unemployment in the U.S.; and (4) weapons procurement by the Department of Defense. State has taken the lead in preparing both the President's responses to Section 202 and State's response to Section 218.

The decision process pertaining to PRM 12 and Sections 202 and 218 of the AECA 76 covers the period from June 1976 to May 1977. During that time, a draft Presidential Directive was prepared in response to PRM 12. The responses to Sections 202 and 218 are still being developed.

In the same ten months since the enactment of the AECA 76, a large number of executive branch agencies have been involved in studying and formulating conventional arms transfer policy. In order to facilitate understanding of the process, a flow chart has been developed showing the key players and their relationships, key documents, and the general timing of events. (Figure 1 - next page)

## 2. CHRONOLOGY

### The Decision Process

As can be seen in the chart, the impetus for policy review and formulation came from two sources: the President and the Congress. On June 30, 1976, President Ford signed into law, the AECA 76. During the transition period, the President-elect and his advisers decided to begin a review of international arms transfers immediately after the Inauguration. Thus, PRM 12 was issued on January 26, 1977.

The PRM, which describes the policy area to be studied and the participants, was prepared by the NSC staff with some coordination with State and Defense. The PRC membership for PRM 12 is as shown on the chart. Upon receipt of the PRM, State named Les Gelb as its key staff member for the interagency process. On February 9, 1977, Gelb called a meeting of representatives from all the PRC organizations and the Department of Labor, the Agency for International Development, and the NSC. The EPG requested to participate and was represented by Treasury at this first meeting of the Working Group.

~~CONFIDENTIAL~~

Figure 1

CONVENTIONAL ARMS TRANSFER

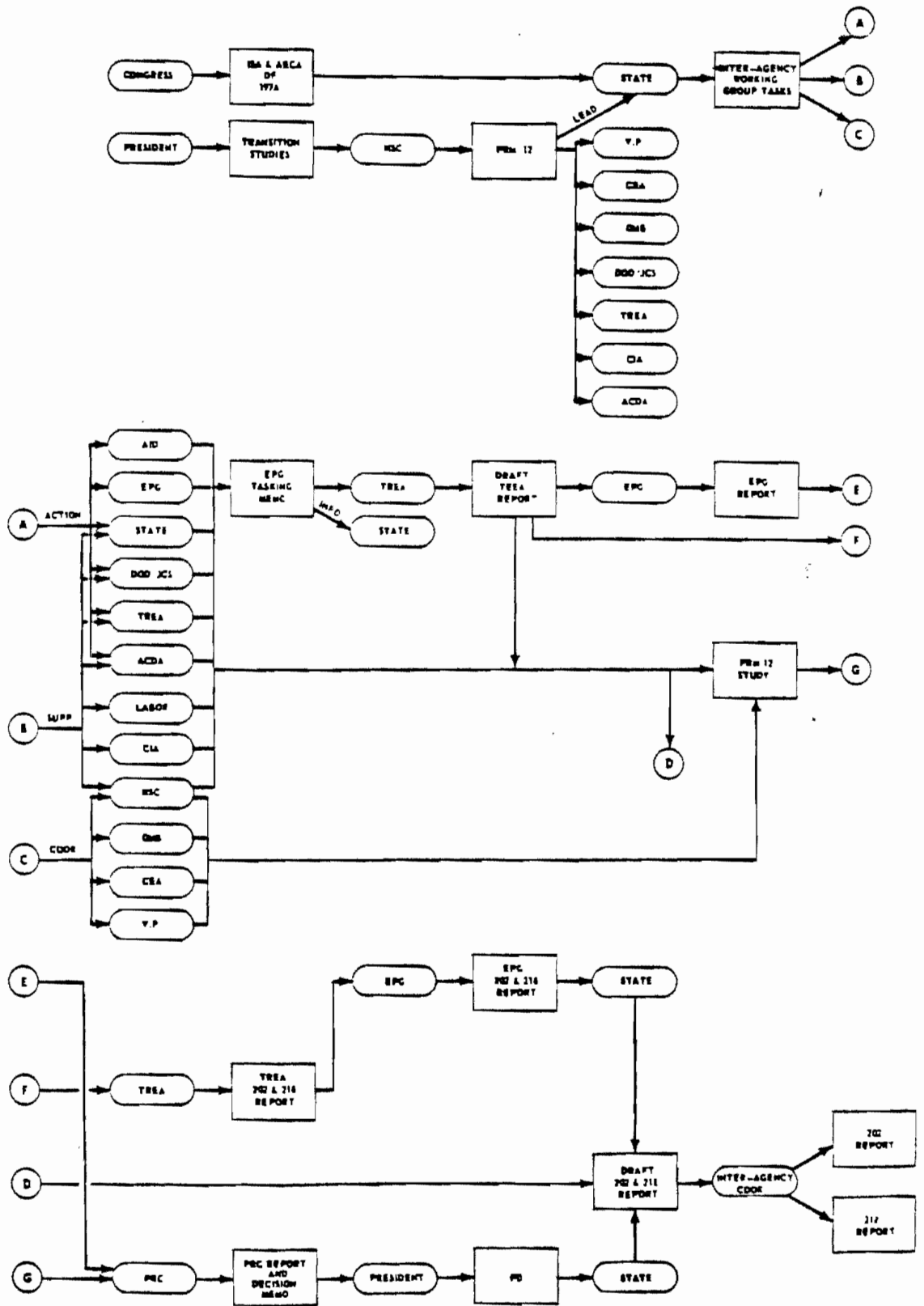

~~CONFIDENTIAL~~

138

At the meeting, Gelb proposed that the Working Group address not only PRM 12, but also the upcoming responses to Section 202 and 218 of the AECA 76. This proposal was accepted and specific tasks were assigned to the organizations indicated for ACTION on the chart. They were to be assisted by various combinations of the organizations indicated by SUPP (support) on the chart. The organizations indicated as COOR (coordination) were not assigned specific tasks, but reviewed the work of the other organizations. The involvement of the EPG, however, differed from that of the other agencies. The EPG served as a review mechanism for the economic aspects of the Working Group report. The EPG re-assigned its task of studying the "impact of options on U.S. economy" to Treasury. Treasury had already received, as a direct task in the Working Group, the responsibility for studying the "impact of arms export control legislation on the U.S. balance of payments, trade with foreign countries, and unemployment." The Working Group report on PRM 12, including the Treasury section, was forwarded to the PRC on April 7, 1977.

On or about April 4, the EPG Working Group representatives requested that Treasury prepare a separate report consolidating all of the economic aspects of the PRM 12 study into a single document for review by the EPG and submittal to the PRC. The report was written by Treasury, edited by the EPG, and sent to the PRC members on April 9, 1977.

On April 12, 28 days after the original PRM 12 deadline, the PRC met and reviewed the efforts of the Working Group and the EPG report. As a result of that meeting the NSC staff members, Jessica Tuchman and Robert Kimmitt, prepared the minutes of the PRC meeting and a decision memorandum which were submitted to the President through Brzezinski on April 13, 1977. The President responded on April 15. Based on the President's reaction to the decision memorandum, the NSC prepared the first draft of the Presidential Directive (PD) which was submitted to the President the same day. The President then directed Brzezinski to discuss the draft PD with Secretary of State Vance and Secretary of Defense Brown. Based on those discussions, the PD was redrafted by Brzezinski and forwarded through the President to Vance on April 25, 1977, for discussions with the Congress. Vance met with the members of the House International Relations Committee and the Senate Foreign Relations Committee on April 26 and 28, respectively. These discussions led to a redrafting of the PD which the

~~CONFIDENTIAL~~

~~CONFIDENTIAL~~

139

President intended to use as a talking paper at the Economic Summit, his meetings with NATO leaders, and others. State began to reshape the efforts of the Working Group to satisfy the requirements for Sections 202 and 218 of the AECA 76.

During the same period, Treasury continued work on rewriting its economic report for inclusion in the Section 202 and 218 reports. The EPG has decided to review the Treasury report before it is submitted to State for the Section 202 and 218 responses. The Treasury reports were distributed for review by the members of the EPG Executive Committee on May 4, 1977; that review is still in progress.

As of the writing of this report, mid-May 1977, the President has not yet issued the Presidential Directive on PRM 12, nor has State completed the Sections 202 and 218 responses. The issuance of the Presidential Directive on Conventional Arms Transfer Policy awaits the President's deliberations with foreign leaders. The events as shown on the flow chart, beyond the submittals of the PRC report and draft Presidential directive to the President, and the Treasury 202 and 218 report to the EPG, represent the expected future course of events.

### 3. COMPLICATING FACTORS

Having described the process to date, this report will now focus on a few of the events which served to complicate the process and forced the 28-day delay in the completion of the PRM 12 study.

a. From the time PRM 12 was issued on January 26, until the meeting of the PRC on April 12, State called upon the President to make a very large number of separate decisions on arms transfers. The decisions involved case-by-case, country-by-country reviews regarding which arms transfer cases had to be released to the Congress as part of the Budget process. While these 49 decisions did not directly influence the efforts of the Working Group, Group members felt that these Presidential decisions, coupled with the concurrent activities on SALT (particularly Vance's trip to Moscow), the Economic Summit, and others, relieved the pressure on the Group to meet the March 15 deadline.

~~CONFIDENTIAL~~

~~CONFIDENTIAL~~

140

b. PRM 12 represents one of the earliest uses of the PRC process and, as such, a number of procedural problems emerged which might be considered inherent in the use of any new process.

c. It was approximately late March before a full-time EPG staff member was available to participate in the Working Group although Treasury did represent EPG in the early going.

d. In submitting his FY 1978 Security Assistance budget to the Congress on March 28, 1977, the President promised to consult with the Congress before making a final decision on arms transfer policy, and thus added another dimension to the process. The staffs, in essence, had to prepare two separate reports: one for the President, and one for the President to use in discussions with Congress. Additionally, since none of the Working Group members were involved in these discussions, communication problems increased.

e. Still another dimension was added when the President decided to confer with a number of foreign governments before deciding on any changes in U.S. arms transfer policy. Again, the staffs had to prepare another report, and again the potential for communication failures increased.

#### 4. ANALYSIS

In general, the conventional arms transfer policy decision process has worked reasonably well. While there is still disagreement over some of the options and recommendations presented to the President, most participants feel that the process allowed a full and open discussion of the issues. However, consensus was not reached in all areas. The major areas of disagreement appear to be over the expected effectiveness of the Arms Export Control Board (AECB) and the extent to which the NSC staff condenses the efforts of the Working Group. In the first instance, a number of

~~CONFIDENTIAL~~

~~CONFIDENTIAL~~

141

Working Group members do not believe that the AECB can effectively oversee the implementation of arms transfer policy. Secondly, a number of participants feel that the use of the PRC minutes and the Decision Memorandum in place of the PRM study report reduces to an unnecessary degree the information provided to the President. On the other hand, the need for information must be balanced with other demands on the President's time. Often, a condensed version of a report is the only efficient means of communicating. Most participants found the NSC staff to be very helpful in interpreting both the PRM and the issues covered from a Presidential perspective.

As with any new process, however, a number of procedural problems arose: organizational responsibilities were confused and sometimes duplicative; participants felt overly pressured by deadlines, etc. These and other problems are examined in the following discussion.

a. No explicit statement clearly identifying the issues involved in the arms transfer area was ever provided to the Working Group. The State Department acted on its own initiative in broadening the PRM 12 study to include Sections 202 and 218 of the AECA 76. The shortcomings in the identification of the issues may have been caused by the relatively short time between the Inauguration and the issuance of the PRM on January 26. On the other hand, State and Defense were the only agencies consulted before the PRM was issued. The failure to include other agencies, such as Treasury, OMB and CEA, clearly limited the perspective of the PRM drafters. While time can be cited as the reason for excluding other agencies in developing PRM 12, there is no indication that agencies such as OMB and CEA have been involved in developing subsequent PRMs. It can be argued, however, that since the PRM only directs a study to be performed and is not a study itself, fuller coordination is not required.

b. No explicit process was defined for conducting the PRM 12 study; neither has a general process been defined for conducting a PRM-directed study. It should be noted, however, that some agencies such as State have developed a general system for handling PRM-directed studies. The lead organization either unilaterally decides on a study approach, as State did for PRM 12, or negotiates one with the NSC staff or other PRC members. In either case, a significant amount of time can be spent attempting to properly organize the study effort. The discussions on issue identification and process definition consumed nearly

~~CONFIDENTIAL~~

~~CONFIDENTIAL~~

142

30 percent of the time originally allocated for the PRM 12 study. Additionally, continued confusion over the issues and the process resulted in two major changes in approach -- issue coverage and policy options -- before the report was finally submitted to the PRC on April 12, 28 days after the original deadline of March 15, 1977. The late submittal prevented the President from meeting a request from the Senate Foreign Relations Committee to submit the Section 202 and 218 reports by April 15, 1977.

c. As with all PRM-directed studies, primary responsibility for the effort changed hands twice during the overall process. The NSC staff was responsible for the PRM until it was approved by the President. Once the PRM was issued, responsibility for conducting the study passed to the lead agency as designated by the President. After the report was submitted to the PRC, responsibility was again placed on the NSC staff. The NSC staff then prepared a report of the PRC proceedings and a decision memorandum for the President.

Problems did and probably will continue to occur as a result of both exchanges. If the agency designated to lead the study was not adequately consulted or informed prior to issuance of the PRM, then confusion over the issues, such as occurred with PRM 12, is likely. Conversely, if the lead agency's approach is contrary to that envisioned by the NSC staff in developing the PRM, the NSC staff is put in the difficult position of trying to influence the lead agency without preempting that agency's authority. Although this difficulty did not occur during the PRM 12 study, both NSC and agency staff members have indicated the existence of this type of problem on other PRM-directed studies.

At the other end of the process, the non-NSC participants felt that the NSC staff took on too much in attempting to prepare the PRC report and decision memorandum on their own. The NSC argument is that line agencies and departments must be excluded from this portion of the process in order to ensure that the final report to the President is uncolored by organizational biases. This argument, however, does not appear to justify the total exclusion of other White House or EOP units which share with the NSC the task of assuring the objectivity of information provided to the President. It is recognized

~~CONFIDENTIAL~~

~~CONFIDENTIAL~~

143

that in some instances participation would of necessity need to be limited, e.g., extremely sensitive or highly classified projects. During either exchange, vertical communication problems such as those mentioned in e. following, can occur. In some instances, these Principal-Subordinate communication problems overshadow the problems caused by changing lead agency responsibilities. Several participants claim that this was the real source of any confusion which developed during the PRM 12 study.

d. The NSC system, in general, is an interagency process with the flexibility to involve any or all executive branch agencies. Nine different agencies were PRM 12 addressees and 12 different agencies were represented on the Working Group.

This comprehensive involvement (see Attachment 1) was not without cost, however. The time consumed in coordination probably increased with the number of agencies. While there is nothing inherently wrong with an increase in coordination time, the increase should not result from needless duplication. The EPG involvement in PRM 12 appears to represent just such a duplication. The primary contribution which EPG made was the editing of the Treasury portion of the PRM 12 and AECA 76 responses before submittal to State. Both of the tasks assigned to the EPG were originally assigned to Treasury, but were reassigned at EPG's request. EPG was attempting to serve as an interagency coordinating body for the economic aspects of the study. However, EPG's function of interagency coordination clearly duplicated that of the PRC. Other than involving Commerce, no addition was made to the players already involved in the process. Additionally, there is no evidence that Commerce's involvement had any affect on the process. The direct participation of CEA, OMB, Treasury, Labor, and AID in the Working Group would appear to have insured proper consideration of the economic aspects of arms transfer policy. In fact, the Treasury treatment of the problem, covered more aspects of the problem than were requested by either State or the EPG.

e. Whenever a very large number of organizations are involved in a project, as in the PRM 12 study, precise role definition and effective communication are essential to efficient operation. The involvement of EPG over-complicated the PRM 12 effort. For example, the OMB participants in the Working Group, OMB/IA, did not know that the EPG was using a

~~CONFIDENTIAL~~



~~CONFIDENTIAL~~

144

different OMB unit to handle the EPG review process. The EPG staff used the OMB/EP because it was their normal point of contact even though they knew who the OMB key staff member was from their participation in the Working Group.

The other major problem in communication involves the failure of principals to adequately inform their Working Group members of decisions made at senior level meetings, such as the PRC meeting. Several Working Group members indicated that their only access to such information during the course of the PRM 12 study was from other Working Group members whose supervisors had kept them informed.

f. The relatively short period originally allotted for the PRM 12 study severely complicated the use of an interagency approach to writing the report. The admittedly unsatisfactory first draft was circulated by State in an attempt to expedite the receipt of comments from other Working Group members. As the deadline for submitting the report neared, however, the process changed. The press of time "forced" State to ignore any changes between the third draft and the final report other than line-in/line-out changes. Substantial efforts of agencies such as AID and ACDA were, therefore, largely ignored because their ideas on issue and option presentation would have required a complete rewrite of the report.

The 28-day slip in the due date did not substantially alter the quality of the inputs from Working Group members. It was largely consumed by State in an attempt either to consolidate the various inputs into an overall report or to accommodate the two major changes in approach mentioned earlier.

Time also affected the process in, perhaps, one further way. A number of participants in the PRM 12 Working Group and in other groups have expressed the feeling that schedules appear to be as important as quality, if not more important. In such an atmosphere, quality is bound to suffer. While this generalization can be applied to nearly anything, it is noted here because of the large number of study participants who specifically mentioned it.

~~CONFIDENTIAL~~

~~CONFIDENTIAL~~

145

g. There is no system for assessing compliance with the PD which will result from the PRM 12 study. Generally speaking, follow-up on any PD is left to the initiative of the NSC staff member who participated in the respective Working Group. While recognizing this shortcoming, the NSC has not established as a firm goal the development of a more formal monitoring process. It has been suggested that in this situation the AECB will perform the monitor role. A formal follow-up process is particularly important in the conventional arms transfer policy area. Without such a process, the benefits of policy formulation will be lost. The President might again be called upon to make country-by-country, weapon-by-weapon decisions on arms transfers. To be meaningful, the policy should clearly distinguish the specific cases which require Presidential attention.

~~CONFIDENTIAL~~

~~CONFIDENTIAL~~

ATTACHMENT 1

PRM 12 TASKS AND TIMETABLE

146

1. TASKING MEMORANDUM FOR PRM 12

<u>Office Responsible for First Draft</u>	<u>Assisted By</u>	<u>Intro- duction</u>	<u>Subject</u>
Defense ISA	ACDA, CIA, State PM		Introduction. Description of Problem, i.e., who sells what to whom. Trend in volume and composition of arms transfers. Trends in release of advanced technology Changes in recipients.
State PM	State S/P, Defense ISA	I.	Role of transfers in U.S. foreign policy and relationship to U.S. political, economic and military interests.
ACDA	State S/P	I(a)	The feasibility and desirability of various unilateral and multilateral initiatives to restrict arms transfers on a national, regional, and global basis.
State PM	State D/HA, Defense ACDA	I(b)	Consideration of such factors as: the type of weapon, equipment, or service being transferred; the role and activities abroad of commercial arms suppliers; third country transfers; transfer of high technology and sensitive items; coproduction; employment of U.S. citizens on defense contracts abroad; and international standards of human rights.
State PM	DOD	I(c)	The feasibility and desirability of restricting all U.S. arms transfers to government-to-government transactions.
State S/P	State PM	I(d)	Issues for decision.
		II(a)	Identification and analysis of basic policy options.

~~CONFIDENTIAL~~

~~CONFIDENTIAL~~

147

<u>Office Responsible for First Draft</u>	<u>Assisted By</u>	<u>Intro duction</u>	<u>Subject</u>
EPG	State EB, Treasury, Labor	II(b)	Impact of options on U.S. economy.
Defense ISA	ACDA	II(c)	Impact on defense readiness and procurement.
State PM	State S/P	II(d)	Impact on U.S. relationship both recipient and supplier States.
		III	Current organizational structure for departmental and interagency considera- tion of arms transfer requests, and options for mechanisms and procedures to provide systematic poli- guidance in the future.
State H	State PM, Defense, NSC	IV	Current relationship between executive and legislative branches in this area, and guidelines and changes necessary for an optimum relationship.
<u>TABS</u> (Unclassified)			
ACDA	Defense, State PM & SP	I.	The risks to world peace from arms sales. (202)
AID	State EB	II.	An evaluation of the impact of U.S. arms sales policies on the economic and social development of foreign countries and consideration of steps which might be taken by the U.S. to encourage the maximum use of the resources of devel- ing countries for economic and social development purposes. (202)

~~CONFIDENTIAL~~

<u>Office Responsible for First Draft</u>	<u>Assisted By</u>	<u>Intro- duction</u>	<u>Subject</u>
<u>TABS</u> (Unclassified cont'd)			
ACDA	Defense	III.	The efforts made by the U.S. during the past five years to initiate and encourage arms sales limitations. (202)
EPG	State EB, Treasury	IV.	The impact of arms export control legislation on the U.S. balance of payments, trade with foreign countries, and unemployment. (218)
Defense	ACDA	V.	The impact of weapons procurement by DOD. (218)

~~CONFIDENTIAL~~

149

2. PROPOSED TIMETABLE FOR PRM 12

February 15	Initial drafts due from agencies
February 17	Initial drafts due from Working Groups
February 18	Draft response to PRM 12 circulated for comment
February 24	Comments on first draft due
February 28	Revised draft with Executive Summary circulated for comment
March 4	Comments due (meeting optional)
March 7	Final draft ready for presentation to principals
March 10	Final submission of agency views (meeting)
March 15	Paper to NSC

~~CONFIDENTIAL~~