

United States Department of the Interior
National Park Service

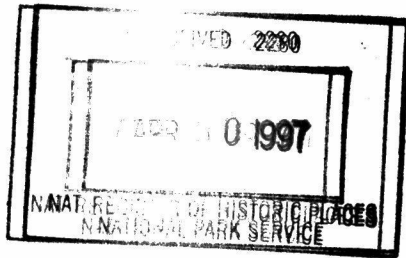

National Register of Historic Places
Registration Form

This form is for use in nominating or requesting determinations for individual properties and districts. See instructions in *How to Complete the National Register of Historic Places Registration Form* (National Register Bulletin 16A). Complete each item by marking "x" in the appropriate box or by entering the information requested. If an item does not apply to the property being documented, enter "N/A" for "not applicable." For functions, architectural classification, materials, and areas of significance, enter only categories and subcategories from the instructions. Place additional entries and narrative items on continuation sheets (NPS Form 10-900a). Use a typewriter, word processor, or computer, to complete all items.

1. Name of Property

historic name Williams, Roger Public School No. 10

other names/site number South Scranton Catholic High School

2. Location

street & number 901 Prospect Avenue N/A not for publication

city or town Scranton N/A vicinity

state Pennsylvania code PA county Lackawanna code 069 zip code 18505

3. State/Federal Agency Certification

As the designated authority under the National Historic Preservation Act, as amended, I hereby certify that this nomination request for determination of eligibility meets the documentation standards for registering properties in the National Register of Historic Places and meets the procedural and professional requirements set forth in 36 CFR Part 60. In my opinion, the property meets does not meet the National Register criteria. I recommend that this property be considered significant nationally statewide locally. (See continuation sheet for additional comments.)

Brent Glass B. Glass, Ex. Dir. April 17, 1997
Signature of certifying official/Title Date

State of Federal agency and bureau

In my opinion, the property meets does not meet the National Register criteria. (See continuation sheet for additional comments.)

Signature of certifying official/Title Date

State or Federal agency and bureau

4. National Park Service Certification

I hereby certify that the property is:

- entered in the National Register.
 See continuation sheet.
- determined eligible for the National Register
 See continuation sheet.
- determined not eligible for the National Register.
- removed from the National Register.
- other, (explain:)

Signature of the Keeper Patrick Andrews Date of Action 6/13/97

5. Classification

Ownership of Property
(Check as many boxes as apply)

- private
- public-local
- public-State
- public-Federal

Category of Property
(Check only one box)

- building(s)
- district
- site
- structure
- object

Number of Resources within Property
(Do not include previously listed resources in the count.)

Contributing	Noncontributing	
1	1	buildings
0	0	sites
0	0	structures
0	0	objects
1	1	Total

Name of related multiple property listing
(Enter "N/A" if property is not part of a multiple property listing.)

N/A

Number of contributing resources previously listed in the National Register

0

6. Function or Use

Historic Functions

(Enter categories from instructions)

EDUCATION/school

RELIGION/school

Current Functions

(Enter categories from instructions)

EDUCATION/college

7. Description

Architectural Classification

(Enter categories from instructions)

LATE VICTORIAN

LATE 19th and 20th CENTURY REVIVALS

Materials

(Enter categories from instructions)

foundation stone

walls brick

stucco

roof asphalt

other

Narrative Description

(Describe the historic and current condition of the property on one or more continuation sheets.)

United States Department of the Interior
National Park Service

National Register of Historic Places
Continuation Sheet

Roger Williams Public School No. 10, Lackawanna County, Pennsylvania

Section number 7 Page 1

Rising two stories from its rusticated stone foundation to its hipped roof, the c. 1896 Roger Williams Public School No. 10 is a typical Late Victorian and Late 19th and 20th Century Revival style school building and consists of one original contributing building and one 1965 non-contributing building. The original building is sited on the corner of Prospect and Beech Streets in a late 19th century, working class neighborhood comprised of modest, two story, frame houses, designed predominantly in the Queen Anne and Late Victorian architectural styles. The original classroom building is I-shaped in massing with a central entrance section, slightly projecting from the top of the "I". The facades are constructed in red brick with encircling brick belt courses which break the monotony of the continuous brick surface. The 1965 addition extends to the east and the north of the original building and is constructed in a similar red brick and contains metal windows and doors. The impact of the addition on the integrity of the original building is minimal as the addition is connected to the original building by a single narrow corridor to the rear of the old school building. Other than this connection point, the original structure is freestanding and independent of the addition which is separated by a lawn to the south and an alley to the east. The original building retains a relatively high degree of integrity. The circulation plan and features of the stairs, corridors and representative classrooms remain, for the most part, completely intact.

The main elevation of the original building faces north and is two stories in height above the raised brown sandstone foundation. The central entrance tower rises three stories from a sandstone base to its hipped roof. The entrance is composed of a molded sandstone, round-headed arch infilled with elaborate grille work transom above a classically-treated frame with side-lights. The transom bar is supported by large scrolled brackets and embellished with dentilated bands. Flanking the opening are cut sandstone decorative plaques set into the masonry at the height of the transom bar. A secondary entrance on Prospect Street also contains an arched opening with original wooden surround flanked by brickwork laid in a wide voussoir band. An original wooden door surround with arched, four-light transom survives, while modern doors have been installed. The Prospect Street elevation is similar to the main elevation in detail, though the attention to symmetry is lessened on this secondary facade as noted by the offset entrance.

Symmetrically oriented wall panels covered with stucco embellish the facades, flanking each window opening at the second story and at the third story of the entrance tower. Fenestration is provided by three window types: the ground floor windows contain 6/6 wooden sashes and the first floor and second floor windows contain paired 4/4 wooden sashes within wood frames with applied brick moldings. Some of the second floor windows contain modern metal sashes in a configuration where the upper light is fixed and the lower is operable. The roofing material has been replaced as asphalt shingles replace the original.

United States Department of the Interior
National Park Service

National Register of Historic Places
Continuation Sheet

Roger Williams Public School No. 10, Lackawanna County, Pennsylvania

Section number 7 Page 2

A landscaped passage separates the original building from the addition which was constructed in 1965. The connecting corridor is set back toward the rear of the original building and was designed so that the new construction intersected only the small projecting appendage to the southeast rear corner of the original building. This allowed for minimal alterations to the original building with the construction of the addition. The major alteration on each floor was the enlarging and lowering of a single window and their conversion to an opening providing a continuous corridor connecting the old and new structures.

To the south of the original building stands the 1965 brick addition, connected to the original building by a narrow corridor section set back a distance from Prospect Street creating a clear separation of the new construction and the original building. With the construction of this addition, Prospect Avenue became the main elevation. The addition is a two and three story red brick building which wraps around the south and east elevations of the original structure. Horizontally oriented aluminum windows which are subdivided into various configurations with aluminum muntins provide natural light to the interior rooms. The Prospect Street entrance is identified by a projecting two story, cast stone trimmed bay which is divided vertically by two cast stone piers to create a simple three door entry. Each doorway is topped by second floor aluminum window. To the south of the main entrance, four stacked windows are set in aluminum frames. Above this register, the second floor is lighted by three simple aluminum windows divided horizontally by muntins into three-light sashes. Metal lettering bears the words "Lackawanna Junior College," illustrating the current use of the facility. The lack of additional fenestration on this elevation responds to the interior usage of this portion of the building as an assembly hall. Secondary entrances provide access at the south end of the building on Prospect Street as well as to the north on Beech Street. These entrances contain double leaf aluminum doors set in aluminum frames with cast stone panels and second story fixed windows above. The remaining elevations are simple brick walls punctuated by bands of horizontally-oriented aluminum windows separated by brick piers lighting each floor.

The interior of the original building is organized along a modified I-shaped axis with a double loaded corridor centered within the building's volume, extending north-south from the main entrance toward the rear. The secondary corridors service the projecting ends which form the head and foot of the "I". The floor plan of the second floor is nearly identical to the first. To the north, the primary stair provides access from the main entrance to the first floor corridor. The entrance is made up of a paneled frame with side-lights topped by a transom with elaborate grille work. The stair is of generous proportions and preserves original beaded board wainscot and plaster walls and ceilings. Two additional stairs providing access from the ground floor to the third floor are also preserved. The stair near the southeast corner retains the original beaded board wainscotting as well as the balustrade and paneled and molded door and window surrounds. The stair in the northwest corner contains metal treads, risers, stringer and balustrade.

United States Department of the Interior
National Park Service

National Register of Historic Places
Continuation Sheet

Roger Williams Public School No. 10, Lackawanna County, Pennsylvania

Section number 7 Page 3

The interior of the original building retains a high degree of integrity. In general, the public spaces such as the stairs and corridors remain in their original condition while the classrooms have had some alterations to certain features and finishes. The corridors are of unusually generous proportions with tall, wide expanses framed by chamfered and beaded plaster arches to either end and are completely furnished with period wainscot, chair rail and transomed doorways with paneled doors providing access to the classrooms. Nearly all of the trim and features, including surrounds, paneled doors, wainscot and offices with side-light windows retain the early stain and varnish finish. Some of the character of first floor corridor has been diminished by the lowered ceiling. However, the essential qualities and features, including the decorative arches, are preserved above the modern intrusions. The second floor corridor is essentially unaltered except for the replacement of a few doors and installation of modern ceiling materials and lighting. To either end of the this corridor, original offices with side-lights and transoms framing the doorways survive. These rooms retain all associated original features including the wainscot, doors, picture rail and molded door and window trim.

Minimal partitioning of the classrooms has occurred and therefore the floor plan remains primarily in its original configuration. Many classrooms have been upgraded with modern finishes such as acoustic tile ceilings, though most classrooms retain vestiges of original beaded board wainscotting, original chalkboards and other trim features. Several classrooms and offices preserve the full compliment of wainscot, chalkboards, molded door and window surrounds, paneled doors and picture rail. Original varnished window trim remains at the locations of all original windows. The interior trim was removed from the openings that were altered with the installation of the modern windows on the second floor.

The first floor of the addition is essentially "L" shaped in plan with a narrow wing of classrooms accessed off a single loaded corridor extending from the north entrance, leading to the gymnasium. The plan of the second floor is nearly identical. The interior of the addition contains features and finishes typical to the period. Corridors generally contain linoleum floors, drywall and exposed cinderblock walls often lined with metal lockers, and acoustic tile ceilings. All stairs contain metal treads, risers, stringer and balustrade. The walls of the stairs are cinderblock. The classrooms are primarily finished with exposed cinderblock walls, acoustic tile ceilings and linoleum floors. Windows are recessed into the wall and there is no applied window trim. The gymnasium contains a wooden floor, cinderblock walls and an exposed metal beam ceiling. Directly above the gymnasium is the auditorium which contains a linoleum floor, cinderblock walls and acoustic tile ceiling.

The Roger Williams School Public School No. 10 retains the form and the essential design elements that characterize the late 19th/early 20th century school building. The 1965 addition is accessed by a single narrow connecting corridor and has minimal visual impact on the historic building. The Roger Williams Public School No. 10 stands in good condition as a representative example of the

**United States Department of the Interior
National Park Service**

**National Register of Historic Places
Continuation Sheet**

Roger Williams Public School No. 10, Lackawanna County, Pennsylvania

Section number 7 Page 4

characteristics and features which were typical in school building architecture of the period. It is also the best preserved example in the Scranton area of this once common building type.

United States Department of the Interior
National Park Service

National Register of Historic Places
Continuation Sheet

Section number 7 Page 5

SITE PLAN

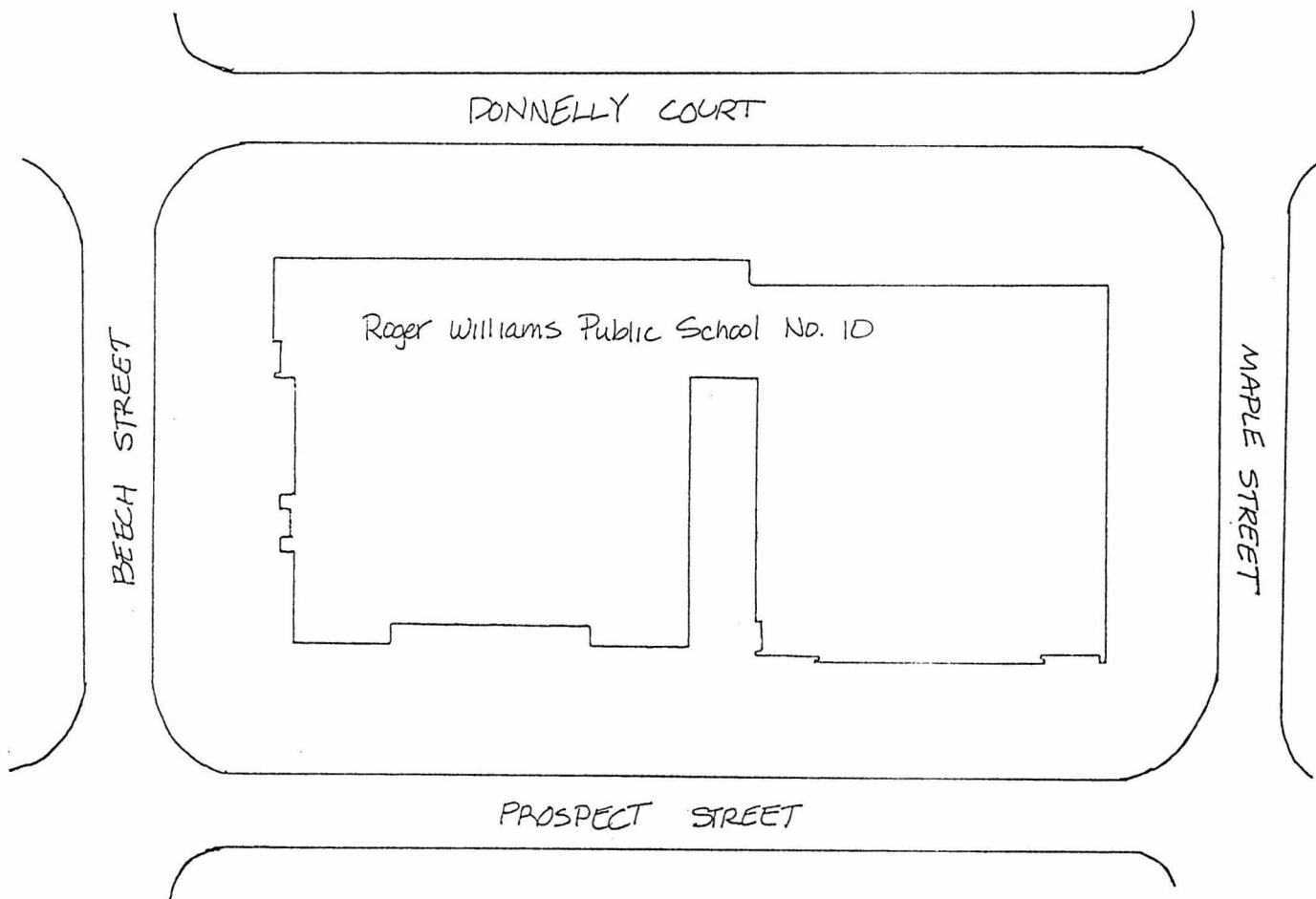

← N

United States Department of the Interior
National Park Service

National Register of Historic Places Continuation Sheet

Section number 7 Page 6

FIRST FLOOR PLAN

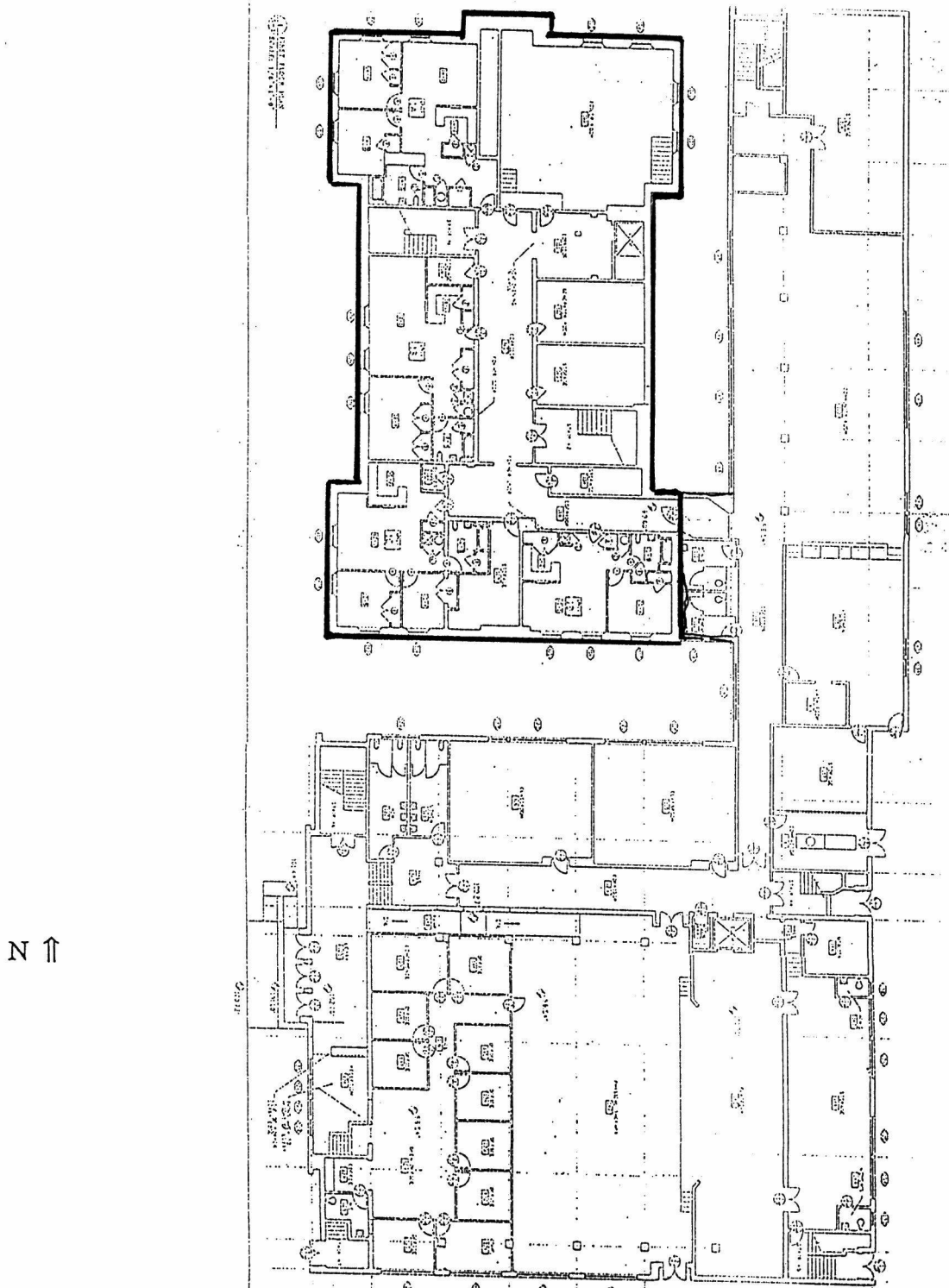

United States Department of the Interior
National Park Service

National Register of Historic Places Continuation Sheet

Section number 7 Page 7

SECOND FLOOR PLAN

N ↑

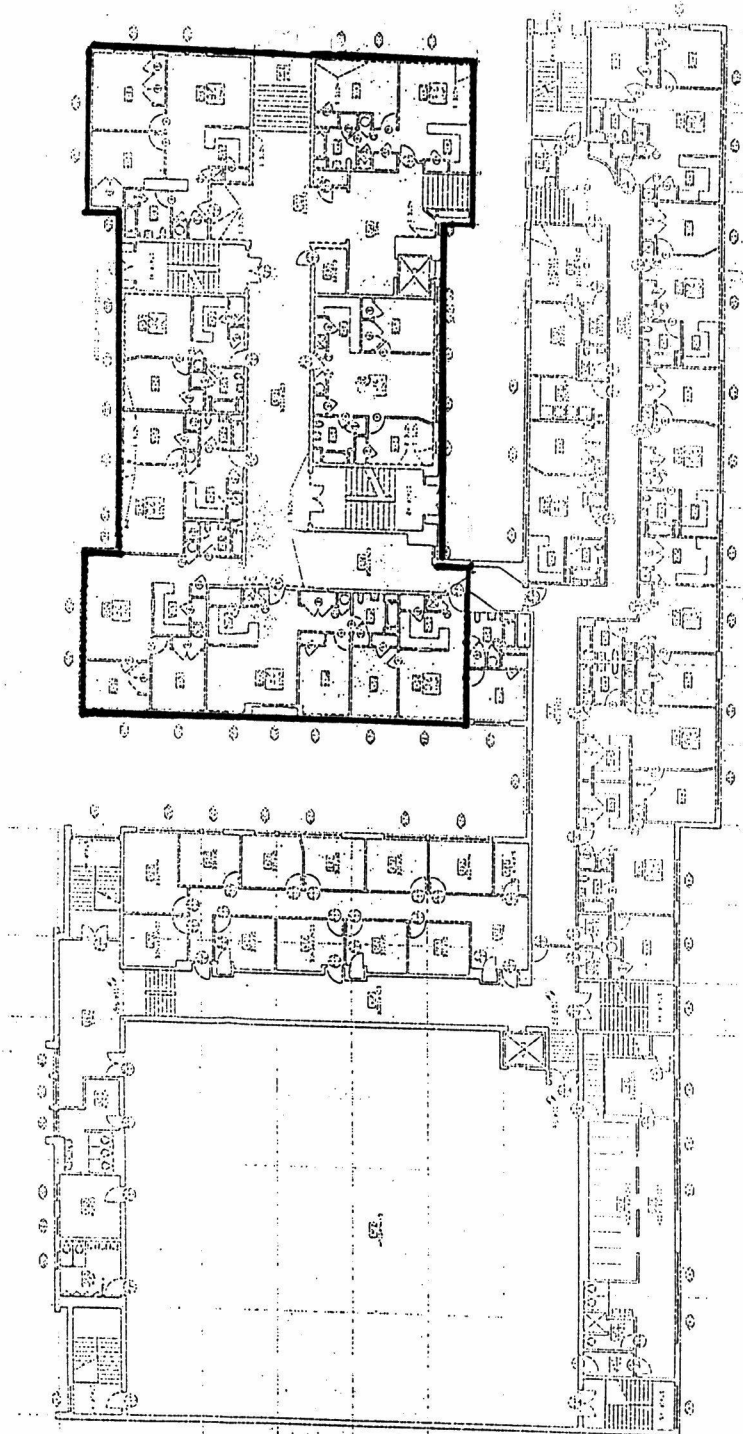

United States Department of the Interior
National Park Service

National Register of Historic Places Continuation Sheet

Section number 7 Page 8

THIRD FLOOR PLAN

N ↑

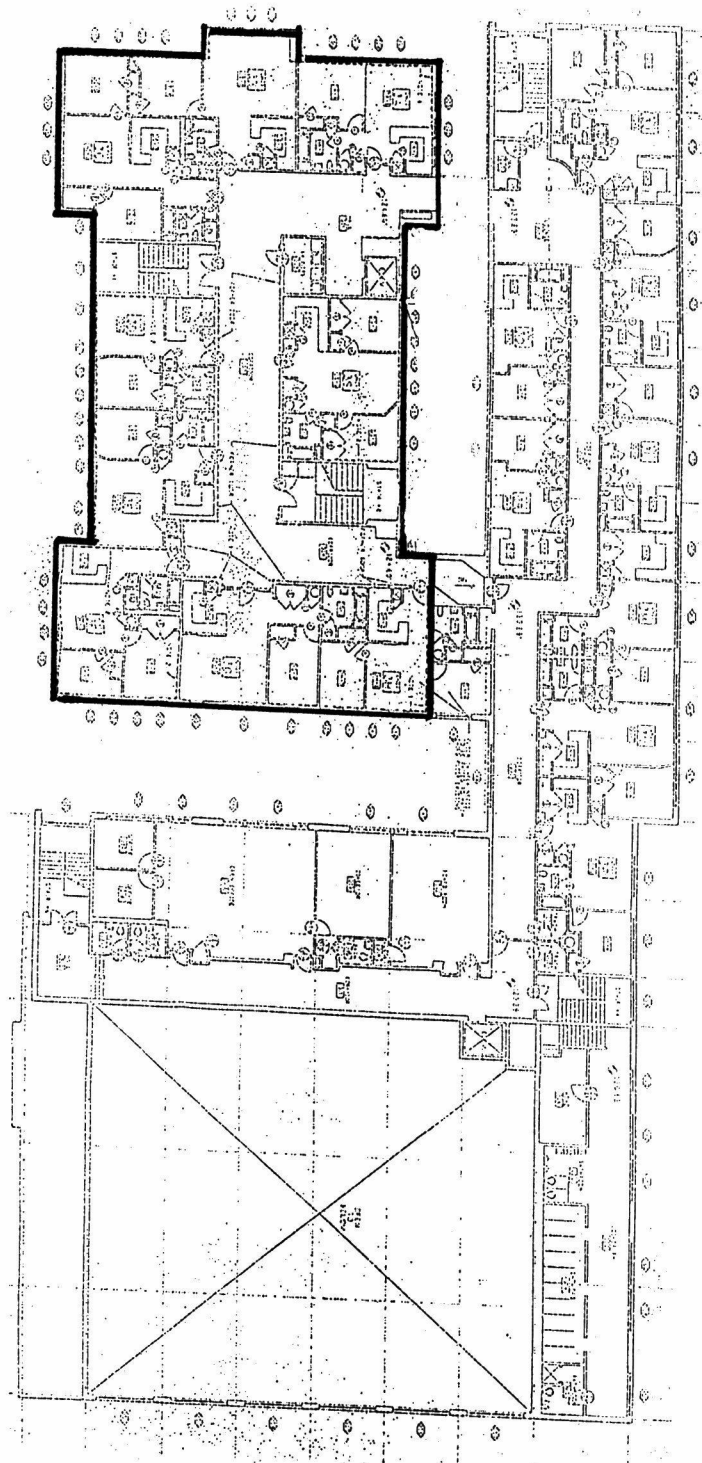

United States Department of the Interior
National Park Service

National Register of Historic Places Continuation Sheet

Section number 7 Page 9

PHOTOGRAPH KEY

N ↑

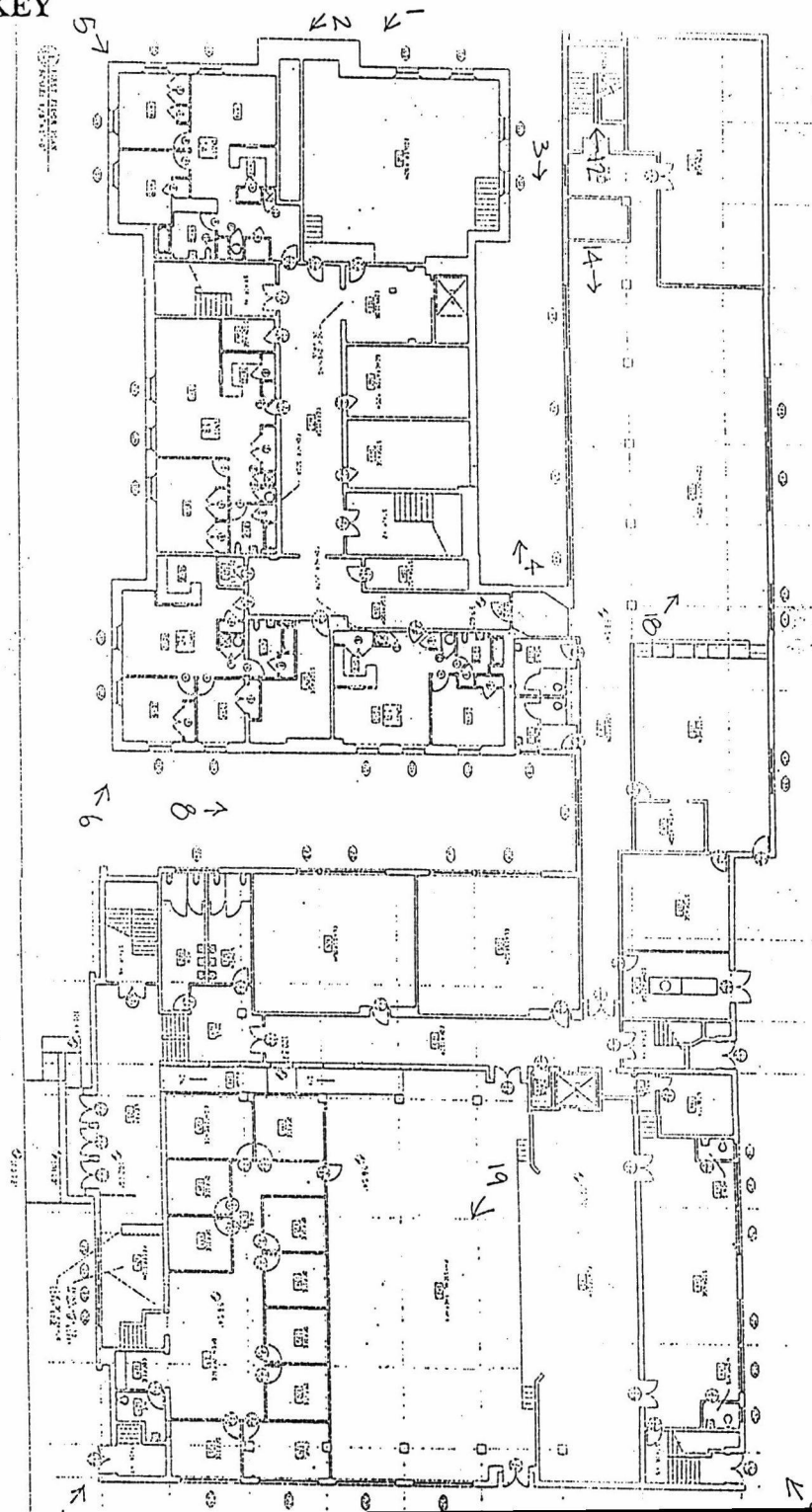

United States Department of the Interior
National Park Service

National Register of Historic Places Continuation Sheet

Section number 7 Page 10

PHOTOGRAPH KEY

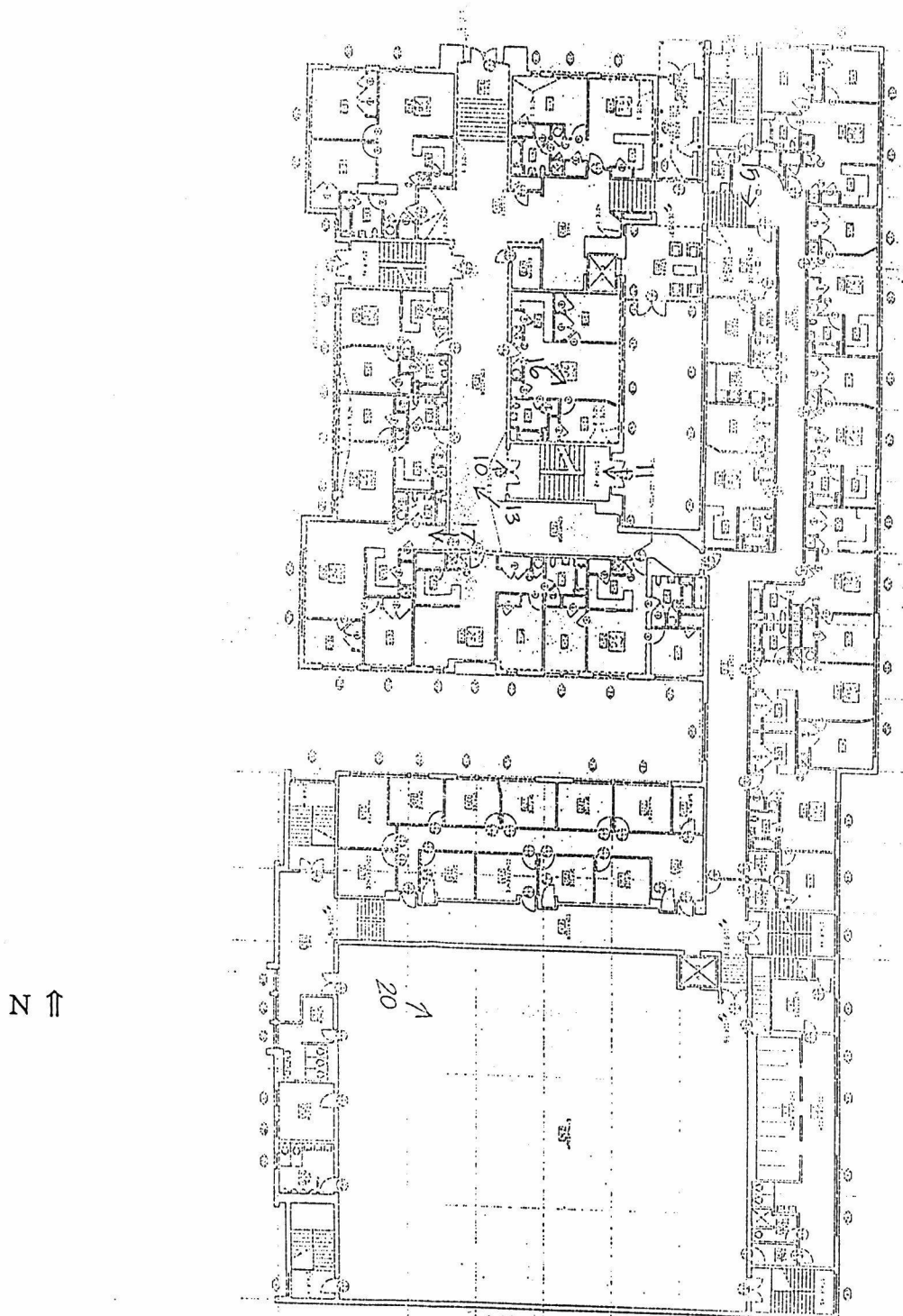

8. Statement of Significance

Applicable National Register Criteria

(Mark "x" in one or more boxes for the criteria qualifying the property for National Register listing.)

- A** Property is associated with events that have made a significant contribution to the broad patterns of our history.
- B** Property is associated with the lives of persons significant in our past.
- C** Property embodies the distinctive characteristics of a type, period, or method of construction or represents the work of a master, or possesses high artistic values, or represents a significant and distinguishable entity whose components lack individual distinction.
- D** Property has yielded, or is likely to yield, information important in prehistory or history.

Criteria Considerations

(Mark "x" in all the boxes that apply.)

Property is:

- A** owned by a religious institution or used for religious purposes.
- B** removed from its original location.
- C** a birthplace or grave.
- D** a cemetery.
- E** a reconstructed building, object, or structure.
- F** a commemorative property.
- G** less than 50 years of age or achieved significance within the past 50 years.

Areas of Significance

(Enter categories from instructions)

Education

Architecture

Period of Significance

1896-1941

Significant Dates

1896

Significant Person

(Complete if Criterion B is marked above)

N/A

Cultural Affiliation

N/A

Architect/Builder

unknown

Narrative Statement of Significance

(Explain the significance of the property on one or more continuation sheets.)

9. Major Bibliographical References

Bibliography

(Cite the books, articles, and other sources used in preparing this form on one or more continuation sheets.)

Previous documentation on file (NPS):

- preliminary determination of individual listing (36 CFR 67) has been requested
- previously listed in the National Register
- previously determined eligible by the National Register
- designated a National Historic Landmark
- recorded by Historic American Buildings Survey # _____
- recorded by Historic American Engineering Record # _____

Primary location of additional data:

- State Historic Preservation Office
- Other State agency
- Federal agency
- Local government
- University
- Other

Name of repository:

Scranton Public Library, Lackawanna
County Historical Society

Roger Williams Public School No. 10
Name of Property

Lackawanna County, Pennsylvania
County and State

10. Geographical Data

Acreage of Property 1 acre

UTM References

(Place additional UTM references on a continuation sheet.)

1

1	8
---	---

4	4	4	3	4	0
---	---	---	---	---	---

4	5	8	2	5	0	0
---	---	---	---	---	---	---

Zone Easting Northing

3

--	--

--	--	--	--	--	--

--	--	--	--	--	--	--	--

Zone Easting Northing

4

--	--

--	--	--	--	--	--

--	--	--	--	--	--	--	--

See continuation sheet

Verbal Boundary Description

(Describe the boundaries of the property on a continuation sheet.)

Boundary Justification

(Explain why the boundaries were selected on a continuation sheet.)

11. Form Prepared By

name/title Cynthia A. Rose/Associate

organization Noble Preservation Services, Inc. date 24 May 1996, revised 6 September 1996

street & number 10 Log House Road telephone (215) 679-5110

city or town Zionsville state PA zip code 18092

Additional Documentation

Submit the following items with the completed form:

Continuation Sheets

Maps

A **USGS map** (7.5 or 15 minute series) indicating the property's location.

A **Sketch map** for historic districts and properties having large acreage or numerous resources.

Photographs

Representative **black and white photographs** of the property.

Additional items

(Check with the SHPO or FPO for any additional items)

Property Owner

(Complete this item at the request of SHPO or FPO.)

name Lackawanna Junior College

street & number 901 Prospect Avenue telephone _____

city or town Scranton state PA zip code 18505

Paperwork Reduction Act Statement: This information is being collected for applications to the National Register of Historic Places to nominate properties for listing or determine eligibility for listing, to list properties, and to amend existing listings. Response to this request is required to obtain a benefit in accordance with the National Historic Preservation Act, as amended (16 U.S.C. 470 *et seq.*).

Estimated Burden Statement: Public reporting burden for this form is estimated to average 18.1 hours per response including time for reviewing instructions, gathering and maintaining data, and completing and reviewing the form. Direct comments regarding this burden estimate or any aspect of this form to the Chief, Administrative Services Division, National Park Service, P.O. Box 37127, Washington, DC 20013-7127; and the Office of Management and Budget, Paperwork Reductions Projects (1024-0018), Washington, DC 20503.

United States Department of the Interior
National Park Service

National Register of Historic Places
Continuation Sheet

Roger Williams Public School No. 10, Lackawanna County, Pennsylvania

Section number 8 Page 1

Roger Williams Public School No. 10 was constructed c. 1896 and is located at the corner of Prospect Avenue and Beech Streets in ward nineteen on Scranton's "South Side," south of the Lackawanna River which divides the city from the southwest to the southeast. The building stands as an important institutional landmark within its community. The building stands in form and detail as an example of the Late Victorian and Late 19th and 20th Century Revival architectural style, exhibits a high degree of integrity and is significant for its success in the education movement.

Summary History

Public education as it is known today did not exist in Pennsylvania or in the United States until the last quarter of the eighteenth century. From the onset a stigma was attached to public education, a system originally intended to educate the poor. Private schools were the more accepted convention for those with adequate means¹. While organized efforts were underway to establish public schools in Scranton as early as the late eighteenth century, it was not until well into the nineteenth century that the institution became ensconced.

Early schools were generally one room buildings with entirely inadequate furnishings, lighting, sanitation and heating. In 1818 Scranton's first schoolhouse was constructed in what is known as North Scranton². The mid-nineteenth century brought about legislation that revolutionized school building architecture. One of the most prevalent consequences of these legislative mandates was the separation of schools by grades. Following this move, it was decided that consolidation of Scranton's four districts into one larger district would be more effective and in 1874 the City of Scranton School District was inaugurated.³ This was the impetus for the construction of the larger classroom buildings recognizable as the modern school building. Individually, the districts did not have the means to erect adequate buildings. With the advent of the consolidated district, all taxes were paid into a common fund. The small one room schoolhouses were abandoned in favor of the modern well lighted, heated

¹ Thomas Murphy, *Jubilee History. Commemorative of the Fiftieth Anniversary of the Creation of Lackawanna County, Pennsylvania* (Topeka, KS:Historical Publishing Co., 1928), 201. This is considered one of the most complete histories of the county. Chapter X discusses, at length, the developing educational system in the county, specifically in Scranton. Murphy provides some information on the nineteenth century government legislation.

² Murphy, 207.

³ Col. Frederick L. Hitchcock, *History of Scranton and Its People* (New York:Lewis Historical Publishing Co., 1914), 339. Murphy's and Hitchcock's histories are considered to be the most complete sources of information on the nineteenth and early twentieth century history of Scranton. Hitchcock's chapter on educational institutions provides a detailed account of the persons who shaped Scranton's educational system.

United States Department of the Interior
National Park Service

National Register of Historic Places
Continuation Sheet

Roger Williams Public School No. 10, Lackawanna County, Pennsylvania

Section number 8 Page 2

and ventilated classroom buildings.

Scranton's south side was laid out prior to 1877 as a map of this date portrays the entire nineteenth ward as an expanse of blocks designed in the same style with three alleys per block forming an "H" centered within each block⁴. Development was, however, sporadic with considerably less than half of the lots in the ward developed and with virtually no development toward the south. Some of the south side's industries during the 1870s included the Stafford Brook Coal Co., Scranton Silk Co., Sauquoit Silk Co., Lackawanna Mills and the Lackawanna Iron and Coal Co. The Lackawanna Iron and Coal Co. owned a significant stretch of blocks in the south side which they later cleared and developed as the railroad yard. This railroad yard served the Delaware, Lackawanna and Western Railroad with lines continuing from Scranton to New York and Buffalo.

The south side neighborhood was comprised of a variety of ethnic groups. Historic maps depict two nearby churches, the Sacred Heart Polish Roman Catholic Church and the German Methodist Church. This was a working class neighborhood made up of small, predominantly two-story frame buildings that housed workers employed at the local industries.

An 1877 map portrays a "Public School" at the site of the existing building. This building is clearly not the current building, but demonstrates that this lot was designated for public school use from the onset. The footprint portrayed on the map is a T-shaped building, significantly smaller than the existing c. 1896 building, and is set in from the streets, occupying only lots 2 and 3. The existing c. 1896 building occupies lots 1-4. This earlier building was also known as Public School No. 10 as documented in an 1891 city directory.⁵

Census records show that in 1880 the population of Scranton was 45,850, while in 1890 it jumped to 75,215 and in 1900 it rose to 102,026. This substantial rise in population was most likely due to the boom in industry, specifically in the anthracite coal, iron, railroad and textile industries, which was transforming Scranton and causing an influx of immigrant workers. This rise in population would not only necessitate the need for schools in new locations but the need for the renovation or demolition of old school buildings. This would explain why the previously existing school building was demolished and the new building immediately erected, as only one additional school served the neighborhood at this time, Public School No. 8, which is shown only a few blocks from Prospect and Beech Streets.

⁴ *City Atlas of Scranton, PA* (Philadelphia:G.M. Hopkins, CE, 1877).

⁵ *Taylor's Scranton City Directory* (Scranton:Taylor Publishing, 1891).

United States Department of the Interior
National Park Service

National Register of Historic Places
Continuation Sheet

Roger Williams Public School No. 10, Lackawanna County, Pennsylvania

Section number 8 Page 3

By 1880 Scranton had twenty-nine schools in its district, sixteen of which were of brick construction and the remaining of frame construction. Scranton's industries were flourishing, most notably, the coal, silk and railroad industries. The 1880s and 1890s brought a great population boom to Scranton and the rise in school age children coupled with the fact that most of the city's schools were in poor condition, contained unsuitable furniture, lacked blackboards and textbooks and had less than sanitary conditions, precipitated the erection of many new school buildings. In 1885 and 1886 no less than twenty-two new schools were built in the county.⁶

A Scranton school district handbook for the years 1885-86 lists Public School No. 10 (the earlier building) as containing 386 students in grades 1-9 and nine teachers.⁷ The manuals for the years 1888-89 and 1895 lists comparable figures. The existing c. 1896 building contains significantly more than nine classrooms, hence the figures suggest that the earlier building stood until after 1895. The existing building was completed by 1898, as the 1898 atlas clearly depicts the I-shaped footprint of the building, so it may be inferred that construction began between 1896 and 1898, therefore a circa date of 1896 was selected.⁸

In September 1916, many of the schools in the district were renamed using names of notable Americans. Public School No. 10 was one of the schools renamed in 1916 and was given the name Roger Williams Public School No. 10, after the 17th century American religious leader who fled Massachusetts to escape persecution for his criticism of Puritanism.⁹ In 1636, Williams founded Providence, a community based on religious freedom and democratic ideals, and in 1663 he obtained a royal charter for his new colony which would later become the state of Rhode Island.¹⁰ Other area schools were named after such renowned Americans as Harriet Beecher Stowe John G. Whittier,

⁶ Murphy, 203.

⁷ *Manual and Course of Study of the Public Schools of Scranton, Pennsylvania* (Scranton: The Republican Print, 1885-86). A series of school manuals are located in the collection of the Lackawanna County Historical Society. These manuals address the curriculum, rules and regulation, significant administrative persons and certain statistics on the district's buildings.

⁸ *Atlas of Surveys of the City of Scranton* (Philadelphia: Graves and Steinbarger, 1898). This is the earliest atlas to definitively illustrate the existing building. This is a highly detailed atlas providing the names of the property owners and the footprints of the structures.

⁹ Telephone interview with Pat McCabe, Assistant Superintendent of the Scranton Public Schools Administration, January 27, 1997.

¹⁰ *The American Heritage Dictionary of the English Language* (New York: Houghton Mifflin Company, 1992), Third Edition, 2043.

United States Department of the Interior
National Park Service

National Register of Historic Places
Continuation Sheet

Roger Williams Public School No. 10, Lackawanna County, Pennsylvania

Section number 8 Page 4

James Monroe and Daniel Webster.

Scranton's Public School No. 10 was a successful educational facility into the mid-twentieth century, yet it appears that lack of enrollment may have forced the school to close in 1941. It has been estimated by the State Planning Board that from the 1940 census to August 1, 1942, the Lackawanna County population decreased by 28,026 as a result of the availability of jobs in war plants out of town.¹¹ This decrease would account for a lack of enrollment in the public schools which would have led to the closing of the Roger Williams School in 1941.

In 1941 Bishop William J. Hafey purchased the property with the intention of opening South Scranton Catholic High School. With the ensuing World War, Bishop Hafey's plans were delayed for six years and the building was used as a factory to manufacture wartime goods. A Sanborn Map dating to 1941 lists the building as "Prospect Industries."¹² While city directories continue to list the building as the Roger Williams School during the war and through 1947, in the city directory for 1942-43, the building is listed as vacant.

Prior to 1947 all secondary Catholic schools in the area were private or parish supported. Bishop William Hafey had studied the centralized system of high schools in Allentown and was confident that this system would be effective for Scranton.¹³ In that same year, the building housing Saint John the Evangelist, a nearby school, was declared a fire hazard and the diocese was ordered by the Scranton Fire Department to abandon the facility. It was decided to relocate into Public School No. 10 for the fall 1947 term, and with this move, the centralized Catholic system was instated.

Following World War II, schools throughout the country began a movement to improve the physical condition of school buildings. Among the most prevalent improvements was the upgrading of rooms for gym, home economics, shop, art and music. This movement, coupled with steadily increasing enrollment at South Catholic brought the need for additional classroom space and in 1952 classroom space was utilized in the nearby Nativity School. Five years later the school was recognized as a leader in secondary education. Enrollment had grown to 498 students, with 21 teachers.¹⁴ By 1962

¹¹ No author cited, "Scranton in the Past: 20 Years Ago, Sept. 2, 1943," *Scranton Times* (September 2, 1963).

¹² *Insurance Maps of Scranton* (New York:Sanborn Co. Map, 1941). This map was updated to 1949 and shows "Southside Catholic High School" on the site. This notation was pasted over an earlier 1941 notation which read "Prospect Industries."

¹³ Joseph Nieroda, "High School is Advanced Into History," *Sunday Times* (June 20, 1982).

¹⁴ Nieroda.

United States Department of the Interior
National Park Service

National Register of Historic Places
Continuation Sheet

Roger Williams Public School No. 10, Lackawanna County, Pennsylvania

Section number 8 Page 5

it was apparent that the success of the school had reached far beyond the building's capacities. In February 1963 it was announced that a \$600,000 building expansion program was endorsed by the diocese. Three residential buildings on the 900 block of Prospect Avenue were purchased and razed for the erection of the addition.¹⁵ Ground-breaking ceremonies were held on September 20, 1964 and the cornerstone was laid on September 11, 1965.¹⁶ The addition included 23 classrooms, science laboratories, a gymnasium and an auditorium.

In June 1973 it was decided to rename South Catholic in honor of Bishop Klonowski. The school was called Bishop Klonowski High School. Declining enrollment and increasing expenses plagued the school for the next decade and in June 1981 it was decided to merge with Bishop Hannan High School. Within one year the school was forced to permanently close.¹⁷ Lackawanna Junior College purchased the property in June 1982 and began occupation in August of that year.

Architectural Significance

Roger Williams Public School No. 10 retains the essential design elements that characterize the Late Victorian and Late 19th and 20th Century Revival styles, with distinctive elements representing numerous styles. Its form and massing are clearly Victorian. The entrance tower is reminiscent of the Italianate. Its massive arched entrances embody the Romanesque Revival style. Conceivably, the building was once roofed in a clay tile representing the Mission or Spanish Revival. The stucco panels also speak of the mission style, though seemingly these have been altered. Constructed at the turn of the century, on the cusp of the Victorian and Revival architectural movements, this building contains the representative features that define this period of reformation in architecture.

The 1898 *Atlas of Surveys of the City of Scranton* illustrates that by 1898 the Scranton Public School District had erected a massive, high style Victorian high school in the heart of the center city.¹⁸ Each neighborhood, however, contained a much more modest two or two-and-one-half story brick elementary school building that served the local community. Seemingly, the school district had established some sort of formula for these buildings as they contained remarkably similar size and

¹⁵ Sister Zita Maria Kane, "Bishop Klonowski High School" (Scranton, PA:Sisters of IHM, 1982), 17.

¹⁶ Ibid.

¹⁷ Earley, 228.

¹⁸ *Atlas of Surveys of the City of Scranton* (Philadelphia: Graves and Steinbarger, 1898).

United States Department of the Interior
National Park Service

National Register of Historic Places
Continuation Sheet

Roger Williams Public School No. 10, Lackawanna County, Pennsylvania

Section number 8 Page 6

massing characteristics. The schools were generally sited on corner lots, though a few were located in the middle part of the block, and all buildings contained modest lots with narrow strips of lawn area around the perimeters of the buildings. Comparison of the footprints of the buildings depicted on the 1898 atlas reveals that the schools were extraordinarily similar with heavy central massing, perhaps due to spacial limitations on the blocks. The architect of Public School No. 10 is unknown, however, it is likely that it may have been either a staff architect or a local architect. It is unknown at what point the school district employed staff architects, but it was likely sometime around 1885-86 when the school construction boom occurred.

In total, aside from the main high school, there were nineteen public schools on the southeast side of the Lackawanna River in 1898. The numbering of the schools was rather sporadic and included numbers 2-8 (including two number threes and two number fours), numbers 10, 15, 27, 28, 34, one small neighborhood "High School" and three unnumbered "Public Schools" (one of which was determined to be another number 8). Of these nineteen, only seven survive including numbers 3, 4, both no. 8s, 10, 15, 27.

Of these surviving seven, one School No. 8 and School No. 15 are the most comparable to Roger Williams Public School No. 10 in architectural style. The School No. 8 retains its overall integrity while No. 15 has lost much of its integrity.

School No. 8, located on the northwest corner of Wyoming and Ash Streets, is a two-and-one-half story, neo-classical, brick building with a raised stone foundation. Its massing is essentially square in plan with a slightly projecting entrance. The first story of the projecting entrance section is constructed of a rusticated stone with a central, arched entrance opening. This section is crowned by a dentilated pediment with a single oval window. Barrel vaulted dormers project from the hipped roof and contain paired 1/1 sashes. All windows on the lower floors contain 1/1 sashes. A louvered ventilation tower, roofed in an inverted bell shaped configuration projects from the center of the roof. The building retains its overall integrity on the exterior, though it has been converted to a health care center and may have been substantially altered on the interior.

Public School No. 15, located on the southwest corner of Locust and Webster Streets, a few blocks from Public School No. 10, is a hipped roof brick building rising two stories over a raised stone foundation. Its arched entrance is further denoted by a slightly projecting, three story, pedimented tower section centered on the main facade. A single circular window opening lights the third story at the pediment. All other windows have been substantially altered with modern sashes set into the partially infilled original openings. A wide, modern stucco band encircles the facades between the first and second stories, that may have altered the original detailing. School No. 15 was built in 1897 and designed by a prominent local architect, John A. Ducksworth. Among his many local

United States Department of the Interior
National Park Service

National Register of Historic Places
Continuation Sheet

Roger Williams Public School No. 10, Lackawanna County, Pennsylvania

Section number 8 Page 7

commissions were the Coal Exchange Building, Carbondale Public School, Dunmore High School, Plymouth Church in Hyde Park and Public Schools 6, 7, 13, 25 and 28.¹⁹ School No. 15 has lost its architectural integrity with the loss of the original windows and the extensive stuccoing campaign.

Public School No. 3 may no longer survive or if it does survive, it has been significantly altered and is incorporated into a religious complex that includes a church, rectory and school. Public School No. 27 is made up of three separate builds and significant alterations have occurred which have substantially compromised its integrity. The remaining school numbers 4 and the other number 8 were designed in different architectural styles from No. 10 and have had significant window alterations.

At the time of construction in c. 1896, the Roger Williams School was designed in the style and with the typical features and characteristics of school buildings throughout the Scranton School District. Surviving district schools from the period are strikingly similar in form and detail, though they do not retain the integrity demonstrated in School No. 10. The form of these buildings is remarkably comparable, generally massive blocks with projecting three story entrance towers. Paneled wooden doors with transoms and beaded board wainscoting were typical interior finishes for turn of the century school buildings. The Roger Williams School No. 10 conformed with the programmatic design paradigm that the Scranton School District had evidently established and stands with a high degree of architectural integrity.

Educational Significance

Roger Williams Public School No. 10 is an important education landmark in its community. The southeast corner of Prospect and Beech Streets was the site of a public school as early as the mid-nineteenth century as documented on period atlases. Public School No. 10 was constructed c. 1896 and the building remained a successful facility operated by the Scranton School district for a half-century.

Schools of this period demonstrate the implementation of education reform ideas that had evolved in the mid to late nineteenth century, such as the separation of schools by grades, the newly developed centralized districts, and the need for improved facilities. At its inception, the school exclusively served the local, ethnic, working class neighborhood. As Scranton's population continued to grow, the turn of the century school facilities no longer had the capacity to serve the increasing enrollment

¹⁹ *Taylor's Scranton City Directory* (Scranton: Taylor Publishing, 1898).

United States Department of the Interior
National Park Service

National Register of Historic Places
Continuation Sheet

Roger Williams Public School No. 10, Lackawanna County, Pennsylvania

Section number 8 Page 8

and the district began to abandon these facilities for large schools that served multiple neighborhoods.

Roger Williams Public School No. 10 represents the evolution of the early public education philosophies and the manifestation of these ideas in school facilities. Public School No. 10 is an important institution in the neighborhood and has attained citywide importance as one of a few remaining late nineteenth century public schools.

The Roger Williams Public School No. 10 embodies great local significance as the site of an important institutional landmark that was designated for public educational use from Scranton's earliest occupation, served its community as one of its earliest elementary schools. Relatively few of the once common neighborhood elementary schools which served the Scranton School District survive. Of the surviving seven, only a handful retain their architectural integrity and stand as representative examples of this important building type. The building stands in good condition with the design elements that characterize the Late Victorian and Late 19th and 20th Century Revival styles and thus meets the National Register criteria A and C.

United States Department of the Interior
National Park Service

National Register of Historic Places
Continuation Sheet

Roger Williams Public School No. 10, Lackawanna County, Pennsylvania
Section number 9 Page 1

BIBLIOGRAPHY

The American Heritage Dictionary of the English Language. New York: Houghton Mifflin Company, 1992. Third Edition.

Atlas of the City of Scranton. Philadelphia: L.J. Richards and Co., 1888.

Atlas of the City of Scranton and Borough of Dunmore. Philadelphia: Volk and Kuehls, 1918.

Atlas of Surveys of the City of Scranton. Philadelphia: Graves and Steinbarger, 1898.

City Atlas of Scranton, PA. Philadelphia: G.M. Hopkins, CE, 1877.

Earley, James B. *Envisioning Faith. The Pictorial History of the Diocese of Scranton*. Devon, PA: William T. Cooke Publisher, 1994.

Hitchcock, Col. Frederick L. *History of Scranton and Its People*. New York: Lewis Historical Publishing Co., 1914.

Insurance Maps of Scranton. New York: Sanborn Co., 1941 updated to post-1965.

Insurance Maps of Scranton. New York: Sanborn Map Co., 1956.

Kahriger, Tom. "Lamberti Had Vision and Now It's Clear." No other bibliographic information cited. Miscellaneous file at the Lackawanna County Historical Society.

Kane, Zita Maria. "Bishop Klonowski High School." Sisters of IHM, Scranton, Pennsylvania. 1982.

"LJC Moving On To Bigger Things." (April 1982). No other bibliographic information available. Located in the newspaper clipping files at the Lackawanna County Historical Society.

"LJC Will Expand in New Facilities." *Scrantonian* (March 14, 1982).

Manual and Course of Study of the Public Schools of Scranton, Pennsylvania. Scranton: Gerlock and Davis, 1888-89.

United States Department of the Interior
National Park Service

National Register of Historic Places
Continuation Sheet

Roger Williams Public School No. 10, Lackawanna County, Pennsylvania

Section number 9 Page 2

Manual and Course of Study of the Public Schools of Scranton, Pennsylvania. Scranton: The Republican Print, 1885-86.

Murphy, Thomas. *Jubilee History. Commemorative of the Fiftieth Anniversary of the Creation of Lackawanna County, Pennsylvania.* Topeka, KS: Historical Publishing Co., 1928.

Nieroda, Joseph. "High School is Advanced Into History." *Sunday Times* (June 20, 1982).

Polk's City Directory. Boston, MA: Polk Publishing. Years include 1907-1991.

The Public School of the City of Scranton Pennsylvania. Scranton: The Republican Print, 1895.

Register and Directory of the Public Schools and Teachers. Scranton, 1925-26.

Scranton Directory, 1886. New York: Wanton S. Webb, 1886.

"Scranton in the Past: 20 Years Ago, Sept. 2, 1943," no author cited. *Scranton Times* (September 2, 1963).

Sobers, William. "New Campus a Moving Experience for Lackawanna Junior College." *Scranton Times* (August 9, 1982).

Taylor's Scranton City Directory. Scranton: Taylor Publishing, 1898.

Untitled article, no author cited. *Scrantonian* (June 14, 1970). Article discussing Scranton's historic school buildings. Miscellaneous files of the Lackawanna County Historical Society.

Walsh, Jack. "It's Moving Time for College." *Scranton Times* (August 3, 1982).

United States Department of the Interior
National Park Service

**National Register of Historic Places
Continuation Sheet**

Roger Williams Public School No. 10, Lackawanna County, Pennsylvania

Section number 10 Page 1

VERBAL BOUNDARY DESCRIPTION

Beginning at a point marking the intersection of the southerly right of way of Beech Street with the easterly right of way of Prospect Street; said point marking the northerly corner of lot #1 in Block 32 on map of the town plot of the City of Scranton as recorded in Lackawanna Co. m.b. 8 pg. 48; Thence along said southerly right of way of Beech Street S 45 degrees 00' E 140.00' to the intersection of the southerly right of way of said Beech Street with the westerly right of way of Donnelly Court; Thence along the right of way of said Donnelly Court S 45 degrees 00' W 290.00' to a common corner of lots 7 & 8 in said Block 32, said point marking a corner of lands now or formerly of Frank & Margaret Drazda; Thence along line of said Drazda and along the division line between lots 7 & 8 in block 32 N 45 degrees 00' W 140.00' to a point along the aforementioned easterly right of way of Prospect Street; Thence along the right of way of said Prospect Street N 45 degrees 00' E 290.00' to the place of beginning.

Containing 40,600 sq. ft. and being all of lots 1 through 7 in block 32 on the Town Plot of Scranton and as shown on drawing D-4-95 by John R. Hennemuth Assoc. Inc.

BOUNDARY JUSTIFICATION

The identified boundary is the historic property line of the nominated property and contains all related buildings and grounds.

**United States Department of the Interior
National Park Service**

**National Register of Historic Places
Continuation Sheet**

Section number _____ Page _____

SUPPLEMENTARY LISTING RECORD

NRIS Reference Number: 97000520 Date Listed: 6/13/97

Roger Williams Public School No. 10 Lackawana PA
Property Name: County: State:

Multiple Name

This property is listed in the National Register of Historic Places in accordance with the attached nomination documentation subject to the following exceptions, exclusions, or amendments, notwithstanding the National Park Service certification included in the nomination documentation.

Patrick Andrews
Signature of the Keeper

6/13/97
Date of Action

=====
Amended Items in Nomination:

On the nomination form the school addition is mistakenly counted as a separate building. The resource count in Section 5 of the form is amended to show that the nominated property consists of one contributing building.

DISTRIBUTION:

National Register property file
Nominating Authority (without nomination attachment)

UNITED STATES DEPARTMENT OF THE INTERIOR
NATIONAL PARK SERVICE

NATIONAL REGISTER OF HISTORIC PLACES
EVALUATION/RETURN SHEET

REQUESTED ACTION: NOMINATION

PROPERTY NAME: Williams, Roger, Public School No. 10

MULTIPLE NAME:

STATE & COUNTY: PENNSYLVANIA, Lackawanna

DATE RECEIVED: 4/30/97 DATE OF PENDING LIST: 5/13/97
DATE OF 16TH DAY: 5/29/97 DATE OF 45TH DAY: 6/14/97
DATE OF WEEKLY LIST:

REFERENCE NUMBER: 97000520

NOMINATOR: STATE

REASONS FOR REVIEW:

APPEAL: N DATA PROBLEM: N LANDSCAPE: N LESS THAN 50 YEARS: N
OTHER: N PDIL: N PERIOD: N PROGRAM UNAPPROVED: N
REQUEST: N SAMPLE: N SLR DRAFT: Y NATIONAL: N

COMMENT WAIVER: N

ACCEPT RETURN REJECT _____ DATE

ABSTRACT/SUMMARY COMMENTS:

Historically and architecturally significant late 19th century public school building. Although there is a large 1960's addition, it is sufficiently separated from the original building so it does not destroy the integrity of the 1890's school.

RECOM./CRITERIA accept A&C

REVIEWER Peteuk Andrus DISCIPLINE Historian

TELEPHONE _____ DATE 6/13/97

DOCUMENTATION see attached comments Y/N see attached SLR Y/N
456

LACKAWANNA JUNIOR COLLEGE



Roger Williams Public School No. 10
Lockawanna Co., PA

Timothy Noble

March 1994

Noble Preservation Services, Inc.

Looking SW at N (main) elevations of original building + addition

Photo # 1 of 20



Roger-Williams Public School No. 10
Lackawanna Co, PA

Timothy Noble

March 1996

Noble Preservation Services, Inc.

Detail view of main entrance on N elevation

Photo # 2 of 20



Roger Williams Public School No. 10
Lackawanna Co, PA

Timothy Noble

March 1996

Noble Preservation Services, Inc.

Looking S at E elevation of original building + adjoining
addition

Photo # 3 of 20



Roger Williams Public School No. 10
Lackawanna Co, PA

Timothy Noble

March 1996

Noble Preservation Services, Inc.

Looking N at E elevation of original building

Photo # 4 of 20



Roger Williams Public School No. 10
Lackawanna Co, PA

Timothy Noble

March 1996

Noble Preservation Services, Inc.

Looking SE at W elevation of original building +
addition

Photo # 5 of 20



Roger Williams Public School No. 10
Lackawanna Co., PA

Timothy Noble

March 1996

Noble Preservation Services, Inc.

Looking NE at W and S elevations of original building

Photo # 6 of 20



LACAPAWA JUNIOR COL

Roger Williams Public School No. 10
Lackawanna Co, PA

Timothy Noble

March 1996

Noble Preservation Services, Inc.

Looking NE at W elevation of original building + addition

Photo # 7 of 20



Roger Williams Public School No. 10

Lackawanna Co., PA

Timothy Noble

March 1996

Noble Preservation Services, Inc.

Looking E at joining of original building + addition

Photo # 8 of 20



Roger Williams Public School No.10

Lackawanna Co, PA

Timothy Noble

March 1996

Noble Preservation Services, Inc.

Looking NW at S+E elevations of addition

Photo #9 of 20



Roger Williams Public School No. 10

Lackawanna Co, PA

Timothy Noble

March 1996

Noble Preservation Services, Inc.

Looking at stair from 2nd to 3rd floor in SE corner of
original building

Photo # 10 of 20



Roger Williams Public School No. 10

Lackawanna Co, PA

Timothy Noble

March 1996

Noble Preservation Services, Inc.

Looking at stair at 5th floor in SE corner of original
building

Photo # 11 of 20



EXIT

Roger Williams Public School No. 10
Lackawanna Co, PA

Timothy Noble

March 1996

Noble Preservation Services, Inc.

Looking N at N stair in addition from ground to 1st floor

Photo # 12 of 20

Roger Williams Public School No. 10

Lackawanna Co, PA

Timothy Noble

March 1996

Noble Preservation Services, Inc.

Looking at corridor detail in 2nd floor of original
building

Photo # 13 of 20



Roger Williams Public School No. 10

Lackawanna Co, PA

Timothy Noble

March 1996

Noble Preservation Services, Inc.

Looking S in 1st floor corridor in addition

Photo #14 of 20



Roger Williams Public School No. 10

Lackawanna Co, PA

Timothy Noble

March 1996

Noble Preservation Services, Inc.

Looking S in 2nd floor corridor in ablation

Photo # 15 of 20

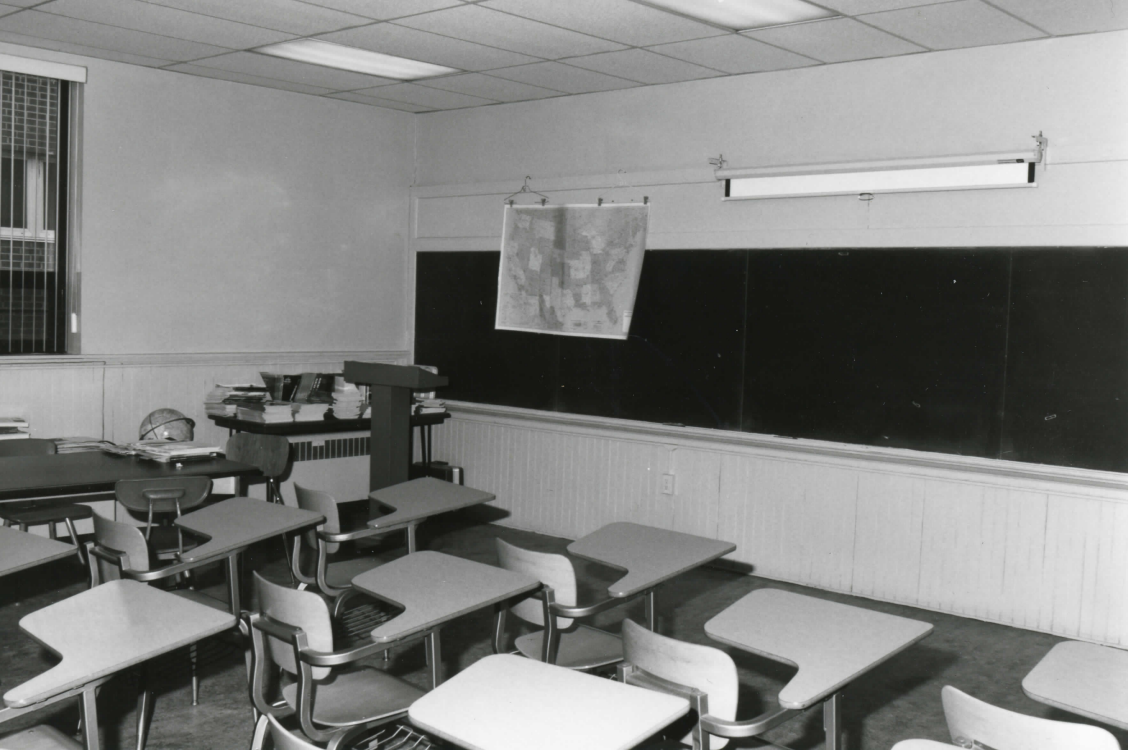

Roger Williams Public School No. 10

Lackawanna Co, PA

Timothy Noble

March 1996

Noble Preservation Services, Inc.

Looking SE in 2nd floor classroom in original building

Photo # 16 of 20

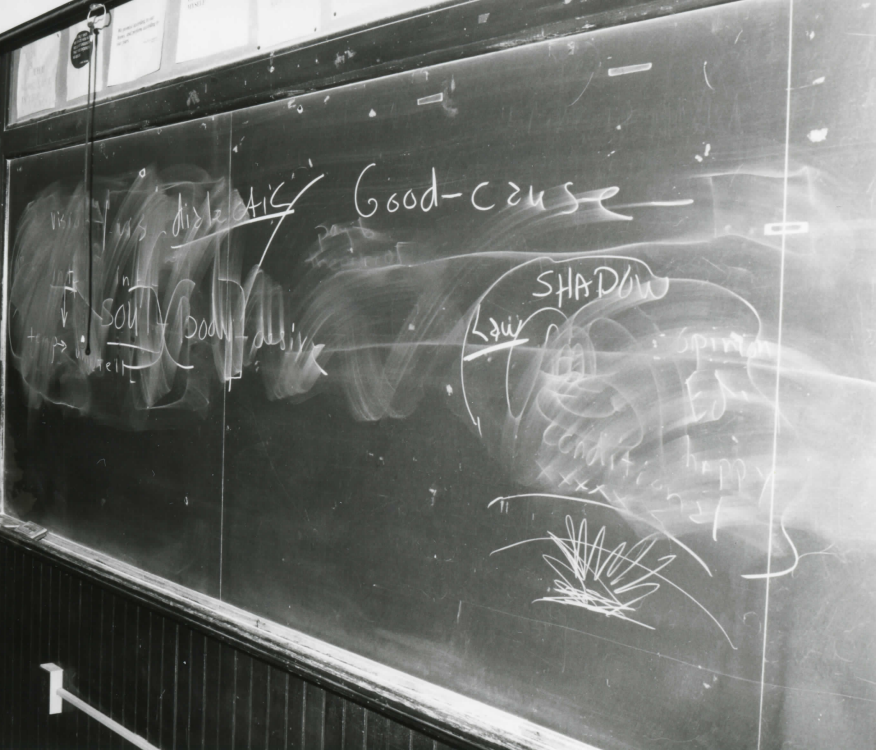

Roger Williams Public School No. 10
Lackawanna Co, PA

Timothy Noble

March 1996

Noble Preservation Services, Inc.

Looking NW in 2nd floor classroom in original building

Photo # 17 of 20

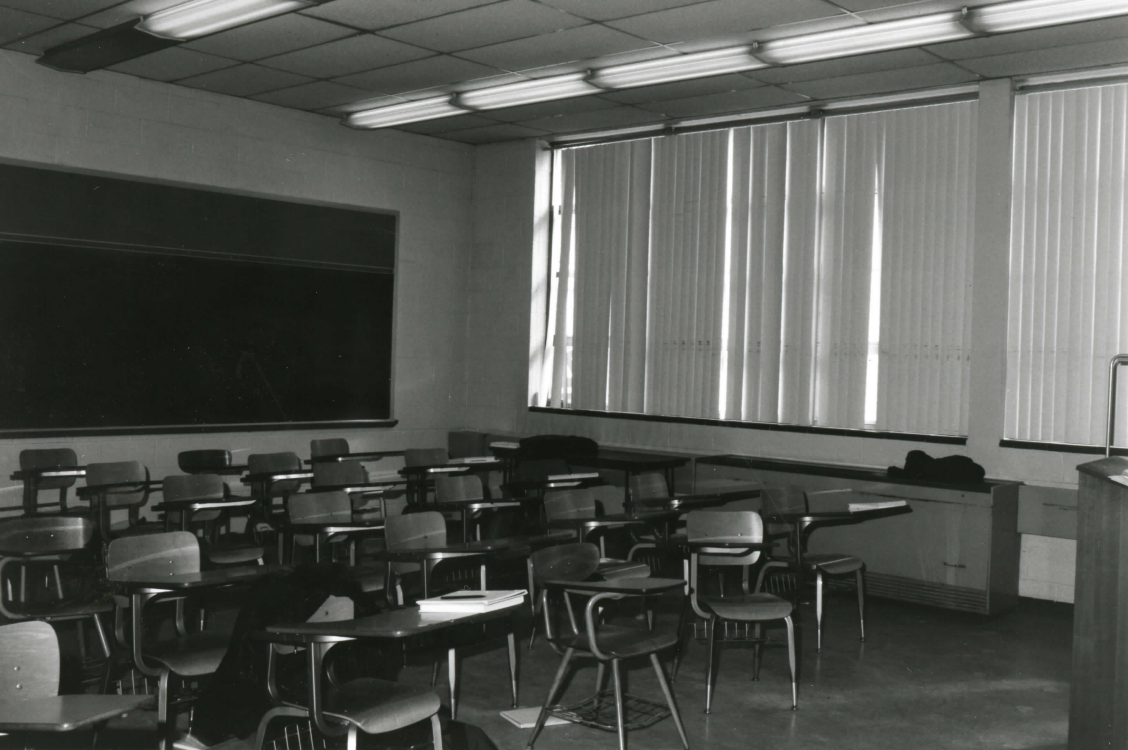

Roger Williams Public School No. 10
Lackawanna Co, PA

Timothy Noble

March 1996

Noble Preservation Services, Inc.

Looking NE in 1st floor classroom in addition

Photo # 18 of 20



Roger Williams Public School No. 10
Lackawanna Co, PA

Timothy Noble

March 1996

Noble Preservation Services, Inc.

Looking SW in 1st floor gymnasium in addition

Photo # 19 of 20



Roger Williams Public School No. 10
Lackawanna Co, PA

Timothy Noble

March 1996

Noble Preservation Services, Inc.

Looking SW in 2nd floor auditorium in addition

Photo # 20 of 20

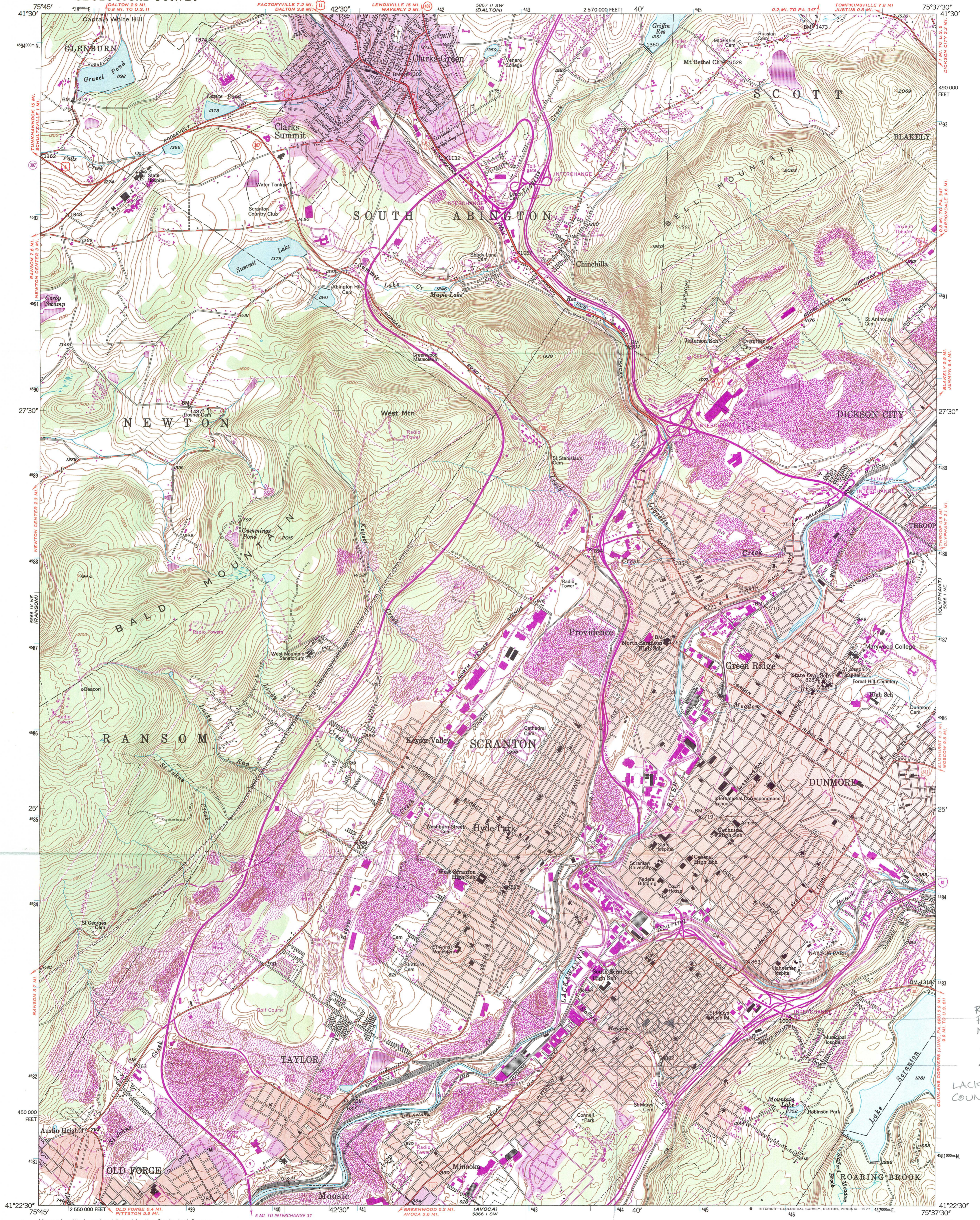

Mapped, edited, and published by the Geological Survey
Control by USGS and USC&GS
Topography by photogrammetric methods from aerial photographs
taken 1942. Field checked 1947
Polyconic projection, 1927 North American datum
10,000-foot grid based on Pennsylvania coordinate system, north zone
1000-meter Universal Transverse Mercator grid ticks, zone 18,
shown in blue
Red tint indicates areas in which only landmark buildings are shown
Purple tint indicates extension of urban areas
Revisions shown in purple compiled in cooperation with
State of Pennsylvania agencies, from aerial photographs
taken 1969 and 1976. This information not field checked

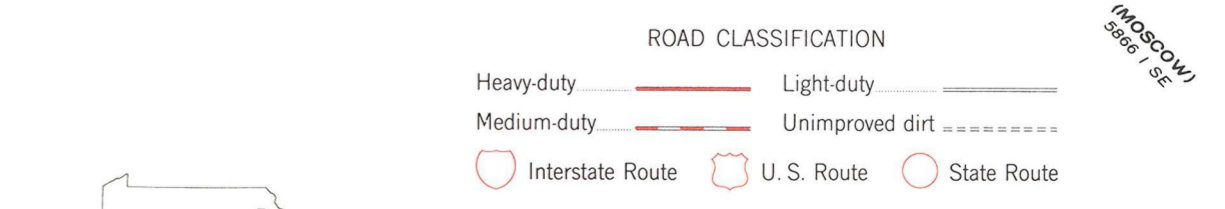
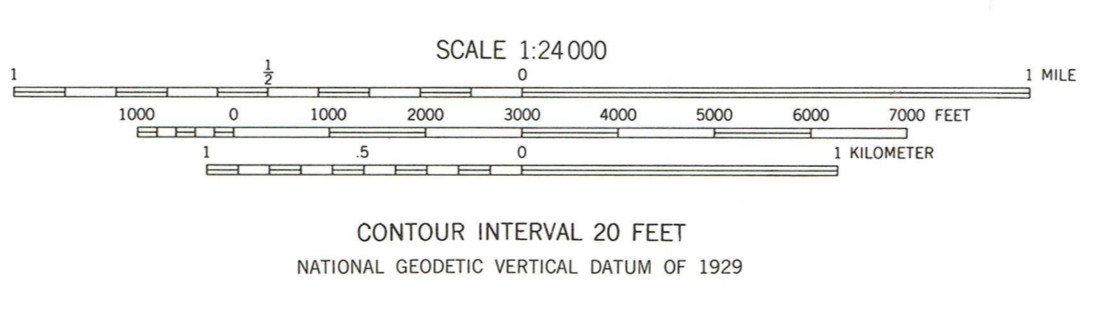
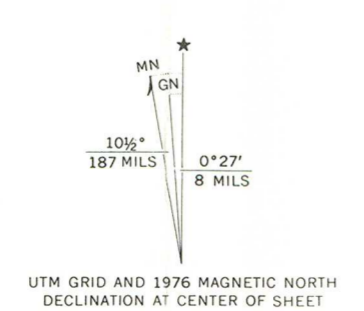

SCRANTON, PA.
N41225-W7537.5/7.5

THIS MAP COMPLIES WITH NATIONAL MAP ACCURACY STANDARDS
FOR SALE BY U.S. GEOLOGICAL SURVEY, RESTON, VIRGINIA 22092
A FOLDER DESCRIBING TOPOGRAPHIC MAPS AND SYMBOLS IS AVAILABLE ON REQUEST

1947
PHOTOREVISED 1969 AND 1976
AMS 5866 1 NW-SERIES V831

Roger Williams
Public School
No 10
444340
4582500
LACKAWANNA
COUNTY, PA