

United States Department of the Interior
National Park Service

National Register of Historic Places
Registration Form

1080

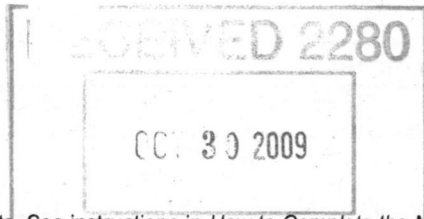

This form is for use in nominating or requesting determinations for individual properties and districts. See instructions in *How to Complete the National Register of Historic Places Registration Form* (National Register Bulletin 16A). Complete each item by marking "x" in the appropriate box or by entering the information requested. If an item does not apply to the property being documented, enter "N/A" for "not applicable." For functions, architectural classification, materials, and areas of significance, enter only categories and subcategories from the instructions. Place additional entries and narrative items on continuation sheets (NPS Form 10-900a). Use a typewriter, word processor, or computer, to complete all items.

1. Name of Property

historic name Stage Coach Inn

other name/site number Royal Johnson House

2. Location

street & number 2548 Clarks Corners Road not for publication

city or town Lapeer vicinity _____

state New York code NY county Cortland code 023 zip code 13803

3. State/Federal Agency Certification

As the designated authority under the National Historic Preservation Act, as amended, I hereby certify that this nomination request for determination of eligibility meets the documentation standards for registering properties in the National Register of Historic Places and meets the procedural and professional requirements set forth in 36 CFR Part 60. In my opinion, the property meets does not meet the National Register criteria. I recommend that this property be considered significant nationally statewide locally. (See continuation sheet for additional comments.)
Ruth A. Purpant / DSHPD 10/20/09
Signature of certifying official/Title Date
New York State Office of Parks, Recreation and Historic Preservation
State or Federal agency and bureau

In my opinion, the property meets does not meet the National Register criteria. (See continuation sheet for additional comments.)

Signature of certifying official/Title Date

State or Federal agency and bureau

4. National Park Service Certification

- I hereby certify that the property is:
 entered in the National Register.
 See continuation sheet.
- determined eligible for the National Register
 See continuation sheet.
- determined not eligible for the National Register.
- removed from the National Register.
- other, (explain:) _____

for
Signature of the Keeper Edson W. Beall Date of Action 12-11-09

5. Classification

Ownership of Property
(check as many boxes as apply)

- public-local
- private
- public-State
- public-Federal

Category of Property
(check only one box)

- district
- building(s)
- site
- structure
- object

Number of Resources within Property
(Do not include previously listed resources in the count.)

Contributing	Noncontributing	
1	0	buildings
		sites
		structures
		objects
1	0	Total

Name of related multiple property listing
(Enter "N/A" if property is not part of a multiple property listing.)

N/A

Number of contributing resources previously listed in the National Register

0

6. Function or Use

Historic Function
(Enter categories from instructions)

HOTEL: Inn

DOMESTIC: single dwelling (for owner)

POST OFFICE: Post office

Current Function
(Enter categories from instructions)

DOMESTIC: Single dwelling (vacant)

7. Description

Architectural Classification
(Enter categories from instructions)

MID-19TH CENTURY: Greek Revival

Materials
(Enter categories from instructions)

foundation stone

walls clapboard with cement asbestos siding added

roof asphalt shingle

other _____

Narrative Description

(Describe the historic and current condition of the property on one or more continuation sheets.)

Stage Coach Inn (Royal Johnson House)
Lapeer, Cortland County, New York

NATIONAL REGISTER OF HISTORIC PLACES CONTINUATION SHEET

Section number 7 Page 1

DESCRIPTION

The Stage Coach Inn, also known as the Royal Johnson House, was built in the first quarter of the nineteenth century in what was then the town of Virgil in Cortland County, southeast of New York's Finger Lakes Region. After 1845, the town of Virgil was subdivided into smaller towns and this property became part of the new town of Lapeer.

The building is situated on what was originally called Stage Road 77. Surrounding the building are some older maple and evergreen trees and scattered homes, some of which are old, some newer. The building once functioned as a post office and was located at a major crossroads in the town that was labeled "Lapeer P.O." on the county atlas of 1876.

The two-story house is set on a stone foundation and is rectangular in plan with a five-bay center-entrance on the main elevation. The entryway is a full-blown Greek Revival style entrance, with pilasters, a full entablature and a two-paneled door with sidelights. The shallow-pitched gable roof, with the ridge parallel to the front wall, rests on a full entablature and broad pilasters at the corners, matching in proportion the trim of the front entryway.

The sides of the main block are characterized by an unusually wide roof pitch, making for wider side elevations. Four windows are present in each of the side elevations, and on the east side, a door that matches the front door with the exception of its width, is present on the first floor between the two middle windows of the elevation. The heavy entablature and pilasters seem to be squeezed into the narrow space between the windows, but unlike the west side, which has four evenly-spaced window openings, the two center windows of the west elevation are spaced to accommodate the door. All windows on the main block contain one-over-one sash and this condition is apparent in a historic photograph of the building that dates from around 1900. Only in the attic on both gable ends are what appear to be original windows—six large panes set within frames of smaller panes in a large composition arranged in two vertical sections by three horizontal sections.

The rear of the house includes a later one-story wing that was added in two sections. The addition closest to the main block contains usable rooms and once had an open porch, enclosed at some time after about 1900 when a historic photograph of the house was taken.

The main block of the house was sided with a rigid modern siding but the original clapboards are assumed to be present underneath the siding. Another area has vinyl siding, but the owners hope to be able to remove later sidings to restore the building to its original appearance. Roofs of all wings of the building are covered in asphalt shingle.

On the interior, the floor plan retains many of its original spaces. When entering in the main door, which, even in the c.1900 photograph did not have a set of steps leading up to the door, there is a long narrow hall that runs from the front to the back of the main block. On either side of that hall, which also contains the staircase, are front parlors, a second parlor on the east side, and behind the west parlor, a

Stage Coach Inn (Royal Johnson House)
Lapeer, Cortland County, New York

**NATIONAL REGISTER OF HISTORIC PLACES
CONTINUATION SHEET**

Section number 7 Page 2

smaller room and a bathroom entered from either the small room or the rear wing. The bathroom was most likely installed sometime in the twentieth century.

Beneath the staircase leading to the second floor is one leading to the cellar. The first wing contains a large room immediately adjacent to the main block of the house probably once used as a living or dining room, and the rest of the wing is taken up by a kitchen, den, and another miscellaneous room. Across the main axis of this wing is a formerly open porch, now enclosed. At the rear of this wing is a second wing that functioned as a woodshed, but is now a garage.

The interior of the house is very modestly decorated. In the front hall, a staircase ascends on the west wall of the room behind the door to the west parlor. The balustrade is very simple and the baseboard is simple 1x6 with a round bead on top. Door and window trim in the parlors consists of a modest profile on the otherwise flat casing. There are no fireplace mantels present and the chimneys pictured in the historic photograph have been removed.

In the corners of the rooms in the main block, the heavy timber posts are visible, although covered with plaster and baseboard. Ceilings are flat with no decorative plaster. In the rear wing, there is a room called the men's den which has glass-front cabinetry and a ceiling and walls with visible furring strips marking the joints is the modern ceiling material. The former open porch has knotty pine paneling.

On the second floor of the main block, there is a room across the front that is a ballroom, dating from the period when the property was a stagecoach stop. Projecting into the rooms on either side of the center window and at the corners are enclosures of the heavy timber framing that characterizes the main house. At one of the projecting framing members, there are marks in the ceiling and floor that suggest the room was once enlarged from this point to the exterior east wall. This clue may also be suggested in the different color of the woodwork in this third of the room. There is a fiddlers' bench in the ballroom. Behind the ballroom are east and west bedrooms as well as a hallway at the top of the stairs. All woodwork on this floor matches that of the first and all ceilings are flat plaster with no decorative finishes.

8. Significance

Applicable National Register Criteria

(Mark "x" in one or more boxes for the criteria qualifying the property for National Register listing.)

- A** Property is associated with events that have made a significant contribution to the broad patterns of our history.
- B** Property is associated with the lives of persons significant in our past.
- C** Property embodies the distinctive characteristics of a type, period, or method of construction or represents the work of a master, or possesses high artistic values, or represents a significant and distinguishable entity whose components lack individual distinction.
- D** Property has yielded, or is likely to yield, information important in prehistory or history.

Criteria Considerations

(Mark "x" in all the boxes that apply.)

Property is:

- A** owned by a religious institution or used for religious purposes.
- B** removed from its original location.
- C** a birthplace or grave.
- D** a cemetery.
- E** a reconstructed building, object, or structure.
- F** a commemorative property.
- G** less than 50 years of age or achieved significance within the past 50 years.

Narrative Statement of Significance

(Explain the significance of the property on one or more continuation sheets.)

Areas of Significance

(enter categories from instructions)

ARCHITECTURE

COMMERCE

Period of Significance

c. 1830-c.1920

Significant Dates

c. 1830

Significant Persons

(Complete if Criterion B is marked above)

Cultural Affiliation

Architect/Builder

N/A

9. Major Bibliographical References

Bibliography

(Cite the books, articles, and other sources used in preparing this form on one or more continuation sheets.)

Previous documentation on file (NPS):

- preliminary determination of individual listing (36 CFR 67) has been requested
- previously listed in the National Register
- previously determined eligible by the National Register
- designated a National Historic Landmark
- recorded by Historic American Buildings Survey # _____
- recorded by Historic American Engineering Record # _____

Primary location of additional data:

- State Historic Preservation Office
- Other State agency
- Federal agency
- Local government
- University
- Other Name of repository: _____

Stage Coach Inn (Royal Johnson House)
Name of Property

Marathon, Cortland County, New York
County and State

10. Geographical Data

Acreage of Property 1 acre

UTM References

(Place additional boundaries of the property on a continuation sheet.)

1 18 409596 4699433
Zone Easting Northing

2 18
Zone Easting Northing

3 18
Zone Easting Northing

4 18
Zone Easting Northing

See continuation sheet

Verbal Boundary Description

(Describe the boundaries of the property on a continuation sheet.)

Boundary Justification

(Explain why the boundaries were selected on a continuation sheet.)

11. Form Prepared By

name/title Anthony Opalka
organization NYS Historic Preservation Office date October 2009
street & number PO Box 189 telephone 518-237-8643
city or town Waterford state NY zip code 12188

Additional Documentation

Submit the following items with the completed form:

Continuation Sheets

Maps

- A **USGS map** (7.5 or 15 minute series) indicating the property's location.
- A **Sketch map** for historic districts and properties having large acreage or numerous resources.

Photographs

Representative black and white photographs of the property.

Additional items

(Check with the SHPO or FPO for any additional items)

Property Owner

(Complete this item at the request of SHPO or FPO.)

name/title _____
street & number _____ telephone _____
city or town _____ state _____ zip code _____

Paperwork Reduction Act Statement: This information is being collected for applications to the National Register of Historic Places to nominate properties for listing or determine eligibility for listing, to list properties, and to amend existing listings. Response to this request is required to obtain a benefit in accordance with the National Historic Preservation Act, as amended (16 U.S.C. 470 *et seq.*).

Estimated Burden Statement: Public reporting burden for this form is estimated to average 18.1 hours per response including time for reviewing instructions, gathering and maintaining data, and completing and reviewing the form. Direct comments regarding this burden estimate or any aspect of this form to the Chief, Administrative Services Division, National Park Service, P.O. Box 37127, Washington, DC 20013-7127; and the Office of Management and Budget, Paperwork Reductions Projects (1024-0018), Washington, DC 20503.

Stage Coach Inn (Royal Johnson House)
Lapeer, Cortland County, New York

**NATIONAL REGISTER OF HISTORIC PLACES
CONTINUATION SHEET**

Section number 8 Page 1

STATEMENT OF SIGNIFICANCE

The Stagecoach Inn, also known as the Royal Johnson House, is significant under National Register Criterion A as what is thought to be the earliest building house constructed by European-Americans in the rural town of Lapeer in Cortland County, in Central New York. Believed to have been constructed in the 1830s, judging from some of its architectural features, in its early years it was a community center of the small hamlet later known as Lapeer Post Office since it served as a home, a hostelry for stage coach travelers, a post office, as well as a dance hall. It remained in the Johnson family from the time of its construction in the early years of the nineteenth century until the opening years of the twenty-first century and its second-floor ballroom is intact to this day.

In addition, the property is significant under Criterion C as an intact example of the frontier residence of a prominent citizen within the small crossroads community that exhibits characteristics of the Greek Revival style that were popular when this region underwent its first wave of development in the new State of New York.

Prior to the American Revolution, this territory was the land of the Iroquois tribe, the confederation of five (later six) nations, all of whom but the Oneidas sided with the British against the American colonists. The lands of the Iroquois were confiscated at the close of the war and since the new state had insufficient funds to pay Revolutionary War veterans, a system was devised wherein soldiers would be paid in land in the center of the state as a way to encourage settlement west of the Hudson River Valley where most settlement was already concentrated. The state divided these 1.7 million acres of Iroquois land into plots of 600 acres for payment in an area that came to be known as the Military Tract. The land was divided into 28 towns, 25 of which were given names of ancient Roman and Greek literary and military figures. This part of what was later Cortland County was named for Virgil, ancient Rome's greatest poet and author of the *Aeneid*.

At the time the Royal Johnson House was constructed, it was within the town of Virgil, but in 1845, in a movement in keeping with other parts of the Military Tract, Virgil was subdivided into smaller towns, and this town became known as Lapeer. The town was named by its most prominent citizen Hon. Dan C. Squires, who became its first supervisor. Squires said that although Lapeer was the newest of the towns of the county, it equal to all others in the county, and combined the French article "la" with the English word "peer" to come up with this town's unique name.

To this day Lapeer is mainly a rural town with no large town centers. Throughout its history, Lapeer was an agricultural town, producing potatoes, apples, and dairy products, including cheese. There were also sawmills, wagon shops, grist, feed, and cider mills, boot and shoemakers, and grocery and hardware stores. The building served as a stagecoach stop between the nearby localities of Marathon and Harford, both in Cortland County, along what was originally called Stage Road 77.

Royal Johnson, builder of this house, was the supervisor of the town for several non-consecutive

Stage Coach Inn (Royal Johnson House)
Lapeer, Cortland County, New York

**NATIONAL REGISTER OF HISTORIC PLACES
CONTINUATION SHEET**

Section number 8 Page 2

terms in the second half of the nineteenth century, and was also named postmaster. He maintained an inn at this building, which became the social center of the rural town, where many musical gatherings were held. The fiddlers' bench remains in the ballroom and the great grandfather of the present owner was the "town fiddler" who played his instrument many times in this location. The Stage Coach Inn remained prominent in the town's social life into the 1920s.

Architecturally, the house exhibits characteristics of the Greek Revival style mainly in its entryway, a set of wide pilasters supporting a heavy entablature, and matching two-story pilasters marking the corners of the main block. It is unusual in the depth of the main block where four bays are present on the west elevation and the east elevation includes a side door, squeezed between two windows of the four bays of the first story. It appears to be somewhat larger than other buildings of the period in this part of the state, and this may be due in part to the fact that it also served as a post office and inn. There are later additions attached to the rear of the building which are present in a c.1900 photograph of the building. The open porch in that photograph has since been enclosed.

The interior of the building exhibits the most modest of decorative features, with plain window architraves and only slightly decorated door architraves and baseboards.

The property is significant as perhaps the earliest European-American building in the town and one that served as the social center of this rural community. The owners desire National Register listing to commemorate the importance of the Royal Johnson House in Lapeer.

Stage Coach Inn (Royal Johnson House)
Lapeer, Cortland County, New York

**NATIONAL REGISTER OF HISTORIC PLACES
CONTINUATION SHEET**

Section number 9 Page 1

BIBLIOGRAPHY

Smith, H.P., editor: History of Cortland County : with illustrations and biographical sketches of some of its prominent men and pioneers, Syracuse, N.Y.: D. Mason, 1885.

Looking Through the Years...with Pride, Marathon Bicentennial, May 14 and 15, 1976, by Vera Johnson, Town Historian.

Cortland County Deeds, Census Records, throughout the nineteenth century.

Stage Coach Inn (Royal Johnson House)
Lapeer, Cortland County, New York

**NATIONAL REGISTER OF HISTORIC PLACES
CONTINUATION SHEET**

Section number 10 Page 1

VERBAL BOUNDARY DESCRIPTION

The property boundary is outlined on the attached map.

BOUNDARY JUSTIFICATION

The nominated property includes the boundary that is currently associated with the Stage Coach Inn (Royal Johnson House).

Stage Coach Inn (Royal Johnson House)
Lapeer, Cortland County, New York

**NATIONAL REGISTER OF HISTORIC PLACES
CONTINUATION SHEET**

Section number 11 Page 1

Research Information provided by

Grace Stone, Property owner
c/o 2548 Clarks Corners Road
Marathon, NY 13803

Stage Coach Inn (Royal Johnson House)
Lapeer, Cortland County, New York

NATIONAL REGISTER OF HISTORIC PLACES
CONTINUATION SHEET

Section number 12 Page 1



1854 Cotillon Invitation
Royal Johnson House

Stage Coach Inn (Royal Johnson House)
Lapeer, Cortland County, New York

**NATIONAL REGISTER OF HISTORIC PLACES
CONTINUATION SHEET**

Photographs

Photographs

Photographer: Grace Stone, Property owner
2548 Clarks Corners Road
Marathon, NY 13803

Date: November 2008

Tiff Files: CD-R of .tiff files on file at
National Park Service
Washington, DC, and

Historic Preservation Field Services Bureau
Pebbles Island
PO Box 189
Waterford, NY 12188-0189

1. Exterior, Façade, photographer facing south
2. Exterior, east side, photographer facing west
3. Exterior, west side, photographer facing east
4. Interior, first floor east parlor, photographer facing northeast
5. Interior, stairhall, photographer facing south
6. Interior, first floor second parlor, photographer facing south
7. Interior, first room in south wing, photographer facing west
8. Interior, kitchen in south wing, photographer south
9. Interior, west front room, photographer facing northwest
10. Interior, second floor bedroom, photographer facing south
11. Interior, second floor ballroom, photographer facing west
12. Interior, second floor ballroom, photographer facing west
13. Interior, second floor ballroom, photographer facing east
14. Interior, second floor stairhall, photographer facing north

Stage Coach Inn (Royal Johnson House)
Lapeer, Cortland County, New York

**NATIONAL REGISTER OF HISTORIC PLACES
CONTINUATION SHEET**

Section number Page 1



Stage Coach Inn-Royal Johnson House, c. 1890s

UNITED STATES DEPARTMENT OF THE INTERIOR
NATIONAL PARK SERVICE

NATIONAL REGISTER OF HISTORIC PLACES
EVALUATION/RETURN SHEET

REQUESTED ACTION: NOMINATION

PROPERTY Stage Coach Inn
NAME:

MULTIPLE
NAME:

STATE & COUNTY: NEW YORK, Cortland

DATE RECEIVED: 10/30/09 DATE OF PENDING LIST: 11/18/09
DATE OF 16TH DAY: 12/03/09 DATE OF 45TH DAY: 12/13/09
DATE OF WEEKLY LIST:

REFERENCE NUMBER: 09001080

REASONS FOR REVIEW:

APPEAL: N DATA PROBLEM: N LANDSCAPE: N LESS THAN 50 YEARS: N
OTHER: N PDIL: N PERIOD: N PROGRAM UNAPPROVED: N
REQUEST: N SAMPLE: N SLR DRAFT: N NATIONAL: N

COMMENT WAIVER: N

ACCEPT RETURN REJECT 12-11-09 DATE

ABSTRACT/SUMMARY COMMENTS:

**Entered in
The National Register
of
Historic Places**

RECOM./CRITERIA _____

REVIEWER _____ DISCIPLINE _____

TELEPHONE _____ DATE _____

DOCUMENTATION see attached comments Y/N see attached SLR Y/N

If a nomination is returned to the nominating authority, the nomination is no longer under consideration by the NPS.



STAGE COACH INN (ROYAL JOHNSON HOUSE)
~~MANHATTAN~~, CAPEER, CORTLAND CO. NY.

PHOTO #1



STAGE COACH INN (ROYAL JOHNSON HOUSE)
LAPEER, CORTLAND CO. N.Y.

PHOTO #2



STAGE COACH INN (ROYAL JOHNSON HOUSE)
LAPEER, CORTLAND CO. N.Y.

PHOTO #3



STAGE COACH INN (ROYAL JOHNSON HOUSE)
LAPEER, CORTLAND CO. N.Y.

PHOTO #4



STAGE COACH INN (ROYAL JOHNSON TO USE)
LAPEER, CORTLAND CO. N.Y.

PHOTO #5



STAGE COACH INN (ROYAL JOHNSON HOUSE)
LAPEER, CORTLAND CO. NY.

PHOTO #6



STAGE COACH INN (ROYAL JOHNSON HOUSE)
LAPEER, CORTLAND CO. N.Y.

PHOTO # 7



STAGE COACH INN (ROYAL JOHNSON HOUSE)
LAPEER, CORTLAND CO. NY.

PHOTO #8



STAGE COACH INN (ROYAL JOHNSON HOUSE)
LAPEER, CORTLAND CO. N.Y.

PHOTO #9



STAGE COACH INN (ROYAL JOHNSON HOUSE)
LAPEER, CORTLAND CO. N.Y.

PHOTO #10



STAGE COACH INN (ROYAL JOHNSON HOUSE)
LAPEER, CORTLAND CO. N.Y.

PHOTO #11



STAGE COACH INN (ROYAL JOHNSON HOUSE)
LAPEER, CORTLAND CO. N.Y.

PHOTO #12



EPSON

STAGE COACH INN (ROYAL JOHNSON HOUSE)
LAPEER, CORTLAND CO. N.Y.

EPSON

PHOTO #13

EPSON



STAGE COACH INN (ROYAL JOHNSON HOUSE)
LAPEER, CORTLAND CO. N.Y.

PHOTO #14



STABECOACH INN
(ROYAL JOHNSON
HOUSE)
LAPEER, CORTLAND
COUNTY, NEW YORK
MARATHON QUAD
ZONE 18

Produced by the U. S. Geological Survey
Control by USGS, NOS/NOAA and USCE
Topography from aerial photographs by multiplex methods
Aerial photographs taken 1944. Field checked 1955
Projection and 10,000-foot grid ticks: New York coordinate
system, central zone (transverse Mercator)
1000-meter Universal Transverse Mercator grid ticks, zone 18, shown in blue
1927 North American Datum (NAD 27)
North American Datum of 1983 (NAD 83) is shown by dashed corner ticks
The values of the shift between NAD 27 and NAD 83 for 7.5-minute
intersections are given in USGS Bulletin 1875
There may be private inholdings within the boundaries of
the National or State reservations shown on this map
Photinspected from 1992 source; no major culture or drainage
changes observed. Boundaries and names revised 1994

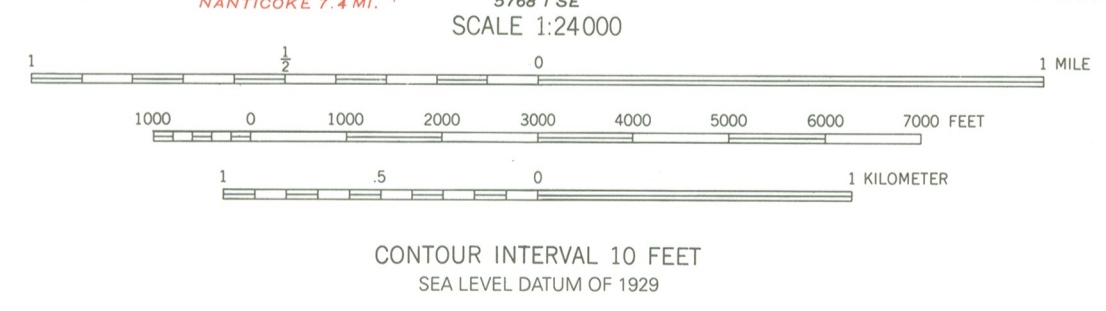
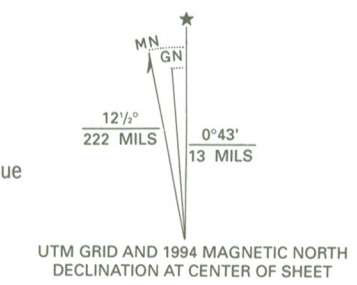

ROAD CLASSIFICATION

Primary highway, all weather, hard surface	Light-duty road, all weather, improved surface
Secondary highway, all weather, hard surface	Unimproved road, fair or poor weather

 Interstate Route
 U. S. Route
 State Route



MARATHON, N.Y.
42076-D1-TF-024
1950
PHOTOREVISED 1978
MINOR REVISION 1994
DMA 5768-1 NE - SERIES V821

THIS MAP COMPLIES WITH NATIONAL MAP ACCURACY STANDARDS
FOR SALE BY U. S. GEOLOGICAL SURVEY
DENVER, COLORADO 80225, OR RESTON, VIRGINIA 22092
A FOLDER DESCRIBING TOPOGRAPHIC MAPS AND SYMBOLS IS AVAILABLE ON REQUEST

Revisions shown in purple and woodland compiled
from aerial photographs taken 1976 and other sources
This information not field checked. Map edited 1978

March 9, 2009

NYS Office of Parks, Recreation and Historic Preservation
Historic Preservation Field Services Bureau
Peebles Island, P. O. Box 189
Waterford, New York 12188-0189

Attn: Ruth Pierpont

Re: Royal Johnson House
2548 Clarks Corners Road, Marathon, NY 13803
Cortland County

Dear Ms. Pierpont:

I was recently appointed the Historian for the Town of Lapeer and have been forwarded the information regarding the listing of the above-referenced property on the National and State Registers of Historic Places.

In searching through the files and records pertaining to the Johnson family of Lapeer, I discovered the following bits of information:

- Royal Johnson was born on March 13, 1803 and died on Nov. 23, 1879.
- His parents, Abner and Louisa Johnson, were some of the first pioneer inhabitants in the Town of Lapeer, settling in the area in 1811.
- According to notes I found, Royal built the only house in town erected for a tavern, which has been kept in its original form even down to the "fiddler's bench" located in the ballroom.
- The property was also used as a stage stop and post office for Lapeer.
- A journal listing the assessment roll for 1854 depicts the value of this property at \$1,150.00, with taxes in the amount of \$4.71.

Although I could not find any records indicating the actual construction date of the house, a logical assumption could be made that it was built between the years of 1823 and 1854 (1823-Royal Johnson was 20; 1854-the property value of \$1,150). Using this time span, the house would be estimated to be from 155 to 186 years old!

Based on the above noted information, I would enthusiastically support this property for listing on the National and State Registers of Historic Places.

Sincerely,

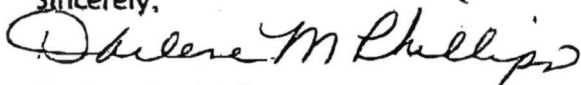

Darlene M. Phillips
Lapeer Town Historian
(607) 849-3037



**New York State Office of Parks,
Recreation and Historic Preservation**

Historic Preservation Field Services Bureau • Peebles Island, PO Box 189, Waterford, New York 12188-0189

518-237-8643

www.nysparks.com

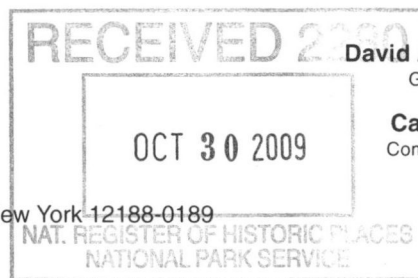

David A. Paterson
Governor

Carol Ash
Commissioner

October 22, 2009

Ms. Alexis Abernathy
National Park Service
National Register of Historic Places
1201 Eye St. NW
8th Floor
Washington, D.C. 20005

Re: Transmittal of National Register
Nominations

Dear Ms. Abernathy:

I am pleased to transmit five new National Register nominations to be considered for listing by the Keeper of the National Register as follows:

Stage Coach Inn, Lapeer, Cortland Co., NY

Chittenango Pottery, Chittenango, Madison Co., NY

Preston-Gaylord Cobblestone Farmhouse, Sodus, Wayne Co., NY (Cobblestone MPDF)

Jewish Center of Lake Huntington, Lake Huntington, Sullivan Co., NY

The Church-in-the-Gardens, Forest Hills, Queens Co., NY

Thank you for your assistance in processing these proposals. Please feel free to call on me at 518-237-8643 ext. 3258 if any questions arise.

Sincerely,

Mark L. Peckham
National Register
Program Coordinator

enclosures