

580

RECEIVED  
MAR 07 1990

United States Department of the Interior  
National Park Service

National Register of Historic Places  
Registration Form

DIVISION OF  
NATIONAL REGISTER PROGRAMS  
NATIONAL PARK SERVICE

This form is for use in nominating or requesting determinations of eligibility for individual properties or districts. See instructions in *Guidelines for Completing National Register Forms* (National Register Bulletin 16). Complete each item by marking "x" in the appropriate box or by entering the requested information. If an item does not apply to the property being documented, enter "N/A" for "not applicable." For functions, styles, materials, and areas of significance, enter only the categories and subcategories listed in the instructions. For additional space use continuation sheets (Form 10-900a). Type all entries.

1. Name of Property

historic name Longfellow, Henry Wadsworth, Monument

other names/site number \_\_\_\_\_

2. Location

street & number SE Corner of State and Congress Streets

not for publication

city, town Portland

vicinity

state Maine

code ME

county Cumberland

code 005

zip code 04101

3. Classification

Ownership of Property

- private
- public-local
- public-State
- public-Federal

Category of Property

- building(s)
- district
- site
- structure
- object

Number of Resources within Property

Contributing	Noncontributing
_____	_____ buildings
_____	_____ sites
_____	_____ structures
<u>1</u>	_____ objects
<u>1</u>	<u>0</u> Total

Name of related multiple property listing:

N/A

Number of contributing resources previously listed in the National Register 0

4. State/Federal Agency Certification

As the designated authority under the National Historic Preservation Act of 1966, as amended, I hereby certify that this  nomination  request for determination of eligibility meets the documentation standards for registering properties in the National Register of Historic Places and meets the procedural and professional requirements set forth in 36 CFR Part 60. In my opinion, the property  meets  does not meet the National Register criteria.  See continuation sheet.

Earl S. Peterson  
Signature of certifying official  
Maine Historic Preservation Commission  
State or Federal agency and bureau

2/27/90  
Date

In my opinion, the property  meets  does not meet the National Register criteria.  See continuation sheet.

\_\_\_\_\_  
Signature of commenting or other official  
\_\_\_\_\_  
State or Federal agency and bureau

\_\_\_\_\_  
Date

5. National Park Service Certification

I, hereby, certify that this property is:

- entered in the National Register.  See continuation sheet.
- determined eligible for the National Register.  See continuation sheet.
- determined not eligible for the National Register.
- removed from the National Register.
- other, (explain:)

Entered in the  
National Register

Delores Byers

4/5/90

\_\_\_\_\_  
Signature of the Keeper

\_\_\_\_\_  
Date of Action

**6. Function or Use**

Historic Functions (enter categories from instructions)

Recreation &amp; Culture

Current Functions (enter categories from instructions)

Recreation &amp; Culture

**7. Description**Architectural Classification  
(enter categories from instructions)

No Style

Materials (enter categories from instructions)

foundation N/A

walls N/A

roof N/A

other Granite Pedestal supporting  
a Bronze Sculpture

Describe present and historic physical appearance.

Located at Longfellow Square, the corner of State and Congress Streets in downtown Portland, this monument consists of a rectangular granite pedestal supporting the seated figure of Longfellow. The pedestal, which is approximately ten feet in height, is comprised of a two tier stepped plinth upon which is the centrally placed dado. This dado is ornamented with a molded base, two rectangular tablets, and a frieze embellished with anthemions and vines. The tablets feature eared upper corners, lower corners joined by a swag and an oval garland framing the single word LONGFELLOW. A broad cornice with multiple moldings lies below the stepped cap.

The bronze statue depicts the seated Longfellow much as he appeared late in life. Rising some seven feet above the pedestal, the figure is seated in a chair whose arms terminate with Lions' heads. Beneath the chair is a stack of books. Longfellow is clothed in an overcoat and a cape is draped across his lap and one shoulder. His right arm is propped on the chair back whereas his left hand holds a manuscript. The head is tilted so as to gaze upon passers by.

**8. Statement of Significance**

Certifying official has considered the significance of this property in relation to other properties:

nationally  statewide  locally

Applicable National Register Criteria  A  B  C  D

Criteria Considerations (Exceptions)  A  B  C  D  E  F  G

Areas of Significance (enter categories from instructions)

Art  
\_\_\_\_\_  
\_\_\_\_\_  
\_\_\_\_\_  
\_\_\_\_\_

Period of Significance

1888  
\_\_\_\_\_  
\_\_\_\_\_

Significant Dates

1888  
\_\_\_\_\_  
\_\_\_\_\_

Cultural Affiliation

N/A  
\_\_\_\_\_  
\_\_\_\_\_

Significant Person

N/A  
\_\_\_\_\_

Architect/Builder

Simmons, Franklin, Sculptor  
Fassett, Francis H., Architect

State significance of property, and justify criteria, criteria considerations, and areas and periods of significance noted above.

Conceived in 1882 and unveiled six year later, the monument to Henry Wadsworth Longfellow in Portland is one of the most significant pieces of public statuary in Maine. The bronze figure was created by sculptor Franklin Simmons, a native of Webster, Maine, and an artist who achieved national recognition. A rectangular granite pedestal designed by Portland architect Francis H. Fassett supports the seated image of Longfellow. This object is eligible for nomination to the Register under criterion C for its artistic significance.

Soon after Longfellow's death in 1882 the Longfellow Statue Association was formed in Portland to solicit funds for and select the design of a public monument honoring the poet in the city of his birth. Donations were subsequently received from throughout the United States and a number of foreign countries. In October of 1885 Franklin Simmons was selected as the artist. Francis Fassett's design for the pedestal was accepted in February, 1887.

The September 26, 1888, edition of the Eastern Argus (Portland) carried a brief article about the sculpture's arrival and its erection on the pedestal. It was formally unveiled on September 29<sup>th</sup> amidst a full program of music and oration. The keynote address was delivered by the Association's president, Hon. Charles F. Libby. In it he expressed the hope that:

...to this spot, henceforth dedicated to the genius of Longfellow, future generations will come to pay their tribute of homage and respect to the poet and the man. So long as this statue shall endure it will stand as a silent reminder of the value of a pure and untarnished life, of noble endeavor directed to worthy ends.

Despite the passage of a century, this remarkable tribute to Longfellow continues to occupy a prominent place in downtown Portland amidst many of the buildings which were part of its original setting.

See continuation sheet

## 9. Major Bibliographical References

Craven, Wayne. Sculpture in America. New York: Thomas Y. Crowell Co., 1968.  
Eastern Argus (Portland). Issues of September 26 and October 1, 1888.

### Previous documentation on file (NPS):

- preliminary determination of individual listing (36 CFR 67) has been requested  
 previously listed in the National Register  
 previously determined eligible by the National Register  
 designated a National Historic Landmark  
 recorded by Historic American Buildings Survey # \_\_\_\_\_  
 recorded by Historic American Engineering Record # \_\_\_\_\_

See continuation sheet

### Primary location of additional data:

- State historic preservation office  
 Other State agency  
 Federal agency  
 Local government  
 University  
 Other

Specify repository:  
\_\_\_\_\_

## 10. Geographical Data

Acreage of property Less than 1

### UTM References

A 19 397800 4833890  
Zone Easting Northing  
C \_\_\_\_\_

B \_\_\_\_\_  
Zone Easting Northing  
D \_\_\_\_\_

See continuation sheet

### Verbal Boundary Description

The boundary of the nominated property is defined by granite curbing that rings a narrow grass strip located around the pedestal. This free-standing object stands at the southeast corner of State and Congress streets.

See continuation sheet

### Boundary Justification

The boundary embraces an oval space containing the pedestal and a grass strip around it. Historically, this is the extent of the monument. This area has survived without change despite adjacent street improvements and the installation of brick sidewalks around it.

See continuation sheet

## 11. Form Prepared By

name/title Kirk F. Mohny, Architectural Historian  
organization Maine Historic Preservation Commission date January, 1990  
street & number 55 Capitol Street telephone (207) 289-2132  
city or town Augusta, state Maine zip code 04333

United States Department of the Interior  
National Park ServiceNational Register of Historic Places  
Continuation SheetSection number 8 Page 2

Franklin Simmons was born in Webster, Maine in 1839, but spent his boyhood in Bath prior to returning near home to work in a cotton mill in Lewiston. His first drawing lessons were obtained about 1854, but this booming textile center offered little opportunity for further artistic training. After a short time spent in Boston with sculptor John Adams Jackson (also a Maine native), Simmons returned to Lewiston and opened a studio. For the next six years he specialized in portrait busts, but his first commission for a full length figure came in 1863 when he was asked to do a graveside memorial statue of General Hiram G. Berry, formerly of Rockland. In 1865 Simmons removed to Washington, D. C., and the following year received the commission for a Civil War monument in Lewiston; one of the first public commemorative statues of its type. Soon after it was erected in 1867 Simmons and his wife moved to Florence and then Rome where they established residence for the duration of their lives.

Prior to his obtaining the Longfellow commission in 1885, Simmons had created statues of Roger Williams and William King for Statuary Hall in the Capitol building. In 1877 his statue of Edward Little, one of Auburn, Maine's founders, was erected in front of the Edward Little High School. he had also been selected to design a Civil War memorial for Portland which was not finally completed and installed until 1891. It too survives a short distance from the Longfellow monument. Subsequent major works include the G.A.R. monument to General Grant and the equestrian statue of General John A. Logan in Iowa Circle, Washington, D.C. Simmons died in Rome in 1913.

The Longfellow statue is recognized by at least one historian of American sculpture as one of the artist's most significant commissions. Wayne Craven (Sculpture in America, 1968) sees in the bold massiveness of the figure:

...a measure of greatness never before realized in his [Simmons'] work. The eye is not distracted by details, and the real climax of the work is reached in the head, where the spectator is captivated by the pensive and sensitive expression.... It is indeed a finely conceived, well-wrought image of a 19<sup>th</sup> century American sage.

In the context of public statuary statewide the Longfellow monument stands among the best. Its sister statues in Auburn, Lewiston and Portland are significant as works by Simmons; the latter one especially so where the artist "... raised his art well above the banality of most American sculpture in the previous thirty years" (Craven, p. 299). The statues in Lewiston and the later one in Portland were both Civil War monuments, a fact which places

**United States Department of the Interior  
National Park Service**

## **National Register of Historic Places Continuation Sheet**

Section number 8 Page 3

---

them in a somewhat different historic context and certainly within a much larger group of such war memorials found throughout Maine. Public sculptures of historical figures are by comparison few in number. Given the recognized quality of the Longfellow monument there is little doubt of its statewide significance.

UNITED STATES DEPARTMENT OF THE INTERIOR  
NATIONAL PARK SERVICE

NATIONAL REGISTER OF HISTORIC PLACES  
EVALUATION/RETURN SHEET

REQUESTED ACTION: NOMINATION

PROPERTY Longfellow, Henry Wadsworth, Monument  
NAME:

MULTIPLE  
NAME:

STATE & COUNTY: MAINE, Cumberland

DATE RECEIVED: 3/07/90 DATE OF PENDING LIST: 3/20/90  
DATE OF 16TH DAY: 4/05/90 DATE OF 45TH DAY: 4/21/90  
DATE OF WEEKLY LIST:

REFERENCE NUMBER: 90000580

NOMINATOR: STATE

REASONS FOR REVIEW:

APPEAL: N DATA PROBLEM: N LANDSCAPE: N LESS THAN 50 YEARS: N  
OTHER: N PDIL: N PERIOD: N PROGRAM UNAPPROVED: N  
REQUEST: N SAMPLE: N SLR DRAFT: N NATIONAL: N

COMMENT WAIVER: N

ACCEPT  RETURN  REJECT 4/5/90 DATE Entered in the  
National Register

ABSTRACT/SUMMARY COMMENTS:

RECOM./CRITERIA \_\_\_\_\_  
REVIEWER \_\_\_\_\_  
DISCIPLINE \_\_\_\_\_  
DATE \_\_\_\_\_

DOCUMENTATION see attached comments Y/N see attached SLR Y/N

---

CLASSIFICATION

count       resource type

---

STATE/FEDERAL AGENCY CERTIFICATION

---

FUNCTION

historic       current

---

DESCRIPTION

architectural classification  
 materials  
 descriptive text

---

SIGNIFICANCE

Period      Areas of Significance--Check and justify below

Specific dates      Builder/Architect  
Statement of Significance (in one paragraph)

summary paragraph  
 completeness  
 clarity  
 applicable criteria  
 justification of areas checked  
 relating significance to the resource  
 context  
 relationship of integrity to significance  
 justification of exception  
 other

---

BIBLIOGRAPHY

---

GEOGRAPHICAL DATA

acreage       verbal boundary description  
 UTM's       boundary justification

---

ACCOMPANYING DOCUMENTATION/PRESENTATION

sketch maps     USGS maps     photographs     presentation

---

OTHER COMMENTS

Questions concerning this nomination may be directed to

\_\_\_\_\_ Phone \_\_\_\_\_

Signed \_\_\_\_\_ Date \_\_\_\_\_



LONGFELLOW, HENRY WADSWORTH,

MONUMENT

PORTLAND, MAINE

ROBERT G. REED

1/1990

MHPC

VIEW FROM SOUTH

1 OF 2



LONGFELLOW, HENRY WADSWORTH,  
MONUMENT

PORTLAND, MAINE  
ROGER G. REED

1/1990  
MHPC  
DETAIL  
2 of 2

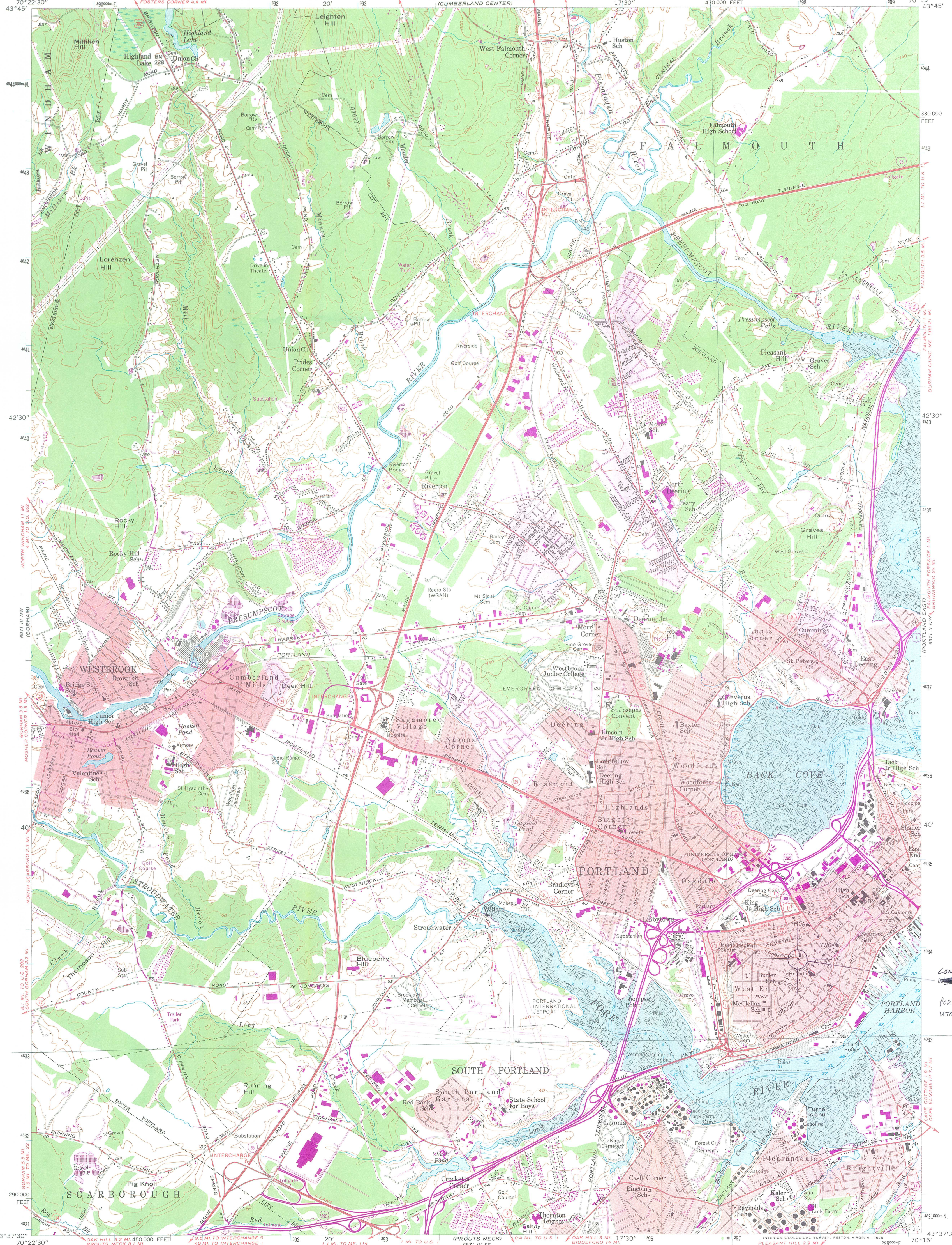

Mapped by the Army Map Service  
Edited and published by the Geological Survey  
Control by USGS, USC&GS, and USCE  
Culture and drainage in part compiled from aerial  
photographs taken 1943  
Topography by planetable surveys 1944  
Culture revised by the Geological Survey by photogrammetric  
methods from aerial photographs taken 1956. Field check 1956  
Selected hydrographic data compiled from USC&GS chart 325 (1955)  
This information is not intended for navigational purposes  
Polyconic projection. 1927 North American datum  
10,000-foot grid based on Maine coordinate system; west zone  
100-meter Universal Transverse Mercator grid ticks,  
zone 19, shown in blue  
Red tint indicates areas in which only landmark buildings are shown

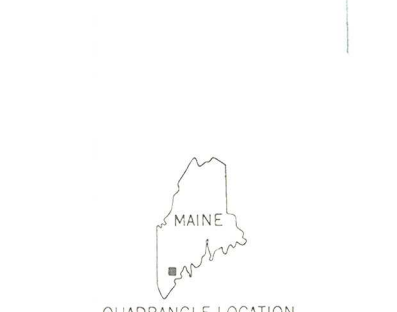
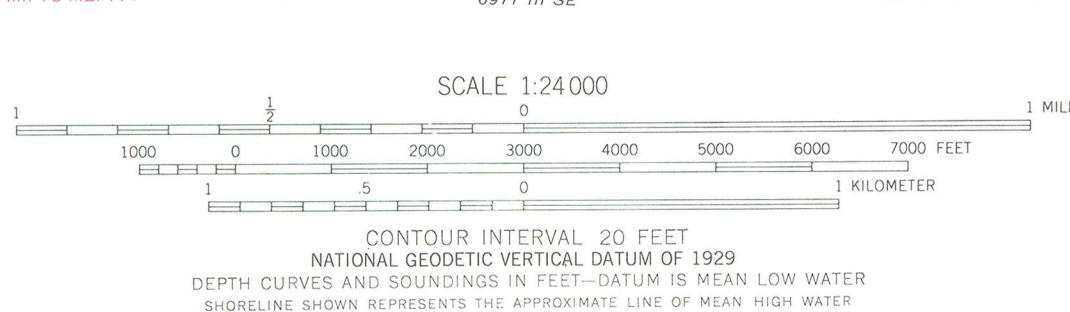
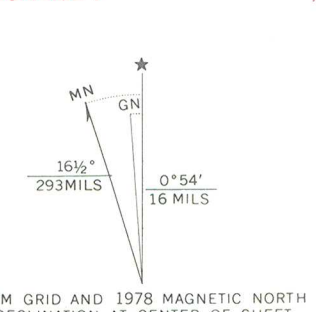

ROAD CLASSIFICATION  
Heavy duty ——— Light-duty ———  
Medium-duty ——— Unimproved dirt ———  
U. S. Route ——— State Route ———  
Interstate Route ———  
PORTLAND WEST, ME.  
NE/4 PORTLAND 15' QUADRANGLE  
N43375-W70157.5

1956  
PHOTOREVISED 1978  
AMS 6971 III NE - SERIES V811

THIS MAP COMPLIES WITH NATIONAL MAP ACCURACY STANDARDS  
FOR SALE BY U. S. GEOLOGICAL SURVEY, RESTON, VIRGINIA 22092  
A FOLDER DESCRIBING TOPOGRAPHIC MAPS AND SYMBOLS IS AVAILABLE ON REQUEST

LONGFELLOW HENRY WADSWORTH,  
MONUMENT  
PORTLAND, MAINE  
UTM: 19J397800/4833890



Earle G. Shettleworth, Jr.  
Director

MAINE HISTORIC PRESERVATION COMMISSION  
55 Capitol Street  
State House Station 65  
Augusta, Maine 04333

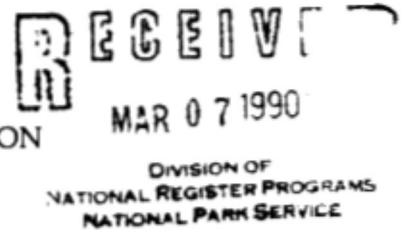

Telephone:  
207-289-2133

February 27, 1990

National Register of Historic Places  
National Park Service  
P. O. Box 37127  
Washington, DC 20013-7127

To Whom It May Concern:

Enclosed please find six nominations and a Multiple Property Submission cover document. The latter item covers Maine lifesaving stations, one of which is included in this package.

If you have any questions regarding this matter do not hesitate to contact me.

Sincerely,

  
Kirk F. Mohny  
Architectural Historian

Enclosures

KFM/tls