

APR 02 2009



403

United States Department of the Interior  
National Park Service

National Register of Historic Places  
Registration Form

This form is for use in nominating or requesting determinations for individual properties and districts. See instructions in *How to Complete the National Register of Historic Places Registration Form* (National Register Bulletin 16A). Complete each item by marking "x" on the appropriate line or by entering the information requested. If an item does not apply to the property being documented, enter "N/A" for "not applicable." For functions, architectural classification, materials, and areas of significance, enter only categories and subcategories from the instructions. Place additional entries and narrative items on continuation sheets (NPS Form 10-900a). Use a typewriter, word processor, or computer, to complete all items.

1. Name of Property

historic name HOTEL RANDOLPH

other names/site number Randolph Hotel

2. Location

street & number 200-204 Fourth Street N/A not for publication

city or town Des Moines N/A vicinity

state Iowa code IA county Polk code 153 zip code 50309

3. State/Federal Agency Certification

As the designated authority under the National Historic Preservation Act, as amended, I hereby certify that this ( nomination  request for determination of eligibility) meets the documentation standards for registering properties in the National Register of Historic Places and meets the procedural and professional requirements set forth in 36 CFR Part 60. In my opinion, the property ( meets  does not meet) the National Register criteria. I recommend that this property be considered significant ( nationally  statewide  locally). ( See continuation sheet for additional comments.)

Bonnie Mitchell DSHPO April 16 2009  
Signature of certifying official/Title Date

**STATE HISTORICAL SOCIETY OF IOWA**

State or Federal agency and bureau

In my opinion, the property ( meets  does not meet) the National Register criteria. ( See continuation sheet for additional comments.)

Signature of certifying official/Title Date

State or Federal agency and bureau

4. National Park Service Certification

I hereby certify that the property is:

- entered in the National Register.
  - See continuation sheet.
- determined eligible for the National Register
  - See continuation sheet
- determined not eligible for the National Register
- removed from the National Register.
- Other, (Explain)

Edson W. Beall 6.11.09  
Signature of Keeper Date of Action

Hotel Randolph  
Name of Property

Polk County, Iowa  
County and State

**5. Classification**

**Ownership of Property** (Check as many lines as apply)  
**Category of Property** (Check only one line)

- private
- public-local
- public-State
- public-Federal
- building(s)
- district
- site
- structure
- object

**Number of Resources within Property**  
(Do not include previously listed resources in the count.)

Contributing	Noncontributing	
1	0	buildings
		sites
		structures
		objects
1	0	Total

**Name of related multiple property listing**  
(Enter "N/A" if property is not part of a multiple property listing)

N/A

**Number of contributing resources  
previously listed in the National Register**

N/A

**6. Function or Use**

**Historic Functions**  
(Enter categories from instructions)

DOMESTIC/hotel

**Current Functions**  
(Enter categories from instructions)

DOMESTIC/hotel

**7. Description**

**Architectural Classification**  
(Enter categories from instructions)

LATE 19TH AND 20TH CENTURY REVIVALS/  
Classical Revival

LATE 19TH AND EARLY 20TH CENTURY AMERICAN MOVEMENTS/  
Chicago

**Materials**  
(Enter categories from instructions)

foundation Concrete

walls Brick

roof Asphalt

other Ceramic Tile

**Narrative Description**

(Describe the historic and current condition of the property on one or more continuation sheets.)

**United States Department of the Interior**  
National Park Service

**NATIONAL REGISTER OF HISTORIC PLACES**  
**CONTINUATION SHEET**

Section number 7

Page 1

CFN-259-1116

---

Hotel Randolph, Polk County, Iowa.

**DESCRIPTION OF PHYSICAL APPEARANCE**

*SITE DESCRIPTION*

Completed in 1912, the Hotel Randolph is located in the southern portion of Des Moines' commercial downtown. During the late 19<sup>th</sup> century and much of the 20<sup>th</sup> century, this area formed the core of the city's downtown. Later, the downtown moved several blocks to the north and west, leaving this area to serve as the city's warehouse district and subsequently to languish. Throughout its history, this area, now known as the Court Avenue district, has derived its commercial importance from its proximity to the railroads. Today, the area is under intense redevelopment with new construction and adaptive reuse of historic buildings.

The Hotel Randolph is situated on the west side of Fourth Street, on the northwest corner of the street's intersection with Court Avenue. The hotel is sited on a fractional parcel of Lots 7 and 8 in Block 21 of the Fort Des Moines plat, with a footprint of approximately 67 x 68 feet. The hotel possesses two primary façades. One faces east, and the other faces south. The main entrance to the building is on its east elevation. Commercial buildings abut the Randolph on its north and west elevations—the Youngerman Block, a three-story, masonry building constructed in 1876, on the north and the Earle & LeBosquet Block, a four-story building built in 1896 on the west. A public sidewalk runs flush to the building on the east and the south, providing access to the building's pedestrian entrances.

As indicated, the Hotel Randolph is located in an historic area in the southern portion of downtown Des Moines. Other historic resources in the area include the Seth Richards Commercial Block (NRHP, 2005) at 300-310 Court Avenue, the Des Moines Saddlery Company Building (NRHP, 1985) at 307-311 Court Avenue, the Polk County Courthouse (NRHP, 1979) at the west end of Court Avenue where the street terminates at West 5<sup>th</sup> Street, and the Youngerman Block at 206-208 Fourth Street, which was certified as individually eligible for National Register listing. The Hotel Row Historic District, with properties facing both sides of Fourth Street between Walnut Street and Court Avenue, was determined National Register eligible by the State Historical Society of Iowa on November 1, 2007.

*BUILDING DESCRIPTION*

The 8-story Hotel Randolph was constructed in 1912 as the first tall and only "absolutely fireproof hotel" in the city.<sup>1</sup> H. L. Stevens Co., its architect, extensively utilized reinforced concrete for its construction.

---

<sup>1</sup> City Directory, 1913. Between pp. 230-231.

United States Department of the Interior  
National Park Service

**NATIONAL REGISTER OF HISTORIC PLACES  
CONTINUATION SHEET**

Section number 7

Page 2

CFN-259-1116

---

Hotel Randolph, Polk County, Iowa.

This use included the building's structural support system, foundation, floors, and roof. Together these materials offered the era's best protection against the threat of fire and enabled buildings to rise to greater height than hitherto practical.

Structural Engineering

A plan view of the Hotel Randolph reveals the structural configuration of its reinforced concrete system. A total of 20 concrete columns with vertical steel rods embedded in them form the vertical support for the building. A north-south row of five columns, placed 15-foot 10-inches apart on center, is repeated four times across the east-west footprint of the building at 21-foot 2-inch on-center intervals. The columns measure about 26 x 26 inches in section. (See Continuation Sheets 7-16 and 7-17.) A series of concrete beams, embedded with reinforced horizontal steel rods, spans these columns. These beams measure about 18 inches deep. The upper stories of the building feature floor slabs embedded with horizontal steel rods laid in a grid pattern.

This framework and floor design is then is repeated floor upon floor to the top of the building. The use of concrete and steel complement one another. The concrete bears the weight of the building and protects the steel from damage by intense heat from fire. The reinforcing rods and some steel mesh add tensile strength to the framework. Concrete lacks tensile strength. Some of the reinforced columns and beams are visible on the north and west elevations of the building, which were never clad with brick veneer. (Of course, the reinforcing rods are not visible.) Some of the beams are evident in the interior of the building where they run, covered with plaster, just beneath the ceilings in certain areas of the halls and rooms.

This structural system is visible on the north elevation of the building. The face of the raw concrete is visible as columns and beams. This reinforcing rod system is also internally visible in the basement of the hotel. Some discrete spalling has occurred on some overhead beams in the basement. The embedded rebar in the concrete has corroded and marked horizontal lines running the length of the beams. A recent structural engineering report has pointed out this condition and recommended its repair before the problem becomes a serious concern.<sup>2</sup>

This report did not examine by non-destructive or destructive testing to determine the building's concrete strength or reinforcement layout, but concluded that, given a future use similar to its present one, the building is "generally in good condition and could be used for the desired purpose."<sup>3</sup>

---

<sup>2</sup> Saul, p. 2.

<sup>3</sup> *Ibid.*, p. 5.

**United States Department of the Interior**  
National Park Service

**NATIONAL REGISTER OF HISTORIC PLACES**  
**CONTINUATION SHEET**

Section number 7

Page 3

CFN-259-1116

---

Hotel Randolph, Polk County, Iowa.

Exterior

The brick-faced building rises to eight stories from its full basement. With exterior measurements of approximately 67 x 68 feet, the hotel reads as square at its base, although, with an interior ventilation shaft, it is actually u-shaped. The building features brick masonry curtain walls on the exterior. A penthouse surmounts the top story and includes space for elevator hoisting equipment and an access to the roof. A sidewalk vault stands on the south side of the building with an elevator in the basement to move goods to and from the street. A wrought iron fence surrounds the vault on two sides.

Although the Hotel Randolph's construction technology is its most significant feature (see Section 8 of this nomination), the stylistic influences of the building's double façade are most apparent to the casual observer. As an architect-designed resource, we expect an elevated sense of awareness of both technological and stylistic trends, and, in the Hotel Randolph, we get both. As a corner building, the dual façades of the Hotel Randolph contain an equal share of the building's stylistic detailing, the best of the building's construction materials, and the highest attention to detail. The building's secondary elevations (west and north) reveal the network pattern of its reinforced concrete system. Common brick infills the spaces between this network. Isolated sections of these elevations are parged with stucco—likely a response to deterioration of the brick infill.

As it stands today, the hotel's ground level facade is a c.1950 remodeling of the original 1912 storefront. As part of that mid-century makeover, burnt-red ceramic tiles were installed over the original cream-colored brick and cast concrete. A new marquee was also installed on the east elevation of the building along with a neon sign built on the roof of the Earle & Youngerman Block at 407-409 Court Avenue. (By this time, the title to that block had come into the possession of the hotel's ownership.) This sign remains extant and reads "Hotel/Randolph" in curvilinear lettering. Building permits and historic images suggest that all of this remodeling occurred at the same time as the hotel's lobby renovation. The modern, streamlined appearance of the marquee, neon sign, and lobby design (see below) further supports that date.

This rehabilitation comes off as a quick and easy cover-up of aging materials, made all the more apparent when compared to the Youngerman Block next door at 206-208 Fourth Street. There, a similar albeit earlier face-lift resulted in a design that, while divergent from the building's original Italianate styling, is aesthetically appealing. The Randolph update was considerably less successful, in large part because it lacked the character-defining details utilized in the Youngerman Block. (A National Register nomination of that property is in preparation at this time as well.) The Randolph update has also proved structurally unsound. According to a recent engineering report:

United States Department of the Interior  
National Park Service

**NATIONAL REGISTER OF HISTORIC PLACES  
CONTINUATION SHEET**

Section number 7

Page 4

CFN-259-1116

---

Hotel Randolph, Polk County, Iowa.

We noticed some cracks in the red terracotta [*sic*] at the corner of the building at intersection of 4th street and Court Avenue. It appears that a metal frame was built at some point in time at the opening of Iowa Bail Bond's office [200 Fourth Street] facing Court Avenue above the stair that leads to the basement. It appears that the frame was built to arrest the distress as mentioned above.<sup>4</sup>

These alterations to the Randolph's façade appear to have been completed in the early 1950s. The façade alterations also included the application of ceramic tile over the existing buff-colored brick and the removal of cast concrete window sills on the east and south elevations of the building and their replacement with brick.

The Court Avenue and Fourth Street elevations of the Hotel Randolph clearly express the tenets of the Chicago Commercial Style, which utilized the tripartite organization of the façade.<sup>5</sup> Such a scheme called for the division of the elevation into base, shaft and capital, creating a visual organization. As designed, that approach was manifested in the Hotel Randolph by the readily apparent differentiation between the ground level facade, the upper stories, and the cornice. Today a measure of that early clarity is absent due to the modernization of the ground level façade and the loss of the cornice. It seems appropriate that the architect looked to Chicago for design inspiration as the city was on the cutting edge of architectural change, both stylistically and technologically; many of the principles regarding fireproofing also sprang from that city. In this way, the Hotel Randolph was clearly an offspring of the Chicago school.

The Chicago Commercial Style's tripartite scheme plays out in the Hotel Randolph with the design of a solid footing or base, which has been noted as altered, but intact. From that base, a concrete running sill marks the point of transition to the "shaft" of red brick that rises seven stories and across two full elevations. The brick of the upper stories is set in a running bond with a flush joint. Each of these elevations is visually organized into four bays (east elevation) and three bays (south elevation) through the use of recessed panels. Within each recessed panel, windows are grouped at each floor into sets of three, with the middle window slightly larger than the two that flank it. This organizational grid creates a sense of control, a feeling that is heightened by the use of header bricks, employed in a manner that creates a grid within the larger grid. When scrutinized more thoroughly, this simple method of using turned bricks to create ornament has been used masterfully. The architect has created subtle, yet complex patterns across the face of the recessed panels. The introduction of small rations of cream-colored brick (a match to the historic ground level façade) seems almost an afterthought.

---

<sup>4</sup> *Ibid.*, 3.

<sup>5</sup> Condit, Carl W.

**United States Department of the Interior**  
National Park Service

**NATIONAL REGISTER OF HISTORIC PLACES**  
**CONTINUATION SHEET**

Section number 7

Page 5

CFN-259-1116

---

Hotel Randolph, Polk County, Iowa.

The transition from the upper stories to the cornice is accomplished through the use of a series of consoles, which are mounted at the top of the wall face over a brick beltcourse and in a position that suggests the capital on a column. Historic images indicate that these consoles were originally visually connected with the now-missing cornice. Three cream-colored panels stretch the width of the bays of the upper stories and mark the end of the shaft. When constructed, the Randolph sported a prominent, pressed metal cornice; historic images document its appearance. (See Continuation Sheets 7-14 and 7-15.) The building's cornice was removed due to its significant deterioration and the instability of the parapet wall to which it was anchored. A portion of the cornice and one of its huge brackets have been saved to provide an accurate model for the restoration of the building's "capital" to its place in the original tripartite design.

The upper floors on the east and south elevations of the building feature regularly placed windows with 1/1 double-hung wood sash. These windows are in fair condition and likely original to the building. The original window sills were likely of cast concrete but were replaced, possibly circa 1950, with rowlock-laid brick. The north and west elevations feature 2/2 double-hung wood sash with cast concrete sills original to the building. Some of the sills have been parged with stucco. Several of the original sash on the north and west facades have been replaced with 1/1 double-hung designs.

Interior

The Hotel Randolph functions today much as it did when the hotel opened on February 1, 1912. The ground level has historically served as the hotel lobby, while the upper stories have accommodated guest rooms. In addition to these primary functions, other enterprises such as a pharmacy, a restaurant, and a cafeteria have operated from the hotel. Although the function of the building has remained generally the same, the interior has seen some significant changes.

The ground level of the Hotel Randolph functions as its lobby – true both historically and currently. The lobby is entered from either the primary entrance on Fourth Street, which is marked by a large sign/awning, or a smaller entrance on Court Avenue. As the floor plan indicates, the first floor is laid out in a grid created by the interior support columns. Simply speaking, the grid measures four bays (east) by three bays (south). The lobby of the Randolph fills three-quarters of the first floor.

In its present condition, the Hotel Randolph's lobby reflects what is believed to be an early 1950s renovation, with some later updates evident in finish materials such as carpeting. The elongated front desk with its streamlined profile and curved end, the grillwork in the soffit above the desk, curved edges on the support columns, a wall of mirror, chrome and glass ceiling light fixtures, and a curved, wooden

**United States Department of the Interior**  
National Park Service

**NATIONAL REGISTER OF HISTORIC PLACES**  
**CONTINUATION SHEET**

Section number 7

Page 6

CFN-259-1116

---

Hotel Randolph, Polk County, Iowa.

header marking the lobby's exit onto "Court Avenue" reflect the modern, aerodynamic forms that came into vogue in the years following World War II. This motif is carried from the lobby to the north staircase of marble and polished granite and up to the Wedding Suite where the simple elegance of the streamlined wood with curved edges highlights this special accommodation. The feeling associated with this modern stylistic motif rests easily in the smooth marble and granite that is original to the hotel.

The specifics of the mid-century remodeling are not currently known. The addition of the above named elements seems sure. It is also believed that the historic mezzanine, which now accommodates the Wedding Suite, was enclosed at this time. Further research would paint a more thorough picture of the lobby's alterations.

Also located on the first floor of the hotel are three commercial spaces – one set at the corner of Court and Fourth, one immediately to the right (north) of the Fourth Street entrance, and one to the right (east) of the Court Avenue entrance. Each of these commercial spaces has entrances from the street as well as from the lobby. All of the historic occupants of these rooms have not been specifically identified, but historic news accounts and advertisements document that in April of 1912 the Hotel Randolph Café opened and that in 1913 the Hotel Randolph Company Modern Pharmacy was located in the hotel. At various other times in its history, the hotel also had a barbershop and other eating establishments. Commercial enterprises continue to occupy the spaces. Today, they reflect a variety of remodeling efforts, with replacement storefront windows, dropped ceilings, and contemporary wall finishes.

As to the basement - judging from the level of attention given to its finish materials, this space was designed to accommodate a commercial function. The stairs leading from the hotel lobby to the basement feature the historic marble and polished granite, with a streamlined, chrome handrail added during the 1950s renovation. The basement itself features areas finished in terrazzo floors and polished granite walls. An April of 1912 news article announcing the opening of the Hotel Randolph Café indicates that the eatery was accessible from the interior, lobby space and the street. Further, the article described "white Italian marble steps with green marble trim," which suggests that the café may have been located in the hotel's basement.<sup>6</sup> Today the basement level accommodates a laundry and storage.

The upper floors of the Hotel Randolph are devoted to sleeping rooms and the service spaces that support that function. The second through eighth story floor plans are nearly identical. As indicated, the hotel is shaped as a "U", with the majority of the interior rooms looking out on a ventilation shaft and the majority of the exterior rooms overlooking Court Avenue or Fourth Street. The hotel elevator, which serves every level of the building, is located on the north wall.

---

<sup>6</sup> *Waterloo Daily Reporter*. April 18, 1912.

**United States Department of the Interior**  
**National Park Service**

**NATIONAL REGISTER OF HISTORIC PLACES**  
**CONTINUATION SHEET**

Section number 7

Page 7

CFN-259-1116

---

Hotel Randolph, Polk County, Iowa.

As the referenced floor plan indicates, the upper story spaces are defined by the U-shaped hall that threads through them. The hallways are approximately 6 feet wide with ceiling heights of about 10 feet. The walls and ceilings of the hallways retain their historic plaster finishes with base, crown, and chair rail moldings remaining intact. Most of the doors to hotel rooms are in place, complete with historic trim, hardware, and room numbers; some have had their transoms removed. No historic light fixtures were noted in the hallways. A mail tube, which is located across the hallway from the elevator, is accessible at each floor of the hotel. Most interesting in the hallways are the 18-inch beams that protrude from the ceiling as a reminder of the building's reinforced concrete structural system.

The rooms themselves vary in size and shape, but are spare in decorative embellishment. They are also small. The largest contain only about 290 square feet (including separate bathroom), while others are yet smaller. Rooms generally feature plaster walls and ceiling finishes. Bathrooms feature original ceramic tile floors and fixtures and an original wash sink in the sleeping room itself. Windows and doors are trimmed in oak with original finishes. As indicated, many of the rooms look out over the ventilation shaft. The windows of those that do, feature metal wire infill as a fire safety measure. The upper story windows of the Hotel Randolph are double-hung with a one-over-one light configuration. While many appear to retain their wood frames, others have been replaced with aluminum and still others filled by glass structural blocks.

Plans to enlarge the Hotel Randolph never came to fruition. (See Continuation Sheet 14.) Instead, James Hewitt annexed the upper two stories of the property at 206-208 Fourth Street (the Youngerman Block) to use as sleeping rooms. To accommodate this transition, doors were cut between the two buildings at the second and third floors. The new openings required a short set of steps to connect the Randolph to the Youngerman's greater floor height and fire doors were inserted. The fire doors closed when heat from a fire melted wax inserts in chains attached to balancing weights. When the chains separated, the weights dropped and shut the doors. These doors and their mechanisms remain in place.

Today, the Hotel Randolph functions much as it did at the time of its construction. Its use as low-income housing allowed for a functional transition that required little alteration of the mid-1950s appearance. As a result, the property continues to contribute to the community that it serves and to the general economic health of this commercial area.

*ALTERATIONS*

Alterations to the Hotel Randolph include a circa 1950 remodeling of the Court Avenue and Fourth Street storefronts and lobby, the removal of an original pressed metal cornice surmounting these two facades,

United States Department of the Interior  
National Park Service

**NATIONAL REGISTER OF HISTORIC PLACES**  
**CONTINUATION SHEET**

Section number 7

Page 8

CFN-259-1116

---

Hotel Randolph, Polk County, Iowa.

the replacement of the original concrete window sills on the east and south elevations with brick sills, and the installation of replacement aluminum windows on the east and south elevations.

*INTEGRITY CONSIDERATIONS*

The Hotel Randolph retains a very high level in five aspects of historic integrity: location, design, workmanship, feeling, and association.

Because the Hotel Randolph remains on its original site, the level of integrity as it relates to *location* is excellent.

The integrity of the building as it relates to its engineering *design* is excellent. The integrity of its architectural design is good. The Randolph's significance, under Criterion C, relates specifically to its reinforced concrete engineering. This system remains fully intact today and clearly visible at the rear of the building. There, on the exterior walls, the system's concrete columns and beams remain fully exposed to view. These walls were never veneered with brick or painted, so the viewer can easily see the horizontal and vertical patterns formed by the building's exposed reinforced concrete system. Although the loss of the hotel's pressed metal cornice is regrettable, original pieces of it remain intact, including one of its heavy brackets, and can be used as models for replacement. Although the upper floors on the east and south elevations now have aluminum windows, their design reflects the 1/1 double-hung sash configuration original to the building.

One note is needed concerning the hotel's present storefront. Installed circa 1950, its design used the storefront renovation of the Youngerman Block next door at 206-208 Fourth Street as its model. Although the hotel's renovation used the same Chinese red and Nile green ceramic tile, the design of the hotel's renovation lacked the architectural detailing of the Youngerman property. Indeed, the hotel's renovation is now unstable. Its ceramic tile has begun to fall off. This tile was installed over a slick, white glazed brick. The brick was not scored beforehand. As a result, the adhesive agent did not take a tight bond to the wall and, deteriorating with age, is losing its bonding capability. This has not occurred at the Youngerman Block. That block's original storefront was entirely removed in its 1935 renovation, and the installation of its new storefront was total.

The integrity of the Hotel Randolph's *setting* is good. At the intersection of Fourth Street and Court Avenue, the hotel stands just as it did during the building's period of significance (1912), with a bird's-eye view of the bustling commercial district surrounding it. Many of the buildings that line both sides of

United States Department of the Interior  
National Park Service

**NATIONAL REGISTER OF HISTORIC PLACES  
CONTINUATION SHEET**

Section number 7

Page 9

CFN-259-1116

---

Hotel Randolph, Polk County, Iowa.

Fourth Street from Court Avenue on the south to Walnut Street on the north date from the late 19<sup>th</sup> and early 20<sup>th</sup> centuries. As the largest building in the immediate vicinity, the Randolph dominates the scene.

The integrity of the Hotel Randolph as it relates to *materials* remains good. The retention of the construction materials used in the hotel's design is paramount. This applies not only to the structural system, but also to other fire safety measures such as the use of wire embedded in window glazing. In addition, the retention of stylistic elements of the Chicago Commercial Style, contributes to the integrity of materials. This applies particularly to the retention of the window openings of the façade, which, as part of the tripartite scheme and the organizational grid employed by the architect, is especially important. As a note, the loss of the building's cornice diminishes that integrity, but plans to recreate it using historic images and actual remnants are underway. The replacement of the building's original concrete sills with brick sills has been noted above.

The outstanding integrity of the building's *workmanship* again relates to the building's structural system, which, while not overtly visible in most areas, is the core of the building's construction. Beams are exposed in portions of upper story hallways and in some rooms and provide a reminder of the structure. The architect's care in the design of the façade further contributes to the hotel's integrity of workmanship.

The Hotel Randolph retains an excellent *feeling* of its historic function. Throughout its history the hotel has served a housing-related capacity; today it provides low-income housing in the former hotel rooms. The construction of the hotel firmly established the within the context of its commercial surrounding and continues today visually to anchor to the district's vitality.

The building also retains a high level of integrity as it relates to *association*. Visitors from its period of significance would readily recognize the building and its surroundings today.

*FUTURE PLANS*

The Randolph Corner, L.L.C., is currently planning a rehabilitation of the Hotel Randolph in conjunction with that of its neighbors, the Earle & LeBosquet Block at 407-409 Court Avenue and the Youngerman Block at 206-208 Fourth Street. The intent of these rehabilitation efforts is to convey these buildings into low- and moderate-income rental housing. The plan calls for the use of federal and state historic preservation tax credits to help fund the projects.

United States Department of the Interior  
National Park Service

# NATIONAL REGISTER OF HISTORIC PLACES CONTINUATION SHEET

Section number 7

Page 10

CFN-259-1116

Hotel Randolph, Polk County, Iowa.

## SITE MAP

ARROW LOCATES PROPERTY

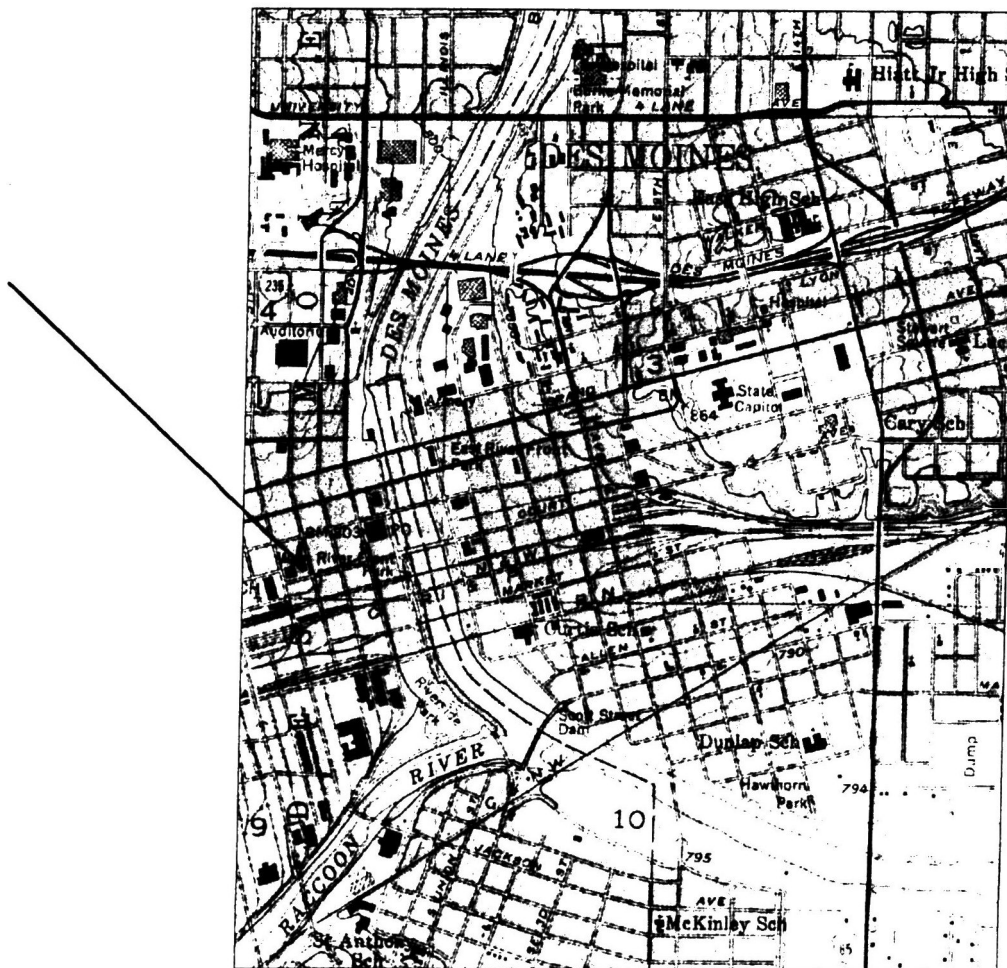

United States Department of the Interior  
National Park Service

# NATIONAL REGISTER OF HISTORIC PLACES CONTINUATION SHEET

Section number 7

Page 11

CFN-259-1116

Hotel Randolph, Polk County, Iowa.

## 1920 SANBORN FIRE INSURANCE MAP

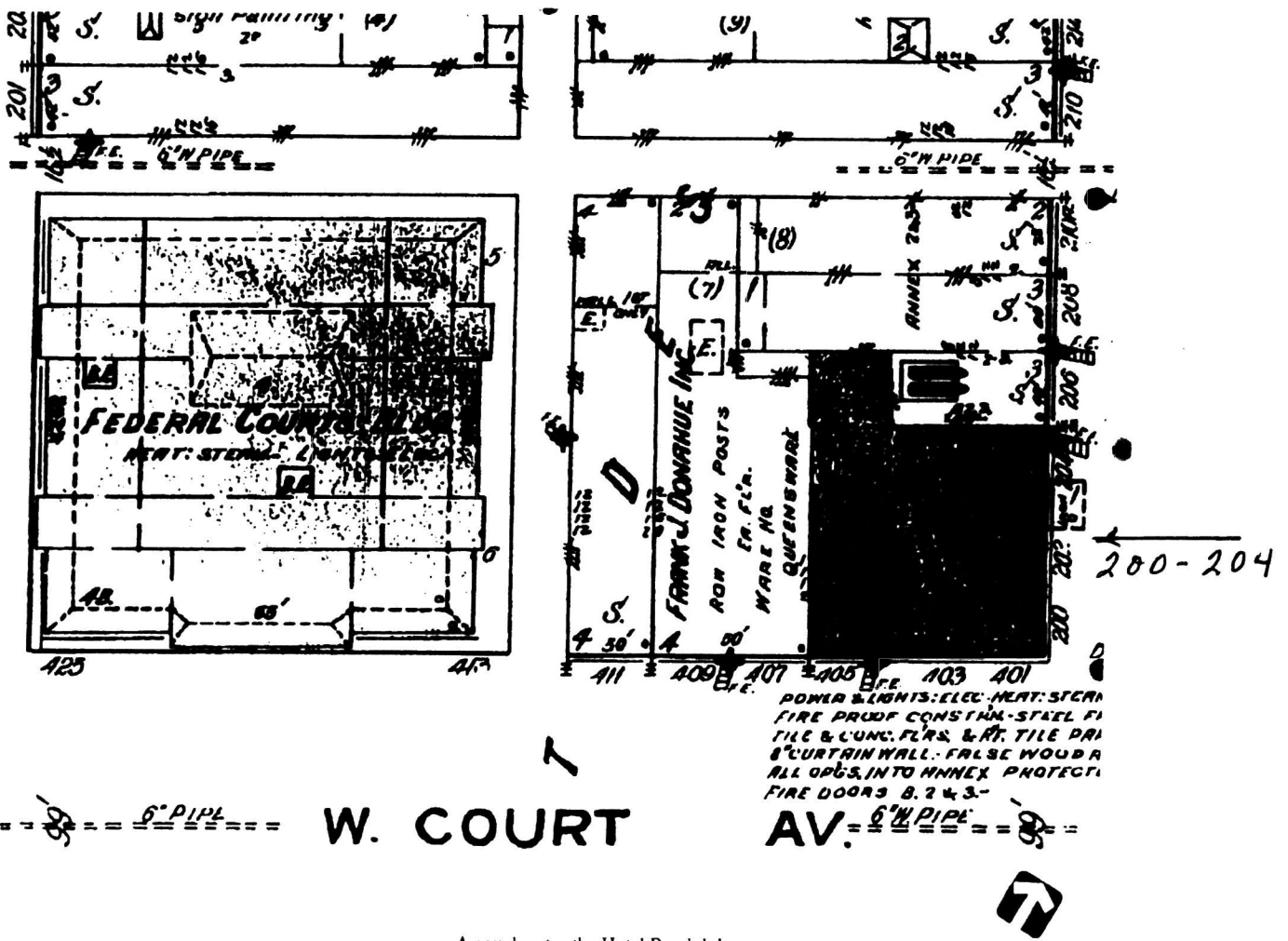

Arrow locates the Hotel Randolph.

Source: Sanborn Map Company, 1920.

United States Department of the Interior  
National Park Service

## NATIONAL REGISTER OF HISTORIC PLACES CONTINUATION SHEET

Section number 7

Page 12

CFN-259-1116

Hotel Randolph, Polk County, Iowa.

### UNDER CONSTRUCTION 1911

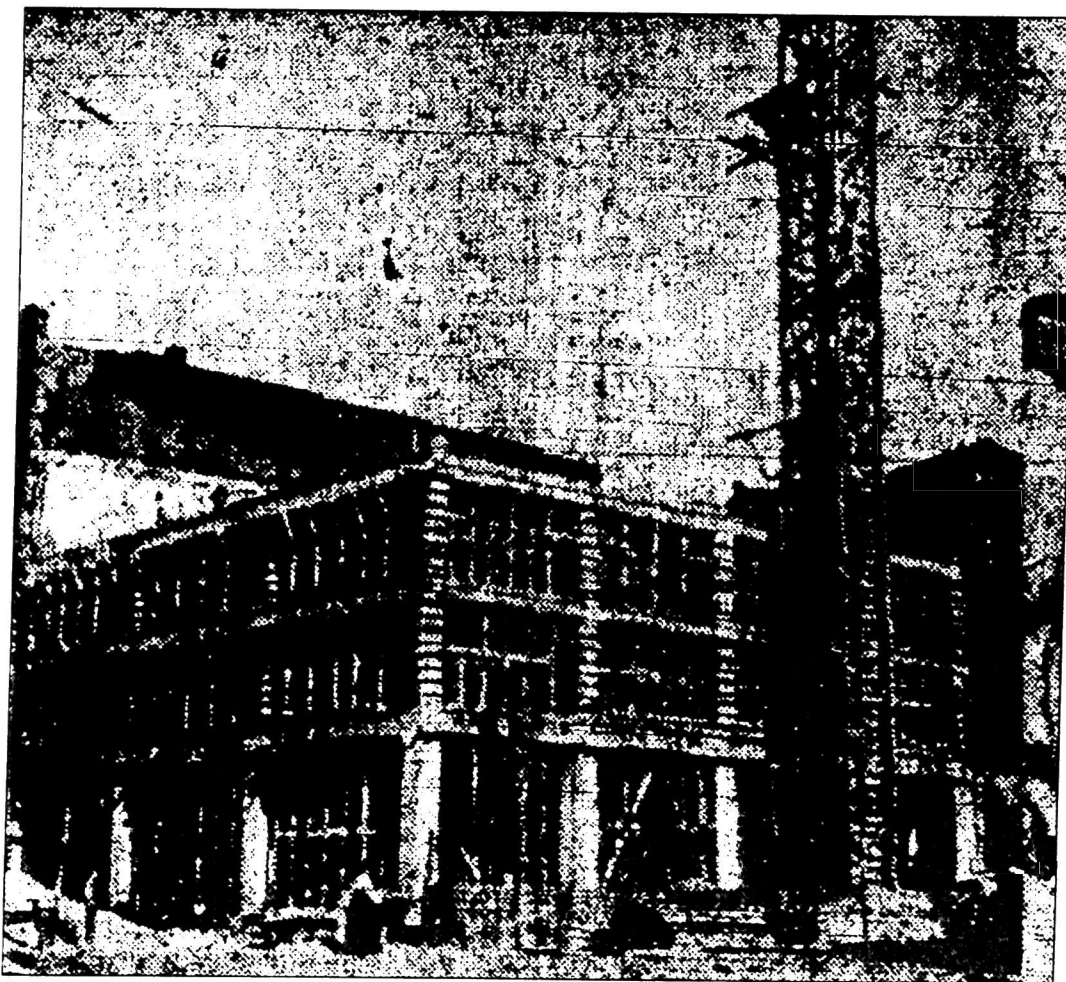

"Concrete work for three stories has been completed on the new eight story hotel building being erected on the northwest corner of Fourth street and Court avenue by Judge James Hewitt. The fourth story is nearly completed. The picture shows the progress made on the building and the huge scaffolding used to hoist the concrete." Wood shoring stands between the heavy columns and beams to support the forms into which the concrete is poured.

Source: *Des Moines Register & Leader*, July 23, 1911.

United States Department of the Interior  
National Park Service

## NATIONAL REGISTER OF HISTORIC PLACES CONTINUATION SHEET

Section number 7

Page 13

CFN-259-1116

Hotel Randolph, Polk County, Iowa.

### HOTEL RANDOLPH 1912

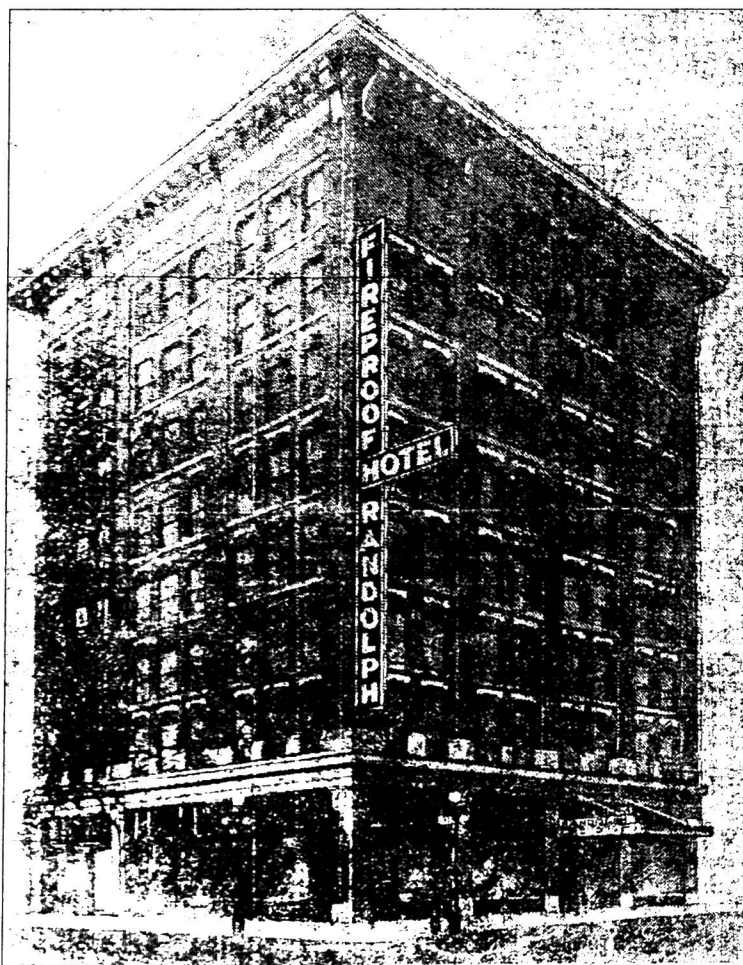

This photograph pictures the Hotel Randolph at the time of its opening. A giant sign touts the building's fireproof construction. Although pasted on the photograph as a montage rather than actually mounted on the building, the sign calls attention to the power of fireproof construction to attract the traveling public.

Source: *Des Moines Register*, February 1, 1912.

United States Department of the Interior  
National Park Service

# NATIONAL REGISTER OF HISTORIC PLACES CONTINUATION SHEET

Section number 7

Page 14

CFN-259-1116

Hotel Randolph, Polk County, Iowa.

## HOTEL RANDOLPH 1914

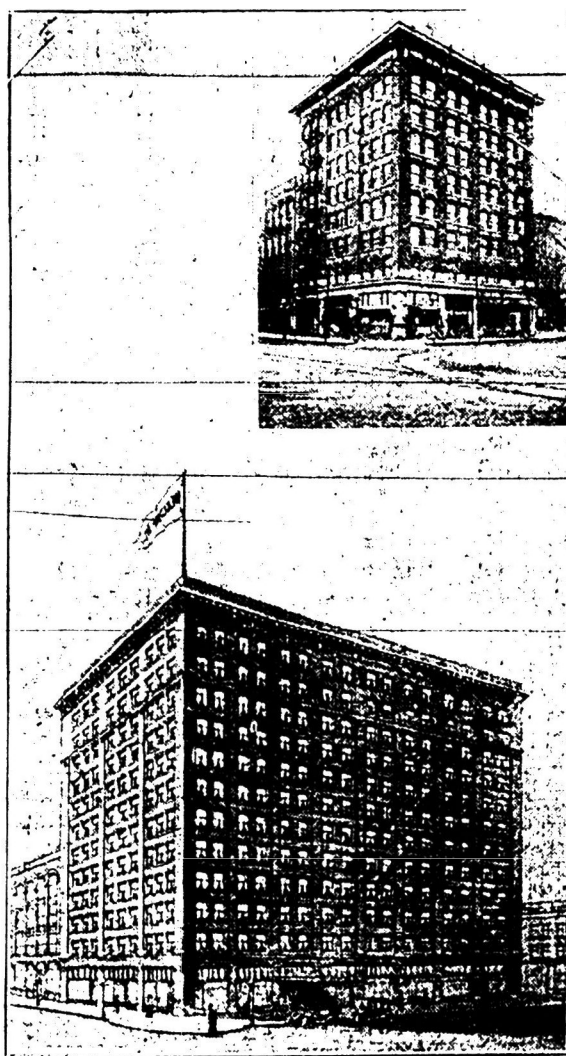

Under the headline "Proposed Hotel Improvement," this newspaper feature announced a major expansion of the Hotel Randolph. The 1912 building is pictured above with the proposed enlargement below. This improvement never took place.

Source: *Des Moines Register*, February 15, 1914.

United States Department of the Interior  
National Park Service

## NATIONAL REGISTER OF HISTORIC PLACES CONTINUATION SHEET

Section number 7

Page 15

CFN-259-1116

Hotel Randolph, Polk County, Iowa.

### HOTEL RANDOLPH CIRCA 1950



This drawing of the Hotel Randolph emphasizes its height by looking upwards to a vast amount of sky.  
The drawing was probably completed soon after the Boss Hotel chain purchased the building.

Source: Unreferenced ephemera courtesy of Randolph Investment Company.

United States Department of the Interior  
National Park Service

# NATIONAL REGISTER OF HISTORIC PLACES CONTINUATION SHEET

Section number 7

Page 16

CFN-259-1116

Hotel Randolph, Polk County, Iowa.

## PLAN OF REINFORCED CONCRETE COLUMNS

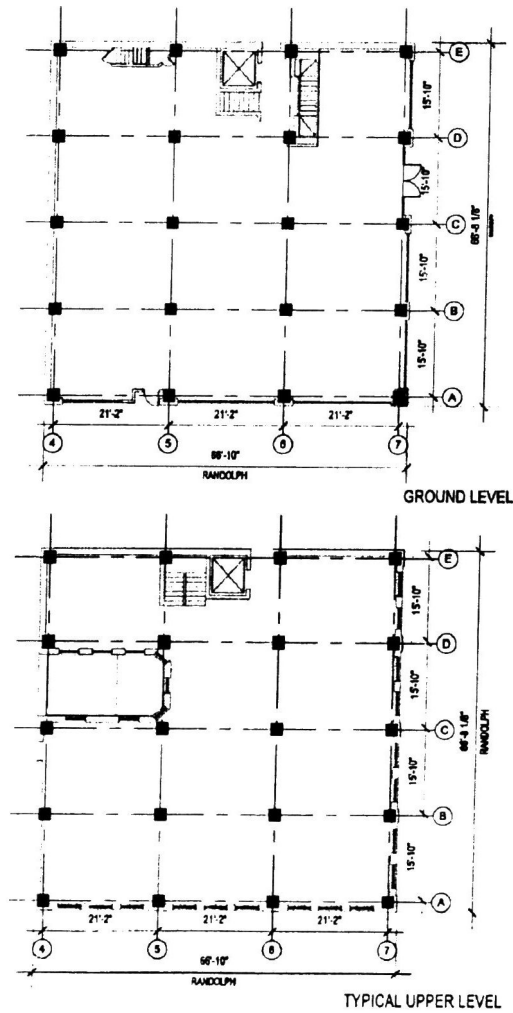

The black squares indicate the placement of reinforced concrete columns in the Hotel Randolph.

Source: Substance Architecture Interiors Design, 2008.



United States Department of the Interior  
National Park Service

# NATIONAL REGISTER OF HISTORIC PLACES CONTINUATION SHEET

Section number 7

Page 17

CFN-259-1116

Hotel Randolph, Polk County, Iowa.

## TYPICAL SECTION

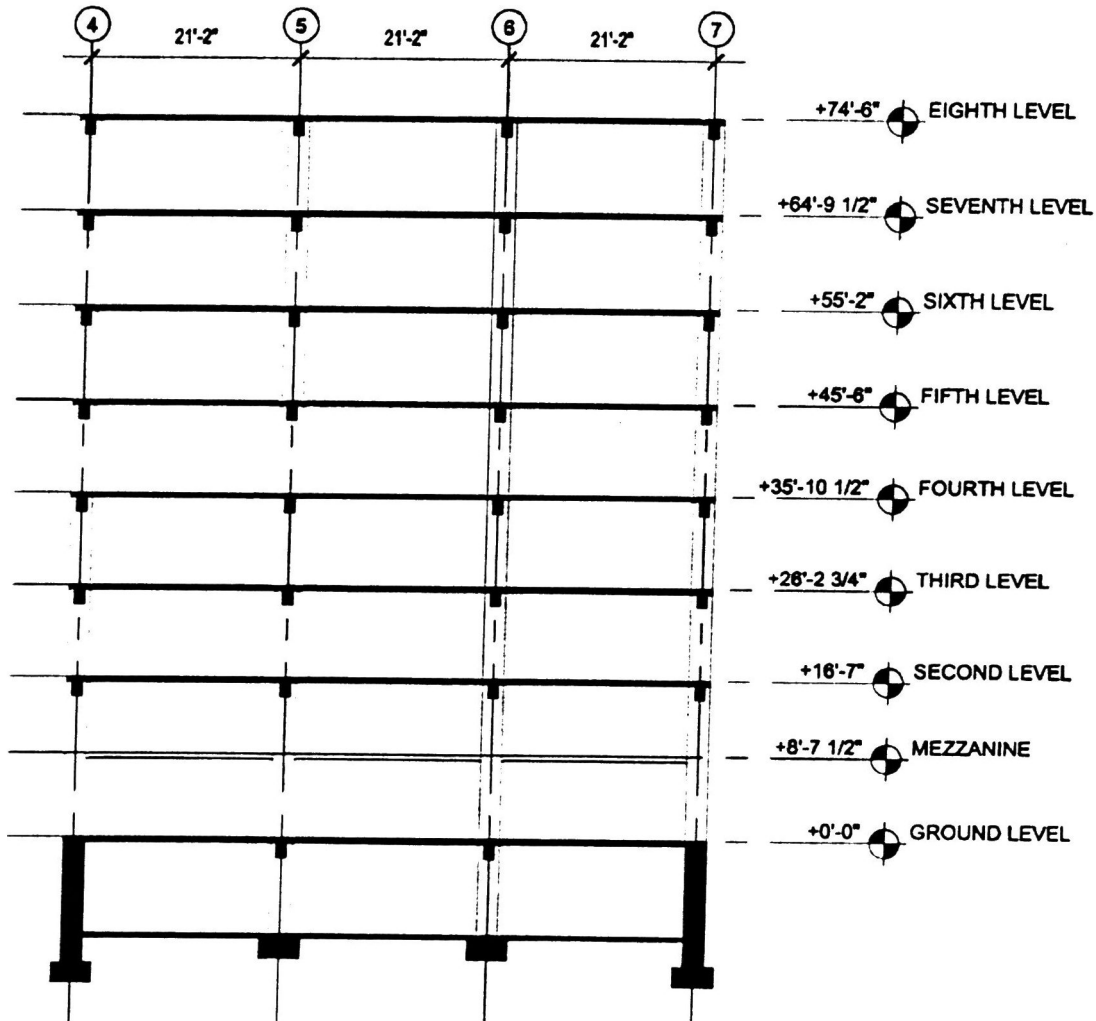

The black heavy lines indicate the placement of reinforced concrete beams and floors in the Hotel Randolph.

Source: Substance Architecture Interiors Design, 2008.

United States Department of the Interior  
National Park Service

**NATIONAL REGISTER OF HISTORIC PLACES  
CONTINUATION SHEET**

Section number 7

Page 18

CFN-259-1116

Hotel Randolph, Polk County, Iowa.

**NORTH ELEVATION**

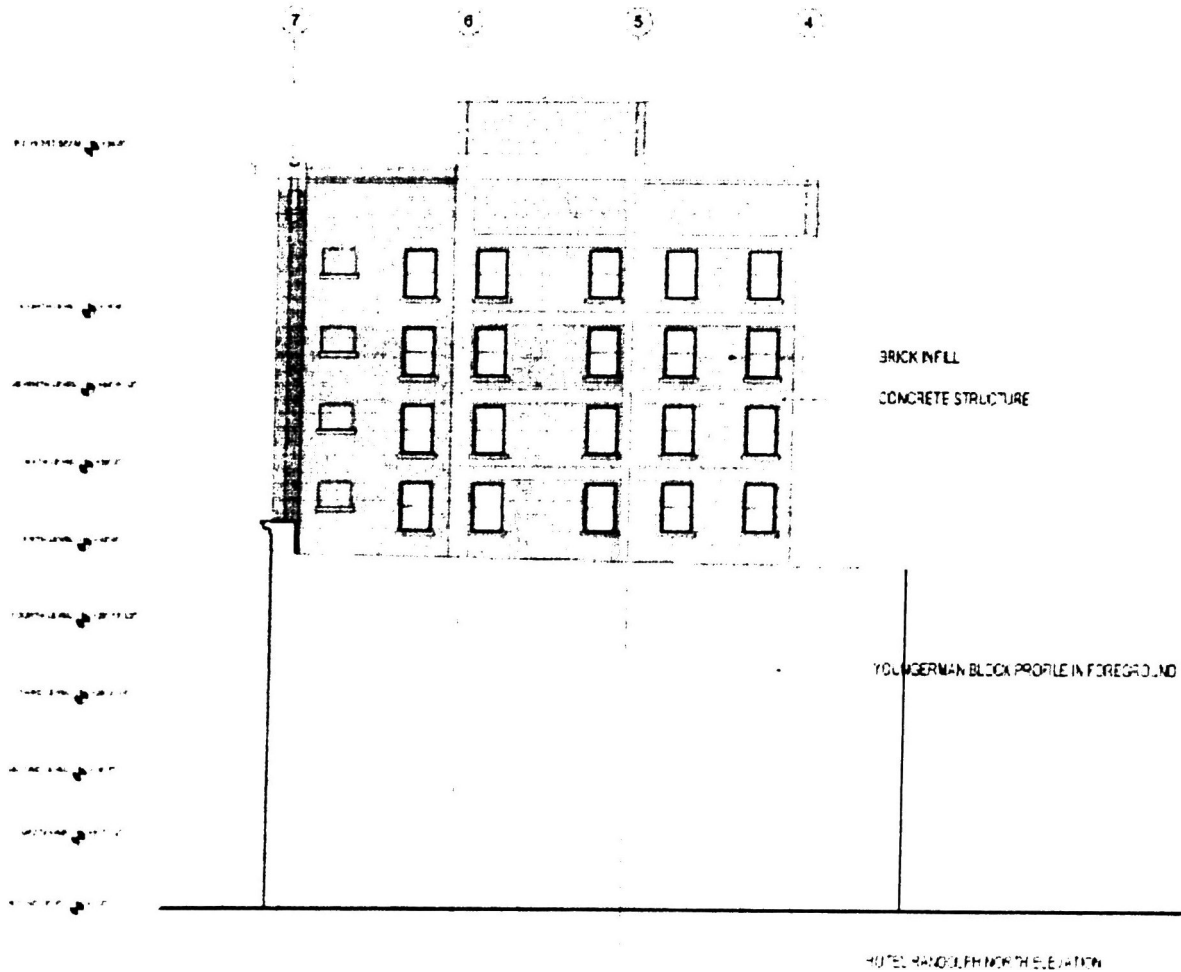

The shaded areas indicate brick infill and the white bars the network of reinforced concrete columns and beams exposed to view.

Source: Substance Architecture Interiors Design, 2008.

United States Department of the Interior  
National Park Service

# NATIONAL REGISTER OF HISTORIC PLACES CONTINUATION SHEET

Section number 7

Page 19

CFN-259-1116

Hotel Randolph, Polk County, Iowa.

## REINFORCED CONCRETE SCHEMA

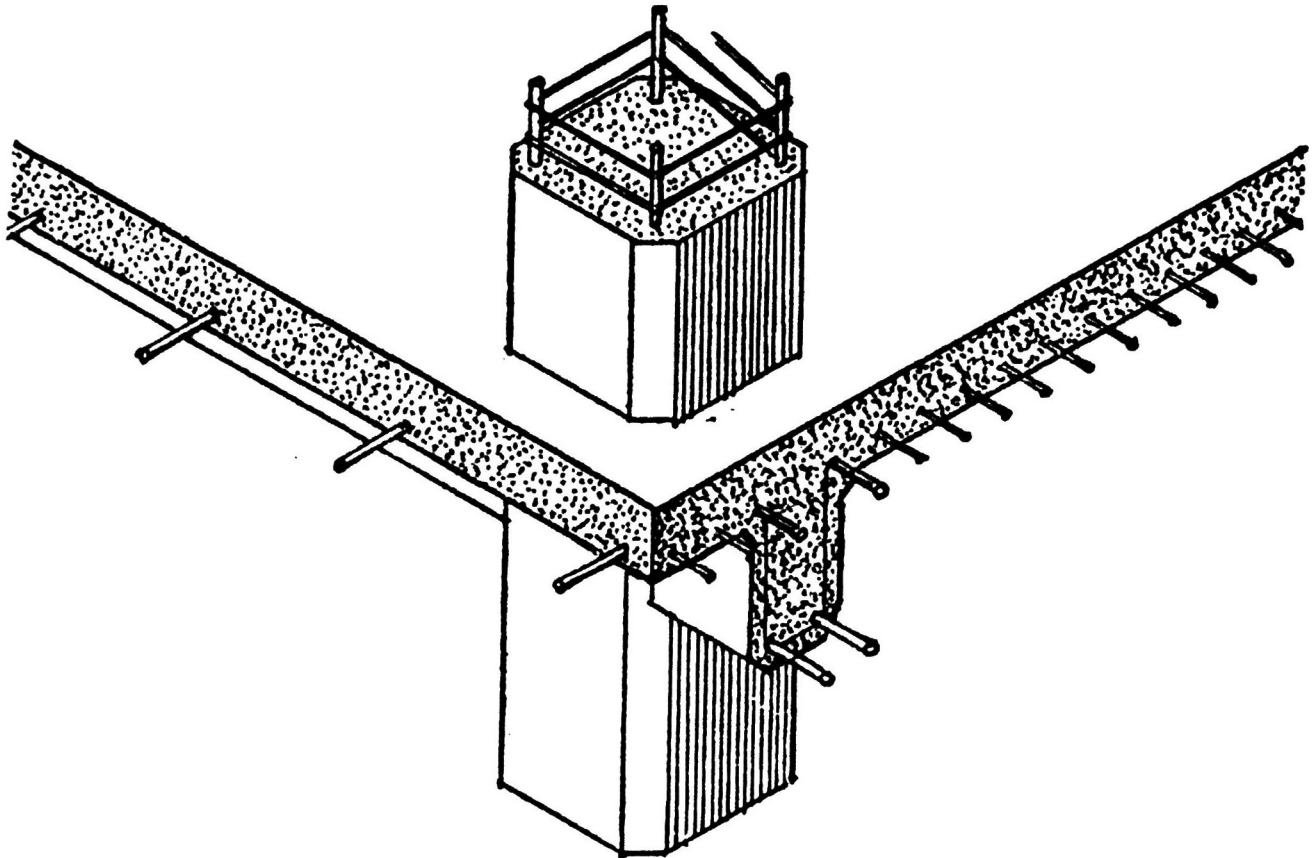

**REINFORCED CONCRETE.** *Diagram showing construction of a column, a girder, and a floor slab*

This drawing pictures reinforcing rods of steel, embedded in concrete, and shows how these rods add tensile strength to a concrete framework. Metal mesh is often added to provide additional strength to the system.

Source: Briggs, p. 269.

Hotel Randolph  
Name of Property

Polk County, Iowa  
County and State

---

## 8. Statement of Significance

### Applicable National Register Criteria

(Mark "x" on one or more lines for the criteria qualifying the property for National Register listing)

- A** Property is associated with events that have made a significant contribution to the broad patterns of our history.
- B** Property is associated with the lives of persons significant in our past.
- C** Property embodies the distinctive characteristics of a type, period, or method of construction or represents the work of a master, or possesses high artistic values, or represents a significant and distinguishable entity whose components lack individual distinction.
- D** Property has yielded, or is likely to yield, information important in prehistory or history.

### Criteria Considerations

(Mark "x" on all the lines that apply)

Property is:

- A** owned by a religious institution or used for religious purposes.
- B** removed from its original location.
- C** a birthplace or grave.
- D** a cemetery.
- E** a reconstructed building, object, or structure.
- F** a commemorative property.
- G** less than 50 years of age or achieved significance within the past 50 years.

### Areas of Significance

(Enter categories from instructions)

ENGINEERING

ARCHITECTURE

### Period of Significance

1912

### Significant Dates

1912

### Significant Person

(Complete if Criterion B is marked above)

N/A

### Cultural Affiliation

### Architect/Builder

Stevens, H. L., Co.

**Narrative Statement of Significance** - (Explain the significance of the property on one or more continuation sheets)

---

## 9. Major Bibliography References

### Bibliography

(Cite the books, articles and other sources used in preparing this form on one or more continuation sheets.)

#### Previous documentation on file (NPS):

- previous determination of individual listing (36 CFR 67) has been requested
- previously listed in the National Register
- previously determined eligible by the National Record
- designated a National Historic Landmark
- recorded by American Buildings Survey # \_\_\_\_\_
- recorded by Historic American Engineering Record # \_\_\_\_\_

#### Primary location of additional data:

- State Historical Preservation Office
  - Other State agency
  - Federal agency
  - Local government
  - University
  - Other
- Name of repository \_\_\_\_\_

United States Department of the Interior  
National Park Service

## NATIONAL REGISTER OF HISTORIC PLACES CONTINUATION SHEET

Section number 8 Page 20

CFN-259-1116

---

Hotel Randolph, Polk County, Iowa.

### SUMMARY OF SIGNIFICANCE

The Hotel Randolph is eligible for listing on the National Register of Historic Places, locally and under Criterion C, because of its structural engineering. The Randolph employed reinforced concrete for its skeletal support system and pioneered the use of this construction technology in Des Moines. The hotel's management heavily touted the new building as Des Moines' only "absolutely fireproof hotel"<sup>1</sup> and this emphasis on safety set a mandate for any hotel of any pretension in Des Moines to follow.

Further, the Hotel Randolph calls attention to the H. L. Stevens Co. of Chicago, the firm responsible for its design and construction. As a major player in hotel construction across the nation during the early 20th century, the Stevens firm's design for the Hotel Randolph helped introduce reinforced concrete technology to Des Moines. This introduction attested to the utility of this cost-effective method in the construction of fireproof edifices. The Hotel Randolph calls attention to an emerging practice within the Stevens firm—the preparation of architectural designs, which easily lent themselves to expansion. This design practice anticipated a community's potential growth and the resulting need for additional hotel space.

The period of significance, under Criterion C, for the Hotel Randolph is 1912, the year the building was completed and placed in service. The property contains one resource, the Hotel Randolph itself, which is counted as contributing and classified as a building.

### HISTORICAL BACKGROUND

The Hotel Randolph was constructed at the busy intersection of Court Avenue and Fourth Street in 1912—the year reported by *The American Contractor*, a national trade magazine, when Des Moines ranked "... first among the cities of the United States in percentage of building increase for the month of March compared with 1911.... an increase of 189 percent."<sup>2</sup> The eight-story, reinforced concrete Hotel Randolph, designed by the Chicago firm of H.L. Stevens Co., employed the latest in fire safety technology, making it the only "absolutely fireproof hotel in Des Moines."<sup>3</sup>

---

<sup>1</sup> *Des Moines City Directory*, 1913. Advertisement between pp. 230-231

<sup>2</sup> *National Democrat*, April 11, 1912..

<sup>3</sup> *Des Moines City Directory*, 1913. Advertisement between pp. 230-231.

**United States Department of the Interior**  
National Park Service

**NATIONAL REGISTER OF HISTORIC PLACES**  
**CONTINUATION SHEET**

Section number 8

Page 21

CFN-259-1116

---

Hotel Randolph, Polk County, Iowa.

On December 28, 1911, a notice of incorporation appeared in the Des Moines newspapers, marking the legal formation of the Hotel Randolph Corporation with B. Dekalb McDermott, John Arrington, and Geo. E. Cromley making up the board of directors.<sup>4</sup> The hotel project developer and property owner was James P. Hewitt, a longtime Des Moines attorney associated with the firm of Cummins, Hewitt & Wright. Hewitt also served as a district court judge for a period in and around the year he was involved in the development of the hotel (1912). Born in Pennsylvania, Hewitt came to Indianola, Iowa, where he and his wife raised four children, including Randolph, his eldest son. Hewitt named the Hotel Randolph after this boy.<sup>5</sup>

James Hewitt and the Hotel Randolph Corporation contracted with the Chicago firm of H.L. Stevens Co. for the new hotel's design. Although the Randolph appears to have been one of the firm's early hotel commissions, H.L. Stevens Co. built dozens of hotels, throughout the United States during the following years.

The Hotel Randolph (a.k.a. Randolph Hotel) celebrated a grand opening on January 24, 1912.<sup>6</sup> By April of that year the Hotel Randolph Café opened under the management of B. Dekalb McDermott, who was a member of the board of directors at the time the Hotel Randolph Corporation's charter was granted. News accounts describe the café as accessible from the street or the lobby with steps of "white Italian marble with green marble trim."<sup>7</sup> Historic images document these materials in the hotel lobby and vestiges of the marble remain in the north staircase between the basement, lobby, and mezzanine levels. The *Iowa Unionist* reported that the hotel, under the direction of Judge Hewitt, "... was built by union labor from top to bottom."<sup>8</sup>

B. Dekalb McDermott had recently served as the manager of the Hotel Colfax in Colfax, Iowa, before he signed a long-term lease on the Hotel Randolph.<sup>9</sup> According to one newspaper: "He has had wide experience as a hotel man in Boston, Minneapolis, Colfax, and Palm Beach, Fla."<sup>10</sup>

The new hotel was a huge success; and, by November of 1913, plans were well underway for the hotel's expansion. The local newspaper article explains that the addition, which, like the original building would

---

<sup>4</sup> *National Democrat*, December 20, 1911.

<sup>5</sup> *Des Moines Register and Leader*, November 23, 1911.

<sup>6</sup> *Des Moines Register and Leader*, January 25, 1912.

<sup>7</sup> *Ibid.*

<sup>8</sup> *Iowa Unionist*, November 1, 1912.

<sup>9</sup> *Des Moines Register & Leader*, November 23, 1911.

<sup>10</sup> *Ibid.*

**United States Department of the Interior**  
National Park Service

**NATIONAL REGISTER OF HISTORIC PLACES**  
**CONTINUATION SHEET**

Section number 8

Page 22

CFN-259-1116

---

Hotel Randolph, Polk County, Iowa.

be fireproof (and presumably of reinforced concrete construction), would extend north to the alley and add four stories to the height of the 1912 building. The expanded hotel was to have 300 rooms, making it the largest hotel in Des Moines.<sup>11</sup> Another newspaper published existing and proposed images of it in February 1914.<sup>12</sup> (See Continuation Sheet 7-14.)

The immediate success of the Hotel Randolph called attention to the need in Des Moines for modern hotel accommodations. A series of new hotels subsequently followed in the city, including the Northwestern Hotel at Third and Walnut (NRHP, built in 1916), the Hotel Fort Des Moines (NRHP, built in 1918), and the Savery Hotel (NRHP, built in 1919).<sup>13</sup> These new facilities eased the local pressure for hotel accommodations, and the Randolph's proposed addition never materialized. Had such an addition to the Randolph been made, it would indeed have been the largest hotel in Des Moines at a time when the demand for such a facility was high.

The fact that the Hotel Randolph was designed anticipating the possibility of a major addition is not unusual. Other H.L. Stevens Co. hotels were likewise constructed, including the St. Andrew Hotel in Minneapolis (non-extant), which was built in 1912 with a major addition made in 1916. The Jefferson Hotel in Iowa City, Iowa was built in 1913, its design configured to accommodate possible expansion - an addition that was never made.<sup>14</sup>

In the late 1940s or early 1950s, the Boss Hotel Company under its president, Edward A. Boss, purchased the Hotel Randolph and added it to its chain of hotels. At its height in the early 1950s, this company owned about three dozen hotels in Iowa, including the two major convention hotels in downtown Des Moines—the Savery Hotel and the Hotel Fort Des Moines.

### *CONSTRUCTION TECHNOLOGY*

The 8-story Hotel Randolph introduced reinforced concrete to hotel design in Des Moines and thereby set fireproof construction as a *sine qua non* for any subsequent hotel of pretension in the city.

---

<sup>11</sup> *The Des Moines Capital*, Hotel Randolph, November 14, 1913.

<sup>12</sup> *Des Moines Register*, February 15, 1914.

<sup>13</sup> National Register of Historic Places listing.

<sup>14</sup> Svendsen, Marlys. "Hotel Jefferson" Iowa Site Inventory Form 52-01487. 2000.

United States Department of the Interior  
National Park Service

**NATIONAL REGISTER OF HISTORIC PLACES  
CONTINUATION SHEET**

Section number 8

Page 23

CFN-259-1116

---

Hotel Randolph, Polk County, Iowa.

The use of concrete—an historic method of construction—experienced a revival in the United States during the early 20th century because it successfully addressed two architectural challenges of the age—how to construct tall buildings and how to make them “fireproof.” When the Hotel Randolph opened in 1912, it inaugurated a new era of hotel design in Des Moines.

Earlier construction in Des Moines had featured reinforced concrete. Constructed in 1908, the F. M. Hubbell Building on the northeast corner of Walnut and 8th Streets employed reinforced concrete for the first time in a major building project in the city. The *Des Moines Daily News* touted the new store for Chapman Bros., located in the eastern section of the F. M. Hubbell Building at 713-715 Walnut Street, as the first absolutely fireproof building in the city.<sup>15</sup>

The H.L. Stevens Co.’s design for the Hotel Randolph is significant because it introduced reinforced concrete for the first known time in hotel construction in the city. While wearing a pleasing stylistic façade, the building significance lies internally in this structural technology, which incorporated fire resistant materials in an effort to construct an “absolutely fireproof” hotel. The need for such safety was of great concern to hotel guests at this time. Local news accounts described the city’s “fire loss” in 1912 as the greatest in a decade and underscored the importance of fire safety. In 1912 alone, six major fires were reported in the downtown business section as well as “hundreds” of small fires in the downtown and residential areas.<sup>16</sup>

Fire posed a serious threat to life and property in cities across the country at the turn of the 20<sup>th</sup> century; the widespread use of highly combustible wood in congested areas resulted in the leveling of sections of many early downtown commercial centers in communities both large and small. The increasing use of brick and stone helped to ease loss due to fire, but only the development of a more effective fire-resistant building material, that of reinforced concrete, when combined with an elevated understanding about the real nature of fireproof design and construction, resulted in a significant advancement in the effort to stem loss due to fire. Like the rest of the country, Des Moines’ property losses due to fire were significant, with the year 1912 marking the city’s greatest losses in a decade. The Hotel Randolph opened its door in February of that same year—an “absolutely fireproof hotel”—against this backdrop of concern.

The loss of commercial buildings to fire had challenged property owners, city officials, and fire authorities from the nation’s earliest settlement years. Of course, as communities grew the problem was

---

<sup>15</sup> July 18, 1908.

<sup>16</sup> *Des Moines Register and Leader*, January 1, 1912.

**United States Department of the Interior**  
National Park Service

**NATIONAL REGISTER OF HISTORIC PLACES**  
**CONTINUATION SHEET**

Section number 8

Page 24

CFN-259-1116

---

Hotel Randolph, Polk County, Iowa.

compounded. The best fire departments could not stop a fire when it fed on wood and, in burgeoning towns across the nation, wood—readily available, relatively inexpensive, and viable as structural timber, exterior walling siding, and roofing shingles—was the building material of choice. Add to that the flammable nature of a building's contents and you have the makings of a true conflagration.<sup>17</sup>

Despite the availability of building materials more resistant to fire, namely brick, stone, slate and tile, their increased cost over wood impeded their widespread use. In addition, the prevailing rationalized notion that a major fire would not likely strike at home, or that the purchase of fire insurance would somehow provide adequate protection, stunted progress toward the construction of fire-resistant buildings. Further, a generally accepted definition of the term "fireproof" remained elusive for some time. Not until the early years of the 20<sup>th</sup> century was it becoming commonly understood that a "fireproof" building was one that combines a fireproof construction (steel and hollow clay tile or reinforced concrete) with non-combustible finish materials, and the proper design (with interior spaces compartmentalized).<sup>18</sup> The end result of such a construction is the containment of fire, the controlled loss of contents, and the saving of the building itself.

In the United States, fireproof buildings began to appear in the late 1700s, from which time the technology of fireproof construction began its evolution with the central driving notion being that, regardless of construction methods, in order to be considered fireproof a building's "constructive parts were of materials other than wood."<sup>19</sup> As indicated, brick and stone were sometimes utilized as construction materials more resistant to fire than wood. The often limited availability of stone proved a challenge in some areas, but brickyards became commonplace across the country making that material readily available at a relatively early time. Many found comfort in the use of brick as a construction material, but as Sara E. Wermiel points out in *The Fireproof Building*, a 19<sup>th</sup> century brick building, which used timber for floor and roof supports, "was simply a woodpile enclosed in noncombustible walls."<sup>20</sup>

Aborn House in Des Moines exemplified this construction method. Built in the mid-19<sup>th</sup> century, the brick Aborn House remained one of the city's largest hotels until the construction of the Randolph directly across the street. When the Redhead and Wellslager Block (across the street at 407-409 Court Avenue) caught fire in 1896, some occupants of Aborn House panicked and all showed alarm.

---

<sup>17</sup> Wermiel, p. 1. "Conflagration" is defined as a fire destroying groups of buildings valued at the time at \$1 million or more.

<sup>18</sup> *Cyclopedia of Fire Prevention and Insurance*. Chicago: American Technical Society, [1912], 122.

<sup>19</sup> Wermiel, 6.

<sup>20</sup> *Ibid.*

**United States Department of the Interior**  
National Park Service

**NATIONAL REGISTER OF HISTORIC PLACES**  
**CONTINUATION SHEET**

Section number 8

Page 25

CFN-259-1116

Hotel Randolph, Polk County, Iowa.

The fire burned its way to the front of the [Redhead & Wellslager] building, and burst through the windows, filling Court avenue for a block with flying embers and sparks, and making it impossible to see even a few feet for the clouds of smoke and steam. The guests at the Aborn house across the street, many of them teachers, here attending the convention, were alarmed, and many of them hurriedly dressed and rushed down stairs with their belongings. . . <sup>21</sup>

The 19<sup>th</sup> century introduction of iron as a fire-resistant construction material met with some initial success. Iron beams and girders, and cast-iron columns were employed in building construction; many of Iowa's Main Street facades dating to the mid to late 1800s utilized such columns. However, iron, while it does not burn, is highly susceptible to the extreme heat associated with fire. Under relatively low exposures to heat, iron softens and collapses under its own weight. Once a structure failed, fire spread beyond the building structure and the contents within it to neighboring structures. The development and utilization of hollow clay tile to surround and protect iron structural elements created the best method of fireproofing a building of its time.<sup>22</sup> The addition of alloys to iron in the production of steel strengthened the material, but did not eliminate its weakness under high heat. The complementary pairing of steel and clay tile, however, became the "generally accepted construction, particularly of the tall commercial buildings, the 'fireproof' structures."<sup>23</sup>

Reinforced concrete was introduced first in Europe: in England in 1854 when wire mesh was set into concrete, then in France in 1867 when Jose Moniers used wire mesh to reinforce concrete for use in garden pots, and, in pivotal developments, the 1867 use of reinforcing bars in concrete and the 1869 introduction of reinforced concrete floor slabs by Francois Hennebique.<sup>24</sup> By 1876, the first American patent for reinforced concrete for the construction of floors was issued, but until the closing years of the 19<sup>th</sup> century, few American buildings were built using the new technology.

Due to its malleable form, the potential and versatility of concrete as a building material was quickly recognized. In addition, because concrete is weak in tensile strength, but strong under compression stresses, the addition of steel or iron created a product (reinforced concrete), which offered both qualities. Shortly after the rise of fireproof clay tile, steel frame building construction was coming into use, with the growing need for office space and the skyrocketing cost of land in American cities spurring the development of tall buildings. The development of reinforced concrete as a structural building material

<sup>21</sup> *Des Moines Leader*, January 4, 1896.

<sup>22</sup> *Cyclopedia*, 128.

<sup>23</sup> *Ibid.*, 175.

<sup>24</sup> *Ibid.*, 169.

**United States Department of the Interior**  
National Park Service

**NATIONAL REGISTER OF HISTORIC PLACES**  
**CONTINUATION SHEET**

Section number 8

Page 26

CFN-259-1116

---

Hotel Randolph, Polk County, Iowa.

met two of the essential qualities needed for such buildings: a strong framework to bear the building's weight and a fire-resistant material to provide safety.

The issue of cost of construction materials had long been a deterrent to fireproof construction. However, a rise in the production of Portland cement coincided with a drop in its price resulting in an increased demand, supporting its widespread use. The *Cyclopedia of Fire Prevention and Insurance* indicates that at the time of its publication in 1912 the production of Portland cement had risen to 60,000,000 barrels annually, up from 300,000 barrels in 1890.<sup>25</sup> Further gains toward fireproof construction came as architects became more interested in employing new technologies, including using reinforced concrete. By embracing the increasingly competitive costs of fireproof construction and insisting upon their use with potential clients, the case for fireproof construction benefited significantly.<sup>26</sup> The publication also notes that the use of reinforced concrete in building construction had become "really common, although even now there are cities of some size, where there is not yet a full-fledged reinforced concrete building."<sup>27</sup>

In many ways, the Des Moines of 1912 was a reflection of the nation, particularly of Chicago whose lead it often followed. In January of that year a local newspaper revisited the events and accomplishments of the year previous: "Fire Loss in 1912 Greatest in Ten Years" headlined an article about the city's ever-present challenge. Six major fires in downtown Des Moines, as well as "hundreds" of smaller fires in the downtown and residential areas, resulted in significant property loss. With buildings constructed of combustible materials and a general lack of strictly enforced building laws the city struggled to gain a hold on property losses due to fire.<sup>28</sup> The pending increase in the use of reinforced concrete construction would soon contribute significantly to the shift to fire-resistant construction in Des Moines, and the Hotel Randolph helped lead the way.

The table on the following page lists some of the Randolph's contemporaries.

---

<sup>25</sup> *Ibid.*, 187.

<sup>26</sup> *Ibid.*, 157.

<sup>27</sup> *Ibid.*

<sup>28</sup> *Des Moines Register and Leader*, January 1, 1912.

**United States Department of the Interior**  
National Park Service

**NATIONAL REGISTER OF HISTORIC PLACES**  
**CONTINUATION SHEET**

Section number 8

Page 27

CFN-259-1116

Hotel Randolph, Polk County, Iowa.

**EARLY REINFORCED CONCRETE IN DES MOINES**  
(NONINCLUSIVE)

Name	Date of Construction	Address	Notes
F. M. Hubbell Building Chapman Bros. store in eastern section	1908	n. e. cor. 8th & Walnut Sts.	First "absolutely" fireproof bldg. in Des Moines <sup>29</sup>
Blue Line Transfer Co.	c. 1908	226 Elm Street	Advertised as the only "absolutely fireproof storage in Iowa" <sup>30</sup>
Hotel Randolph	1912	200-204 Fourth St.	H. L. Stevens, 8-story, "The only Absolutely Fireproof Hotel in Des Moines" <sup>31</sup>
Herring Motor Car Co. Building.	1912	220 10th Street	NRHP, Proudfoot, Bird & Rawson 4-story, fireproof warehouse with 2 stories added in 1913-1914 <sup>32</sup>
Hawkeye Transfer Company	1913	340 SW 5th Street	Proudfoot, Bird & Rawson, 7-story warehouse bldg. Classical Revival influence <sup>33</sup>
Hubbell Building	1913	904 Walnut Street	NRHP, Proudfoot, Bird & Rawson, concrete-clad steel frame <sup>34</sup>
Northwestern Hotel	1916	321 E. Walnut Street	NRHP, Proudfoot, Bird & Rawson, cast concrete <sup>35</sup>
Hotel Irwin	1917	Sixth & Cherry Streets	"Fireproof" <sup>36</sup>

<sup>29</sup> *Des Moines Daily News*, July 18, 1908.

<sup>30</sup> City Directory, 1913, between pp. 1620-1621.

<sup>31</sup> *Ibid.*, between pp. 530-531/

<sup>32</sup> National Register of Historic Places nomination on file at State Historical Society of Iowa, Des Moines.

<sup>33</sup> Part 1 Historic Preservation Certification Application on file at State Historical Society of Iowa, Des Moines.

<sup>34</sup> National Register of Historic Places nomination on file at State Historical Society of Iowa, Des Moines.

<sup>35</sup> National Register of Historic Places nomination on file at State Historical Society of Iowa, Des Moines.

<sup>36</sup> "Des Moines—Spokesman for the City of Des Moines," October 10, 1917.

United States Department of the Interior  
National Park Service

## NATIONAL REGISTER OF HISTORIC PLACES CONTINUATION SHEET

Section number 8

Page 28

CFN-259-1116

---

Hotel Randolph, Polk County, Iowa.

Although other reinforced concrete buildings were eventually constructed in Des Moines, the Hotel Randolph stands among the first in the city to employ this technology and the very first hotel to utilize it.

### *H. L. STEVENS CO.*

The H. L. Stevens Co. operated as a nationally recognized real estate developer, architectural firm, and construction company during the early 20th century. The firm's headquarters were at 900 (earlier 910) South Michigan Avenue, in Chicago, Illinois. The success of the Hotel Randolph (one of the firm's early commissions) established the reputation of H. L. Stevens Co. in Des Moines and placed the company in a position to gain numerous other hotel commissions in Iowa and beyond, which it did.

The Stevens firm worked extensively in Iowa and built at least eight hotels in the state, including four constructed in Des Moines, as well as many more throughout the United States. In Iowa, Stevens pioneered two construction practices of note—the use of reinforced concrete as a new construction technology and hotel designs configured for future expansion. The Hotel Randolph calls attention to both of these practices.

In Iowa and in addition to the Hotel Randolph, the firm designed the Hotel Jefferson for the Iowa City Hotel Company in 1913 and an addition for the Brown Hotel Company in Des Moines in 1918.<sup>37</sup> (The Brown Hotel served for many years as a residential hotel in Des Moines. The improvement designed by H. L. Stevens Co. was a three story addition to the top of the building and cost \$75,000 to construct. The Brown Hotel stood on the corner of 4th and Chestnut Streets before it was razed in the 1960s or 1970s. The Iowa City facility possessed six stories. The *American Contractor* published announcements of H. L. Stevens Co.'s commissions for each of these three projects.<sup>38</sup> In 1929 the firm was granted a license to practice architecture in Iowa.<sup>39</sup>

The tables on the following pages reveal that the Randolph in Des Moines was one of the Steven's earliest known hotel designs nationally and the first completed in the state of Iowa.

---

<sup>37</sup> Iowa Architects Files. State Historical Society of Iowa, Des Moines.

<sup>38</sup> *Ibid.*

<sup>39</sup> *Ibid.*

**United States Department of the Interior**  
National Park Service

**NATIONAL REGISTER OF HISTORIC PLACES**  
**CONTINUATION SHEET**

Section number 8

Page 29

CFN-259-1116

Hotel Randolph, Polk County, Iowa.

**H. L. STEVENS CO.**  
**LIST OF KNOWN WORKS IN IOWA**  
(NONINCLUSIVE)

<u>Historic Name</u>	<u>Year Built</u>	<u>Location</u>	<u>NRHP</u>	<u>Extant</u>
Hotel Randolph	1912	Des Moines	D. O. E.	Yes
Martin Hotel	1912	Sioux City	1983	Yes
Hotel Jefferson	1913	Iowa City	No	Yes
Hohenschuh Mortuary	1917	Iowa City	No	Yes
Brown Apartment Hotel (addition)	1918	Des Moines	No	No
Savery Hotel	1919	Des Moines	1998	Yes
Hotel Kirkwood	1930	Des Moines	2003	Yes
Plaza Centre Hotel	Unknown	Iowa City	No	No

**H. L. STEVENS CO.**  
**LIST OF KNOWN WORKS OUTSIDE IOWA**  
(NONINCLUSIVE)

<u>Historic Name</u>	<u>Year Built</u>	<u>Location</u>	<u>NRHP</u>	<u>Extant</u>
Leopold Hotel	1899/1910	Bellingham, WA	1982	Yes
St. Andrews Hotel	1912, 1916	Minneapolis, MN	No	No
Hotel Olympian	1919	Olympia, WA	No	Yes
Hotel Ashtabula	1920	Ashtabula, OH	1985	Yes

**United States Department of the Interior**  
National Park Service

**NATIONAL REGISTER OF HISTORIC PLACES**  
**CONTINUATION SHEET**

Section number 8

Page 30

CFN-259-1116

Hotel Randolph, Polk County, Iowa.

H. L. STEVENS CO. (CONTINUED)  
LIST OF KNOWN WORKS OUTSIDE IOWA  
(NONINCLUSIVE)

<u>Historic Name</u>	<u>Year Built</u>	<u>Location</u>	<u>NRHP</u>	<u>Extant</u>
St. Nicholas Hotel	1920, 1924, 1931	Springfield, IL	1983	Yes
Penn Alto Hotel	1921	Altoona, PA	1989	Yes
New Miami Hotel	1921	Dayton, OH	No	Unknown
The Churchill Apartments	1922	Chicago, IL	Yes	Unknown
Onesto Hotel	1925	Canton, OH	Yes	Unknown
Hotel Van Curler	1925	Schenectady, NY	1985	Yes
Bankhead Hotel	1926	Birmingham, AL	No	Yes
The Hotel Walt Whitman	1926	Camden, NJ	No	No
Hotel Bothwell	1927	Sedalia, MO	1989	Yes
Hotel Norfolk	1928	Norfolk, NE	1988	Yes
Hotel Vicksburg	1928	Vicksburg, MS	1979	Unknown
Parke Apartments	Unknown	Buffalo, NY	2007	Likely not
Burritt Hotel	Unknown	New Britain, CT	1983	Yes
Hotel Capital	Unknown	Lincoln, NE	1983	Yes

These lists show that the firm worked extensively in Des Moines and Iowa and perhaps more so there than in other cities and states across the nation. The construction of the Randolph had established the reputation of the H. L. Stevens Co. in Des Moines. Three more hotel commissions followed in the city and four more statewide in Iowa. These commissions attest to local satisfaction with the firm's work and

United States Department of the Interior  
National Park Service

## NATIONAL REGISTER OF HISTORIC PLACES CONTINUATION SHEET

Section number 8

Page 31

CFN-259-1116

---

Hotel Randolph, Polk County, Iowa.

the Stevens firm's ability to compete successfully with local architectural firms, notably Proudfoot, Bird & Rawson, for hotel commissions.

It also appears that the firm's practice of designing with the intention of future expansion became a hallmark of its work. Although the Hotel Randolph addition was never completed, the building was constructed to allow for it. In Minneapolis, the Stevens firm built the St. Andrew Hotel in 1912 and expanded it in 1916. In Iowa City, H. L. Stevens Co. built the Hotel Jefferson in 1913 in a design eyed to expansion. (It never occurred.) It is likely that further research will identify other hotels designed by Stevens, which included similar plans for expansion.

Remarkably, the story of the H. L. Stevens Co. had attracted little research to date, although the firm's opus includes buildings of note. Its prestigious hotel commissions included the Churchill Apartments, located at 1251-1259 North State Parkway in Chicago. Built in 1922, this nine-story building was designed as an apartment hotel. According Meredith Taussig of the Chicago Landmarks Commission:

It is still standing and considered noteworthy by our recent survey. It is within the "Gold Coast" National Register district.<sup>40</sup>

Taussig also notes that this building is the only H. L. Stevens & Co. design she could find in the Landmark Commission's files. (*Ibid.*) The Handbook of Illinois Society of Architects includes the Churchill Apartments as one of its "Milestones in Building Construction."

### RECOMMENDATIONS FOR ADDITIONAL RESEARCH

Further research about the H.L. Stevens Co. is recommended in an effort to provide a complete representation of the organization, services, and commissions of the firm. In respect to the Hotel Randolph specifically, one news account refers to the firm's role as designer, builder and financier.<sup>41</sup> The specific role played by the firm in the Randolph commission would likely offer a greater understanding of their impact on the growth and development of commercial areas in each of the communities where

---

<sup>40</sup> Taussig, Meredith.

<sup>41</sup> *Waterloo Reporter*, April 8, 1912.

**United States Department of the Interior**  
National Park Service

**NATIONAL REGISTER OF HISTORIC PLACES**  
**CONTINUATION SHEET**

Section number 8

Page 32

CFN-259-1116

---

Hotel Randolph, Polk County, Iowa.

hotels were built. Given the large number of those commissions, the resulting impact could be very significant.

Additional research in regard to the architects associated with the firm may lead to a larger understanding of individual contributions to American architecture. At least three individual architects are known to have been involved with designs of Iowa hotels in their association with H. L. Stevens Co., the first being H. L. Stevens himself. Stevens and C.A. Gross were responsible for the design of the Martin Hotel in Sioux City. Gross appears to have drawn the plans for the Brown Apartment Hotel in Des Moines (1912). Harry Gross designed the Hotel Savery in Des Moines for the firm and a 3-floor addition to the Brown Hotel in Des Moines.<sup>42</sup> J. A. Stevenson consulted on the Gladstone in Waterloo. (It was never built.)

Archival resources in Chicago will likely provide the best avenues for this research.

---

<sup>42</sup> *Des Moines Register*, October 27, 1918.

**United States Department of the Interior**  
National Park Service

**NATIONAL REGISTER OF HISTORIC PLACES**  
**CONTINUATION SHEET**

Section number 9

Page 33

CFN-259-1116

---

Hotel Randolph, Polk County, Iowa.

**REFERENCES**

**PRIMARY SOURCES**

Brigham, Johnson  
1911 *History of Des Moines and Polk County, Iowa*. The S. J. Clarke Publishing Company, Chicago.

Bushnell, J. P., compiler  
1889-1890 *Bushnell's Des Moines City Directory*. Des Moines Directory Co., Publishers, Volume XIII,  
Des Moines, Iowa.

*Cyclopedia of Fire Prevention and Insurance*  
1912 American Technical Society, Chicago.

Des Moines City Directories  
Various Collection of the Public Library of Des Moines.

*Des Moines Spokesman for the City of Des Moines*  
1917 Des Moines Chamber of Commerce, October 1917.

Hunt, Enos B. Jr., compiler and publisher  
c. 1912 *Illustrated Des Moines Souvenir* (a.k.a. *Des Moines Beautiful*). Bureau of Engraving, Inc., Des  
Moines, Iowa. Includes 58 photographs by A. O. Harpel's Studio.

*Iowa Architects File*; Community Programs Bureau; State Historical Society of Iowa; Des Moines, Iowa.

Polk County Assessor Office; Property Record Card.

**SECONDARY SOURCES**

Briggs, Martin S.  
1959 *Everyman's Concise Encyclopaedia of Architecture*. J. M. Dent & Sons, Ltd., London.

Condit, Carl W.  
n.d. *The Chicago School of Architecture: A History of Commercial and Public Building in the Chicago  
Area 1875-1925*. University of Chicago Press, Chicago. Circa 1960.

Condit, Carl W.  
1982 *American Building: Materials and Techniques from the Beginning of the Colonial Settlements to  
the Present*. University of Chicago Press, Chicago.

Eckhardt, Patricia A.  
1995 *Des Moines' Commercial Architecture 1876-1937; An Historic Context and Survey of Sites*.  
Prepared for and on file at the City of Des Moines and State Historical Society of Iowa.

**United States Department of the Interior**  
National Park Service

**NATIONAL REGISTER OF HISTORIC PLACES**  
**CONTINUATION SHEET**

Section number 9 Page 34

CFN-259-1116

---

Hotel Randolph, Polk County, Iowa.

Harris, Cyril M.

1998 *American Architecture: An Illustrated Encyclopedia*. W. W. Norton & Co., New York.

Iowa Press Association

1940 *Iowa Press Association's Who's Who in Iowa*. Iowa Press Association, Des Moines, Iowa.

Long, Barbara Beving

1988 *Des Moines and Polk County: Flag on the Prairie*; Windsor Publications, Inc., Des Moines, Iowa.

Maves, John

1975 "Architectural Survey of Des Moines, Iowa." Report archived at Community Programs Bureau, State Historical Society of Iowa, Des Moines, Iowa.

Nolan, Thomas, ed.

1921 *Kidder's Architects' and Builders' Handbook*. John Wiley & Sons, Inc., New York.

Raabe, Sylvia I.

1983 *Court Avenue Historic Area Study*. Report prepared for City of Des Moines, Iowa.

Shank, Wesley I.

1999 *Iowa's Historic Architects: A Biographical Dictionary*. University of Iowa Press, Iowa City, Iowa.

Saul, Charles Engineering

2008 "Randolph Hotel Structural Review Report." Des Moines, Iowa, prepared for Randolph Corner, L.L.C.

Wermiel, Sara E.

2000 *The Fireproof Building: Technology and Public Safety in the Nineteenth-Century American City*. The John Hopkins University Press, Baltimore.

Zeller, John P.

1990 "Tallest in Town." *Iowa Architect*, Volume 39, Number 4, Des Moines, Iowa.

Zingsheim, Patricia

1995 "Downtown Des Moines: Architecturally and Historically Significant Structures." Report prepared by the Community Development Department of the City of Des Moines.

## **NEWSPAPERS**

*Des Moines Leader*

1896 Fire at Redhead & Wellslager Block. January 4, 1896.

*Des Moines Register and Leader*

1911 "Work Progresses Rapidly." July 22, 1911; "Randolph Is Name Of New Hostelry." November 23, 1911.

**United States Department of the Interior**  
National Park Service

# **NATIONAL REGISTER OF HISTORIC PLACES**

## **CONTINUATION SHEET**

Section number 9

Page 35

CFN-259-1116

---

Hotel Randolph, Polk County, Iowa.

*Des Moines Register and Leader*

1912 "Fire Loss in 1912 Great In Ten Years," January 1, 1912; "New Hotel To Open Its Doors This Week,"  
January 21, 1912; "Hotel Randolph Opens Its Doors," January 25, 1912.

*Waterloo Daily Reporter*

1912 "Hotel Randolph." April 8, 1912.

### **MAPS**

Sanborn Map Company

1901, 1920, 1920-1943 (updated), 1957.

United States Geological Survey; Des Moines SE Quadrangle; 1956, photorevised 1976.

### **ORAL HISTORY**

Taussig, Meredith, with William C. Page. Taussig serves on the staff of the Chicago Landmarks Commission and shared information from that agency's files.

Hotel Randolph  
Name of Property

Polk County, Iowa  
County and State

## 10. Geographical Data

**Acreage of Property** Less than one acre

### UTM References

(Place additional UTM references on a continuation sheet.)

1 | 15 | 448 | 210 | 4603700 |

Zone Easting Northing

2 | | | | |

Zone Easting Northing

3 | | | | |

Zone Easting Northing

4 | | | | |

### Verbal Boundary Description

(Describe the boundaries of the property on a continuation sheet)

### Boundary Justification

(Explain why the boundaries were selected on a continuation sheet)

## 11. Form Prepared By

name/title William C. Page, Public Historian, Alexa McDowell, AKAY Consulting

organization Randolph Corner, L.L.C. date September 20, 2008

street & number 520 East Sheridan Avenue (Page) telephone 515-243-5740 (Page)

city or town Des Moines state Iowa zip code 50313-5017

## Additional Documentation

Submit the following items with the completed form:

### Continuation Sheets

### Maps

A **USGS map** (7.5 or 15 minute series) indicating the property's location.

A **Sketch map** for historic districts and properties having large acreage or numerous resources.

**Photographs** - Representative **black and white photographs** of the property.

**Additional items** - (Check with the SHPO or FPO for any additional items)

## Property Owner

(Complete this item at the request of SHPO or FPO.)

name Randolph Corner, L.L.C.

street & number 400 Locust Street, Suite 790 telephone 515-244-2622

city or town Des Moines state Iowa zip code 50309

**Paperwork Reduction Act Statement:** This information is being collected for applications to the National Register of Historic Places to nominate properties for listing or determine eligibility for listing, to list properties, and to amend existing listings. Response to this request is required to obtain a benefit in accordance with the National Historic Preservation act, as amended (16 U.S.C. 470 et seq.).

**Estimated Burden Statement:** Public reporting burden for this form is estimated to average 18.1 hours per response including time for reviewing instructions, gathering and maintaining data, and completing and reviewing the form. Direct comments regarding this burden estimate or any aspect of this form to the Chief, Administrative Services Division, National park Service, P.O. Box 37127, Washington, DC 20013-7127; and the Office of Management and Budget, Paperwork Reductions Projects (1024-0018), Washington, DC 20503.

**United States Department of the Interior**  
National Park Service

**NATIONAL REGISTER OF HISTORIC PLACES**  
**CONTINUATION SHEET**

Section number 9

Page 36

CFN-259-1116

---

Hotel Randolph, Polk County, Iowa.

**VERBAL BOUNDARY DESCRIPTION**

E 22F S 22F N 44F LOT 7 & S 110F LOT 8 BLK 21 FORT DES  
MOINES, LESS THAT OCCUPIED BY THE YOUNGERMAN  
BLOCK.

**BOUNDARY JUSTIFICATION**

The National Register boundary contains all land historically  
associated with this resource.

**United States Department of the Interior**  
National Park Service

**NATIONAL REGISTER OF HISTORIC PLACES**  
**CONTINUATION SHEET**

Section number 10 Page 37

CFN-259-1116

---

Hotel Randolph, Polk County, Iowa.

**LIST OF PHOTOGRAPHS**

1. Hotel Randolph  
200-204 Fourth Street  
Des Moines, IA 50309  
Looking northwest  
William C. Page, Photographer  
August 28, 2008
2. Hotel Randolph  
200-204 Fourth Street  
Des Moines, IA 50309  
Looking northeast  
William C. Page, Photographer  
August 28, 2008
3. Hotel Randolph  
200-204 Fourth Street  
Des Moines, IA 50309  
Looking southeast  
William C. Page, Photographer  
August 28, 2008
4. Hotel Randolph  
200-204 Fourth Street  
Des Moines, IA 50309  
Looking southwest  
William C. Page, Photographer  
August 28, 2008
5. Hotel Randolph  
200-204 Fourth Street  
Des Moines, IA 50309  
Looking west southwest  
William C. Page, Photographer  
August 28, 2008
6. Hotel Randolph  
200-204 Fourth Street  
Des Moines, IA 50309  
Looking west southwest  
William C. Page, Photographer  
August 28, 2008

**United States Department of the Interior**  
National Park Service

**NATIONAL REGISTER OF HISTORIC PLACES**  
**CONTINUATION SHEET**

Section number 10 Page 38

CFN-259-1116

---

Hotel Randolph, Polk County, Iowa.

7. Hotel Randolph  
200-204 Fourth Street  
Des Moines, IA 50309  
Detail of hotel room  
Isaac Bracher, Photographer  
August 28, 2008

Printed on HP Premium Plus Photo Paper, high gloss, using HP 84/85 ink.

UNITED STATES DEPARTMENT OF THE INTERIOR  
NATIONAL PARK SERVICE

NATIONAL REGISTER OF HISTORIC PLACES  
EVALUATION/RETURN SHEET

REQUESTED ACTION: NOMINATION

PROPERTY Hotel Randolph  
NAME:

MULTIPLE  
NAME:

STATE & COUNTY: IOWA, Polk

DATE RECEIVED: 4/28/09 DATE OF PENDING LIST: 5/20/09  
DATE OF 16TH DAY: 6/04/09 DATE OF 45TH DAY: 6/11/09  
DATE OF WEEKLY LIST:

REFERENCE NUMBER: 09000403

REASONS FOR REVIEW:

APPEAL: N DATA PROBLEM: N LANDSCAPE: N LESS THAN 50 YEARS: N  
OTHER: N PDIL: N PERIOD: N PROGRAM UNAPPROVED: N  
REQUEST: N SAMPLE: N SLR DRAFT: N NATIONAL: N

COMMENT WAIVER: N

ACCEPT  RETURN  REJECT 6.11.09 DATE

ABSTRACT/SUMMARY COMMENTS:

**Entered in  
The National Register  
of  
Historic Places**

RECOM./CRITERIA \_\_\_\_\_

REVIEWER \_\_\_\_\_ DISCIPLINE \_\_\_\_\_

TELEPHONE \_\_\_\_\_ DATE \_\_\_\_\_

DOCUMENTATION see attached comments Y/N see attached SLR Y/N

If a nomination is returned to the nominating authority, the nomination is no longer under consideration by the NPS.



HOTEL RANDOLPH  
POLK CO., IA  
#1



HOTEL RANDOLPH  
POLK CO., IA  
# 2



HOTEL RANDOLPH  
POLK CO., IA  
# 3



HOTEL RANDOLPH  
DOLA CO., IA  
# 4



HOTEL RANDOLPH  
POLK CO., IA  
#5



HOTEL RANDOLPH  
POLK CO., IA  
#6



HOTEL RANDOLPH  
POLK CO., IA  
#7

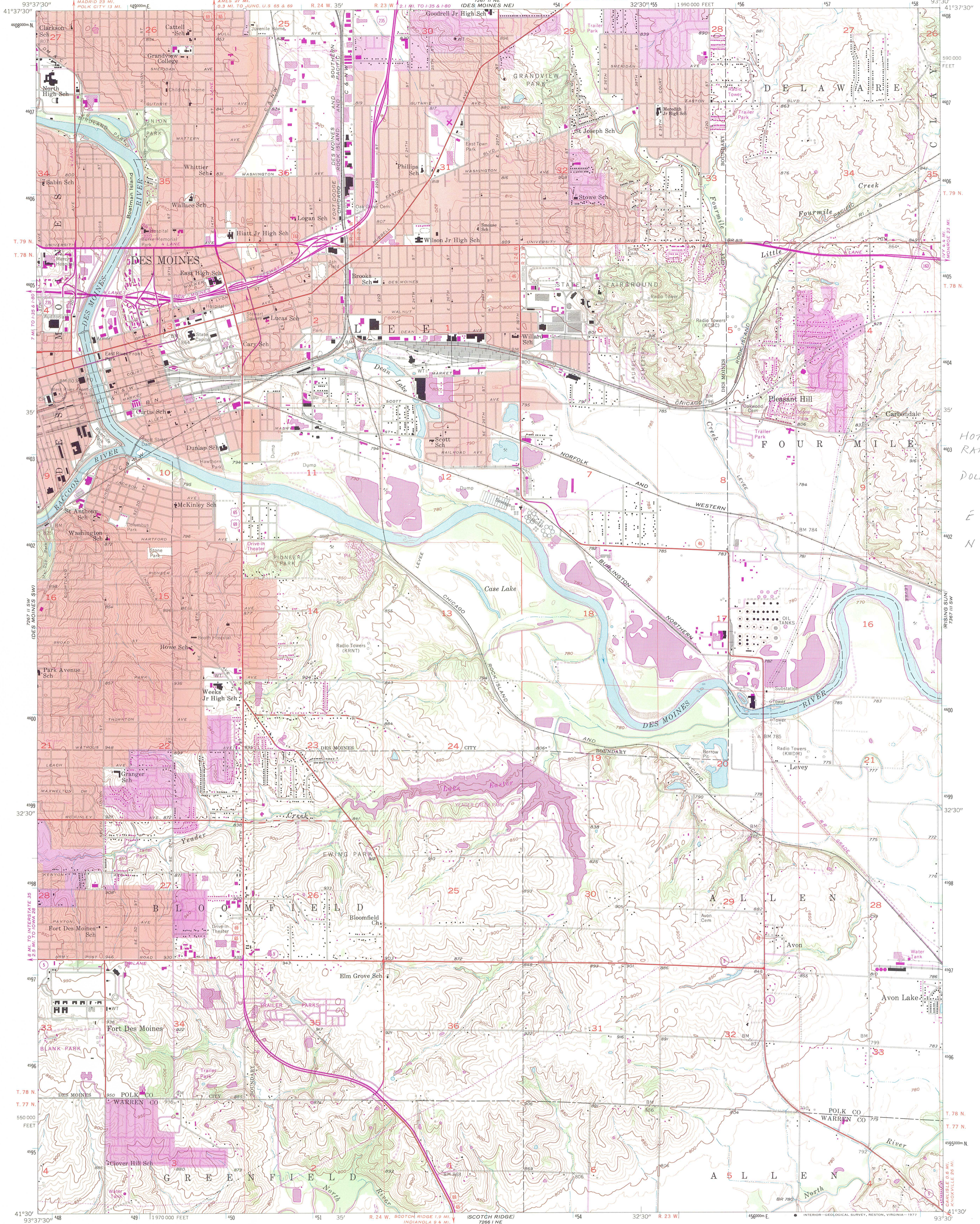

Mapped, edited, and published by the Geological Survey in cooperation with Polk County and City of Des Moines Control by USGS, USC&GS, and Iowa Geodetic Survey Topography from aerial photographs by Kelsh plotter Aerial photographs taken 1956. Field check 1956  
Polyconic projection. 1927 North American datum 10,000-foot grid based on Iowa coordinate system, south zone 1000-meter Transverse Mercator grid ticks, zone 15, shown in blue  
Red tint indicates areas in which only landmark buildings are shown  
Revisions shown in purple compiled from aerial photographs taken 1967, 1971, and 1976. This information not field checked  
Purple tint indicates extension of urban areas

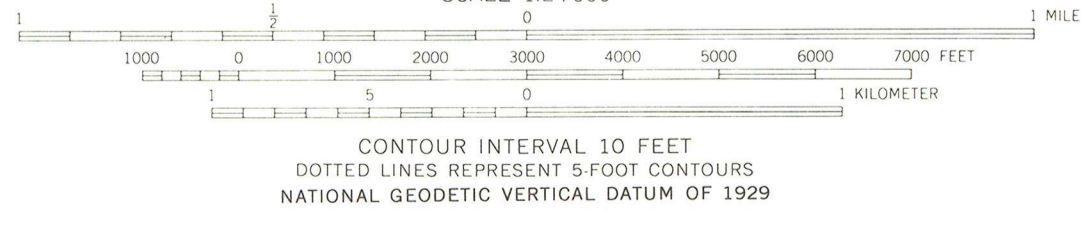
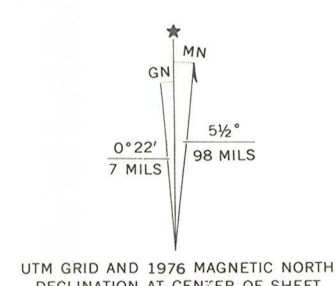

ROAD CLASSIFICATION  
Heavy-duty ——— Light-duty ———  
Medium-duty ——— Unimproved dirt - - - - -  
Interstate Route (thick red line) U.S. Route (red line) State Route (thin red line)

THIS MAP COMPLIES WITH NATIONAL MAP ACCURACY STANDARDS FOR SALE BY U.S. GEOLOGICAL SURVEY, DENVER, COLORADO 80225, OR RESTON, VIRGINIA 22092 AND BY THE IOWA GEOLOGICAL SURVEY, IOWA CITY, IOWA 52240 A FOLDER DESCRIBING TOPOGRAPHIC MAPS AND SYMBOLS IS AVAILABLE ON REQUEST

DES MOINES SE, IOWA  
SE 1/4 DES MOINES 15' QUADRANGLE  
N 4130—W 9330/7.5  
1956  
PHOTOREVISED 1967, 1971, AND 1976  
AMS 7267 II SE—SERIES V876

HOTEL  
RANDOLPH  
POLK CO., IA  
E 448210  
N 4603700

CLG NATIONAL REGISTER REVIEW

CLG Name Des Moines Date of Public Meeting 1/21/09

Property Name Hotel Randolph, 200-204 Fourth Street, Des Moines, Polk County

1. For Historic Preservation Commission:

- Recommendation of National Register eligibility
- Recommendation of National Register ineligibility

Signature Susan Holderness Date 1/21/09  
 Print Name Susan Holderness  
 Title Chair, Historic Commission

Reason(s) for recommendation:

Concur with the findings in the nomination.

2. For Chief Elected Local Official:

- Recommendation of National Register eligibility
- Recommendation of National Register ineligibility

Signature T.M. Franklin Cowrie Date 2/2/09  
 Print Name T.M. Franklin Cowrie  
 Title Mayor

Reason(s) for recommendation:

3. Professional Evaluation:

- Recommendation of National Register eligibility
- Recommendation of National Register ineligibility

Signature Karl J. Christian Date 2/9/09  
 Print Name KARL J. CHRISTIAN  
 Title HISTORIAN, HISTORIC PRESERVATION OFFICE

Reason(s) for recommendation:

April 16, 2009

J. Paul Loether, Chief  
National Park Service  
National Register of Historic Places  
1201 Eye Street, N.W.-- 8<sup>th</sup> Floor  
Washington, D.C. 20005

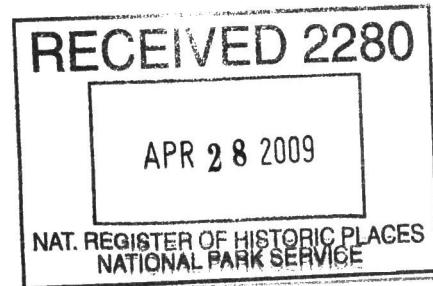

Dear Mr. Loether:

The following National Register nomination(s) are enclosed for your review and listed if acceptable.

- Hotel Randolph, 200-204 Fourth Street, Des Moines, Polk County, Iowa
- Youngerman Block, 206-208 Fourth Street, Des Moines, Polk County, Iowa
- Earle & LeBosquet Block, 407-409 Court Avenue, Des Moines, Polk County, Iowa
- Murillo Flats, 605 16<sup>th</sup> Street, Des Moines, Polk County, Iowa

Sincerely,

Elizabeth Foster Hill  
Tax Incentive Programs Manager/  
National Register Coordinator