



TOE-S626-1.4  
INSTRUCTIONS

# VS-626MTII SETUP MANUAL

Before initial operation  
read these instructions  
thoroughly and retain  
for future reference

This manual describes setting up of VS-626 MT II. For correct operation of the equipment, make accurate checking and adjustments before and after operation. If a trouble occurs during setup, refer to service manual, or contact the nearest Yaskawa office or representative.

## 1. CHECKING BEFORE OPERATION

### 1.1 Checking Power Unit and Printed Circuit Board

Be sure that the combination of the power unit and printed board should be in accordance with Table 1. If the type of any one of them is different, contact your nearest Yaskawa sales office or distributor.

Table 1 Combination of Power Unit and Printed Circuit Boards with Motor

Type		Motor Rated Output (kW) (30-minute rating)						
		5.5	7.5	11	15	18.5	22	26
Power Unit Type CIMR-MTII		5.5K	7.5K	11K	15K	18.5K	22K	26K
Controller (1PCB)		Type JPAC-C061						
Base Driver (2PCB)		Type JPAC-C062						
Motor Card (3PCB)	Foot-Mounted Type	79	71	73	74	76	77	78
	Flange-Mounted Type	70	72	73	75	76	77	78
Type JPAC-CO <input type="checkbox"/>								

### 1.2 Checking Function Selecting Connector

The selecting connectors have been set at the factory as shown in Table 2. Check to be sure that the connectors are set as tabulated when received. See Figs. 1 to 4 for positions of selecting connectors on the printed circuit boards.

Table 2 Function Selecting Connectors

	Function Name	Selection (Marked by circle)		Function Name	Selection (Marked by circle)
Con- troller	1. Speed Command Selection	Q, $\text{\textcircled{R}}$	Con- troller	6. 50/60 Hz	M, $\text{\textcircled{N}}$
				7. Slip Fre- quency	$\text{\textcircled{I}}$ , J
	2. Speed Reference Level	$\text{\textcircled{A}}$ , B $\text{\textcircled{O}}$ , P $\text{\textcircled{B}}$ , T	Base Driver	8. Decel/ Accel Time	1DS 3
				3. OS Level	$\text{\textcircled{C}}$ , $\text{\textcircled{D}}$ $\text{\textcircled{K}}$ , L
	4. UV Level	E, $\text{\textcircled{F}}$	Motor Card	1. OC Level 2. +18 V 3. -18 V	$\text{\textcircled{A}}$ , B $\text{\textcircled{C}}$ , $\text{\textcircled{D}}$ E, $\text{\textcircled{F}}$
5. Fault Indication Mode	C, $\text{\textcircled{H}}$		PWM Carrier	$\text{\textcircled{A}}$ , B	

Note: OC level is different with power unit type.

### 1.3 Checking Potentiometer Setting

The potentiometers have been adjusted to appropriate levels at the factory. The potentiometers marked by ■ in Fig. 1 are paint-locked. Be sure that the lock positions are not slid from the paint.

See Figs. 1 to 4 for the positions of the potentiometers on the printed circuit boards.

The potentiometers that are not paint-locked:

NADJ, NREV, LMADJ, SMADJ.

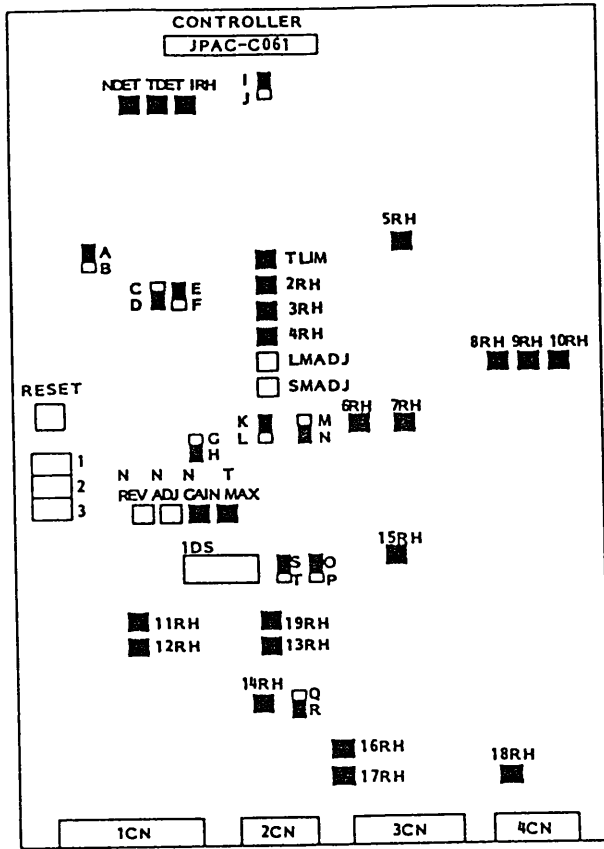

Fig. 1 Controller Parts Location

- : Potentiometers (Set at the factory)
- : Potentiometers (Adjusted by users)
- : Function Selecting Connectors

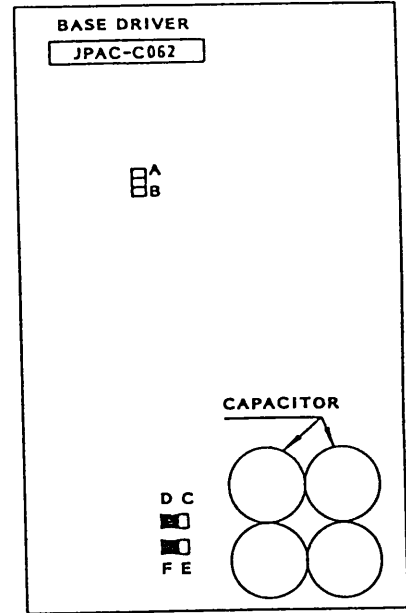

Fig. 2 Base Driver Parts Location

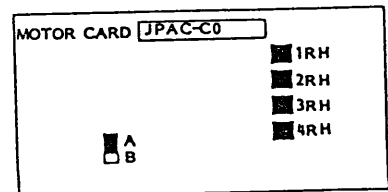

Fig. 3 Parts Location of Motor Card

## 2. CHECKING AFTER POWER ON

The following steps precede turning on the Power:

- (1) Check to be sure that there is no obstacle interrupting operations.
- (2) Before starting operation, warn the personnel nearby.

Turn on the power (circuit breaker) for VS-626MTII after securing safety around the equipment. The power pilot lamp (SOURCE) also lights when the zero-speed signal pilot lamp (ZSP), speed detector pilot lamp (NDET) light, and the ready-to-start signal is closed. (Wrong connection of the resolver signal wiring, or broken wire, can be considered if OS lights. Check the wires again.)

## 3. OPERATION

After checking, supply a running signal to operate. Gradually increasing the speed command voltage from 0 V starts the motor.

Check that the direction of motor rotation is proper. The proper direction is counter clockwise as viewed from the motor shaft end when forward running signal (FORRN) is closed and the speed command has a positive polarity is closed.

A wrong phase sequence of the power cable to the motor or of the resolver signal wire can be considered if the direction is reverse, or if the motor roars or vibrates, without rotating, during operation. Turn off the power and check the wiring.

Check that the motor smoothly accelerates and decelerates in both forward and reverse directions by changing the speed command.

At the same time check that the motor is not vibrating or emitting noise anomalously. The sound of the motor constantly audible at several thousand Hertz is caused by the control system and presents no problem.

### DANGER

A hazard of total electric shock exists. This equipment may be energized even when not in operation. The main capacitors remain charged when circuit breaker is opened. Wait 10 minutes after turning off the power, if it is needed to check inside components.

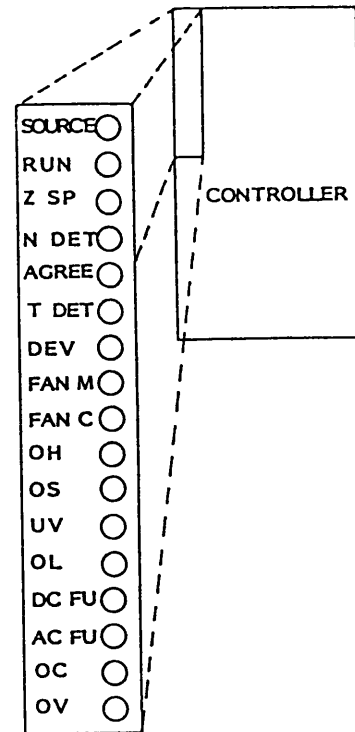

Fig. 5 LEDs

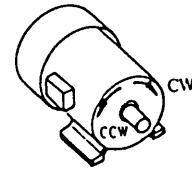

Table 3 Direction of Motor Rotation

Speed Reference Polarity	+	CCW
	-	CW

Note: Forward running signal (FORRN) is closed.

#### 4. ADJUSTMENTS

VS-626MTII has four potentiometers that can be adjusted during setup. Adjust them referring to the instructions given in the following when needed.

##### 4.1 Adjustment of Motor Speed (NADJ, NREV)

Readjust as instructed in the following when a fine adjustment of the absolute value of the spindle speed (motor speed) is required.

- (1) Rotate the motor in the forward direction, measure the speed command voltage by a voltmeter, and set to the command voltage of the desired motor speed.
- (2) Measure the speed by tachometer after the command voltage is adjusted.
- (3) Rotate NADJ clockwise if the speed does not reach the rating. Adjust NADJ until the desired speed is obtained.
- (4) Rotate NADJ counterclockwise if the speed exceeds the rating.
- (5) Run the motor in reverse direction and adjust NREV so that the rated motor speed is obtained. Turning NREV clockwise increases motor speed.

The characteristic of speed-setting scale is shown in Fig. 6.

##### 4.2 Speedometer Adjustment (SMADJ)

This is for fine adjustments of the speedometer. The meter was set to output 1 mA at the rated speed at the factory. Adjust as instructed in the following if the output deviates.

- (1) Set SMAKJ to 0 on the scale.
- (2) Set the speed command to 10 V and adjust so that the speedometer shows 100%.

Fig. 7 shows the speedometer-set scale characteristic.

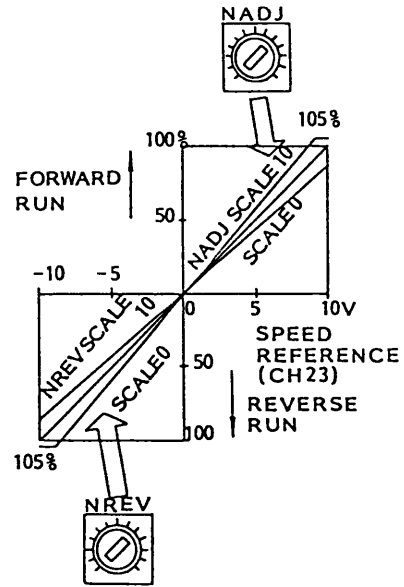

Fig. 6 Speed-Setting Characteristics

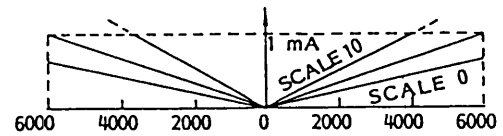
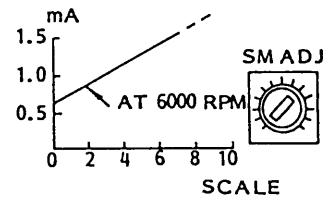

Fig. 7 Speedometer-Setting Characteristics

# VS-626MT II SETUP MANUAL

## 4.3 Loadmeter Adjustment (LMADJ)

This is for fine adjustments of the loadmeter. The meter was set to output 1 mA at 120% of the rating for 30 minutes at the factory. Adjust as instructed in the following if the output deviates.

- (1) Set LMADJ to 0 on the scale.
- (2) Set the speed command to 10 V and accelerate and decelerate exactly by switching on and off the forward running signal.

- (3) Adjust the loadmeter so that its needle indicates the full scale during rapid acceleration.

Figs. 8 and 9 show the loadmeter reading-scale characteristic and loadmeter specification respectively.

## 5. FINAL SETTING

The selecting connector M-N is for selection of 50 or 60 Hz (M for 50 Hz, N for 60 Hz). Make certain to select correct position.

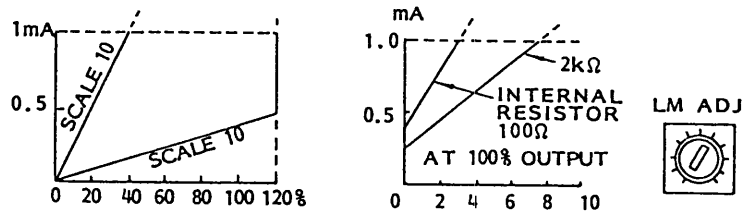

Fig. 8 Loadmeter and Setting Characteristics

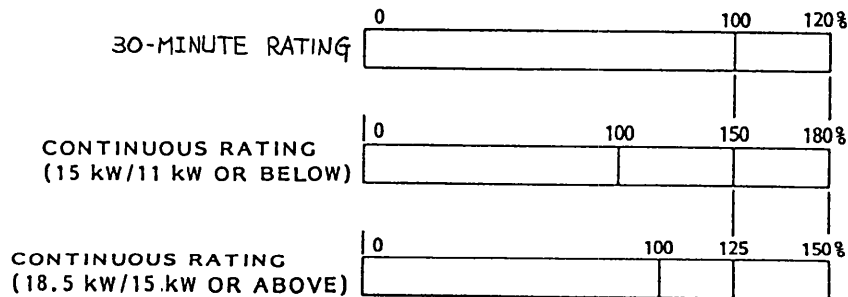

Fig. 9 Loadmeter Scale