



Instruction Bulletin
50006-360-01A
August, 1995
Replaces 50006-360-01
dated 4/93
Price: \$10.00

ALTIVAR™ 16

**Adjustable Speed AC Drive Controller
for Asynchronous Motors**



DANGER

HAZARDOUS VOLTAGE.

- Read and understand this bulletin in its entirety before installing or operating AC drive controllers. Installation, adjustment, repair and maintenance of these drive controllers must be performed by qualified personnel.
- Disconnect all power before servicing drive controller. WAIT ONE MINUTE until bus capacitors discharge, then measure bus capacitor voltage between J9+ and J8- terminals to verify DC voltage is less than 45 V. See page 6.
- DO NOT short across capacitors or touch unshielded components or terminal strip screw connections with voltage present.
- Install all covers before applying power or starting and stopping the drive controller.
- User is responsible for conforming to all applicable code requirements with respect to grounding all equipment. For more information on grounding, see page 9.
- Many parts in this drive controller, including printed wiring boards, operate at line voltage. DO NOT TOUCH. Use only electrically insulated tools while making adjustments.

Before installing drive controller:

- Disconnect all power.
- Place a "DO NOT TURN ON" label on the drive controller disconnect.
- Lock disconnect in open position.

Failure to observe these precautions will cause burn or shock, resulting in death or severe personal injury.

Note: On earlier models, the DC bus terminals, designated J8- and J9+ in the Bus Voltage Measurement Procedure, are designated as follows:

Catalog No.	J8-	J9+
ATV16U09M2	J211	J212
ATV16U18M2		
ATV16U29M2	J104	J105
ATV16U18N4		
ATV16U29N4		
ATV16U41M2	J110	J112
ATV16U41N4		
ATV16U54N4		
ATV16U72N4		

TRADEMARKS

ALTIVAR™ is a trademark of Square D Company.

COPYRIGHT NOTICE

© 1993 Schneider S.A. All rights reserved. This document may not be copied in whole or in part, or transferred to any other media, without the written permission of Schneider S.A.

PLEASE NOTE

Electrical equipment should be serviced only by qualified electrical maintenance personnel, and this document should not be viewed as sufficient instruction for those who are not otherwise qualified to operate, service or maintain the equipment discussed. Although reasonable care has been taken to provide accurate and authoritative information in this document, no responsibility is assumed by Schneider S.A. for any consequences arising out of the use of this material.

Table of Contents

50006-360-01A
August, 1995

List of Topics

RECEIVING AND PRELIMINARY INSPECTION	1
Storing and Shipping.....	1
Catalog Number Identification.....	1
TECHNICAL CHARACTERISTICS	2
SPECIFICATIONS	3
DIMENSIONS.....	4
INSTALLATION PRECAUTIONS	5
MEASURING BUS CAPACITOR VOLTAGE	5
Bus Voltage Measurement Procedure.....	6
WIRING	7
General Wiring Practices.....	7
Branch Circuit Connections.....	8
Output Wiring Precautions	8
Grounding	9
Terminal Strip Characteristics	10
Wiring Diagram	12
DRIVE CONTROLLER SET UP	12
Factory Settings	12
Switch Settings.....	14
2-WIRE TRANSITIONAL CONTROL	16
DIRECTION OF ROTATION	17
THERMAL OVERLOAD PROTECTION OF THE MOTOR	17
AVAILABLE TORQUE.....	18
PREVENTIVE MAINTENANCE.....	19
DIAGNOSTICS.....	20
Fault Storage.....	20
ADDITIONAL DOCUMENTATION	21

List of Figures

Figure 1	Catalog Numbers for ALTIVAR 16 Drive Controllers	1
Figure 2	Dimensions.....	4
Figure 3	IP30 Installation.....	5
Figure 4	Mounting Precautions.....	5
Figure 5	Measuring Bus Capacitor Voltage.....	6
Figure 6	Wiring Terminals	7
Figure 7	Grounding Multiple Drive Controllers	10
Figure 8	ALTIVAR 16 Drive Controller Terminal Strips	10
Figure 9	ALTIVAR 16 Drive Controller Wiring Diagram.....	12
Figure 10	Drive Controller Configuration Switches.....	14
Figure 11	Configuring Switch 1	15
Figure 12	Configuring Switch 2	15
Figure 13	2-Wire Transitional Control.....	16
Figure 14	Standard 2-Wire Control.....	16
Figure 15	Direction of Rotation.....	17
Figure 16	Typical ALTIVAR 16 Drive Controller Torque Characteristics.....	18
Figure 17	LED States	20

List of Tables

Table 1	Technical Characteristics: ATV16***M2: 208 V \pm 10% and 240 V \pm 10%, 50/60 Hz.....	2
Table 2	Technical Characteristics: ATV16***N4: 400 V \pm 15% and 460 V \pm 15%, 50/60 Hz	2
Table 3	Specifications	3
Table 4	Terminal Strip Characteristics	11
Table 5	ALTIVAR 16 Drive Controller Factory Settings	12
Table 6	Documentation for ALTIVAR 16 Drive Controller Products.....	21

RECEIVING AND PRELIMINARY INSPECTION

Before installing the ALTIVAR 16 drive controller, read this manual and observe all precautions:

- Before removing the drive controller from its packing material, verify it is not damaged from shipping. Any damage to the packing carton usually indicates improper handling. If any damage is found, notify the carrier and your Square D representative.
- After removing the drive controller from its packaging, visually inspect the exterior for shipping damage.
- Verify that the drive controller nameplate and label conform to the packing slip and corresponding purchase order. Drive controller catalog numbers are explained below.

 CAUTION
DAMAGED EQUIPMENT HAZARD. Do not operate or install any drive controller that appears damaged. Failure to observe this precaution can result in personal injury or equipment damage.

Storing and Shipping

If the drive controller is not being immediately installed, store it in a clean, dry area where the ambient temperature is between -25 and +70 °C (-13 to +158 °F).

If the drive controller must be shipped to another location, use the original shipping material and carton to protect the drive controller.

Catalog Number Identification

Figure 1 shows how the ALTIVAR 16 drive controller catalog numbers are structured.

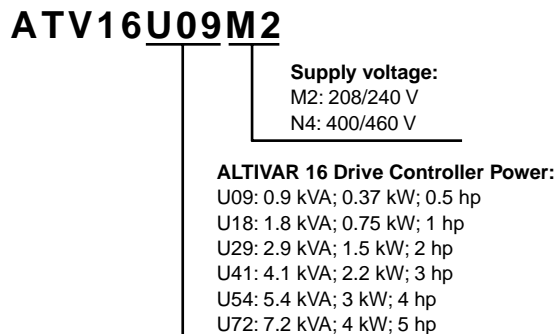

Figure 1 Catalog Numbers for ALTIVAR 16 Drive Controllers

TECHNICAL CHARACTERISTICS

Table 1 Technical Characteristics:
ATV16*M2: 208 V ± 10% and 240 V ± 10%, 50/60 Hz**

Drive Controller Catalog Number	Motor Power		Input Line Current ^[1]				Rated Output Current	Transient Output Current ^[2]	Total Dissipated Power @ Rated Load	Short Circuit Rating	Maximum Fuse ^[3]
			Single Phase		Three Phase						
ATV16****	kW	hp	208 V	240 V	208 V	240 V	A	A	W	A rms sym.	FU1,FU2,FU3
U09M2	0.37	0.5	4.9	4.2	—	—	2.1	3.2	22	1,000	KTK-R-6
U18M2	0.75	1	7.7	7.0	—	—	4	5.4	35	1,000	KTK-R-10
U29M2	1.5	2	17.1	15.9	9.5	8.7	7.1	10	55	5,000	1ø: KTK-R-20 3ø: KTK-R-15
U41M2	2.2	3	24.1	21.9	13.1	11.9	10	14	65	5,000	1ø: KTK-R-30 3ø: KTK-R-20

^[1] Values correspond to the amount absorbed by drive controllers supplied by mains with fault capacity equal to short-circuit rating indicated in table and under nominal conditions of load and speed of the associated motor.

^[2] For 60 seconds.

^[3] Bussmann or equivalent.

Table 2 Technical Characteristics:
ATV16*N4: 400 V ± 15% and 460 V ± 15%, 50/60 Hz**

Drive Controller Catalog Number	Motor Power		Input Line Current ^[1]		Rated Output Current	Transient Output Current ^[2]	Total Dissipated Power @ Rated Load	Short Circuit Rating	Maximum Fuse ^[3]
	400 V 50 Hz	460 V 60 Hz	Three Phase						
ATV16****	kW	hp	400 V	460 V	A	A	W	A rms sym.	FU1,FU2,FU3
U18N4	0.75	1	3.2	2.8	2.3	3.1	35	5,000	KTK-R-5
U29N4	1.5	2	5.7	4.9	4.1	5.5	50	5,000	KTK-R-10
U41N4	2.2	3	7.5	6.6	5.8	7.9	70	5,000	KTK-R-15
U54N4	3	—	9.6	—	7.8	11	100	5,000	KTK-R-20
U72N4	4	5	11.3	9.9	10.5	14.2	135	5,000	KTK-R-25

^[1] Values correspond to the amount absorbed by drive controllers supplied by mains with fault capacity equal to short-circuit rating indicated in table and under nominal conditions of load and speed of the associated motor.

^[2] For 60 seconds.

^[3] Bussmann or equivalent.

SPECIFICATIONS

Table 3 Specifications

Input Voltage	ATV16***M2: 208 V \pm 10% and 240 V \pm 10% ATV16***N4: 400 V \pm 15% and 460 V \pm 15%
Input Frequency	50/60 Hz \pm 2 Hz
Input Phases	ATV16U09M2, U18M2: 1 ATV16U29M2, U41M2: 1 or 3 ATV16***N4: 3
Output Voltage	Maximum voltage equal to input voltage
Output Frequency	0.1 to 50/60 Hz
Output Phases	3
Transient Overtorque	150% of rated motor torque (\pm 5% from 5 to 50/60 Hz)
Accel/Decel	3 s from 0 to 50/60 Hz (automatic ramp adaptation when transient torque capabilities are exceeded)
Control Power	24 VDC +25%, -50%
Speed Reference	0-10 V, 0-20 mA, 4-20 mA
Run Signal	2 Inputs: FW (Forward) and RV (Reverse)
Braking	Automatic DC injection braking for 0.5 s if frequency drops below 0.1 Hz
Display	Green LED indicates drive controller supply is on Red LED indicates drive controller fault
Drive Controller Protection	Overvoltage and undervoltage protection Protection against input phase loss (ATV16***N4 only) Protection against short circuits between output phases, between output phase and ground Protection against short circuits in internal control supplies (+10 V, +24 V) Overload and overtemperature protection
Motor Protection	Thermal I ² t if motor FLA = 0.9 drive controller I _n (rated output current) (from 25/30 to 50/60 Hz)
Temperature	Operation: +32 to +104 °F (0 to +40 °C) with top plate installed +32 to +122 °F (0 to +50 °C) without top plate Storage: -13 to +158 °F (-25 to +70 °C)
Humidity	95% maximum, non-condensing and without dripping (provide heating system if there is condensation)
Altitude	Up to 3,300 ft (1,000 m) without derating; derate by 3% for each additional 3,300 ft (1,000 m)
Enclosure	IP30 [1]
Pollution	Protect the drive controller against dust, corrosive gases and splashing liquid [1]
Standards	UL, CSA, IEC, VDE UL Listed as a Class 10 Overload Protective Device

[1] Drive controller electrical creepages are designed for use in a pollution Degree 2 environment per NEMA ICS-111A and IEC 664.

DIMENSIONS

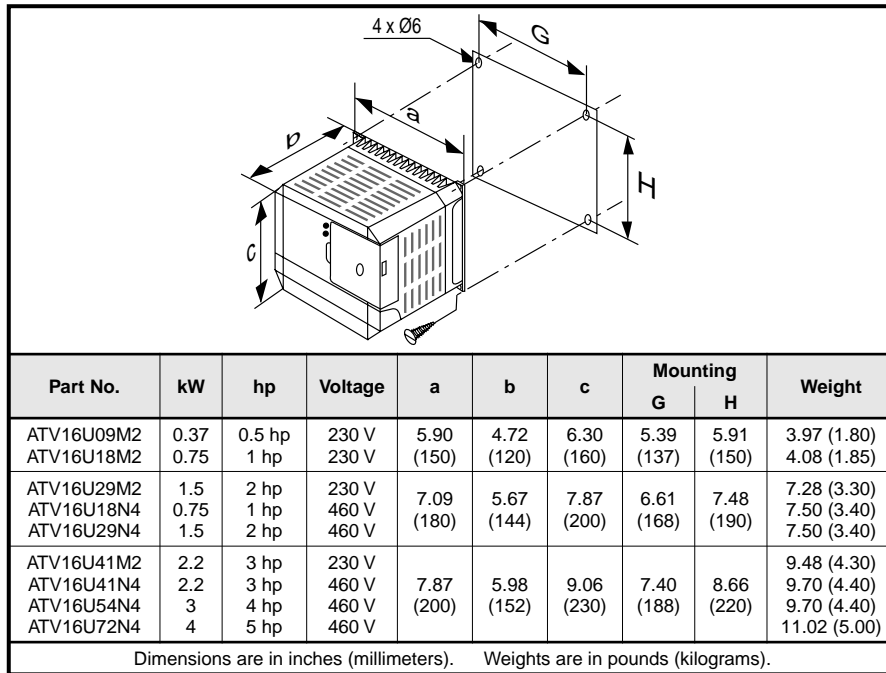

Figure 2 **Dimensions**

INSTALLATION PRECAUTIONS

- ❑ The ATV16 drive controller is IP30. When installing in an enclosure, remove the plastic plate from the top of the drive controller.
- ❑ Figure 3 shows the minimum clearances required around the drive controller for unobstructed airflow; $D \geq 4$ in (100 mm), $d \geq 2$ in (50 mm). These clearances should not be used as minimum enclosure size for proper thermal dissipation.
- ❑ Mount the drive controller vertically, as shown in Figure 4. Avoid placing near any heat sources.

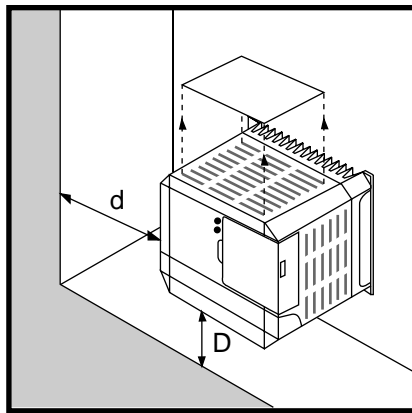

Figure 3 IP30 Installation

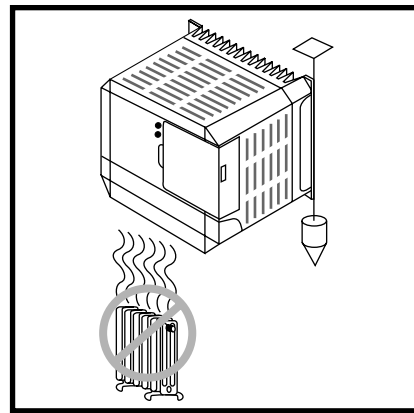

Figure 4 Mounting Precautions

MEASURING BUS CAPACITOR VOLTAGE

DC bus capacitor voltage is measured between the J9+ and J8- terminals of the drive controller. The DC bus capacitors are discharged when input power is removed from the drive controller. To ensure the capacitors are fully discharged, always disconnect all power, wait 1 minute, then test with a DC voltmeter (1000 VDC scale) before wiring, troubleshooting or working inside the drive controller. If no reading is shown on the voltmeter, reduce scale and test again.

The J9+ and J8- terminals are located on the power board, in the general area shown in Figure 5. To measure the bus capacitor voltage, follow the Bus Voltage Measurement Procedure.

⚠ DANGER

HAZARDOUS VOLTAGE.

- **Read and understand Bus Voltage Measurement Procedure before performing procedure. Measurement of bus capacitor voltage must be performed by qualified personnel.**
- **DO NOT short across capacitors or touch unshielded components or terminal strip screw connections with voltage present.**
- **Many parts in this drive controller, including printed wiring boards, operate at line voltage. DO NOT TOUCH. Use only electrically insulated tools.**

Failure to observe these precautions will cause burn or shock, resulting in death or severe personal injury.

Bus Voltage Measurement Procedure

1. Disconnect all power from the drive controller.
2. Wait 1 minute to allow the DC bus to discharge.
3. Remove all covers.
4. Set the voltmeter to the 1000 VDC scale. Measure the bus capacitor voltage between the J9+ and J8- terminals to verify the DC voltage is less than 45 V. **Do not short across capacitor terminals with voltage present!**
5. Contact your local Square D representative if the bus capacitors are not fully discharged—**do not operate the drive controller.**
6. Replace all covers.

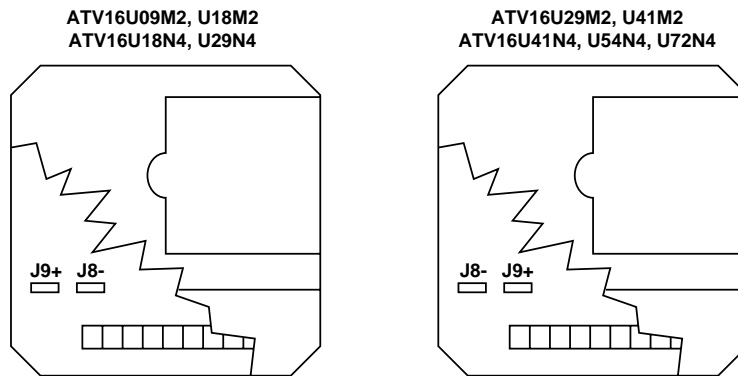

Figure 5 Measuring Bus Capacitor Voltage

WIRING

Figure 6 shows the location of the drive controller wiring terminals.

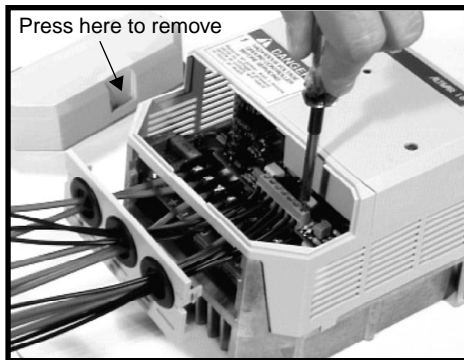

Figure 6 Wiring Terminals

General Wiring Practices

Good wiring practice requires the separation of control circuit wiring from all power (line) wiring. Power wiring to the motor must have the maximum possible separation from all other power wiring, whether from the same drive controller or other drive controllers; **do not run in the same conduit**. This separation reduces the possibility of coupling electrical transients from power circuits into control circuits or from motor power wiring into other power circuits.

CAUTION

EQUIPMENT DAMAGE HAZARD.

Follow wiring practices described in this document in addition to those already required by the National Electrical Code and local electrical codes.

Failure to observe this precaution can result in personal injury or equipment damage.

Follow the practices below when wiring ALTIVAR 16 drive controllers:

- Use metallic conduit for all drive controller wiring. Do not run control and power wiring in the same conduit.

Note: The plastic wire entry plate is not suitable for direct conduit attachment. User must supply mechanical support and bonding means. *In this case, the metal conduit Entry Plate Kit, VY1A16201 (for ATV16U09M2, U18M2), VY1A16202 (for ATV16U29M2, U18N4, U29N4) or VY1A16203 (for ATV16U41M2, U41N4, U54N4, or U72N4) can be ordered.*

- Metallic conduits carrying power wiring or low-level control wiring must be separated by at least 3 in (7.62 cm).

- ❑ Non-metallic conduits or cable trays used to carry power wiring must be separated from metallic conduit carrying low-level control wiring by at least 12 in (30.5 cm).
- ❑ Whenever power and control wiring cross, the metallic conduits and non-metallic conduits or trays must cross at right angles.

Branch Circuit Connections

All branch circuit components and equipment (such as transformers, feeder cables, disconnect devices and protective devices) must be rated for the maximum input current of the ALTIVAR 16 drive controller, not the motor full load current. The drive controller input current is stamped on the nameplate.

 WARNING
IMPROPERLY COORDINATED DEVICES WILL MISOPERATE.
<ul style="list-style-type: none">• Branch circuit components and equipment must be rated for the maximum drive controller rated current.• If the system short circuit capacity (current) available at the input line terminals is larger than the nameplate rating, higher-than-rated line currents will be drawn from the input line and equipment misoperation may occur.
Failure to observe these precautions can result in death, severe personal injury or equipment damage.

In some installations, conducted emissions to the line from the drive controller must be attenuated to prevent interference with telecommunication, radio and sensitive electronic equipment. In these instances, attenuating filters may be required. Consult factory for selection and application of these filters.

Output Wiring Precautions

 WARNING
DRIVE CONTROLLER DAMAGE.
Drive controller will be damaged if input line voltage is applied to output terminals (U/T1, V/T2, W/T3). Check power connections before energizing drive controller.
Failure to observe this precaution can result in death, severe personal injury or equipment damage.

The drive controller is sensitive to the amount of capacitance (either phase-to-phase or phase-to-ground) present on the output power conductors. If excessive capacitance is present, the drive controller may trip on overcurrent.

Follow the guidelines below when selecting output cable:

- Cable type: the cable selected must have a low capacitance phase-to-phase and to ground. Do not use mineral-impregnated cable because it has a very high capacitance. Immersion of cables in water increases capacitance.
- Cable length: the longer the cable, the greater the capacitance. Cable lengths greater than 320 ft (100 m) may cause problems.
- Proximity to other output cables: because of the high frequency switching and increased capacitance, the drive controller may fault under some conditions.
- Do not use lightning arrestors on output of drive controller.

For installations where cable capacitances may be a problem, install an inductor between the drive controller and the motor. Maximum cable length in this case is 490 ft (150 m).

A minimum inductance is needed to protect the drive controller output from short circuits. Provide at least 19.7 in (50 cm) of cable at drive controller output (U/T1, V/T2, W/T3).

 CAUTION
DRIVE CONTROLLER SWITCH FAILURE. For proper drive controller electronic short circuit protection, certain values of inductance may be required in the output power wiring. Inductance can be supplied by the power wiring or auxiliary inductors. Failure to observe this precaution can result in equipment damage.

Grounding

For safe, dependable operation, drive controllers must be grounded according to National Electrical Code and all local codes. To ground the drive controller:

- Connect a copper wire from the grounding terminal to the power system ground conductor. Wire size is determined by the drive controller size (see page 11), the National Electrical Code and local electrical codes.
- Verify that resistance to ground is one ohm or less. Improper grounding causes intermittent and unreliable operation.

 DANGER
HAZARDOUS VOLTAGE. <ul style="list-style-type: none">• Ground equipment using connection provided. Drive controller panel must be properly grounded before applying power.• Do not use metallic conduits as a ground conductor. Failure to observe these precautions will cause burn or shock, resulting in death or severe personal injury.

Multiple drive controllers must be grounded as shown in Figure 7. Do not loop or series the ground cables.

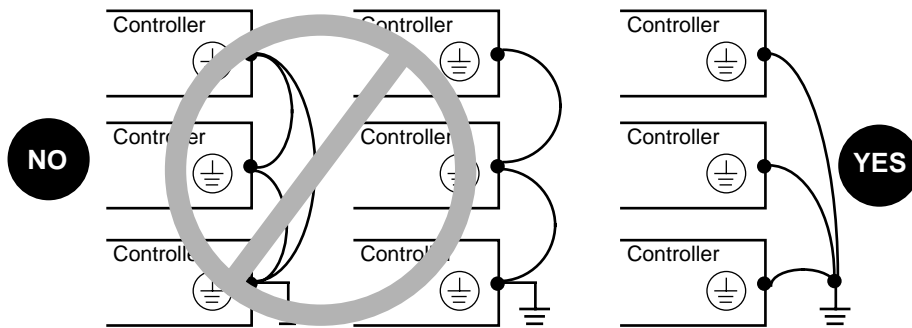

Figure 7 Grounding Multiple Drive Controllers

Terminal Strip Characteristics

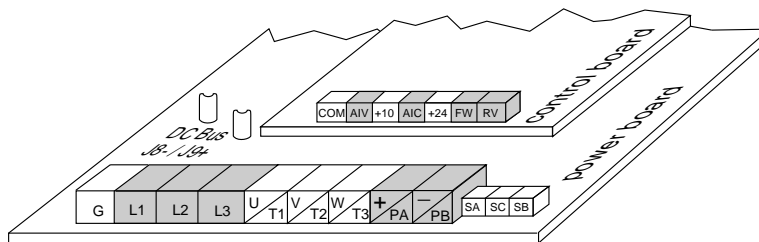

Figure 8 ALTIVAR 16 Drive Controller Terminal Strips

Table 4 Terminal Strip Characteristics

Terminal Reference ATV16****		Function		Characteristics	Max. Wire Size AWG (mm ²)	Torque lb-in (N•m)
U09M2 U18M2	U29M2 U41M2 U**N4	Ground			12 (2.5)	12 (1.4)
L1 L2	L1 L2 L3	Input power		208 V ± 10% and 240 V ± 10% 400 V ± 15% and 460 V ± 15%	12 (2.5)	12 (1.4)
U/T1 V/T2 W/T3	U/T1 V/T2 W/T3	Output connections to motor		M2: 230 V/50 Hz N4: 400 V/50 Hz 230 V/60 Hz 460 V/60 Hz	12 (2.5)	12 (1.4)
+ -	PA PB	ATV16U09M2 ATV16U18M2 Connection for dynamic braking module	ATV16U29M2 ATV16U41M2 ATV16U**N4 Connection for dynamic braking resistance	See dynamic braking manual For ATV16***M2: R ≥ 47 Ω For ATV16***N4: R ≥ 68 Ω	12 (2.5)	12 (1.4)
SA SC SB	SA SC SB	N.C. Contact [1] Common N.O. Contact	Fault relay outputs	Minimum: 10 mA, 24 VDC [2] Maximum: inductive charge of 1.5 A, 250 V 2.5 A, 30 VDC	14 (1.5)	3.5 (0.4)
J9+ J8-	J9+ J8-	Filtered DC voltage [3]		265 V < V < 370 V 480 V < V < 745 V	—	—
COM	COM	Common for speed reference inputs and control inputs		0 V	14 (1.5)	3.5 (0.4)
AIV	AIV	Speed reference voltage input		0-10 V, Impedance= 30 kΩ	14 (1.5)	3.5 (0.4)
+10	+10	Reference input supply		10 VDC, 10 mA maximum 1 kΩ < R < 10 kΩ	14 (1.5)	3.5 (0.4)
AIC	AIC	Speed reference current input		0-20 mA, 4-20 mA, Impedance = 250Ω	14 (1.5)	3.5 (0.4)
+24	+24	Control inputs supply		24 VDC (from 20 to 30 VDC)	14 (1.5)	3.5 (0.4)
FW RV	FW RV	Forward control input Reverse control input		Minimum: 10 mA, 24 VDC State 0: V < 5 V, I < 2.5 mA State 1: V > 11 V, I > 6 mA Impedance = 1.5 kΩ	14 (1.5)	3.5 (0.4)

[1] Contact state shown with drive controller deenergized.

[2] Relay coil deenergizes on fault.

[3] Figure 8 is a general representation. Refer to the actual drive controller power board for location of J8- and J9+.

Note: The reference and control inputs are isolated from the mains voltage.

Wiring Diagram

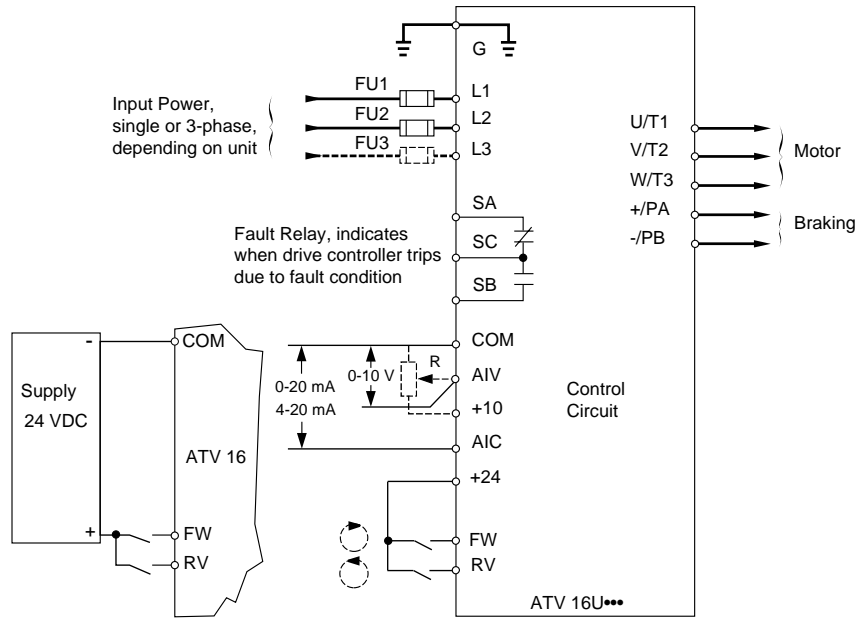

Figure 9 ALTIVAR 16 Drive Controller Wiring Diagram

DRIVE CONTROLLER SET UP

Factory Settings

Table 5 ALTIVAR 16 Drive Controller Factory Settings

Parameter	Setting	Description
Nominal motor voltage	ATV...M2: 230 V ATV...N4: 400 V [1,2]	Rated nameplate voltage of motor. See page 15.
Nominal motor frequency	50 Hz [1,2]	Output frequency selection at rated motor voltage. See page 15.
Maximum frequency	50 [1,2]	Maximum output frequency (Hz). See page 15.
Selection of type of V/f ratio	n [1,2]	Selection of V/f ratio: n: Standard applications at constant torque. P: Variable torque applications (pumps, fans). L: Machines requiring high torque at low speed, machines with fast cycles, special motors.

[1] Modifiable with display/adjustment option.

[2] Modifiable with PC connection option.

Table 5 ALTIVAR 16 Drive Controller Factory Settings (Continued)

Parameter	Setting	Description
Switching frequency	5 kHz ^[2]	Carrier frequency of the output pulses. Factory setting of 5 kHz can be increased to 10 kHz for less audible motor noise. When switching frequency is increased to 10 kHz, drive controller output current rating must be derated by 20%.
Deceleration ramp adaptation	Yes ^[1,2]	If set to Yes and initial deceleration ramp time is too low, automatically extends deceleration ramp time, accounting for load inertia.
Slip compensation	Yes ^[1,2]	If set to Yes, drive controller maintains a constant speed to the motor for a given reference as the load changes, automatically adjusting the output frequency.
Automatic DC injection	$f < 0.1$ Hz ^[2]	DC injection braking at the end of the deceleration ramp. If enabled, will be injected when $f < 0.1$ Hz or when $f < LSP$, depending on setting.
DC current level	$0.7 I_{th}$ ^[2]	Amount of DC injected at the end of the deceleration ramp. I_{th} = Motor thermal overload protection setting.
DC current time	0.5 s ^[2]	Length of time DC is injected at the end of the deceleration ramp.
Automatic restart	No ^[2]	If set to Yes, enables drive controller to automatically restart after an overvoltage ($U5F$), overload ($U1F$) or overbraking ($U6F$) fault. For $U5F$ and $U6F$ faults, drive controller remains disabled for 1 minute after fault appears, causing fault relay of drive controller to engage, then restarts automatically if fault has disappeared. If fault is present at end of 1 minute, drive controller must be reset manually. Drive controller will attempt 5 automatic restarts (one every minute) before it must be manually reset. For $U1F$ fault, the restart is effective as soon as the thermal state drops below 100%, usually about 7 minutes after fault occurs.

⚠ WARNING
<p>UNINTENDED EQUIPMENT ACTION.</p> <ul style="list-style-type: none"> • Automatic restart and catching a spinning load can only be used for machines or installations that present no danger in the event of automatic restarting, either for personnel or equipment. • Equipment operation must conform with national and local safety regulations. <p>Failure to observe these precautions can result in severe personal injury or equipment damage.</p>

Catching a spinning load	No ^[2]	When set to Yes, allows smooth restarting of motor after a brief input line undervoltage. If the reference signal and a direction command are maintained, motor accelerates back up to speed without starting at zero.
--------------------------	-------------------	--

^[1] Modifiable with display/adjustment option.

^[2] Modifiable with PC connection option.

Table 5 ALTIVAR 16 Drive Controller Factory Settings (Continued)

Parameter	Setting	Description
Controlled stop on loss of AC supply	No ^[2]	When set to Yes, at loss of input power, deceleration follows a self-adjusting ramp, which is a function of the regenerated energy. When set to No, motor coasts to a stop.
Ramp type	Linear ^[2]	Determines type of acceleration and deceleration ramps (linear or S). See diagrams below. <div style="text-align: center;"> </div>
Current limit	1.35 Drive Controller I _n	Current limit value. Drive controller I _n = rated output current.
Acceleration	3 s ^[1,2]	Length of time to accelerate to nominal motor frequency from zero speed.
Deceleration	3 s ^[1,2]	Length of time to decelerate from nominal motor frequency to zero speed.
Low speed	0 Hz ^[1,2]	Low speed setting.
High speed	50 Hz ^[1,2]	High speed setting. See page 15.
V/f ratio	20 ^[1,2]	Adjustment of amount of motor torque supplied by the motor at low speed.
Motor thermal overload protection	0.9 Drive Controller I _n ^[1,2]	See page 17. Drive controller I _n = rated output current.
Frequency loop gain	33% ^[1,2]	Amount of frequency loop gain for maximizing motor torque.

^[1] Modifiable with display/adjustment option.

^[2] Modifiable with PC connection option.

Switch Settings

Figure 10 shows the location of the drive controller configuration switches. **Make adjustments with power removed.**



Figure 10 Drive Controller Configuration Switches

Volts/Frequency Ratio Configuration

Figure 11 shows selections available by changing switch 1 on front of the drive controller. Switch 1 configures the volts/frequency ratio.

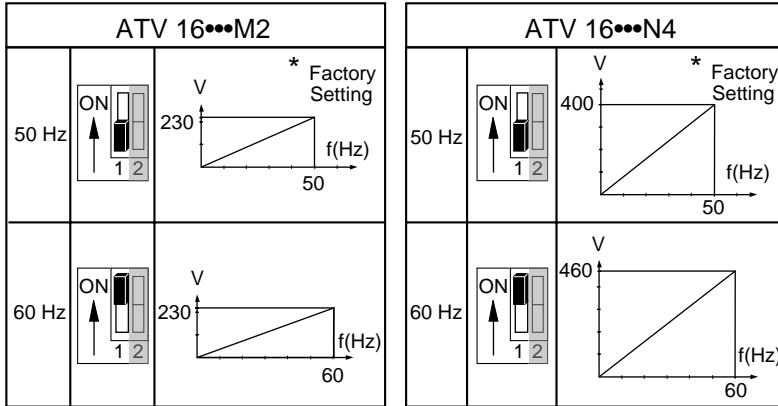

Figure 11 Configuring Switch 1

Current Speed Reference Input Configuration

Figure 12 shows selections available by changing switch 2 on front of the drive controller. Switch 2 configures the speed reference input. When it is set to 4-20 mA (switch 2 ON), the reference voltage (AIV) is from 2 to 10 V.

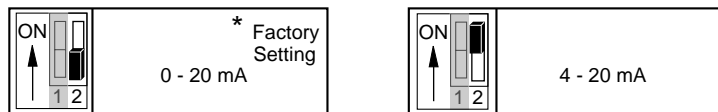

Figure 12 Configuring Switch 2

2-WIRE TRANSITIONAL CONTROL

For drive controllers containing V2.1 IE07 or later software, setting switch 1 on the control board to 60 Hz provides “2-wire transitional” control (see Figure 13). If FW or RV is high (state 1) and a reference frequency is present when the drive controller is powered up, the drive controller will not run. FW or RV must transition from low (state 0) to high (state 1) for the drive controller to start.

If switch 1 on the control board is set for 50 Hz, the drive controller provides standard 2-wire control (see Figure 14). If FW or RV is high (state 1) and a reference frequency is present when the drive controller is powered up, the drive controller will run at the commanded frequency.

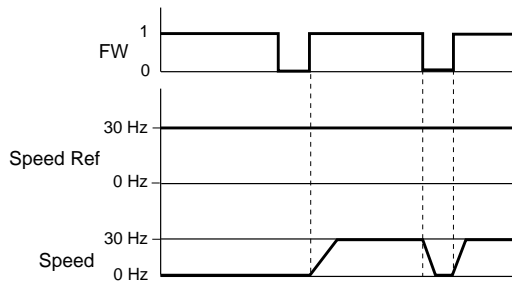

Figure 13 2-Wire Transitional Control

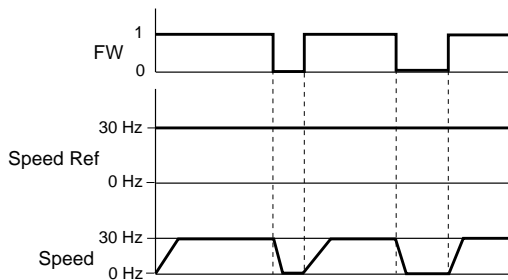
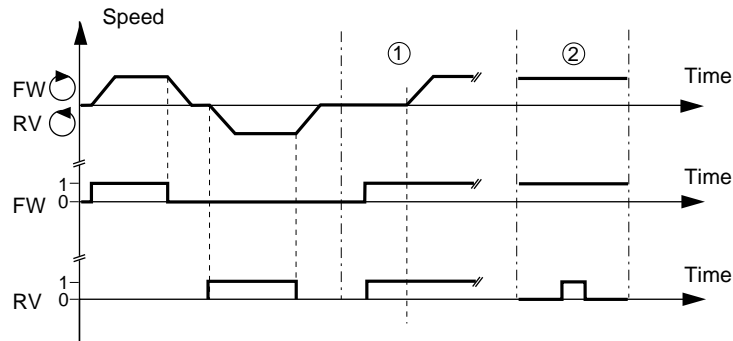

Figure 14 Standard 2-Wire Control

Note: If standard 2-wire control and 60 Hz operation is desired, leave switch 1 in the 50 Hz position and adjust the necessary parameters with the display adjustment option or the PC connection option.

DIRECTION OF ROTATION

Figure 15 shows how the FW and RV inputs control the rotation direction of the drive controller.



- ① When both FW and RV are selected, the forward direction has priority.
- ② Direction control input selected first takes priority over the other.

Figure 15 Direction of Rotation

THERMAL OVERLOAD PROTECTION OF THE MOTOR

Thermal overload protection to the motor is accomplished by:

- The I^2t thermal protection of the drive controller if the nominal motor current is equal to 0.9 times the drive controller rated output current. For use in the 25/30 to 50/60 Hz frequency range. The value of the motor thermal protection can be changed with display/adjustment option.
- A thermal sensor integral to the motor when high torque at base speed is required.
- An external thermal overload relay.

CAUTION

LOSS OF MOTOR OVERLOAD PROTECTION.

When using external overload relays connected to the drive controller output, the overload relay must be capable of operation over the expected range of drive controller output frequencies (including direct current).

When DC injection braking is used:

- The overload relay must be suitable for operation with direct current flowing in the motor.
- Do not use overload relays equipped with current transformers for sensing the motor current.

Failure to observe these precautions can result in equipment damage.

⚠ CAUTION

MOTOR OVERHEATING.

This drive controller does not provide direct thermal protection for the motor. Use of a thermal sensor in the motor may be required for protection at all speeds and loading conditions. Consult motor manufacturer for thermal capability of motor when operated over desired speed range.

Failure to observe this precaution can result in personal injury or equipment damage.

AVAILABLE TORQUE

Continuous duty:

- For self-ventilated motors, motor cooling depends on the speed.
- This results in derating for speeds less than 50% of the nameplate motor speed. For fractional powers $\leq 1/3$ hp (250 W), the derating is less (e.g., 20% instead of 50% at the lowest frequency).

Transient duty:

- The possibility of overtorque depends on the maximum amount of transient current that the drive controller is capable of delivering.

Figure 16 shows the typical torque characteristics of the ALTIVAR 16 drive controller.

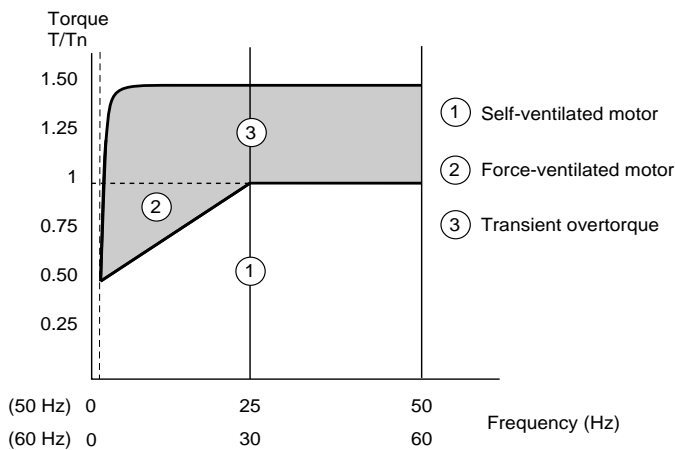

Figure 16 Typical ALTIVAR 16 Drive Controller Torque Characteristics

PREVENTIVE MAINTENANCE

Read the safety statements below before proceeding with any maintenance or troubleshooting procedures.

⚠ DANGER

HAZARDOUS VOLTAGE.

- Read and understand this manual in its entirety before installing or operating AC drive controllers. Installation, adjustment, repair and maintenance of these drive controllers must be performed by qualified personnel.
- Disconnect all power before servicing drive controller. WAIT ONE MINUTE until bus capacitors discharge, then measure bus capacitor voltage between J9+ and J8- terminals to verify DC voltage is less than 45 V. See page 6.
- DO NOT short across capacitors or touch unshielded components or terminal strip screw connections with voltage present.
- Install all covers and close door before applying power or starting and stopping the drive controller.
- User is responsible for conforming to all applicable code requirements with respect to grounding all equipment. For more information on grounding, see page 9.
- Many parts, including printed wiring boards, in this drive controller operate at line voltage. DO NOT TOUCH. Use only electrically insulated tools while making adjustments.

Before servicing the drive controller:

- Disconnect all power.
- Place a "DO NOT TURN ON" label on the drive controller disconnect.
- Lock disconnect in open position.

Failure to observe these precautions will cause burn or shock, resulting in death or severe personal injury.

The following preventive maintenance procedures are recommended at regular intervals:

- Check the condition and tightness of the connections.
- Make sure ventilation is effective and temperature around the drive controller remains at an acceptable level.
- Remove dust and debris from the drive controller, if necessary.

If anything unusual occurs when putting the drive controller into service or during operation, be sure all recommendations relating to the environment, mounting and connecting the drive controller have been followed.

DIAGNOSTICS

The LEDs on front of the ALTIVAR 16 drive controller indicate several states (see Figure 17).



Red LED		Illuminated: fault
Green LED		Not illuminated: no power to the drive
Green LED		Illuminated: drive powered, DC bus ≥ 50 V

Figure 17 LED States

Fault Storage

When a fault occurs:

- The first fault detected is stored if mains voltage is maintained.
- The fault relay opens.

To reset the fault:

- Remove power from the drive controller.
- Before switching power back on, identify and correct the cause of the fault.
- Restore power. This will reset the fault if it has been corrected.

Note: *Display/adjustment options VW3-A16101 and VW3-A16102 display the fault codes.*

ADDITIONAL DOCUMENTATION

Table 6 Documentation for ALTIVAR 16 Drive Controller Products

Product	Catalog No.	Bulletin No.
ALTIVAR 16 Adjustable Speed AC Drive Controller (base product)	ATV 16****	50006-360-01
Display/Adjustment Options:		
Display/Adjustment	VW3-A16101	50006-360-02
Display/Adjustment/Local Control	VW3-A16102	50006-360-02
Display/Adjustment Remote Mounting Kit	VW3-A16103	50006-360-02
PC Connection	VW3-A16104	50006-360-03
Dynamic Braking Module	VW3-A16601	50006-360-08
Dynamic Braking Resistor	VW3-A16705	50006-360-04
RFI Filters	VW3-A16401-07	50006-360-09
Inductors (line reactors)	VW3-A16501-04	50006-360-10
Option cards:		
General Use/Material Handling	VW3-A16201	50006-360-05
Variable Torque	VW3-A16202	50006-360-06
High Speed Motor	VW3-A16203	50006-360-07
General Use 3-Wire Control	VW3-A16204	50006-360-11

50006-360-01A
August, 1995

ALTIVAR 16 Drive Controller
for Asynchronous Motors



GROUPE SCHNEIDER

■ Merlin Gerin ■ Square D ■ Telemecanique

99646

VD0C01S301