

ALTIVAR 58 Quick Reference Guide

Menu Structure & Reference

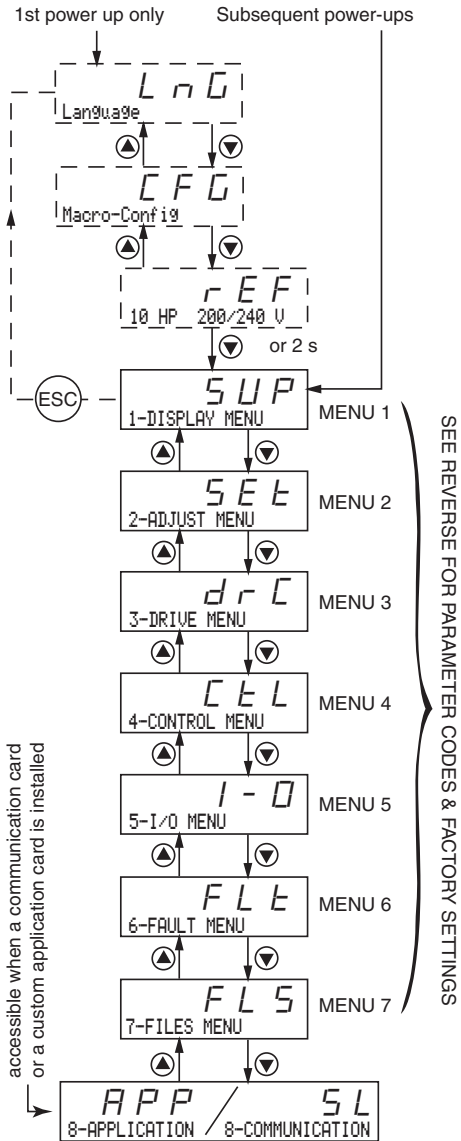

Programming Example: Acceleration Time

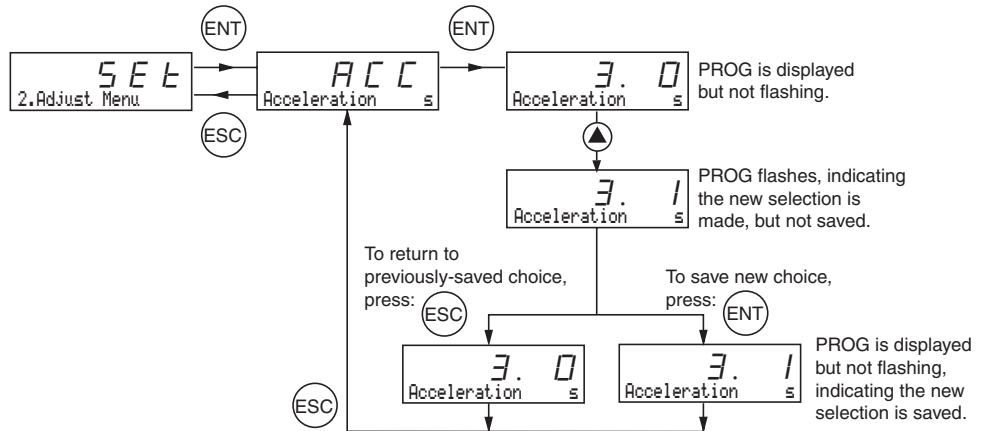

Programming Example: File Operation

Store, Recall, or Reinitialize the Drive Configuration

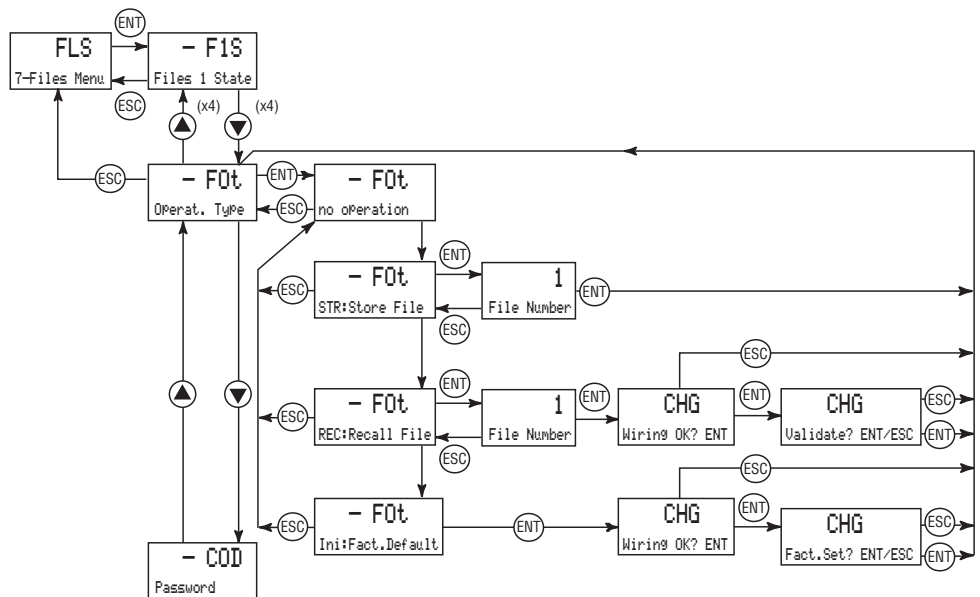

Control Terminals

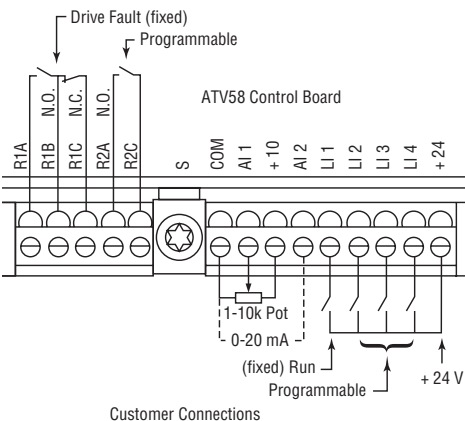

Macro-Configuration Menu

Macro-Configuration provides initial setup configurations to support ease of setup for three types of applications. These settings can be changed by the user to match individual application requirements.

Macro-Configuration Assignments

	Hdg: Material Handling ^[1]	Gen: General Use	VT: Variable Torque
Logic Input LI1	Forward	Forward	Forward
Logic Input LI2	Reverse	Reverse	Reverse
Logic Input LI3	2 Preset speeds	Jog	Auto/manual
Logic Input LI4	4 Preset speeds	Freewheel stop ^[2]	DC injection braking
Analog Input AI1	Reference summing	Reference summing	Speed reference 1
Analog Input AI2	Reference summing	Reference summing	Speed reference 2
Relay R1	Drive fault relay	Drive fault relay	Drive fault relay
Relay R2	Output contactor command	Motor thermal state attained	Frequency reference attained

^[1] Factory default setting.

^[2] If the Freewheel Stop/ Run Permissive function is configured, the drive controller will not start the motor unless the logic input is connected to +24 V.

Note: LI1, AI1, and R1 assignments are not visible in the I/O menu. They cannot be reassigned.

WARNING

UNINTENDED CONFIGURATION CHANGES

Changing the macro-configurations or installing a new option card reconfigures the drive to factory settings.

Failure to follow this instruction can result in death or serious injury.

Menu 1 – DISPLAY Menu

Parameter	Code
Drive State	rDY
Steady State	rUn
Accelerating	ACC
Decelerating	dEc
In Current Limit	CLi
DC Injection Braking	dCb
Freewheel Stop	nSt
Braking with Ramp Mod	Obr
Frequency Reference	FrH
Output Frequency	rFr
Motor Speed	SPd
Motor Current	LCr
Machine Speed	USP
Output Power	OPr
Mains Voltage	ULn
Motor Thermal	tHr
Drive Thermal	tHd
Last Fault	Lft
Consumption (wH)	APH
Run Time (Hours)	rLH

Menu 2 – ADJUST Menu

Parameter	Code	Factory Setting
Frequency Reference	LFr	
Acceleration	-s ACC	3 s
Deceleration	-s dEC	3 s
Accelerate 2	-s AC2	5 s
Decelerate 2	-s dE2	5 s
Low Speed	-Hz LSP	0 Hz
High Speed	-Hz HSP	50 / 60 Hz
Gain	-% FLG	20%
Stability	-% StA	20%
Thermal Current	-A tH	0.9 in
DC Injection Time	-s tDC	0.5 s
DC Injection Curr	-A IdC	0.7 lth
DC Injection Curr	-A SdC	Varies
Jump Freq.	-Hz JPF	0 Hz
Jump Freq. 2	-Hz JF2	0 Hz
Jump Freq. 3	-Hz JF3	0 Hz
LSP Time	-s tLS	no
Machine Speed Coeff.	USC	1
IR Compensation	-% UFr	100%
Slip Comp.	-% SLP	100%
Preset Sp.2	-Hz SP2	10 Hz
Preset Sp.3	-Hz SP3	15 Hz
Preset Sp.4	-Hz SP4	20 Hz
Preset Sp.5	-Hz SP5	25 Hz
Preset Sp.6	-Hz SP6	30 Hz
Preset Sp.7	-Hz SP7	35 Hz
Frequency Lev.Att	-Hz FtD	50 / 60 Hz
Frequency Lev2.Att	-Hz F2d	
Torque Limit 2	-% tL2	200%
Current Level Att.	-A CtD	1.36 In
Brake Release Lev	-Hz brL	0 Hz
Brake Release I	-A Ibr	0 A
Brake ReleaseTime	-s brt	0 s
Brake Engage Lev	-Hz bEn	0 Hz
Brake EngageTime	-s bEt	0 s
Trip Threshold NST	-Hz FtT	
Tachometer Coeff. *	dTS	1
Current Level Att.	A * CtD	
Jog Freq.	-Hz JOG	10 Hz
Jog Delay	-s JGt	0.5 s
V/f Profile	-% PFL	20%
Thermal Level Att.	-% tTd	100%
PID Prop. Gain	rPG	1
PID Int. Gain	-/s rIG	1/s
PID Filter	PSP	
PID Coeff	FbS	0.1
PID Inversion	PIC	no

Menu 3 – DRIVE Menu

Parameter	Code	Factory Setting
Nom. Motor Volt	-V UnS	depends on cat. #
Nom. Motor Freq.	-Hz FrS	50 / 60 Hz
Nom. Motor Curr	-A nCr	0.9 In
Nom. Motor Speed	-rpm nSP	depends on cat. #
Motor CosPhi (power fact.)	CoS	depends on cat. #
Auto Tuning	tUn	no
Max. Frequency	-Hz tFr	60 / 72 Hz
Energy Economy	nLd	no
I Limit Adapt.	Fdb	no
Dec Ramp Adapt	brA	no
Switch Ramp 2	-Hz Frt	0 Hz
Type of Stop	Stt	Stn
Standard Stop	Stn	
Fast Stop	FSt	
Freewheel	nSt	
DC Injection	DCI	
Ramp Type	rPt	LIn
Linear Ramp	LIn	
S Ramp	S	
U Ramp	U	
Dec Ramp Coef.	dCF	4
Torque Limit	-% tLI	200 %
Int. I Limit	-% CLi	1.36 In
Auto DC Inj.	AdC	yes
Mot. Power Coef.	PCC	1
Switching Freq. Type	SFT	LF
Range of 0.5 to 4 kHz	LF	depends on cat. #
Range of 4 to 16 kHz	HF1	depends on cat. #
High Duty Cycle w/ derat.	HF2	depends on cat. #
Sw. Freq 0.5 to 16	-kHz SFr	0.5 to 16 kHz
Noise Reduction	nrd	yes
Special Motor	SPC	no
PG (feedback sensor)Type *	PGt	dEt
Incremental Encoder	InC	
Detector (pulse or edge)	dEt	
Num. Pulses *	PLS	1

Menu 4 – CONTROL Menu

Parameter	Code	Factory Setting
Terminal Strip Con	tCC	2 W
Two Wire 2W	2 W	
Three Wire 3W	3 W	
Type 2 Wire	tCt	LEL
No Transition	LEL	
Low to High Trans.	trn	
Forward Input Pri.	PFW	
Inhibit Reverse	rIn	no
Low Speed Magmt	bSP	no
Linear LSP to HSP	no	
Pedestal Start	BLS	
Deadband Start	BnS	
AI2 Min. Ref.	-mA CrL	4 mA
AI2 Max. Ref.	-mA CrH	20 mA
Min. Val. AO *	mA AOL	0 mA
Max. Val. AO *	mA AOH	20 mA
Reference Memory	Str	no
No memory	no	
Run Com. removed	RAM	
Power removed	EEP	
Keypad Com.	LCC	no
Stop Priority	Pst	yes
Drive Address	Add	0
Bd Rate RS485	tbr	
Reset Counters	rPr	

Menu 6 – FAULT Menu

Parameter	Code	Factory Setting
Auto Restart	ARr	no
Reset Type	rSt	RSP
Partial Reset	rSP	
Total Reset	rSG	
Output Phase Loss	OPL	yes
Input Phase Loss	IPL	yes
Thermal Protection	tHt	ACL
No motor protection	no	
Self Cooled motor	ACL	
Force Cooled motor	FCL	
Loss Follower	LFL	no
Catch On Fly	FLr	no
Controlled Stop	StP	no
Phase loss drive trip	no	
Regen w/dc Bus	nmS	
Follow dc bus	FrP	
Ramp not Followed *	Sdd	no

Menu 5– I/O Menu

Parameter	Code	Factory Setting
LI2 Assign	LI2	
LI3 Assign	LI3	
LI4 Assign	LI4	
LI5 Assign *	LI5	
LI6 Assign *	LI6	
Not assigned	no	
RV: Reverse	RV	
Switch Ramp2	RP2	
JOG	JOG	
+SP: +Speed	SP	
-Speed	-SP	
2 preset Sp	PS2	
4 preset SP	PS4	
8 preset Sp	PS8	
Freewheel Stop	nSt	
DC inject	DCI	
Fast stop	FSt	
Multi. Motor	CHP	
TorqueLim2	tL2	
Forced Local	FL0	
Fault Reset	rSt	
Auto/manu	rFC	
Auto-tune	Atn	
PID Auto/Man	PAU	
PID 2 Preset	Pr2	
PID 4 Preset	Pr4	
Torque Limit by AI	tLA	
AI2 Assign	AI2	
AI3 Assign *	AI3	
Not assigned	no	
Speed ref 2	Fr2	
Summed ref.	SAI	
PID regulator	PIF	
PID Manual Ref.	PIM	
Tacho feedback *	SfB	
Therm. Sensor *	PtC	
Torque Limit *	AtL	
Encoder feedback *	rGI	
R2 Assign / LO assign	r2 / LO	
Not assigned	no	
Drive running	rUn	
Output contactor	OCC	
Freq reference attain.	FtA	
HSP attained	FLA	
Current level attained	CtA	
Reference Freq. Attain.	SrA	
Motor thermal lv1	tSA	
Brake logic	bLC	
4-20mA loss	APL	no
F2 attained	F2A	
AO Assign *	AO	
Not assigned *	no	
Motor current *	OCr	
Motor frequency *	OFr	
Output ramp *	OrP	
Motor torque *	trq	
Signed Torque *	Stq	
Signed Ramp *	OrS	
PID Reference *	OPS	
PID Feedback *	OPF	
PID Error *	OPe	
PID Integral *	OPI	
Motor Power *	OPr	
Motor Thermal *	tHr	
Drive Thermal *	tHd	

Menu 7 – FILES Menu

Parameter	Code	Factory Setting
File 1 State	F1S	FRE
File 2 State	F2S	FRE
File 3 State	F3S	FRE
File 4 State	F4S	FRE
Operation Type	F0t	no
No Operation Req.	no	
Save Configuration	Str	
Transfer File to Drive	rEC	
Return to Factory Set	InI	
File Number	FLn	
Password	Cod	0000

* Requires addition of I/O option card VW3A58201U (analog) or VW3A58202U (digital)

Electrical equipment should be serviced only by qualified personnel. No responsibility is assumed by Schneider Electric for any consequences arising out of the use of this material. This document is not intended as an instruction manual for untrained persons.