



PositionServo (MVCD)
Users Manual

Copyright ©2005 by Lenze AC Tech Corporation.

All rights reserved. No part of this manual may be reproduced or transmitted in any form without written permission from Lenze AC Tech Corporation. The information and technical data in this manual are subject to change without notice. Lenze AC Tech makes no warranty of any kind with respect to this material, including, but not limited to, the implied warranties of its merchantability and fitness for a given purpose. Lenze AC Tech assumes no responsibility for any errors that may appear in this manual and makes no commitment to update or to keep current the information in this manual.

MotionView®, PositionServo®, and all related indicia are either registered trademarks or trademarks of Lenze AG in the United States and other countries.

This document printed in the United States of America.



1	Introduction	5
1.1	About These Instructions	6
1.2	Scope of Supply	6
1.3	Legal Regulations	6
1.4	Part Number Designation	7
2	Technical Data	9
2.1	Electrical Characteristics	9
2.2	Power Ratings	10
2.3	Fuse Recommendations	10
2.4	Digital I/O Ratings	11
2.5	Environment	11
2.6	Operating Modes	11
2.7	Connections and I/O	11
2.8	PositionServo Dimensions	12
2.9	Clearance for Cooling Air Circulation	13
3	Installation	14
3.1	Wiring	15
3.2	Shielding and Grounding	15
3.2.1	General Guidelines	15
3.2.2	EMI Protection	16
3.2.3	Enclosure	16
3.3	Line Filtering	17
3.4	Heat Sinking	17
3.5	Line (Mains) Fusing	17
4	Interface	18
4.1	External Connectors	18
4.1.1	P1 & P7 - Input Power and Output Power Connections	18
4.1.2	P2 - Ethernet Communications Port	19
4.1.3	P3 - Controller Interface	20
4.1.4	P4 - Motor Feedback / Second Loop Encoder Input	21
4.1.5	P5 - 24 VDC Back-up Power Input	22
4.1.6	P6 - Braking Resistor and DC Bus	22
4.1.7	Connector and Wiring Notes	23
4.1.8	P11 - Resolver Interface Module (option)	24
4.1.9	P12 - Second Encoder Interface Module (option)	25
4.2	Digital I/O Details	26
4.2.1	Step & Direction / Master Encoder Inputs (P3, pins 1-4)	26
4.2.2	Buffered Encoder Output (P3, pins 7-12)	27
4.2.3	Digital Outputs	27
4.2.4	Digital Inputs	28
4.3	Analog I/O Details	29
4.3.1	Analog Reference Input	29
4.3.2	Analog Output	30
4.4	Communication Interfaces	30
4.4.1	Ethernet Interface (standard)	30
4.4.2	RS485 Interface (option)	30
4.4.3	RS485 Communication Setup	31
4.4.4	MODBUS RTU Support	31
4.4.5	CAN Interface (option)	31
4.5	Motor Selection	31
4.5.1	Motor Connection	31
4.5.2	Motor Over-temperature Protection	32
4.5.3	Motor Setup	32



Contents

4.6	Using a Custom Motor	33
4.6.1	Creating Custom Motor Parameters	33
4.6.2	Autophasing	34
4.6.3	Custom Motor Data Entry	34
5	Parameters	39
5.1	Parameter Storage and EPM Operation	39
5.1.1	Parameter Storage	39
5.1.2	EPM Operation	39
5.1.3	EPM Fault	39
5.2	Motor Group	40
5.3	Parameters	40
5.3.1	Drive Operating Modes	40
5.3.2	Drive PWM frequency	41
5.3.3	Current Limit	41
5.3.4	Peak Current Limit (8 kHz and 16 kHz)	41
5.3.5	Analog Input Scale (current scale)	41
5.3.6	Analog Input Scale (velocity scale)	41
5.3.7	ACCEL/DECEL Limits (velocity mode only)	42
5.3.8	Reference	42
5.3.9	Step Input Type (position mode only)	42
5.3.10	Fault Reset Option	42
5.3.11	Motor Temperature Sensor	42
5.3.12	Motor PTC Cut-off Resistance	42
5.3.13	Second Encoder	42
5.3.14	Regeneration Duty Cycle	43
5.3.15	Encoder Repeat Source	44
5.3.16	System to Master Ratio	44
5.3.17	Second to Prime Encoder Ratio	44
5.3.18	Autoboot	44
5.3.19	Group ID	44
5.3.20	Enable Switch Function	44
5.3.21	User Units	44
5.3.22	Resolver Track	44
5.3.23	Current Limit Max Overwrite	45
5.4	Communication	45
5.4.1	Ethernet Interface	45
5.4.2	RS-485 Configuration	48
5.4.3	Modbus Baud Rate	48
5.4.4	Modbus Reply Delay	48
5.5	Analog I/O	48
5.5.1	Analog Output	48
5.5.2	Analog Output Current Scale (Volt / amps)	49
5.5.3	Analog Output Current Scale (mV/RPM)	49
5.5.4	Analog Input Dead Band	49
5.5.5	Analog Input Offset Parameter	49
5.5.6	Adjust Analog Input Zero Offset	49
5.6	Digital I/O	49
5.6.1	Digital Input De-bounce Time	49
5.6.2	Hard Limit Switch Action	50
5.7	Velocity Limits	50
5.7.1	Zero Speed	50
5.7.2	Speed Window	50
5.7.3	At Speed	50
5.8	Position Limits	50
5.8.1	Position Error	50
5.8.2	Max Error Time	50
5.8.3	Second Encoder Position Error	50
5.8.4	Second Encoder Max Error Time	50



5.9	Compensation	.51
5.9.1	Velocity P-gain (proportional)	.51
5.9.2	Velocity I-gain (integral)	.51
5.9.3	Position P-gain (proportional)	.51
5.9.4	Position I-gain (integral)	.51
5.9.5	Position D-gain (differential)	.51
5.9.6	Position I-limit	.51
5.9.7	Gain Scaling Window	.52
5.10	Tools	.52
5.10.1	Oscilloscope Tool	.52
5.10.2	Run Panels	.52
5.11	Faults	.52
6	Operation	53
6.1	Minimum Connections	.53
6.2	Configuration of the PositionServo	.53
6.3	Position Mode Operation (gearing)	.55
6.4	Dual-loop Feedback	.55
6.5	Enabling the PositionServo	.56
6.6	Drive Tuning	.56
6.6.1	Tuning the Drive in Velocity Mode	.57
6.6.2	Tuning the Drive in Position Mode	.62
7	Quick Start Reference	68
7.1	Quick Start - External Torque Mode	.68
7.2	Quick Start - External Velocity Mode	.69
7.3	Quick Start - External Positioning Mode	.71
8	Diagnostics	73
8.1	Display	.73
8.2	LEDs	.74
8.3	Faults	.74
8.3.1	Fault Codes	.74
8.3.2	Fault Event	.76
8.3.3	Fault Reset	.76
8.4	Troubleshooting	.76

Safety Information





All safety information given in these Operating Instructions has a similar layout:



Signal Word! (Characteristics the severity of the danger)

Note (describes the danger and informs on how to proceed)

Pictographs used in these instructions:

Icon		Signal Words	
	Warning of hazardous electrical voltage	DANGER!	Warns of impending danger . Consequences if disregarded: Death or severe injuries.
	Warning of a general danger	WARNING!	Warns of potential, very hazardous situations . Consequences if disregarded: Death or severe injuries.
	Warning of damage to equipment	STOP!	Warns of potential damage to material and equipment . Consequences if disregarded: Damage to the controller/drive or its environment.
	Information	NOTE	Designates a general, useful note. If you observe it, handling the controller/drive system is made easier.



1 Introduction

The PositionServo line of advanced general purpose servo drives utilizes the latest technology in power semiconductors and packaging. The PositionServo uses Field Oriented control to enable high quality motion.

The PositionServo is available in four mains (input power) configurations:

1. **400/480V** (nominal) three phase input. An external input mains (line) filter is available. Actual voltage can range from 320 - 528 VAC.
2. **120/240V** (nominal) Single Phase input with integrated input mains (line) filter, Actual input voltage can range from 80VAC to 264VAC. The maximum output voltage is approximately equal to the input voltage.
3. **120V or 240V** (nominal) Single or Three Phase input. Actual input voltage can range from 80VAC to 264VAC. The maximum output voltage is approximately equal to the input voltage. An external input mains (line) filter is available.
4. **120V or 240V** (nominal) single phase input. When wired for **Doubler mode** (L1-N), the input is for 120V nominal only and can range from 45VAC to 132 VAC and the maximum output voltage is double the input voltage. When wired to terminals L1-L2/N, the input can range from 80 VAC to 264 VAC and the maximum output voltage is equal to the input voltage.

The PositionServo drive can operate in one of three mode settings, torque (current), velocity, or position (step & direction or master encoder). The drive's command or reference signal can come from one of three sources. The first is an external reference. An external reference can be an analog input signal, a step and direction input or an input from a master encoder. The second reference is an internal reference. An internal reference is when the commanded move is derived from the drive's user program. The third reference is when the commanded move is done via a host device over a communications network. This Host device can be an external motion controller, PLC, HMI or PC. The communication network can be RS485 (Point-to-Point or Modbus RTU), Ethernet (using MotionView DLL's), Modbus over TCP/IP, or CANopen (DS301).

Depending on the primary feedback, there are two types of drives: the Model 940 PositionServo encoder-based drive which accepts an incremental encoder with Hall channel inputs and the Model 941 PositionServo resolver-based drive which accepts resolver inputs. The feedback signal is brought back to the P4 connector on the drive. This connector will be a 15 pin D-sub for the encoder version and a 9 pin D-sub for the resolver version. A second encoder can be used in position and velocity modes.

The MotionView software is the setup and management tool for PositionServo drives. All parameters can be set and monitored via this user-friendly tool. It has a real-time oscilloscope tool for analysis and optimum tuning. The users program written with SimpleMotion Programming Language (SML) can be utilized to command motion and handle the drive's inputs/outputs (I/O). The programming language is designed to be very intuitive and easy to implement. For programming details, refer to the PositionServo Programming Manual. All PositionServo related manuals can be downloaded from the Technical Library on the AC Tech website (<http://www.lenze-actech.com>).

On each PositionServo drive, there is an Electronic Programming Module (EPM), which stores all drive setup and tuning information. This module can be removed from the drive and reinstalled into another drive, making the field replacement of the drive extremely easy. This also makes it easy to duplicate the settings for several drives.

The PositionServo drive supports a variety of communication protocols, including Point-to-Point (PPP), Modbus RTU over RS485, Ethernet TCP/IP, Modbus over TCP/IP and CANopen (DS301).





Introduction

1.1 About These Instructions

These Operating Instructions are provided to assist the user in connecting and commissioning the PositionServo drive with model number ending in "EX" or "RX". Read this manual in its entirety and observe all safety instructions contained in this document.

All persons working on or with the controller must have the Operating Instructions available and must observe the information and notes relevant for their work.

A	B	C	D	E	F
Lenze AC Tech Made in USA POSITIONServo Model 940		Type: E94P120Y2NEX ID-No: 13014745  IND. CONT. EQ.	INPUT: 1(3)/PE 120/240 V 24.0 (13.9) A 50-60 HZ 	OUTPUT: 3/PE 0 - 230 V 12.0 A	For detailed information refer to instruction Manual: S94P01 SN 13014745012345678 E94P120Y2NEX0XX###

A	B	C	D	E	F
Certifications	Type	Input Ratings	Output Ratings	Hardware Version	Software Version

1.2 Scope of Supply

Scope of Supply	Important
<ul style="list-style-type: none"> 1 Model PositionServo type E94P or E94R. 1 Users Manual (English) 1 MotionView CD ROM including: <ul style="list-style-type: none"> - configuration software - documentation (Adobe Acrobat) 	<p>After reception of the delivery, check immediately whether the scope of supply matches the accompanying papers. Lenze- AC Tech does not accept any liability for deficiencies claimed subsequently.</p> <p>Claim</p> <ul style="list-style-type: none"> visible transport damage immediately to the forwarder visible deficiencies / incompleteness immediately to your Lenze representative.

1.3 Legal Regulations

Identification	Nameplate	CE Identification	Manufacturer
	Lenze controllers are unambiguously designated by the contents of the nameplate	In compliance with the EC Low-Voltage Directive	AC Technology Corp. member of the Lenze Group 630 Douglas Street Uxbridge, MA 01569 USA
Application as directed	<p>E94P or E94R servo controller</p> <ul style="list-style-type: none"> must only be operated under the conditions prescribed in these Instructions. are components for: <ul style="list-style-type: none"> - closed loop control of variable speed/torque applications with PM synchronous motors. - installation in a machine. - assembly with other components to form a machine. are electric units for installation in control cabinets or similarly enclosed housing. comply with the requirements of the Low-Voltage Directive. are not machines for the purpose of the Machinery Directive. are not to be used as domestic appliances, but only for industrial purposes. <p>Drive systems with E94P or E94R servo inverters</p> <ul style="list-style-type: none"> comply with the EMC Directive if they are installed according to the guidelines of CE-typical drive systems. can be used for: <ul style="list-style-type: none"> - for operation on public and non-public mains - for operation in industrial premises and residential areas. The user is responsible for the compliance of his application with the EC directives. <p>Any other use shall be deemed as inappropriate!</p>		



Liability	<ul style="list-style-type: none"> The information, data, and notes in these instructions met the state of the art at the time of publication. Claims on modifications referring to controllers that have already been supplied cannot be derived from the information, illustrations, and descriptions. The specifications, processes and circuitry described in these instructions are for guidance only and must be adapted to your own specific application. Lenze does not take responsibility for the suitability of the process and circuit proposals. The specifications in these Instructions describe the product features without guaranteeing them. Lenze does not accept any liability for damage and operating interference caused by: <ul style="list-style-type: none"> - Disregarding the operating instructions - Unauthorized modifications to the controller - Operating errors - Improper working on and with the controller 		
Warranty	<ul style="list-style-type: none"> Warranty conditions: see Sales and Delivery Conditions of Lenze Drive Systems GmbH. Warranty claims must be made to Lenze immediately after detecting the deficiency or fault. The warranty is void in all cases where liability claims cannot be made. 		
Disposal	Material	Recycle	Dispose
	Metal	•	-
	Plastic	•	-
	Assembled PCB's	-	•

1.4 Part Number Designation

The table herein describes the part number designation for the PositionServo drive. The available filter and communication options are detailed in separate tables.

	E94	P	020	S	1	N	E	X
Electrical Products in the 94 Series								
P = PositionServo Model 940 with Encoder Feedback								
R = PositionServo Model 941 with Resolver Feedback								
Drive Rating in Amps:								
020 = 2 Amps 090 = 9 Amps								
040 = 4 Amps 100 = 10 Amps								
050 = 5 Amps 120 = 12 Amps								
060 = 6 Amps 180 = 18 Amps								
080 = 8 Amps								
Input Phase:								
S = Single Phase Input only								
Y = Single or Three Phase Input								
T = Three Phase Input only								
Input Voltage:								
1 = 120 VAC Doubler (120V, 1~ in/ 240V, 3~ out)								
2 = 200/240 VAC								
4 = 400/480 VAC								
Line Filter								
N = No Line Filter								
F = Integrated Line Filter								
Secondary Feedback								
E = Incremental Encoder								
R = Standard Resolver								
EN954-1 Safety Circuit								
X = No EN954 Safety Circuit								



Introduction

Filter Part Number Designation

	E94Z	F	4	T	4	A1
Electrical Option in the 94 Series						
F = EMC Filter						
Filter Current Rating in Amps:						
04 = 4.4 Amps		12 = 12 Amps				
07 = 6.9 Amps		15 = 15 Amps				
10 = 10 Amps		24 = 24 Amps				
Input Phase:						
S = Single Phase						
T = Three Phase						
Max Voltage:						
2 = 240 VAC						
4 = 400/480 VAC						
Degree of Filtering/Variation						
A1 = Industrial/1st Variation						
A2 = Industrial/2nd Variation						

Servo Option Part Number Designation

	E94Z	A	CAN	1
Electrical Option in the 94 Series				
A = COMM, Feedback or Breakout Module				
Module Type:				
CAN = CANopen COMM Module		ENC = 2nd Encoder Feedback Module		
RS4 = RS485 COMM Module		RSV = Resolver Feedback Module		
ETH = Ethernet COMM Module		HBK = Motor Brake Terminal Module		
		TBO = Terminal Block I/O Module		
		SCA = Panel Saver I/O Module		
Variations				
1 = 1st Variation				
2 = 2nd Variation				
3 = 3rd Variation				



2 Technical Data

2.1 Electrical Characteristics

Single-Phase Models					
Type ⁽¹⁾	Mains Voltage ⁽²⁾	1~ Mains Current (doubler)	1~ Mains Current (Std.)	Rated Output Current ⁽⁵⁾	Peak Output Current ⁽⁶⁾
E94_020S1N_X	120V ⁽³⁾ or 240V ⁽⁴⁾	9.7	5.0	2.0	6
E94_040S1N_X		15	8.6	4.0	12
E94_020S2F_X	120 / 240V ⁽⁴⁾ (80 V -0%...264 V +0%)	--	5.0	2.0	6
E94_040S2F_X		--	8.6	4.0	12
E94_080S2F_X		--	15.0	8.0	24
E94_100S2F_X		--	18.8	10.0	30
Single/Three-Phase Models					
Type ⁽¹⁾	Mains Voltage ⁽²⁾	1~ Mains Current	3~ Mains Current	Rated Output Current ⁽⁵⁾	Peak Output Current ⁽⁶⁾
E94_020Y2N_X	120 / 240V ⁽⁴⁾ 1~ or 3~ (80 V -0%...264 V +0%)	5.0	3.0	2.0	6
E94_040Y2N_X		8.6	5.0	4.0	12
E94_080Y2N_X		15.0	8.7	8.0	24
E94_100Y2N_X		18.8	10.9	10.0	30
E94_120Y2~_X		24.0	13.9	12.0	36
E94_180T2~_X	240V 3~ (180 V -0%...264 V +0%)	--	19.6	18.0	54
E94_020T4N_X	400 / 480V 3~ (320 V -0%...528 V +0%)	--	2.7	2.0	6
E94_040T4N_X		--	5.5	4.0	12
E94_050T4N_X		--	6.9	5.0	15
E94_060T4~_X		--	7.9	6.0	18
E94_090T4~_X		--	12.0	9.0	27

- (1) The first "_" equals "P" for the 940 encoder based drive or "R" for the 941 resolver based drive.
When the 10th digit is marked by "-", "N" = No line filter or "F" = Integrated line filter
The second "_" equals "E" for incremental encoder (must have E94P drive) or "R" for the standard resolver (must have E94R drive).
- (2) Mains voltage for operation on 50/60 Hz AC supplies (48 Hz -0% ... 62Hz +0%).
- (3) Connection of 120VAC (45 V ... 132 V) to input power terminals L1 and N on these models doubles the voltage on motor output terminals U-V-W for use with 230VAC motors.
- (4) Connection of 240VAC or 120VAC to input power terminals L1 and L2 on these models delivers an equal voltage as maximum to motor output terminals U-V-W allowing operation with either 120VAC or 230VAC motors.
- (5) Drive rated at 8kHz Carrier Frequency. Derate Continuous current by 17% at 16kHz.
- (6) Peak RMS current allowed for up to 2 seconds. Peak current rated at 8kHz. Derate by 17% at 16kHz.

Applies to all models:

Acceleration Time Range (Zero to Max Speed)	0.1 ... 5x10 ⁶ RPM/sec
Deceleration Time Range (Max Speed to Zero)	0.1 ... 5x10 ⁶ RPM/sec
Speed Regulation (typical)	± 1 RPM
Input Impedance (AIN+ to COM and AIN+ to AIN-)	47 kΩ
Power Device Carrier Frequency (sinusoidal commutation)	8.16 kHz
Encoder Power Supply (max)	+5 VDC @ 300 mA
Maximum Encoder Feedback Frequency	2.1 MHz (per channel)
Maximum Output Frequency (to motor)	400Hz
Resolver Carrier Frequency	4.5 - 5.5kHz (5kHz nominal)
Resolver Turns Ratio between Reference and SIN/COS signal	2:1



2.2 Power Ratings

Type ⁽¹⁾	Output kVA at Rated Output Current (8kHz) ⁽²⁾	Leakage Current	Power Loss at Rated Output Current (8kHz)	Power Loss at Rated Output Current (16 kHz) ⁽³⁾
Units	kVA	mA	Watts	Watts
E94_020S1N_X	0.8	Typically >3.5 mA. Consult factory for applications requiring <3.5 mA.	19	21
E94_040S1N_X	1.7		29	30
E94_020S2F_X	0.8		19	21
E94_040S2F_X	1.7		29	30
E94_080S2F_X	3.3		61	63
E94_100S2F_X	4.2		80	85
E94_020Y2N_X	0.8		19	21
E94_040Y2N_X	1.7		29	30
E94_080Y2N_X	3.3		61	63
E94_120Y2--_X	5.0		114	129
E94_180T2--_X	7.5		171	195
E94_020T4N_X	1.7		31	41
E94_040T4N_X	3.3		50	73
E94_050T4N_X	4.2		70	90
E94_060T4--_X	5.0		93	122
E94_090T4--_X	7.5		138	182

2.3 Fuse Recommendations

Type ⁽¹⁾	AC Line Input Fuse (1ø/3ø)	Miniature Circuit Breaker ⁽⁶⁾ (1ø/3ø)	AC Line Input Fuse ⁽⁴⁾ or Breaker ⁽⁵⁾ (N. America)	DC Bus Input Fuse ⁽⁷⁾
Amp Ratings				
E94_020S1N_X	M20/M10	C20/C10	20/10	10
E94_040S1N_X	M32/M20	C32/C20	30/20	20
E94_020S2F_X	M20	C20	20	15
E94_040S2F_X	M20	C20	20	20
E94_080S2F_X	M32	C32	32	40
E94_100S2F_X	M40	C40	40	45
E94_020Y2N_X	M20/M16	C20/C16	20/15	15
E94_040Y2N_X	M20/M16	C20/C16	20/15	20
E94_080Y2N_X	M32/M20	C32/C20	30/20	40
E94_120Y2--_X	M50/M32	C50/C32	50/30	55
E94_180T2--_X	M40	C40	40	80
E94_020T4N_X	M10	C10	10	10
E94_040T4N_X	M10	C10	10	20
E94_050T4N_X	M16	C16	15	25
E94_060T4--_X	M20	C20	20	30
E94_090T4--_X	M25	C25	25	40

- (1) The first "_" equals "P" for the Model 940 encoder based drive or "R" for the Model 941 resolver based drive. When the 10th digit is marked by "--", "N" = No line filter or "F" = Integrated line filter. The second "_" equals "E" for incremental encoder (must have E94P drive) or "R" for the standard resolver (must have E94R drive).
- (2) At 240 VAC line input for drives with suffixes "S1N", "S2F", "Y2N". At 480 VAC line input for drives with suffixes "T4N".
 - a. The output power is calculated from the formula: output kVA = $[(\sqrt{3}) \times U_{L-L} \times I_{rated}] / 1000$
 - b. The actual output power (kW) depends on the motor in use due to variations in motor rated voltage, rated speed and power factor, as well as actual max operating speed and desired overload capacity.
 - c. Typical max continuous power (kW) for PM servo motors runs 50-70% of the kVA ratings listed.
- (3) At 16 kHz, de-rate continuous current by 17%
- (4) Installations with high fault current due to large supply mains may require a type D circuit breaker.
- (5) UL Class CC or T fast-acting current-limiting type fuses, 200,000 AIC, preferred. Bussman KTK-R, JLN, JJS or equivalent.
- (6) Thermal-magnetic type breakers preferred.
- (7) DC-rated fuses, rated for the applied voltage. Examples Bussman KTM or JLN as appropriate.



2.4 Digital I/O Ratings

	Scan Times	Linearity	Temperature Drift	Offset	Current	Input Impedance	Voltage Range
Units	μs	%	%	%	mA	Ohm	VDC
Digital Inputs⁽¹⁾	512				Depend on load	2.2 k	5-24
Digital Outputs	512				15 max	N/A	30 max
Analog Inputs	512	± 0.013	0.1% per °C rise	± 0 adjustable	Depend on load	47 k	± 18
Analog Outputs	512		0.1% per °C rise	± 0 adjustable	10 max	N/A	± 10

(1) Inputs do not have scan time. Their values are read directly by indexer program statement.
De-bounce time is programmable and can be set as low as 0. Propagation delay is typical 20 us

2.5 Environment

Vibration	2 g (10 - 2000 Hz)
Ambient Operating Temperature Range	0 to 40°C
Ambient Storage Temperature Range	-10 to 70°C
Temperature Drift	0.1% per °C rise
Humidity	5 - 90% non-condensing
Altitude	1500m/5000ft [derate by 1% per 300m (1000 ft) above 1500m (5000 ft)]

2.6 Operating Modes

Torque

Reference	± 10 VDC 16-bit; scalable
Torque Range	100:1
Current-Loop Bandwidth	Up to 1.5 kHz*

Velocity

Reference	± 10 VDC or 0...10 VDC; scalable
Regulation	± 1 RPM
Velocity-Loop Bandwidth	Up to 200 Hz*
Speed Range	5000:1 with 5000 ppr encoder

Position

Reference	0...2 MHz Step & Direction or 2 channels quadrature input; scalable
Minimum Pulse Width	500 nanoseconds
Loop Bandwidth	Up to 200 Hz*
Accuracy	±1 encoder count for encoder feedback ±1.32 arc-minutes for resolver feedback (14-bit resolution)

* = motor and application dependent

2.7 Connections and I/O

Mains Power	4-pin removable terminal block	(P1)
Ethernet Port	Standard RJ45 Connector	(P2)
I/O Connector	Standard 50-pin SCSI.	(P3)
- Buffered Encoder Output	A, B & Z channels with compliments (5V @ 20mA)	(P3)
- Digital Inputs	11 programmable, 1 dedicated (5-24V)	(P3)
- Digital Outputs	4 programmable, 1 dedicated (5-24V @ 15mA)	(P3)
- Analog Input	2 differential; ±10 VDC (one 16 bit, one 10 bit)	(P3)
- Analog Output	1 single ended; ±10 VDC (10-bit)	(P3)
Encoder Feedback (E94P drive)	Feedback connector, 15-pin D-shell	(P4)
Resolver Feedback (E94R drive)	Feedback connector, 9-pin D-shell	(P4)
24VDC Power "Keep Alive"	2-pin removable terminal block	(P5)
Regen and Bus Power	5-pin removable terminal block	(P6)
Motor Power	6-pin pin removable terminal block	(P7)
Resolver Feedback (option bay)	Option module with standard 9-pin D-shell	(P11)
Encoder Feedback (option bay)	Option module with standard 9-pin D-shell	(P12)
Comm Option Bay	Optional Comm Modules (CAN, RS485)	(P21)
Windows® Software:	MotionView (Windows 98, NT, 2000, XP)	



Technical Data

2.8 PositionServo Dimensions

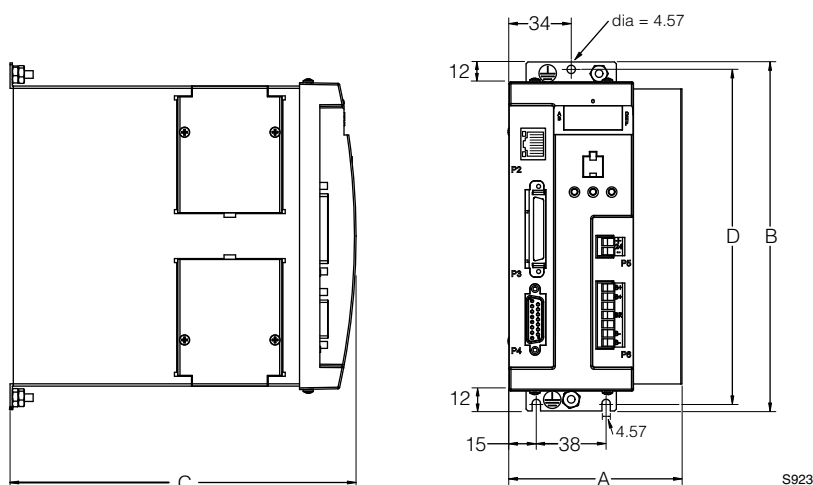

S923

Type ⁽¹⁾	A (mm)	B (mm)	C (mm)	D (mm)	Weight (kg)
E94_020S1N_X	68	190	190	182	1.1
E94_040S1N_X	69	190	190	182	1.2
E94_020S2F_X	68	190	235	182	1.3
E94_040S2F_X	69	190	235	182	1.5
E94_080S2F_X	87	190	235	182	1.9
E94_100S2F_X	102	190	235	182	2.2
E94_020Y2N_X	68	190	190	182	1.3
E94_040Y2N_X	69	190	190	182	1.5
E94_080Y2N_X	95	190	190	182	1.9
E94_100Y2N_X	114	190	190	182	2.2
E94_120Y2~_X	68	190	235	182	1.5
E94_180T2~_X	68	242	235	233	2.0
E94_020T4N_X	68	190	190	182	1.5
E94_040T4N_X	95	190	190	182	1.9
E94_050T4N_X	114	190	190	182	2.2
E94_060T4~_X	68	190	235	182	1.4
E94_090T4~_X	68	242	235	233	2.0

- (1) The first "_" equals "P" for the Model 940 encoder based drive or "R" for the Model 941 resolver based drive. When the 10th digit is marked by "-", "N" = No line filter, "F" = Integrated line filter or "C" = Cold plate drive. The second "_" equals "E" for incremental encoder (must have E94P drive) or "R" for the standard resolver (must have E94R drive).



2.9 Clearance for Cooling Air Circulation

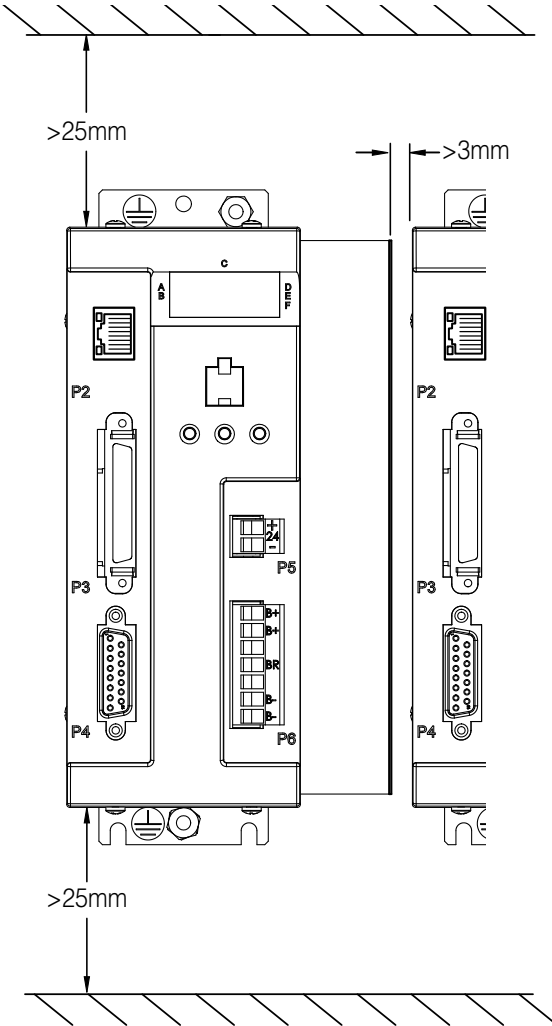

S924



Installation

3 Installation

Perform the minimum system connection. Please refer to section 6.1 for minimum connection requirements. Observe the rules and warnings below carefully:



DANGER!

Hazard of electrical shock! Circuit potentials are up to 480 VAC above earth ground. Avoid direct contact with the printed circuit board or with circuit elements to prevent the risk of serious injury or fatality. Disconnect incoming power and wait 60 seconds before servicing drive. Capacitors retain charge after power is removed.



STOP!

- The PositionServo must be mounted vertically for safe operation and to ensure enough cooling air circulation.
- Printed circuit board components are sensitive to electrostatic fields. Avoid contact with the printed circuit board directly. Hold the PositionServo by its case only.
- Protect the drive from dirt, filings, airborne particles, moisture, and accidental contact. Provide sufficient room for access to the terminal block.
- Mount the drive away from any and all heat sources. Operate within the specified ambient operating temperature range. Additional cooling with an external fan may be recommended in certain applications.
- Avoid excessive vibration to prevent intermittent connections
- DO NOT connect incoming (mains) power to the output motor terminals (U, V, W)! Severe damage to the drive will result.
- Do not disconnect any of the motor leads from the PositionServo drive unless (mains) power is removed. Opening any one motor lead may cause failure.
- Control Terminals provide basic isolation (insulation per EN 61800-5-1). Protection against contact can only be ensured by additional measures, e.g., supplemental insulation.
- Do not cycle mains power more than once every 2 minutes. Otherwise damage to the drive may result.



WARNING!

For compliance with EN 61800-5-1, the following warning applies.

This product can cause a d.c. current in the protective earthing conductor. Where a residual current-operated protective (RCD) or monitoring (RCM) device is used for protection in case of direct or indirect contact, only an RCD or RCM of Type B is allowed on the supply side of this product.



UL INSTALLATION INFORMATION

- Suitable for use on a circuit capable of delivering not more than 200,000 rms symmetrical amperes, at the maximum voltage rating marked on the drive.
- Use Class 1 wiring with minimum of 75°C copper wire only.
- Shall be installed in a pollution degree 2 macro-environment.



3.1 Wiring



DANGER!

Hazard of electrical shock! Circuit potentials are up to 480 VAC above earth ground. Avoid direct contact with the printed circuit board or with circuit elements to prevent the risk of serious injury or fatality. Disconnect incoming power and wait 60 seconds before servicing the drive. Capacitors retain charge after power is removed.



WARNING!

Leakage current may exceed 3.5mA AC. Minimum size of the protective earth conductor shall comply with local safety regulations for high leakage current equipment.



STOP!

Under no circumstances should power and control wiring be bundled together. Induced voltage can cause unpredictable behavior in any electronic device, including motor controls.

Refer to section 4.1.1 for power wiring specifications.

3.2 Shielding and Grounding

3.2.1 General Guidelines

Lenze recommends the use of single-point grounding (SPG) for panel-mounted controls. Serial grounding (a “daisy chain”) is not recommended. The SPG for all enclosures must be tied to earth ground at the same point. The system ground and equipment grounds for all panel-mounted enclosures must be individually connected to the SPG for that panel using 14 AWG (2.5 mm²) or larger wire.

In order to minimize EMI, the chassis must be grounded to the mounting. Use 14 AWG (2.5 mm²) or larger wire to join the enclosure to earth ground. A lock washer must be installed between the enclosure and ground terminal. To ensure maximum contact between the terminal and enclosure, remove paint in a minimum radius of 0.25 in (6 mm) around the screw hole of the enclosure.

Lenze recommends the use of the special PositionServo drive cables provided by Lenze. If you specify cables other than those provided by Lenze, please make certain all cables are shielded and properly grounded.

It may be necessary to earth ground the shielded cable. Ground the shield at both the drive end and at the motor end.

If the PositionServo drive continues to pick up noise after grounding the shield, it may be necessary to add an AC line filtering device and/or an output filter (between the drive and servo motor).



Installation

EMC

Compliance with EN 61800-3:2004

In a domestic environment this product may cause radio interference. The user may be required to take adequate measures

Noise emission

Drive Models ending in the suffix "2F" are in compliance with class A limits according to EN 55011 if installed in a control cabinet and the motor cable length does not exceed 10m. Models ending in "N" will require an appropriate line filter.

- A** Screen clamps
- B** Control cable
- C** Low-capacitance motor cable
(core/core < 75 pF/m, core/screen < 150 pF/m)
- D** Earth grounded conductive mounting plate
- E** Encoder Feedback Cable
- F** Footprint or Sidemount Filter (optional)

Installation according to EMC Requirements

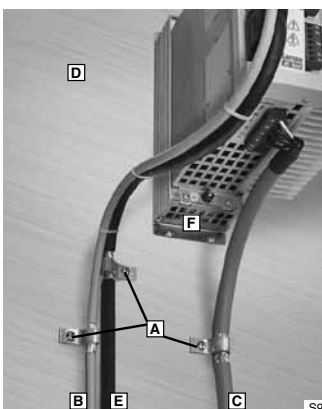

3.2.2 EMI Protection

Electromagnetic interference (EMI) is an important concern for users of digital servo control systems. EMI will cause control systems to behave in unexpected and sometimes dangerous ways. Therefore, reducing EMI is of primary concern not only for servo control manufacturers such as Lenze, but the user as well. Proper shielding, grounding and installation practices are critical to EMI reduction.

3.2.3 Enclosure

The panel in which the PositionServo is mounted must be made of metal, and must be grounded using the SPG method outlined in section 3.2.1.

Proper wire routing inside the panel is critical; power and logic leads must be routed in different avenues inside the panel.

You must ensure that the panel contains sufficient clearance around the drive. Refer to section 2.9 for the recommended cooling air clearance.



3.3 Line Filtering

In addition to EMI/RFI safeguards inherent in the PositionServo design, external filtering may be required. High frequency energy can be coupled between the circuits via radiation or conduction. The AC power wiring is one of the most important paths for both types of coupling mechanisms. In order to comply with IEC61800-3:2004, an appropriate filter must be installed within 20cm of the drive power inputs.

Line filters should be placed inside the shielded panel. Connect the filter to the incoming power lines immediately after the safety mains and before any critical control components. Wire the AC line filter as close as possible to the PositionServo drive.



NOTE

The ground connection from the filter must be wired to solid earth ground, not machine ground.

If the end-user is using a CE-approved motor, the AC filter combined with the recommended motor and encoder cables, is all that is necessary to meet the EMC directives listed herein. The end user must use the compatible filter to comply with CE specifications. The OEM may choose to provide alternative filtering that encompasses the PositionServo drive and other electronics within the same panel. The OEM has this liberty because CE requirements are for the total system.

3.4 Heat Sinking

The PositionServo drive contains sufficient heat sinking within the specified ambient operating temperature in its basic configuration. There is no need for additional heat sinking. However, the user must ensure that there is sufficient clearance for proper air circulation. As a minimum, an air gap of 25 mm above and below the drive is necessary.

3.5 Line (Mains) Fusing

External line fuses must be installed on all PositionServo drives. Connect the external line fuse in series with the AC line voltage input. Use fast-acting fuses rated for 250 VAC or 600 VAC (depending on model), and approximately 200% of the maximum RMS phase current. Refer to section 2.3 for fuse recommendations.



4 Interface

The standard PositionServo drive contains seven connectors: four quick-connect terminal blocks, one SCSI connector and one subminiature type “D” connector. These connectors provide communications from a PLC or host controller, power to the drive, and feedback from the motor. Prefabricated cable assemblies may be purchased from Lenze to facilitate wiring the drive, motor and host computer. Contact your Lenze Sales Representative for assistance.

As this manual makes reference to specific pins on specific connectors, we will use the convention PX.Y where X is the connector number and Y is the pin number.

4.1 External Connectors

4.1.1 P1 & P7 - Input Power and Output Power Connections

P1 is a 3 or 4-pin quick-connect terminal block used for input (mains) power. P7 is a 6-pin quick-connect terminal block used for output power to the motor. P7 also has a thermistor (PTC) input for motor over-temperature protection. The tables in this section identify the connector pin assignments.

**DANGER!**

Hazard of electrical shock! Circuit potentials are up to 480 VAC above earth ground. Avoid direct contact with the printed circuit board or with circuit elements to prevent the risk of serious injury or fatality. Disconnect incoming power and wait 60 seconds before servicing drive. Capacitors retain charge after power is removed.

**STOP!**

DO NOT connect incoming power to the output motor terminals (U, V, W)! Severe damage to the PositionServo will result.

Check phase wiring (U, V, W) and thermal input (T1, T2) before powering up drive. If miswired, severe damage to the PositionServo will result.

All conductors must be enclosed in one shield with a jacket around them. The shield on the drive end of the motor power cable should be terminated to the conductive machine panel using screen clamps as shown in section 3.2. The other end should be properly terminated at the motor shield. Feedback cable shields should be terminated in a like manner. Lenze recommends Lenze cables for both the motor power and feedback. These are available with appropriate connectors and in various lengths. Contact your Lenze representative for assistance.

Wire Size

Current A (rms)	Terminal Torque (lb-in)	Wire Size
$I \leq 8$	4.5	16 AWG (1.5mm ²) or 14 AWG (2.5mm ²)
$8 < I \leq 12$	4.5	14 AWG (2.5mm ²) or 12 AWG (4.0mm ²)
$12 < I \leq 15$	4.5	12 AWG (4.0mm ²)
$15 < I \leq 20$	5.0 - 7.0	10 AWG (6.0mm ²)
$20 < I \leq 24$	11.0 - 15.0	10 AWG (6.0mm ²)



P1 Pin Assignments (Input Power)

Pin	Standard Models		Doubler Models	
	Name	Function	Name	Function
1	PE	Protective Earth (Ground)	PE	Protective Earth (Ground)
2	L1	AC Power in	N	AC Power Neutral (120V Doubler only)
3	L2	AC Power in	L1	AC Power in
4	L3	AC Power in (3~ models only)	L2/N	AC Power in (non-doubler operation)

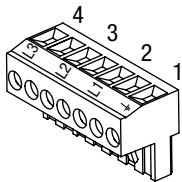

P7 Pin Assignments (Output Power)

Pin	Terminal	Function
1	T1	Thermistor (PTC) Input
2	T2	Thermistor (PTC) Input
3	U	Motor Power Out
4	V	Motor Power Out
5	W	Motor Power Out
6	PE	Protective Earth (Chassis Ground)

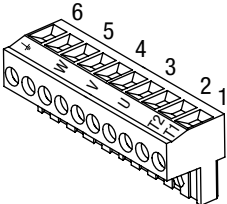

4.1.2 P2 - Ethernet Communications Port

P2 is a RJ45 Standard Ethernet connector that is used to communicate with a host computer via Ethernet TCP/IP.

P2 Pin Assignments (Communications)

Pin	Name	Function
1	+ TX	Transmit Port (+) Data Terminal
2	- TX	Transmit Port (-) Data Terminal
3	+ RX	Receive Port (+) Data Terminal
4	N.C.	
5	N.C.	
6	- RX	Receive Port (-) Data Terminal
7	N.C.	
8	N.C.	

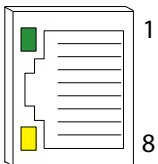

P2



NOTE

To communicate from the PC directly to the drive a crossover cable is required. If using a hub or switch, use a regular patch cable.



Interface

4.1.3 P3 - Controller Interface

P3 is a 50-pin SCSI connector for interfacing to the front-end of the controllers. It is strongly recommended that you use OEM cables to aid in satisfying CE requirements. Contact your Lenze representative for assistance.

P3 Pin Assignments (Controller Interface)

Pin	Name	Function	Connector
1	MA+	Master Encoder A+ / Step+ input ⁽²⁾	
2	MA-	Master Encoder A- / Step- input ⁽²⁾	
3	MB+	Master Encoder B+ / Direction+ input ⁽²⁾	
4	MB-	Master Encoder B- / Direction- input ⁽²⁾	
5	GND	Drive Logic Common	
6	5+	+5V output (max 100mA)	
7	BA+	Buffered Encoder Output: Channel A+ ⁽¹⁾	
8	BA-	Buffered Encoder Output: Channel A- ⁽¹⁾	
9	BB+	Buffered Encoder Output: Channel B+ ⁽¹⁾	
10	BB-	Buffered Encoder Output: Channel B- ⁽¹⁾	
11	BZ+	Buffered Encoder Output: Channel Z+ ⁽¹⁾	
12	BZ-	Buffered Encoder Output: Channel Z- ⁽¹⁾	
13-19		Empty	
20	AIN2+	Positive (+) of Analog signal input	
21	AIN2-	Negative (-) of Analog signal input	
22	ACOM	Analog common	
23	AO	Analog output (max 10 mA)	
24	AIN1+	Positive (+) of Analog signal input	
25	AIN1 -	Negative (-) of Analog signal input	
26	IN_A_COM	Digital input group ACOM terminal ⁽³⁾	
27	IN_A1	Digital input A1	
28	IN_A2	Digital input A2	
29	IN_A3	Digital input A3 ⁽³⁾	
30	IN_A4	Digital input A4	
31	IN_B_COM	Digital input group BCOM terminal	
32	IN_B1	Digital input B1	
33	IN_B2	Digital input B2	
34	IN_B3	Digital input B3	
35	IN_B4	Digital input B4	
36	IN_C_COM	Digital input group CCOM terminal	
37	IN_C1	Digital input C1	
38	IN_C2	Digital input C2	
39	IN_C3	Digital input C3	
40	IN_C4	Digital input C4	
41	RDY+	Ready output Collector	
42	RDY-	Ready output Emitter	
43	OUT1-C	Programmable output #1 Collector	
44	OUT1-E	Programmable output #1 Emitter	
45	OUT2-C	Programmable output #2 Collector	
46	OUT2-E	Programmable output #2 Emitter	
47	OUT3-C	Programmable output #3 Collector	
48	OUT3-E	Programmable output #3 Emitter	
49	OUT4-C	Programmable output #4 Collector	
50	OUT4-E	Programmable output #4 Emitter	

⁽¹⁾ See Note 1, Section 4.1.7 - Connector and Wiring Notes

⁽²⁾ See Note 2, Section 4.1.7 - Connector and Wiring Notes

⁽³⁾ See Note 3, Section 4.1.7 - Connector and Wiring Notes



4.1.4 P4 - Motor Feedback / Second Loop Encoder Input

For encoder-based 940 drives, P4 is a 15-pin DB connector that contains connections for an incremental encoder with Hall emulation tracks or Hall sensors. For synchronous servo motors, Hall sensors or Hall emulation tracks are necessary for commutation. If an asynchronous servo motor is used, it is not necessary to connect Hall sensor inputs. Encoder inputs on P4 have 26LS32 or compatible differential receivers for increased noise immunity. Inputs have all necessary filtering and line balancing components so no external noise suppression networks are needed.

For resolver-based 941 drives, P4 is a 9-pin DB connector for connecting resolver feedback and thermal sensor. For pin assignments, refer to the table P4B. The resolver feedback is translated to 65,536 counts per revolution.

All conductors must be enclosed in one shield with a jacket around them. Lenze recommends that each and every pair (for example, EA+ and EA-) be twisted. In order to satisfy CE requirements, use of an OEM cable is recommended.

The PositionServo buffers encoder/resolver feedback from P4 to P3. For example, when encoder feedback is used, channel A on P4, is Buffered Encoder Output channel A on P3. For more information on this refer to section 4.2.2 "Buffered Encoder Outputs".



STOP!

Use only +5 VDC encoders. Do not connect any other type of encoder to the PositionServo reference voltage terminals. When using a front-end controller, it is critical that the +5 VDC supply on the front-end controller NOT be connected to the PositionServo's +5 VDC supply, as this will result in damage to the PositionServo.



NOTE

- The PositionServo encoder inputs are designed to accept differentially driven hall signals. Single-ended or open-collector type hall signals are also acceptable by connecting "HA+", "HB+", "HC+" and leaving "HA-, HB-, HC-" inputs unconnected. The user does not need to supply pull-up resistors for open-collector hall sensors. The necessary pull-up circuits are already provided.
- Encoder connections (A, B and Z) must be full differential. The PositionServo does not support single-ended or open-collector type outputs from the encoder.
- An encoder resolution of 2000 PPR (pre-quadrature) or higher is recommended.

Using P4 as second encoder input for dual-loop operation:

P4 can be used as a second loop encoder input in situations where the motor is equipped with a resolver as the primary feedback. If such a motor is used, the drive must have a resolver feedback option module installed. A second encoder can then be connected to the A and B lines of the P4 connector for dual loop operation. Refer to section 6.4 ("Dual-loop Feedback Operation") for details.

P4A Pin Assignments (Encoder Feedback - E94P Drives)

Pin	Name	Function	Pin	Name	Function
1	EA+	Encoder Channel A+ Input ⁽¹⁾	9	PWR	Encoder supply (+5VDC)
2	EA-	Encoder Channel A- Input ⁽¹⁾	10	HA-	Hall Sensor A- Input ⁽²⁾
3	EB+	Encoder Channel B+ Input ⁽¹⁾	11	HA+	Hall Sensor A+ Input ⁽²⁾
4	EB-	Encoder Channel B- Input ⁽¹⁾	12	HB+	Hall Sensor B+ Input ⁽²⁾
5	EZ+	Encoder Channel Z+ Input ⁽¹⁾	13	HC+	Hall Sensor C+ Input ⁽²⁾
6	EZ-	Encoder Channel Z- Input ⁽¹⁾	14	HB-	Hall Sensor B- Input ⁽²⁾
7	GND	Drive Logic Common/Encoder GND	15	HC-	Hall Sensor C- Input ⁽²⁾
8	SHLD	Shield			

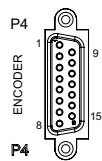

(1) See Note 1, Section 4.1.7 - Connector and Wiring Notes

(2) For asynchronous servo motor, an incremental encoder without Hall effect sensors (commutation tracks) can be used.



Interface

P4B Pin Assignments (Resolver Feedback - E94R Drives)

Pin	Name	Function
1	Ref +	Resolver reference connection
2	Ref -	
3	N/C	No Connection
4	Cos+	Resolver Cosine connections
5	Cos-	
6	Sin+	Resolver Sine connections
7	Sin-	
8	PTC+	Motor PTC Temperature Sensor
9	PTC-	

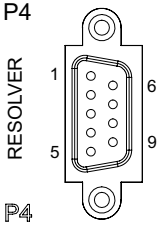

4.1.5 P5 - 24 VDC Back-up Power Input

P5 is a 2-pin quick-connect terminal block that can be used with an external 24 VDC (500mA) power supply to provide “Keep Alive” capability: during a power loss, the logic and communications will remain active. Applied voltage must be greater than 20VDC.

P5 Pin Assignments (Back-up Power)

Pin	Name	Function
1	+24 VDC	Positive 24 VDC Input
2	Return	24V power supply return



WARNING!

Hazard of unintended operation! The “Keep Alive” circuit will restart the motor upon restoration of mains power when the enable input remains asserted. If this action is not desired, then the enable input must be removed prior to re-application of input power.

4.1.6 P6 - Braking Resistor and DC Bus

P6 is a 5-pin quick-connect terminal block that can be used with an external braking resistor (the PositionServo has the regen circuitry built-in). The Brake Resistor connects between the Positive DC Bus (either P6.1 or 2) and P6.3.

P6 Terminal Assignments (Brake Resistor and DC Bus)

Pin	Terminal	Function
1	B+	Positive DC Bus / Brake Resistor
2	B+	
3	BR	Brake Resistor
4	B-	Negative DC Bus
5	B-	

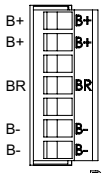

DANGER!

Hazard of electrical shock! Circuit potentials are up to 680 VAC above earth ground. Avoid direct contact with the printed circuit board or with circuit elements to prevent the risk of serious injury or fatality. Disconnect incoming power and wait 60 seconds before servicing the drive. Capacitors retain charge after power is removed.



4.1.7 Connector and Wiring Notes

Note 1 - Buffered Encoder Inputs

Each of the encoder output pins on P3 is a buffered pass-through of the corresponding input signal on P4. Refer to section 4.2.2 “Buffered Encoder Outputs”. This can be either from a motor mounted encoder/resolver, (primary feedback), or from an auxiliary encoder/resolver when an optional feedback module is used.

Via software, these pins can be re-programmed to be a buffered pass through of the signals from a feedback option card. This can be either the second encoder option module (E94ZAENC1) or an encoder emulation of the resolver connected to the resolver option module (E94ZARSV2 or E94ZARSV3).

Note 2 - Master Encoder Inputs or Step/Direction Inputs

An external pulse train signal (“step”) supplied by an external device, such as a PLC or stepper indexer, can control the speed and position of the servomotor. The speed of the motor is controlled by the frequency of the “step” signal, while the number of pulses that are supplied to the PositionServo determines the position of the servomotor. Direction input controls direction of the motion.

Note 3 - Digital Input A3

For the drive to function, an ENABLE input must be wired to the drive, and should be connected to IN_A3, (P3.29), which is, by the default the ENABLE input on the drive. This triggering mechanism can either be a switch or an input from an external PLC or motion controller. The input can be wired either sinking or sourcing (section 4.2.3). The Enable circuit will accept 5-24V control voltage.

Wiring the Enable Input:

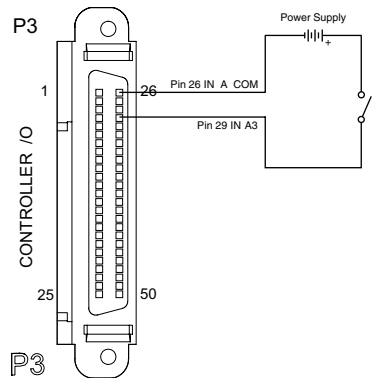
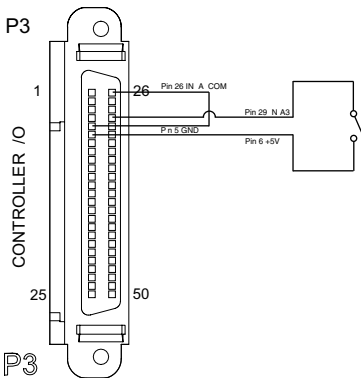



Interface

4.1.8 P11 - Resolver Interface Module (option)

PositionServo drives can operate motors equipped with resolvers from either the (P4) connection, for a resolver-based (E94R) drive, or from the Resolver option module for an encoder-based (E94P) drive. The option module connections are made to a 9 pin D-shell female connector (P11) on the resolver option module E94ZARSV2 (scalable) or E94ZARSV3 (standard). When the motor profile is loaded from the motor database or from a custom motor file, the drive will select the primary feedback source based on the motor data entry.

The E94ZARSV3 has a fixed resolution of 1024 PPR prequadrature or 4096 postquadrature. The E94ZARSV2 has a selectable set of 15 resolutions. The resolution refers to the pulses per revolution (PPR) of the Buffered Encoder Outputs (P3-7 to P3-12) if the Encoder Repeat Source is set as “Optional Feedback Input” in MotionView.

When using the E94ZARSV2, the default resolution is 1024 PPR prequadrature. Depending on the hardware/software revision of the E94ZARSV2 module, the available PPRs are different. Refer to the table below for the Dip Switch settings for SW1 and the different resolutions.

SW1 DIP Switch Settings

Dip Switch SW1				PPR prequadrature ⁽¹⁾	
Position 1	Position 2	Position 3	Position 4	Hardware/Software Revision ⁽²⁾ 1A10, 1A11, 1B11, 1C11	Hardware/Software Revision ⁽²⁾ 1C12 and higher
OFF	OFF	OFF	OFF	250	1024 (default)
OFF	OFF	OFF	ON	256	256
OFF	OFF	ON	OFF	360	360
OFF	OFF	ON	ON	400	400
OFF	ON	OFF	OFF	500	500
OFF	ON	OFF	ON	512	512
OFF	ON	ON	OFF	720	720
OFF	ON	ON	ON	800	800
ON	OFF	OFF	OFF	1000	1000
ON	OFF	OFF	ON	1024 (default)	1024 (default)
ON	OFF	ON	OFF	2000	2000
ON	OFF	ON	ON	2048	2048
ON	ON	OFF	OFF	2500	2500
ON	ON	OFF	ON	2880	2880
ON	ON	ON	OFF	4096	250
ON	ON	ON	ON	4096	4096

(1) For PPR postquadrature, multiply by 4.

(2) Hardware/Software Revision can be found on the dataplate label attached to the plastic cover of the module. For example, the revision in the example below is 1B11.

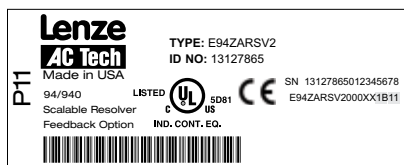



Setting the Dip Switches

To change the DIP SWITCH SETTING

1. Loosen the three set screws on the module
2. Detach the PCB board from the plastic cover
3. Change the SW1 positions according to the table above
4. Put the PCB board back in the plastic cover
5. Tighten the three set screws

When using a Lenze motor with resolver feedback and a Lenze resolver cable, the pins are already configured for operation. If a non-Lenze motor is used, the resolver connections are made as follows:

P11 Pin Assignments (Resolver Feedback)

Pin	Name	Function
1	Ref +	Resolver reference connection
2	Ref -	
3	N/C	No Connection
4	Cos+	Resolver Cosine connections
5	Cos-	
6	Sin+	Resolver Sine connections
7	Sin-	
8	PTC+	Motor PTC Temperature Sensor
9	PTC-	

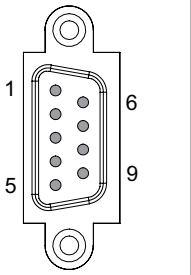

STOP!

Use only 10 V (peak to peak) or less resolvers. Use of higher voltage resolvers may result in feedback failure and damage to the resolver option module.

4.1.9 P12 - Second Encoder Interface Module (option)

PositionServo drives can support a second incremental encoder interface for dual-loop systems. Regardless of whether the motor's primary feedback type is an encoder or resolver, a 2nd Encoder Option Module, E94ZAENC1, can be installed at Option Bay 2, (P12). Once installed the optional feedback card can be selected as the primary encoder repeat source from the "Parameter" folder in MotionView. The 2nd Encoder Option Module includes a 9 pin D-shell male connector. When using a Lenze motor with encoder feedback and a Lenze encoder cable, the pins are already configured for operation. If a non-Lenze motor is used, the encoder connections are made as follows:

P12 Pin Assignments (Second Encoder Feedback)

Pin	Name	Function
1	E2B+	Second Encoder Channel B+ Input
2	E2A-	Second Encoder Channel A- Input
3	E2A+	Second Encoder Channel A+ Input
4	+5v	Supply voltage for Second Encoder
5	COM	Supply common
6	E2Z-	Second Encoder Channel Z- Input
7	E2Z+	Second Encoder Channel Z+ Input
8	N/C	No Connection
9	E2B-	Second Encoder Channel B- Input

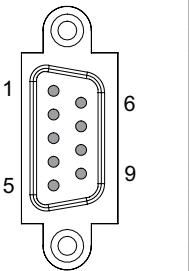

The second encoder needs to be enabled using MotionView software. (section 6.4).



STOP!

Use only +5 VDC encoders. Do not connect any other type of encoder to the option module. Otherwise, damage to drive's circuitry may result.



4.2 Digital I/O Details

4.2.1 Step & Direction / Master Encoder Inputs (P3, pins 1-4)

You can connect a master encoder with quadrature outputs or a step and direction pair of signals to control position in step / direction operating mode (stepper motor emulation). These inputs are optically isolated from the rest of the drive circuits and from each other. Both inputs can operate from any voltage source in the range of 5 to 24 VDC and do not require additional series resistors for normal operation.

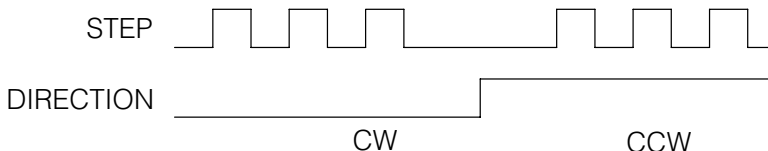

Timing characteristics for Step And Direction signals

S904

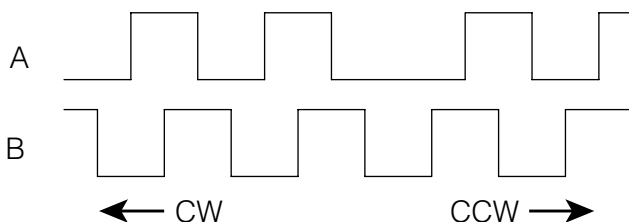

S905

Timing characteristics for Master Encoder signals

Input type/ output compatibility	Insulated, compatible with Single-ended or differential outputs (5-24 VDC)
Max frequency (per input)	2 MHz
Min pulse width (negative or positive)	500nS
Input impedance	700 Ω (approx)

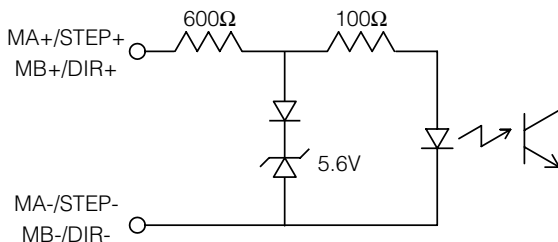

S906

Master encoder/step and direction input circuit

Differential signal inputs are preferred when using Step and Direction. Single ended inputs can be used but are not recommended. Sinking or sourcing outputs may also be connected to these inputs. The function of these inputs “Master Encoder” or “Step and Direction” is software selectable. Use the MotionView set up program to choose the desirable function.



4.2.2 Buffered Encoder Output (P3, pins 7-12)

There are many applications where it is desired to close the feedback loop to an external device. This feature is built into the PositionServo drive and is referred to as the “Buffered Encoder Output”. If a motor with encoder feedback is being used, the A+, A-, B+, B-, Z+ and Z- signals are directly passed through the drive through pins 7-12 with no delays, up to a speed of 25MHz. If a motor with resolver feedback is being used a simulated encoder feedback is transmitted. The default resolution of the simulated encoder is 1024 pulses per revolution, pre-quad. If a different resolution is desired refer to section 5.3.22 “Resolver Tracks”.

4.2.3 Digital Outputs

There are a total of five digital outputs (“OUT1” - “OUT4” and “RDY”) available on the PositionServo drive. These outputs are accessible from the P3 connector. Outputs are open collector type that are fully isolated from the rest of the drive circuits. See the following figure for the electrical diagram. These outputs can be either used via the drives internal User Program or they can be configured as Special Purpose outputs. When used as Special Purpose, each output (OUT1-OUT4) can be assigned to one of the following functions:

- Not assigned
- Zero speed
- In-speed window
- Current limit
- Run-time fault
- Ready
- Brake (motor brake release)

Please note that if you assign an output as a Special Purpose Output then that output can not be utilized by the User Program. The “RDY” Output has a fixed function, “ENABLE”, which will become active when the drive is enabled and the output power transistors becomes energized.

Digital outputs electrical characteristics

Circuit type	Isolated Open Collector
Digital outputs load capability	15mA
Digital outputs Collector-Emitter max voltage	30V

The inputs on drive can be wired as either sinking (NPN) or sourcing (PNP), as illustrated in wiring examples mb101 and mb102.

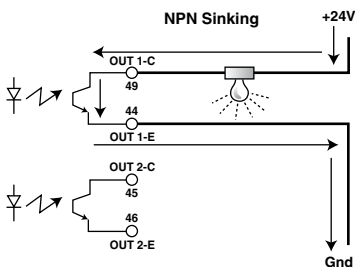

mb101

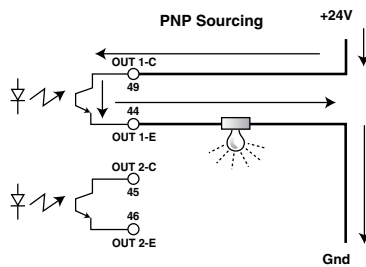

mb102



Interface

4.2.4 Digital Inputs

IN_Ax, IN_Bx, IN_Cx (P3.26-30, P3.31-35, P3.36-40)

The PositionServo Drive has 12 optically isolated inputs. These inputs are compatible with a 5 - 24V voltage source. No additional series resistors are needed for circuit operation. The 12 inputs are segmented into three groups of 4, Inputs A1 - A4, Inputs B1 - B4, and Inputs C1 - C4. Each group, (A, B and C) have their own corresponding shared common, (ACOM, BCOM and CCOM). Each group or bank can be wired as sinking or sourcing. Refer to wiring examples mb103 and mb104. All inputs have a separate software adjustable de-bounce time. Some of the inputs can be set up as Special Purpose Inputs. For example inputs A1 and A2 can be configured as limit inputs, input A3 is always set up as an Enable input and input C3 can be used as a registration input. Refer to the PositionServo Programming Manual (PM94P01) for more detail.

For the registration input (C3), the registration time is $3\mu\text{s}$ for an encoder and $7\mu\text{s}$ for a resolver.

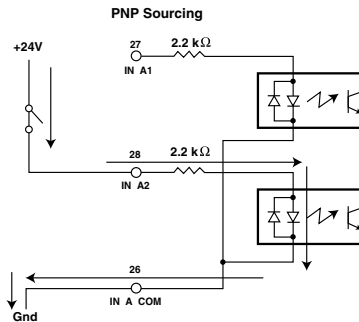

Digital inputs circuit.

mb103

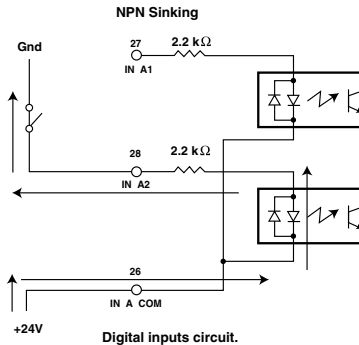

Digital inputs circuit.

mb104



4.3 Analog I/O Details

4.3.1 Analog Reference Input

AIN1+, AIN1- (P3.24 and P3.25)

The analog reference input can accept up to a $\pm 10\text{V}$ analog signal across AIN1+ and AIN1-. The maximum limit with respect to analog common (ACOM) on each input is $\pm 18\text{VDC}$. The analog signal will be converted to a digital value with 16 bit resolution (15 bit plus sign). This input is used to control speed or torque of the motor in velocity or torque mode. The total reference voltage as seen by the drive is the voltage difference between AIN1+ and AIN1-. If used in single-ended mode, one of the inputs must be connected to Analog Common (ACOM). If used in differential mode, the voltage source is connected across AIN1+ and AIN1- and the driving circuit common (if any) needs to be connected to the drive Analog Common (ACOM) terminal. Refer to wiring examples mb105 and mb106.

Reference as seen by drive: $V_{ref} = (AIN1+) - (AIN1-)$ and $-10\text{V} \leq V_{ref} \leq +10\text{V}$

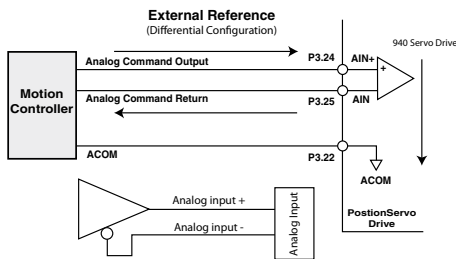

mb105

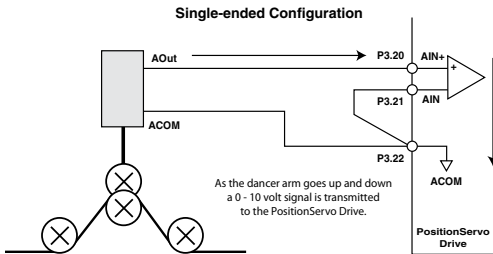

mb106

AIN2+, AIN2- (P3.20 and P3.21)

The analog reference input can accept up to a $\pm 10\text{V}$ analog signal across AIN2+ and AIN2-. The maximum limit with respect to analog common (ACOM) on each input is $\pm 18\text{VDC}$. The analog signal will be converted to a digital value with 10 bit resolution (9 bit plus sign). This input is available to the User's program. This input does not have a predefined function. Scaling of this input is identical to AIN1.



Interface

4.3.2 Analog Output

AO (P3.23)

The analog output is a single-ended signal (with reference to Analog Common (ACOM)) which can represent the following motor data:

- Not Assigned
- Phase R Current
- Phase S Current
- Phase T Current
- Motor Velocity
- Iq Current
- Id Current

Motor phase U, V and W corresponds to R, S and T respectively.

MotionView Setup program can be used to select the signal source for the analog output as well as its scaling.

If the output function is set to “Not Assigned” then the output can be controlled directly from user’s program. Refer to the PositionServo Programming Manual (PM94P01) for programming details.



STOP!

Upon application of power to the PositionServo, the Analog Output supplies -10VDC until bootup is complete. Once bootup is complete, the Analog Output will supply the commanded voltage.

4.4 Communication Interfaces

4.4.1 Ethernet Interface (standard)

Programming and diagnostics of the drive are performed over the standard Ethernet communication port. The Drives IP address can be displayed from the drive’s front panel display. The last octet of the drive’s IP address can be set from the drive’s display. Changes do not take affect until after a power cycle. The interface supports both 100 BASE-TX as well as 10 BASE-T. This configuration allows the user to monitor and program multiple drives from MotionView. Refer to section 5.4.1 for PC configuration information.

4.4.2 RS485 Interface (option)

PositionServo drives can be equipped with an RS485 communication interface option module (E94ZARS41) which is optically isolated from the rest of the drive’s circuitry. This option module can be used for two functions: drive programming and diagnostics using MotionView from a PC (with RS485 port) or as a Modbus RTU slave. The PositionServo drives support 5 different baud rates, ranging from 9600 to 115200. Drives are addressable with up to 32 addresses from 0-31. The factory setting for the baud rate is 38,400 with a node address of “1”. The drives address must be set from the front panel display of the drive. When used with MotionView software, the communication speed is also set from the front panel display. If used for Modbus RTU communications, the Modbus baud rate is set as a parameter within MotionView.

Pin Assignments (RS485 interface)

Pin	Name	Function
1	ICOM	Isolated Common
2	TXB	Transmit B(+)
3	TXA	Transmit A(-)

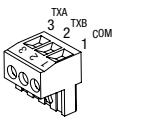



4.4.3 RS485 Communication Setup

When establishing communication between MotionView and a PositionServo drive, a communication method must be selected. The connection choice can be either “UPP over RS485/RS232” or “Ethernet”. The “UPP over RS485/RS232” selection establishes a RS485 connection between MotionView and the first drive on the network. Multiple drives can then be added to the network via RS485. Each drive on the network must have a different Node Address. When setting up communications the node address of the target drive must be set. MotionView will then send out a communications packet to the drives on the network, via the RS485 connection. The message, “Device with address # not present in the network” will appear if the target node could not be found.

4.4.4 MODBUS RTU Support

As a default, the Ethernet and RS485 interfaces are configured to support MotionView program operations. In addition, the Ethernet port can support MODBUS TCP/IP slave protocols and the RS485 interface can be configured to support the MODBUS RTU slave protocol. These interfaces are configured through the MotionView program environment. When configured for MODBUS operation, the baud rate for RS485 is set by the parameter “Modbus baud rate” in MotionView. MODBUS RTU requires 8 data bits. The MODBUS RTU slave interface protocol definitions can be found in the MotionView help menu under “Product Manuals”.

4.4.5 CAN Interface (option)

An optional CANopen communication module (E94ZACAN1) is available for the PositionServo drive. Installed in Option Bay 1 as P21, the CANopen module is optically isolated from the rest of the drive’s circuitry. The 3-pin CANopen module is for HW/SW 1A10 and the 5-pin CANopen module is for HW/SW 1B10 or higher. Refer to the PS CANopen Reference Guide (P94CAN01) for more information.

CANopen Interface Pin Assignments

3-Terminal	Pin	Name	Function	Pin	Name	Function	5-Terminal
	1	ICOM	Isolated Common	1	ICOM	Isolated Common	
	2	CAN L	CAN Bus Low	2	CAN L	CAN Bus Low	
	3	CAN H	CAN Bus High	3	Shield		
				4	CAN H	CAN Bus High	
				5	NC	No connection	

4.5 Motor Selection

The PositionServo drive is compatible with many 3-phase AC synchronous servo motors as well as 3-phase AC asynchronous servo motors. MotionView is equipped with a motor database that contains over 600 motors for use with the PositionServo drive. If the desired motor is in the database, no data to set it up is needed. Just select the motor and click “OK”. However, if your motor is not in the database, it can still be used, but some electrical and mechanical data must be provided to create a custom motor profile. The auto-phasing feature of the PositionServo drive allows the user to correctly determine the relationship between phase voltage and hall sensor signals, eliminating the need to use a multi-channel oscilloscope.

4.5.1 Motor Connection

Motor phase U, V, W (or R, S, T) are connected to terminal P7. It is very important that motor cable shield is connected to Earth ground terminal (PE) or the drive’s case. The motor’s encoder/resolver feedback cable must be connected to terminal P4. If a resolver option module is used, connect to terminal P11, and if a second encoder option module is used, connect to terminal P12.



Interface

4.5.2 Motor Over-temperature Protection

If using a motor equipped with an encoder and PTC thermal sensor, the encoder feedback cable will have flying leads exiting the P4 connector to be wired to the P7.1 (T1) and P7.2 (T2) terminals. If using a motor equipped with a Resolver and a PTC sensor, the thermal feedback is passed directly to the drive via the resolver 9-pin D shell connector.

Use parameter “Motor PTC cut-off resistance” (refer to section 5.3.12) to set the resistance that corresponds to maximum motor allowed temperature. The parameter “Motor temperature sensor” must also be set to ENABLE. If the motor doesn’t have a PTC sensor, set this parameter to DISABLE. This input will also work with N.C. thermal switches which have only two states; Open or Closed. In this case “Motor PTC cut-off resistance” parameter can be set to the default value.

4.5.3 Motor Setup

Once you are connected to the PositionServo via MotionView a “Parameter Tree” will appear in the “Parameter Tree Window”. The various parameters of the drive are shown here as folders and files. If the “Motor” folder is selected, all motor parameters can be viewed in the “Parameter View Window”. To view selected motor parameters or to select a new motor click the section marked “CLICK HERE TO CHANGE”.



S911

MotionView’s “Motor Group” folder and its contents



NOTE

If the drive is ENABLED, a new motor cannot be set. You can only set a new motor when the drive is DISABLED.

To View selected motor parameters or to make a new motor selection:

- Click “Click here to change the motor” from the Parameter View Window (see figure above). If just viewing the motor parameters click Cancel on the Motor Parameters dialog box when done to dismiss the box.
- Select motor Vendor from the right list box and desired motor from the left list box.
- If you will be using a “custom” motor (not listed in our motor database) go to “Using a custom motor” topic in the next section.
- Finally, click the OK button to dismiss the dialog box and return to MotionView’s main program.



NOTE

To help prevent the motor from drawing too much current and possibility overheating it is recommended that the drives “Current Limit” be checked against the motors “Nominal Phase Current” and set accordingly.



4.6 Using a Custom Motor

You can load a custom motor from a file or you can create a new custom motor.

- To create a custom motor click “CREATE CUSTOM” and follow the instructions in the next section “Creating custom motor parameters”.
- To load a custom motor click “OPEN CUSTOM” button then select the motor file and click the “OPEN” button to select or click the “CANCEL” button to return to the previous dialog box.
- Click OK to load the motor data and return to the main MotionView menu or Cancel to abandon changes. When clicking OK for a custom motor, a dialog box will appear asking if you want to execute “Autophasing” (refer to section 4.6.2).

4.6.1 Creating Custom Motor Parameters



STOP!

Use extreme caution when entering custom parameters! Incorrect settings may cause damage to the drive or motor! If you are unsure of the settings, refer to the materials that were distributed with your motor, or contact the motor manufacturer for assistance.

1. Enter custom motor data in the Motor Parameters dialog fields. Complete all sections of dialog: Electrical, Mechanical, Feedback. Refer to section 4.6.3 for explanation of motor parameters and how to enter them.



NOTE

If unsure of the motor halls order and encoder channels A and B relationship, leave “B leads A for CW”, “Halls order” and “inverted” fields as they are. You can execute autophasing (refer to section 4.6.2) to set them correctly.

2. Enter motor model and vendor in the top edit boxes. Motor ID cannot be entered, this is set to 0 for custom motors.
3. Click “Save File” button and enter filename without extension. Default extension .cmt will be given when you click OK on file dialog box.



NOTE

Saving the file is necessary even if the autophasing feature will be used and some of the final parameters are not known. After autophasing is completed the corrected motor file can be updated before loading it to memory.

4. Click OK to exit from the Motor Parameters dialog.
5. MotionView will ask if you want to autophase your custom motor. If you answer “No”, the motor data will be loaded immediately to the drive’s memory. If you answer “Yes”, the motor dialog will be dismissed and the drive will start the autophasing sequence. Refer to section 4.6.2 for autophasing information.
6. If you answered “Yes” for autophasing, you will be returned to the same motor selection dialog box after autophasing is complete. For motors with incremental encoders, the fields “B leads A for CW”, “Halls order” and “inverted” will be assigned correct values. For motors with resolvers, the fields “Offset in degree” and “CW for positive” will be assigned correct values.
7. Click “Save File” to save the custom motor file and then click “OK” to exit the dialog box and load the data to the drive.



4.6.2 Autophasing

The Autophasing feature determines important motor parameters when using a motor that is not in MotionView's database. For motors equipped with incremental encoders, Autophasing will determine the Hall order sequence, Hall sensor polarity and encoder channel relationship (B leads A or A leads B for CW rotation). For motors equipped with resolvers, Autophasing will determine resolver angle offset and angle increment direction ("CW for positive").

To perform autophasing:

1. Complete the steps in the previous section "Setting custom motor parameters". If the motor file you are trying to autophase already exists, simply load it as described under "Using a custom motor" at the beginning of this section.
2. Make sure that the motor's shaft is not connected to any mechanical load and can freely rotate.



STOP!

Autophasing will energize the motor and will rotate the shaft. Make sure that the motor's shaft is not connected to any mechanical load and can freely and safely rotate.

3. Make sure that the drive is not enabled.

4. It is not necessary to edit the field "Hall order" and check boxes "inverted" and "B leads A for CW" as these values are ignored for autophasing.
5. Click OK to dismiss motor selection dialog. MotionView responds with the question "Do you want to perform autophasing?"
6. Click OK. A safety reminder dialog appears. Verify that it is safe to run the motor then click "Proceed" and wait until autophasing is completed.



NOTE

If there is a problem with the motor connection, hall sensor connection or resolver connection, MotionView will respond with an error message. Problems commonly occur with power, shield and ground terminations or when an improper cable is used. Correct the wiring problem(s) and repeat steps 1 - 6.

If the error message repeats, exchange motor phases U and V (R and S) and repeat. If problems persist, contact the factory.

7. If autophasing is completed with no error then MotionView will return to the motor dialog box. For motors with incremental encoders, the parameter field "Hall order" and the check boxes "inverted", "B leads A for CW" will be filled in with correct values. For resolver equipped motors, fields "Offset" and "CW for positive" will be correctly set.
8. Click "Save File" to save the completed motor file (you can use the same filename as you use to save initial data in step 1) and click OK to load the motor data to the drive.

4.6.3 Custom Motor Data Entry

A Custom Motor file is created by entering motor data into the "Motor Parameters" dialog box. This box is divided up into the following three sections, or frames:

- Electrical constants
- Mechanical constants
- Feedback

When creating a custom motor you must supply all parameters listed in these sections. All entries are mandatory except the motor inertia (Jm) parameter. A value of 0 may be entered for the motor inertia if the actual value is unknown.



4.6.3.1 Electrical constants

Motor Torque Constant (Kt)

Enter the value and select proper units from the drop-down list.



NOTE

Round the calculated result to 3 significant places.

Motor Voltage Constant (Ke)

The program expects Ke to be entered as a phase-to-phase Peak voltage. If you have Ke as an RMS value, multiply this value by 1.414 for the correct Ke Peak value.

Phase-to-phase winding Resistance (R) in Ohms

This is also listed as the terminal resistance (Rt). The phase-to-phase winding Resistance (R) will typically be between 0.05 and 200 Ohms.

Phase-to-phase winding Inductance (L)

This must be set in millihenries (mH). The phase-to-phase winding Inductance (L) will typically be between 0.1 and 200.0 mH.



NOTE

If the units for the phase-to-phase winding Inductance (L) are given in micro-henries (μH), then divide by 1000 to get mH.

Nominal phase current (RMS Amps)

Nominal continuous phase current rating (I_n) in Amps RMS. Do not use the peak current rating.



NOTE

Sometimes the phase current rating will not be given. The equation below may be used to obtain the nominal continuous phase-to-phase winding current from other variables.

$$I_n = \text{Continuous Stall Torque} / \text{Motor Torque Constant (Kt)}$$

The same force x distance units must be used in the numerator and denominator in the equation above. If torque (T) is expressed in units of pound-inches (lb-in), then Kt must be expressed in pound-inches per Amp (lb-in/A). Likewise, if T is expressed in units of Newton-meters (N-m), then units for Kt must be expressed in Newton-meters per Amp (N-m/A).

Example:

Suppose that the nominal continuous phase to phase winding current (I_n) is not given. Instead, we look up and obtain the following:

Continuous stall torque T = 3.0 lb-in

Motor torque constant Kt = 0.69 lb-in/A

Dividing, we obtain:

$$I_n = 3.0 \text{ lb-in} / 0.69 \text{ lb-in/A} = 4.35 \text{ (A)}$$

Our entry for (I_n) would be 4.35.

Note that the torque (lb-in) units are cancelled in the equation above leaving just Amps (A). We would have to use another conversion factor if the numerator and denominator had different force x distance units.



Interface

Nominal Bus Voltage (Vbus)

The Nominal Bus Voltage can be calculated by multiplying the Nominal AC mains voltage supplied by 1.41. When using a model with the suffix "S1N" where the mains are wired to the "Doubler" connection, the Nominal Bus Voltage will be doubled.

Example:

If the mains voltage is 230VAC, $V_{bus} = 230 \times 1.41 = 325V$

This value is the initial voltage for the drive and the correct voltage will be calculated dynamically depending on the drive's incoming voltage value.

Rotor Moment of Inertia (Jm)

From motor manufacturer or nameplate.



NOTE

Round the calculated result to 3 significant places.

Maximum Motor Speed in RPM

This is also listed as "Speed @ Vt" (motor speed at the terminal voltage rating). The maximum motor speed will typically be a round even value between 1000 - 6000 RPM.

Number of Poles

This is a positive integer number that represents the number of motor poles, normally 2, 4, 6 or 8.

4.6.3.2 For Incremental Encoder - Equipped Motors Only

Encoder Line Count

The Encoders for servomotors normally have Line Counts of 1000, 1024, 2000, 2048, 4000, or 4096. The Encoder Line Count must be a positive integer and must be pre-quadrature.

Index pulse offset. Enter 0 (zero)

Index marker pulse position. This field is reserved for backward compatibility. All PositionServo drives determine actual marker pulse position automatically.

Halls Order

Each hall signal is in phase with one of the three phase-phase voltages from the motor windings. Hall order number defines which hall sensor matches which phase-phase voltage. Motor phases are usually called R-S-T or U-V-W or A-B-C. Phase-Phase voltages are called V_{rs} , V_{st} , V_{tr} . Halls are usually called HALL-A, HALL-B, HALL-C or just Halls 1, 2, 3. A motor's phase diagram is supplied by motor vendor and usually can be found in the motor data sheet or by making a request to the motor manufacturer. A sample phase diagram is illustrated in Figure S912.

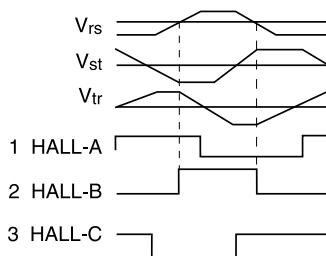

S912



The Halls Order is obtained as follows:

1. Look at the “Vrs” Output Voltage and determine the Hall Voltage that is lined up with (or in phase with) this voltage. To determine which Hall Voltage is in phase with the Vrs Output Voltage draw vertical lines at those points where it crosses the horizontal line (zero). The dashed lines at the zero crossings (above) indicate that Hall B output is lined up with (and in phase with) the Vrs Output Voltage.
2. Look at the “Vst” Output Voltage. Determine which Hall Voltage is in phase with this Voltage. Per Figure S912, the Hall C output is in phase with the Vst Output Voltage.
3. Look at the “Vtr” Output Voltage. Determine which Hall Voltage is in phase with this Voltage. Per Figure S912, the Hall A output is in phase with the Vtr Output Voltage.



NOTE

If hall sensors are in phase with the corresponding phase voltage but are inverted 180 degrees (hall sensor waveform edge aligns with the phase-phase voltage waveform but the positive hall sensor cycle matches the negative phase-phase waveform or visa-versa), you must check the “Inverted” check box.

4. The phases that correspond to the Vrs, Vst and Vtr voltages are Hall B then Hall C then Hall A or Halls number 2 then 3 then 1. Referring to the following table, we find that 2-3-1 sequence is Halls Order number 3. We would then enter 3 for the Halls Order field in the motor dialog box.

Hall Order Numbers for Different Hall Sequences

Halls Order	Hall Sequence
0	1-2-3
1	1-3-2
2	2-1-3
3	2-3-1
4	3-1-2
5	3-2-1



NOTE

Each Hall Voltage is in phase with one and only one Output Voltage.

B leads A for CW

This is the encoder phase relationship for CW/CCW shaft rotation. When you obtain the diagram for your motor phasing similar to shown above, it's assumed by the software that the motor shaft rotates CW when looking at the mounting face of the motor. For that rotation Encoder phase A must lead phase B. If it does leave the check box unchecked. Otherwise (if B leads A), check B leads A in the CW box.



NOTE

Lenze convention references the shaft direction of rotation from the front (shaft end) of the motor. Some manufacturer's timing diagrams are CW when viewed from the “rear” of the motor.



Interface

4.6.3.3 For Resolver Equipped Motors Only

If parameter “Resolver” is checked, following parameters appear on the form:

Offset in degree (electrical)

This parameter represents offset between resolver’s “0 degree” and motor’s windings “0 degree”.

CW for positive

This parameter sets the direction for positive angle increment.

“Offset in degree” and “CW for positive” will be set during Auto-Phasing of the motor.

4.6.3.4 For Asynchronous Servo Motors Only

Four additional parameters need to be defined for asynchronous motors:

Power Factor Cos Phi (cos ϕ)

The power factor is defined as the ratio of the active (true or real) power to apparent power. The power factor range is from 0 to 1.

Base Frequency in Hz

The motor base frequency defines the output frequency, when operating at rated voltage, rated current, rated speed, and rated temperature.

Velocity Nominal in RPM

Also called rated velocity or speed, velocity nominal is obtained when the motor is operated at the base frequency, rated current, rated voltage, and rated temperature.

Velocity Max in RPM

This is the maximum speed of the motor. The maximum velocity is usually limited by mechanical construction.



5 Parameters

The PositionServo drive is configured through an RS485 or Ethernet interface. The drive has many programmable features and parameters accessible via a universal software called MotionView. Refer to the MotionView Manual for details on how to make a connection to the drive and change parameter values. This chapter covers the PositionServo's programmable features and parameters in the order they appear in the Parameter Tree of MotionView. Programmable parameters are divided into groups. Each group holds one or more user adjustable parameters.

All drives can execute a User Program in parallel with motion. Motion can be specified by variety of sources and in three different modes: Torque, Velocity and Position.

In Torque and Velocity mode Reference can be taken from Analog Input AIN1 or from the User Program by setting a particular variable (digital reference). In Position mode, the reference could be taken from MA/MB master encoder/step and directions inputs (available in terminal P3) or from trajectory generator. Access to the trajectory generator is provided through the User Program's motion statements, MOVE_x and MDV. Refer to the PositionServo Programming Manual for details on programming.

Whether the reference comes from an external device, (AIN1 or MA/MB) or from the drives internal variables (digital reference and trajectory generator) will depend on the parameter settings. Refer to "Parameters" group in MotionView.

5.1 Parameter Storage and EPM Operation

5.1.1 Parameter Storage

All settable parameters are stored in the drive's internal non-volatile memory. Parameters are saved automatically when they are changed and are copied to the EPM memory module located on the drive's front panel. In the unlikely event of drive failure, the EPM can be removed and inserted into the replacement drive, thus making an exact copy of the drive being replaced. This shortens down time by eliminating the configuration procedure. The EPM can also be used for replication of the drive's settings.

5.1.2 EPM Operation

When the drive is powered up it first checks for a white EPM in the EPM Port. If the EPM Port is empty, no further operation is possible until a white EPM is installed into the EPM Port. The drive will display "--EP--" until an EPM is inserted. Never install or remove the EPM module while the drive is powered.

If a different color EPM is inserted the drive may appear to function however, some operations will not be correct and the drive may hang. The white EPM is the only acceptable EPM for the PositionServo drive. If a white EPM is detected, the drive compares data in the EPM to that in its internal memory. In order for the drive to operate, the contents of the drive's memory and EPM must be the same. If "FEP?" is displayed press the enter button to load the EPM's data to the drive. Wait. The drive will display "BUSY" during loading and will return to normal display once the update is completed.

**STOP!**

If the EPM contains any data from an inverter drive, that data will be overwritten during this procedure.

5.1.3 EPM Fault

If the EPM fails during operation or the EPM is removed from the EPM Port, the drive will generate a fault and will be disabled (if enabled). The fault is logged to the drives fault history. Further operation is not possible until the EPM is replaced (inserted) and the drive's power is cycled. The fault log on the display shows "F_EP" fault.



5.2 Motor Group

The motor group shows the data for the currently selected motor. Refer to section 4.5 for details on how to select another motor from the motor database or to configure a custom motor.

5.3 Parameters

5.3.1 Drive Operating Modes

The PositionServo has 3 operating mode selections: Torque, Velocity and Position.

For Torque and Velocity modes the drive will accept an analog input voltage on the AIN1+ and AIN1- pins of P3 (refer to section 4.3.1). This voltage is used to provide a torque or speed reference.

For Position mode the drive will accept step and direction logic signals or a quadrature pulse train on pins P3.1- P3.4.

5.3.1.1 Torque Mode

In torque mode, the servo control provides a current output proportional to the analog input signal at input AIN1, if parameter "Reference" is set to "External". Otherwise the reference is taken from the drive's internal variable, IREF. (Refer to the PositionServo Programming Manual for details). For analog reference "Set Current", (current the drive will try to provide), is calculated using the following formula:

$$\text{Set Current(A)} = \text{Vinput(Volt)} \times \text{Iscale (A/Volt)}$$

where: Vinput is the voltage at analog input

Iscale is the current scale factor (input sensitivity) set by the Analog input (Current Scale) parameter (section 5.3.5).

5.3.1.2 Velocity Mode

In velocity mode, the servo controller regulates motor shaft speed (velocity) proportional to the analog input voltage at input AIN1, if parameter "Reference" is set to "External". Otherwise the reference is taken from the drive's internal variable, IREF. (Refer to the PositionServo Programming Manual for details). For analog reference, Target speed (set speed) is calculated using the following formula:

$$\text{Set Velocity (RPM)} = \text{Vinput (Volt)} \times \text{Vscale (RPM/Volt)}$$

where: Vinput is the voltage at analog input (AIN1+ and AIN1-)

Vscale is the velocity scale factor (input sensitivity) set by the Analog input (Velocity scale) parameter (section 5.3.6).

5.3.1.3 Position Mode

In this mode the drive reference is a pulse-train applied to P3.1-4 terminals, if the parameter "Reference" is set to "External". Otherwise the reference is taken from the drive's internal variables. (Refer to the PositionServo Programming Manual for details).

P3.1-4 inputs can be configured for two types of signals: step and direction and Master encoder quadrature signal. Refer to section 4.2.1 for details on these inputs connections. Refer to section 6.3 for details about positioning and gearing.

When the Reference is set to Internal, the drives reference position, (theoretical or Target position), is generated by trajectory generator. Access to the trajectory generator is provided by motion statements, MOVEx and MDV, from the User Program.



5.3.2 Drive PWM frequency

This parameter sets the PWM carrier frequency. Frequency can be changed only when the drive is disabled. Maximum overload current is 300% of the drive rated current when the carrier is set to 8kHz. It is limited to 250% at 16kHz.

5.3.3 Current Limit

The CURRENT LIMIT setting determines the nominal currents, in amps RMS per phase, which output to the motor phases. To prevent the motor from overloading, this parameter is usually set equal to the motor nominal (or rated) phase current. If MotionView (6.04) or higher is used, the Current Limit is set equal to the nominal motor phase current by default when a motor model is selected. To modify this parameter, refer to section 5.3.23.

5.3.4 Peak Current Limit (8 kHz and 16 kHz)

Peak Current Limit sets the motor RMS phase current that is allowed for up to 2 seconds. After this two second limit, the drive output current to motor will be reduced to the value set by the Current Limit parameter. When the motor current drops below nominal current for two seconds, the drive will automatically re-enable the peak current level. This technique allows for high peak torque on demanding fast moves and fast start/stop operations with high regulation bandwidth. If 8 kHz is used for Drive PWM frequency, use the parameter 8 kHz Peak Current Limit, otherwise, use 16 kHz Peak Current Limit.

If MotionView (6.04) or higher is used, the Peak Current Limit is set equal to 2.5 times the nominal motor phase current by default when a motor model is selected. To prevent motor from overloading, the Peak Current Limit shall be set no higher than the maximum motor current. Otherwise, the motor may be damaged due to overheating. To modify this parameter, refer to section 5.3.23.

5.3.5 Analog Input Scale (current scale)

This parameter sets the analog input sensitivity for current reference used when the drive operates in torque mode. Units for this parameter are A/Volt. To calculate this value use the following formula:

$$I_{scale} = I_{max} / V_{in\ max}$$

I_{max} maximum desired output current (motor phase current RMS)

$V_{in\ max}$ max voltage fed to analog input at I_{max}

Example:

$$\begin{aligned} I_{max} &= 5A \text{ (phase RMS)} \\ V_{in\ max} &= 10V \\ I_{scale} &= I_{max} / V_{in\ max} \\ &= 5A / 10V = 0.5 A / \text{Volt (value to enter)} \end{aligned}$$

5.3.6 Analog Input Scale (velocity scale)

This parameter sets the analog input sensitivity for the velocity reference used when the drive operates in velocity mode. Units for this parameter are RPM/Volt. To calculate this value use the following formula:

$$V_{scale} = VELOCITY_{max} / V_{in\ max}$$

$VELOCITY_{max}$ maximum desired velocity in RPM

$V_{in\ max}$ max voltage fed to analog input at $Velocity_{max}$

Example:

$$\begin{aligned} VELOCITY_{max} &= 2000 \text{ RPM} \\ V_{in\ max} &= 10V \\ V_{scale} &= VELOCITY_{max} / V_{in\ max} \\ &= 2000 / 10V \\ &= 200 \text{ RPM / Volt (value to enter)} \end{aligned}$$



5.3.7 ACCEL/DECEL Limits (velocity mode only)

The ACCEL setting determines the time the motor takes to ramp to a higher speed. The DECEL setting determines the time the motor takes to ramp to a lower speed. If the ENABLE ACCEL/DECEL LIMITS is set to DISABLE, the drive will automatically accelerate and decelerate at maximum acceleration limited only by the current limit established by the PEAK CURRENT LIMIT and CURRENT LIMIT settings.

5.3.8 Reference

The REFERENCE setting selects the reference signal being used by the drive. This reference signal can be either External or Internal. An External Reference can be one of three types, an Analog Input signal, a Step and Direction Input or an Input from an external Master Encoder. The Analog Input reference is used when the drive is either in torque or velocity mode. The Master Encoder and Step and Direction reference is used when the drive is in position mode. An Internal Reference is used when the motion being generated is derived from drive's internal variable(s), i.e., User Program, (Refer to the PositionServo Programming Manual).

5.3.9 Step Input Type (position mode only)

This parameter sets the type of input for position reference the drive expects to see. Signal type can be step and direction (S/D) type or quadrature pulse-train (Master Encoder / Electronic Gearing). Refer to section 4.2.1 for details on these inputs.

5.3.10 Fault Reset Option

The FAULT RESET OPTION selects the type of action required to reset the drive after a FAULT signal has been generated by the drive. ON DISABLE clears the fault when the drive is disabled. This is useful if you have a single drive and motor connected in a single drive system. The ON ENABLE option clears the fault when the drive is re-enabled. Choose ON ENABLE if you have a complex servo system with multiple drives connected to an external controller. This makes troubleshooting easier since the fault will not be reset until the drive is re-enabled. Thus, a technician can more easily determine which component of a complex servo system has caused the fault.

5.3.11 Motor Temperature Sensor

This parameter enables / disables motor over-temperature detection. It must be disabled if the motor PTC sensor is not wired to either P7.1-2 or to the resolver option module (P11).

5.3.12 Motor PTC Cut-off Resistance

This parameter sets the cut-off resistance of the PTC which defines when the motor reaches the maximum allowable temperature. See section 4.5.2 for details how to connect motor's PTC.

5.3.13 Second Encoder

Disables or enables second encoder. Effectively selects single-loop or double-loop configuration in position mode. The second encoder connects to the Encoder Option Module (E94ZAENC1) connector P12, refer to section 6.4 for details on dual loop operation.



5.3.14 Regeneration Duty Cycle

This parameter sets the maximum duty cycle for the brake (regeneration) resistor. This parameter can be used to prevent brake resistor overload. Use the following formula to calculate the maximum value for this parameter. If this parameter is set equal to the calculated value, the regeneration resistor is most effective without overload. One may set this parameter with a value smaller than the calculated one if the drive will not experience over voltage fault during regeneration.

$$D = P * R / (U_{max})^2 * (1/D_{application}) * 100\%$$

Where:

D (%) regeneration duty cycle

U_{max} (VDC) bus voltage at regeneration conditions

U_{max} = 390 VDC for 120/240 VAC drives and 770 VDC for 400/480 VAC drives.

R (Ohm) regeneration resistor value

P (W) regeneration resistor rated power

D_{application} (%) application duty cycle. For the continuous regeneration applications, use D_{application} = 1. For the intermittent regeneration applications, use D_{application} = t/T, where t is the duration when regeneration is needed and T is the time interval between two regenerations. Both t and T must use the same time unit, e.g., seconds

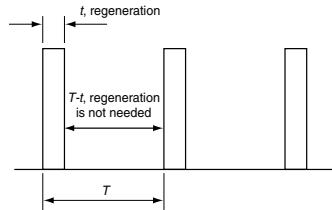

If calculation of D is greater than 100% set it to 100% value. If calculation of D is less than 10% then resistor power rating is too low. For more information refer to the PositionServo Dynamic Braking Manual (G94BR01).

Minimum Required Dynamic Braking Resistance

Drive Model	DB Resistor Minimum Resistance (Ω)
E94_180T2N~~	15
E94_080S2F~~, E94_080Y2N~~, E94_100S2F~~, E94_100Y2N~~	20
E94_120Y2N	30
E94_020S1N~~, E94_020S2F~~, E94_020Y2N~~, E94_040S1N~~, E94_040S2F~~, E94_040Y4N~~	40
E94_090T4N~~	45
E94_040T4N~~, E94_050T4N~~, E94_060T4N~~	75
E94_020T4N~~	150



Parameters

5.3.15 Encoder Repeat Source

This parameter sets the feedback source signal for the buffered encoder outputs (P3.7 -P3.12). The source can be the drive's feedback input (P4) or an optional feedback module (resolver, second encoder etc.)

5.3.16 System to Master Ratio

This parameter is used to set the scale between the reference pulse train (when operating in position mode) and the system feedback device. In a single loop configuration, the system feedback device is the motor encoder or resolver. In a dual-loop system the system encoder is the second encoder. See sections 6.3 and 6.4 for details.

5.3.17 Second to Prime Encoder Ratio

This parameter sets the ratio between the secondary encoder and the primary feedback device when the drive is configured to operate in dual-loop mode. When the primary feedback device is a resolver, the pulse count is fixed at 65,536. The resolutions of encoders are "post quadrature" (PPR x 4). See section 6.4.



NOTE

Post quadrature pulse count is 4X the pulses-per-revolution (PPR) of the encoder.

5.3.18 Autoboot

When set to "Enabled" the drive will start to execute the user's program immediately after cold boot (reset). Otherwise the user program has to be started from MotionView or from the Host interface.

5.3.19 Group ID

Refer to the PositionServo Programming Manual for details. This parameter is only needed for operations over Ethernet network.

5.3.20 Enable Switch Function

If set to "Run", input IN_A3 (P3.29) acts as an "Enable" input when the user program is not executing. If the user program is executing, the function will always be "Inhibit" regardless of the setting. This parameter is needed so the drive can be Enabled/Disabled without running a user's program.

5.3.21 User Units

This parameter sets up the relationship between User Units and motor revolutions. From here you can determine how many User Units there is in one motor revolution. This parameter allows the user to scale motion moves to represent a desired unit of measure, (inches, meters, in/sec, meters/sec, etc). For example: A linear actuator allows a displacement of 2.5" with every revolution of the motor's shaft.

Units = Units / Revolutions

Units = 2.5 Inches / Revolution

Units = 2.5

5.3.22 Resolver Track

The Resolver Track parameter is used in conjunction with the resolver motors and Buffered Encoder Outputs, (section 4.2.2). If a motor with resolver feedback is being used a simulated encoder feedback is transmitted out the Buffered Encoder Outputs, P3.7 to P3.12. The default resolution of this feedback is 1024 pulses per revolution, pre quad. If a different resolution is required then the Resolver Track parameter is utilized.



The number entered into this field, 0-15, directly correlates to a different encoder resolution. Please reference the table herein.

Resolver Track Configuration

Resolver Track	Resolution Before Quad	Resolver Track	Resolution Before Quad
0	1024	8	1000
1	256	9	1024
2	360	10	2000
3	400	11	2048
4	500	12	2500
5	512	13	2880
6	720	14	250
7	800	15	4096

5.3.23 Current Limit Max Overwrite

If this parameter is set to “Disable”, the parameters “Current limit”, “8 kHz peak current limit” and “16 kHz peak current limit” cannot be overwritten. If you want to overwrite the above three current limit parameters, this parameter must be set as “Enable”. To prevent the motor from overloading, the “current limit”, “8 kHz peak current limit” and “16 kHz peak current limit” shall be set to values no higher than the corresponding current limits of the motor in use. Note that this parameter applies to firmware version (3.06) or higher.

5.4 Communication

5.4.1 Ethernet Interface

Programming and diagnostics of the PositionServo drive are done over the standard 10/100 Mbps Ethernet communication port. All devices on an Ethernet network have an IP address. Before connecting MotionView software to the PositionServo drive, set up the IP address of the drive and configure the PC as well.

The IP address of the PositionServo drive is composed of four sub-octets that are separated by three dots. This conforms to the Class C Subnet structure. The sub-octets IP_1, IP_2, IP_3 and IP_4 can be found by using “UP” and “DOWN” buttons of the LED panel and are organized in the following order:

IP_1.IP_2.IP_3.IP_4

where each sub-octet IP_x can be any number between 1-254. On the LED display, only IP_4 can be changed. IP_1, IP_2 and IP_3 can be changed once the PositionServo drive is connected to the MotionView software. As shipped from the factory the default IP address is 192.168.124.120.

If using the default PC Ethernet port on your computer for internal use (email, web browsing, etc.) AC Tech recommends that you add an additional Ethernet port to your PC. The most common and cost effective way to do this is by using a USB / Ethernet dongle or a PCMCIA Ethernet card. Then configure this Ethernet port to the PositionServo Subnet address and leave your local connection for your internal use.

There are two modes to obtain the IP address of the PositionServo drive by setting DHCP equal to either 0 or 1. These modes are described herein. It is important to know that the drive must be rebooted after changing any Ethernet settings such as IP address and DHCP.



Parameters

5.4.1.1 Manually Obtain the PositionServo Drive's IP Address

The PositionServo drive can be connected to a local PC or a private network if setting DHCP=0. In this mode, make sure to set DHCP = 0 via the diagnostic display LED, refer to section 7.1 for details. One can also verify the IP address of the drive via the display LED. When shipped from the factory the default IP address of the PositionServo drive is 192.168.124.120. Before MotionView can establish communications to the drive, both the PC and the PositionServo drive must be on the same subnet, but have different addresses. That is, both the PC and PositionServo drive shall have the same sub-octets IP_1, IP_2 and IP_3 and different IP_4. When connecting MotionView to a brand-new PositionServo drive out of box, set the PC's IP address as 192.168.124.1. Refer to section 6.4.1.3 on how to set up your PC IP address. Every time dHCP, or any IP sub-octet IP_x is changed, one must reboot the PositionServo drive so that the change can take effect.

Once the MotionView software is connected to the PositionServo drive, one can change the DHCP setting and the drive IP address via the communication option "Ethernet" – "IP setup" in MotionView. If one wants to configure the PositionServo drive's IP address under a specific subnet, for example, 10.135.110.xxx as shown below. One can pick an available IP_4, e.g., 246 is used below, then click "OK" to confirm. After this change, make sure to reboot the drive. After the drive reboot, the IP address stored in the EPM before last power-off will be the drive's IP address. In the meantime, one needs to configure the PC's IP address under the same subnet. In case, one may choose "Obtain an IP Address Automatically" for the PC or pick up an available IP address, refer to section 5.4.1.3 for details.



5.4.1.2 Automatically Obtain the PositionServo's IP Address

To use this mode set dHCP = 1 via the diagnostic display LED (refer to section 7.1 for details). After setting this parameter, cycle the input power to the PositionServo drive so that the setting can take effect. The LED display will be "----" if one checks the IP address octets IP_1, IP_2, IP_3 and IP_4. This means that the drive is still trying to acquire an IP address from the dHCP server. To obtain the PositionServo drive's IP address automatically, there must be a dHCP server available.

5.4.1.3 Set the PC's IP Address

Follow these steps to set up the PC's IP address:

To display the IP address of your PC, from the Start menu, select "Control Panel" and then select "Network Connections".



Select the connection you wish to set: “Local Area Connection”, the PC Default Port or “Local Area Connection x” your additional Ethernet port. Then double-click the icon to open the [Connection Status] details. To view the connection properties click the [Properties] button.

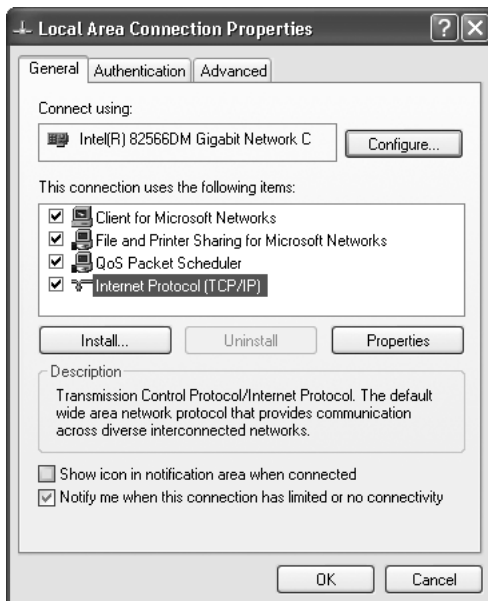

Select [Internet Protocol (TCP/IP)] and click the [Properties] button.



Parameters



Select “Use the following IP address” and enter [192.168.124.1] for the IP address. Now enter the subnet mask [255.255.255.0], and then click the [OK] button. Note that one can use “Obtain an IP address automatically” after the PositionServo drive’s IP address has been configured under the same subnet to which the PC is connected.

5.4.2 RS-485 Configuration

This parameter sets how the optional RS485 interface will function. The RS485 interface can be configured for normal operation (programming and diagnostics using MotionView software) or as a Modbus RTU slave. Refer to section 4.4 for details on communication interfaces.

5.4.3 Modbus Baud Rate

This parameter sets the baud rate for RS485 interface in Modbus RTU mode. When the drive is operating in normal mode the baud rate is set to the same setting as the RS232 interface.

5.4.4 Modbus Reply Delay

This parameter sets the time delay between the drives reply to the Modbus RTU master. This delay is needed for some types of Modbus masters to function correctly.

5.5 Analog I/O

5.5.1 Analog Output

The PositionServo has one analog output with 10-bit resolution on P3 pin 23. The signal is scaled to $\pm 10V$. The analog output can be assigned to following functions:

- Not Assigned
- Phase current RMS
- Phase current Peak
- Motor Velocity
- Phase R current
- Phase S current
- Phase T current
- Iq current (Torque component)
- Id current (Direct component)



5.5.2 Analog Output Current Scale (Volt / amps)

Applies scaling to all functions representing CURRENT values.

5.5.3 Analog Output Current Scale (mV/RPM)

Applies scaling to all functions representing VELOCITY values. (Note: that mV/RPM scaling units are numerically equivalent to volts/kRPM).

5.5.4 Analog Input Dead Band

Allows the setting of a voltage window (in mV) at the reference input AIN1+ and AIN1- (P3 pins 24 and 25) such that any voltage within that window will be treated as zero volts. This is useful if the analog input voltage drifts resulting in motor rotation when commanded to zero.

5.5.5 Analog Input Offset Parameter

Allows you to adjust the offset voltage at AIN1+ and AIN1- (P3 pins 24 and 25). This function is equivalent to the balance trim potentiometer found in analog drives. Lenze recommends that this adjustment be made automatically using the “Adjust analog voltage offset” button while the external analog reference signal commands zero speed.

5.5.6 Adjust Analog Input Zero Offset

This control button is useful to allow the drive to automatically adjust the analog input voltage offset. To use it, command the external reference source input at AIN1+ and AIN1- (P3 pins 24 and 25) to zero volts and then click this button. Any offset voltage at the analog input will be adjusted out and the adjustment value will be stored in the “Analog input offset” parameter.

5.6 Digital I/O

The PositionServo has four digital outputs. These outputs can be either assigned to one of the following functions, or be used by the drives internal User Program

- **Not Assigned** No special function assigned. Output can be used by the User Program.
- **Zero Speed** Output activated when drive is at zero speed, refer to “Velocity Limits” (section 5.7) for settings.
- **In Speed Window** Output activated when drive is in set speed window, refer to “Velocity Limits” (section 5.7) for settings.
- **Current Limit** Output activated when drive detects current limit.
- **Run Time Fault** A fault has occurred. Refer to section 8.3 for details on faults.
- **Ready** Drive is enabled.
- **Brake** Command for the holding brake option (E94ZAHBK2) for control of a motor with a holding brake. This output is active 10ms after the drive is enabled and deactivates 10ms before the drive is disabled.
- **In position** Position mode only. Refer to the Programming Manual.

5.6.1 Digital Input De-bounce Time

Sets de-bounce time for the digital inputs to compensate for bouncing of the switch or relay contacts. This is the time during an input transition that the signal must be stable before it is recognized by the drive.



5.6.2 Hard Limit Switch Action

Digital inputs IN_A1 and IN_A2 can be used as limit switches if their function is set to “Fault” or “Stop and Fault”. Activation of these inputs while the drive is enabled will cause the drive to Disable and go to a Fault state. The “Stop and Fault” action is available only in Position mode when the “Reference” parameter is set to “Internal”, i.e., when the source for the motion is the Trajectory generator. Refer to the PositionServo Programming Manual for details on “Stop and Fault” behavior. IN_A1 is the negative limit switch. IN_A2 is the positive limit switch. Both are treated as normally open.

5.7 Velocity Limits

These parameters are active in Velocity Mode Only.

5.7.1 Zero Speed

Specifies the upper threshold for motor zero speed in RPM. When the motor shaft speed is at or below the specified value the zero speed condition is set to true in the internal controller logic. The zero speed condition can also trigger a programmable digital output, if selected.

5.7.2 Speed Window

Specifies the speed window width used with the “In speed window” output.

5.7.3 At Speed

Specifies the speed window center used with the “In speed window” output.

These last two parameters specify speed limits. If motor shaft speed is within these limits then the condition AT SPEED is set to TRUE in the internal controller logic. The AT SPEED condition can also trigger a programmable digital output, if selected. For example if “AT SPEED” is set for 1000 RPM, and the “SPEED WINDOW” is set for 100, then “AT SPEED” will be true when the motor velocity is between 950 -1050 RPM.

5.8 Position Limits

5.8.1 Position Error

Specifies the maximum allowable position error in the primary (motor mounted) feedback device before enabling the “Max error time” clock. When using an encoder, the position error is in post-quadrature encoder counts. When using a resolver, position error is measured at a fixed resolution of 65,536 counts per motor revolution.

5.8.2 Max Error Time

Specifies maximum allowable time (in mS) during which a position error can exceed the value set for the “Position error” parameter before a Position Error Excess fault is generated.

5.8.3 Second Encoder Position Error

Specifies the maximum allowable error of the second encoder in post quadrature encoder counts before enabling the “Second encoder max error time” clock.

5.8.4 Second Encoder Max Error Time

Specifies maximum allowable time (in mS) during which the second encoder’s position error can exceed the value set for the “Second encoder position error” parameter before a Position Error Excess fault is generated.



5.9 Compensation

5.9.1 Velocity P-gain (proportional)

Proportional gain adjusts the system's overall response to a velocity error. The velocity error is the difference between the commanded velocity of a motor shaft and the actual shaft velocity as measured by the primary feedback device. By adjusting the proportional gain, the bandwidth of the drive is more closely matched to the bandwidth of the control signal, ensuring more precise response of the servo loop to the input signal.

5.9.2 Velocity I-gain (integral)

The output of the velocity integral gain compensator is proportional to the accumulative error over cycle time, with I-gain controlling how fast the error accumulates. Integral gain also increases the overall loop gain at the lower frequencies, minimizing total error. Thus, its greatest effect is on a system running at low speed, or in a steady state without rapid or frequent changes in velocity.

**NOTE**

The following four position gain settings are only active if the drive is operating in Position mode. They have no effect in Velocity or Torque modes.

5.9.3 Position P-gain (proportional)

Position P-gain adjusts the system's overall response to position error. Position error is the difference between the commanded position of the motor shaft and the actual shaft position. By adjusting the proportional gain, the bandwidth of the drive is more closely matched to the bandwidth of the control signal, ensuring more precise response of the servo loop to the input signal.

5.9.4 Position I-gain (integral)

The output of the Position I-gain compensator is proportional to accumulative error over cycle time, with I-gain controlling how fast the error accumulates. Integral gain also increases overall loop gain at the lower frequencies, minimizing total error. Thus, its greatest effect is on a system running at low speed, or in a steady state without rapid or frequent changes in position.

5.9.5 Position D-gain (differential)

The output of the Position D-gain compensator is proportional to the difference between the current position error and the position error measured in the previous servo cycle. D-gain decreases the bandwidth and increases the overall system stability. It is responsible for removing oscillations caused by load inertia and acts similar to a shock-absorber in a car.

5.9.6 Position I-limit

The Position I-limit will clamp the Position I-gain compensator to prevent excessive torque overshooting caused by an over accumulation of the I-gain. It is defined in terms of percent of maximum drive velocity. This is especially helpful when position error is integrated over a long period of time.



Parameters

5.9.7 Gain Scaling Window

Sets the total velocity loop gain multiplier (2^n) where n is the velocity regulation window. If, during motor tuning, the velocity gains become too small or too large, this parameter is used to adjust loop sensitivity. If the velocity gains are too small, decrease the total loop gain value, by decreasing this parameter. If gains are at their maximum setting and you need to increase them even more, use a larger value for this parameter.

5.10 Tools

5.10.1 Oscilloscope Tool

The oscilloscope tool gives real time representation of different signals inside the PositionServo drive and is helpful when debugging and tuning drives. Operation of the oscilloscope tool is described in greater detail in the MotionView User's Manual (IM94MV01). The following signals can be observed with the oscilloscope tool:

Phase Current (RMS):	Motor phase current
Phase Current (Peak):	Motor peak current
Iq Current:	Measures the motor Iq (torque producing) current
Motor Velocity:	Actual motor speed in RPM
Commanded Velocity:	Desired motor speed in RPM (velocity mode only)
Velocity Error:	Difference in RPM between actual and commanded motor speed
Position Error:	Difference between actual and commanded position (Step & Direction mode only)
Bus Voltage:	DC bus voltage
Analog Input:	Voltage at drive's analog input
Absolute Position:	Absolute (actual) position
Absolute Position Pulses:	Absolute position expressed in pulses of the primary feedback device
Secondary Abs Position:	Absolute (actual) position of secondary feedback device
Secondary Position Error:	Difference between actual and commanded position of secondary feedback device
Target Position:	Requested position
Target Position Pulses:	Requested position expressed in pulses of the primary feedback device
Position Increment:	Commanded position increment

5.10.2 Run Panels

Check Phasing

This button activates the Autophasing feature as described in section 4.6.2. However, in this panel only the motor phasing is checked, the motor data is not modified.

5.11 Faults

The Faults Group loads the fault history from the drive. The 8 most recent faults are displayed with the newer faults replacing the older faults in a first-in, first-out manner. In all cases fault # 0 is the most recent fault. To clear the faults history from the drive's memory click on the "Reset Fault history" button. Each fault has its code and explanation of the fault. Refer to section 8.3 for details on faults.



6 Operation

This section offers guidance on configuring the PositionServo drive for operations in torque, velocity or position modes without requiring a user program. To use advanced programming features of PositionServo please perform all steps below and then refer to the PositionServo Programming Manual for details on how to write motion programs.

6.1 Minimum Connections

For the most basic operation, connect the PositionServo to mains (line) power at terminal P1, the servomotor power at P7 and the motor feedback as appropriate.



DANGER!

Hazard of electrical shock! Circuit potentials are up to 480 VAC above earth ground. Avoid direct contact with the printed circuit board or with circuit elements to prevent the risk of serious injury or fatality. Disconnect incoming power and wait at least 60 seconds before servicing drive. Capacitors retain charge after power is removed.

As a minimum these connections must be made:

- Connect an Ethernet crossover cable between PositionServo's P2 and your PC's Ethernet port. A straight patch cable can be used if using a hub or switch.
- Connect mains power to terminal P1. Mains power must be as defined on the drive's data label (section 2.1).
- When connecting to an encoder-based drive, take the encoder feedback cable and connect it to the 15 pin D-sub connector located at P4. When connecting to a resolver-based drive, take the resolver feedback cable and connect it to the 9 pin D-sub connector located at P4.
- Connect motor windings U, V, W (also known as R, S, T) to terminal P7 according to Section 4.1.1. Make sure that motor cable shield is connected as described in section 3.2.
- Provide an Enable switch (IN_A3) according to Section 6.5.
- Perform drive configuration as described in the next section.



Note

When using an encoder-based drive and operating with a resolver option module as the primary feedback, a second encoder can be connected to P4.

6.2 Configuration of the PositionServo

The PositionServo must first be configured for the specific motor that will be used, the mode of operation, and then any additional features that will be used.

Drive configuration consists of following steps:

- Motor Selection
- Mode of operation selection
- **Reference source selection (Very Important)**
- Drive parameters (i.e. current limit, acceleration / deceleration) setup
- Operational limits (velocity or position limits) setup
- Input / Output (I/O) setup
- Velocity / position compensator (gains) setup
- Optionally store drive settings in a PC file and exit the MotionView program.

Operation

To configure drive:

1. Ensure that the control is properly installed and mounted. Refer to section 4 for installation instructions.
2. Perform wiring to the motor and external equipment suitable for desired operating mode and your system requirements.
3. Connect the Ethernet port P2 on the drive to your PC Ethernet port. If connecting directly to the drive from the PC, a crossover cable is required.
4. Make sure that the drive is disabled.
5. Apply power to the drive and wait until “d rS” shows on the display. For anything other than this, refer to the chart below before proceeding.

Drive Display	Meaning
-EP-	EPM missing. Refer to 6.1.2
EPi	EPM data. Refer to 6.1.2
----	No valid firmware
----	Monitor mode

6. Confirm that the PC and the drive have the correct IP setting. Refer to section 5.4.1.1 - Setting Your PC IP Address.
7. Launch MotionView software on your computer.
8. From the MotionView menu, select <Project> <Connection setup>.
9. Select “Ethernet UDP”, then click the OK button.
10. From the MotionView menu, select <Node> <Connect Drive>.
11. Click the Discover button to ping the network for any drives. If a drive is located the address will appear on the screen. If no address appears then you can type the IP address in. The default address for the drive is 192.168.124.120. Click the Connect button to connect to the drive.
12. Once MotionView connects to the drive, its node icon will appear in the upper left-hand corner of the Parameter Tree Window. Refer to the PositionServo Programming Manual for more details.



Note

MotionView’s “Connection setup” properties need only be configured the first time MotionView is operated or if the port connection is changed. Refer to MotionView User’s Manual for details on how to make a connection to the drive.

13. Double-click on the drive’s icon to expand parameter group’s folders.
14. Select the motor to be used according to the section 4.5.
15. Expand the folder “Parameters” and choose the operating mode for the drive. Refer to section 5.3.1 for details on operating modes.
16. Click on the “Current limit” parameter, refer to section 5.3.3 and enter current limit (in Amp RMS per phase) appropriate for the motor.
17. Click on the appropriate “Peak current limit” parameter, refer to section 5.3.4, based on the “Drive PWM frequency” parameter, refer to section 5.3.2, used and enter the peak current limit (in Amps RMS per phase) appropriate for your motor.
18. Set up additional parameters suitable for the operating mode selected in step 17.
19. After you configure the drive, proceed to the tuning procedure if operating in “Velocity”, or “Position” mode. “Torque” mode doesn’t require additional tuning or calibration. Refer to section 6.6 for details on tuning.



6.3 Position Mode Operation (gearing)

In position mode the drive will follow the master reference signals at the 1-4 inputs of P3. The distance the motor shaft rotates per each master pulse is established by the ratio of the master signal pulses to motor encoder pulses (in single loop configuration). The ratio is set by “System to Master ratio” parameter (see section 5.3.16).

Example 1

Problem: Setup the drive to follow a master encoder output where 1 revolution of the master encoder results in 1 revolution of the motor

Given: Master encoder: 4000 pulses/revolution (post quadrature)
 Motor encoder: 8000 pulses/revolution (post quadrature)

Solution: Ratio of System (motor encoder) to Master Encoder is $8000/4000 = 2/1$
 Set parameter “System to master ratio” to 2:1

Example 2

Problem: Setup drive so motor can follow a master encoder wheel where 1 revolution of the master encoder results in 3 revolutions of the motor

Given: Motor encoder: 4000 pulses/revolution (post quadrature)
 Master encoder: 1000 pulses/revolution (post quadrature).
 Desired “gear ratio” is 3:1

Solution: Ratio is motor encoder PPR divided by master encoder PPR times the “gear ratio”:
 $(\text{Motor PPR} / \text{Master PPR}) * (3/1) \Rightarrow (4000/1000) * (3/1) \Rightarrow 12/1$
 Set parameter “System to master ratio” to 12:1

6.4 Dual-loop Feedback

In dual-loop operation (position mode only) the relationship between the Master input and mechanical system movement requires that two parameters be set:

1. “System to master ratio” sets the ratio between the second encoder pulses (system encoder) and the master input pulses.
2. “Prime to second encoder ratio” sets the ratio between the second and primary (motor) encoder. If the motor is equipped with a resolver connected to the resolver option module, the primary encoder resolution of 65536 (post quadrature) must be used.

When operating in this mode the second encoder input is applied to integral portion of the position compensator. Therefore it is important that the Position I-gain and Position I-limit parameters are set to non 0 values. Always start from very small values of Position I-limit values.



Note

When using an encoder-based drive and operating with the Resolver Option Module as the primary feedback, a second encoder can be connected to P4.

6.5 Enabling the PositionServo

Regardless of the selected operating mode, the PositionServo must be enabled before it can operate. A voltage in the range of 5-24 VDC connected between P3 pins 26 and 29 (input IN_A3) is used to enable the drive, refer to section 4.1.7, note 3. The behavior of input IN_A3 differs depending on the setting of “Enable switch function”.



TIP!

If using the onboard +5VDC power supply for this purpose, wire your switch between pins P3.6 and P3.29. Jumper P3.5 to P3.26. If doing this, all inputs in group A must be powered by P3.6.

When the “Enable switch function” is set to “RUN”:

IN_A3 acts as positive logic ENABLE or negative logic INHIBIT input depending on:

If user program is not running: Activating IN_A3 enables the drive
 User program running: Activating IN_A3 acts as negative logic “Inhibit” and operates exactly as if parameter “Enable switch function” set to “Inhibit” (see below)

When the “Enable switch function” set to “Inhibit”:

IN_A3 acts as negative logic INHIBIT input regardless of mode or program status.

Activating input IN_A3 doesn't enable the drive. The drive can be enabled from the user's program or interface only when IN_A3 is active. Attempt to enable drive by executing the program statement “ENABLE” or from interface will cause the drive to generate a fault, F_36. Regardless of the mode of operation, if the input is deactivated while the drive is enabled, the drive will be disabled and will generate a fault, F_36.



WARNING!

Enabling the servo drive allows the motor to operate depending on the reference command. The operator must ensure that the motor and machine are safe to operate prior to enabling the drive and that moving elements are appropriately guarded. Failure to comply could result in damage to equipment and/or injury to personnel!

6.6 Drive Tuning

The PositionServo Drive will likely require some tuning of its gains parameters in order to achieve best performance in the application in which it is being applied. Only when the drive is placed in Torque Mode are the gain values not required to be tuned. The table herein lists the gains parameters that should be adjusted for each of the drive operating modes. These parameters are found within the ‘Compensation’ folder.

MotionView Parameter	Torque Mode	Velocity Mode	Positioning Mode
Velocity P Gain	No	Yes	Yes
Velocity I Gain	No	Yes	Yes
Position P Gain	No	No	Yes
Position I Gain	No	No	Yes
Position D Gain	No	No	Yes
Position I-Limit	No	No	Yes
Gain Scaling	No	Yes	Yes

Before using the tuning procedures detailed in the next sections, ensure that the system is in a safe condition for tuning to be carried out. It is often beneficial to first tune the motor off-load to obtain approximate gains setting before fine tuning in the application.

Check that the drive output to the motor is disabled (via Input A3) and that the drive is powered up. Make sure any user program code previously entered into the [Indexer Program] folder in MotionView has been saved prior to tuning so it can be easily recalled after tuning is complete.



WARNING!

During both the Velocity and Position tuning procedures the PositionServo drive will perform rotation (motion) of the motor shaft in the forward and reverse directions at velocities based on the settings made by the user. Ensure that the motor and associated mechanics of the system are safe to operate in the way specified during these procedures.

6.6.1 Tuning the Drive in Velocity Mode

1) Parameter Setup

Set up the motor as per the instructions given in the relevant section of this manual. The motor must be configured correctly prior to tuning taking place.

The parameters Drive Mode, Reference and Enable Switch Function are configured automatically by the velocity tuning program. They are not required to be set at this stage.

2) Importing the Velocity Tuning Program

Before importing the Velocity Tuning Program, the example programs must be installed from the Documentation CD that shipped with the drive. If this has not been done then please do so now.

To load the TuneV program file to the drive, select [Indexer Program] in the MotionView Parameter Tree. Select [Import program from file] on the main toolbar. Navigate to [C:\Program Files\AC Technology\MotionView6.xx\Help\940Examples]. If during the installation of the Documentation CD files a different default directory was selected, then navigate to that directory. Click on the [TuneV.txt] file and select [Open].



3) Editing the Velocity Tuning Program

The Tune Velocity Program creates a step velocity demand in the forward and reverse directions that the drive will attempt to follow (based on its velocity gain settings). The drive will run for a set time in the forward direction and then reverse the reference and run for the same set time in the reverse direction, showing the acceleration, deceleration and steady state performance.

The speed and period (time for one complete cycle - forward and reverse) is set in the Indexer program with the following statements:

```
; Motion Parameters
Define SpeedReference 5 ; speed reference in Rps
Define Period 500 ; time in millisec
```

Adjust these parameters to values suitable to the application in which the drive is used before going to the next step.

Operation

4) Compile and Download Indexer Program to Drive

In the [Indexer program] folder in MotionView, select [Compile and Load with Source] from the pull down menu. The TuneV program will be compiled and sent to the drive. Select [Run] from the pull down menu to run the TuneV program. Do NOT enable the drive (via input A3) at this stage.

5) Oscilloscope Settings

Open the [Tools] folder in MotionView and select the [Oscilloscope] tool. Click the [Set on Top] box to place a checkmark in it and keep the scope on top.

In the Scope Tool Window make the following settings:

Channel 1: Signal = "Commanded Velocity"

Scale = appropriate to "SpeedReference" value set in Indexer Program

Channel 2: Signal = "Motor Velocity"

Scale = appropriate to "SpeedReference" value set in Indexer Program

Timebase: = as appropriate to "Period" value of Indexer Program

Trigger: = Channel 1, Rising Edge

Level: = 10 RPM

For better resolution, adjust these scaling factors during the tuning procedure.

6) Compensation Folder

In MotionView, open the [Compensation] folder for the drive. Set [Gain Scaling] to a relatively low value, e.g. -6 for Encoder motor and -8 for a Resolver Motor. Set the [Velocity P-gain] to a mid-value (16000) and set the [Velocity I-Gain] to 0.

7) Gain Tuning

The system should now be ready to start tuning the velocity gains. Start the Oscilloscope by clicking [Run]. Apply the Enable input to Input A3 to enable the drive. At this point of the procedure it is desirable to have little to no motion until we start to increase the gain settings. If the motor vibrates uncontrollably disable the drive, lower the Gain Scaling parameter value and repeat the input enable.

Step 1: Setting the Gain Scaling Parameter

The gain scaling parameter is a 'course adjustment' of the other gain's parameter values. Steadily increase the value of the gain scaling parameter until a reasonable response is obtained from the motor (motor velocity starts to resemble the commanded velocity).



Gain Scaling set too LOW
Motor Velocity significantly different than
Commanded Velocity.

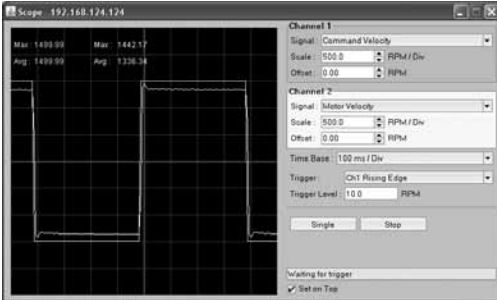

Gain Scaling set OK
Motor Velocity resembles Commanded Velocity. Motor Velocity is reasonably close with a slight overshoot.



Gain Scaling set too HIGH
Motor Velocity shows significant overshoot following the acceleration periods.

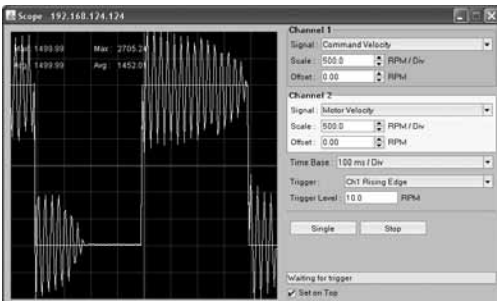

Gain Scaling set significantly too HIGH
Motor Velocity exhibits instability throughout the steady state Commanded Velocity.

Depending on the system begin tuned, the motor may go from stable operation (little to no overshoot with stable steady state velocity) to instability (continuous and pronounced oscillations during steady state command) very quickly as gains scaling is increased. The bandwidth for allowing some overshoot with a quick settle time may be very small and may only be achieved through adjustment of the Velocity P-Gain, as described in Step 2. Set the gain scaling parameter to the value preceding that where significant overshoot or continuous instability occurs. With the Gain scaling parameter set move onto tuning the velocity P and I gains.

Operation

Step 2: Fine Tuning the Velocity P-Gain

Slowly alter the Velocity P-Gain (increase and decrease) and observe the motor velocity waveform on the oscilloscope. As the P-Gain increases the gradient of the velocity during acceleration and deceleration will also increase as will the final steady state velocity that is achieved. The application of too much P-Gain will eventually result in an overshoot in the motor velocity, and further increases will result in larger overshooting to the point that instability (continuous oscillation) occurs.

Increase the velocity P-gain until some overshoot occurs. Some overshoot is generally ok, and the objective is typically to achieve the shortest possible settle time (steady state velocity). When the system appears to have reached the shortest possible settle time, with acceptable overshoot, cease from increasing the P-Gain.

Scope traces will be similar to those shown in Step 1, however the P-gain will now be given a more precise adjustment in order to obtain the best possible tuning.

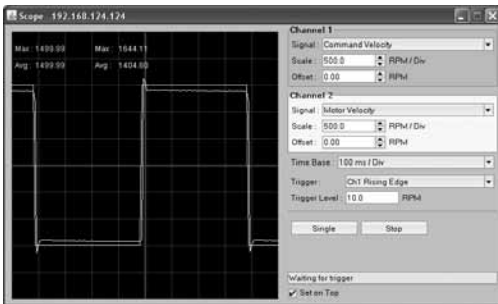

Good Fine Tuning of the P-Gain
Small overshoot with excellent settle time and steady state velocity regulation.

Step 3: Setting the Velocity I-Gain

The purpose of the velocity I-gain is to correct any error that is present between the commanded velocity and the steady state velocity that could not be rectified by adjustment of the velocity P-gain. Adjustment of the velocity I-gain can also reduce the steady state ripple that may occur in the velocity waveform. Lastly, velocity I-gain has a positive effect on the holding torque produced by the motor.

Slowly increase the “Velocity I-Gain” and check for correction of the steady state error in the velocity waveform. Continuing to increase the velocity I-gain will eventually result in increased overshoot and instability in the motor velocity waveform. Stop increasing the I-Gain when additional overshoot or instability starts to occur.

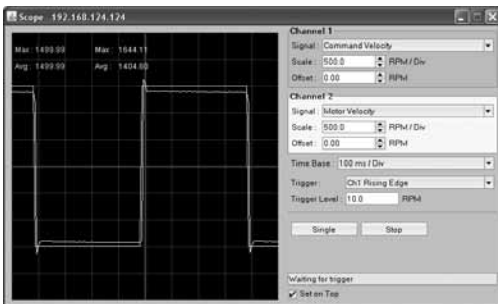

I-Gain set too LOW
Error exists between Commanded steady state velocity and Actual steady state velocity

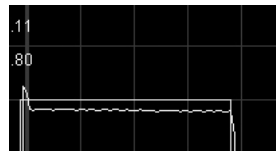

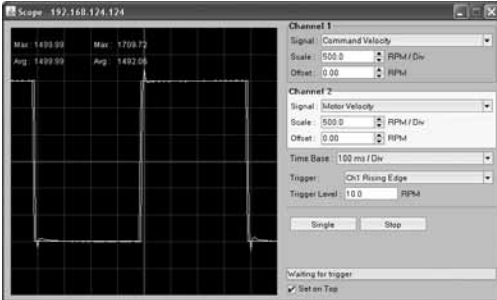

I-Gain set OK
No error between Commanded steady state velocity and Actual steady state velocity with excellent stability.

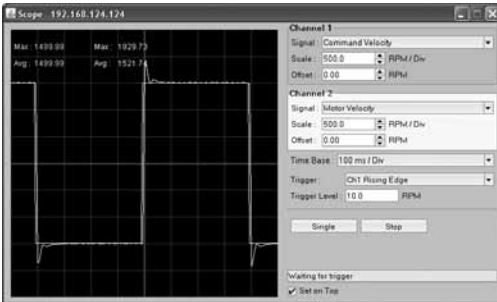
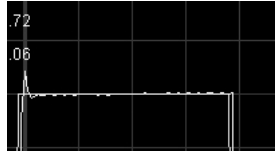

I-Gain set too HIGH
Additional overshoot and oscillations are starting to occur. Steady state velocity regulation

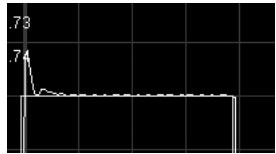

Step 4: Check Motor Currents

Finally check the motor currents on the Oscilloscope. Make the following settings to the oscilloscope.

Channel 1:

Signal = "Phase Current RMS"

Scale = as appropriate to peak current limit set in drive parameters (MotionView)

Timebase: = as appropriate to "Period" value of Indexer Program

Trigger: = Channel 2, Rising Edge

Level: = 10 RPM

Observe the waveforms to insure there are no significant oscillations. Reduce the gains values if necessary.

The current waveform should be showing spikes of current during acceleration / deceleration and steady state current during any steady state velocity. The maximum value (peak value) of the current waveform is shown at the top of the oscilloscope screen. This maximum value can be compared to the drive nominal current and peak current settings to check how much of the motors potential performance is being used and if optimum performance is being achieved.

Operation

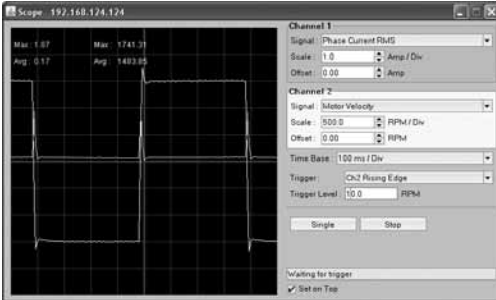

Good Current Trace
Uniform current pulses during accel/
deceleration and stable current during steady
state velocity.

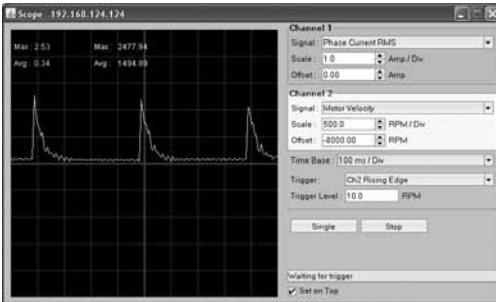
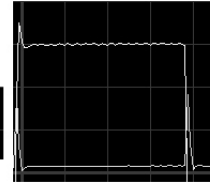

Instability in Drive Output Current
(Note: Channel 2 trace has been removed for
clarity).

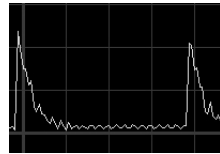

8) End Velocity Tuning

Remove the Enable Input from input A3 (disable the drive). In MotionView, click on the [Indexer] folder for the drive. Click [Reset] on the program toolbar. If the drive is to be run in just velocity mode then tuning is now complete. If the drive is to be used in Positioning mode continue with 'Tuning the Drive in Position Mode', section 6.6.2.

6.6.2 Tuning the Drive in Position Mode

Velocity Tuning should be carried out prior to the tuning of the position loop. Refer to the Velocity Tuning section, 6.6.1.

1) Parameter Set up

In MotionView, open the [Limits] folder and then the [Position Limits] sub-folder. Set the [Position Error] and [Max Error Time] parameters to their maximum values to effectively disable the position error trip while tuning takes place. Ensure the system is safe to operate in this manner.

Position Error = 32767

Max Error Time = 8000

The Drive Mode, Reference and Enable Switch Function parameters are automatically configured by the velocity tuning program. They do not require setting at this stage.



2) Importing the Position Tuning Program

Before importing the Position Tuning Program, the example programs must be installed from the Documentation CD that shipped with the drive. If this has not been done then please do so now.

To load the TuneP program file to the drive, select [Indexer Program] in MotionView. Select [Import program from file] on the main toolbar. Navigate to [C:\Program Files\AC Technology\MotionView6.x\Help\940Examples]. If during the installation of the Documentation CD files a different default directory was selected, then navigate to that directory. Click on the [TuneP.txt] file and select [Open].



3) Editing the Position Tuning Program

The Tune Position Program performs trapezoidal moves in the forward and reverse direction separated by a defined pause (or time delay).

The Accel, Decel, and MaxV variables within the TuneP program define the ramps and steady state velocity that will be used to execute the motion commands.

ACCEL = 500	;500 rps*s	Accel = Acceleration speed
DECEL = 500	;500 rps*s	Decel = Deceleration speed
MAXV = 20	;20 Rps	MaxV = Maximum

The size of each move and the pause between the moves is defined in the following lines of code. There are two moves and pauses for the forward and reverse moves to be performed.

MOVED 0.25	;move 1 rev	MoveD = Move distance
wait time 200	;wait time to analyze 'standstill' stability	wait time = Delay period
MOVED -0.25	;move opposite direction 1 rev	
wait time 200	;wait time to analyze 'standstill' stability	

Adjust these parameters if required to best suit the application before going to the next step.

4) Compile and Download Indexer Program to Drive

In the [Indexer Program] folder in MotionView, select [Compile and Load with Source] from the pull down menu. The TuneP program will be compiled and sent to the drive. Select [Run] from the pull down menu to run the TuneP program. Do NOT enable the drive (via input A3) at this stage.

Operation

5) Oscilloscope Settings

Open the [Tools] folder in MotionView and select the [Oscilloscope] tool. Click the [Set on Top] box to place a checkmark in it and keep the scope on top.

In the Scope Tool Window, make the following settings:

Channel 1:

Signal = "Position Error"

Scale = as appropriate to the Error that results once the TuneP program is run.

Channel 2:

Signal = "Target Position"

Scale = as appropriate to the position move generated by the TuneP program

Timebase: = as appropriate to the "Period" of the moves being generated.

Trigger: = Channel 1, Rising Edge.

Level: = 10 Pulses

6) Compensation Folder

Open the [Compensation] folder in MotionView.

Leave the Velocity P-Gain and Velocity I Gain unchanged, as they should already have been setup during velocity tuning. Do not adjust the Gain Scaling Parameter during this procedure.

Set the [Position P-gain] to a low value (e.g. 100) and set the [Position I-Gain] and [Position D-Gain] to 0.

7) Gain Tuning

The system should now be ready to start tuning the position loop. Start the Oscilloscope by clicking [Run]. Apply the Enable input A3 to enable the drive.

The general goal in tuning the position loop is to achieve the minimum position error while maintaining system stability. Some experimentation with gain values will be required to achieve the best performance for the application.

Step 1: Setting the Position P-Gain

Slowly increase the Position P-Gain while watching the position error waveform on oscilloscope Channel 1. It is important to watch both the Max Error as well as the Average Error. While increasing Position P-gain, it should be apparent that both the Max Error as well as the Average Error decrease.

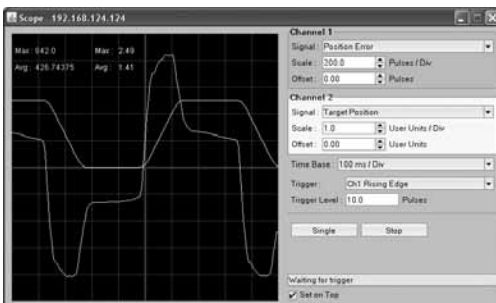

Position P-Gain set too LOW
Large Position Error occurring and large error
in final positioning achieved



Increased Position P-Gain
Shows improvement to the maximum error
and the final positioning accuracy

At some point while increasing the P-Gain, additional oscillations (Average Error) will start to appear on the position error waveform.



Further Increased Position P-Gain
Shows very good reduction to the maximum
error but with additional oscillations starting
to occur.

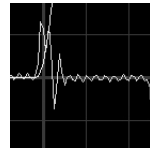

Step 2: Setting the Position D-Gain

Slowly increase the D-Gain while watching the position error waveform on oscilloscope Channel 1. As the D-Gain is increased, the position error oscillation caused by the P-Gain, should start to decrease. Continue to increase the D-Gain until oscillation is gone or until D-Gain is no longer having any apparent effect.



Adjustment of Position D-Gain
in conjunction with the P-Gain dampens
out additional oscillations while improving
position error.

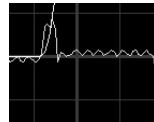

For optimum tuning, it is sometimes required to repeat the process of increasing the P-Gain until a slight oscillation occurs and then increase the D-Gain to suppress that oscillation. This procedure can be repeated until the increasing of D-Gain has negligible effect on the position error waveform.

Operation

Step 3: Setting the Position I-Gain and Position I-Gain Limit

The objective here is to minimize the position error during steady state operation and improve positioning accuracy. Start to increase the Position I-gain. Increasing the I-gain will increase the drive's reaction time while the I-Limit will set the maximum influence that the I-Gain can have on the Integral loop. When adjusting the I-gain start with a very small value for the I-gain (e.g. 1) then increase the I-gain parameter value until stand-still error is compensated and positioning accuracy is satisfactory. Remember that large values of Position I-limit can cause a large instability in the control loop and unsettled oscillation of the system mechanics.

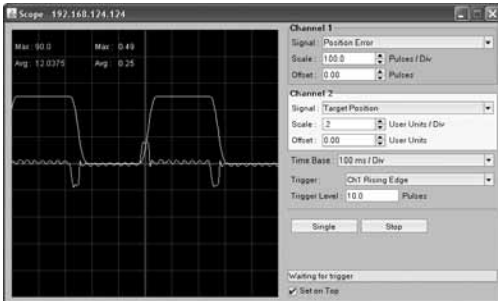

Position Error trace following the tuning of Position P-, I- and D-Gains

Step 4: Check Motor Currents

Set the oscilloscope channel 2 to 'Phase Current RMS'

Channel 2:

Signal = "Phase Current RMS"

Scale = as appropriate to peak current limit set in drive parameters (MotionView)

Timebase: = as appropriate to the "Period" of the moves being generated

Trigger: = Ch1 Rising Edge

Level: = 10 Pulses

Observe the Current waveform to make sure that there are no significant oscillations during the steady state sections of the position profile (times when target position is not changing). If so then decrease the gains values until the oscillations are either removed or reduced to an acceptable level.



Minimal oscillation when motor positioned to target position.

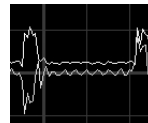



8) Setting the Position Error Limits

Look at the position error waveform on the oscilloscope. Note the maximum time that position errors exist (from the time axis of the scope) and the maximum peak errors being seen (from the value at the top of the screen). Use these values to set the position error limits to provide suitable position error protection for the application.

Open the 'Limits' folder and 'Position Limits' sub-folder within the MotionView node tree and set suitable values for the 'Position Error' and 'Max Error Time' parameters.



Maximum error and time period for error existing.

Max : 95.0
Avg : 11.85



Time Base : 100 ms / Div

In this particular example maximum error in pulses is 95.0. The time this peak error occurs can be read from the oscilloscope at approximately $\frac{1}{2}$ of a division with each division equal to 100ms, hence the error pulse lasts approximately 50ms. Suitable settings for position error within this application might be as follows, although looser or tighter limits could be applied depending on the requirements of the application.

Description	Value
Position Error	100
Max Error Time	50

9) End Tuning

Remove the Enable Input from input A3 (disable the drive).

Click on the [Indexer Program] folder in MotionView. Click the [Reset] button at the top of the indexer programming screen.

Tuning is now complete.



7 Quick Start Reference

This section provides instructions for External Control, Minimum Connections and Parameter Settings to quickly setup a PositionServo drive for External Torque, Velocity or Positioning Modes. The sections are NOT a substitute for reading the entire PositionServo User Manual. Observe all safety notices in this manual.

7.1 Quick Start - External Torque Mode

Mandatory Signals:

These signals are required in order to achieve motion from the motor.

Connector - Pin	Input Name	Description
P3-22	ACOM	Analog Common Reference from Controller
P3-24	AIN1+	Analog Torque Reference from Controller – Positive
P3-25	AIN1-	Analog Torque Reference from Controller – Negative
P3-26	IN_A_COM	Common Input for Enable Input
P3-29	IN_A3	Enable Input to Controller or switch

Optional Signals:

These signals may be required dependant on the control system being implemented.

Connector - Pin	Input Name	Description
P3-6	+5V	+5V Output for Enable Input (If required)
P3-7	A+	Buffered Encoder Output
P3-8	A-	Buffered Encoder Output
P3-9	B+	Buffered Encoder Output
P3-10	B-	Buffered Encoder Output
P3-11	Z+	Buffered Encoder Output
P3-12	Z-	Buffered Encoder Output
P3-23	AO	Analog Output
P3-41	RDY+	Ready output Collector
P3-42	RDY-	Ready output Emitter
P3-43	OUT1-C	Programmable output #1 Collector
P3-44	OUT1-E	Programmable output #1 Emitter
P3-45	OUT2-C	Programmable output #2 Collector
P3-46	OUT2-E	Programmable output #1 Emitter
P3-47	OUT3-C	Programmable output #3 Collector
P3-48	OUT3-E	Programmable output #1 Emitter
P3-49	OUT4-C	Programmable output #4 Collector
P3-50	OUT4-E	Programmable output #1 Emitter

Mandatory Parameter Settings:

These Parameters are required to be set prior to running the drive

Folder / Sub-Folder	Parameter Name	Description
Parameters	Drive Mode	Set to [Torque]
	Reference	Set to [External]
IO / Analog IO	Analog Input (Current Scale)	Set to required current per 1V input from controller
	Analog Input Dead band	Set zero torque Dead band in mV
	Analog Input Offset	Set Analog Offset for Torque Reference
IO / Digital IO	Enable Switch Function	Set to [Run]



Optional Parameter Settings:

These parameters may require setting depending on the control system implemented.

Folder / Sub-Folder	Parameter Name	Description
Parameters	Resolver Track	PPR for simulated encoder on 941 Resolver drive
IO / Digital IO	Output 1 Function	Set to any pre-defined function required
	Output 2 Function	Set to any pre-defined function required
	Output 3 Function	Set to any pre-defined function required
	Output 4 Function	Set to any pre-defined function required
IO / Analog IO	Adjust Analog Input	Tool that can be used to learn analog input level
	Analog Output	Set to any pre-defined function required
	Analog Output Current Scale	Set to scale analog output if current value is selected
	Analog Output Velocity Scale	Set to scale analog output if velocity value is selected
Limits / Velocity Limits	Zero Speed	Set bandwidth for activation of a Zero Speed Output
	At Speed	Set Target Speed for activation of a At Speed Output
	Speed Window	Set bandwidth for activation of a At Speed Output

7.2 Quick Start - External Velocity Mode

Mandatory Signals:

These signals are required in order to achieve motion from the motor.

Connector - Pin	Input Name	Description
P3-22	ACOM	Analog Common Reference from Controller
P3-24	AIN1+	Analog Velocity Reference from Controller – Positive
P3-25	AIN1-	Analog Velocity Reference from Controller – Negative
P3-26	IN_A_COM	Common Input for Enable Input
P3-29	IN_A3	Enable Input to Controller or switch

Optional Signals:

These signals may be required dependant on the control system being implemented.

Connector - Pin	Input Name	Description
P3-6	+5V	+5V Output for Enable Input (If required)
P3-7	A+	Buffered Encoder Output
P3-8	A-	Buffered Encoder Output
P3-9	B+	Buffered Encoder Output
P3-10	B-	Buffered Encoder Output
P3-11	Z+	Buffered Encoder Output
P3-12	Z-	Buffered Encoder Output
P3-23	A0	Analog Output
P3-41	RDY+	Ready output Collector
P3-42	RDY-	Ready output Emitter
P3-43	OUT1-C	Programmable output #1 Collector
P3-44	OUT1-E	Programmable output #1 Emitter
P3-45	OUT2-C	Programmable output #2 Collector
P3-46	OUT2-E	Programmable output #1 Emitter
P3-47	OUT3-C	Programmable output #3 Collector
P3-48	OUT3-E	Programmable output #1 Emitter
P3-49	OUT4-C	Programmable output #4 Collector
P3-50	OUT4-E	Programmable output #1 Emitter



Reference

Mandatory Parameter Settings:

These parameters are required to be set prior to running the drive.

Folder/Sub-Folder	Parameter Name	Description
Parameters	Drive Mode	Set to [Velocity]
	Reference	Set to [External]
	Enable Velocity Accel / Decel Limits	Enable Ramp rates for Velocity Mode
	Velocity Accel Limit	Set required Acceleration Limit for Velocity command
	Velocity Decel Limit	Set required Deceleration Limit for Velocity command
IO / Analog IO	Analog Input (Velocity Scale)	Set to required velocity per 1 volt input from controller
	Analog Input Dead band	Set zero velocity Dead band in mV
	Analog Input Offset	Set Analog Offset for velocity Reference
IO / Digital IO	Enable Switch Function	Set to [Run]
Compensation (see tuning section)	Velocity P-Gain	Set P-Gain for Velocity loop
	Velocity I_Gain	Set I-Gain for Velocity loop
	Gain Scaling	Set Gain Scaling Parameter

Optional Parameter Settings:

These parameters may require setting depending on the control system implemented.

Folder / Sub-Folder	Parameter Name	Description
Parameters	Resolver Track	PPR for simulated encoder on 941 Resolver drive
IO / Digital IO	Output 1 Function	Set to any pre-defined function required
	Output 2 Function	Set to any pre-defined function required
	Output 3 Function	Set to any pre-defined function required
	Output 4 Function	Set to any pre-defined function required
IO / Analog IO	Adjust Analog Input	Tool that can be used to learn analog input level
	Analog Output	Set to any pre-defined function required
	Analog Output Current Scale	Set to scale analog output if current value is selected
	Analog Output Velocity Scale	Set to scale analog output if velocity value is selected
Limits / Velocity Limits	Zero Speed	Set bandwidth for activation of Zero Speed Output
	At Speed	Set Target Speed for activation of At Speed Output
	Speed Window	Set bandwidth for activation of At Speed Output



7.3 Quick Start - External Positioning Mode

Mandatory Signals:

These signals are required in order to achieve motion from the motor.

Connector-Pin	Input Name	Description
P3-1	MA+	Position Reference Input for Master Encoder / Step-Direction Input
P3-2	MA-	Position Reference Input for Master Encoder / Step-Direction Input
P3-3	MB+	Position Reference Input for Master Encoder / Step-Direction Input
P3-4	MB-	Position Reference Input for Master Encoder / Step-Direction Input
P3-26	IN_A_COM	Common Input for Enable Input
P3-29	IN_A3	Enable Input to Controller or switch

Optional Signals:

These signals may be required dependant on the control system being implemented.

Connector - Pin	Input Name	Description
P3-6	+5V	+5V Output for Enable Input (If required)
P3-7	A+	Buffered Encoder Output
P3-8	A-	Buffered Encoder Output
P3-9	B+	Buffered Encoder Output
P3-10	B-	Buffered Encoder Output
P3-11	Z+	Buffered Encoder Output
P3-12	Z-	Buffered Encoder Output
P3-22	ACOM	Analog Common Reference from Controller
P3-23	AO	Analog Output
P3-27	IN_A1	Positive Limit Switch: Required if Limit Switch Function is used
P3-28	IN_A2	Negative Limit Switch: Required if Limit Switch Function is used
P3-41	RDY+	Ready output Collector
P3-42	RDY-	Ready output Emitter
P3-43	OUT1-C	Programmable output #1 Collector
P3-44	OUT1-E	Programmable output #1 Emitter
P3-45	OUT2-C	Programmable output #2 Collector
P3-46	OUT2-E	Programmable output #1 Emitter
P3-47	OUT3-C	Programmable output #3 Collector
P3-48	OUT3-E	Programmable output #1 Emitter
P3-49	OUT4-C	Programmable output #4 Collector
P3-50	OUT4-E	Programmable output #1 Emitter



Reference

Mandatory Parameter Settings:

These parameters are required to be set prior to running the drive.

Folder / Sub-Folder	Parameter Name	Description
Parameters	Drive Mode	Set to [Position]
	Reference	Set to [External]
	Step Input Type	Set to [S/D] or [Master Encoder]. (S/D = Step + Direction)
	System to Master Ratio	Set 'Master' and 'Slave' values to gear position input pulses to pulse revolution of the motor shaft
IO / Digital IO	Enable Switch Function	Set to [Run]
Limits / Position Limits	Position Error	Set Position Error Limit specific to application
	Max Error Time	Set Position Error Time specific to application
Compensation (see tuning section)	Velocity P-Gain	Set P-Gain for Velocity loop
	Velocity I_Gain	Set I-Gain for Velocity loop
	Position P-Gain	Set P-Gain for Position Loop
	Position I-Gain	Set I-Gain for Position Loop
	Position D-Gain	Set D-Gain for Position Loop
	Position I-Limit	Set I-Limit for Position Loop
	Gain Scaling	Set Gain Scaling Parameter

Optional Parameter Settings:

These parameters may require setting depending on the control system implemented.

Folder / Sub-Folder	Parameter Name	Description
Parameters	Resolver Track	PPR for simulated encoder on 941 Resolver drive
IO / Digital IO	Output 1 Function	Set to any pre-defined function required
	Output 2 Function	Set to any pre-defined function required
	Output 3 Function	Set to any pre-defined function required
	Output 4 Function	Set to any pre-defined function required
	Hard Limit Switch Actions	Set if Hard Limit Switches used in Application
IO / Analog IO	Adjust Analog Input	Tool that can be used to learn analog input level
	Analog Output	Set to any pre-defined function required
	Analog Output Current Scale	Set to scale analog output if current value is selected
	Analog Output Velocity Scale	Set to scale analog output if velocity value is selected
Limits / Velocity Limits	Zero Speed	Set bandwidth for activation of a Zero Speed Output
	At Speed	Set Target Speed for activation of a At Speed Output
	Speed Window	Set bandwidth for activation of a At Speed Output



8 Diagnostics

8.1 Display

The PositionServo drives are equipped with a diagnostic LED display and 3 push buttons to select displayed information and to edit a limited set of parameter values.

Parameters can be scrolled by using the “UP” and “DOWN” (▲▼) buttons. To view a value, press “Enter” (↵). To return back to scroll mode press “Enter” again. After pressing the “Enter” button on editable parameters, the yellow LED “C” (see figure in the next section) will blink indicating that parameter value can be changed. Use “UP” and “DOWN” buttons to change the value. Press “Enter” to store new setting and return back to scroll mode.

Display	Description
StAlE	current drive status - ↵ to view: rUn - drive running d.S - drive disabled F.XX - drive fault. Where XX is the fault code (section 8.3.2)
Hx.xx	Hardware revision (e.g. H2.00)
Fx.xx	Firmware revision (e.g. F2.06)
bRud	RS232/RS485(normal mode) baud rate - ↵ to set ▲▼ selects from 2400 to 115200 baudrates
Rdr	Drive's address - ↵ to set ▲▼ sets 0 - 31 drive's address
FLE5	Stored fault's history - ↵ to view ▲▼ scroll through stored faults F0XX - F7XX, "XX" is the fault code (section 8.3.2)
Ht	Heatsink temperature - ↵ to view Shows heatsink temperature in °C if greater than 40°C. Otherwise shows "LO" (low).
EnC	Encoder activity - ↵ to view Shows primary encoder counts for encoder diagnostics activity
HRLL	Displays motor's hall sensor states - ↵ to view Shows motor hall states in form XXX, where X is 1 or 0 - sensor logic states.
boot	0 = Autoboot disabled 1 = Autoboot enabled (Feature available in FW 3.50 or higher)
bU5	Displays drive DC bus voltage - ↵ to view Shows DC bus voltage value
CUrr	Displays motor's phase current (RMS) Shows current value if drive is enabled, otherwise shows "d.S"
CRnb	CAN Baudrate
CRnA	CAN Address
CRno	CAN Operational Mode
CRnd	CAN Delay
CRnE	CAN Enable/disable
dHCP	Ehternet DHCP Configuration: 0="dHCP" is disabled; 1="dHCP" is enabled.
IP_4	IP Adress Octet 4
IP_3	IP Adress Octet 3
IP_2	IP Adress Octet 2
IP_1	IP Adress Octet 1



Diagnostics

8.2 LEDs

The PositionServo has five diagnostic LEDs located around the periphery of the front panel display as shown in the drawing below. These LEDs are designed to help monitor system status and activity as well as troubleshoot any faults.

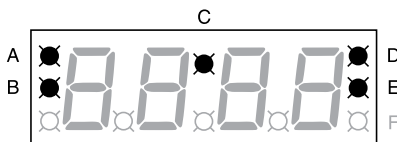

S913

LED	Function	Description
A	Enable	Orange LED indicates that the drive is ENABLED (running).
B	Regen	Yellow LED indicates the drive is in regeneration mode.
C	Data Entry	Yellow LED will flash when changing.
D	Comm Fault	Red LED illuminates upon a communication fault. (in CANbus only)
E	Comm Activity	Green LED flashes to indicate communication activity.

8.3 Faults

8.3.1 Fault Codes

Listen herein are fault codes caused mostly by hardware operations. Refer to the PositionServo Programming Manual for additional fault codes related to programming.

Fault Code (Display)	Fault	Description
F_0U	Over voltage	Drive bus voltage reached the maximum level, typically due to motor regeneration
F_Fb	Feedback error	Invalid Hall sensors code; Resolver signal lost or at least one motor hall sensor is inoperable or not connected.
F_0C	Over current	Drive exceeded peak current limit. Software incapable of regulating current within 15% for more than 20mS. Usually results in wrong motor data or poor tuning.
F_0t	Over temperature	Drive heatsink temperature has reached maximum rating. Trip Point = 100°C for all drives except 480V 6A & 9A drives Trip Point = 108°C for 480V 6A & 9A drives
F_0S	Over speed	Motor has reached velocity above its specified limit
F_PE	Position Error Excess	Position error has exceeded maximum value.
F_bd	Bad motor data	Motor profile data is invalid or no motor is selected.
F_EP	EPM failure	EPM failure on power up
-EP-	EPM missing	EPM not recognized (connected) on power up
F_09	Motor over temperature	Motor over temperature switch activated; Optional motor temperature sensor (PTC) indicates that the motor windings have reached maximum temperature
F_10	Subprocessor failure	Error in data exchange between processors. Usually occurs when EMI level is high due to poor shielding and grounding.
F_14	Under voltage	Occurs when the bus voltage level drops below 50% of nominal bus voltage while drive is operating. An attempt to enable the drive with low bus voltage will also result in this fault



Fault Code (Display)	Fault	Description
F_15	Hardware overload protection	Occurs when the phase current becomes higher than 400% of total drive's current capability for more than 5µs.
F_18	Arithmetic Error Division by zero	Statement executed within the Indexer Program results in a division by 0 being performed. Drive programming error (error in drive source code).
F_19	Arithmetic Error Register overflow	Statement executed within the Indexer Program results in a value being generated that is too big to be stored in the requested register. Drive programming error (error in drive source code).
F_20	Subroutine stack overflow	Exceeded 32 levels subroutines stack depth. Caused by executing excessive subroutine calls without a RETURN statement. Drive programming error (error in drive source code).
F_21	Subroutine stack underflow	Executing RETURN statement without preceding call to subroutine. Drive programming error (error in drive source code).
F_22	Arithmetic stack overflow	Variable evaluation stack overflow. Expression too complicated for compiler to process. Drive programming error (error in drive source code).
F_23	Motion Queue overflow	32 levels depth exceeded. Drive programming error (error in drive source code).
F_24	Motion Queue underflow	Relates to the MDV statements in the Indexer Program. Drive programming error (error in drive source code).
F_25	Unknown opcode	Byte code interpreter error; May occur when program is missing the closing END statement; when subroutine has no RETURN statement; or if data in EPM is corrupted at run-time
F_26	Unknown byte code	Byte code interpreter error; May occur when program is missing the closing END statement; when subroutine has no RETURN statement; or if data in EPM is corrupted at run-time
F_27	Drive disabled	Attempt to execute motion while drive is disabled. Drive programming error (error in drive source code).
F_28	Accel too high	Motion statement parameters calculate an Accel value above the system capability. Drive programming error (error in drive source code).
F_29	Accel too low	Motion statement parameters calculate an Accel value below the system capability. Drive programming error (error in drive source code).
F_30	Velocity too high	Motion statement parameters calculate a velocity above the system capability. Drive programming error (error in drive source code).
F_31	Velocity too low	Motion statement parameters calculate a velocity below the system capability. Drive programming error (error in drive source code).
F_32	Positive Limit Switch	Positive limit switch is activated. (Only available while drive is in position mode)
F_33	Negative Limit Switch	Negative limit switch is activated. (Only available while drive is in position mode)
F_34	Positive motion w/ Pos Lim Sw ON	Attempt at positive motion with engaged positive limit switch
F_35	Negative motion w/ Neg Lim Sw ON	Attempt at negative motion with engaged negative limit switch
F_36	Drive Disabled by User at Enable Input	The drive is disabled while operating or an attempt is made to enable the drive without deactivating "Inhibit input". "Inhibit" input has reverse polarity
F_39	Positive soft limit reached	Programmed (Soft) absolute limits reached during motion
F_40	Negative soft limit reached	Programmed (Soft) absolute limits reached during motion
F_41	Unknown Variable ID	Attempt to use variable with unknown ID from user program. Drive programming error (error in drive source code).
F_45	2nd Encoder Position Error	Secondary encoder position error has exceeded maximum value



8.3.2 Fault Event

When drive encounters any fault, the following events occur:

- Drive is disabled
- Internal status is set to "Fault"
- Fault number is logged in the drive's internal memory for later interrogation
- Digital output(s), if configured for "Run Time Fault", are asserted
- Digital output(s), if configured for READY, are de asserted
- If the display is in the default status mode, the LEDs display F0XX where XX is current fault code.
- "Enable" LED turns OFF

8.3.3 Fault Reset

Fault reset is accomplished by disabling or re-enabling the drive depending on the setting of the "Reset option" parameter (section 5.3.10).

8.4 Troubleshooting



DANGER!

Hazard of electrical shock! Circuit potentials are up to 480 VAC above earth ground. Avoid direct contact with the printed circuit board or with circuit elements to prevent the risk of serious injury or fatality. Disconnect incoming power and wait at least 60 seconds before servicing drive. Capacitors retain charge after power is removed.

Before troubleshooting

Perform the following steps before starting any procedure in this section:

- Disconnect AC or DC voltage input from the PositionServo. Wait at least 60 seconds for the power to discharge.
- Check the PositionServo closely for damaged components.
- Check that no foreign material has fallen or become lodged in the PositionServo.
- Verify that every connection is correct and in good condition.
- Verify that there are no short circuits or grounded connections.
- Check that the drive's rated phase current and RMS voltage are consistent with the motor ratings.

For additional assistance, contact your local PositionServo® authorized distributor.

Problem	External line fuse blows
Possible Cause	Line fuses are the wrong size Motor leads or incoming power leads are shorted to ground. <i>Nuisance tripping caused by EMI noise spikes caused by poor grounding and/or shielding.</i>
Suggested Solution	<ul style="list-style-type: none"> • Check that line fuses are properly sized for the motor being used. • Check motor cable and incoming power for shorts. • Check that you follow recommendation for shielding and grounding listed in section "shielding and grounding" early in this manual.



Problem	Ready LED is on but motor does not run.
Suggested Solution	<p>If in Torque or Velocity mode: Reference voltage input signal is not applied. Reference signal is not connected to the PositionServo input properly; connections are open. In MotionView program check <Parameters> <Reference> set to <External></p> <p>For Velocity mode only: In MotionView check <Parameters> <Compensation><Velocity loop filter> P-gain must be set to value more then 0 in order to run. Without load motor will run with P-gain set as low as 20 but under load might not. If P-gain is set to 0 motor will not run at all.</p> <p>In Position mode with master encoder motion source (no program) Reference voltage input signal source is not properly selected. In MotionView program check <Parameters> <Reference> set to <External></p> <p>In Position mode using indexing program Variables ACCEL, DECEL,MAXV, UNITS are not set or set to 0. Before attempting the move set values of motion parameters ACCEL, DECEL,MAXV, UNITS</p>
Problem	In velocity mode, the motor runs away.
Possible Cause	<ul style="list-style-type: none"> • Hall sensors or encoder mis-wired. • PositionServo not programmed for motor connected.
Suggested Solution	<ul style="list-style-type: none"> • Check Hall sensor and encoder connections. • Check that the proper motor is selected.

Notes

Notes

Lenze AC Tech Corporation
630 Douglas Street • Uxbridge, MA 01569 • USA
Sales: (800) 217-9100 • Service (508) 278 9100
www.lenze-actech.com

Document
S94P01G-e1