



# FALDIC- $\alpha$ Fuji AC Servo System

RYS-L Type

---

## User's Manual



## CONTENTS

<b>SAFETY INSTRUCTION</b>		9.4 SX bus (SX bus direct connection)	9-8
<b>1. GENERAL</b>	<b>1-1</b>	9.5 T-link (T-link direct connection)	9-11
1.1 Outline	1-1	9.6 General-purpose communication (RS485 interface)	9-14
1.2 System configuration	1-3		
1.3 Functions	1-5	<b>10. INSPECTION AND MAINTENANCE</b>	<b>10-1</b>
1.4 Explanation of model type	1-6	10.1 Inspection	10-1
		10.2 Memory backup	10-1
<b>2. SPECIFICATIONS</b>	<b>2-1</b>	10.3 Fault display	10-2
2.1 Motor	2-1	10.4 Items to inquire when faulty	10-14
2.2 Amplifier	2-11	10.5 Others informations	10-15
2.3 Torque-speed data	2-16		
		<b>11. PERIPHERAL DEVICES</b>	<b>11-1</b>
<b>3. INSTALLATION</b>	<b>3-1</b>	11.1 Cables	11-3
3.1 Motor	3-1	11.2 Auto circuit breaker (FAB, MCCB), earth leakage circuit breaker (ELCB) and magnetic contactor (MC)	11-4
3.2 Amplifier	3-4	11.3 Surge suppressor (surge killer)	11-4
3.3 External dimensions	3-9	11.4 Power filter	11-5
		11.5 AC reactor (reactor for impedance matching)	11-6
<b>4. TERMINAL DIAGRAMS AND WIRING</b>	<b>4-1</b>	11.6 External braking resistor	11-6
4.1 Amplifier, motor and optional devices layout	4-1	11.7 DC reactor	11-7
4.2 Commercial power supply	4-6	11.8 Optional cables, connector kits, battery and external braking resistors	11-8
4.3 Wiring between motor and pulse encoder	4-7		
4.4 Host interface (I/F)	4-10	<b>12. APPENDIXES</b>	<b>12-1</b>
4.5 External connection diagrams (normal, example)	4-26	12.1 Model type selection	12-1
		12.2 Example of program	12-10
<b>5. CONTROL FUNCTIONS</b>	<b>5-1</b>	12.3 Control block diagram	12-18
5.1 Summary	5-1	12.4 Letter symbols and abbreviated words	12-20
5.2 Run command	5-3		
5.3 Manual operation	5-8		
5.4 Origin return	5-13		
5.5 Auto start	5-19		
5.6 Signal for safety	5-39		
5.7 Incidental functions	5-46		
5.8 IQ area	5-59		
5.9 WB area	5-68		
5.10 General-purpose communication	5-74		
<b>6. PARAMETER SETTING</b>	<b>6-1</b>		
6.1 List of parameter	6-2		
6.2 Basic parameter	6-17		
6.3 System parameter	6-35		
<b>7. KEYPAD PANEL</b>	<b>7-1</b>		
7.1 Display	7-1		
7.2 Function list	7-3		
7.3 Sequence mode	7-5		
7.4 Monitor mode	7-10		
7.5 Parameter edit mode	7-15		
7.6 Positioning data edit mode	7-18		
7.7 Test running mode	7-20		
<b>8. SETTING OF POSITIONING DATA</b>	<b>8-1</b>		
8.1 Setting contents	8-1		
8.2 Starting	8-5		
8.3 Setting change	8-6		
8.4 Response time	8-6		
<b>9. TEST (TRIAL) RUNNING OPERATION</b>	<b>9-1</b>		
9.1 Preparation	9-1		
9.2 Motor	9-3		
9.3 Basic type (DI/DO position)	9-4		



## SAFETY INSTRUCTIONS

In all stages of the basic planning of this equipment, its transport, installation, operation, maintenance and check, reference must be made to this manual and other related documents. The correct understanding of the equipment, information about safety and other related instructions are essential for this system.

Cautionary indications DANGER and CAUTION are used in this manual to point out particular hazards and to highlight some unusual information which must be specially noted.

Cautionary indications	Description
 <b>DANGER</b>	Indicates that death or severe personal injury will result if proper precautions are not taken.
 <b>CAUTION</b>	Indicates that personal injury or property damage alone will result if proper precautions are not taken.

Pictorial symbols are used as necessary.

Pictorial symbol	Description	Pictorial symbol	Description
	Do not disassemble		Electrical shock hazard warning

### Warning display

The warning display in Fig. B is located at the arrows in Fig. A.

Fig. A

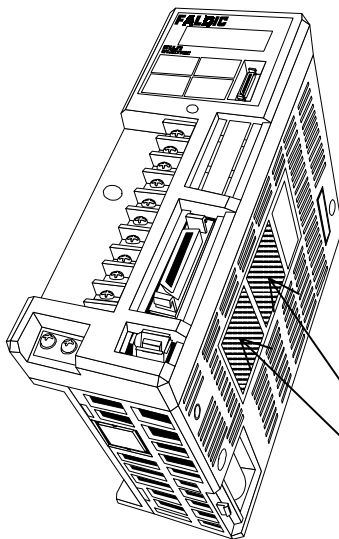



Fig. B



Warning display

Fig. B shows following contents :  
There is a risk of electric shock.

Do not touch the amplifier when a commercial power is applied and for at least five minutes after de-energization.

Be sure to ground (applicable for Japan only : grounding equal to 3rd class grounding structure of Japanese standard (grounding resistance 100 [ ] or less)) must be connected with the terminal marked “”.

 **DANGER**

**Prior to inspection, turn off power and wait for at least five minutes. Otherwise, there is a risk of electric shock.**

**Do not touch the amplifier when the commercial power is supplied. Otherwise, there is a risk of electric shock.**

 **CAUTION**

**Do not disassemble the motor. Otherwise, the operation may be abnormal, thereby damaging the coupled machine.**

**Do not hit the motor with hammer or any other instruments. The integrated (built-in) encoder may break causing the motor to run at an excessive speed.**

**Do not connect a commercial power supply directly to the motor. Otherwise, it may break.**

**Supplying other than 200 [V] or 100 [V] (according to input voltage class of amplifier) to the amplifier may break it.**

**Do not turn on and off the commercial power repeatedly. Otherwise, the amplifier rectifier may break.**

**The motor must be firmly tightened to the mounting base or the driven machine. If rapid acceleration or deceleration is attempted without this firm tightening, the motor may become dislocated.**

**Withstand voltage and insulation test with megger must not be conducted.**

Products introduced in this manual have not been designed or manufactured for such applications in a system or equipment that will affect human bodies or lives. Customers, who want to use the products introduced in this manual for special systems or devices such as for atomic-energy control, aerospace use, medical use, and traffic control, are requested to consult the Fuji. Customers are requested to prepare safety measures when they apply the products introduced in this manual to such systems or facilities that will affect human lives or cause severe damage to property if the products become faulty.

The technical data and dimensions are subject to change without notice in the individual pages of this document.

The illustrations are for reference-only.

The company names and product names described herein are generally the registered trade names.

Although this manual indicates technical units given in SI units, the indications (rating plate, etc.) on the products themselves may be in units other than SI units.

## 1. GENERAL

### 1.1 Outline

The FALDIC- series which corresponds to a host interface is an AC servo system for motion-control necessary for a driven machine.

#### (1) Model type in this manual

- (a) Amplifier (\*) : RYS        S3-LPS , LSS , LTS    and LRS
- (b) Motor (\*) : GYC        DC1-S\* - \* \* \* \*
- GYS        DC1-S\* - \* \* \* \*
- (c) Gear head : GYN        SAG-G
- GRN        SAG-G

#### (2) Main features of product

- (a) Save-wiring 16 bit serial pulse encoder (encoder) (65536 pulses/rev.)
- (i) On the motor, an encoder for any of INC and ABS systems is mounted.
- (ii) If a battery is mounted on the amplifier, it is usable as ABS system.
- (iii) Encoder cabling consists of 2 wires for power supply and 2 for signal, of totally 4 wires. For ABS system, 2 wires for battery must be added.
- (iv) A motor of a different output [kW] can be driven without changing the encoder setting provided that it has a rated output of frame No. (size) equal to the output to apply, one step smaller or greater. Refer to 10.3 (3) (d) .
- (v) The basic resolution is 65536 pulses/rev., and the frequency dividing output is 16 to 16384 pulses/rev.

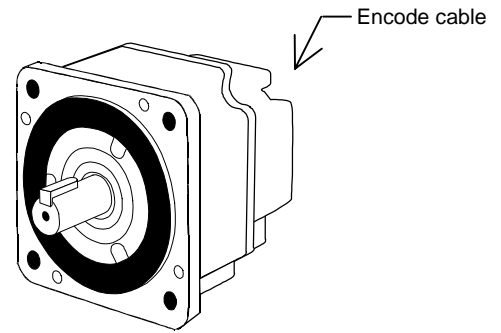

#### (b) Preparing a PC (\*) loader



- (i) Servo system support tools capable of controlling the para. (\*) editing, monitoring, test (trial) running, etc. are available.
- (ii) Fault diagnostic function alarm can be detected and fault cause covering the mechanical equipment system can be assumed.

- (\*) Amplifier : Servo-amplifier
- Motor : Servo-motor
- PC : Personal computer
- Para. : Parameter(s)

(c) Closely mountable amplifiers

- (i) Several amplifiers can be mounted sidewise spaced by less than 5 [mm] between themselves. In that case, however, the operation duty is not continuous but 80%ED. Refer to 3.2 (2) .
- (ii) Control power supply input terminals are provided. Maintenance is available at a status where the main circuit power supply is turn off.
- (iii) PN terminals for harmonics suppression are provided. A DC reactor can be mounted.
- (iv) A keypad (touch) panel is provided.
- (v) You can select a control function from 3 types:
  - 1) Pulse train input /speed control type (RYS-V type amplifier : Input frequency 500 [kHz] max.)
  - 2) Linear positioning function (RYS-L type amplifier : Maximum command value  $\pm 79,999,999$ )  
A linear positioning system combined with ball-screw or other mechanisms.
  - 3) Rotation indexing system (RYS-R type amplifier : Maximum indexing number 30000)  
A rotation indexing system combined with ATC, tool magazine, etc. or other mechanisms.

(d) Cubic/slim type motors

- Cubic type of approximately half the depth of our basic type motor and slim type of flange of approximately half size are obtained.
- (i) The degree of protection (motor enclosure protection) is IP55.  
Optionally, IP67 can be supplied.
  - (ii) 0.03 to 5 [kW] are available.
  - (iii) Acceptable acceleration vibration is  $49 [m/s^2]$  and the slit plate material of 16 bit serial encoder is non-glass film.

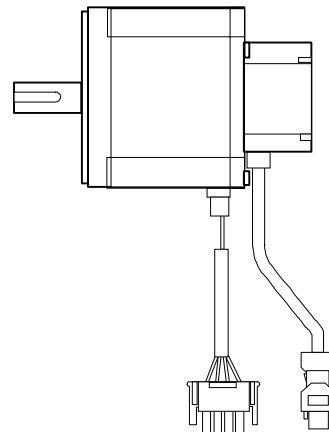
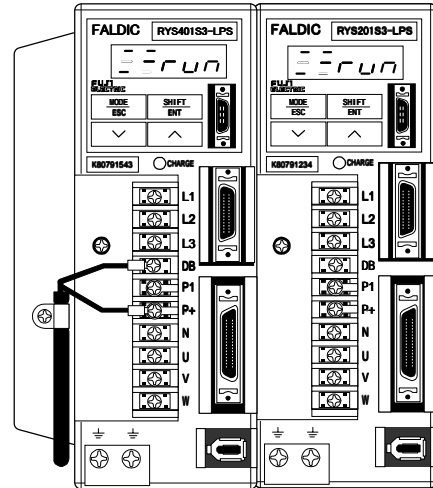

## 1.2 System configuration

The following illustrates related devices of FALDIC- $\alpha$  system.

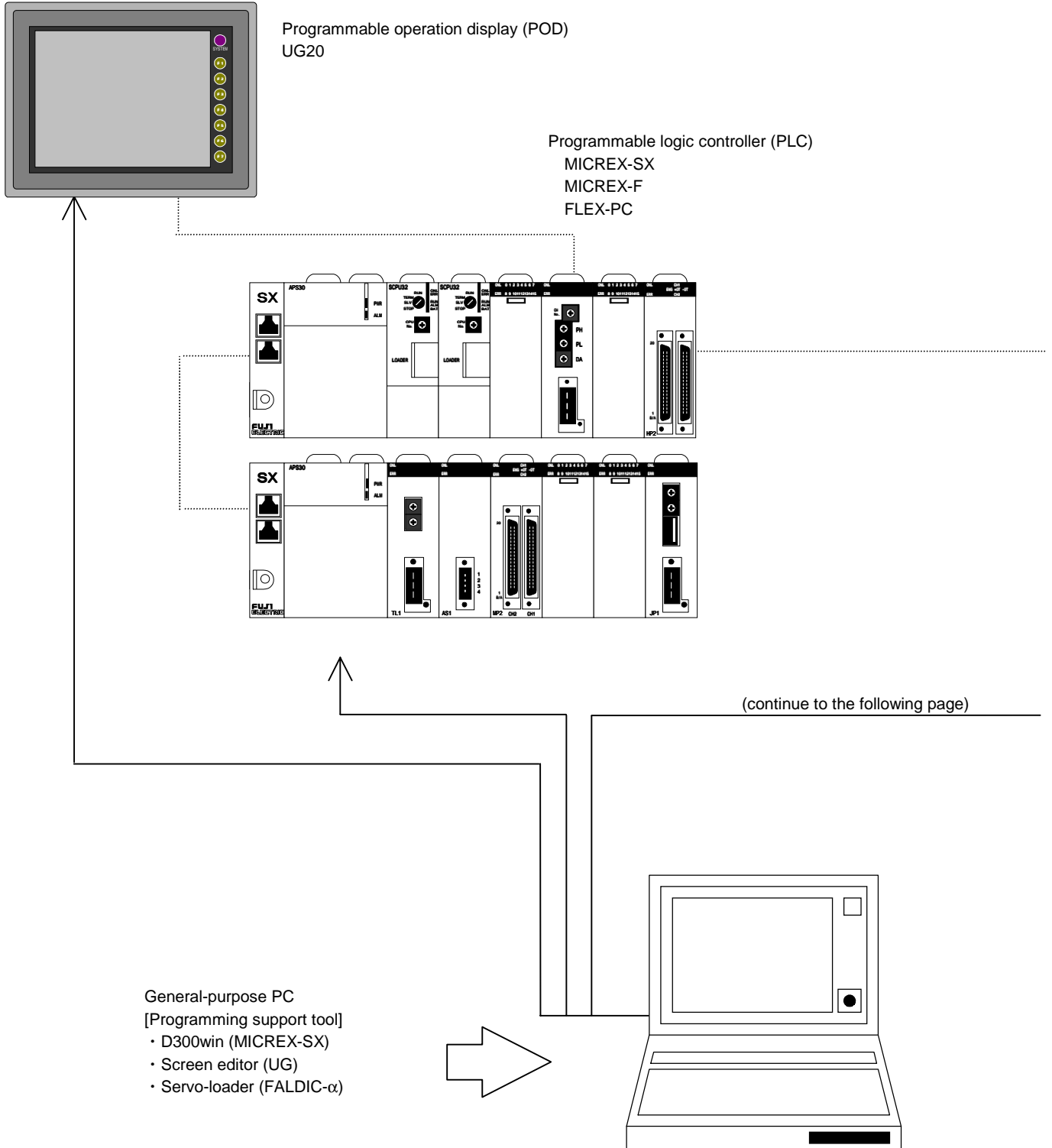

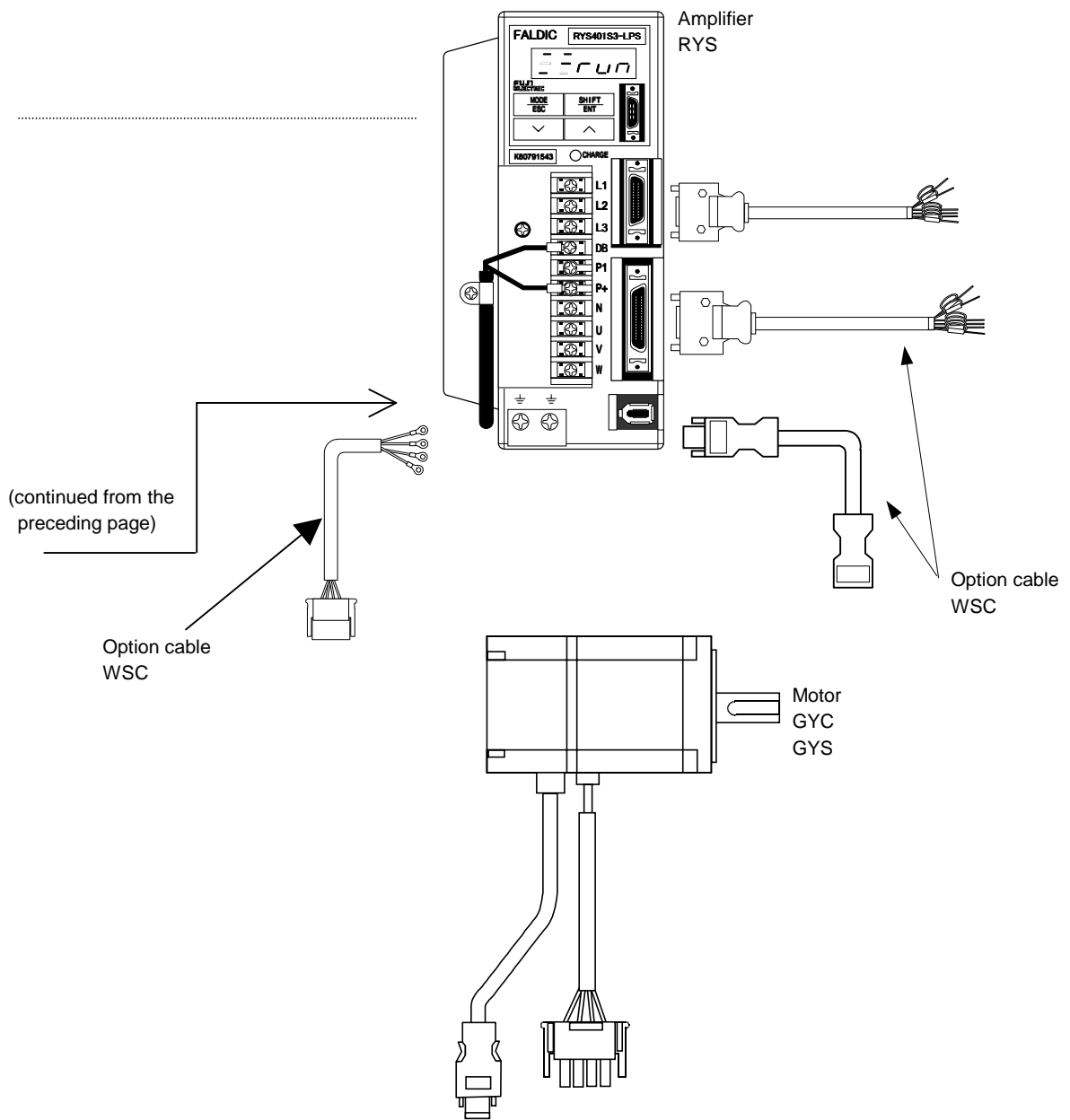

### 1.3 Functions

The FALDIC- $\alpha$  series has 3 types of control function for particular applications.

#### (1) RYS-V type : Pulse train/speed control (velocity)

Maximum input frequency 500 [kHz]

Rotates according to pulse train from host control equipment, or speed command from encoder or variable resistor.

The host interface has :

- DI/DO speed (minimum DI/DO),
- SX bus type,
- Open network, etc.

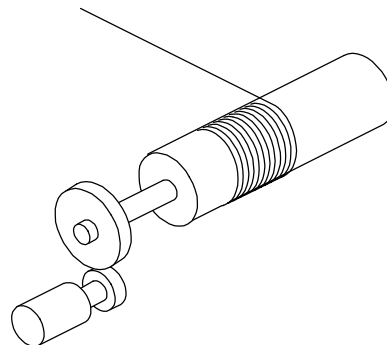

#### (2) RYS-L type : Linear positioning system (linear motion)

Maximum command value  $\pm 79,999,999$

The amplifier can compose a linear positioning system, combined with ball-screw, timing belt, rack and pinion or other mechanisms.

As positioning data, 99 sets (points) of position, current (present) position output, immediate positioning, M-code output etc. can be registered.

The host interface has :

- DI/DO position (expanded DI/DO),
- SX bus type,
- T-link type,
- Open network, etc.

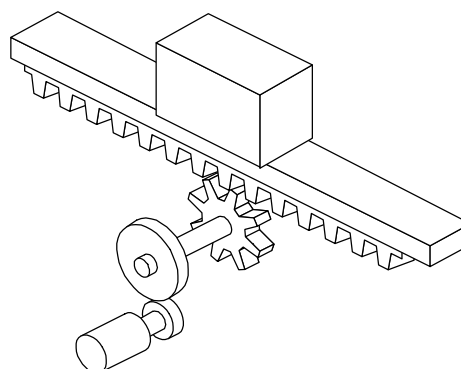

#### (3) RYS-R type : Rotation indexing system (rotation)

Maximum indexing number 30000

The amplifier can compose a rotation indexing system, combined with ATC, tool magazine, loader/unloader, etc. or other mechanisms.

The rotation indexing system is usable for shorted route control, 2nd origin, one-point halt, single-direction infinite rotation, etc.

The host interface has :

- DI/DO position (expanded DI/DO),
- SX bus type,
- T-link type,
- General-purpose communication (RS485 interface),
- Open network, etc.

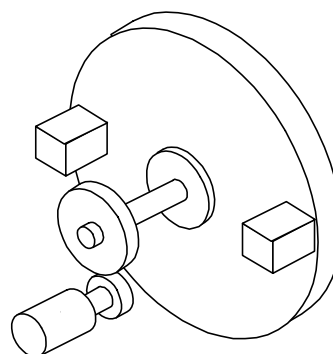

### 1.4 Explanation of model type

Model type of amplifier and motor is expressed with a combination of figures and letters :

#### (a) Amplifier

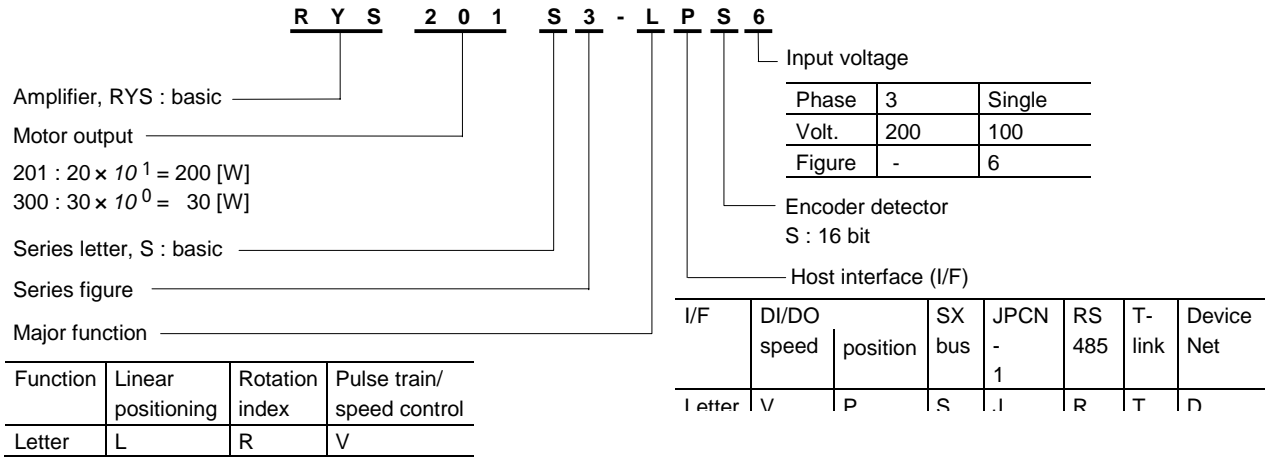

#### (b) GYS/GYC type motor

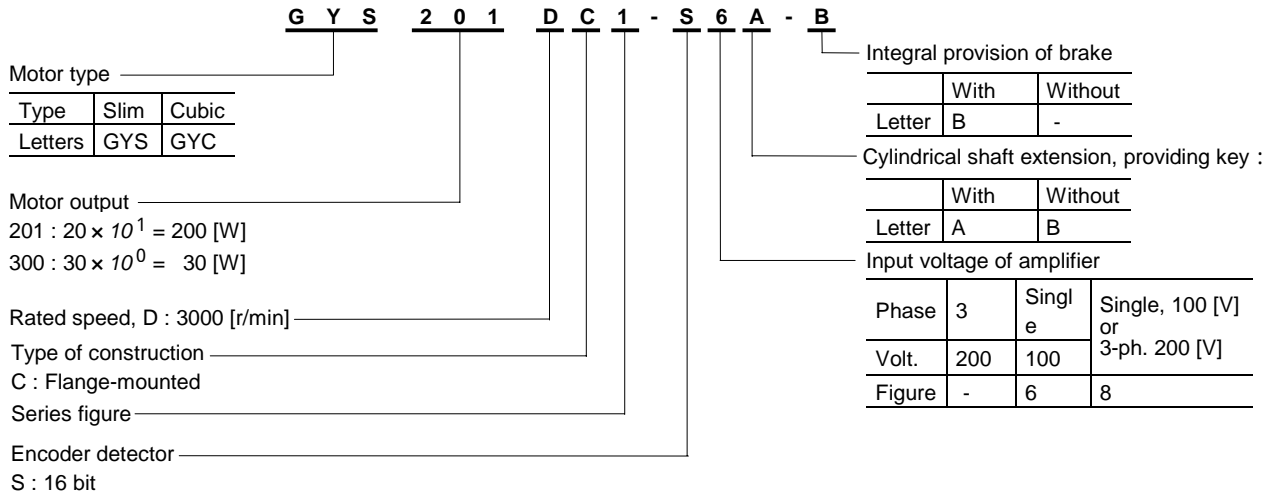

#### (c) Gear-head unit

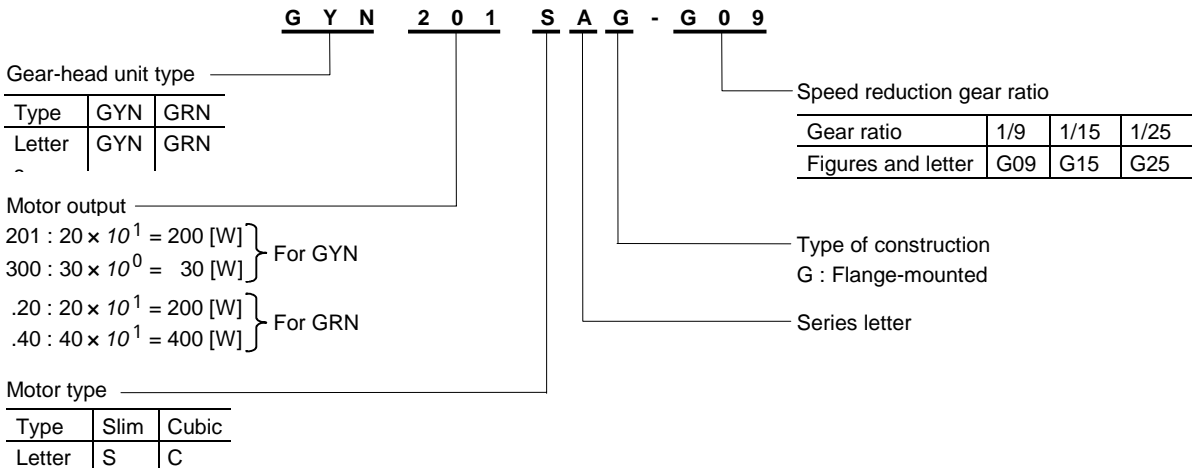

## 2. SPECIFICATIONS

### 2.1 Motor

#### (1) Cubic type motor (0.1 to 5 [kW])

(a) Basic design

(i) 0.1 to 1.5 [kW]

Type	GYC	DC1-SA	101	201	401	751	102	152
Rated output		[kW]	0.1	0.2	0.4	0.75	1	1.5
Rated torque		[N • m]	0.318	0.637	1.27	2.39	3.18	4.78
Speed	[r/min]	Rated	3000					
		Max.	5000					
Max. (breakdown) torque (*3)		[N • m]	0.955/1.43	1.91/2.87	3.82/5.73	7.17/10.7	9.55/12.7	14.3/19.1
Moment of inertia of motor rotor ( $\times 10^{-3}$ ) J		[kg • m <sup>2</sup> ]	0.00538	0.0216	0.0412	0.121	0.326	0.451
Current	[A]	Rated	1	1.5	2.6	4.8	6.7	9.7
		Max. (*3)	3/4.5	4.5/6.8	7.8/11.8	14.4/21.6	20.1/26.8	28.8/38.4
Winding insulation class	B						F	
Operation duty type	Continuous							
Degree of enclosure protection	Totally enclosed, IP55 except for shaft sealing							
Electrical connection terminals	Motor power		With 0.3 [m] flexible leads and connectors				With connectors	
	Encoder detector							
Temp. detection	Without providing							
Type of construction (mounting)	IMB5, IMV1, IMV3, flange-mounted							
Shaft extension, cylindrical	With key							
Final color for external non-machined surface	Munsell N1.5							
Pulse encoder	16-bit serial encoder							
Vibration level, peak to peak amplitude	5 [ $\mu$ m]						10 [ $\mu$ m] (*1)	
Install location	For indoors, 1000 [m] and below of site-altitude							
Ambient climatic conditions	Temperature : - 10 to +40°C, humidity : 90% RH max. (no condensation)							
Acceleration vibration, acceptable (max.)	[m/s <sup>2</sup> ]		49				24.5	
Mass (weight)		[kg]	0.75	1.3	1.9	3.5	5.7	7
External dimension	See (1) (a) of 3.3 External dimensions.							

(b) Additional data for motor with providing brake

(i) 0.1 to 1.5 [kW]

Type	GYC	DC1-SA-B	101	201	401	751	102	152
Rated output		[kW]	0.1	0.2	0.4	0.75	1	1.5
Rated torque		[N • m]	0.318	0.637	1.27	2.39	3.18	4.78
Braking torque		[N • m]	0.318	1.27		2.39	17	
Rated voltage DC		[V]	24					
Attraction time		[ms]	60	80		50	120	
Releasing time		[ms]	40			80	30	
Brake input		[W]	6.5	9		8.5	12	
Mass (weight)		[kg]	1	1.9	2.6	4.3	8	9.8
External dimension	See (1) (b) of 3.3 External dimensions.							

(c) Additional data for motor with providing reduction gear, gear head unit

(i) Motor with gear ratio 1/9

1) 0.1 to 1.5 [kW]

Type	GYN	CAG-G09	101	201	401	751	102	152
Motor output		[kW]	0.1	0.2	0.4	0.75	1	1.5
Actual reduction gear ratio			1/9					
Speed	[r/min]	Rated	333.3					
		Max.	555.5					
Rated torque		[N • m]	2.45	4.9	9.8	18.1	25.4	38.2
Max. (breakdown) torque		[N • m]	7.35	14.7	29.4	54.4	76.4	116
Direction of motor rotation (*2)			CCW					
Backlash (max.) (*4)		[min]	40	30				
Mass (weight)		[kg]	0.72	2.1	3.8	7.8		
External dimension			See (1) (e) of 3.3 External dimensions.					

(ii) Motor with gear ratio 1/25 or 1/15

1) 0.1 to 1.5 [kW]

Type	GYN	CAG-G25 or G15	101 G25	201	401	751	102 G15	152
Motor output		[kW]	0.1	0.2	0.4	0.75	1	1.5
Actual reduction gear ratio			1/25				1/15	
Speed	[r/min]	Rated	120				200	
		Max.	200				333.3	
Rated torque		[N • m]	6.37	12.7	25.5	48	39.2	57.8
Max. (breakdown) torque		[N • m]	19.1	38.2	76.4	144	117.6	173.4
Direction of motor rotation (*2)			CCW					
Backlash (max.) (*4)		[min]	40	30				
Mass (weight)		[kg]	0.72	2.1	3.8	7.8		
External dimension			See (1) (f) of 3.3 External dimensions.					

(\*1) 15 [μm] for over the rated speed.

(\*2) Direction of shaft rotation is CCW (counterclockwise), when motor shaft rotates forward (\*).  
The direction is viewed from a point facing the drive-end of motor.

(\*3) Max. (breakdown) torque and maximum current values are selected in accordance with the following paired combination of amplifier and motor types.

Lower value/higher value :

When the same output [kW] rating of amplifier and motor/when amplifier size is one step larger than the motor frame No. size corresponding with amplifier.

Refer to 2.3 Torque-speed data.

(\*4) Motor with 3 [min] backlash (max.) can be supplied, on request.

Note : (\*) The direction of motor rotation (when viewed from a point facing the drive-end of motor) is designed according to Japanese standards:

- Forward direction : Counterclockwise rotation (CCW)
- Reverse direction: Clockwise rotation (CW)

**(1) Cubic type motor (0.1 to 5 [kW]) (cont'd)**

(a) Basic design

(ii) 2 to 5 [kW]

Type	GYC	DC1-SA	202	302	402	502
Rated output		[kW]	2	3	4	5
Rated torque		[N • m]	6.37	-	-	-
Speed	[r/min]	Rated	3000			
		Max.	5000			
Max. (breakdown) torque		[N • m]	19.1	-	-	-
Moment of inertia of motor rotor ( $\times 10^{-3}$ ) J		[kg • m <sup>2</sup> ]	0.575	-	-	-
Current	[A]	Rated	12.6	-	-	-
		Max.	37.8	-	-	-
Winding insulation class	F					
Operation duty type	Continuous					
Degree of enclosure protection	Totally enclosed, IP55 except for shaft sealing					
Electrical connection terminals	Motor power	With connectors				
	Encoder detector					
Temp. detection	Without providing					
Type of construction (mounting)	IMB5, IMV1, IMV3, flange-mounted					
Shaft extension, cylindrical	With key					
Final color for external non-machined surface	Munsell N1.5					
Pulse encoder	16-bit serial encoder					
Vibration level, peak to peak amplitude	10 [ $\mu$ m] (*1)					
Install location	For indoors, 1000 [m] and below of site-altitude					
Ambient climatic conditions	Temperature : - 10 to +40 , humidity : 90% RH max. (no condensation)					
Acceleration vibration, acceptable (max.)		[m/s <sup>2</sup> ]	24.5			
Mass (weight)		[kg]	8.2	-	-	-
External dimension	See (1) (a) of 3.3 External dimensions.					

(b) Additional data for motor with providing brake

(ii) 2 to 5 [kW]

Type	GYC	DC1-SA-B	202	302	402	502
Rated output		[kW]	2	3	4	5
Rated torque		[N • m]	3.18	-	-	-
Braking torque		[N • m]	17	-	-	-
Rated voltage DC		[V]	24			
Attraction time		[ms]	120	-	-	-
Releasing time		[ms]	30	-	-	-
Brake input		[W]	12	-	-	-
Mass (weight)		[kg]	11			
External dimension	See (1) (b) of 3.3 External dimensions.					

(c) Additional data for motor with providing reduction gear, gear head unit

(i) Motor with gear ratio 1/9

2) 2 to 5 [kW]

Type	GYN	CAG-G09	202	302	402	502
Motor output		[kW]	2	3	4	5
Actual reduction gear ratio			1/9	-		
Speed [r/min]	Rated		333.3	-		
	Max.		555.5	-		
Rated torque		[N • m]	50.9	-	-	-
Max. (breakdown) torque		[N • m]	152	-	-	-
Direction of motor rotation (*2)			CCW			
Backlash (max.) (*4)		[min]	30	-	-	-
Mass (weight)		[kg]	12.2	-	-	-
External dimension			See (1) (e) of 3.3 External dimensions.			

(ii) Motor with gear ratio 1/25 or 1/15

2) 2 to 5 [kW]

Type	GYN	CAG-G15	202	302	402	502
Motor output		[kW]	2	3	4	5
Actual reduction gear ratio			1/15	-		
Speed [r/min]	Rated		200	-		
	Max.		333.3	-		
Rated torque		[N • m]	77.4	-	-	-
Max. (breakdown) torque		[N • m]	232	-	-	-
Direction of motor rotation (*2)			CCW			
Backlash (max.) (*4)		[min]	30	-	-	-
Mass (weight)		[kg]	12.2	-	-	-
External dimension			See (1) (f) of 3.3 External dimensions.			

(\*1) 15 [μm] for over the rated speed.

(\*2) Direction of shaft rotation is CCW (counterclockwise), when motor shaft rotates forward.  
The direction is viewed from a point facing the drive-end of motor.

(\*4) Motor with 3 [min] backlash (max.) can be supplied, on request.

**(2) Slim type motor (0.03 to 5 [kW]) for 200 [V] class input voltage of amplifier**

(a) Basic design

(i) 0.03 to 0.75 [kW]

Type	GYS DC1- S8B, SB or SA	300 S8B	500	101 SB	201 SA	401	751
Rated output	[kW]	0.03	0.05	0.1	0.2	0.4	0.75
Rated torque	[N • m]	0.095	0.159	0.318	0.637	1.27	2.39
Speed	[r/min] Rated	3000					
	Max.	5000					
Max. (breakdown) torque (*3)	[N • m]	0.287	0.478	0.955	1.91/2.87	3.82/5.73	7.17/10.7
Moment of inertia of motor rotor ( $\times 10^{-3}$ ) J[ $\text{kg} \cdot \text{m}^2$ ]		0.00253	0.00341	0.00517	0.0137	0.0249	0.0861
Current	[A] Rated	0.6	0.93	0.9	1.5	2.6	4.8
	Max. (*3)	1.8	2.8	2.7	4.5/6.8	7.8/11.8	14.4/21.6
Winding insulation class		B					
Operation duty type		Continuous					
Degree of enclosure protection		Totally enclosed, IP55 except for shaft sealing					
Electrical connection terminals	Motor power	With 0.3 [m] flexible leads and connectors					
	Encoder detector						
Temp. detection		Without providing					
Type of construction (mounting)		IMB5, IMV1, IMV3, flange-mounted					
Shaft extension, cylindrical		Without key (*5)				With key	
Final color for external non-machined surface		Munsell N1.5					
Pulse encoder		16-bit serial encoder					
Vibration level, peak to peak amplitude		5 [ $\mu\text{m}$ ]					
Install location		For indoors, 1000 [m] and below of site-altitude					
Ambient climatic conditions		Temperature : - 10 to +40°C, humidity : 90% RH max. (no condensation)					
Acceleration vibration, acceptable (max.)	[ $\text{m}/\text{s}^2$ ]	49					
Mass (weight)	[kg]	0.4	0.45	0.55	1.2	1.8	3.4
External dimension		See (1) (g) of 3.3 External dimensions.					

(b) Additional data for motor with providing brake

(i) 0.03 to 0.75 [kW]

Type	GYS DC1- S8B-B, SB-B or SA-B	300 S8B-B	500	101 SB-B	201 SA-B	401	751
Rated output	[kW]	0.03	0.05	0.1	0.2	0.4	0.75
Rated torque	[N • m]	0.095	0.159	0.318	0.637	1.27	2.39
Braking torque	[N • m]	-	0.3		1.27		2.45
Rated voltage DC	[V]	-	24				
Attraction time	[ms]	-	35		40		60
Releasing time	[ms]	-	10		20		25
Brake input	[W]	-	6.1		7.3		8.5
Mass (weight)	[kg]	-	0.62	0.72	1.7	2.3	4.2
External dimension		See (1) (h) of 3.3 External dimensions.					

(c) Additional data for motor with providing reduction gear, gear head unit

(i) Motor with gear ratio 1/9

1) 0.03 to 0.75 [kW]

Type	SAG-G09	GYN			GRN		GYN
		300	500	101	.20	.40	751
Motor output	[kW]	0.03	0.05	0.1	0.2	0.4	0.75
Actual reduction gear ratio		-	1/9				
Speed	[r/min]	-	333.3				
	Rated						
	Max.	-	555.5				
Rated torque	[N • m]	-	1.23	2.54	4.9	9.8	18.1
Max. (breakdown) torque	[N • m]	-	3.68	7.36	14.7	29.4	54.3
Direction of motor rotation (*2)		-	CCW				
Backlash (max.) (*4)	[min]	-	40		30		
Mass (weight)	[kg]	-	0.7		2.1		3.8
External dimension		See (1) (k) of 3.3 External dimensions.					

(ii) Motor with gear ratio 1/25 or 1/15

1) 0.03 to 0.75 [kW]

Type	SAG-G25	GYN			GRN		GYN
		300	500	101	.20	.40	751
Motor output	[kW]	0.03	0.05	0.1	0.2	0.4	0.75
Actual reduction gear ratio		-	1/25				
Speed	[r/min]	-	120				
	Rated						
	Max.	-	200				
Rated torque	[N • m]	-	3.19	6.37	12.7	25.5	48
Max. (breakdown) torque	[N • m]	-	9.56	19.1	38.2	76.4	144
Direction of motor rotation (*2)		-	CCW				
Backlash (max.) (*4)	[min]	-	40		30		
Mass (weight)	[kg]	-	0.7		2.1		3.8
External dimension		See (1) (l) of 3.3 External dimensions.					

(\*2) Direction of shaft rotation is CCW (counterclockwise), when motor shaft rotates forward.

The direction is viewed from a point facing the drive-end of motor.

(\*3) Max. (breakdown) torque and maximum current values are selected in accordance with the following paired combination of amplifier and motor types.

Lower value/higher value :

When the same output [kW] rating of amplifier and motor/when amplifier size is one step larger than the motor frame No. size corresponding with amplifier.

Refer to 2.3 Torque-speed data.

(\*4) Motor with 3 [min] backlash (max.) can be supplied, on request.

(\*5) When a motor with GYN or GRN type gear-head unit is supplied, the shaft extension of this motor is provided with a key.

**(2) Slim type motor (0.03 to 5 [kW]) for 200 [V] class input voltage of amplifier (cont'd)**

(a) Basic design

(ii) 1 to 5 [kW]

Type	GYS	DC1-SA	102	152	202	302	402	502
Rated output		[kW]	1	1.5	2	3	4	5
Rated torque		[N • m]	3.18	4.78	6.37	9.55	12.7	15.9
Speed	[r/min]	Rated	3000					
		Max.	5000					
Max. (breakdown) torque (*3)		[N • m]	9.55/12.7	14.3/19.1	19.1	28.7	38.2	47.8
Moment of inertia of motor rotor( × 10 <sup>-3</sup> ) J[kg • m <sup>2</sup> ]			0.174	0.238	0.302	0.873	1.12	1.37
Current	[A]	Rated	7.1	9.6	12.6	18.5	24.5	30
		Max. (*3)	21.3/28.4	28.8/38.4	37.8	55.5	73.5	90
Winding insulation class	F							
Operation duty type	Continuous							
Degree of enclosure protection	Totally enclosed, IP55 except for shaft sealing							
Electrical connection terminals	Motor power		With connectors					
	Encoder detector							
Temp. detection	Without providing							
Type of construction (mounting)	IMB5, IMV1, IMV3, flange-mounted							
Shaft extension, cylindrical	With key							
Final color for external non-machined surface	Munsell N1.5							
Pulse encoder	16-bit serial encoder							
Vibration level, peak to peak amplitude	10 [μm] (*1)							
Install location	For indoors, 1000 [m] and below of site-altitude							
Ambient climatic conditions	Temperature : - 10 to +40°C, humidity : 90% RH max. (no condensation)							
Acceleration vibration, acceptable (max.)	24.5 [m/s <sup>2</sup> ]							
Mass (weight)		[kg]	4.4	5.2	6.3	11	13.5	16
External dimension	See (1) (g) of 3.3 External dimensions.							

(b) Additional data for motor with providing brake

(ii) 1 to 5 [kW]

Type	GYS	DC1-SA-B	102	152	202	302	402	502
Rated output		[kW]	1	1.5	2	3	4	5
Rated torque		[N • m]	3.18	4.78	6.37	9.55	12.7	15.9
Braking torque		[N • m]	6.86		17			
Rated voltage DC		[V]	24					
Attraction time		[ms]	60		120			
Releasing time		[ms]	10		30			
Brake input		[W]	17		12			
Mass (weight)		[kg]	5.9	6.8	7.9	13	15.5	18
External dimension	See (1) (h) of 3.3 External dimensions.							

(c) Additional data for motor with providing reduction gear, gear head unit

(ii) Motor with gear ratio 1/9

2) 1 to 5 [kW]

Type	GYN	SAG-G09	102	152	202	302	402	502
Motor output		[kW]	1	1.5	2	3	4	5
Actual reduction gear ratio			1/9					
Speed	[r/min]	Rated	333.3					
		Max.	555.5					
Rated torque		[N • m]	25.4	38.2	50.9	-	-	-
Max. (breakdown) torque		[N • m]	74.4	114	152	-	-	-
Direction of motor rotation (*2)			CCW					
Backlash (max.) (*4)		[min]	30			-	-	-
Mass (weight)		[kg]	7.8			-	-	-
External dimension			See (1) (k) of 3.3 External dimensions.					

(ii) Motor with gear ratio 1/25 or 1/15

2) 1 to 5 [kW]

Type	GYN	SAG-G15	102	152	202	302	402	502
Motor output		[kW]	1	1.5	2	3	4	5
Actual reduction gear ratio			1/15					
Speed	[r/min]	Rated	200			-		
		Max.	333.3			-		
Rated torque		[N • m]	39.2	57.8	77.4	-	-	-
Max. (breakdown) torque		[N • m]	117	173	232	-	-	-
Direction of motor rotation (*2)			CCW					
Backlash (max.) (*4)		[min]	30			-	-	-
Mass (weight)		[kg]	7.8			-	-	-
External dimension			See (1) (l) of 3.3 External dimensions.					

(\*1) 15 [μm] for over the rated speed.

(\*2) Direction of shaft rotation is CCW (counterclockwise), when motor shaft rotates forward.

The direction is viewed from a point facing the drive-end of motor.

(\*3) Max. (breakdown) torque and maximum current values are selected in accordance with the following paired combination of amplifier and motor types.

Lower value/higher value :

When the same output [kW] rating of amplifier and motor/when amplifier size is one step larger than the motor frame No. size corresponding with amplifier.

Refer to 2.3 Torque-speed data.

(\*4) Motor with 3 [min] backlash (max.) can be supplied, on request.

**(3) Slim type motor (0.03 to 0.2 [kW]) for 100 [V] class input voltage of amplifier**

**(a) Basic design**

Type	GYS DC1-S6B or S8B	300 S8B	500	101 S6B	201
Rated output	[kW]	-	0.05	0.1	0.2
Rated torque	[N • m]	-	0.159	0.318	0.637
Speed	[r/min] Rated	-	3000		
	Max.	-	5000		
Max. (breakdown) torque	[N • m]	-	0.478	0.955	1.91
Moment of inertia of motor rotor ( $\times 10^{-3}$ ) J	[kg • m <sup>2</sup> ]	-	0.00341	0.00517	0.0137
Current	[A] Rated	-	0.85	1.5	2.7
	Max.	-	2.55	4.5	8.1
Winding insulation class		B			
Operation duty type		Continuous			
Degree of enclosure protection		Totally enclosed, IP55 except for shaft sealing			
Electrical connection terminals	Motor power	With 0.3 [m] flexible leads and connectors			
	Encoder detector				
Temp. detection		Without providing			
Type of construction (mounting)		IMB5, IMV1, IMV3, flange-mounted			
Shaft extension, cylindrical		Without key (*5)			
Final color for external non-machined surface		Munsell N1.5			
Pulse encoder		16-bit serial encoder			
Vibration level, peak to peak amplitude		5 [ $\mu$ m]			
Install location		For indoors, 1000 [m] and below of site-altitude			
Ambient climatic conditions		Temperature : - 10 to +40°C, humidity : 90% RH max. (no condensation)			
Acceleration vibration, acceptable (max.)	[m/s <sup>2</sup> ]	49			
Mass (weight)	[kg]	-	0.45	0.55	1.2
External dimension		See (2) (a) of 3.3 External dimensions.			

**(b) Additional data for motor with providing brake**

Type	GYS DC1-S6B-B or S8B-B	300 S8B-B	500	101 S6B-B	201
Rated output	[kW]	0.03	0.05	0.1	0.2
Rated torque	[N • m]	-	0.159	0.318	0.637
Braking torque	[N • m]	-	0.34		1.27
Rated voltage DC	[V]	-	24		
Attraction time	[ms]	-	35		40
Releasing time	[ms]	-	10		20
Brake input	[W]	-	6.1		7.3
Mass (weight)	[kg]	-	0.62	0.72	1.7
External dimension		See (2) (b) of 3.3 External dimensions.			

**(c) Additional data for motor with providing reduction gear, gear-head unit**

**(i) Motor with gear ratio 1/9**

Type	SAG-G09	GYN	GRN	
		300	.20	
Rated output	[kW]	0.03	0.2	
Actual reduction gear ratio		1/9		
Speed	[r/min] Rated	-	333.3	
	Max.	-	555.5	
Rated torque	[N • m]	-	1.23	4.9
Max. (breakdown) torque	[N • m]	-	3.68	14.7
Direction of motor rotation (*2)		-	CCW	
Backlash (max.) (*4)	[N • m]	-	40	30
Mass (weight)	[kg]	-	0.7	2.1
External dimension		See (1) (k) of 3.3 External dimensions.		

(c) Additional data for motor with providing reduction gear, gear-head unit (cont'd)

(ii) Motor with gear ratio 1/25

Type		SAG-G25	GYN			GRN
			300	500	101	.20
Rated output	[kW]		0.03	0.05	0.1	0.2
Actual reduction gear ratio			1/25			
Speed	[r/min]	Rated	-	120		
		Max.	-	200		
Rated torque	[N • m]		-	3.19	6.37	12.7
Max. (breakdown) torque	[N • m]		-	9.56	19.1	38.2
Direction of motor rotation (*2)			-	CCW		
Backlash (max.) (*4)	[min]		-	40	30	
Mass (weight)	[kg]		-	0.7	2.1	
External dimension			See (1) (l) of 3.3 External dimensions.			

(\*2) Direction of shaft rotation is CCW (counterclockwise), when motor shaft rotates forward.

The direction is viewed from a point facing the drive-end of motor.

(\*4) Motor with 3 [min] backlash (max.) can be supplied, on request.

(\*5) When a motor with GYN or GRN type gear-head unit is supplied, the shaft extension of this motor is provided with a key.

## 2.2 Amplifier

### (1) Basic specification for 200 [V] input voltage of amplifier

(a) 0.03 to 0.75 [kW]

Amplifier type	RYS	S3-LPS	300	500	101	201	401	751
Applicable motor output (*1)		[kW]	0.03	0.05	0.1	0.2	0.4	0.75
Input	Phase, freq.		3-phase for power supply, single-phase for control, 50/60 [Hz]					
	Voltage		200/200-220-230 [V], +10 to - 15%					
Control data	System		Sinusoidal wave PWM current control (all digital)					
	Carrier freq.		[kHz] 10					
	Feedback		16 bit serial encoder (one-rotation resolution 16 bit, multiple-rotation 16 bit)					
	Speed control accuracy	Loading	$\pm 1$ [r/min]	for 0 to 100% deviation				
		Supply volt.	max.	For - 10 to +10% fluctuation				
		Amb. temp.	$\pm 0.2\%$ max. for 25°C $\pm 10\%$ variation (at analog volt. input)					
	Speed range		1 : 5000 (at rated load)					
	Freq. response		600 [Hz] (at $J_L = J_M$ (*2))					
	Load inertia. max.		100 times of the motor rotor inertia, permissible					
	Overload capability		300% for approx. 3 [s]				300% for approx. 3 [s], 450% for approx. 1.5 [s]	
Function	Braking		Regenerating, dynamic with external braking resistor					
	Protection		OC (output overcurrent), OS (overspeed), $L_V$ (low voltage, undervoltage), $H_V$ (high voltage, overvoltage), Et (encoder trouble), Ct (circuit trouble, amplifier trouble), dE (data error, memory error), CE (combination error), rH <sub>2</sub> (resistor heat 2), EC (encoder communication error), CtE (cont (control signal) error), OL (motor overload), rH (resistor heat, braking (OB) resistor overheat), OF (over flow, deviation excessive), AH (amp. heat, amplifier overheat), EH (encoder heat, encoder overheat), AL (absolute data lost), AF (absolute data over flow), Fb (fuse blown)					
	Display, setting		CHARGE (red), 7-segment LED with 5 digit and 4 operation keys					
Ambient condition	Install location		For indoors, 1000 [m] and below of site-altitude, under clean atmosphere, no explosive hazardous gas and vapour is existing. In the case of compliance with the European standard : Pollution degree = 2, Over voltage category =					
	Temp., humidity		- 10 to +55°C, 90% RH max. (no condensation)					
	Vibration / shock		4.9 [m/s <sup>2</sup> ] / 19.6 [m/s <sup>2</sup> ] acceleration, acceptable (max.)					
Others		DC reactor terminals (P1, P+) for harmonics suppression. UL/cUL (compliance with UL508), European standards (compliance with EN50178)						
Mass (weight)		[kg]	0.9				1.2	1.5

(\*1) Use amplifier and motor as a specified pair of types.

Fox GYC type motor with 0.1 to 1.5 [kW] or GYS type motor with 0.2 to 1.5 [kW] rated output :

If the RYS401 (0.4 [kW]) type amplifier and GYS201 (0.2 [kW]) motor (which is a step smaller than the optimum combination) is combined as a pair, allowable max. (breakdown) torque of 0.2 [kW] motor can be obtained as 450% (in the case of the max. torque of the motor is 450%) of the rated torque.

Furthermore, in this case, other data are as follows :

- The moment of load inertia after conversion into motor shaft extension is at most 30 times the moment of inertia of motor rotor.
- Acceleration/deceleration time up to rated speed is 2 [ms] or more.
- The motor shaft extension is directly mechanically connected and is subjected to no external radial or thrust force.

(\*2) Moment of inertia

$J_L$  : Moment of load inertia after conversion into motor shaft extension

$J_M$  : Moment of inertia of motor rotor

(b) 1 to 5 [kW]

Amplifier type	RYS	S3-LPS	102	152	202	302	402	502
Applicable motor output (*1)		[kW]	1	1.5	2	3	4	5
Input	Phase, freq.	3-phase for power supply, single-phase for control, 50/60 [Hz]						
	Voltage	200/200-220-230 [V], +10 to - 15%						
Control data	System	Sinusoidal wave PWM current control (all digital)						
	Carrier freq.	[kHz]	10	5				
	Feedback	16 bit serial encoder (one-rotation resolution 16 bit, multiple-rotation 16 bit)						
	Speed control accuracy	Loading	± 1 [r/min]	for 0 to 100% deviation				
		Supply volt.	max.	For - 10 to +10% fluctuation				
		Amb. temp.	± 0.2% max. for 25°C ± 10% variation (at analog volt. input)					
	Speed range	1 : 5000 (at rated load)						
	Freq. response	600 [Hz] (at $J_L = J_M$ (*2) )						
	Load inertia. max.	100 times of the motor rotor inertia, permissible						
	Overload capability	300% for approx. 3 [s], 450% for approx. 1.5 [s]					300% for approx. 3 [s]	
Function	Braking	Regenerating, dynamic with external braking resistor						
	Protection	OC (output overcurrent), OS (overspeed), $L_V$ (low voltage, undervoltage), $H_V$ (high voltage, overvoltage), Et (encoder trouble), Ct (circuit trouble, amplifier trouble), dE (data error, memory error), CE (combination error), $rH_2$ (resistor heat 2), EC (encoder communication error), CtE (cont (control signal) error), OL (motor overload), rH (resistor heat, braking (OB) resistor overheat), OF (over flow, deviation excessive), AH (amp. heat, amplifier overheat), EH (encoder heat, encoder overheat), AL (absolute data lost), AF (absolute data over flow) , Fb (fuse blown) for 2 [kW] and more						
	Display, setting	CHARGE (red), 7-segment LED with 5 digit and 4 operation keys						
Ambient condition	Install location	For indoors, 1000 [m] and below of site-altitude, under clean atmosphere, no explosive hazardous gas and vapour is existing. In the case of compliance with the European standard : Pollution degree = 2, Over voltage category =						
	Temp., humidity	- 10 to +55°C, 90% RH max. (no condensation)						
	Vibration / shock	4.9 [m/s <sup>2</sup> ] / 19.6 [m/s <sup>2</sup> ] acceleration, acceptable (max.)						
Others	DC reactor terminals (P1, P+) for harmonics suppression. UL/cUL (compliance with UL508), European standards (compliance with EN50178)							
Mass (weight)		[kg]	2	4.6	4.7	5.2		

(\*1) Use amplifier and motor as a specified pair of types.

Fox GYC type motor with 0.1 to 1.5 [kW] or GYS type motor with 0.2 to 1.5 [kW] rated output :

If the RYS401 (0.4 [kW]) type amplifier and GYS201 (0.2 [kW]) motor (which is a step smaller than the optimum combination) is combined as a pair, allowable max. (breakdown) torque of 0.2 [kW] motor can be obtained as 450% (in the case of the max. torque of the motor is 450%) of the rated torque.

Furthermore, in this case, other data are as follows :

- The moment of load inertia after conversion into motor shaft extension is at most 30 times the moment of inertia of motor rotor.
- Acceleration/deceleration time up to rated speed is 2 [ms] or more.
- The motor shaft extension is directly mechanically connected and is subjected to no external radial or thrust force.

(\*2) Moment of inertia

$J_L$  : Moment of load inertia after conversion into motor shaft extension

$J_M$  : Moment of inertia of motor rotor

**(2) Basic specification for 100 [V] class input voltage of amplifier**

0.05 to 0.2 [kW]

Amplifier type	RYS	S3-LPS6	500	101	201
Applicable motor output (*1)		[kW]	0.05	0.1	0.2
Input	Phase, freq.		Single-phase for power supply, for control, 50/60 [Hz]		
	Voltage		100 to 115 [V], +10 to - 15%		
Control data	System		Sinusoidal wave PWM current control (all digital)		
	Carrier freq.		[kHz] 10		
	Feedback		16-bit serial encoder (one-rotation resolution 16 bit, multiple-rotation 16 bit)		
	Speed control accuracy	Loading	± 1 [r/min]	for 0 to 100% deviation	
		Supply volt.	max.	For - 10 to +10% fluctuation	
		Amb. temp.	± 0.2% max. for 25°C ± 10% variation (at analog volt. input)		
	Speed range		1 : 5000 (at rated load)		
	Freq. response		600 [Hz] (at $J_L = J_M$ (*2) )		
	Load inertia. max.		100 times of the motor rotor inertia, permissible		
	Overload capability		300% for approx. 3 [s]		
Function	Braking		Regenerating, dynamic with external braking resistor		
	Protection		OC (output overcurrent), OS (overspeed), $L_V$ (low voltage, undervoltage), $H_V$ (high voltage, overvoltage), Et (encoder trouble), Ct (circuit trouble, amplifier trouble), dE (data error, memory error), CE (combination error), $rH_2$ (resistor heat 2), EC (encoder communication error), CtE (cont (control signal) error), OL (motor overload), rH (resistor heat, braking (OB) resistor overheat), OF (over flow, deviation excessive), AH (amp. heat, amplifier overheat), EH (encoder heat, encoder overheat), AL (absolute data lost), AF (absolute data over flow)		
	Display, setting		CHARGE (red), 7-segment LED with 5 digit and 4 operation keys		
Ambient condition	Install location		For indoors, 1000 [m] and below of site-altitude, under clean atmosphere, no explosive hazardous gas and vapour is existing. In the case of compliance with the European standard : Pollution degree = 2, Over voltage category =		
	Temp., humidity		- 10 to +55°C, 90% RH max. (no condensation)		
	Vibration / shock		4.9 [m/s <sup>2</sup> ] / 19.6 [m/s <sup>2</sup> ] acceleration, acceptable (max.)		
Others		DC reactor terminals (P1, P+) for harmonics suppression. UL/cUL (compliance with UL508), European standards (compliance with EN50178)			
Mass (weight)		[kg]	0.9	1.2	

(\*1) Use amplifier and motor as a specified pair of types : For example, "RYS500" type amplifier can be combined with the acceptable "GYS500" type motor only.

(\*2) Moment of inertia

$J_L$  : Moment of load inertia after conversion into motor shaft extension

$J_M$  : Moment of inertia of motor rotor

**(3) Functional specification : Basic design, RYS S3-LPS type amplifier**

Signal name	Function	Terminal symbol
Host interface (I/F)	DI/DO (+24 [V] DC)	-
Pulse train	Input	Freq. 500 [kHz] max. (differential input)
	Form	(1) Command pulse and code, (2) Forward and reverse pulse, (3) Two 90° phase-different signal
Freq. dividing output	Output	Freq. 500 [kHz] max. (differential output)
	Form	Two 90° phase-different signal
	Pulse	16 to 16384 [pulse/rev] (in 1 step)
Speed command	Power supply	+10 ± 0.4 [V] (output current 30 [mA] max.)
	Input	± 10 [V] (20 k input impedance)
Monitor output 1/2	For analog-meter (two/one-way deflection), (1) Speed command, (2) Speed feedback, (3) Torque command, (4) Position deviation	MON1 MON2
Power supply for I/F	+24 [V] DC, 300 [mA] (supplied from external)	P24, M24
Control input	+24 [V] DC, 10 [mA] (one-point) source input Signal assign terminals of control input	CONT1 to CONT13
OUT output	+30 [V] DC, 50 [mA] max. sink output Signal assign terminals of control output	OUT1 to OUT10
External backup	Input terminals of backup power supply from external to encoder	BAT+, BAT -
<b>Control function</b>		
Position control	<ul style="list-style-type: none"> <li>• Auto start (address specify, sequential starting, immediately positioning)</li> <li>• Manual run (analog voltage, multistep speed, interrupt positioning)</li> <li>• Pulse train input, origin return (4 pattern)</li> </ul>	
Origin setting	LS (origin limit switch) and Z-phase, position preset	
Position data	99-point (position, speed, timer, M-code and statuses)	
Position command, max.	± 79,999,999 (x unit q'ty)	
Others	Override, brake timing output, etc.	

**(4) Functional specification : SX bus type design, RYS S3-LSS type amplifier**

Signal name	Function	Terminal symbol
Host interface (I/F)	SX bus (IQ area, 16 word)	(IN, OUT)
Pulse train	Input	Freq. 500 [kHz] max. (differential input)
	Form	(1) Command pulse and code, (2) Forward and reverse pulse, (3) Two 90° phase-different signal
	Power supply	5 [V] DC, 200 [mA] (max.)
Freq. dividing output	Output	Freq. 500 [kHz] max. (differential output)
	Form	Two 90° phase-different signal
	Pulse	16 to 16384 [pulse/rev] (in 1 step)
Monitor output 1/2	For analog-meter (two/one-way deflection), (1) Speed command, (2) Speed feedback, (3) Torque command, (4) Position deviation	MON1 MON2
Power supply for I/F	+24 [V] DC, 300 [mA] (supplied from external)	P24, M24
Control input	+24 [V] DC, 10 [mA] (one-point) source input External control input terminals	CONT1 to CONT5
OUT output	+30 [V] DC, 50 [mA] max. sink output External control output terminals	OUT1 and OUT2
External backup	Input terminals of backup power supply from external to encoder	BAT+, BAT -
<b>Control function</b>		
Position control	<ul style="list-style-type: none"> <li>• Auto start (address specify, sequential starting, immediately positioning)</li> <li>• Manual run (multistep speed, interrupt positioning), pulse train input, origin return (4 pattern)</li> </ul>	
Origin setting	LS (origin limit switch) and Z-phase, position preset	
Position data	99-point (position, speed, timer, M-code and statuses)	
Position command, max.	± 79,999,999 (x unit q'ty)	
Others	Override, brake timing output, etc.	

**(5) Functional specification : T-link type design, RYS S3-LTS type amplifier**

Signal name	Function		Terminal symbol
Host interface (I/F)	T-link (WB area, 8 word)		T2, T1, SD
Pulse train	Input	Freq. 500 [kHz] max. (differential input)	CA, *CA CB, *CB
	Form	(1) Command pulse and code, (2) Forward and reverse pulse, (3) Two 90° phase-different signal	
	Power supply	5 [V] DC, 200 [mA] (max.)	P5
Freq. dividing output	Output	Freq. 200 [kHz] max. (open collector)	FA, FB, FZ
	Form	Two 90° phase-different signal	
	Pulse	16 to 16384 [pulse/rev] (in 1 step)	
Monitor output 1/2	For analog-meter (two/one-way deflection), (1) Speed command, (2) Speed feedback, (3) Torque command, (4) Position deviation		MON1 MON2
Power supply for I/F	+24 [V] DC, 300 [mA] (supplied from external)		P24, M24
Control input	+24 [V] DC, 10 [mA] (one-point) source input External control input terminals		CONT1 to CONT8
OUT output	+30 [V] DC, 50 [mA] max. sink output External control output terminals		OUT1 to OUT4
External backup	Input terminals of backup power supply from external to encoder		BAT+, BAT -
<b>Control function</b>			
Position control	Auto start (address specify, sequential starting, immediately positioning) Manual run (analog voltage, multistep speed, interrupt positioning), pulse train input, origin return (4 pattern)		
Origin setting	LS (origin limit switch) and Z-phase, position preset		
Position data	99-point (position, speed, timer, M-code and statuses)		
Position command, max.	± 79,999,999 (x unit q'ty)		
Others	Override, brake timing output, etc.		

**(6) Functional specification : General-purpose communication (RS485 interface) type design, RYS S3-LRS type amplifier**

Signal name	Function		Terminal symbol
Host interface (I/F)	RS485 (4-wire half-duplex/31 stations, max.)		-
Pulse train	Input	Freq. 500 [kHz] max. (differential input)	CA, *CA CB, *CB
	Form	(1) Command pulse and code, (2) Forward and reverse pulse, (3) Two 90° phase-different signal	
	Power supply	5 [V] DC, 200 [mA] (max.)	P5
Freq. dividing output	Output	Freq. 200 [kHz] max. (differential output)	FA, FB, FZ
	Form	Two 90° phase-different signal	
	Pulse	16 to 16384 [pulse/rev] (in 1 step)	
Monitor output 1/2	For analog-meter (two/one-way deflection), (1) Speed command, (2) Speed feedback, (3) Torque command, (4) Position deviation		MON1 MON2
Power supply for I/F	+24 [V] DC, 300 [mA] (supplied from external)		P24, M24
Control input	+24 [V] DC, 10 [mA] (one-point) source input External control input terminals		CONT1 to CONT8
OUT output	+30 [V] DC, 50 [mA] max. sink output External control output terminals		OUT1 to OUT4
External backup	Input terminals of backup power supply from external to encoder		BAT+, BAT -
<b>Control function</b>			
Position control	Auto start (address specify, immediately positioning) Manual run (multistep speed, interrupt positioning), pulse train input, origin return (4 pattern)		
Origin setting	LS (origin limit switch) and Z-phase, position preset		
Position data	99-point (position, speed, timer, M-code and statuses)		
Position command, max.	± 79,999,999 (x unit q'ty)		
Others	Override, brake timing output, etc.		

### (7) Optional cables, connection kits, battery and external braking resistors

See (3) of 4.1 Amplifier, motor and optional devices layout, and 10.8 Optional cables, connector kits, battery and external braking resistors.

### 2.3 Torque-speed data

Shown below are the torque characteristic with each motor and amplifier combination.

(a) Within the range of “(A) Acceleration/deceleration area 1” and “(B) Acceleration/deceleration area 2” are used for accel./decel. (\*) the motor.

(i) **(A) Acceleration/deceleration area 1** : Output torque is available at accel./decel. In case of the same output [kW] rating of the amplifier and motor combination.

(ii) **(B) Acceleration/deceleration area 2** : Output torque is available at accel./decel. When the amplifier size is one step larger than the motor frame No. size corresponding with the amplifier. See (3) (d) of 10.3 Combination error.

(iii) In the case of (A) and (B), a torque higher than rated cannot be outputted continuously.

(b) Within the range of “**(C) Continuous operation area**”, the motor can continuously be operated (at rated speed or lower). Above the rated speed, the rated torque cannot be outputted continuously.

(c) The overload detecting time (guidepost) is as follows.

Output torque [%]	100 (rated torque)	125	150	200	300	450
Overload detecting time approx. [s]	Continuous operation is acceptable.	35	18	9	3	1.5

Before tripping by overload, an early warning signal can be outputted. See 5.6.6 Overload early warning.

Note : (\*) Accel. : Accelerating or acceleration  
Decel. : Decelerating or deceleration

(1) GYC motor, cubic type, for 200 [V] class input voltage of amplifier

• GYC 101DC1 - SA ( 0.1 [kW] )

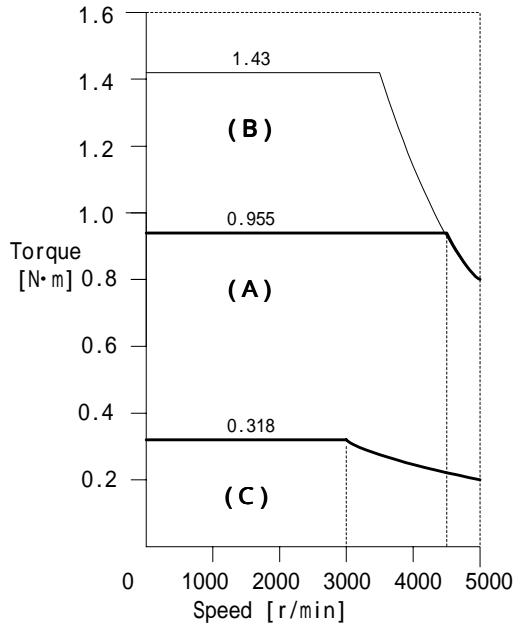

• GYC 201DC1 - SA ( 0.2 [kW] )

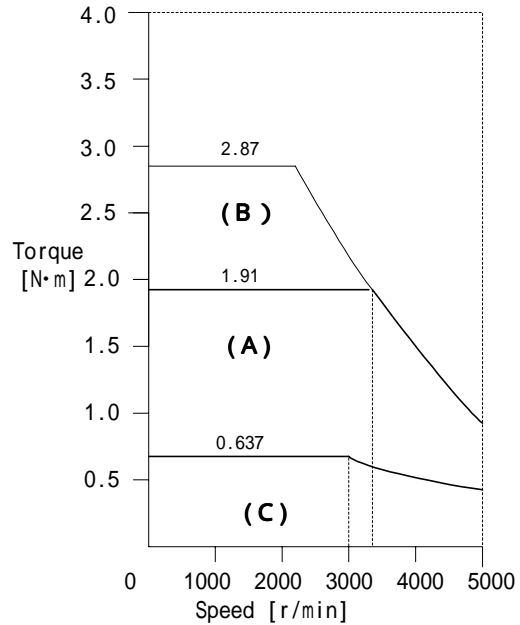

• GYC 401DC1 - SA ( 0.4 [kW] )

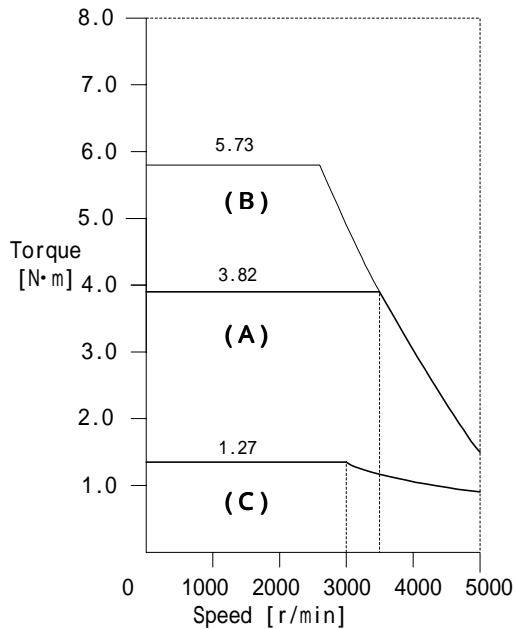

• GYC 751DC1 - SA ( 0.75 [kW] )

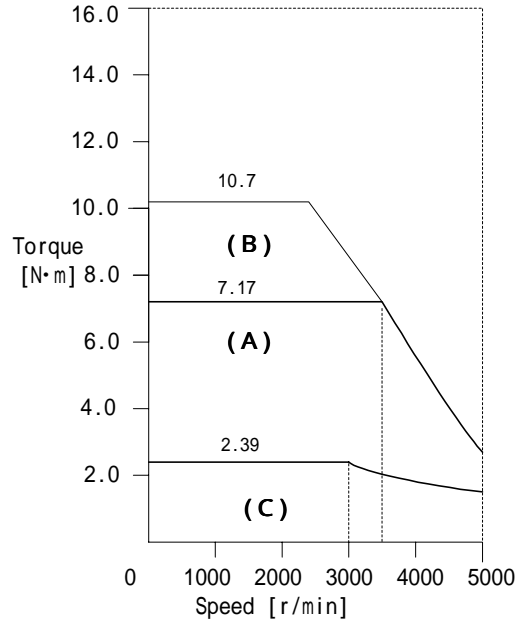

- (A) Acceleration/deceleration area 1
- (B) Acceleration/deceleration area 2
- (C) Continuous operation area

**(1) GYC motor, cubic type, for 200 [V] class input voltage of amplifier (cont'd)**

• GYC 1 0 2 DC 1 - SA ( 1 [kW] )

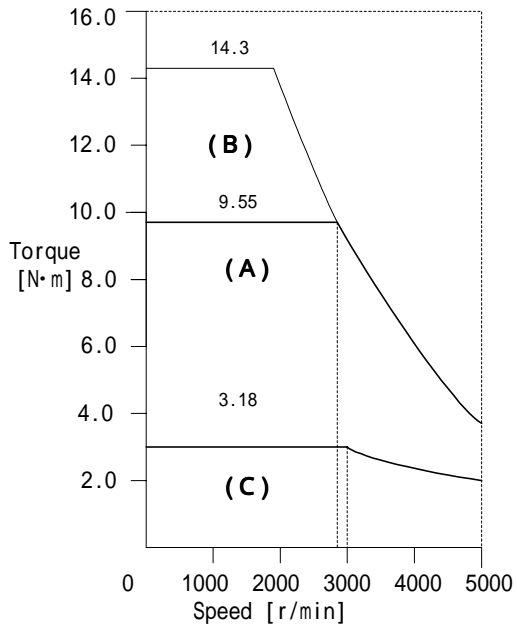

• GYC 1 5 2 DC 1 - SA ( 1 . 5 [kW] )

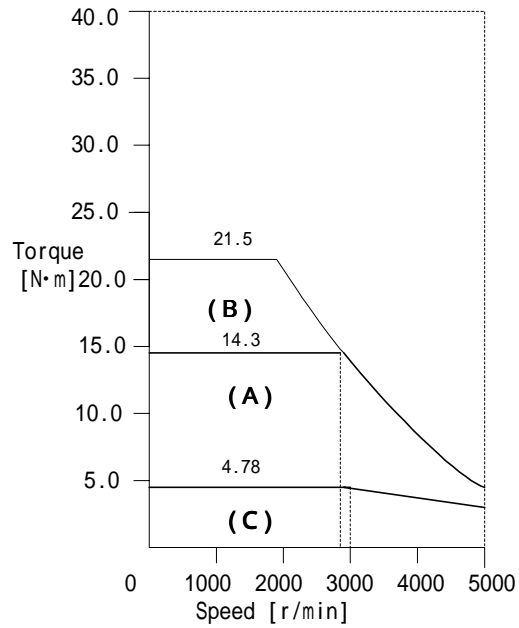

• GYC 2 0 2 DC 1 - SA ( 2 [kW] )

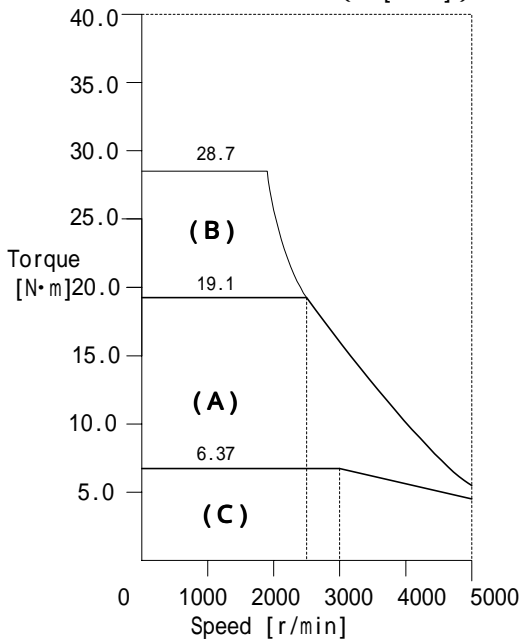

- (A) Acceleration/deceleration area 1
- (B) Acceleration/deceleration area 2
- (C) Continuous operation area

(2) GYS motor, slim type, for 200 [V] class input voltage of amplifier

• GYS 5 0 0 DC 1 - S 8 B ( 0 . 0 5 [ kW ] )    • GYS 1 0 1 DC 1 - S B ( 0 . 1 [ kW ] )

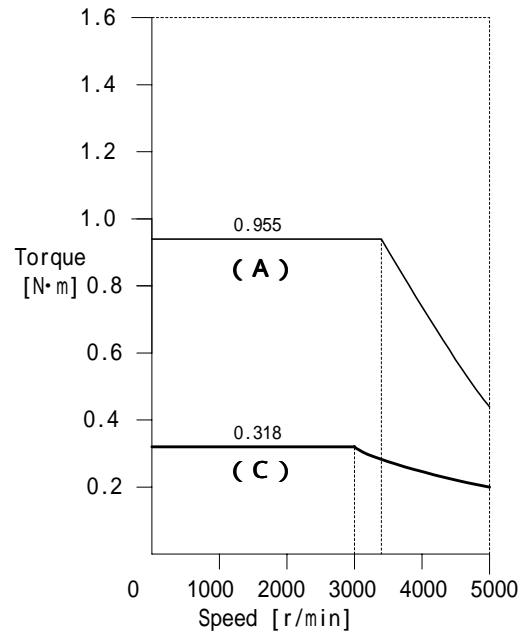
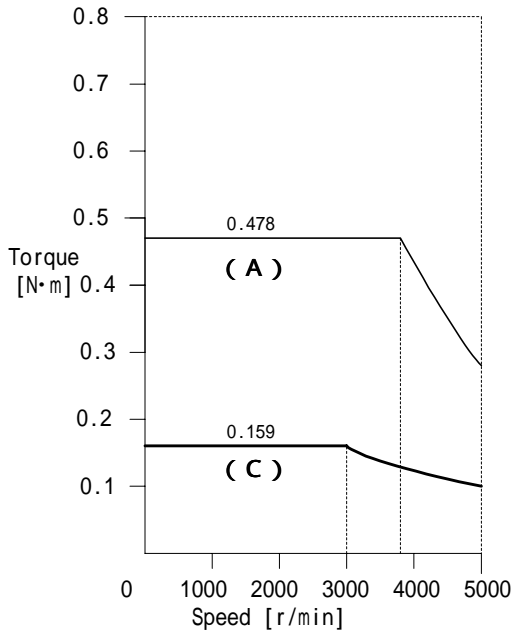

• GYS 2 0 1 DC 1 - S A ( 0 . 2 [ kW ] )

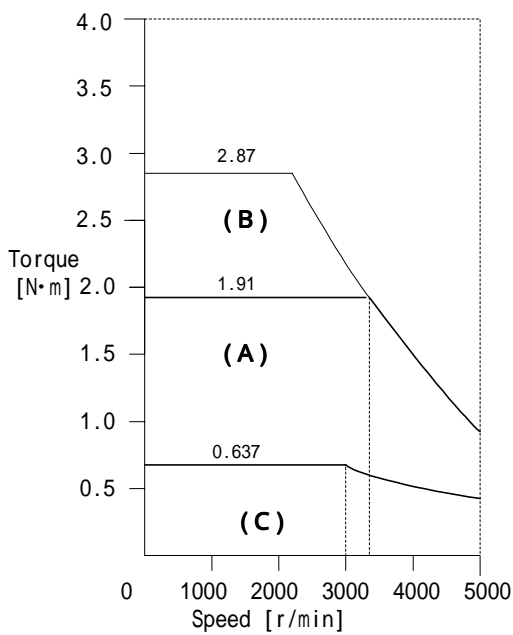

• GYS 4 0 1 DC 1 - S A ( 0 . 4 [ kW ] )

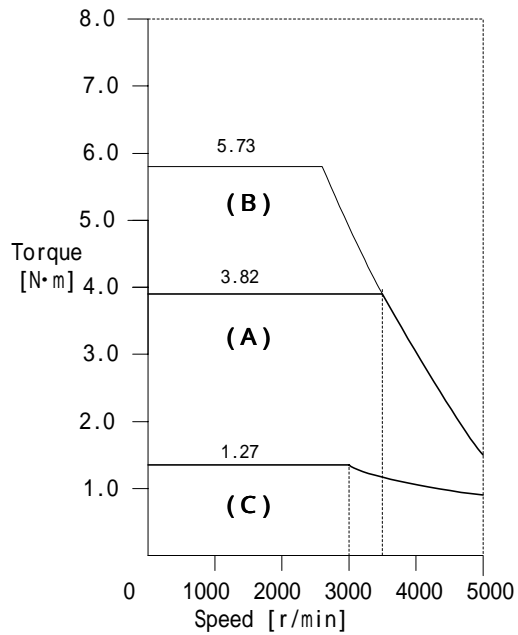

(2) GYS motor, slim type, for 200 [V] class input voltage of amplifier (cont'd)

• GYS 751DC1 - SA (0.75 [kW])

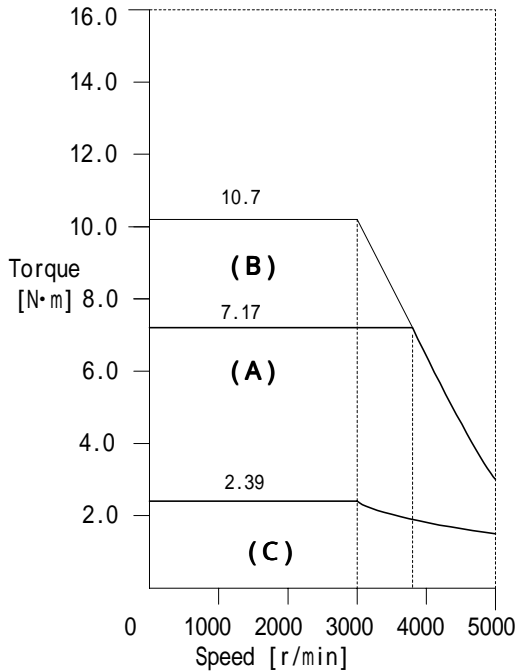

• GYS 102DC1 - SA (1 [kW])

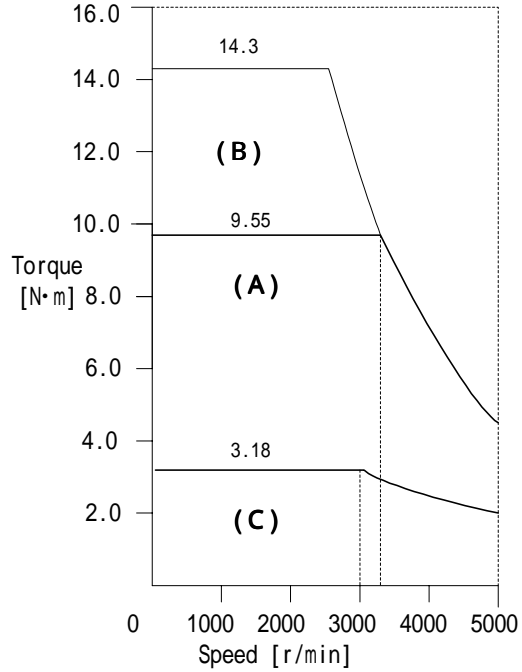

• GYS 152DC1 - SA (1.5 [kW])

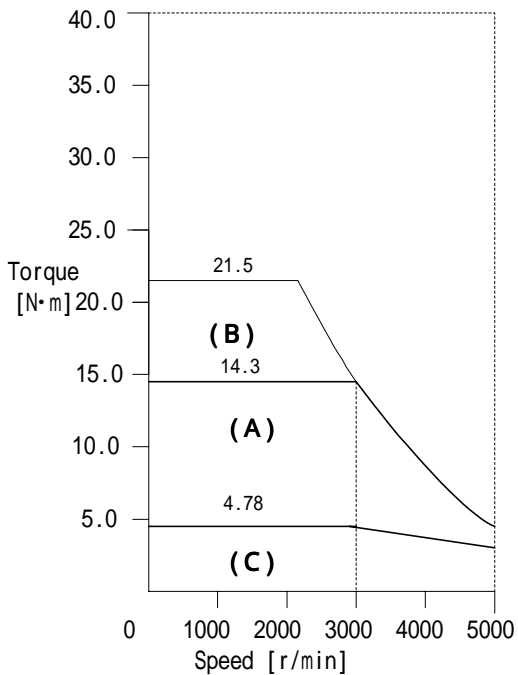

• GYS 202DC1 - SA (2 [kW])

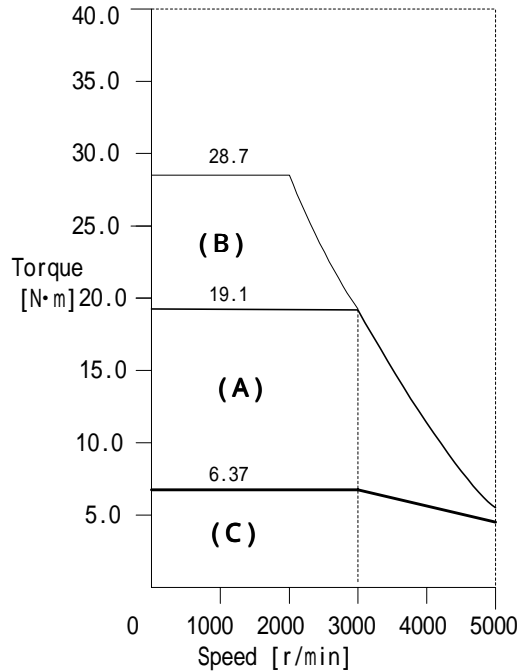

- (A) Acceleration/deceleration area 1
- (B) Acceleration/deceleration area 2
- (C) Continuous operation area

(2) GYS motor, slim type, for 200 [V] class input voltage of amplifier (cont'd)

• GYS 3 0 2 DC 1 - SA ( 3 [kW] )

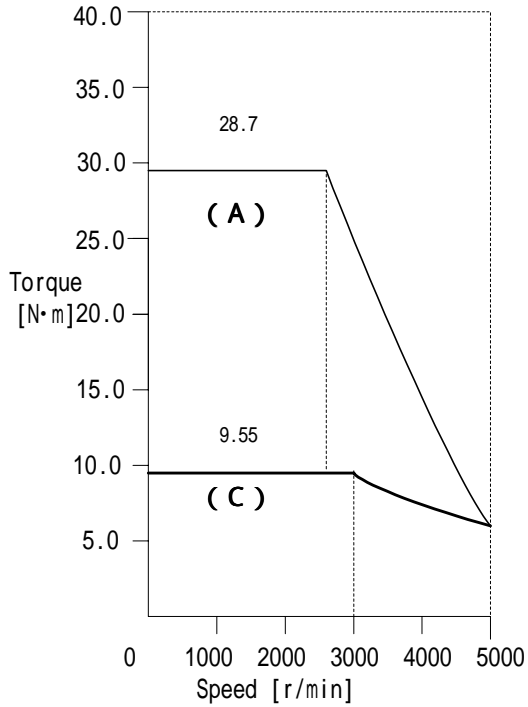

• GYS 4 0 2 DC 1 - SA ( 4 [kW] )

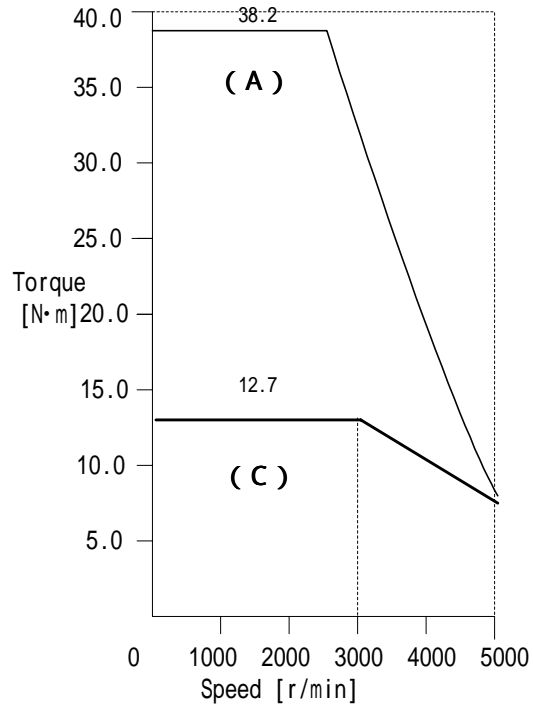

• GYS 5 0 2 DC 1 - SA ( 5 [kW] )

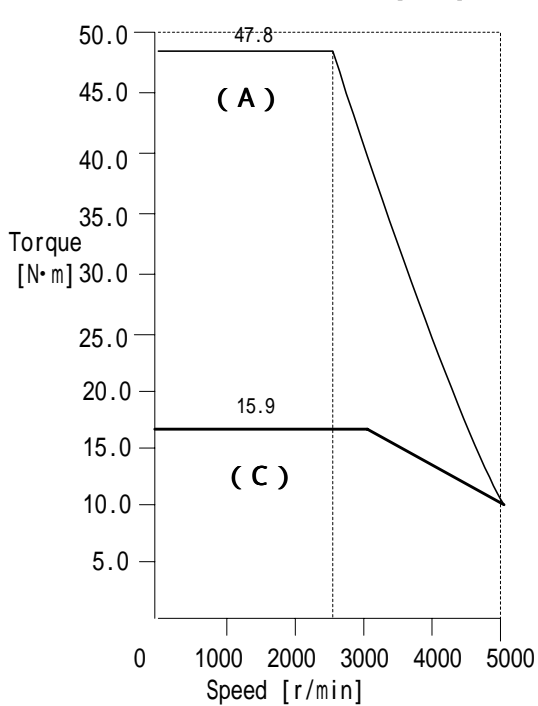

(3) GYS motor, slim type, for 100 [V] class input voltage of amplifier

• GYS 5 0 0 DC 1 - S 8 B ( 0 . 0 5 [ kW ] )

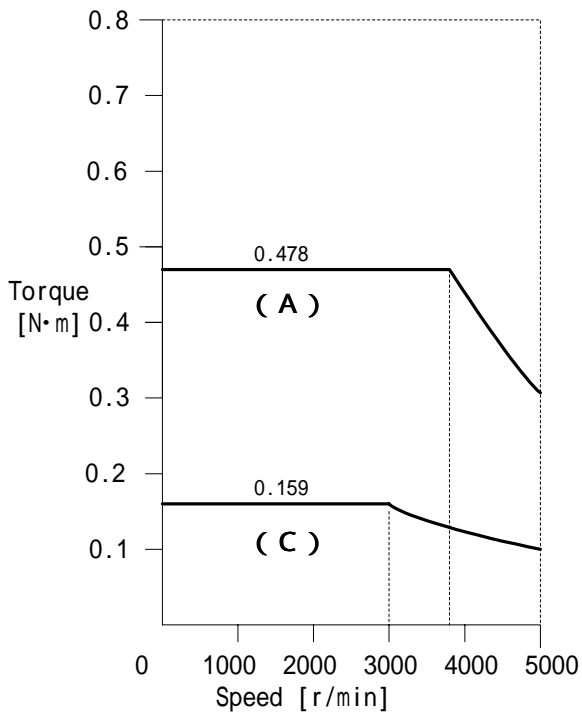

• GYS 1 0 1 DC 1 - S 6 B ( 0 . 1 [ kW ] )

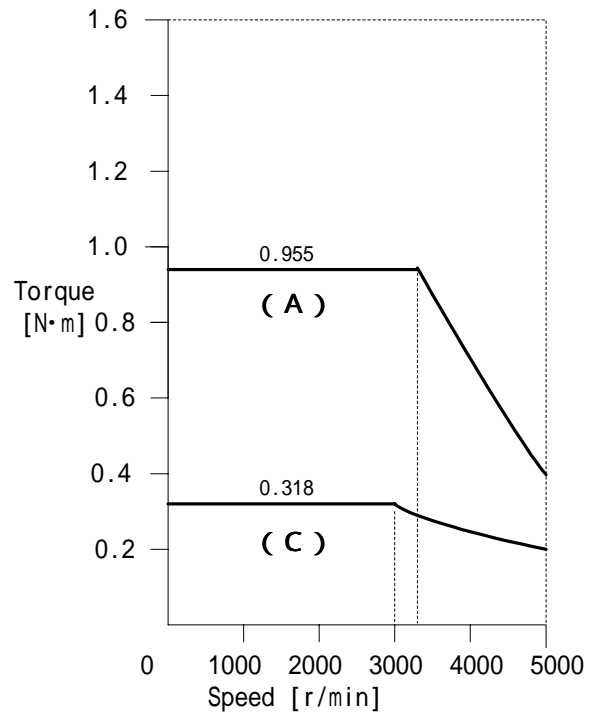

• GYS 2 0 1 DC 1 - S 6 B ( 0 . 2 [ kW ] )

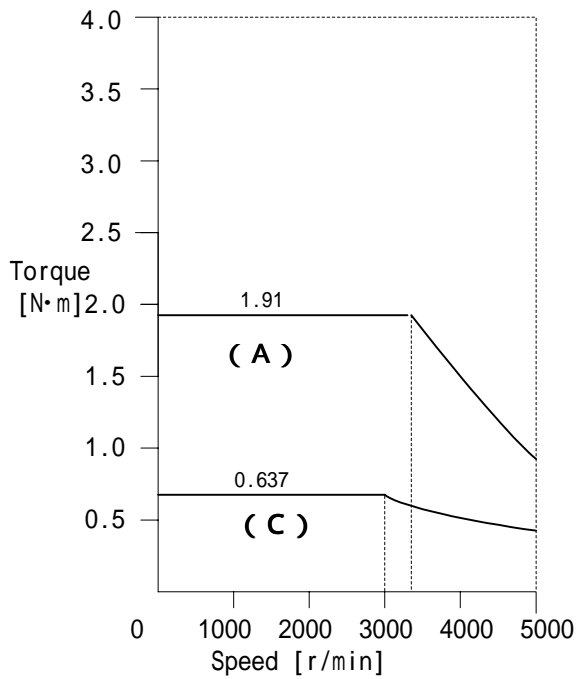

### 3. INSTALLATION

#### 3.1 Motor

##### (1) Installation environment

See 3.2 (1) (a)

##### (2) Type of construction (mounting)

Each motor allows the following methods of mounting.

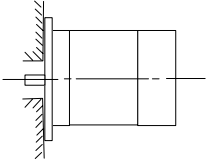
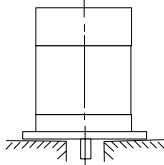
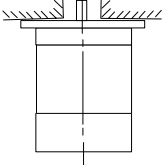
Flange-mounted		
IMB5	IMV1	IMV3
		

##### (3) No-oil or no-water-drop protection

In case oil or water drop splashes the motor, the motor should be protected with a suitable cover (example : "a" of figure), which will not close ventilation, and the motor should be mounted so that the terminal box, connector or connection cable should also be protected ("b" of figure). Do not allow oil or water drop to enter the inside of motor through the shaft extension.

For mechanical connection with an oil-lubricated reduction gear unit, its oil level should always be lower than in the motor bearing-housing ("c" of figure).

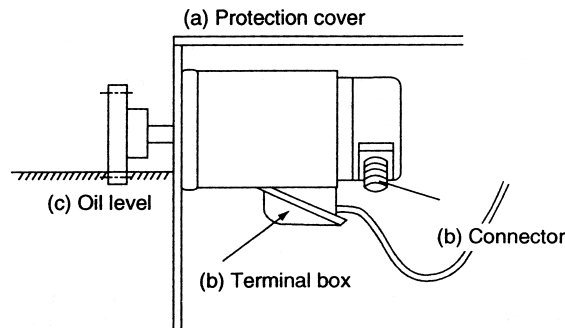

##### (4) Rotary encoder detector

- An encoder is used for detecting the position, speed of motor.
- The motor and encoder have been factory-aligned in the circumferential direction at the time of assembly. Therefore, the mounting position of the encoder should not be changed.

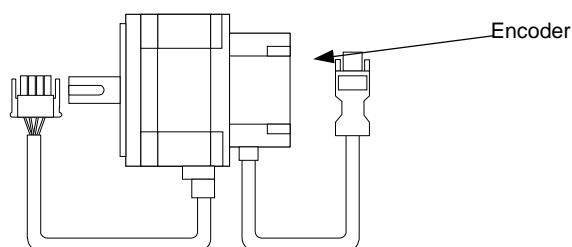



#### DO NOT DISASSEMBLE

Do not disassemble the motor unit. There is a risk that the machine can be broken due to abnormal operation.



#### CAUTION

Never give shocks to the encoder, motor and shaft extension, for example by hitting them with a hammer etc. In addition, be careful not to apply a load to the encoder during installation.

### (5) Mechanical coupling

(a) Motor with flexible coupling

(i) Provide a reference mark on the peripheral surface of the coupling.

(ii) Connect both halves of the coupling with a single-bolt, in order to allow them to rotate together.

(iii) Attach a dial gauge securely to one half of the coupling so that its feeler rests lightly on the other half.

(iv) Bring the reference mark to the top of the coupling and, then, measure dimension "g" with a thickness gauge and dimension "h" with a dial gauge.

(v) Turn the coupling and carry out the measurements described in (iv) above at 90 ° intervals until the reference mark appears at the top again.

(vi) Conduct adjustments so that the difference between the maximum and the minimum measurements is held to within 0.03mm. Be sure to bolt the motor and driven machine to the base prior to marking adjustments.

If a coupling is too small to allow a dial gauge to be attached to it, attach a stretch (rectangular steel bar) to one half of the coupling and measure the clearance value of the stretch and the surface of the other half of the coupling.

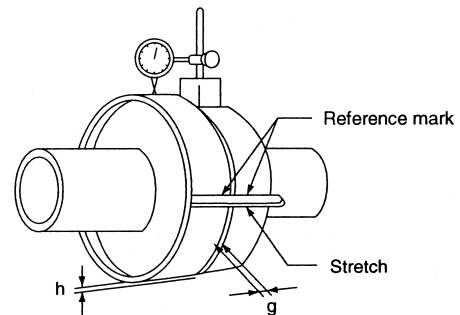

(b) Motor for external gear drive

If a gear drive is used, the shafts of both machines should be exactly parallel, to avoid subjecting the gear teeth to an excessive load at the contact points.

(c) Motor for timing belt connection

When using a timing belt, obtain necessary data from the belt supplier, and contact Fuji.

### (6) Power supply to motor



#### CAUTION

Do not connect commercial power supply to the motor terminals.

### (7) Dimensional tolerances

Tolerances of motor at the time of shipment from the factory are as follows.

The maximum and minimum values through one slow revolution of the shaft are then read on the indicator.

The difference between the readings will not exceed the values given in the following table.

(a) Shaft extension run-out

The probe of the indicator is attached to the shaft midway along its length.

(b) Concentricity of spigot and the shaft for flange-mounted motor

The indicator is fitted rigidly on the shaft extension.

(c) Perpendicularity of mounting face of flange to shaft for flange-mounted motor  
 The indicator is fitted rigidly on the shaft extension.

[unit : mm]

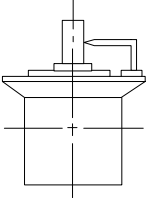
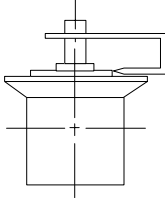
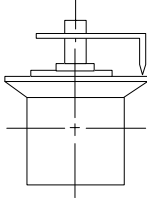
(a)	(b)	(c)
Flange-mounted	Flange-mounted	Flange-mounted
		
0.02	0.06	0.08

**(8) Mounting instruction of GYN and GRN type gear-head unit**

(a) Greasing to the shaft extension

Apply grease lightly to the output shaft extension of the motor, before mounting a GYC or GYS motor to gear-head unit.

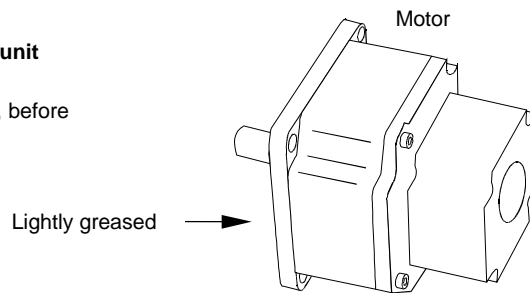

(b) Preparation for mounting

Remove the rubber cap from a deep point of the flange face of the gear-head unit.

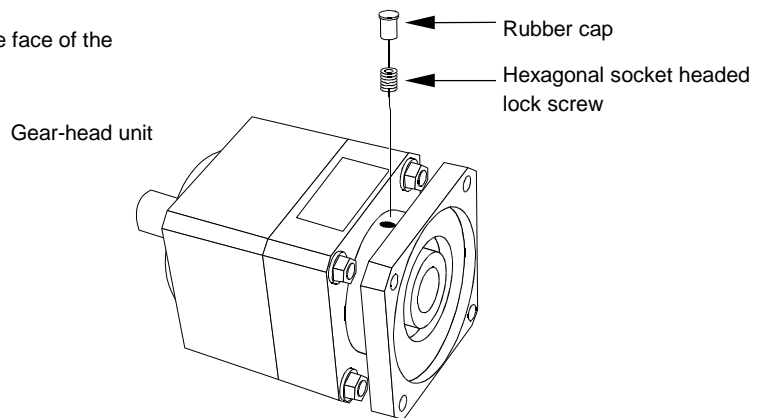

(c) Match the position of the key of the gear-head input-shaft with the position of the rubber cap hole.

Loosen the "hexagonal socket headed lock screw", which is located in the rubber cap hole. The hexagonal socket headed lock screw is positioned on the gear-head input-shaft.

(d) Mounting of motor

Insert the motor shaft extension with the key position matched with the gear-head input-shaft. Fasten the motor's flange face to the gear-head unit's flange face by the screws provided for the gear-head unit.

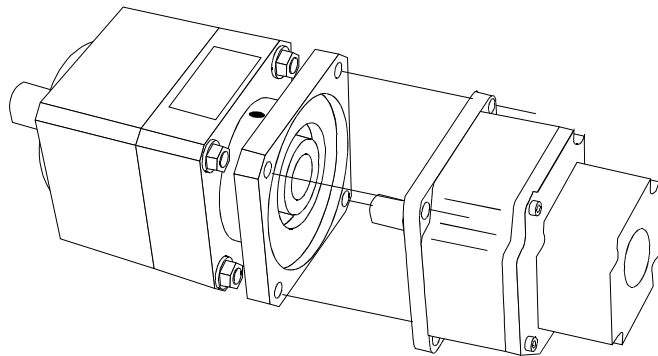

(e) Screw sizes

Motor type	GYS					GYC			
Gear-head type	GYN	SAG	GRN SAG		GYN	SAG	GYN	CAG	
	500	101	.20	.40	751		101	201	401

(i) Screws for fastening of flanges

Screw size [mm]	M4 x 12	M5 x 12	M4 x 12	M5 x 12
Screw q'ty	4			
Tightening torque [N·m]	1.8 ± 0.21	3.5 ± 0.42	1.8 ± 0.21	3.5 ± 0.42

(ii) Lock screws

Screw size [mm]	M4 x 4
Tightening torque [N·m]	1.8 ± 0.21

Tighten the "hexagonal socket headed lock screw" after fastening of flange faces.

Fit rubber cap in the original position.

**3.2 Amplifier**

**(1) Installation environment**

(a) Ambient climatic conditions

Ambient conditions		Amplifier	Motor
In transportation and storage (*1)	Temperature	- 20 to + 80	- 10 to + 70
	Humidity	90% RH max.	
	Air pressure	86 to 106 [kPa]	
Control rooms and equipment rooms (*1)	Temperature	- 10 to + 55	- 10 to + 40
	Humidity	90% RH max.	
	Air pressure	86 to 106 [kPa]	
Install location (*2)		For indoors	

(\*1) Free from condensation, no condensation, no formation of ice

(\*2) Site-altitude should be 1000 [m] and below.

(b) Avoid use under the following conditions.

- (i) Location near oil, steam or corrosive gas
- (ii) Location where strong electric or magnetic field exists
- (iii) Accommodation in the same panel together with high voltage (2 [kV] or higher) equipment
- (iv) Sharing of the same power supply with the equipment which generates large noise.
- (v) In vacuum
- (vi) In explosive atmosphere
- (vii) Under acceleration vibration

**(2) Mounting**

(a) Amplifier should be mounted upright so that character “FALDIC” on the front panel can be seen horizontal.

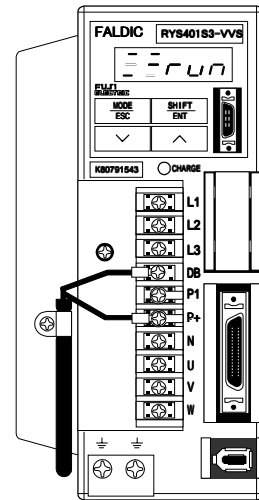

(b) Avoid overheating of the amplifier

When accommodating multiple amplifiers in the same panel, they should be installed side by side with the sufficient clearance distances below secured.

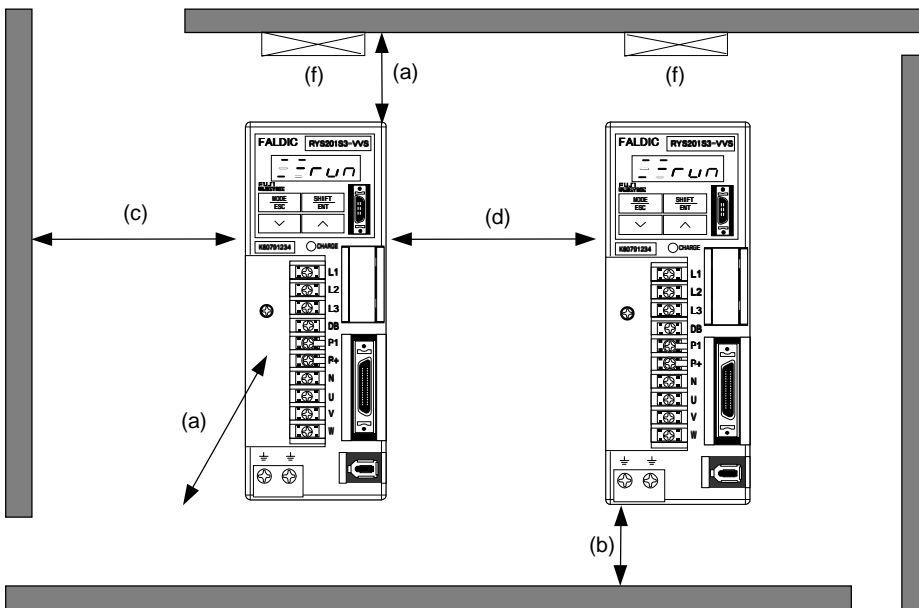

[unit : mm (min.)]

(a) Upper and front	(b) Lower	(c) Left and right	(d) Between amplifiers
50	40	10	(i) 5 (ii) If the clearance is 4.9 [mm] and below, operation duty type of amplifier is reduced to 80%ED (*), instead of continuous duty.

(f) Fan mounting

(\*) 80%ED : Cyclic duration factor operating duty is 80% : Intermittent periodic duty  
 The factor is defined as

$$\frac{N \text{ (operation under rated conditions)}}{N \text{ (operation under rated conditions)} + R \text{ (at rest and de-energized)}} \times 100 \text{ [\%]}$$

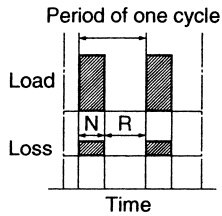

Intermittent periodic duty involve alternating operating and loading times and pauses during which a motor (or amplifier) is at a standstill (or de-energized).  
 The loading and standstill times of one cycle, which has a duration of 10 minutes, are so short that the steady-state temperature cannot be attained. The cycle duration factor is the ratio between the operating or loading time and cycle duration.

An ambient temperature of the amplifier must be kept at 55 °C maximum, at different points around the amplifier, at a distance of 50 [mm] maximum from the amplifier.

To keep the above mentioned ambient temperature of amplifier, the amplifier should be mounted in a forced-fan-ventilated panel or equivalent cooling conditions.

Avoid the excessive temperature rise due to heat losses by the regenerating braking resistor etc. in the panel.

(c) Forced-fan-ventilated panel

Provide an exhaust port and an air intake (suction) port in the panel, and mount a fan to the exhaust port to forced ventilate the internal air. Also, mount an air filter to the air intake port in order to maintain an environment better than IEC664 pollution degree 2 (\*) in the panel. For the air volume and the opening size of the air intake, refer to the following table.

Refer to technical document No. MHT221f (Engl.), chapter 2.2

(\*) Pollution degree 2: An environment in which only non-conductive pollution is generated, except for occasional occurrence of temporary conductivity due to condensation.

Amplifier output [kW]	0.05, 0.1	0.2	0.4	0.75	1
Air volume of forced-ventilation-fan [m <sup>3</sup> /min]	0.06	0.11	0.23	0.43	0.57
Opening size of air intake (suction air) [m <sup>2</sup> ]	0.0009	0.0019	0.0038	0.0071	0.0095

Amplifier output [kW]	1.5	2	3	4	5
Air volume of forced-ventilation-fan [m <sup>3</sup> /min]	0.85	1.14	1.7	2.27	2.84
Opening size of air intake (suction air) [m <sup>2</sup> ]	0.0142	0.0189	0.0284	0.0378	0.0473

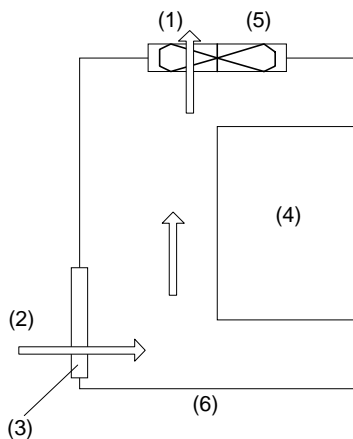

- (1) Exhaust air
- (2) Air intake, suction air
- (3) Air filter
- (4) Amplifier
- (5) Fan
- (6) Forced-fan-ventilated panel

Compliance with EC directives

- This product should be installed in the electrical cabinet.
- Servo driver is used under the "pollution degree 2" environment as specified in IEC664.

**(3) Peripheral equipment**

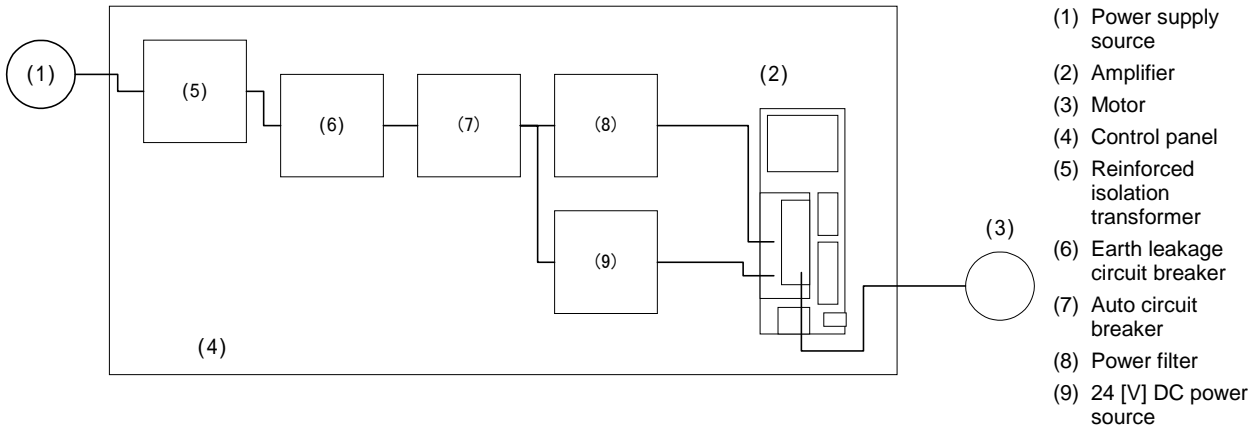

**(a) Power supply**

The amplifier is used under the "over voltage category II" environment as specified in IEC 664.

The power input unit uses a reinforced isolation transformer based on IEC/EN standards.

A 3-phase, star-connected transformer should be used without regard to single-phase and 3-phase models. The transformer should be grounded at the neutral point. The phase (line to earth) voltage must not exceed 120 [V].

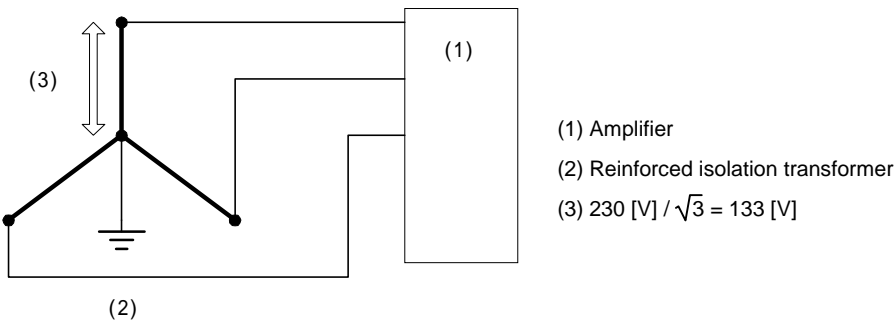

For the interface power source, use a 24 [V] DC power source with reinforced isolation type input and output.

**(b) Power filter**

Regarding the EMI terminal disturbance voltage, a power filter is required.

Input voltage class	[V]	100	200						
Amplifier output	[kW]	0.05 to 0.2	0.03 to 0.4	0.75 to 1	1.5	2	3	4	5
Power filter type	HF A-TM	3005		3010	3015	3020	3030	3040	3050
Current	[A]	5		10	15	20	30	40	50
Voltage		250[V] AC							
Leakage current		1.5 [mA] max. at 250 [V] AC, 60 [Hz]							

(c) Earthing (grounding)

To prevent electric shocks, the amplifier protection earth terminal and the control panel protection earth terminal should be connected to the ground.

When connecting earth cables to the protection earth terminal, do not tighten the cable terminals together.

The amplifier has two protection earth terminals. Do not connect copper cables directly to the amplifier terminals.

For the earth connection avoid direct contact between aluminum and copper.

Tin-plated cable lugs can be used if the plating does not contain zinc.

When tightening the screws take care not to damage the thread in the aluminum frame.

(d) Auto circuit breaker

Connect EN/IEC-approved auto circuit breaker between the power supply source and the power filter. See 11.2.

(e) Residual-current-operated protective device (RCD)

Where residual-current-operated protective device (RCD) is used for protection in case of direct or indirect contact, only RCD of type B is allowed on the supply side of this electric equipment (EE). Otherwise another protective measure should be applied such as separation of the EE from the environment by double or reinforced insulation or isolation of EE and supply system by a transformer.

(f) Conformity to EMC requirements

When the amplifier and motor have been finally installed with a driven machine and devices, they may not conform to the EMC requirements because the installation, wiring, etc. are different according to the final conditions. The driven machine and devices must therefore be measured for conformity to the EMC requirements under the final conditions with the amplifier and motor installed.

Compliance with UL standards

(a) Auto circuit breaker

For compliance with UL standards, connect UL-approved (with LISTED UL mark) auto circuit breaker between the power supply source and the power filter.

Input voltage class		[V]	100		200					
Amplifier output		[kW]	0.05, 0.1	0.2	0.03 to 0.2	0.4	0.75, 1	1.5	2, 3	4, 5
Amplifier type	RYS	S3-	6							
			500, 101	201	300 to 201	401	751, 102	152	202, 302	402, 502
Auto circuit breaker	type BU-ECA		3005	3010	3005	3010	3015	3020	3030	3050
	current	[A]	5	10	5	10	15	20	30	50

### 3.3 External dimensions [unit : mm]

#### (1) Motor, flange-mounted, for 200 [V] class input voltage of amplifier

(a) Basic design, GYC cubic type

GYC101 to 502DC1-SA type, 0.1 to 5 [kW]

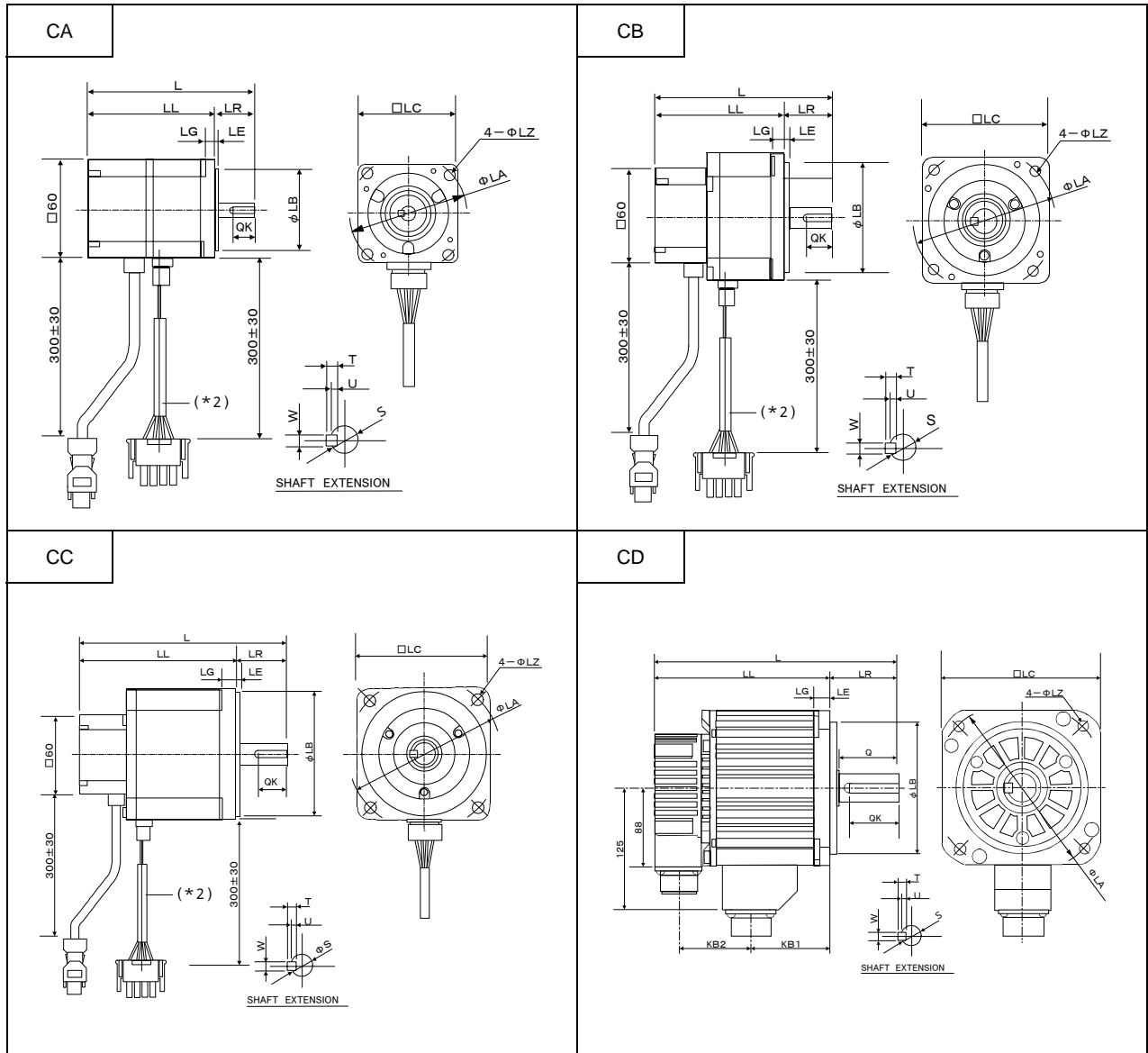

Type	Fig	Q	QK	QR	S	T	U	W	(*1)	L	LL	LR	LG	LE	LA	LB
GYC					(*3)											(*3)
101DC1-SA	CA	-	14	-	8h6	3	1.8	3	-	100	75	25	6	3	70	50h7
201DC1-SA	CB	-	16	-	14h6	5	3	5	-	112	82	30	8	3	90	70h7
401DC1-SA	CB	-	16	-	14h6	5	3	5	-	127	97	30	8	3	90	70h7
751DC1-SA	CC	-	22	-	16h6	5	3	5	-	156.5	116.5	40	10	3	115	95h7
102DC1-SA	CD	50	40	-	24h6	7	4	8	-	201.5	143.5	58	12	6	145	110h7
152DC1-SA	CD	50	40	-	24h6	7	4	8	-	216.5	158.5	58	12	6	145	110h7
202DC1-SA	CD	50	40	-	24h6	7	4	8	-	231.5	173.5	58	12	6	145	110h7
302DC1-SA																
402DC1-SA																
502DC1-SA																

(\*1) Screw hole (metric diameter x depth) of shaft extension (\*2) Insulating protection tube

(\*3) Shaft extension ( S ) and flanged spigot ( LB ) are machining finished with h6 or h7 fits.

(a) Basic design, GYC cubic type (cont'd)  
 GYC101 to 502DC1-SA type, 0.1 to 5 [kW]

	LC	L1	L2	L3	LZ	IE	IL	C	KB1	KB2	Mass [kg]
	60	-	-	-	5.5	-	-	-	-	-	0.75
	80	-	-	-	7	-	-	-	-	-	1.3
	80	-	-	-	7	-	-	-	-	-	1.9
	100	-	-	-	9	-	-	-	-	-	3.5
	130	-	-	-	9	-	-	-	65.5	59	5.5
	130	-	-	-	9	-	-	-	80.5	59	7
	130	-	-	-	9	-	-	-	95.5	59	8.2

(b) With providing brake, GYC cubic type  
GYC101 to 502DC1-SA-B type, 0.1 to 5 [kW]

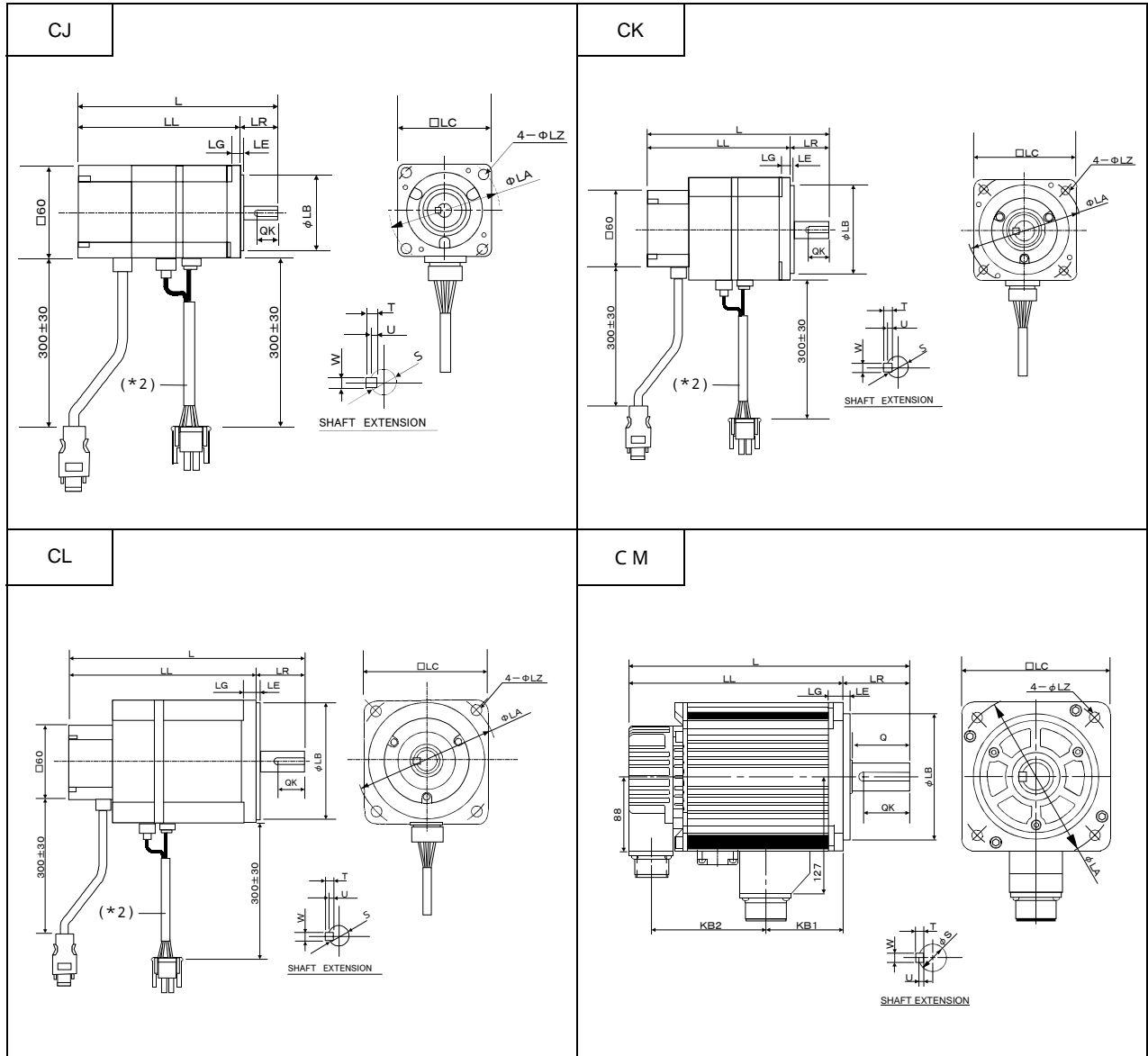

Type GYC	Fig	Q	QK	QR	S (*3)	T	U	W	(*1)	L	LL	LR	LG	LE	LA	LB (*3)
101DC1-SA-B	CJ	-	14	-	8h6	3	1.8	3	-	128	103	25	6	3	70	50h7
201DC1-SA-B	CK	-	16	-	14h6	5	3	5	-	143.5	113.5	30	8	3	90	70h7
401DC1-SA-B	CK	-	16	-	14h6	5	3	5	-	158.5	128.5	30	8	3	90	70h7
751DC1-SA-B	CL	-	22	-	16h6	5	3	5	-	189	149	40	10	3	115	95h7
102DC1-SA-B	CM	50	40	-	24h6	7	4	8	-	243.5	185.5	58	12	6	145	110h7
152DC1-SA-B	CM	50	40	-	24h6	7	4	8	-	258.5	200.5	58	12	6	145	110h7
202DC1-SA-B	CM	50	40	-	24h6	7	4	8	-	273.5	215.5	58	12	6	145	110h7
302DC1-SA-B																
402DC1-SA-B																
502DC1-SA-B																

(\*1) Screw hole (metric diameter x depth) of shaft extension (\*2) Insulating protection tube

(\*3) Shaft extension ( S ) and flanged spigot ( LB ) are machining finished with h6 or h7 fits.

(b) With providing brake, GYC cubic type (cont'd)  
 GYC101 to 502DC1-SA -B type, 0.1 to 5 [kW]

	LC	L1	L2	L3	LZ	IE	IL	C	KB1	KB2	Mass [kg]
	60	-	-	-	5.5	-	-	-	-	-	1.0
	80	-	-	-	7	-	-	-	-	-	1.9
	80	-	-	-	7	-	-	-	-	-	2.6
	100	-	-	-	9	-	-	-	-	-	4.3
	130	-	-	-	9	-	-	-	67.5	99	8.0
	130	-	-	-	9	-	-	-	82.5	99	9.8
	130	-	-	-	9	-	-	-	97.5	99	11.0

(c) With providing speed reduction gear unit, GYC cubic type, gear ratio 1/9  
 GYC101 to 202DC1-SA type, and gear head, 0.1 to 2 [kW]

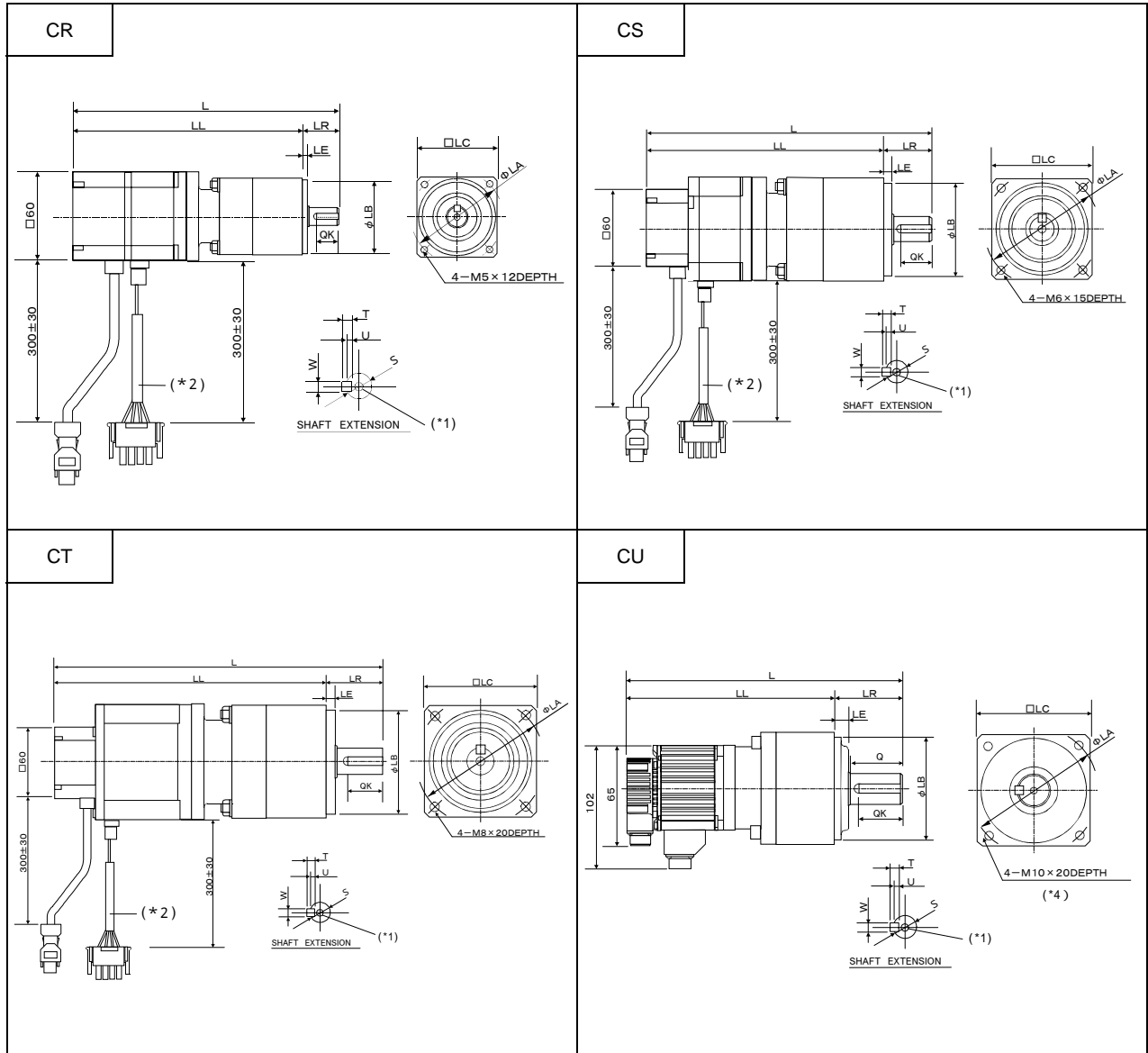

Type GYC	Fig	Q	QK	QR	S	T	U	W	(*1)	L	LL	LR	LG	LE	LA	LB
101DC1-SA	CR	-	15	-	12 <sup>+0</sup> <sub>-0.011</sub>	4	2.5	4	M4x8	178	153	25	-	4	60	50 <sup>+0</sup> <sub>-0.025</sub>
201DC1-SA	CS	-	23	-	19 <sup>+0</sup> <sub>-0.013</sub>	6	3.5	6	M5x13	218	181	37	-	6	90	70 <sup>+0</sup> <sub>-0.03</sub>
401DC1-SA	CS	-	23	-	19 <sup>+0</sup> <sub>-0.013</sub>	6	3.5	6	M5x13	233	196	37	-	6	90	70 <sup>+0</sup> <sub>-0.03</sub>
751DC1-SA	CT	-	30	-	24 <sup>+0</sup> <sub>-0.013</sub>	7	4	8	M6x15	282.5	233.5	49	-	8	115	90 <sup>+0</sup> <sub>-0.035</sub>
102DC1-SA	CU	55	45	-	32 <sup>+0</sup> <sub>-0.016</sub>	8	5	10	M6x15	362.5	298.5	64	-	8	135	110 <sup>+0</sup> <sub>-0.035</sub>
152DC1-SA	CU	55	45	-	32 <sup>+0</sup> <sub>-0.016</sub>	8	5	10	M6x15	377.5	313.5	64	-	8	135	110 <sup>+0</sup> <sub>-0.035</sub>
202DC1-SA	CV	55	45	-	32 <sup>+0</sup> <sub>-0.016</sub>	8	5	10		431.5	354.5	77	-	20	160	130 <sup>+0</sup> <sub>-0.04</sub>
-	-	-	-	-	-	-	-	-	-	-	-	-	-	-	-	-
-	-	-	-	-	-	-	-	-	-	-	-	-	-	-	-	-

(\*1) Screw hole (metric diameter x depth) of shaft extension      (\*2) Insulating protection tube

(\*4) For 152 type, 1.5 [kW] : 4 - M12 x 24 DEPTH

(c) With providing speed reduction gear unit, GYC cubic type, gear ratio 1/9 (cont'd)  
 GYC101 to 202DC1-SA type, and gear head, 0.1 to 2 [kW]

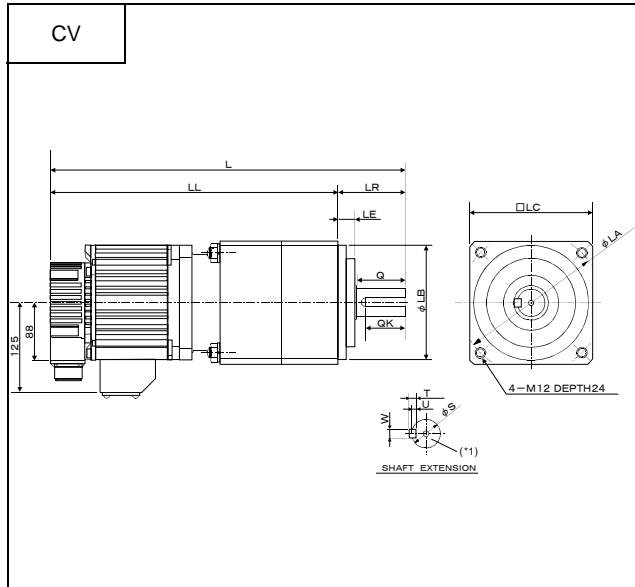

	LC	L1	L2	L3	LZ	IE	IL	C	KB1	KB2	Mass [kg]
	52	-	-	-	-	-	-	-	-	-	1.47
	78	-	-	-	-	-	-	-	-	-	3.4
	78	-	-	-	-	-	-	-	-	-	4.0
	98	-	-	-	-	-	-	-	-	-	7.3
	120	-	-	-	-	-	-	-	-	-	13.3
	120	-	-	-	-	-	-	-	-	-	14.8
	140	-	-	-	-	-	-	-	-	-	20.4

(d) With providing speed reduction gear unit, GYC cubic type, gear ratio 1/25 (for 101 to 751 types) or 1/15 (for 102 to 202 types) GYC101 to 202DC1-SA type, and gear head, 0.1 to 2 [kW]

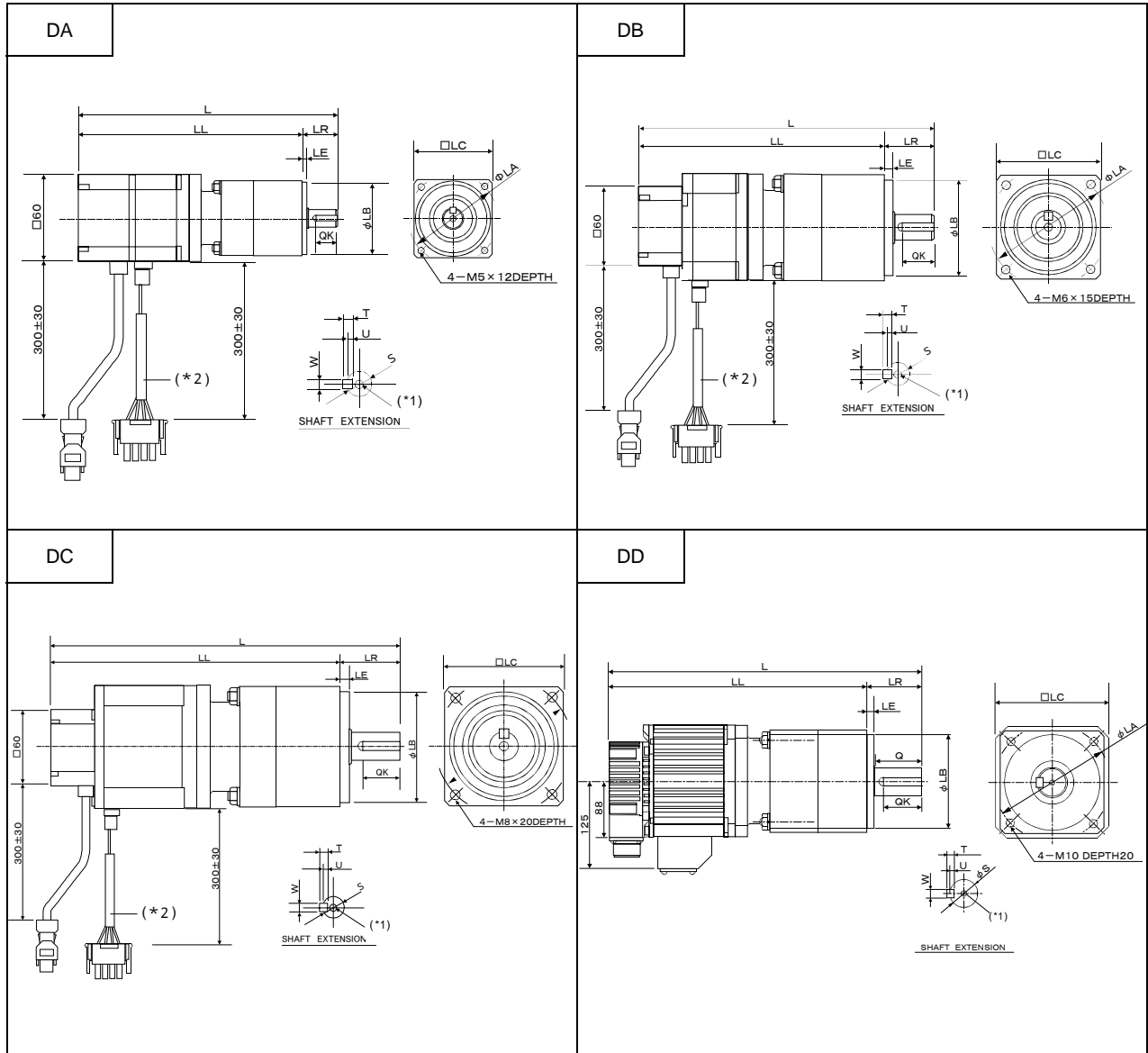

Type GYC	Fig	Q	QK	QR	S	T	U	W	(*1)	L	LL	LR	LG	LE	LA	LB
101DC1-SA	DA	-	15	-	$12^{+0}_{-0.011}$	4	2.5	4	M4x8	178	153	25	-	4	60	$50^{+0}_{-0.025}$
201DC1-SA	DB	-	23	-	$19^{+0}_{-0.013}$	6	3.5	6	M5x13	218	181	37	-	6	90	$70^{+0}_{-0.03}$
401DC1-SA	DB	-	23	-	$19^{+0}_{-0.013}$	6	3.5	6	M5x13	233	196	37	-	6	90	$70^{+0}_{-0.03}$
751DC1-SA	DC	-	30	-	$24^{+0}_{-0.013}$	7	4	8	M6x15	282.5	233.5	49	-	8	115	$90^{+0}_{-0.035}$
102DC1-SA	DD	55	45	-	$32^{+0}_{-0.016}$	8	5	10		362.5	298.5	64	-	8	135	$110^{+0}_{-0.035}$
152DC1-SA	DD	55	45	-	$32^{+0}_{-0.016}$	8	5	10		377.5	313.5	64	-	8	135	$110^{+0}_{-0.035}$
202DC1-SA	DE	55	45	-	$32^{+0}_{-0.016}$	8	5	10		431.5	354.5	77	-	20	160	$130^{+0}_{-0.04}$

(\*1) Screw hole (metric diameter x depth) of shaft extension (\*2) Insulating protection tube

(d) With providing speed reduction gear unit, GYC cubic type, gear ratio 1/25 (for 101 to 751 types) or 1/15 (for 102 to 202 types), (cont'd)  
 GYC101 to 202DC1-SA type, and gear head, 0.1 to 2 [kW]

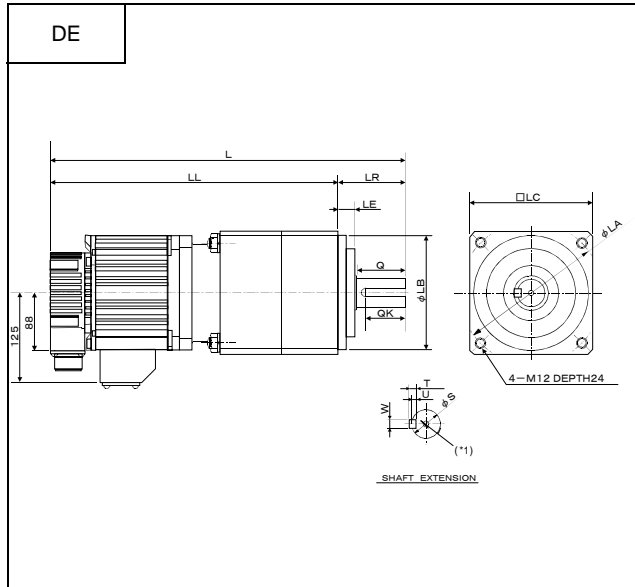

	LC	L1	L2	L3	LZ	IE	IL	C	KB1	KB2	Mass [kg]
	52	-	-	-	-	-	-	-	-	-	1.47
	78	-	-	-	-	-	-	-	-	-	3.4
	78	-	-	-	-	-	-	-	-	-	4.0
	98	-	-	-	-	-	-	-	-	-	7.3
	120	-	-	-	-	-	-	-	-	-	13.3
	120	-	-	-	-	-	-	-	-	-	14.8
	140	-	-	-	-	-	-	-	-	-	20.4

(e) Gear-head unit for GYC cubic type motor, gear ratio 1/9  
 GYN101 to 202CAG - G09 type, 0.1 to 2 [kW]

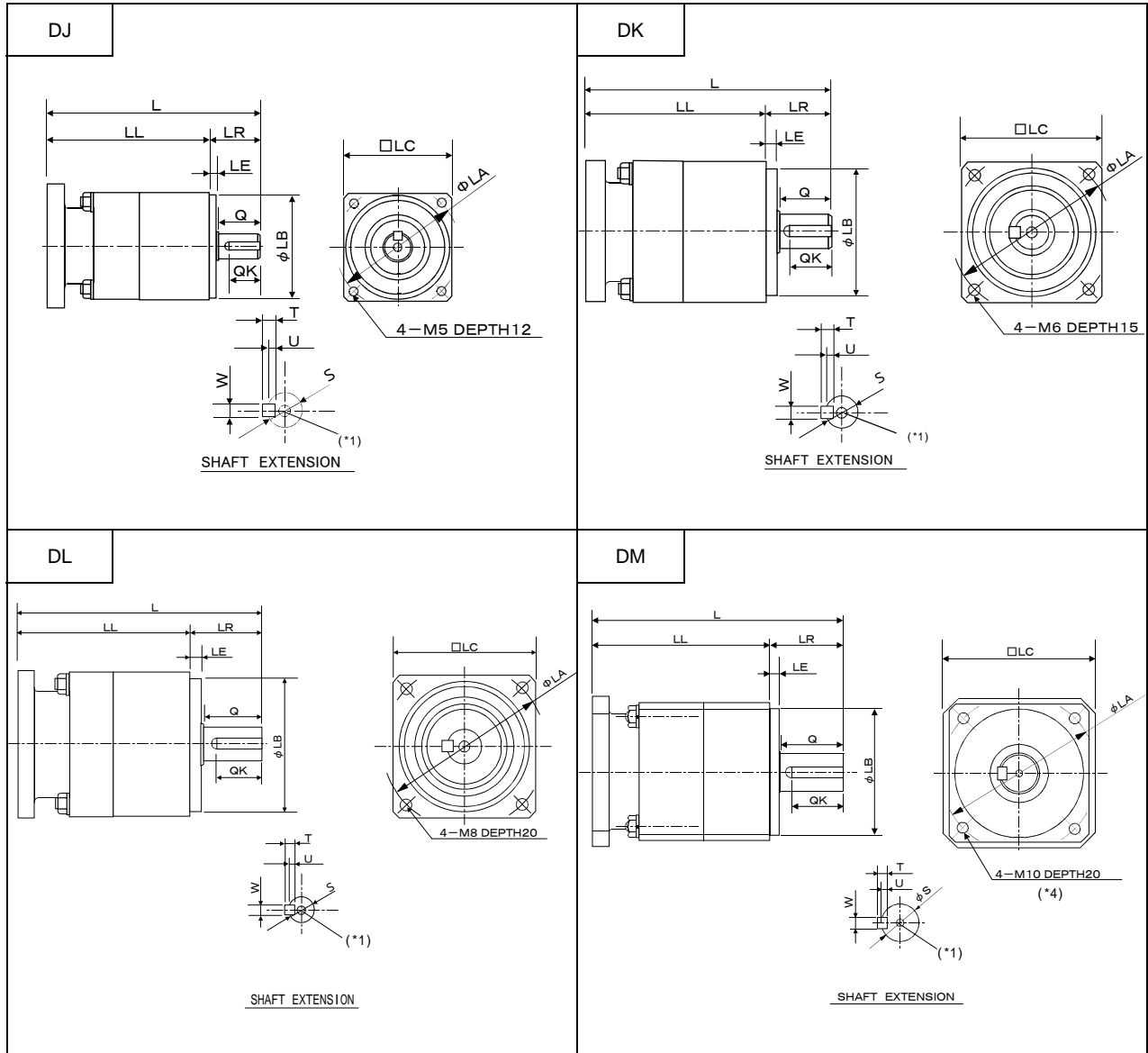

Type	Fig	Q	QK	QR	S	T	U	W	(*1)	L	LL	LR	LG	LE	LA	LB	LC	Mass [kg]
GYN G09																		
101CAG-	DJ	20	15	-	12 <sup>+0</sup> <sub>-0.011</sub>	4	2.5	4	M4x8	103	78	25	-	4	60	50 <sup>+0</sup> <sub>-0.025</sub>	52	0.72
201CAG-	DK	30	23	-	19 <sup>+0</sup> <sub>-0.013</sub>	6	3.5	6	M5x13	136	99	37	-	6	90	70 <sup>+0</sup> <sub>-0.03</sub>	78	2.1
401CAG-	DK	30	23	-	19 <sup>+0</sup> <sub>-0.013</sub>	6	3.5	6	M5x13	136	99	37	-	6	90	70 <sup>+0</sup> <sub>-0.03</sub>	78	2.1
751CAG-	DL	40	30	-	24 <sup>+0</sup> <sub>-0.013</sub>	7	4	8	M6x15	166	117	49	-	8	115	90 <sup>+0</sup> <sub>-0.035</sub>	98	3.8
102CAG-	DM	55	45	-	32 <sup>+0</sup> <sub>-0.016</sub>	8	5	10	M6x15	219	155	64	-	8	135	110 <sup>+0</sup> <sub>-0.035</sub>	120	7.8
152CAG-	DM	55	45	-	32 <sup>+0</sup> <sub>-0.016</sub>	8	5	10	M6x15	219	155	64	-	8	135	110 <sup>+0</sup> <sub>-0.035</sub>	120	7.8
202CAG-	DN	55	45	-	32 <sup>+0</sup> <sub>-0.016</sub>	8	5	10		258	181	77	-	20	160	130 <sup>+0</sup> <sub>-0.04</sub>	140	12.2
-	-	-	-	-	-	-	-	-	-	-	-	-	-	-	-	-	-	-
-	-	-	-	-	-	-	-	-	-	-	-	-	-	-	-	-	-	-

(\*1) Screw hole (metric diameter x depth) of shaft extension

(\*4) For 152 type, 1.5 [kW] : 4 - M12 x 24 DEPTH

(e) Gear-head unit for GYC cubic type motor, gear ratio 1/9 (cont'd)  
GYN101 to 202CAG-G09 type, 0.1 to 2 [kW]

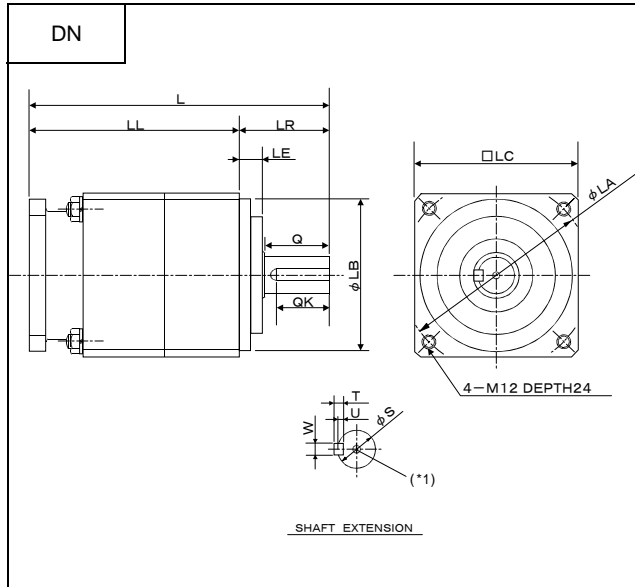

(f) Gear-head unit for GYC cubic type motor, gear ratio 1/25 (for 101 to 751 types) or 1/15 (for 102 to 202 types)  
 GYN101 to 202CAG - G25 or G15, 0.1 to 2 [kW]

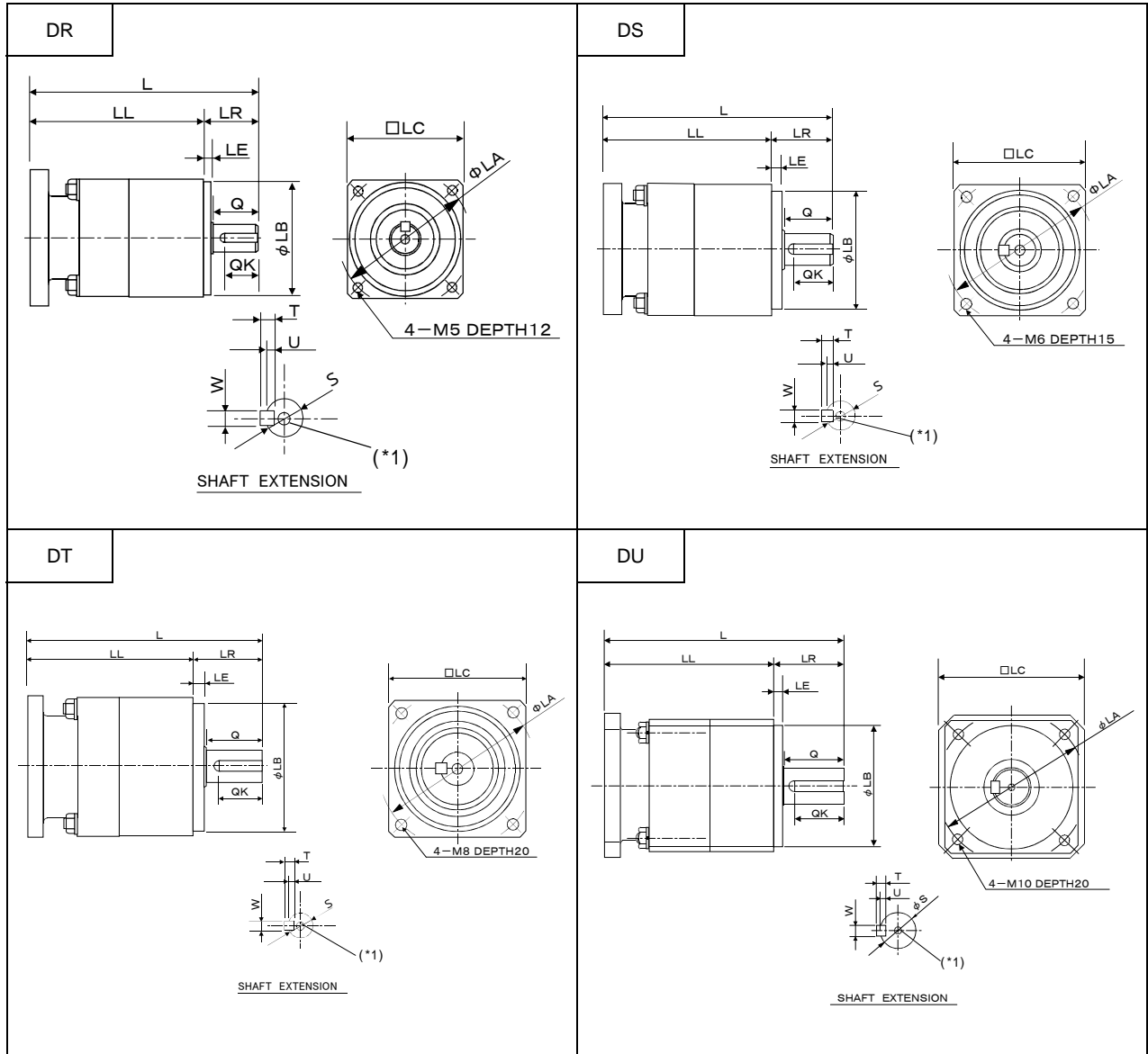

Type GYN	Fig	Q	QK	QR	S	T	U	W	(*1)	L	LL	LR	LG	LE	LA	LB	LC	Mass [kg]
101CAG-G25	DR	20	15	-	12 <sup>+0</sup> <sub>-0.011</sub>	4	2.5	4	M4x8	103	78	25	-	4	60	50 <sup>+0</sup> <sub>-0.025</sub>	52	0.72
201CAG-G25	DS	30	23	-	19 <sup>+0</sup> <sub>-0.013</sub>	6	3.5	6	M5x13	136	99	37	-	6	90	70 <sup>+0</sup> <sub>-0.03</sub>	78	2.1
401CAG-G25	DS	30	23	-	19 <sup>+0</sup> <sub>-0.013</sub>	6	3.5	6	M5x13	136	99	37	-	6	90	70 <sup>+0</sup> <sub>-0.03</sub>	78	2.1
751CAG-G25	DT	40	30	-	24 <sup>+0</sup> <sub>-0.013</sub>	7	4	8	M6x15	166	117	49	-	8	115	90 <sup>+0</sup> <sub>-0.035</sub>	98	3.8
102CAG-G15	DU	55	45	-	32 <sup>+0</sup> <sub>-0.016</sub>	8	5	10	-	219	155	64	-	8	135	110 <sup>+0</sup> <sub>-0.035</sub>	120	7.8
152CAG-G15	DU	55	45	-	32 <sup>+0</sup> <sub>-0.016</sub>	8	5	10	-	219	155	64	-	8	135	110 <sup>+0</sup> <sub>-0.035</sub>	120	7.8
202CAG-G15	DV	55	45	-	32 <sup>+0</sup> <sub>-0.016</sub>	8	5	10	-	258	181	77	-	20	160	130 <sup>+0</sup> <sub>-0.04</sub>	140	12.2
-	-	-	-	-	-	-	-	-	-	-	-	-	-	-	-	-	-	-
-	-	-	-	-	-	-	-	-	-	-	-	-	-	-	-	-	-	-
-	-	-	-	-	-	-	-	-	-	-	-	-	-	-	-	-	-	-

(\*1) Screw hole (metric diameter x depth) of shaft extension

(f) Gear-head unit for GYC cubic type motor, gear ratio 1/25 (for 101 to 751 types) or 1/15 (for 102 to 202 types) (cont'd)  
 GYN101 to 202CAG-G25 or G15, 0.1 to 2 [kW]

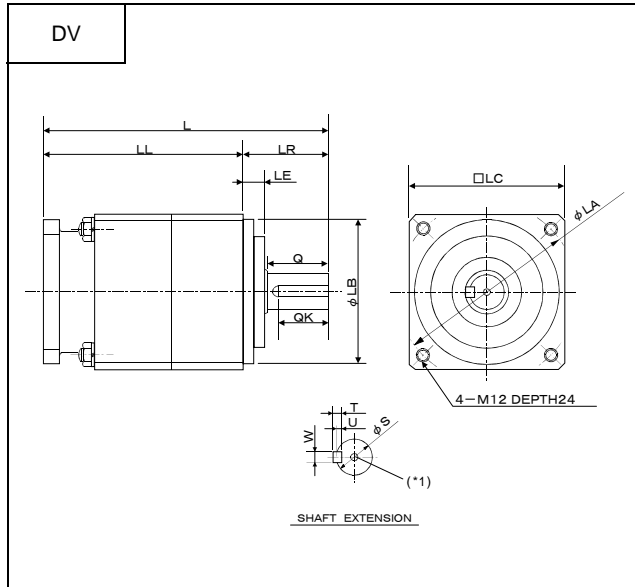

(g) Basic design, GYS slim type  
 GYS300 to 502DC1-S8B, SB or SA type, 0.03 to 5 [kW]

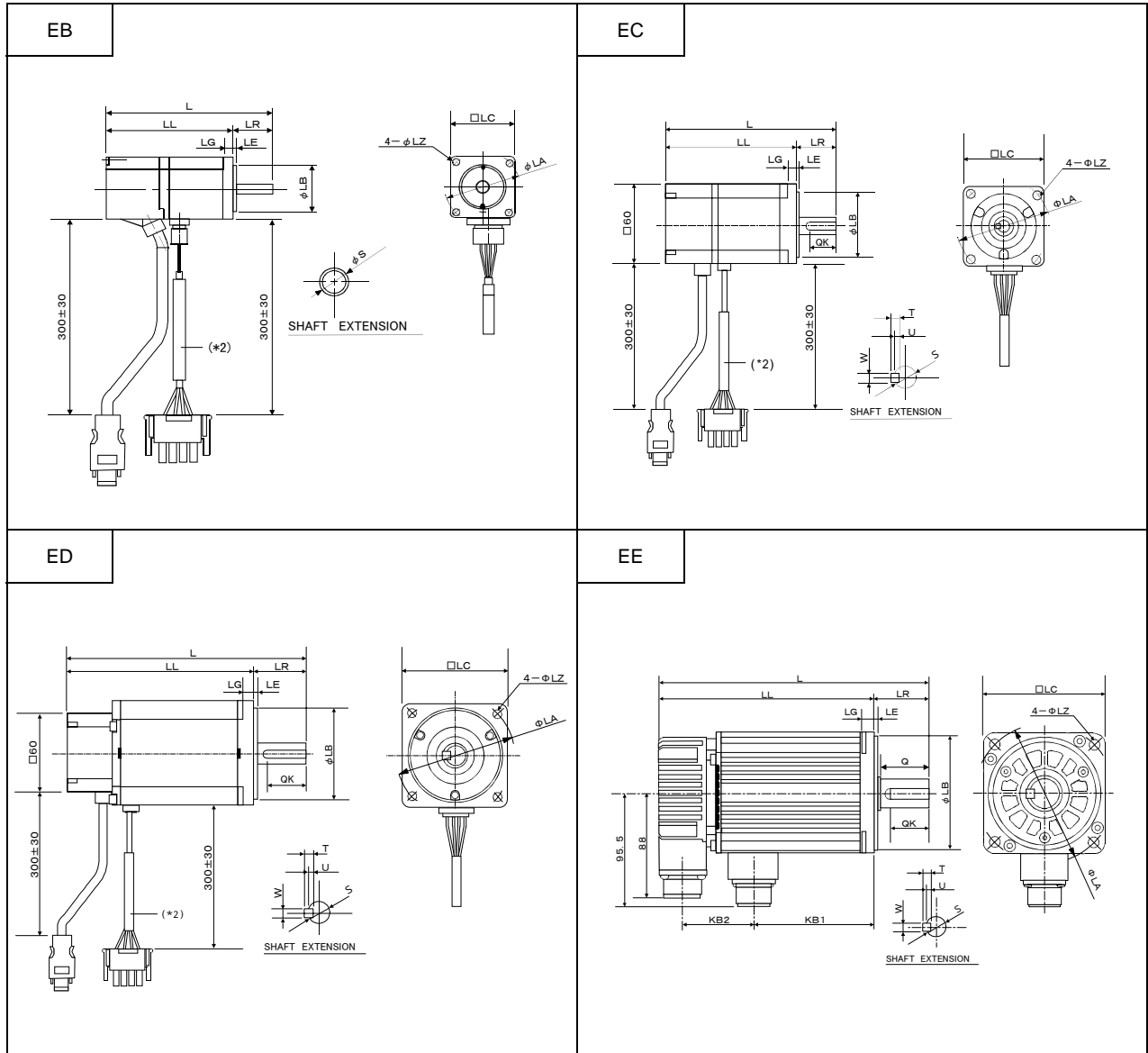

Type	Fig	Q	QK	QR	S	T	U	W	(*1)	L	LL	LR	LG	LE	LA	LB
GYS					(*3)											(*3)
300DC1-S8B																
500DC1-S8B	EB	-	-	-	6h6	-	-	-	-	103	78	25	5	2.5	46	30h7
101DC1-SB	EB	-	-	-	8h6	-	-	-	-	121	96	25	5	2.5	46	30h7
201DC1-SA	EC	-	20	-	14h6	5	3	5	-	126.5	96.5	30	6	3	70	50h7
401DC1-SA	EC	-	20	-	14h6	5	3	5	-	154.5	124.5	30	6	3	70	50h7
751DC1-SA	ED	-	30	-	16h6	5	3	5	-	180	140	40	8	3	90	70h7
102DC1-SA	EE	40	32	-	24h6	7	4	8	-	198	153	45	10	3	115	95h7
152DC1-SA	EE	40	32	-	24h6	7	4	8	-	220.5	175.5	45	10	3	115	95h7
202DC1-SA	EE	40	32	-	24h6	7	4	8	-	243	198	45	10	3	115	95h7
302DC1-SA	EF	55	46	-	28h6	7	4	8	-	266.5	203.5	63	12	6	145	110h7
402DC1-SA	EF	55	46	-	28h6	7	4	8	-	296.5	233.5	63	12	6	145	110h7
502DC1-SA	EF	55	46	-	28h6	7	4	8	-	326.5	263.5	63	12	6	145	110h7

(\*1) Screw hole (metric diameter x depth) of shaft extension (\*2) Insulating protection tube  
 (\*3) Shaft extension ( S ) and flanged spigot ( LB ) are machining finished with h6 or h7 fits.

(g) Basic design, GYS slim type (cont'd)  
 GYS300 to 502DC1-S8B, SB or SA type, 0.03 to 5 [kW]

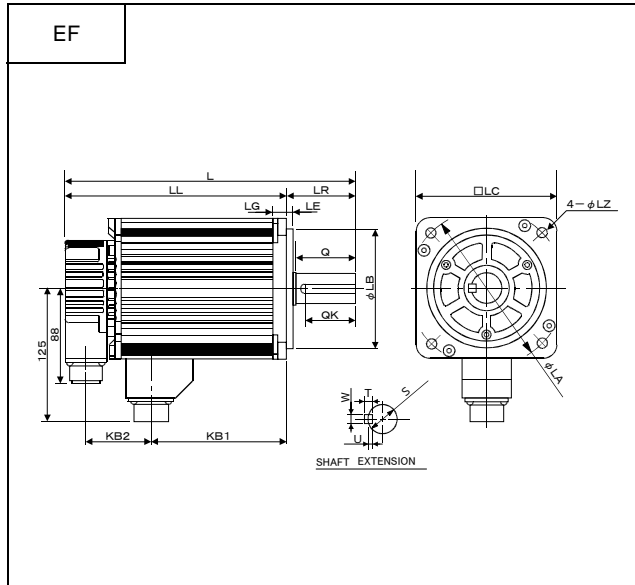

	LC	L1	L2	L3	LZ	IE	IL	C	KB1	KB2	Mass [kg]
-----	40	-	-	-	4.3	-	-	-	-	-	0.45
-----	40	-	-	-	4.3	-	-	-	-	-	0.55
-----	60	-	-	-	5.5	-	-	-	-	-	1.2
-----	60	-	-	-	5.5	-	-	-	-	-	1.8
-----	80	-	-	-	7	-	-	-	-	-	3.4
-----	100	-	-	-	9	-	-	-	77	57	4.4
-----	100	-	-	-	9	-	-	-	99.5	57	5.2
-----	100	-	-	-	9	-	-	-	122	57	6.3
-----	130	-	-	-	9	-	-	-	122.5	59	11.0
-----	130	-	-	-	9	-	-	-	155.5	59	13.5
-----	130	-	-	-	9	-	-	-	185.5	59	16.0

(h) With providing brake, GYS slim type  
 GYS300 to 502DC1-S8B, SB or SA-B type, 0.03 to 5 [kW]

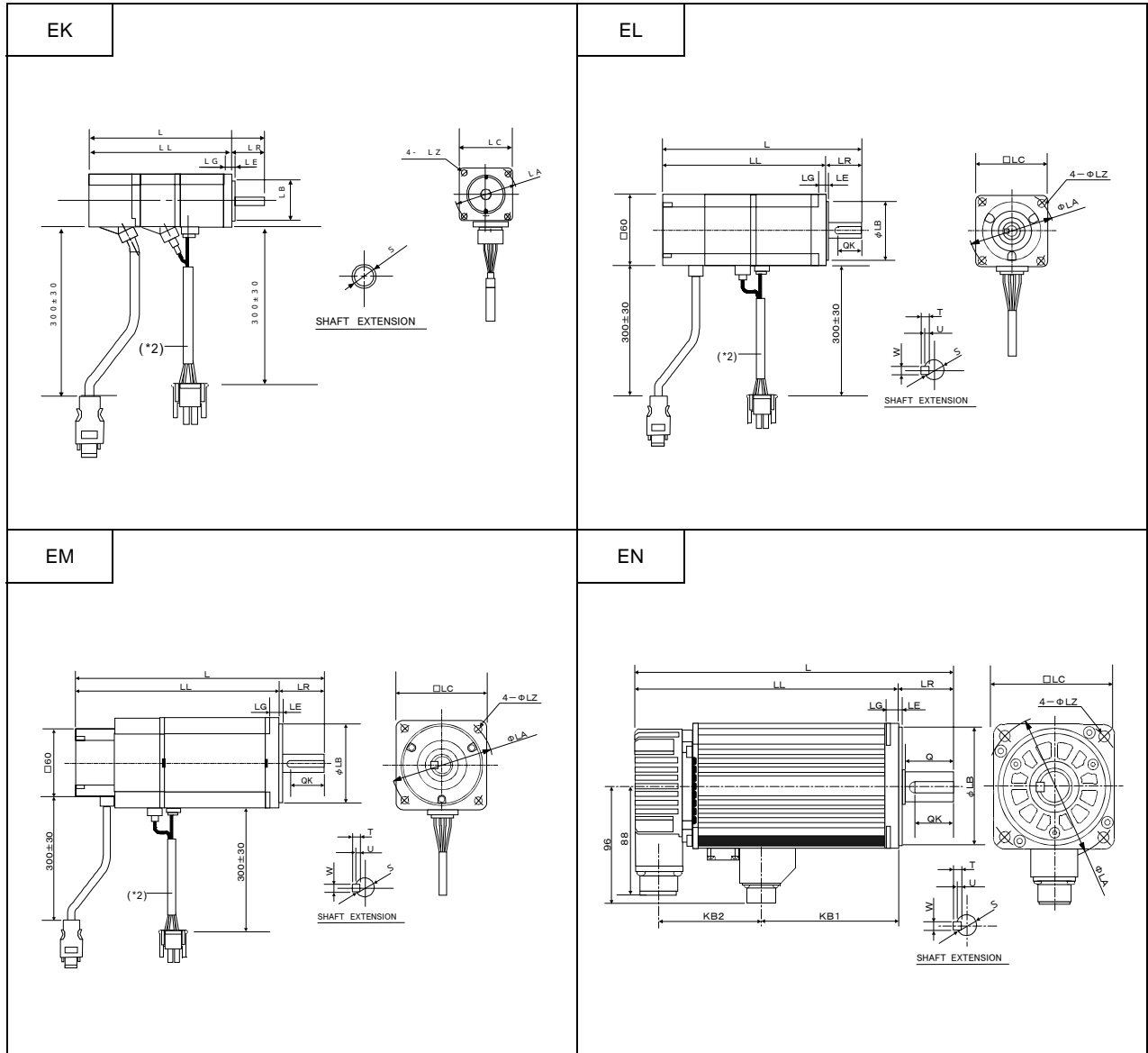

Type GYS	Fig	Q	QK	QR	S (*3)	T	U	W	(*1)	L	LL	LR	LG	LE	LA	LB (*3)
300DC1-S8-B		-	-	-	6h6	-	-	-	-	140	115	25	2.5	2.5	46	30h7
500DC1-S8-B	EK	-	-	-	6h6	-	-	-	-	140	115	25	2.5	2.5	46	30h7
101DC1-SB-B	EK	-	-	-	8h6	-	-	-	-	158	133	25	2.5	2.5	46	30h7
201DC1-SA-B	EL	-	20	-	14h6	5	3	5	-	165	135	30	6	3	70	50h7
401DC1-SA-B	EL	-	20	-	14h6	5	3	5	-	193	163	30	6	3	70	50h7
751DC1-SA-B	EM	-	30	-	16h6	5	3	5	-	216.5	176.5	40	8	3	90	70h7
102DC1-SA-B	EN	40	32	-	24h6	7	4	8	-	239	194	45	10	3	115	95h7
152DC1-SA-B	EN	40	32	-	24h6	7	4	8	-	261.5	216.5	45	10	3	115	95h7
202DC1-SA-B	EN	40	32	-	24h6	7	4	8	-	284	239	45	10	3	115	95h7
302DC1-SA-B	EO	55	46	-	28h6	7	4	8	-	308.5	245.5	63	12	6	145	110h7
402DC1-SA-B	EO	55	46	-	28h6	7	4	8	-	338.5	275.5	63	12	6	145	110h7
502DC1-SA-B	EO	55	46	-	28h6	7	4	8	-	368.5	305.5	63	12	6	145	110h7

(\*1) Screw hole (metric diameter x depth) of shaft extension (\*2) Insulating protection tube

(\*3) Shaft extension ( S) and flanged spigot ( LB) are machining finished with h6 or h7 fits.

(h) With providing brake, GYS slim type, (cont'd)  
 GYS300 to 502DC1-S8B, SB or SA-B type, 0.03 to 5 [kW]

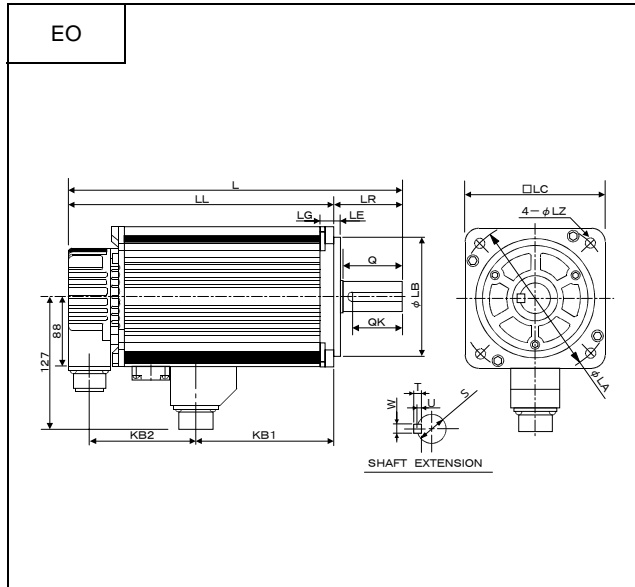

	LC	L1	L2	L3	LZ	IE	IL	C	KB1	KB2	Mass [kg]
-----	40	-	-	-	4.3	-	-	-	-	-	0.6
-----	40	-	-	-	4.3	-	-	-	-	-	0.7
-----	60	-	-	-	5.5	-	-	-	-	-	1.7
-----	60	-	-	-	5.5	-	-	-	-	-	2.3
-----	80	-	-	-	7	-	-	-	-	-	4.2
-----	100	-	-	-	9	-	-	-	79	96	5.9
-----	100	-	-	-	9	-	-	-	101.5	96	6.8
-----	100	-	-	-	9	-	-	-	124	96	7.9
-----	130	-	-	-	9	-	-	-	127.5	99	13.0
-----	130	-	-	-	9	-	-	-	157.5	99	15.5
-----	130	-	-	-	9	-	-	-	187.5	99	18.0

(i) With providing speed reduction gear unit, GYS slim type, gear ratio 1/9  
 GYS300 to 502DC1-S8B, SB or SA type, and gear head, 0.03 to 5 [kW]

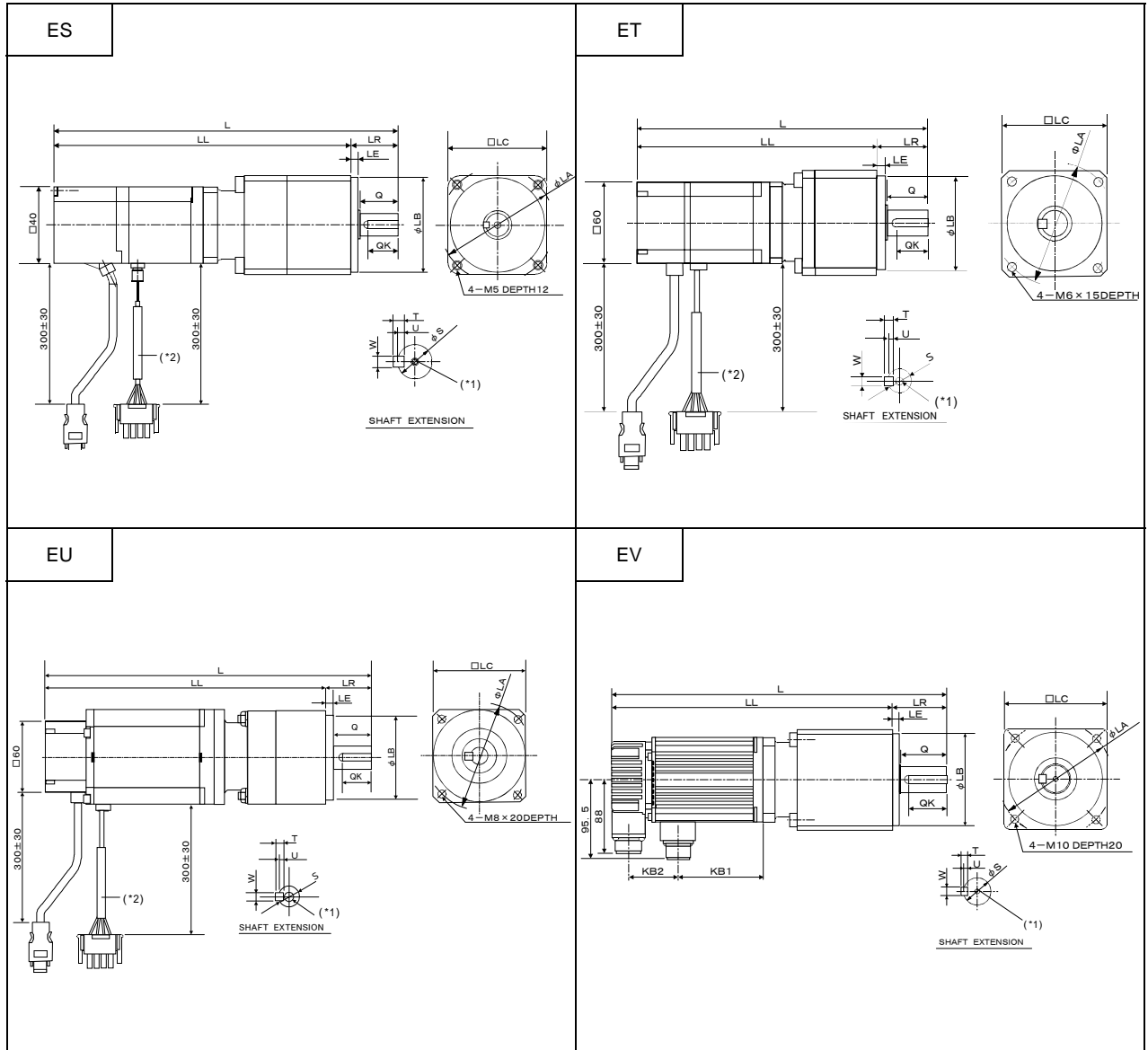

Type	Fig	Q	QK	QR	S (*3)	T	U	W	(*1)	L	LL	LR	LG	LE	LA	LB (*3)
GYS																
300DC1-S8B																
500DC1-S8B	ES	20	16	-	12h6	4	2.5	4		208	197	21	-	4	60	50h7
101DC1-SB	ES	20	16	-	12h6	4	2.5	4		236	215	21	-	4	60	50h7
201DC1-SA	ET	30	23	-	19h6	6	3.5	6	M4x8	232.5	195.5	37	-	6	90	70h7
401DC1-SA	ET	30	23	-	19h6	6	3.5	6	M4x8	260.5	223.5	37	-	6	90	70h7
751DC1-SA	EU	40	31	-	24h6	7	4	8	M6x15	306	257	49	-	8	115	90h7
102DC1-SA	EV	55	45	-	32h6	8	5	10		372	308	64	-	8	135	110h7
152DC1-SA	EV	55	45	-	32h6	8	5	10		394.5	330.5	64	-	8	135	110h7
202DC1-SA	EW	55	45	-	32h6	8	5	10		456	379	77	-	20	160	130h7
302DC1-SA																
402DC1-SA																
502DC1-SA																

(\*1) Screw hole (metric diameter x depth) of shaft extension (\*2) Insulating protection tube  
 (\*3) Shaft extension ( S) and flanged spigot ( LB) are machining finished with h6 or h7 fits.

(i) With providing speed reduction gear unit, GYS slim type, gear ratio 1/9 (cont'd)  
 GYS300 to 502DC1-S8B, SB or SA type, and gear head, 0.03 to 5 [kW]

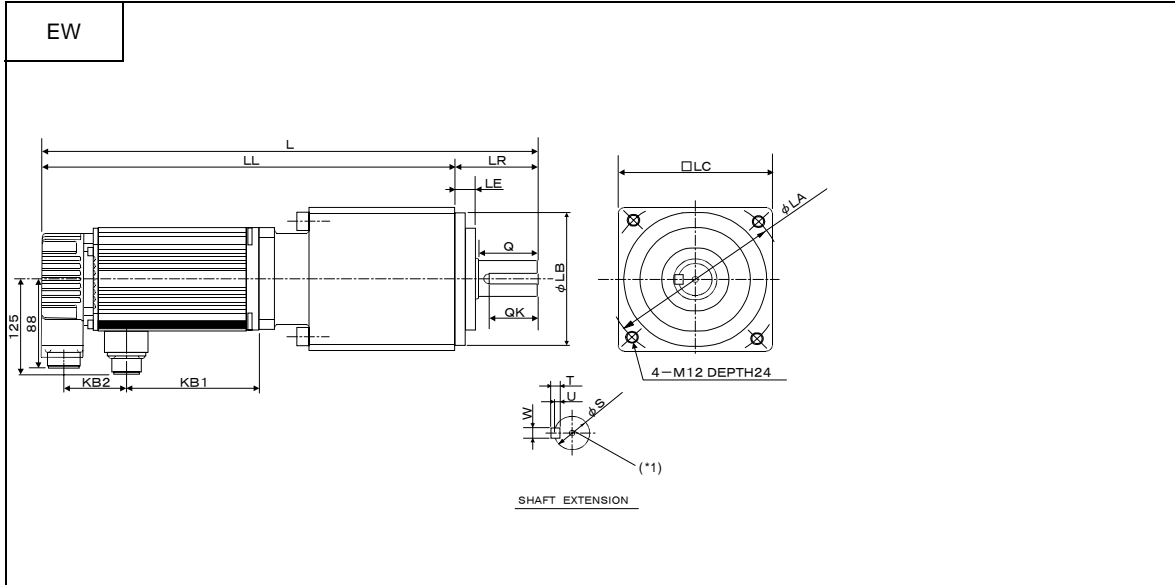

	LC	L1	L2	L3	LZ	IE	IL	C	KB1	KB2	Mass [kg]
---	52	-	-	-	-	-	-	-	-	-	1.15
---	52	-	-	-	-	-	-	-	-	-	1.25
---	78	-	-	-	-	-	-	-	-	-	3.3
---	78	-	-	-	-	-	-	-	-	-	3.9
---	98	-	-	-	-	-	-	-	-	-	7.2
---	120	-	-	-	-	-	-	-	77	57	12.2
---	120	-	-	-	-	-	-	-	99.5	57	13.0
---	140	-	-	-	-	-	-	-	122	57	18.5
---											
---											
---											

(j) With providing speed reduction gear unit, GYS slim type, gear ratio 1/25 or 1/15 ( for 102 to 202 types)  
 GYS300 to 502DC1-S8B, SB or SA type, and gear head, 0.03 to 5 [kW]

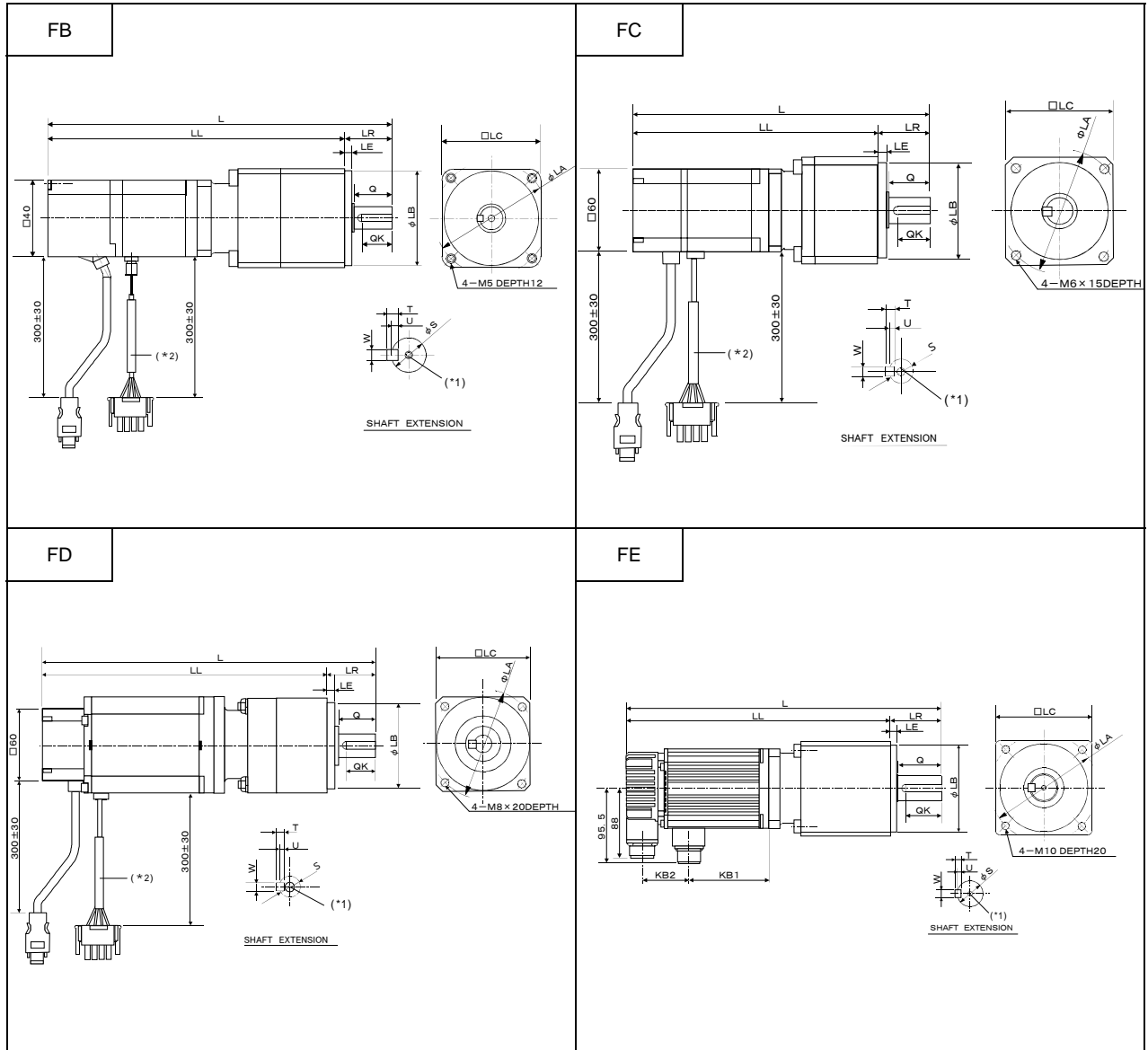

Type GYS	Fig	Q	QK	QR	S (*3)	T	U	W	(*1)	L	LL	LR	LG	LE	LA	LB (*3)
300DC1-S8B																
500DC1-S8B	FB	20	16	-	12h6	4	2.5	4		208	197	21	-	4	60	50h7
101DC1-SB	EB	20	16	-	12h6	4	2.5	4		236	215	21	-	4	60	50h7
201DC1-SA	FC	30	23	-	19h6	6	3.5	6	M4x8	232.5	195.5	37	-	6	90	70h7
401DC1-SA	FC	30	23	-	19h6	6	3.5	6	M4x8	260.5	223.5	37	-	6	90	70h7
751DC1-SA	FD	40	31	-	24h6	7	4	8	M6x15	306	257	49	-	8	115	90h7
102DC1-SA	FE	55	45	-	32h6	8	5	10		372	308	64	-	8	135	110h7
152DC1-SA	FE	55	45	-	32h6	8	5	10		394.5	330.5	64	-	8	135	110h7
202DC1-SA	FF	55	45	-	32h6	8	5	10		456	379	77	-	20	160	130h7
302DC1-SA																
402DC1-SA																
502DC1-SA																

(\*1) Screw hole (metric diameter x depth) of shaft extension (\*2) Insulating protection tube  
 (\*3) Shaft extension ( S) and flanged spigot ( LB) are machining finished with h6 or h7 fits.

(j) With providing speed reduction gear unit, GYS slim type, gear ratio 1/25 or 1/15 ( for 102 to 202 types) (cont'd)  
 GYS300 to 502DC1-S8B, SB or SA type, and gear head, 0.03 to 5 [kW]

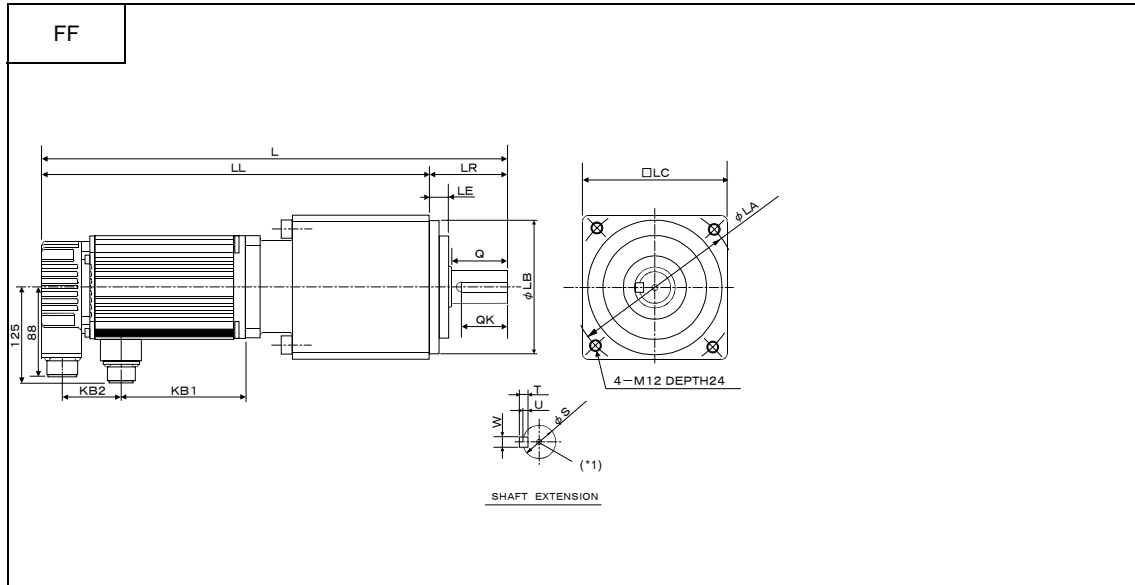

	LC	L1	L2	L3	LZ	IE	IL	C	KB1	KB2	Mass [kg]
---	52	-	-	-	-	-	-	-	-	-	1.15
---	52	-	-	-	-	-	-	-	-	-	1.25
---	78	-	-	-	-	-	-	-	-	-	3.3
---	78	-	-	-	-	-	-	-	-	-	3.9
---	98	-	-	-	-	-	-	-	-	-	7.2
---	120	-	-	-	-	-	-	-	77	57	12.2
---	120	-	-	-	-	-	-	-	99.5	57	13.0
---	140	-	-	-	-	-	-	-	122	57	18.5
---											
---											
---											

(k) Gear-head unit for GYS slim type motor, gear ratio 1/9  
 GYN300 to 101 and 751 to 502, GRN.20 to .40SAG-G09, 0.03 to 5 [kW]

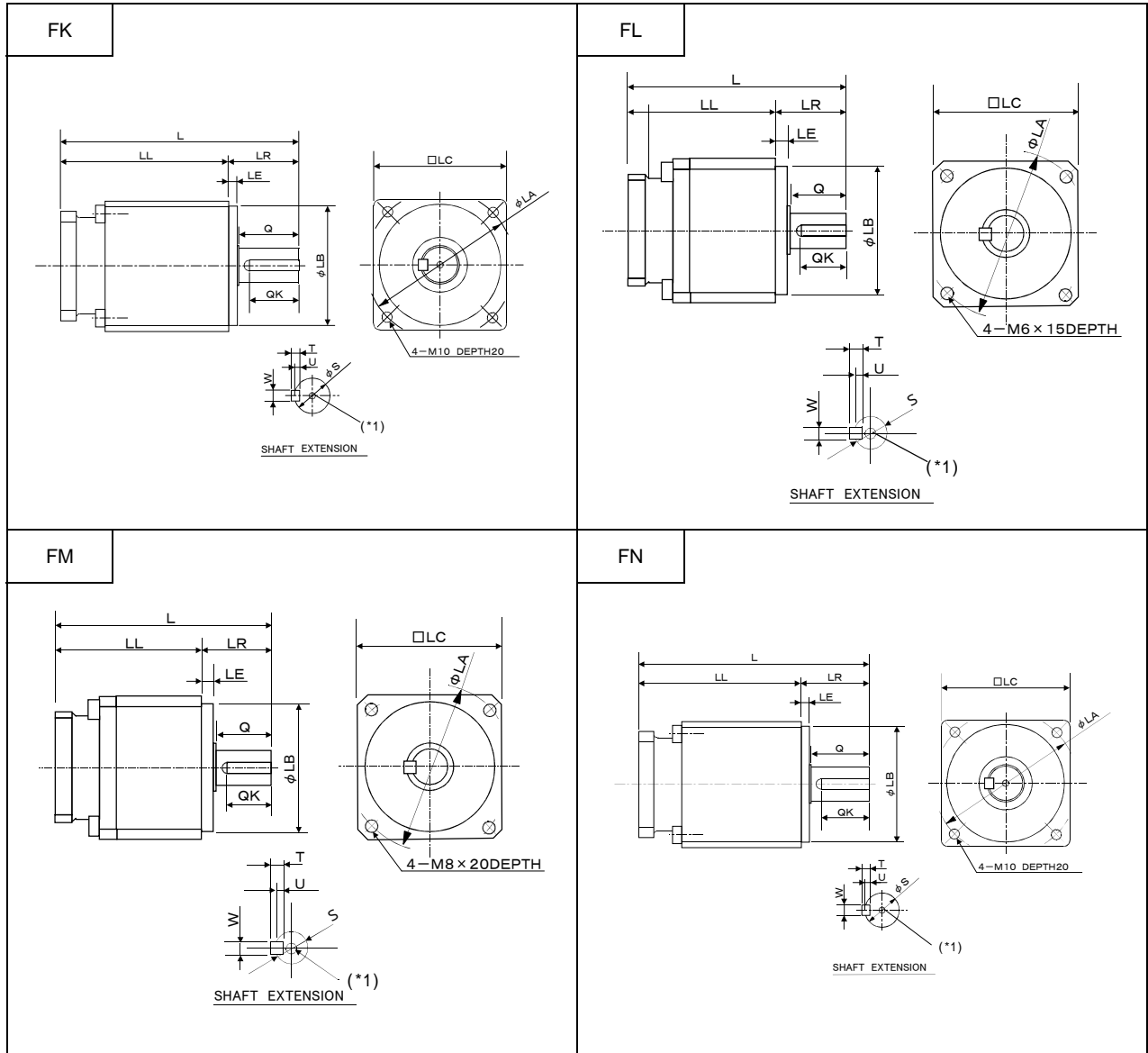

Type	Fig	Q	QK	QR	S	T	U	W	(*1)	L	LL	LR	LG	LE	LA	LB	LC	Mass [kg]
G09					(*3)													
GYN300SAG-																		
GYN500SAG-	FK	20	16	-	12h6	4	2.5	4		103	78	25	-	4	60	50h7	52	0.7
GYN101SAG-	FK	20	16	-	12h6	4	2.5	4		103	78	25	-	4	60	50h7	52	0.7
GRN.20SAG-	FL	30	23	-	19h6	6	3.5	6	M4x8	136	99	37	-	6	90	70h7	78	2.1
GRN.40SAG-	FL	30	23	-	19h6	6	3.5	6	M4x8	136	99	37	-	6	90	70h7	78	2.1
GYN751SAG-	FM	40	31	-	24h6	7	4	8	M6x15	166	117	49	-	8	115	90h7	98	3.9
GYN102SAG-	FN	55	45	-	32h6	8	5	10		219	155	64	-	8	135	110h7	120	7.8
GYN152SAG-	FN	55	45	-	32h6	8	5	10		219	155	64	-	8	135	110h7	120	7.8
GYN202SAG-	FO	55	45	-	32h6	8	5	10		258	181	77	-	20	160	130h7	140	12.2
GYN302SAG-																		
GYN402SAG-																		
GYN502SAG-																		

(\*1) Screw hole (metric diameter x depth) of shaft extension

(\*3) Shaft extension ( S ) and flanged spigot ( LB ) are machining finished with h6 or h7 fits.

(k) Gear-head unit for GYS slim type motor, gear ratio 1/9 (cont'd)  
GYN300 to 101 and 751 to 502, GRN.20 to .40SAG-G09, 0.03 to 5 [kW]

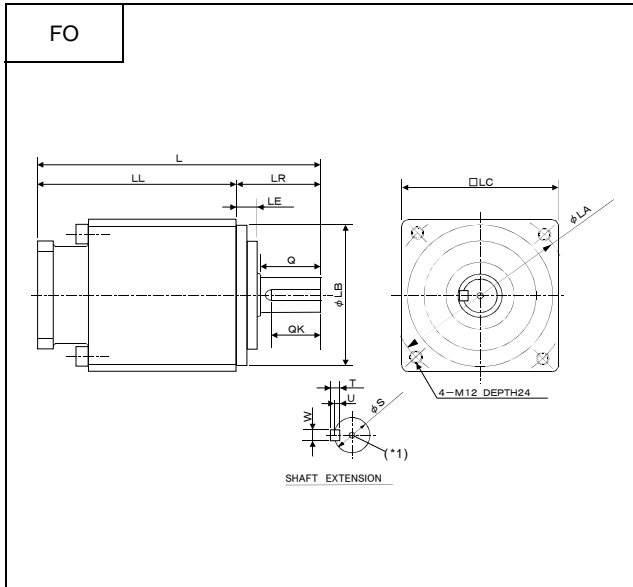

(I) Gear-head unit for GYS slim type motor, gear ratio 1/25 (for 300 to 751 types) or 1/15 (for 102 to 502 types)  
 GYN300 to 101 and 751 to 502, GRN.20 to .40SAG-G25 or G15, 0.03 to 5 [kW]

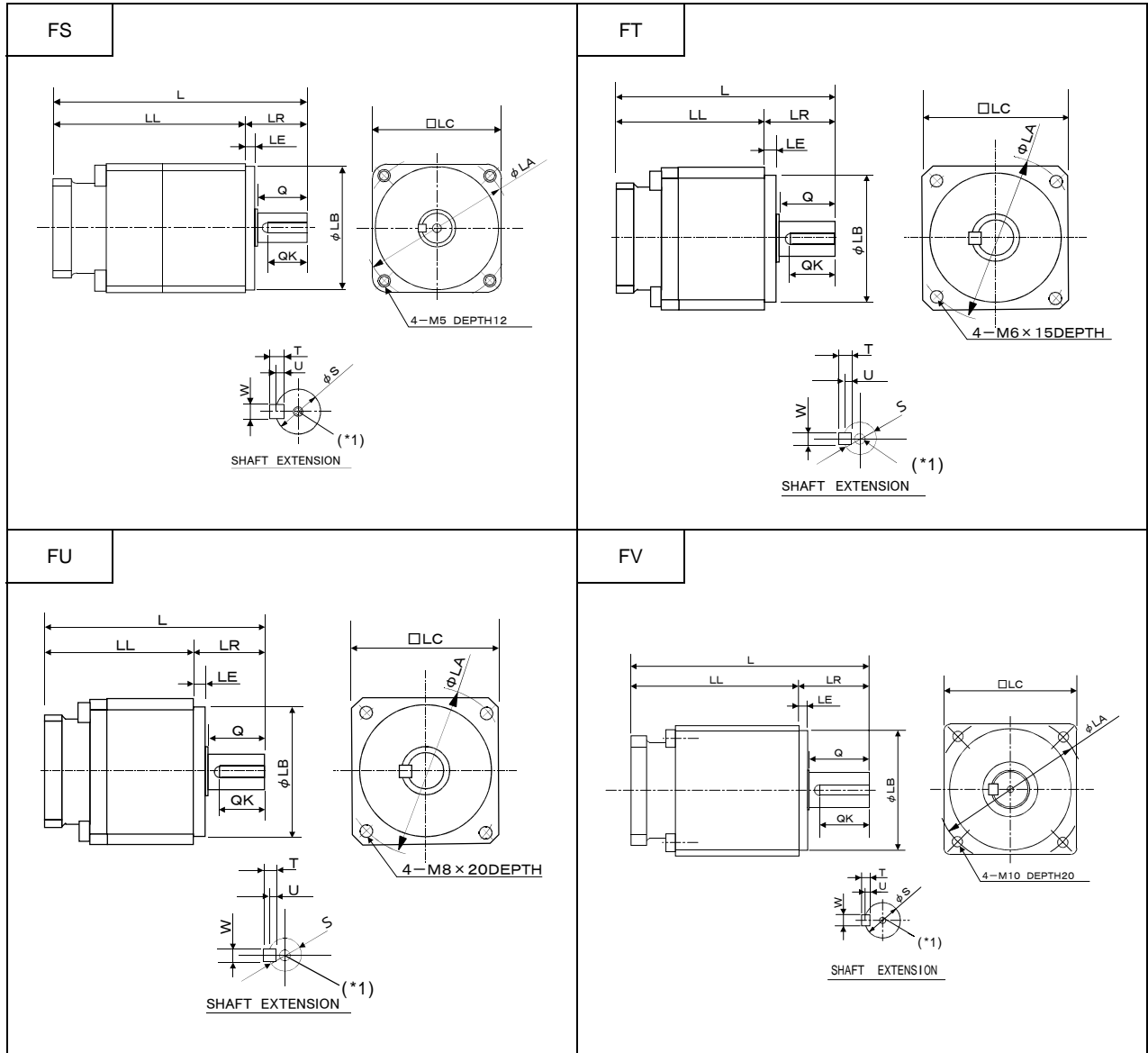

Type	Fig	Q	QK	QR	S (*3)	T	U	W	(*1)	L	LL	LR	LG	LE	LA	LB (*3)	LC	Mass [kg]
GYN300SAG-G25																		
GYN500SAG-G25	FS	20	16	-	12h6	4	2.5	4		103	78	25	-	4	60	50h7	52	0.7
GYN101SAG-G25	FS	20	16	-	12h6	4	2.5	4		103	78	25	-	4	60	50h7	52	0.7
GRN.20SAG-G25	FT	30	23	-	19h6	6	3.5	6	M4x8	136	99	37	-	6	90	70h7	78	2.1
GRN.40SAG-G25	FT	30	23	-	19h6	6	3.5	6	M4x8	136	99	37	-	6	90	70h7	78	2.1
GYN751SAG-G25	FU	40	31	-	24h6	7	4	8	M6x15	166	117	49	-	8	115	90h7	98	3.9
GYN102SAG-G15	FV	55	45	-	32h6	8	5	10		219	155	64	-	8	135	110h7	120	7.8
GYN152SAG-G15	FV	55	45	-	32h6	8	5	10		219	155	64	-	8	135	110h7	120	7.8
GYN202SAG-G15	FW	55	45	-	32h6	8	5	10		258	181	77	-	20	160	130h7	140	12.2
GYN302SAG-G15																		
GYN402SAG-G15																		
GYN502SAG-G15																		

(\*1) Screw hole (metric diameter x depth) of shaft extension

(\*3) Shaft extension ( S ) and flanged spigot ( LB ) are machining finished with h6 or h7 fits.

(I) Gear-head unit for GYS slim type motor, gear ratio 1/25 (for 300 to 751 types) or 1/15 (for 102 to 502 types) (cont'd)  
GYN300 to 101 and 751 to 502, GRN.20 to .40SAG-G25 or G15, 0.03 to 5 [kW]

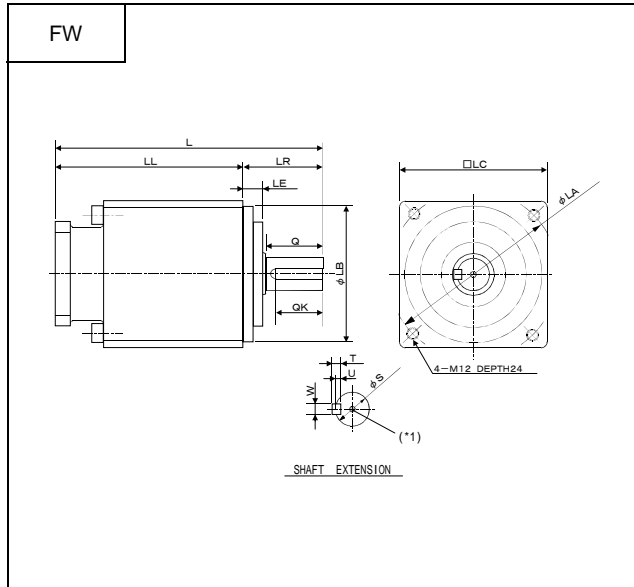

**(2) Motor, flange-mounted, for 100 [V] class input voltage of amplifier**

(a) Basic design, GYS slim type

GYS300 to 201DC1-S8B or S6B type, 0.03 to 0.2 [kW]

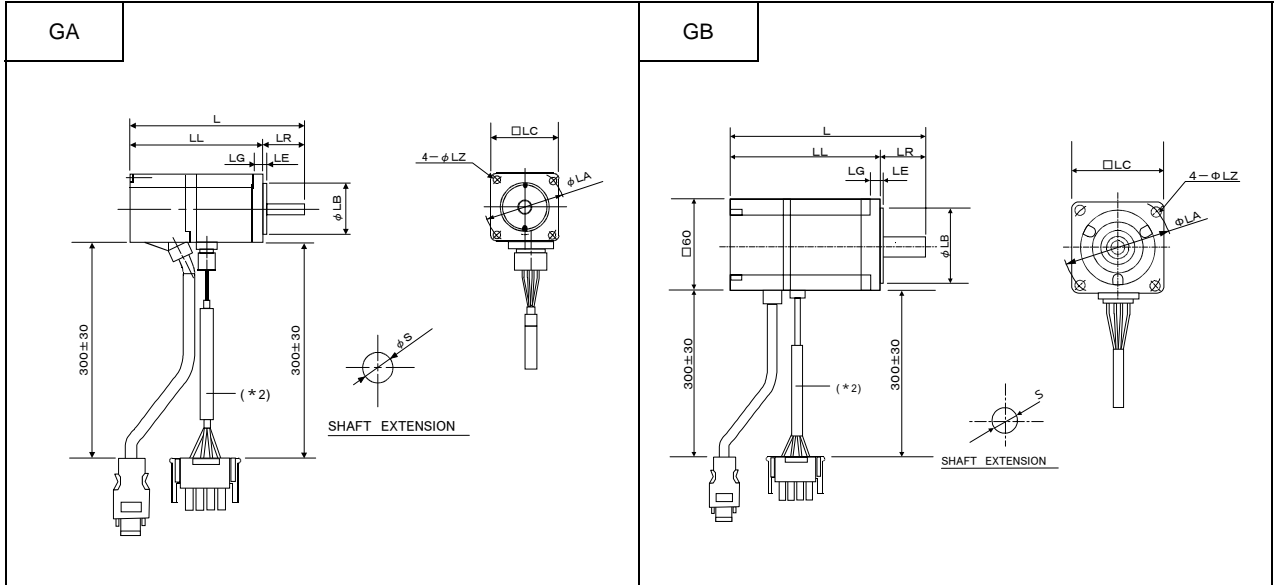

Type	Fig	QK	S (*3)	T	U	W	L	LL	LR	LG	LE	LA	LB (*3)	DLC	LZ	Mass [kg]
GYS																
300DC1-S8B																
500DC1-S8B	GA	-	6h6	-	-	-	103	78	25	5	2.5	46	30h7	40	4.3	0.45
101DC1-S6B	GB	-	8h6	-	-	-	121	96	25	5	2.5	46	30h7	40	4.3	0.55
201DC1-S6B	GB	-	14h6	-	-	-	126.5	96.5	30	6	3	70	50h7	60	5.5	1.2

(\*2) Insulating protection tube

(\*3) Shaft extension ( S) and flanged spigot ( LB) are machining finished with h6 or h7 fits.

(b) With providing brake, GYS slim type  
 GYS300 to 201DC1-S8B or S6B-B type, 0.03 to 0.2 [kW]

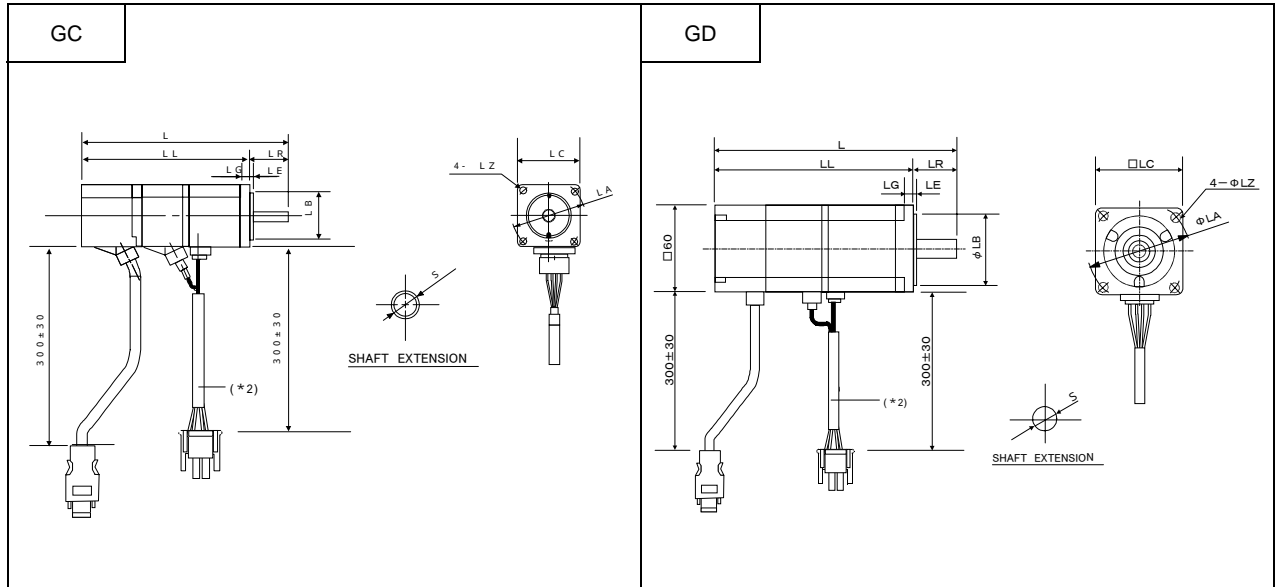

Type	Fig	QK	S (*3)	T	U	W	L	LL	LR	LG	LE	LA	LB (*3)	DLC	LZ	Mass [kg]
GYS																
300DC1-S8B-B																
500DC1-S8B-B	GC	-	6h6	-	-	-	140	115	25	5	2.5	46	30h7	40	4.3	0.6
101DC1-S6B-B	GD	-	8h6	-	-	-	158	133	25	5	2.5	46	30h7	40	4.3	0.7
201DC1-S6B-B	GD	-	14h6	-	-	-	165	135	30	6	3	70	50h7	60	5.5	1.7

(\*2) Insulating protection tube

(\*3) Shaft extension ( S ) and flanged spigot ( LB ) are machining finished with h6 or h7 fits.

**(3) RYS amplifier**

(a) 200 [V] class input voltage of amplifier

(i) 0.03 to 0.2 [kW]

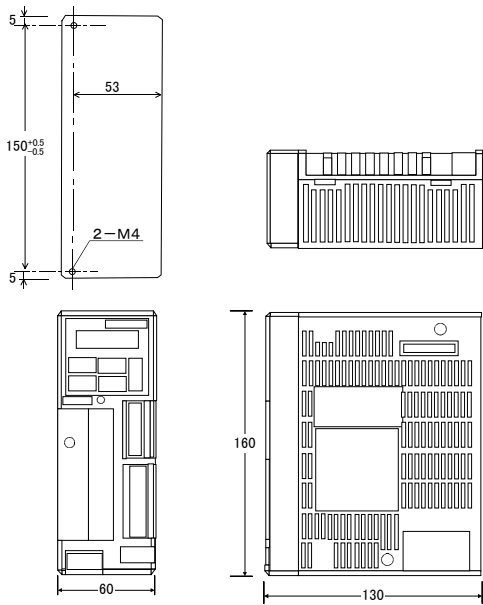

(ii) 0.4 [kW]

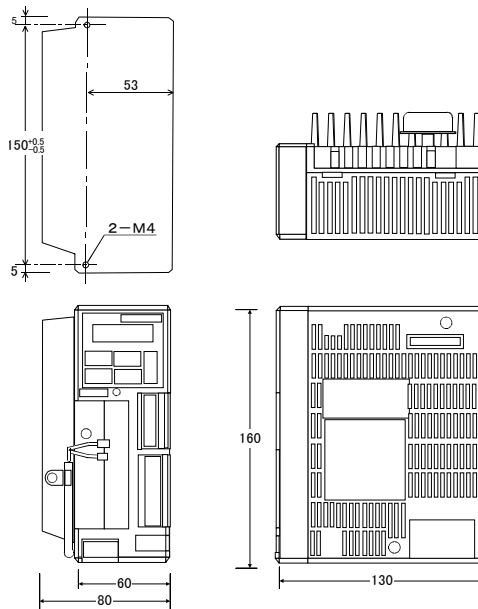

(iii) 0.75 [kW]

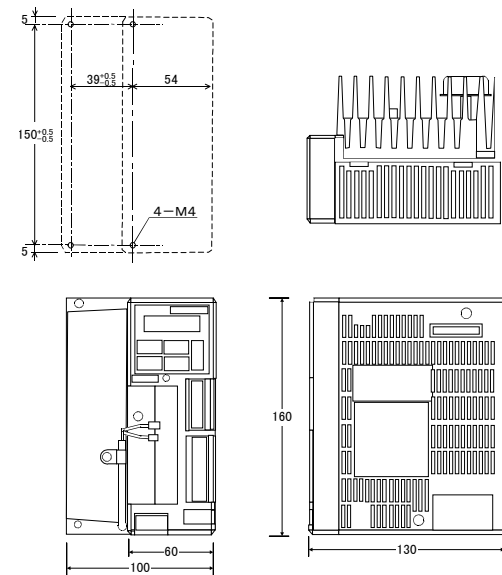

(iv) 1, 1.5 [kW]

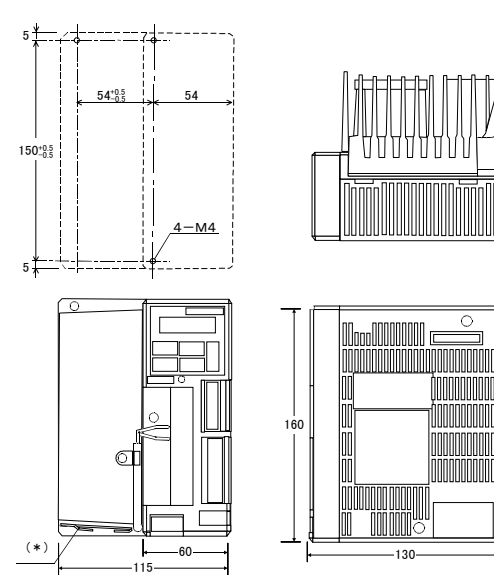

(\*) Ventilation cooling fan

(v) 2, 3 [kW]

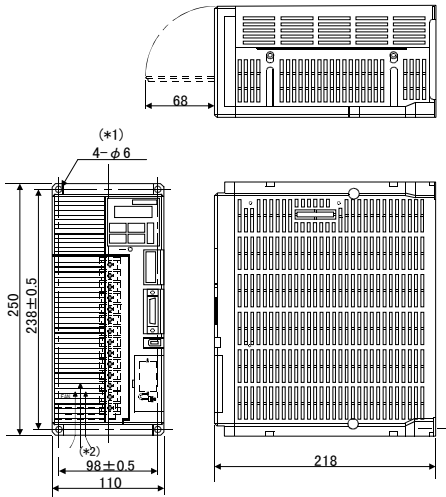

(vi) 4, 5 [kW]

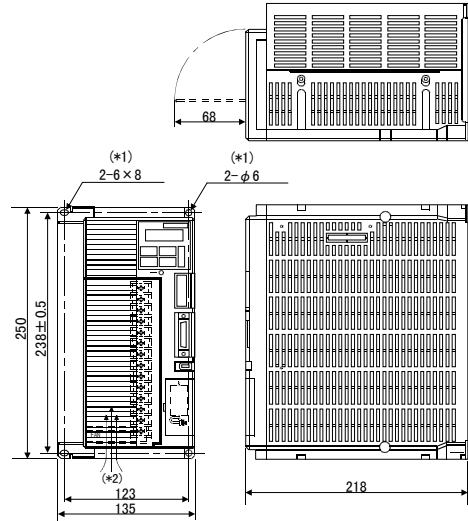

(\*1) Panel mounting hole  
 (\*2) Ventilation cooling-air inlet

(b) 100 [V] class input voltage of amplifier  
 (i) 0.05, 0.1 [kW]

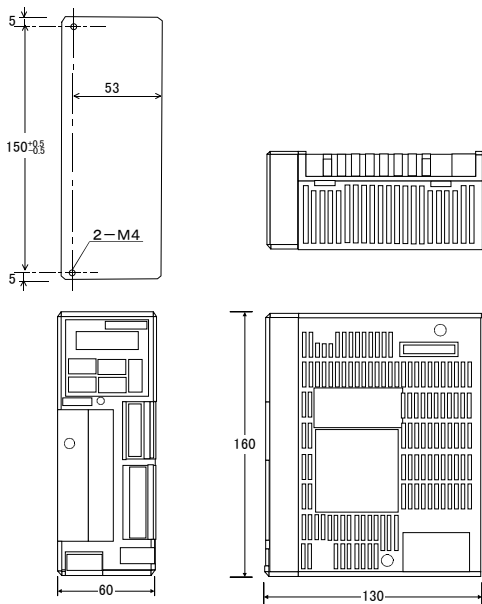

(ii) 0.2 [kW]

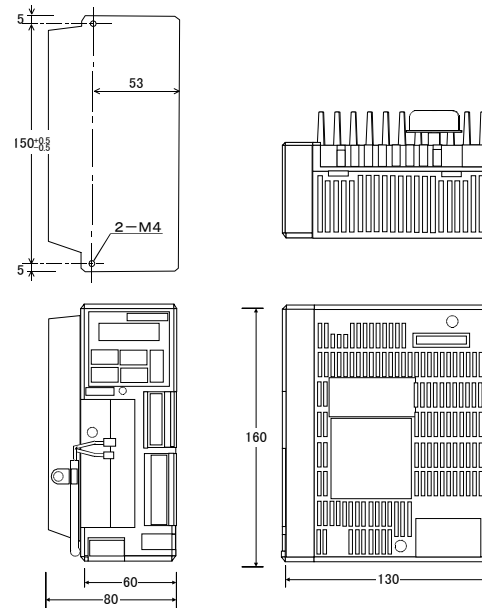

#### 4. TERMINAL DIAGRAMS AND WIRING

##### 4.1 Amplifier, motor and optional devices layout

###### (1) Amplifier

(a) 0.03 to 1.5 [kW]

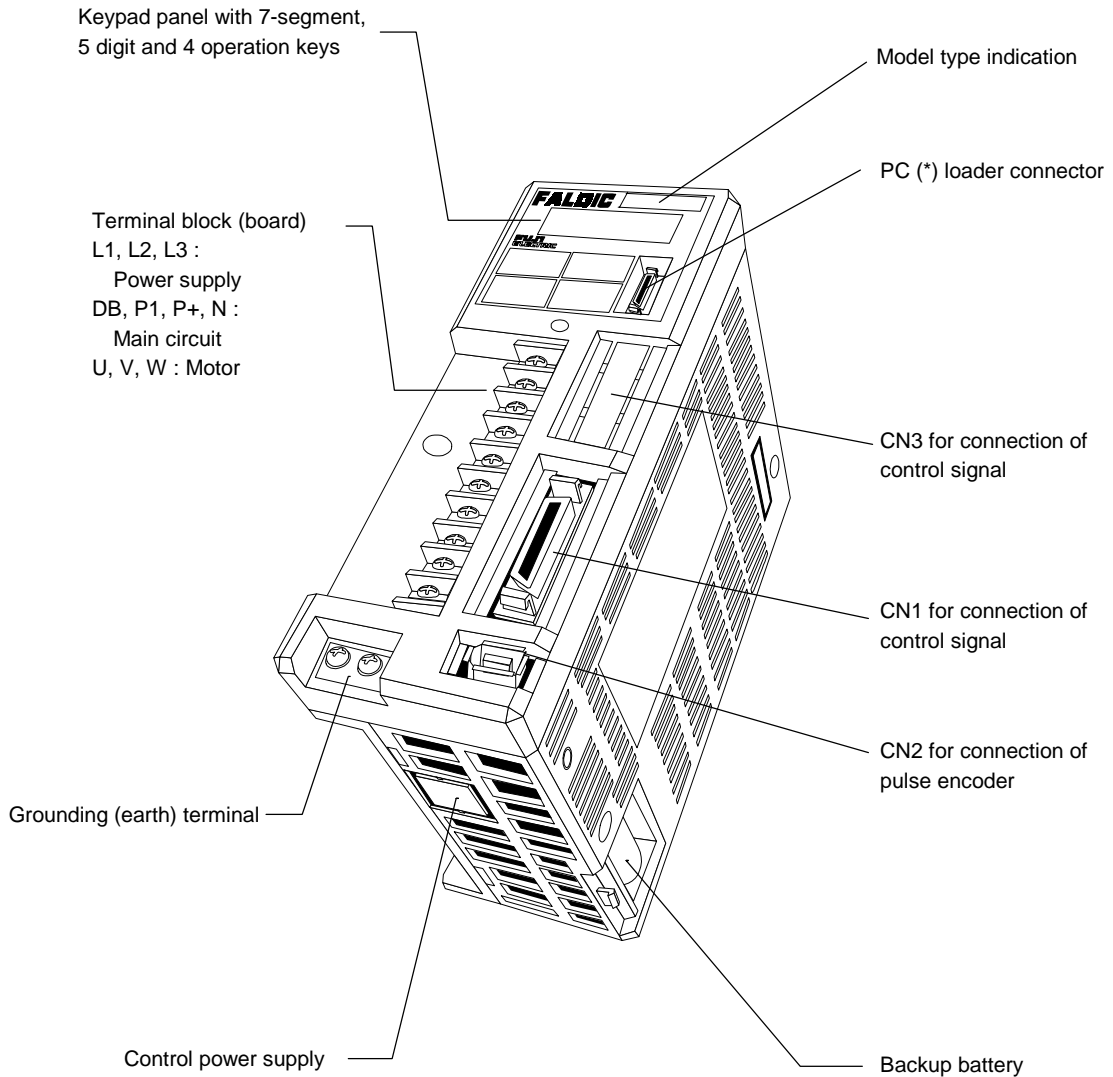

Remark : Actual amplifier may differ in details.

(\*) PC : Personal computer

**(1) Amplifier (cont'd)**  
 (b) 2 to 5 [kW]

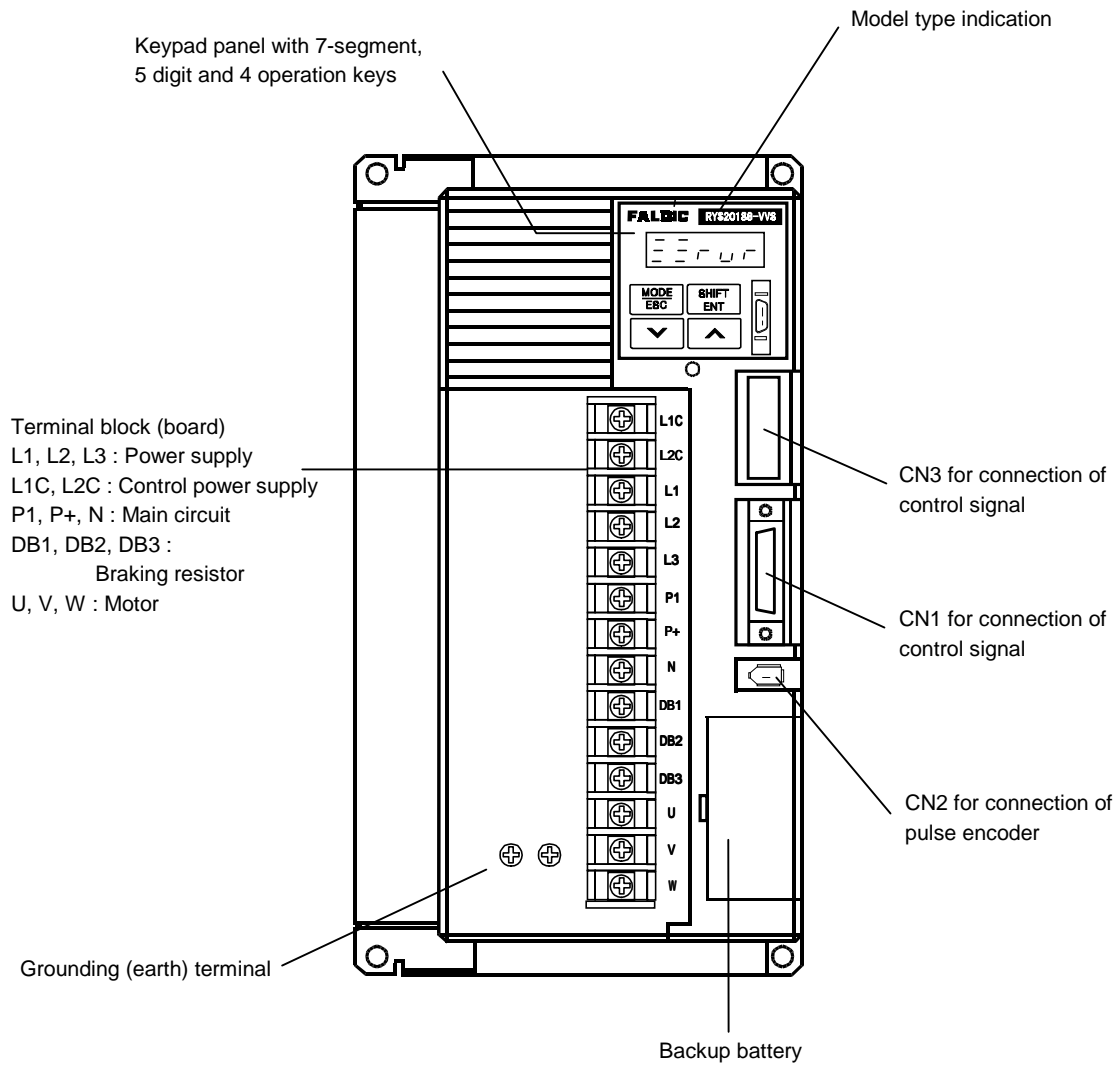

Remarks :

- (1) This figure indicates the state where the cover of terminal block (board) is open. The cover should be closed before power on.
- (2) Actual amplifier may differ in details.

**(2) Motor**

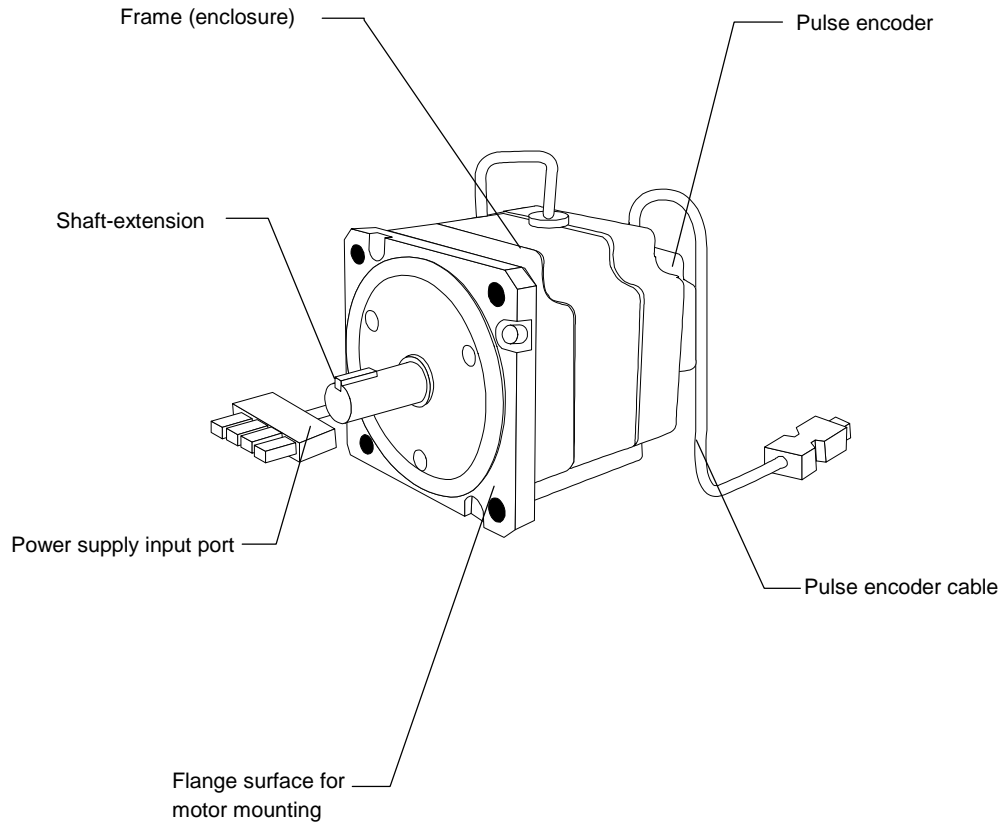

Remark : Actual motor may differ in details.

(3) **Optional devices** : See the next page.

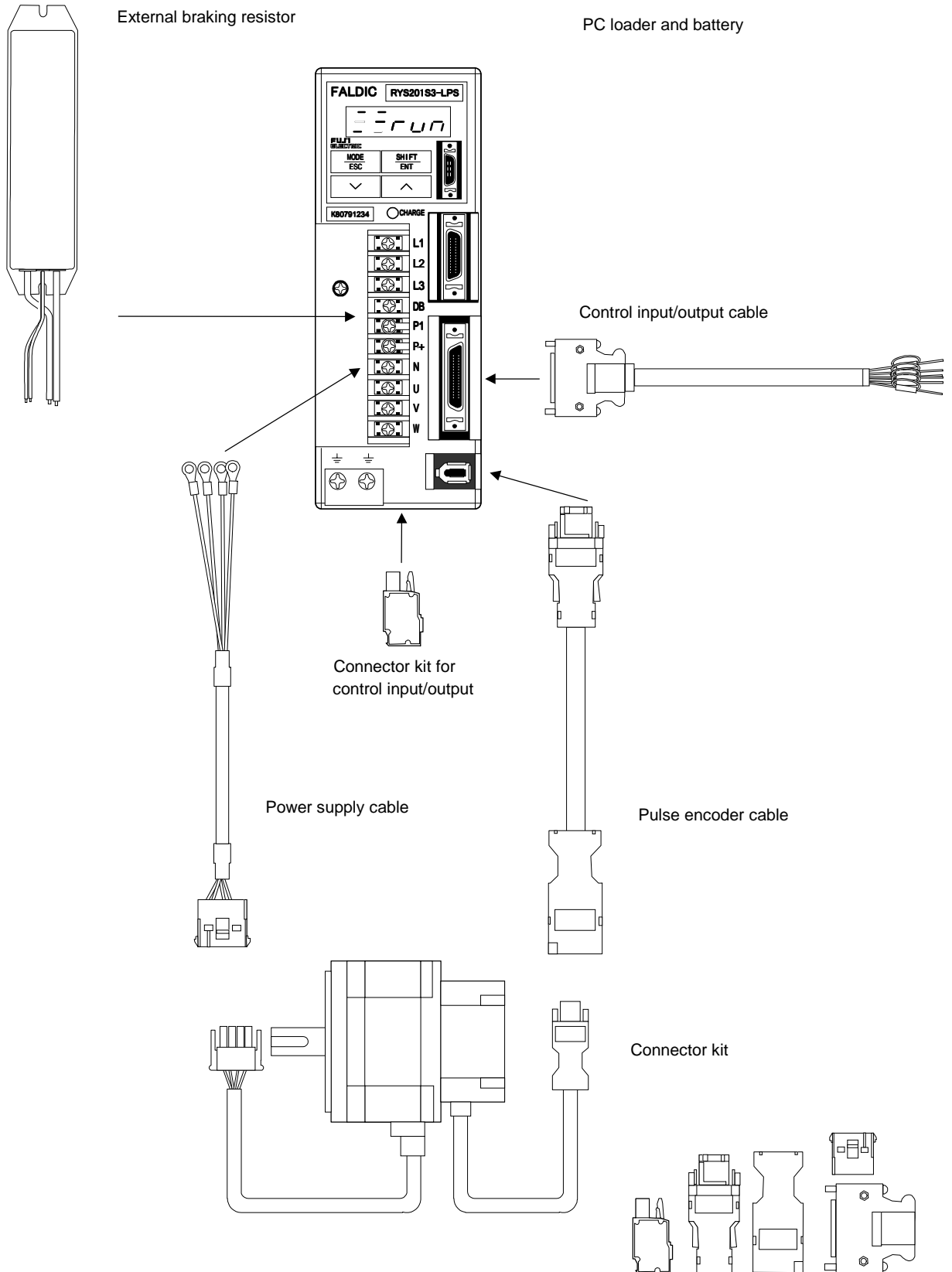

**Optional cables, connector kits, battery and external braking resistors** : See 11.8 Optional cables, connector kits, battery and external braking resistors.

Reference letter or figure : See preceding page	Description (*)										Type			
11.8														
(1)	a	Control cable		Expanded (CN3) for L, R type amplifier			3 [m] lg.			WSC - D20P03 D26P03 D36P03				
	b			SX bus, T-link, RS485 types (CN1)										
	c			Basic type (DI/DO) (CN1)										
	d	Pulse encoder cable		Molex-Molex (*)	0.75 [kW] and below		5 [m] lg.			P06P05				
							10 [m] lg.			P06P10				
							20 [m] lg.			P06P20				
				e	Molex-Canon (*)	1 [kW] and above		5 [m] lg.			P06P05-C			
								10 [m] lg.			P06P10-C			
								20 [m] lg.			P06P20-C			
	f	Molex (*)	Provide the connector connection for motor by others		5 [m] lg.			P06P05-W						
					10 [m] lg.			P06P10-W						
					20 [m] lg.			P06P20-W						
g	Power supply cable		Motor without brake	AMP (*)	0.75 [kW] and below		5 [m] lg.			M04P05				
							10 [m] lg.			M04P10				
							20 [m] lg.			M04P20				
			h	Motor with brake	AMP (*)			5 [m] lg.			M06P05			
								10 [m] lg.			M06P10			
								20 [m] lg.			M06P20			
(2)	a	Connector kit		Control (CN1, CN3)		Expanded (CN3) for L, R type amplifier			WSK - D20P D26P D36P					
	b					SX bus, T-link, RS485 types (CN1)								
	c					Basic type (DI/DO) (CN1)								
	d	Pulse encoder (CN2)		Molex (*) (amplifier side)	0.75 [kW] and below					P06P-M				
							e	Molex (*) (motor side)				P06P-F		
									f	Canon (*)	1 [kW] and above		P06P-C	
	g	Motor without brake		AMP (*)	0.75 [kW] and below						M04P			
							h	Canon (*)	GYS, 1 to 2 [kW]		} and above		M04P-CA	
									GYS, 1 [kW]					
				GYS, 3 [kW]		M04P-CB								
				i	Motor with brake		AMP (*)	0.75 [kW] and below					M06P	
										j	Canon (*)	GYS, 1 to 2 [kW]		M06P-CA
GYS, 1 [kW]		M06P-CB												
k														
						GYS, 3 [kW]								
(3)	a	External braking resistor			0.4 [kW] and below			WSR- 401						
	b				0.75 [kW]			751						
	c				1, 1.5 [kW]			152						
	d				2, 3 [kW]			DB11-2						
	e				4, 5 [kW]			DB22-2						
	PC loader										WSL - PC			
	Loader cable, 2 [m] lg.										NP4H- CNV			
(2)	n	Battery										WSB - S		
	m	Connector kit	Control		1.5 [kW] and below			WSK - L02P						
	SX bus cables		Type	NP1C-	P3	P6	P8	02	05	10	25			
			Cable lg.	[m]	0.3	0.6	0.8	2	5	10	20			

(\*) lg. : Cable length

Molex, Canon, AMP : Supplier's product name of connector and terminal

## 4.2 Commercial power supply

Supply commercial power to the amplifier.

### (1) Power supply

(a) 200 [V] 3-phase input voltage of amplifier

Supply 200 [V] commercial power to the amplifier.

Connect it to terminals L1, L2 and L3.

- Voltage : 200/200-220-230 [V] +10%/ -15%.
- Frequency : 50/60 [Hz]
- Phase : 3-phase (main circuit power supply) / single-phase (control power supply)

(b) 100 [V] single-phase input voltage of amplifier

Supply 100 [V] commercial power to the amplifier.

Connect it to terminals L1 and L2.

- Voltage : 100 to 115 [V] +10%/ -15%
- Frequency : 50/60 [Hz]
- Phase : Single-phase (main circuit and control power supply)

### (2) Power supply capacity

The power supply capacity required for each amplifier is as follows.

The power supply capacity is applied for cabling with specified cable and 20 [m] max. wiring length. If the power capacity is 500 [kVA] or more, AC reactor for impedance matching should be provided. See 11.5 AC reactor (reactor for impedance matching).

(a) 200 [V] 3-phase input voltage of amplifier

Amplifier type	RYS	S3	500	101	201	401	751	102	152	202	302	402	502
Motor type (example)	GYS	DC1- S8B, SB or SA	500 S8B	101 SB	201 SA	401	751	102	152	202	302	402	502
Motor output		[kW]	0.05	0.1	0.2	0.4	0.75	1	1.5	2	3	4	5
Power capacity		[kVA]	0.15		0.6	1.2	1.8	3	4.5	6	9	10	15

(b) 100 [V] single-phase input voltage of amplifier

Amplifier type	RYS	S3- * * * 6	500	101	201
Motor type (example)	GYS	DC1- S8B, S6B	500 S8B	101 S6B	201
Motor output		[kW]	0.05	0.1	0.2
Power capacity		[kVA]	0.15	0.6	1.2

### (3) Harmonics suppression

If a (harmonics suppressing) reactor is connected to RYS type amplifier, see 11.5 AC reactor or 11.7 DC reactor.

**(4) Control power supply input**

The wiring procedure for control power supply of 1.5 [kW] and below is as follows.

**(a) Connector**

Use a connector of WSK-L02P type. See (3) of 4.1 Amplifier, motor and optional devices layout and (2) m of 11.8 Optional cables, connector kits, battery and external braking resistors.

**(b) Wiring**

Remove the insulation covering of wire by approx. 13 [mm] length and, while strongly pressing the arrow part in the figure by the operation lever furnished with the connector or flat head screwdriver, insert the wire.

After connecting 2 wires, engage the connector with the control power supply and amplifier.

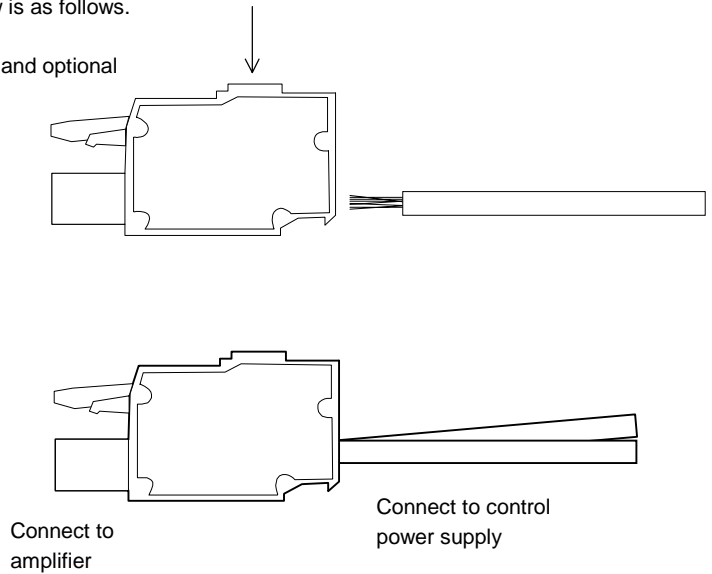

**4.3 Wiring between motor and pulse encoder**

**(1) Motor wiring**

Connect the power line of the motor to the output U, V, W terminals of the amplifier.

Do not connect commercial power supply to the motor terminals.

The direction of rotation of the motor cannot be changed by changing the phase sequence of the motor terminals. It can be achieved by system para.



**CAUTION**

**Do not connect commercial power supply directly to the motor. Otherwise, motor may break.**

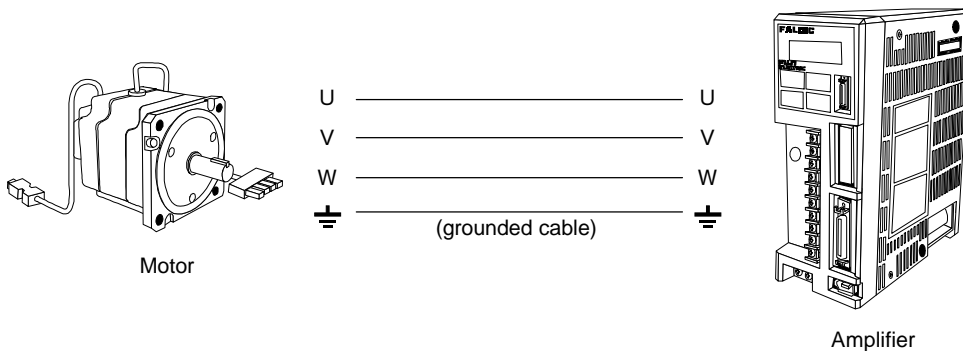

The wiring length between amplifier and motor should be within 50 [m].

It is not permitted to perform on/off of the wiring between the amplifier and motor by magnetic contactors. It is not permitted to turning on/off multiple motors with a single amplifier.

Furthermore, it is not permitted to wiring the following equipment along the wiring between amplifier and motor :

Phase advancing capacitor, reactor, power filter, surge suppressor (surge killer)

Terminal workings of motor power supply cables are as follows :

(a) GYC/GYS type motor : 0.75 [kW] and below

(i) Motor without providing brake

• Viewed from socket inserting side

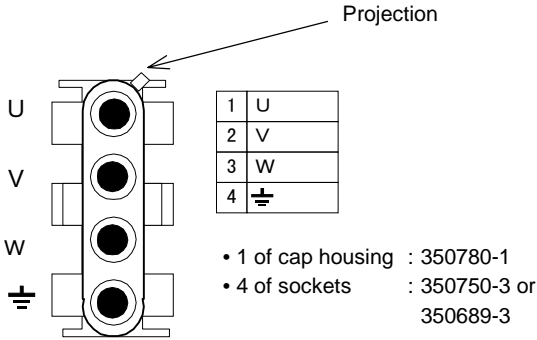

(ii) Motor with providing brake

• Viewed from socket inserting side

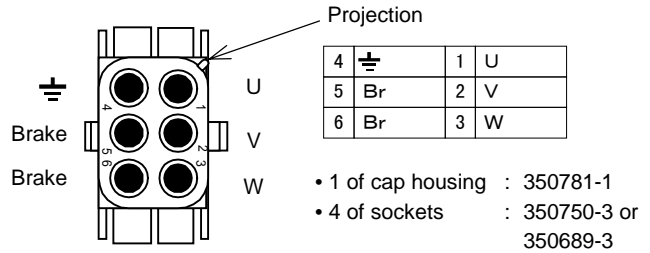

(b) GYC/GYS type motor : 1 [kW] and above

(i) Motor without providing brake

• View of plug wiring side

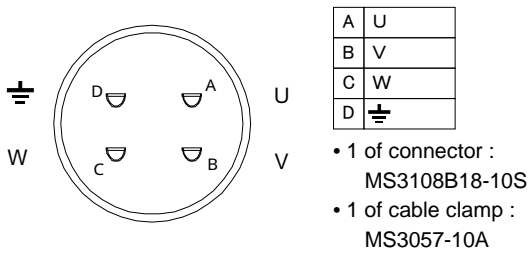

(ii) Motor with providing brake

• View of plug wiring side

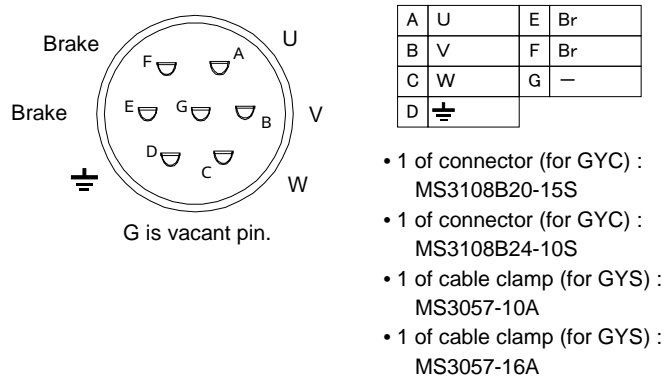

## (2) Pulse encoder wiring

Connect the pulse encoder wiring to CN2 of the amplifier.

The wiring length between amplifier and encoder should be within 50 [m].

(a) 0.75 [kW] and below (GYC/GYS type motor)

(i) Wiring to amplifier

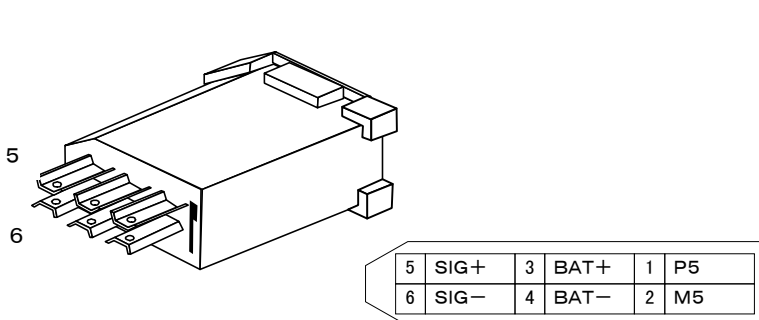

• View of housing wiring side

- Housing : 54180-0611
- Shell body clamp : 58299-0600
- Shell body cover : 58300-0600
- Mold cover : 54181-0615
- Mold cover : 54182-0605
- Cable clamp : 58303-0000
- Clamp screw (M2x4) : 59832-0009

(ii) Wiring to motor

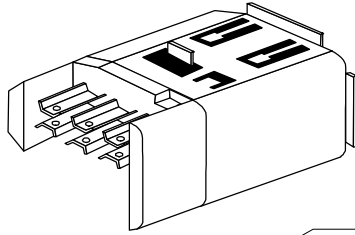

6	SIG-	4	BAT-	2	M5
5	SIG+	3	BAT+	1	P5

• View of housing wiring side

Housing	: 53988-0611
Shell body clamp	: 58302-0600
Mold cover	: 53989-0605
Mold cover	: 53990-0650
Cable clamp	: 58303-0000
Clamp screw (M2x4)	: 53982-0009

(b) 1 [kW] and above (GYC/GYS type motor)

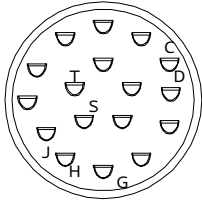

H	P5
G	M5
C	SIG+
D	SIG-
T	BAT+
S	BAT-
J	Shield

• View of housing wiring side

1 of connector :  
MS3108B20-29S  
1 of cable clamp :  
MS3057-12A

(c) Wiring cable

If the optional pulse encoder wiring cable is not used, use wiring with the following cable or equivalent.

- Cross-link polyethylene insulated, vinyl sheath cable :

AWG No.25 / 2P+AWG No.23/2C (\*), (twisted-pair cable), RMCV-SB (UL2464) type

The wiring length should be within 20 [m].

- Cross-link polyethylene insulated, vinyl sheath cable :

AWG No.25 / 2P+AWG No.16/2C (\*), (twisted-pair cable), RMCV-SB (UL2464) type

The wiring length should be within 50 [m].

(\* ) 2P (pairs), 2C (core) twisted-pair cable of different wire sizes. Use the enlarged sectional area of wires for power supply.

(d) Connection

It is not allowed to extend the wiring distance by connecting two or more cables of short wiring length.



**CAUTION**

**Do not extend the wiring distance by connecting two or more encoder wiring cables.  
A voltage drop by contact resistance of connector may stop the operation abruptly.**

Remark : The wire size conversion between AWG and [mm] is as follows.

Gauge		Diameter		Sectional area	
A W G	mm G	mil	mm	Circular mil	mm <sup>2</sup>
				CM	mm <sup>2</sup>
16	1.4	55.12	1.400	3038	1.539
	1.2	50.82	1.291	2583	1.309
		47.24	1.200	2232	1.131
23	.55	22.57	0.5773	509.4	0.2581
		21.65	0.5500	468.7	0.2376
24	.50	20.10	0.5106	404.0	0.2047
		19.69	0.5000	387.7	0.1963
25	.45	17.90	0.4547	320.4	0.1623
		17.72	0.4500	314.0	0.1590

#### 4.4 Host interface (I/F)

Connect signals to and from host controller to RYS-L type amplifier are as follow :

- Basic type (DI/DO position)
- SX bus type (SX bus direct connection)
- T-link type (T-link direct connection)
- General-purpose communication (RS485 interface)

##### (1) Basic type (DI/DO position)

RYS S3-LPS type amplifier operates in accordance with the control input signal (CONTn) at CN3 and CN1. Control output signal (OUTn) is directed to the host controller.

Signal (immediate positioning and current positioning etc.) between amplifier and host controller transmits using DI/DO level of DC +24 [V]. PLC output is of 21 points and PLC input is of 10 points (at maximum) per axis.

(a) CN3 (upper side)

Connect control input/output signals.

2	P 2 4	1	M 2 4	12	OUT 6	11	OUT 7
4	CONT14	3	CONT15	14	OUT 8	13	OUT 9
6	CONT16	5	CONT17	16	CONT 9	15	OUT 10
8	CONT18	7	CONT19	18	CONT11	17	CONT10
10	CONT20	9	CONT21	20	CONT13	19	CONT12

Plug : 10120-3000VE  
Shell kit : 10320-52A0-008

(b) CN1 (lower side)

Connect control input/output signals.

35	C A	36	* C A	17	N R E F	18	M 5
33	C B	34	* C B	15	-	16	MON 1
31	F A	32	* F A	13	M 5	14	MON 2
29	F B	30	* F B	11	P 1 0	12	B A T -
27	F Z	28	* F Z	9	M 5	10	B A T +
25	M 5	26	OUT 3	7	OUT 4	8	OUT 5
23	CONT 7	24	CONT 8	5	OUT 1	6	OUT 2
21	CONT 1	22	CONT 2	3	CONT 5	4	CONT 6
19	M 2 4	20	P 2 4	1	CONT 3	2	CONT 4

Plug : 10136-3000VE  
Shell kit : 10336-52A0-008

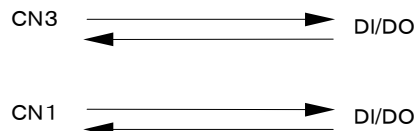
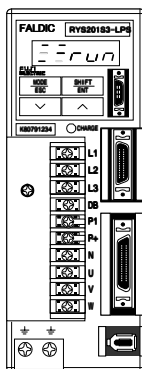

(c) Terminal function  
 (i) CN3 (upper side)

Terminal symbol	Connector pin No.	Terminal name	Function
P24 M24	2 1	Control power supply	+24 [V] DC, 0.2 [A]
CONT9 CONT10 CONT11 CONT12 CONT13 CONT14 CONT15 CONT16 CONT17 CONT18 CONT19 CONT20 CONT21	16 17 18 19 20 4 3 6 5 8 7 10 9	Control input	+24 [V] DC, 10 [mA] Initially assigned at factory : CONT 9 : — CONT10 : LS (origin LS) CONT11 : +0T (+ direction overtravel) CONT12 : -0T (- direction overtravel) CONT13 : EMG (forced stop) CONT14 : AD0 CONT15 : AD1 CONT16 : AD2 CONT17 : AD3 CONT18 : AD4 CONT19 : AD5 CONT20 : AD6 CONT21 : AD7
OUT6 OUT7 OUT8 OUT9 OUT10	12 11 14 13 15	Control output	+30 [V] DC, 50 [mA] max. Initially assigned at factory : OUT6 : — OUT7 : — OUT8 : — OUT9 : — OUT10 : —

## (ii) CN1(lower side)

Terminal symbol (*1)	Connector pin No.	Terminal name	Function
P24 M24	20 19	Control power supply	+24 [V] DC, 0.2 [A]
CONT1 CONT2 CONT3 CONT4 CONT5 CONT6 CONT7 CONT8	21 22 1 2 3 4 23 24	Control input	+24 [V] DC, 10 [mA] Initially assigned at factory : CONT1 : RUN (run command) CONT2 : FWD (forward command) (*2) CONT3 : REV (reverse command) (*2) CONT4 : RST (alarm reset) CONT5 : START (auto start) CONT6 : ORG (origin return) CONT7 : X1 (multistep speed selection X1) CONT8 : —
OUT1 OUT2 OUT3 OUT4 OUT5	5 6 26 7 8	Control output	+30 [V] DC, 50 [mA] max. Initially assigned at factory : OUT1 : RDY (ready) OUT2 : CPURDY (CPU ready) OUT3 : Data error OUT4 : Address error OUT5 : —
P10 M5	11 13	Analog input power supply	Input for speed command and torque command +10 [V] DC, 200 [mA]
NREF	17	Speed command input	Input terminal for speed command voltage
MON1 MON2 M5	16 14 9	Monitor 1 Monitor 2 (output)	Analog voltage. Initially assigned at factory : MON1 : Speed monitor MON2 : Torque monitor
CA,*CA CB,*CB M5	35, 36 33, 34 25	Pulse train input	Input freq. : 500 [kHz] max. (differential input)
FA,*FA FB,*FB FZ,*FZ	31, 32 29, 30 27, 28	Freq. dividing output	Freq. dividing terminal. Two 90° phase-different signal is outputted, in proportion with rotational quantity of motor.
BAT+ BAT-	10 12	External backup (input)	Power supply for serial encoder backup
—	15	—	(unused)

(\*1) Each of terminal M5 is internally connected. They are not connected with terminal M24.

Note : (\*2)

Direction of motor shaft rotation (when viewed from a point facing the drive-end of motor) is designed according to Japanese standards:

- Forward direction : Counterclockwise (CCW) rotation
- Reverse direction : Clockwise (CW) rotation

**(2) SX bus type (SX bus direct connection)**

Host controller can be direct connected to an SX bus of MICREX-SX series. 16 word of the IQ area are reserved, and position control is executed on the amplifier side.

It is possible to extend an amplifier with one SX bus extension cable.

The IQ area of the CPU is of 512 word (at maximum).

RYS S3-LSS type amplifier connects an SX bus to CN3.

Control input/output signals are connected to CN1.

(a) CN3 (upper side)

An SX bus extension cable is connected to CN3. An SX bus loop-back plug is connected to the termination.

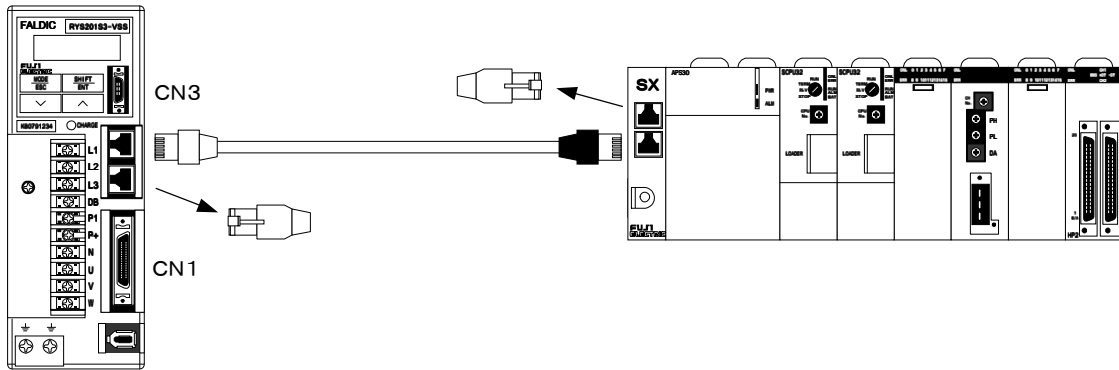

(b) CN1 (lower side)

Connect control input/output signals.

26	M 5	25	* C B	13	P 5	12	M 5
24	C B	23	* C A	11	MON 1	10	MON 2
22	C A	21	* F Z	9	M 2 4	8	P 2 4
20	F Z	19	* F B	7	OUT 2	6	OUT 1
18	F B	17	* F A	5	CONT 5	4	CONT 4
16	F A	15	B A T -	3	CONT 3	2	CONT 2
14	B A T +			1	CONT 1		

Plug : 10126-3000V  
Shell kit : 10326-52A0-008

External sensors such as origin LS are connected to the control input signal (CONTn).  
Control output signal (OUTn) is used in case signals are outputted from the amplifier.

(c) IQ area, 16 word (SX bus type)

• IQ area

Address	15	14	13	12	11	10	9	8	7	6	5	4	3	2	1	0
0	Current position, current deviation, basic para., system para. current position data/LS-Z phase pulse (Low order word PC Amplifier)															
1	Current position, current deviation, basic para., system para. current position data/LS-Z phase pulse (High order word PC Amplifier)															
2	Current speed, current speed data (Low order word PC ← Amplifier)															
3	Current speed, current speed data (High order word PC ← Amplifier)															
4	Current torque/current timer data (PC ← Amplifier)															
5	-					Alarm code, current status			Current M code							
6	-					CSEL 2	CSEL 1	CSEL 0	Para. No. current, current positioning data							
7	OUT 3	OUT 4	OUT 5	OUT 6	OUT 7	OUT 8	OUT 9	OUT 10	OUT 11	OUT 12	OUT 13	OUT 14	OUT 15	OUT 16	Rewrite end	Read end
8	Basic para., system para., position data (Low order word PC → Amplifier)															
9	Basic para., system para., position data (High order word PC → Amplifier)															
10	Speed command, speed data setting (Low order word PC → Amplifier)															
11	Speed command, speed data setting (High order word PC → Amplifier)															
12	Timer data setting															
13	-					Status setting			M code setting							
14	-					SEL2	SEL1	SEL0	Para. No. setting, positioning data setting							
15	CONT 6	CONT 7	CONT 8	CONT 9	CONT 10	CONT 11	CONT 12	CONT 13	CONT 14	CONT 15	CONT 16	CONT 17	CONT 18	CONT 19	Rewrite command	Read command

The data to read or to rewrite can be selected by on/off of SEL0, SEL1, SEL2 at bit 8 to 10 in word +14.

Read/rewrite data selection

SEL2	SEL1	SEL0	IQ area (Upper line : 0 to 7W, Lower line : 8 to 15W)
OFF	OFF	OFF	Current command position, current speed, current torque, current M code Position data setting, speed command/speed data setting
OFF	OFF	ON	Current feedback position, current speed, current torque, current M code Position data setting, speed command/speed data setting
OFF	ON	OFF	Current deviation, current speed, current torque, current M code Position data setting, speed command/speed data setting
OFF	ON	ON	- -
ON	OFF	OFF	Current basic para. Basic para. setting, speed command/speed data setting
ON	OFF	ON	Current system para. System para. setting, speed command/speed data setting
ON	ON	OFF	Current positioning data Positioning data setting
ON	ON	ON	Current pulse value between LS-Z phase Position data setting, speed command/speed data setting

(d) Terminal function  
CN1 (lower side)

Terminal symbol (*)	Connector pin No.	Terminal name	Function
P24 M24	8 9	Control power supply	+24 [V] DC, 0.2 [A]
CONT1 CONT2 CONT3 CONT4 CONT5	1 2 3 4 5	Control input	+24 [V] DC, 10 [mA] Initially assigned at factory : CONT1 : – (unassigned) CONT2 : – (unassigned) CONT3 : – (unassigned) CONT4 : – (unassigned) CONT5 : – (unassigned)
OUT1 OUT2	6 7	Control output	+30 [V] DC, 50 [mA] max. Initially assigned at factory : OUT1 : Brake timing OUT2 : Dynamic braking
MON1 MON2 M5	11 10 12	Monitor 1 Monitor 2 (output)	Analog voltage. Initially assigned at factory : MON1 : Speed monitor MON2 : Torque monitor
CA, *CA CB, *CB M5	22, 23 24, 25 26	Pulse train input	Input freq. : 500 [kHz] max. (differential input)
FA, *FA FB, *FB FZ, *FZ	16, 17 18, 19 20, 21	Freq. dividing output	Freq. dividing terminal. Two 90° phase-different signal is outputted, in proportion with rotational quantity of motor.
BAT+ BAT–	14 15	External backup (input)	Power supply for serial encoder backup

(\*) Each of terminal M5 is internally connected. They are not connected with terminal M24.

**(3) T-link type (T-link direct connection)**

Host controller can be direct connected to a T-link, that is a save-wiring I/O-link of MICREX-F series. 8 word of the WB area are reserved, and position control is executed on the amplifier side.

It is possible to extend an amplifier with one T-link extension cable.

The B area of the CPU is of 100 word (per line).

RYS S3-LTS type amplifier connects a T-link cable to CN3.

Control input/output signals are connected to CN1.

**(a) CN3 (upper side)**

The wiring of a T-link is of the method to connect the multiple devices in a "daisy-chain" style, and a terminating resistance is connected to its termination.

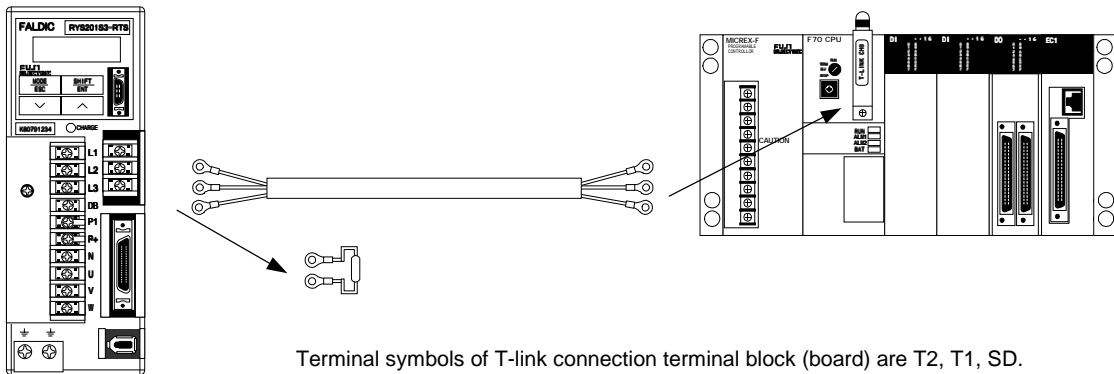

**(b) CN1 (lower side)**

26	M 5	25	P 5	13	M 5	12	C B
24	MON 2	23	* C B	11	C A	10	F Z
22	* C A	21	B A T +	9	F B	8	F A
20	O U T 4	19	O U T 3	7	O U T 2	6	O U T 1
18	C O N T 8	17	C O N T 7	5	C O N T 4	4	C O N T 3
16	C O N T 6	15	C O N T 5	3	C O N T 2	2	C O N T 1
14	M 2 4			1	P 2 4		

Plug : 10126-3000V  
Shell kit : 10326-52A0-008

External sensors such as origin LS are connected to the control input signal (CONTn).  
Control output signal (OUTn) is used in case signals are outputted from the amplifier.

(c) WB area, 8 word (T-link type)

Address	0	1	2	3	4	5	6	7	8	9	A	B	C	D	E	F
+0	OUT 5	OUT 6	OUT 7	OUT 8	OUT 9	OUT 10	OUT 11	OUT 12	OUT 13	OUT 14	OUT 15	OUT 16	OUT 17	OUT 18	OUT 19	OUT 20
+1	OUT 21	ALM4	ALM3	ALM2	ALM1	ALM0	Rewrite end	Read end	M code							
+2	Read data (High order word								PC ← Amplifier)							
+3	Read data (Low order word								PC ← Amplifier)							
+4	CONT 9	CONT 10	CONT 11	CONT 12	CONT 13	CONT 14	CONT 15	CONT 16	CONT 17	CONT 18	CONT 19	CONT 20	CONT 21	CONT 22	CONT 23	CONT 24
+5	CONT 25	Read/rewrite data select					Rewrite command	Read command	Address No.							
+6	Rewrite data (High order word								PC → Amplifier)							
+7	Rewrite data (Low order word								PC → Amplifier)							

The data to read or to rewrite can be selected by on/off of bit 1 to 5 in ward +5.

Read/rewrite data selection

+1	+2	+3	+4	+5	WB area (when reading)	WB area (when rewriting)
OFF	OFF	OFF	OFF	OFF	Current feedback position	-
OFF	OFF	OFF	OFF	ON	Feedback speed	-
OFF	OFF	OFF	ON	OFF	Torque command	-
OFF	OFF	OFF	ON	ON	Deviation amount	-
OFF	OFF	ON	OFF	OFF	LS-Z phase pulse	-
OFF	OFF	ON	OFF	ON	Status	Status
OFF	OFF	ON	ON	OFF	Position data	Position data
OFF	OFF	ON	ON	ON	Speed data	Speed data
OFF	ON	OFF	OFF	OFF	Timer data	Timer data
OFF	ON	OFF	OFF	ON	Basic para.	Basic para.
OFF	ON	OFF	ON	OFF	System para.	System para.
OFF	ON	OFF	ON	ON	-	-
OFF	ON	ON	OFF	OFF	-	-
OFF	ON	ON	OFF	ON	-	-
OFF	ON	ON	ON	OFF	Current command position	-
OFF	ON	ON	ON	ON	Command speed	-
ON	OFF	OFF	OFF	OFF	-	Speed command [FWD/REV]

## (d) Terminal function

## (i) CN1 (lower side)

Terminal symbol (*1)	Connector pin No.	Terminal name	Function
P24 M24	1 24	Control power supply	+24 [V] DC, 0.2 [A]
CONT1 CONT2 CONT3 CONT4 CONT5 CONT6 CONT7 CONT8	2 3 4 5 15 16 17 18	Control input	+24 [V] DC, 10 [mA] Initially assigned at factory : CONT1 :— (unassigned) CONT2 :— (unassigned) CONT3 :— (unassigned) CONT4 :— (unassigned) CONT5 :— (unassigned) CONT6 :— (unassigned) CONT7 :— (unassigned) CONT8 :— (unassigned)
OUT1 OUT2 OUT3 OUT4	6 7 19 20	Control output	+30 [V] DC, 50 [mA] max. OUT1 :— (unassigned) OUT2 :— (unassigned) OUT3 :— (unassigned) OUT4 :— (unassigned)
MON2 M5	24 26	Monitor 2 (output)	Analog voltage. Initially assigned at factory : MON2 : Torque monitor
P5 M5	25 13	Power supply for pulse train	+5 [V] DC, 200 [mA]
CA, *CA CB, *CB	11, 22 12, 23	Pulse train input	Input freq. : 500 [kHz] max. (differential input) (*2)
FA FB FZ	8 9 10	Freq. dividing output	Freq. dividing terminal. Two 90° phase-different signal is outputted, in proportion with rotational quantity of motor. (*2)
BAT+	21	External backup (input)	Power supply for serial encoder backup (*2)

(\*1) Each of terminal M5 is internally connected. They are not connected with terminal M24.

(\*2) Reference potential is at M5 terminal.

**(4) General-purpose communication (RS485)**

Connect RS485 cable to CN3 of RYS S3-LRS type amplifier.  
 Connect the control input/output signal to CN1.

• CN3 (upper side)

Use 8-pin (RJ-45) plug to connect CN3. Use the straight connection between slave units (FALDIC-

Use the cross connection between the master and slave unit (FALDIC-

1	2	3	4	5	6	7	8
TXD	*TXD	RXD	TER	*TER	*RXD	SG	SG

(Pin layout of front side of amplifier)

Straight cable		Cross cable	
Pin 1 (TXD)	Pin 1 (TXD)	Pin 1 (TXD)	Pin 3 (RXD)
Pin 2 (*TXD)	Pin 2 (*TXD)	Pin 2 (*TXD)	Pin 6 (*RXD)
Pin 3 (RXD)	Pin 3 (RXD)	Pin 3 (RXD)	Pin 1 (TXD)
Pin 6 (*RXD)	Pin 6 (*RXD)	Pin 4 (*RXD)	Pin 2 (*TXD)

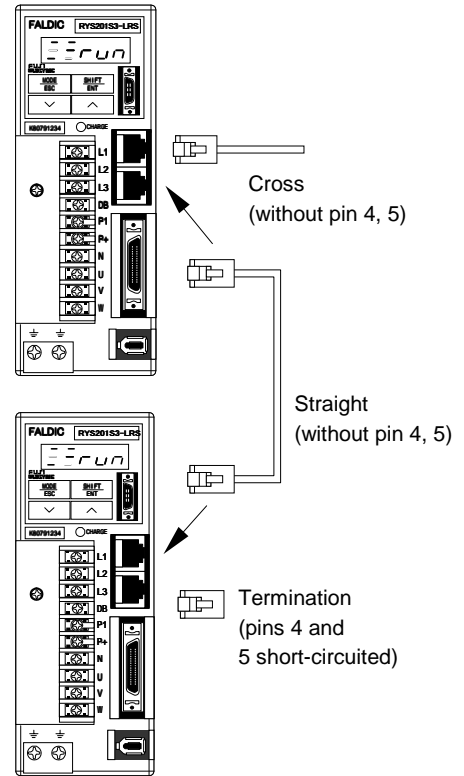

• CN1 (lower side)

Connect control input/output signals.

26	M 5	25	P 5	13	M 5	12	C B
24	MON 2	23	* C B	11	C A	10	F Z
22	* C A	21	B A T +	9	F B	8	F A
20	OUT 4	19	OUT 3	7	OUT 2	6	OUT 1
18	CONT 8	17	CONT 7	5	CONT 4	4	CONT 3
16	CONT 6	15	CONT 5	3	CONT 2	2	CONT 1
14	M 2 4			1	P 2 4		

Plug: 10126-3000V  
 Shell kit: 10326-52A0-008  
 Sumitomo-3M make  
 The connector maker may be changed.

Communication specification

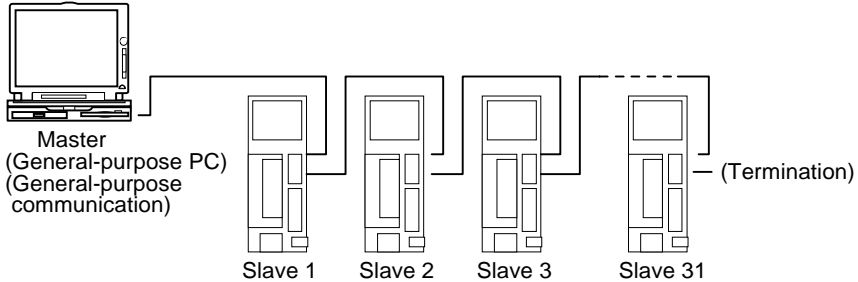
Item	Specifications
Signal level	RS485
Synchronization method	Start-stop synchronization
Communication method	4-wire half-duplex
Transmission rate	9600, 19200, 38400 [bps] (setting by system para. 97)
Data length	8 bits
Transmission configuration	Start bit: 1 bit, data bit: 8 bits, parity bit: 1 bit (even), stop bit: 1 bit
Transmission control	Permeability mode (No distinction by DLE character)
Error check	Check sum
Transmission length	Receiving 40 bytes, transmitting 40 bytes (max.)
Communication form	<p>1 : n communication (1 n 31)</p> <p>Amplifier operates as a slave and can respond commands sent from the master. Communication between slaves are not performed.</p> 
Station number	1 to 31 (setting by system para. 97)
Response time	<p>Operation command: 5 [ms] or less</p> <p>Data (parameter) transfer: 20 [ms] or less</p> <p>(Response time can be fixed by system para. 91 setting.)</p>

Note: Some software cannot have the stop bit if 8 bits are specified to data bit.

Transmission format

(1) Data read out from amplifier

Data inside the amplifier is sent back according to the message from the master.

If read out is possible, ACK and data are sent back, if not, NAK is sent back.

- Read out from amplifier

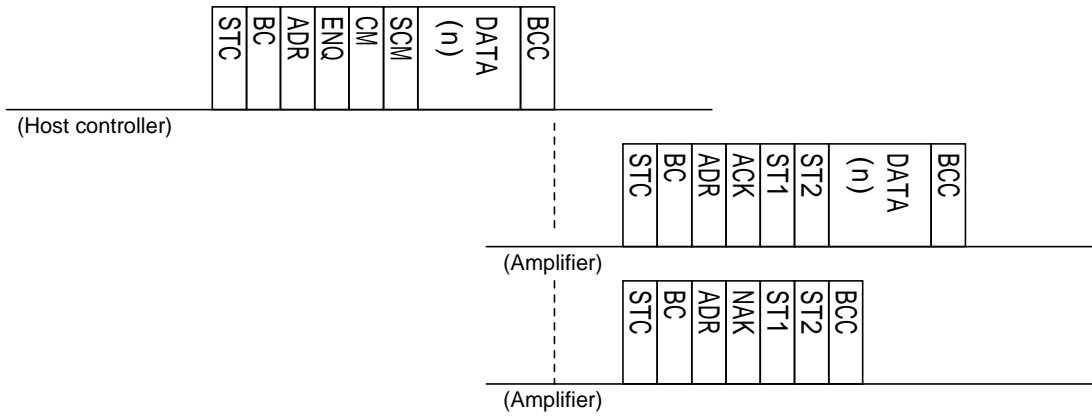

(2) Data write and operation command to amplifier

Data inside the amplifier can be rewritten according to the message from the master.

Operation commands such as manual forward operation and origin return can be given to the amplifier.

If execution is enable, ACK is sent back, and if not, NAK is sent back.

- Data write and operation command to amplifier

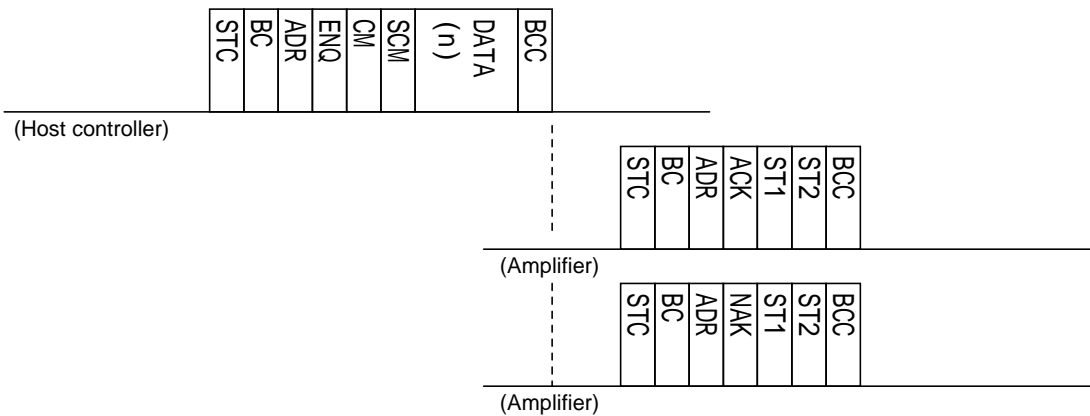

Transmission code

Code	Contents (HEX)	Function
STC	A5H (fixed)	Top code
BC	xxH (variable)	Byte counter The number of bytes from ADR to BCC can be set.
ADR	01H to 1FH	Station number The station number of 1 through 31 which identifies amplifiers can be set.
ENQ	05H (fixed)	Enquiry (request)
ACK	06H (fixed)	Acknowledgment (affirmative response)
NAK	15H (fixed)	Negative acknowledgment (negative response)
CM	xxH (variable)	Command The command (instruction) to amplifier is specified.
SCM	xxH (variable)	Sub-command Details of command (instruction) are specified.
DATA (n)	xxH (variable)	Data Data attached to command
ST1	xxH (variable)	Status 1 Data of transmission system is expressed in 8 bits.
ST2	xxH (variable)	Status 2 The on/off of control output signal is expressed in 8 bits.
BCC	xxH (variable)	Check sum The lower 8 bits including the contents from STC to immediate before BCC.

ST1 (transmission system)

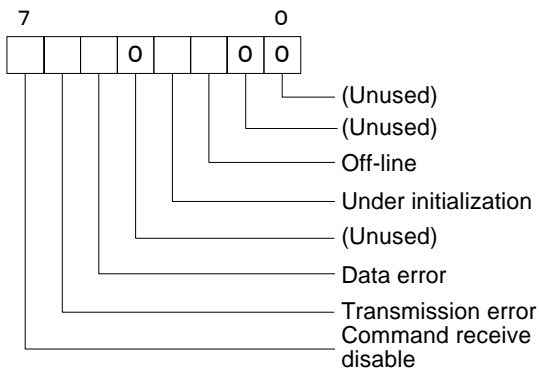

ST2 (control output signal)

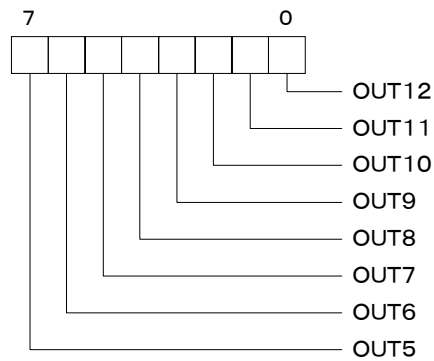

ST1 (transmission system details)

Command receive disable (bit 7)

Where edit and initialization have been executed while parameters (positioning data) are write-protected.

It is in off-line state and the command of PC loader has priority.

Transmission error (bit 6)

Parity unmatching, framing error (mistake in stop bit length)

Data error (bit 5)

Wrong command configuration, BCC unmatching, beyond setting range

Under initialization (bit 3)

Under initializing parameters and positioning data

Off-line (bit 2)

It is in off-line state and the command of PC loader has priority.

CN1 (lower side) terminal function

Terminal symbol	Connector pin No.	Terminal name	Function
P24 M24	1 24	Power input for control input	Power input for control input/output signal (+24 [V] DC, 0.2 [A])
CONT1 CONT2 CONT3 CONT4 CONT5 CONT6 CONT7 CONT8	2 3 4 5 15 16 17 18	Control input	Control input signal. At factory shipment, the following signals have been allocated. (+24 [V] DC, 10 [mA]) CONT1: Run command [RUN] CONT2: Auto start [START] CONT3: Origin LS [LS] CONT4: +OT CONT5: -OT CONT6: Forced stop [EMG] CONT7: - CONT8: -
OUT1 OUT2 OUT3 OUT4	6 7 19 20	Control output	Control output signal. At factory shipment, the following signals have been allocated. (+30 [V] DC max., 50 [mA]) OUT1: Ready [RDY] OUT2: Positioning end [PSET] OUT3: - OUT4: -
MON2 M5	24 26	Monitor output 2	Analog voltage output. At factory shipment, the following signal has been allocated. MON2: Torque monitor
P5 M5	25 13	Power output for pulse train	Power output terminal of pulse train (+5 [V] DC, 200 [mA])
CA, *CA CB, *CB	11, 23 12, 23	Pulse train input	Input terminal of pulse train (max. input frequency 500kHz [differential input]) (Reference potential is at terminal M5.)
FA FB FZ	8 9 10	Freq. dividing output	Freq. dividing output terminal. Two 90 ° phase-differential signal in proportion to motor rotational quantity is output. (Reference potential is at terminal M5.)
BAT+	21	External backup power	Backup power for serial encoder (Reference potential is at terminal M5.)

Note: Each of terminal M5 is internally connected each other. They are not connected to terminal M24.

Command list

Command

CM	SCM	DATA(n)		Function
		ENQ	ACK/NAK	
30H	30H	(2)	(6 to 18)	Reading out of monitored data
	31H	-	(15)	Reading out of the positioning data under execution
31H	30H	-	(3)	Reading out of sequence mode
	31H	-	(2)	Reading out of control input/output signal
	32H	-	(9)	Reading out of alarm detection history
	33H	-	(1)	Reading out of alarm detection contents
32H	30H	(2)	(4 to 16)	Reading out of basic para.
	31H	(2)	(4 to 16)	Reading out of system para.
	32H	(6 to 18)	-	Writing of basic para.
	33H	(6 to 18)	-	Writing of system para.
33H	30H	(2)	(12 to 24)	Reading out of positioning data
	31H	(14 to 25)	-	Writing of positioning data

Command

CM	SCM	DATA (n)		Function
		ENQ	ACK/NAK	
34H	30H	-	-	Run command [RUN] off
	31H	-	-	Run command [RUN] on
	32H	(3)	-	Forward operation (immediate) on (DATA (n): specified speed value)
	33H	(1)	-	Forward operation (multistep speed) on (DATA (n): speed selection)
	34H	(3)	-	Reverse operation (immediate) on (DATA (n): specified speed value)
	35H	(1)	-	Reverse operation (multistep speed) on (DATA (n): speed selection)
	36H	-	-	Forward/reverse operation off (33H to 35H: cancel)
	37H	(6)	-	Setting of positioning data (immediate)
	38H	(1)	-	Setting of positioning data number
	39H	(6)	-	Auto start (immediate)
	3AH	(1)	-	Auto start (positioning data number)
	3BH	-	-	Origin return
	3CH	-	-	Release of forced stop
	3DH	-	-	Forced stop command
	3EH	-	-	Alarm reset
	3FH	(1)	-	Accel./decel. time selection (DATA (n): time selection)
	40H	-	-	Position preset
	41H	-	-	Pulse train ratio 1 off
	42H	-	-	Pulse train ratio 1 on
	43H	-	-	Pulse train ratio 2 off
	44H	-	-	Pulse train ratio 2 on
	45H	-	-	P-action off
	46H	-	-	P-action on
	47H	-	-	Current limiting off
	48H	-	-	Current limiting on
	49H	-	-	Temporary stop off
	4AH	-	-	Temporary stop on
	4BH	-	-	Positioning cancel (auto start, origin return)
	4CH	(1)	-	Teaching (Data (n): positioning data)
	4DH	-	-	Override off
	4EH	-	-	Override on
	4FH	(2)	-	Override scale factor selection (DATA (n): type and selection)
	50H	-	-	Interrupt valid off
	51H	-	-	Interrupt valid on
52H	-	-	Deviation clear off	
53H	-	-	Deviation clear on	
54H	-	-	Free-run off	
55H	-	-	Free-run on	
56H	-	-	Edit permit command off	
57H	-	-	Edit permit command on	
58H	-	-	Positive direction skip feed	
59H	-	-	Negative direction skip feed	
5AH	-	-	Alarm detection history initialization	
5BH	-	-	Status information	

(e) Interface circuits

Signal name	Specification	Interface circuit
Control input	+24 [V] DC, 10 [mA] (each one - point)	
Control output	+30 [V] DC, 50 [mA] (max.)	
Analog input	20 [k ] impedance	
Analog output (monitor output)	Voltage output	
Pulse train input	Differential input	
Pulse train output	Differential output	

#### 4.5 External connection diagrams (normal, example)

##### (1) External connection diagrams of RYS-S3-L \* S type amplifier and GYC, GYS type motor

	Page
(a) Basic type : 0.2 [kW] and below, DI/DO position	4-27
(b) Basic type : 0.4 and 0.75 [kW], DI/DO position	4-28
(c) Basic type : 1 and 1.5 [kW], DI/DO position	4-29
(d) Basic type : 2 to 5 [kW], DI/DO position	4-30
(e) Basic type : 0.05 and 0.1 [kW] for 100 [V] class input voltage of amplifier, DI/DO position	4-31
(f) Basic type : 0.2 [kW] for 100 [V] class input voltage of amplifier, DI/DO position	4-32
(g) Motor with providing brake	4-33
(h) SX bus type : 0.2 [kW] and below	4-34
(i) SX bus type : 0.4 and 0.75 [kW]	4-36
(j) SX bus type : 1 and 1.5 [kW]	4-37
(k) SX bus type : 2 to 5 [kW]	4-38
(l) SX bus type : 0.05 and 0.1 [kW] for 100 [V] class input voltage of amplifier	4-39
(m) SX bus type : 0.2 [kW] for 100 [V] class input voltage of amplifier	4-40
(n) T-link type : 0.2 [kW] and below	4-41
(o) T-link type : 0.4 and 0.75 [kW]	4-43
(p) T-link type : 1 and 1.5 [kW]	4-44
(q) T-link type : 2 to 5 [kW]	4-45
(r) T-link type : 0.05 and 0.1 [kW] for 100 [V] class input voltage of amplifier	4-46
(s) T-link type : 0.2 [kW] for 100 [V] class input voltage of amplifier	4-47
(t) RS485 interface: 0.2 [kW] and below	4-48
(u) RS485 interface: 0.4 and 0.75 [kW]	4-49
(v) RS485 interface: 1 and 1.5 [kW]	4-50
(w) RS485 interface: 2 to 5 [kW]	4-51
(x) RS485 interface: 0.05 and 0.1 [kW] for 100 [V] class input voltage of amplifier	4-52
(y) RS485 interface: 0.2 [kW] for 100 [V] class input voltage of amplifier	4-53

##### (2) External connection diagrams of RYS-V type amplifier and GYC type motor

(a) Positioning unit : AD75	4-54
(b) Position control unit : C200HW-NC113	4-55

(a) Basic type : 0.2 [kW] and below, DI/DO position

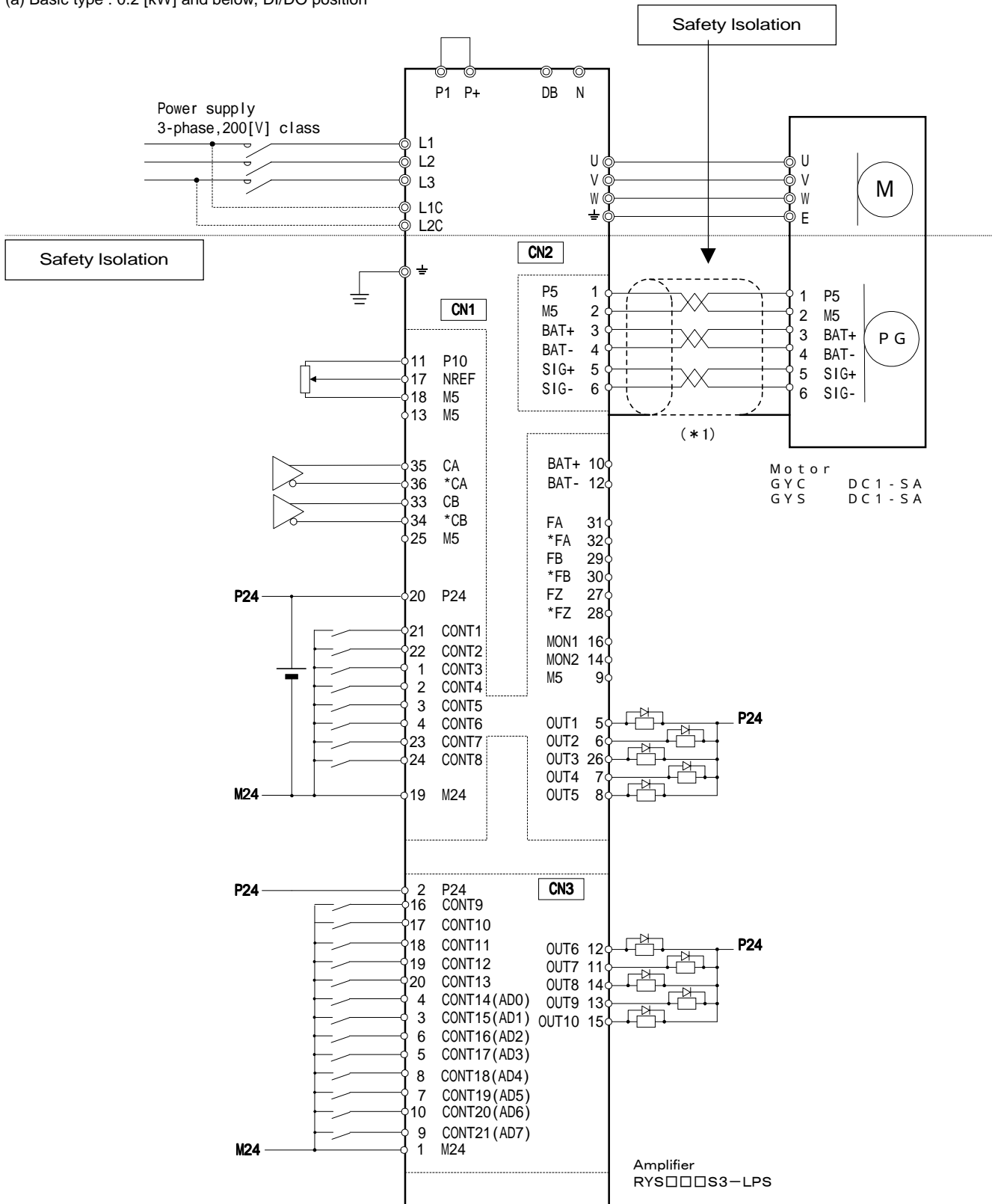

(\*1) Shielded sheath on the shielded cables must be connected with the shell body and the shell cover.

- CONT and OUT terminals are assigned at factory : See (1) (c) of 4.4 Host interface (I/F).
- The unit can be operate, even if no wiring is made to control power supply terminals L1C, L2C.

(b) Basic type : 0.4 and 0.75 [kW], DI/DO position

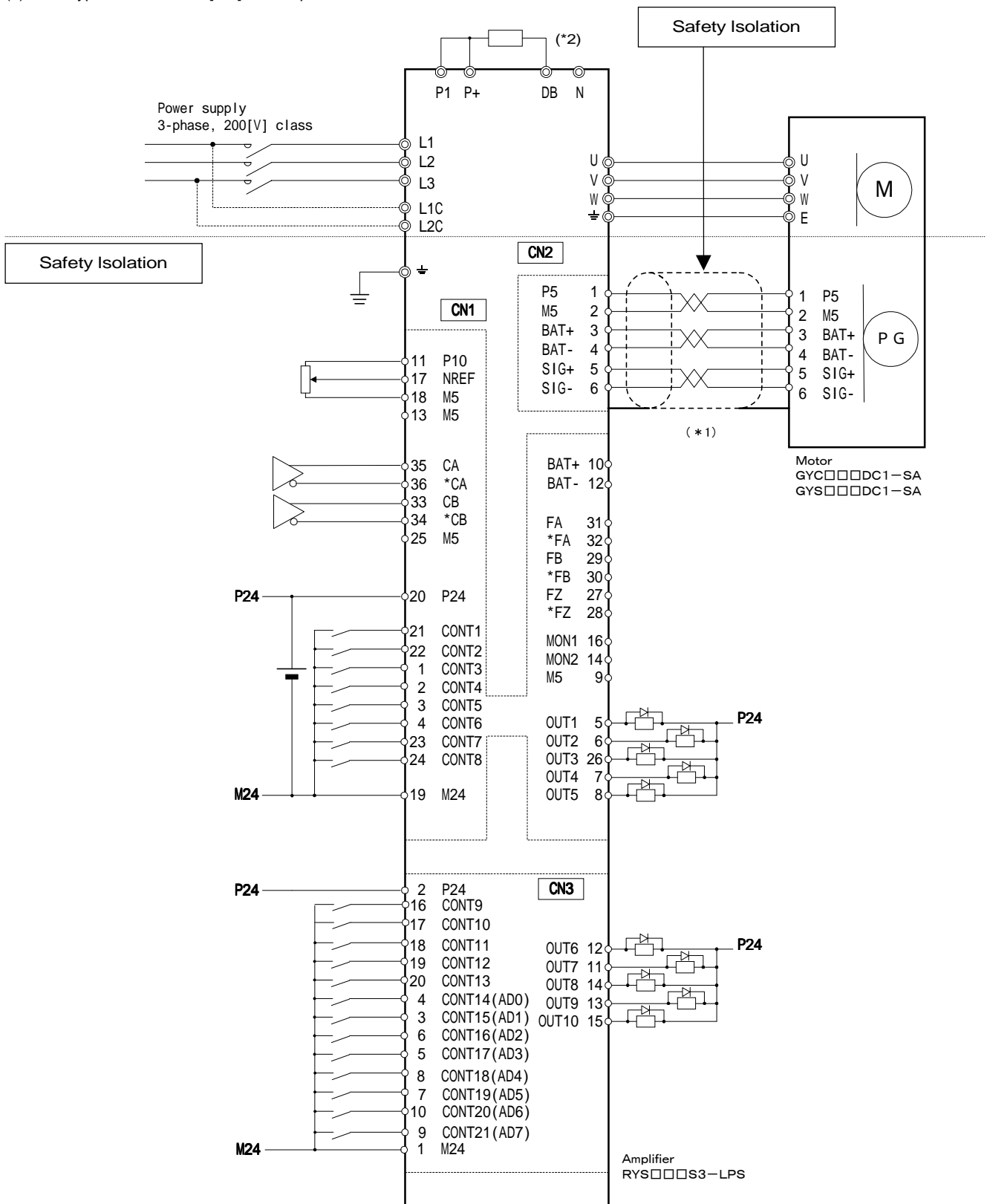

(c) Basic type : 1 and 1.5 [kW], DI/DO position

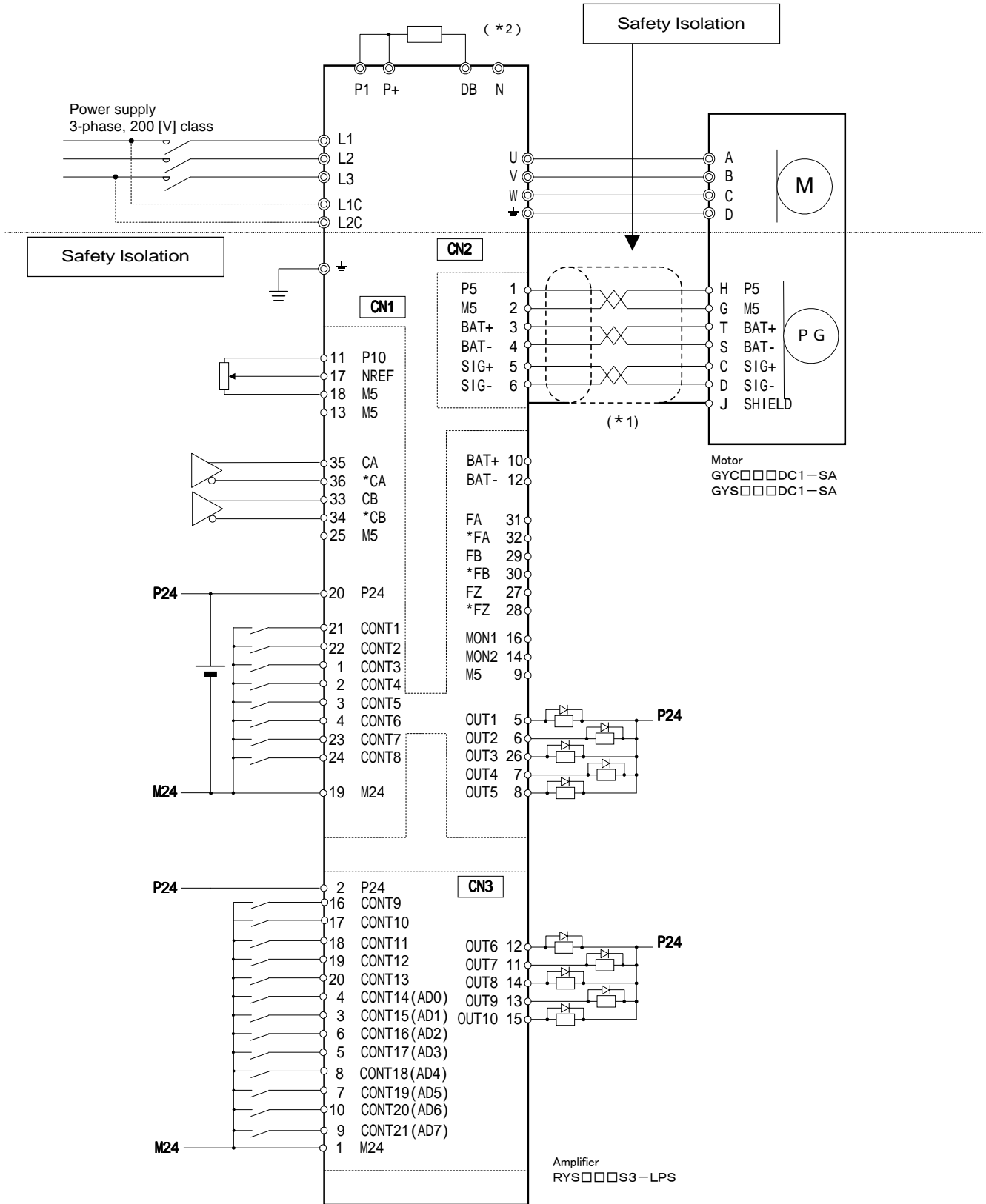

(\*1) Shielded sheath on the shielded cables must be connected with the J terminal and the shell cover.

(\*2) A braking resistor is provided (built-in) with amplifier.

(d) Basic type : 2 to 5 [kW], DI/DO position

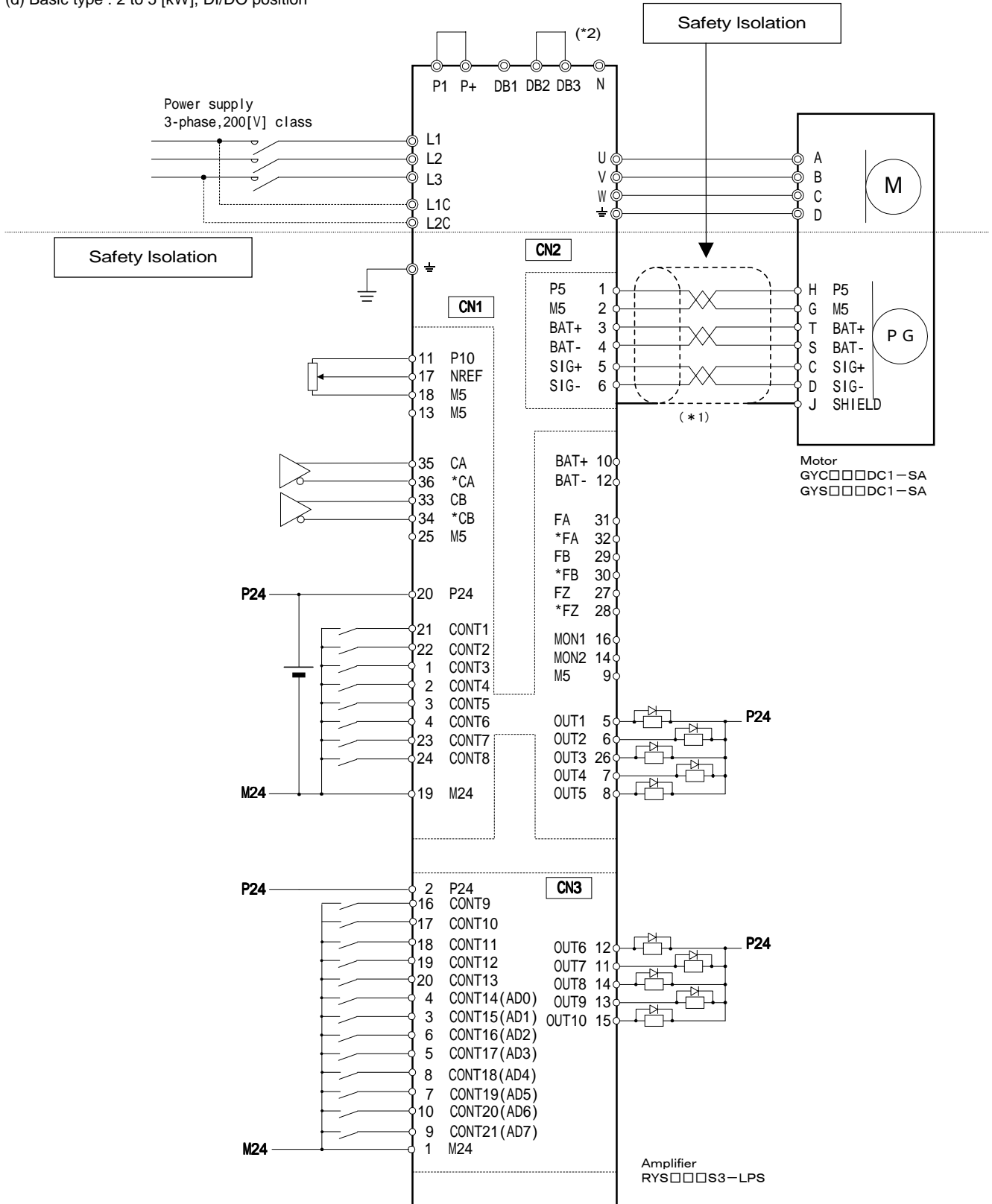

(\*1) Shielded sheath on the shielded cables must be connected with the J terminal and the shell cover.

(\*2) A braking resistor is provided (built-in) with amplifier.

(e) Basic type : 0.05 and 0.1 [kW] for 100 [V] class input voltage of amplifier, DI/DO position

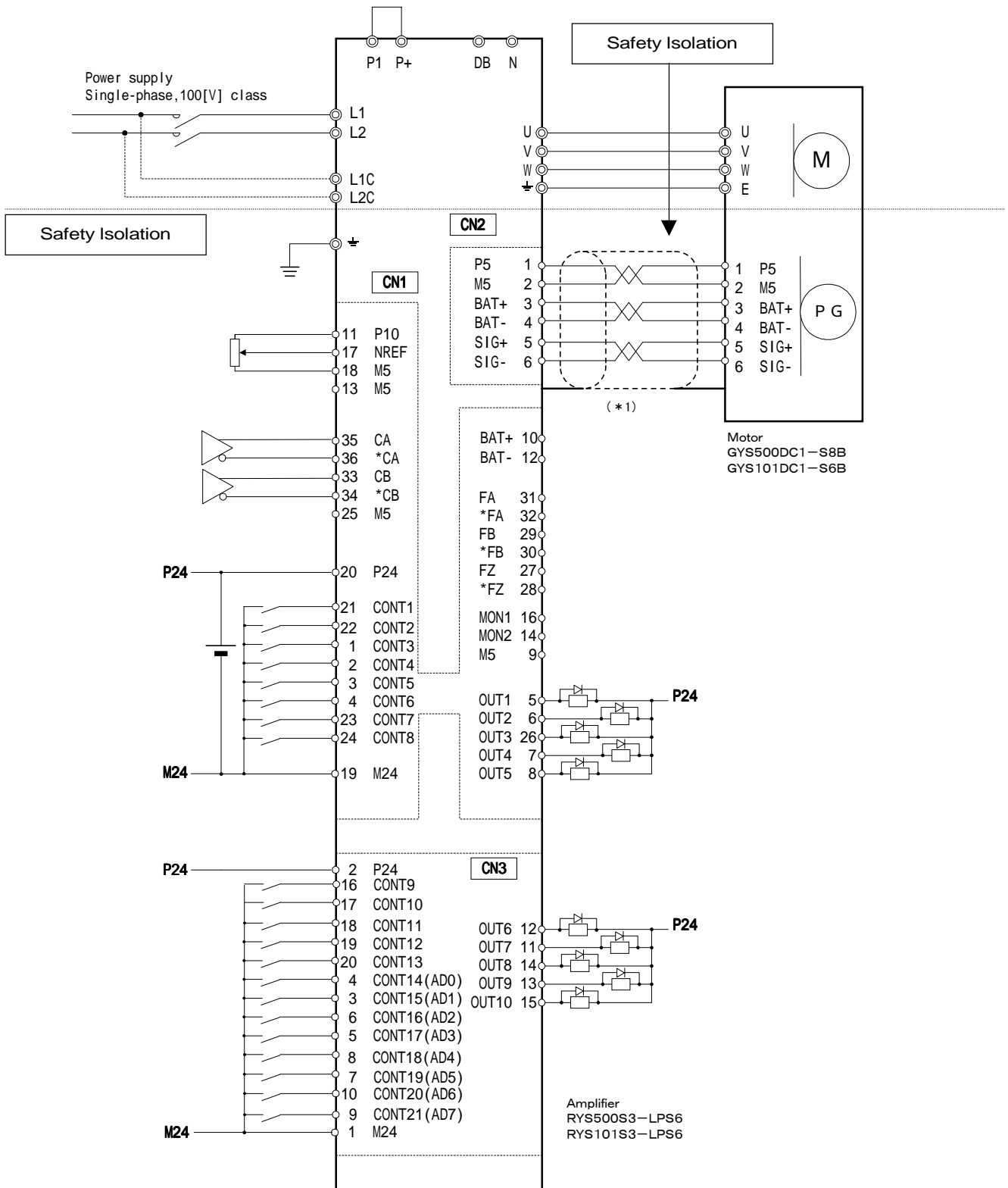

(\*) Shielded sheath on the shielded cables must be connected with the shell body and the shell cover.

(f) Basic type : 0.2 [kW] for 100 [V] class input voltage of amplifier, DI/DO position

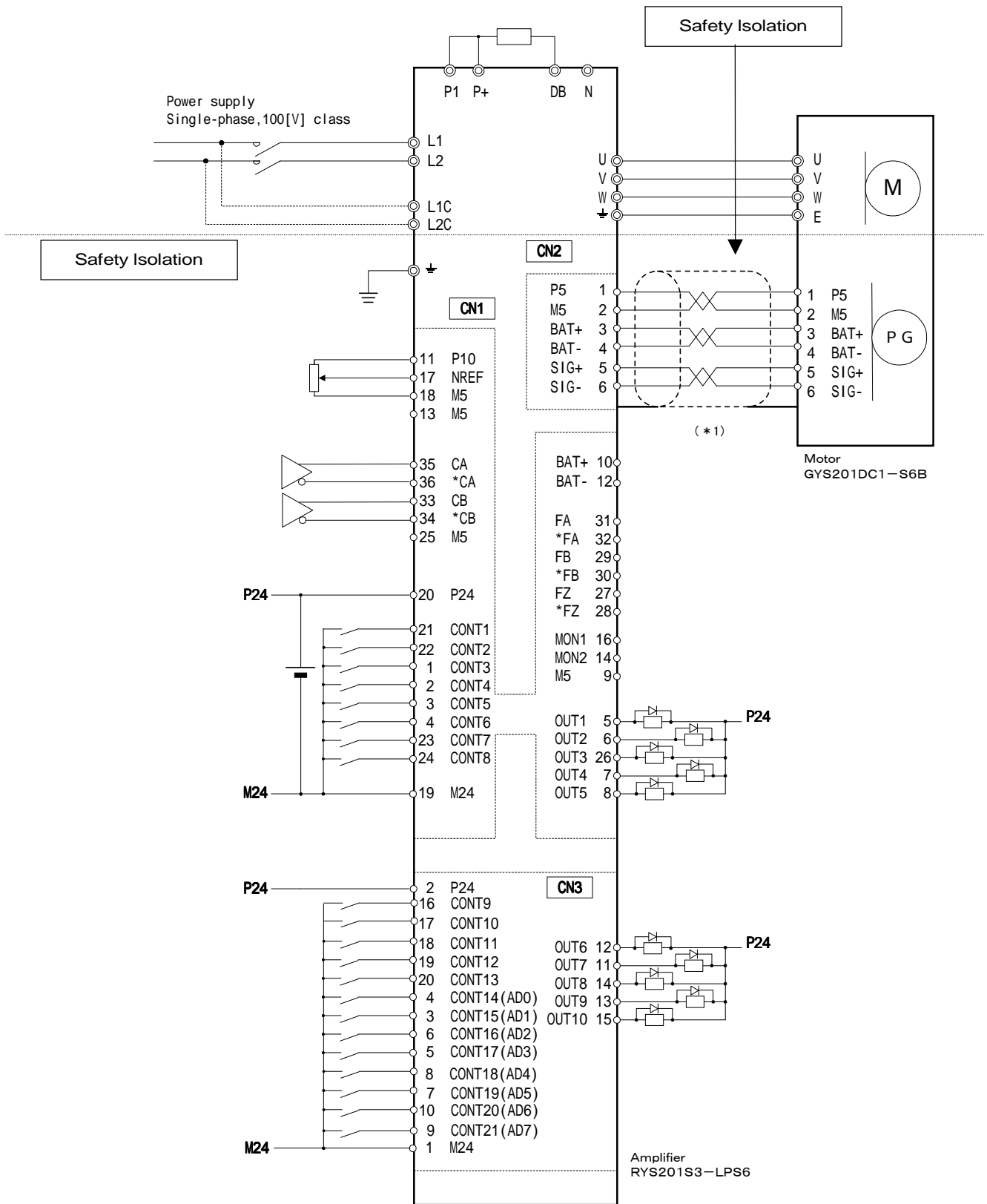

(\*1) Shielded sheath on the shielded cables must be connected with the shell body and the shell cover.

- (g) Motor with providing brake
- (i) 0.75 [kW] and below

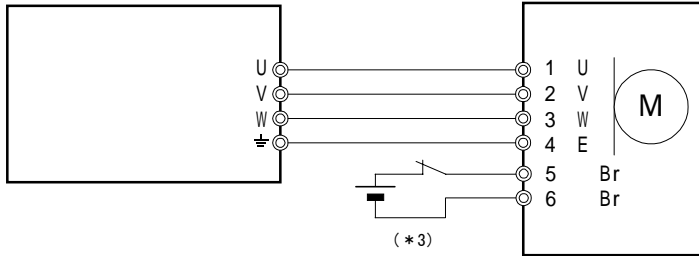

Motor type	GYC		GYS		GYC, GYS	
Rated output [kW]	0.1	0.2	0.1 and below	0.2	0.4	0.75
(*3) Brake power supply	24 [V] DC					
Brake input [W]	6.5	9	6.1	7.3	9	8.5

- (ii) 1 to 2 [kW]

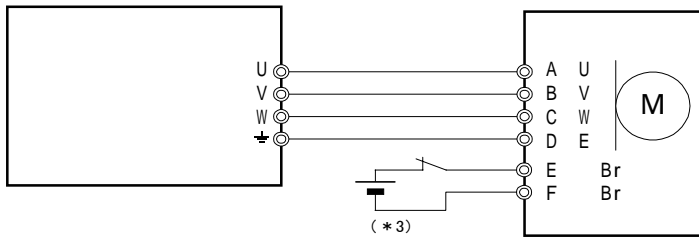

Motor type	GYC, GYS		
Rated output [kW]	1	1.5	2
(*3) Brake power supply	24 [V] DC		
Brake input [W]	12		

(h) SX bus type : 0.2 [kW] and below

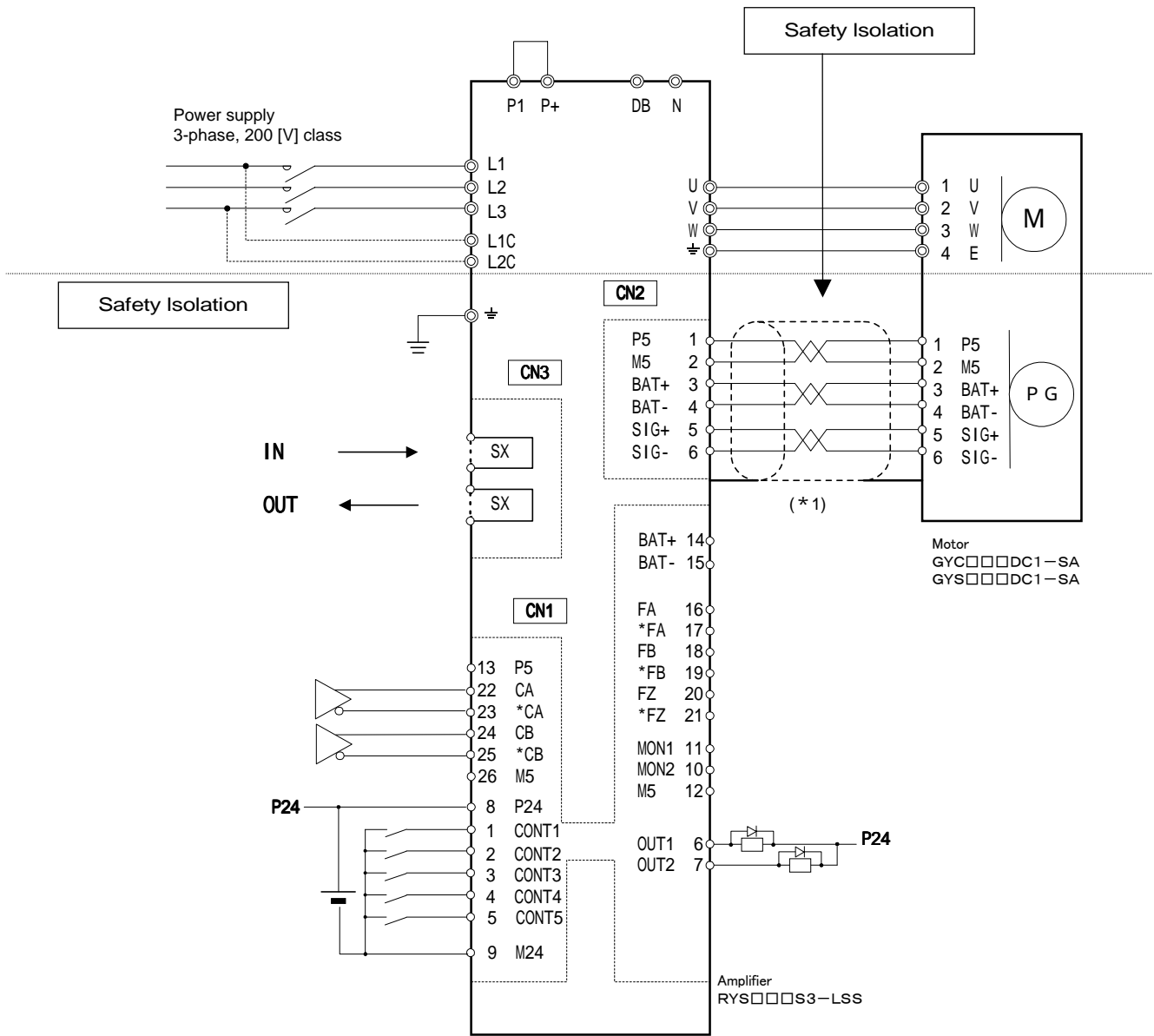

(\*1) Shielded sheath on the shielded cables must be connected with the shell body and the shell cover.

• CONT and OUT terminals are assigned at factory :

Terminal symbol	CONT1 to CONT5	OUT1	OUT2
Function	-	Brake timing	Dynamic braking

Initial factory setting value of IQ area is as follows : See 5.8 IQ area (SX bus type).

Address	15	14	13	12	11	10	9	8	7	6	5	4	3	2	1	0	
0	Current position, current deviation, basic para., system para. current position data/LS-Z phase pulse (Low order word PC Amplifier)																
1	Current position, current deviation, basic para., system para. current position data/LS-Z phase pulse (High order word PC Amplifier)																
2	Current speed, current speed data (Low order word PC ← Amplifier)																
3	Current speed, current speed data (High order word PC ← Amplifier)																
4	Current torque/current timer data (PC ← Amplifier)																
5	-				Alarm code, current status				Current M code								
6	-						CSEL 2	CSEL 1	CSEL 0	Para. No. current, current positioning data							
7	RDY	PSET	CPU ready	ALM	Data error	Address error	-	-	-	-	-	-	-	-	Rewrite end	Read end	
8	Basic para., system para., position data (Low order word PC → Amplifier)																
9	Basic para., system para., position data (High order word PC → Amplifier)																
10	Speed command, speed data setting (Low order word PC → Amplifier)																
11	Speed command, speed data setting (High order word PC → Amplifier)																
12	Timer data setting (PC → Amplifier)																
13	-				Status setting				M code setting								
14	-						SEL2	SEL1	SEL0	Para. No. setting, positioning data setting							
15	RUN	FWD	REV	RST	START	ORG	X1	VEL0	VEL1	ABC INC	-	-	-	-	Rewrite command	Read command	

The unit can be operated, even if no wiring is made to control power supply terminals L1C, L2C.

(i) SX bus type : 0.4 and 0.75 [kW]

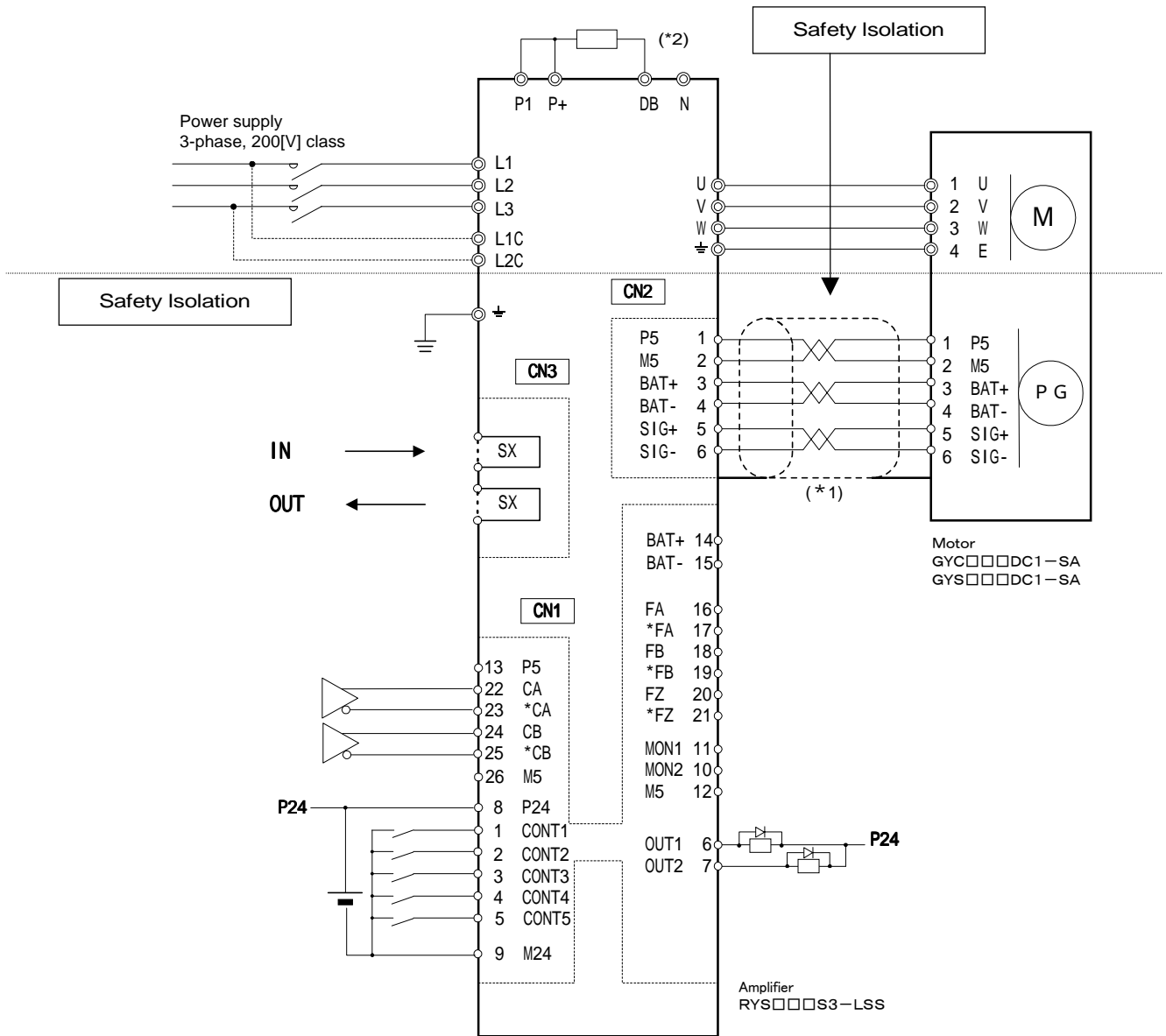

(\*1) Shielded sheath on the shielded cables must be connected with the shell body and the shell cover.

(\*2) A braking resistor is provided (built-in) with amplifier.

(j) SX bus type : 1 and 1.5 [kW]

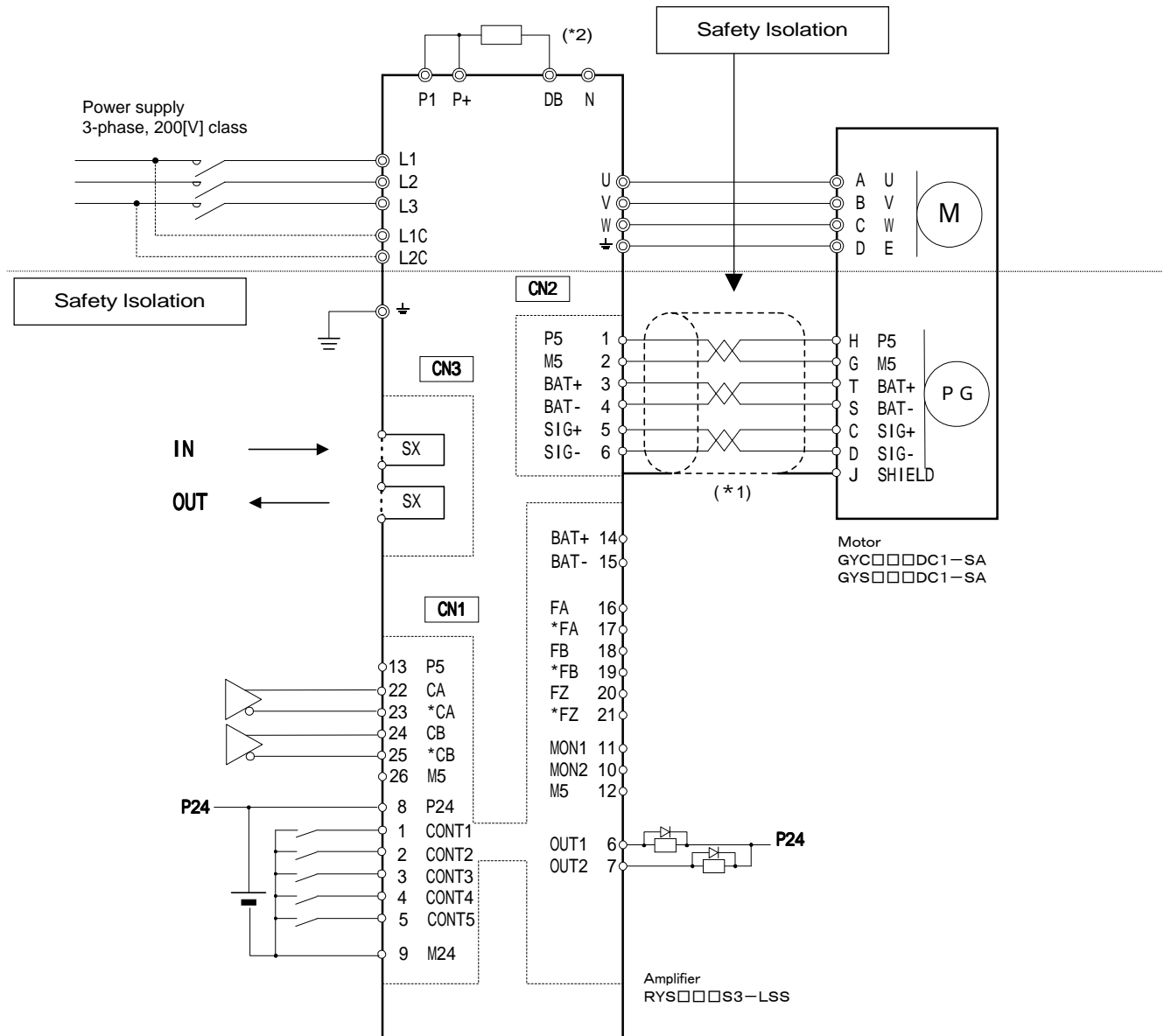

(\*1) Shielded sheath on the shielded cables must be connected with the J terminal and the shell cover.

(\*2) A braking resistor is provided (built-in) with amplifier.

(k) SX bus type : 2 to 5 [kW]

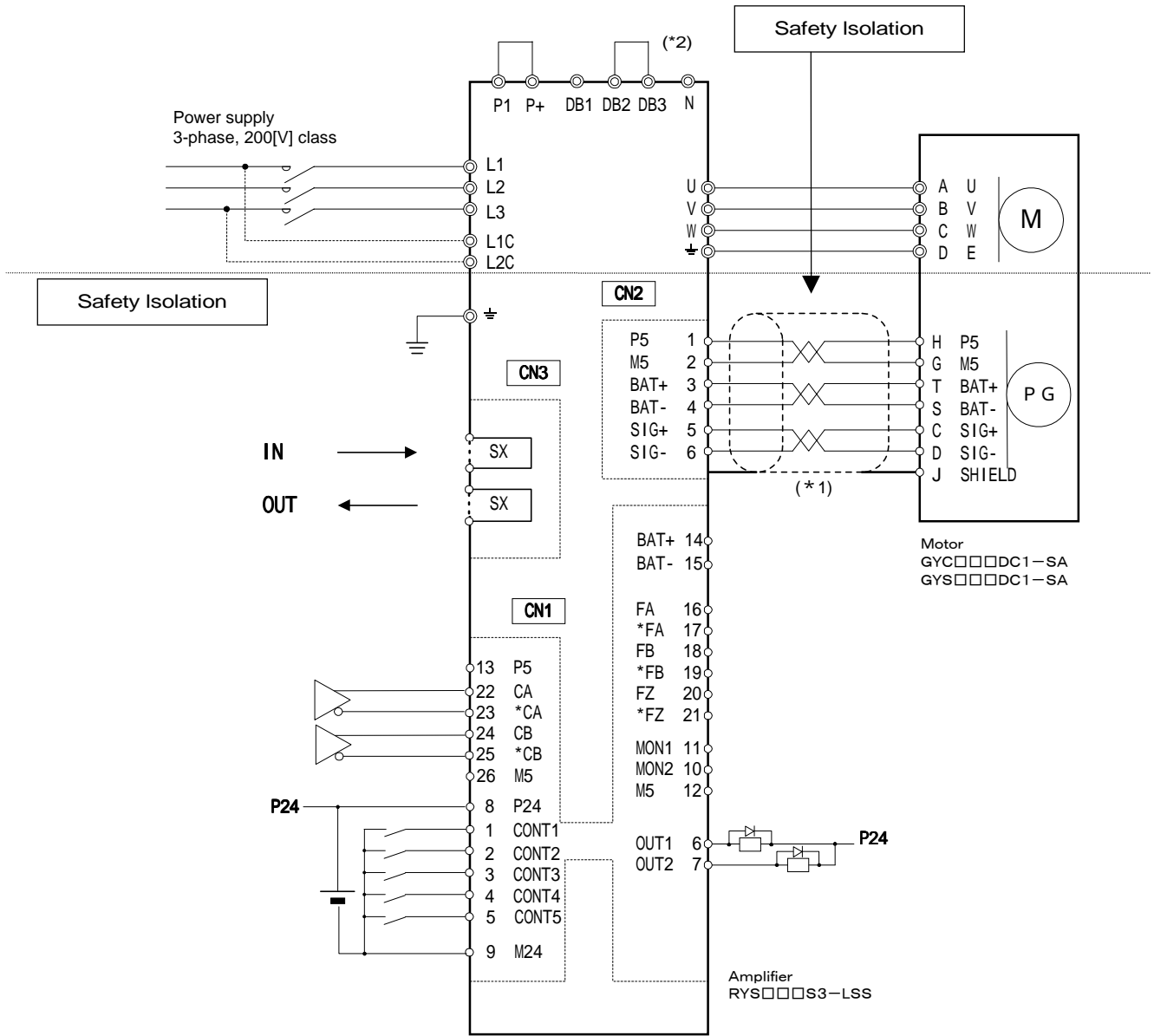

(\*1) Shielded sheath on the shielded cables must be connected with the J terminal and the shell cover.

(\*2) A braking resistor is provided (built-in) with amplifier.

(I) SX bus type : 0.05 and 0.1 [kW] for 100 [V] class input voltage of amplifier

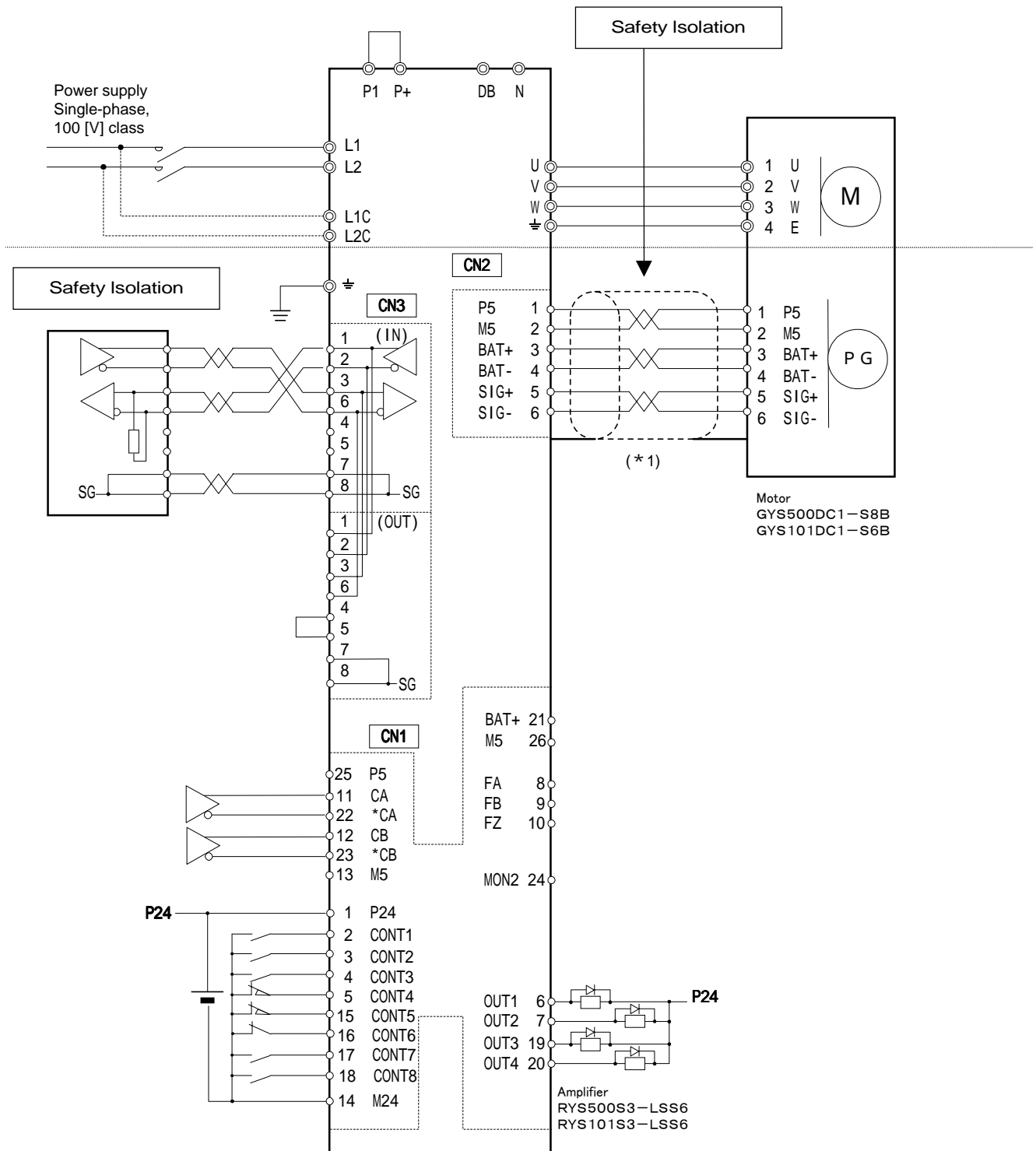

(\*1) Shielded sheath on the shielded cables must be connected with the shell body and the shell cover.

(m) SX bus type : 0.2 [kW] for 100 [V] class input voltage of amplifier

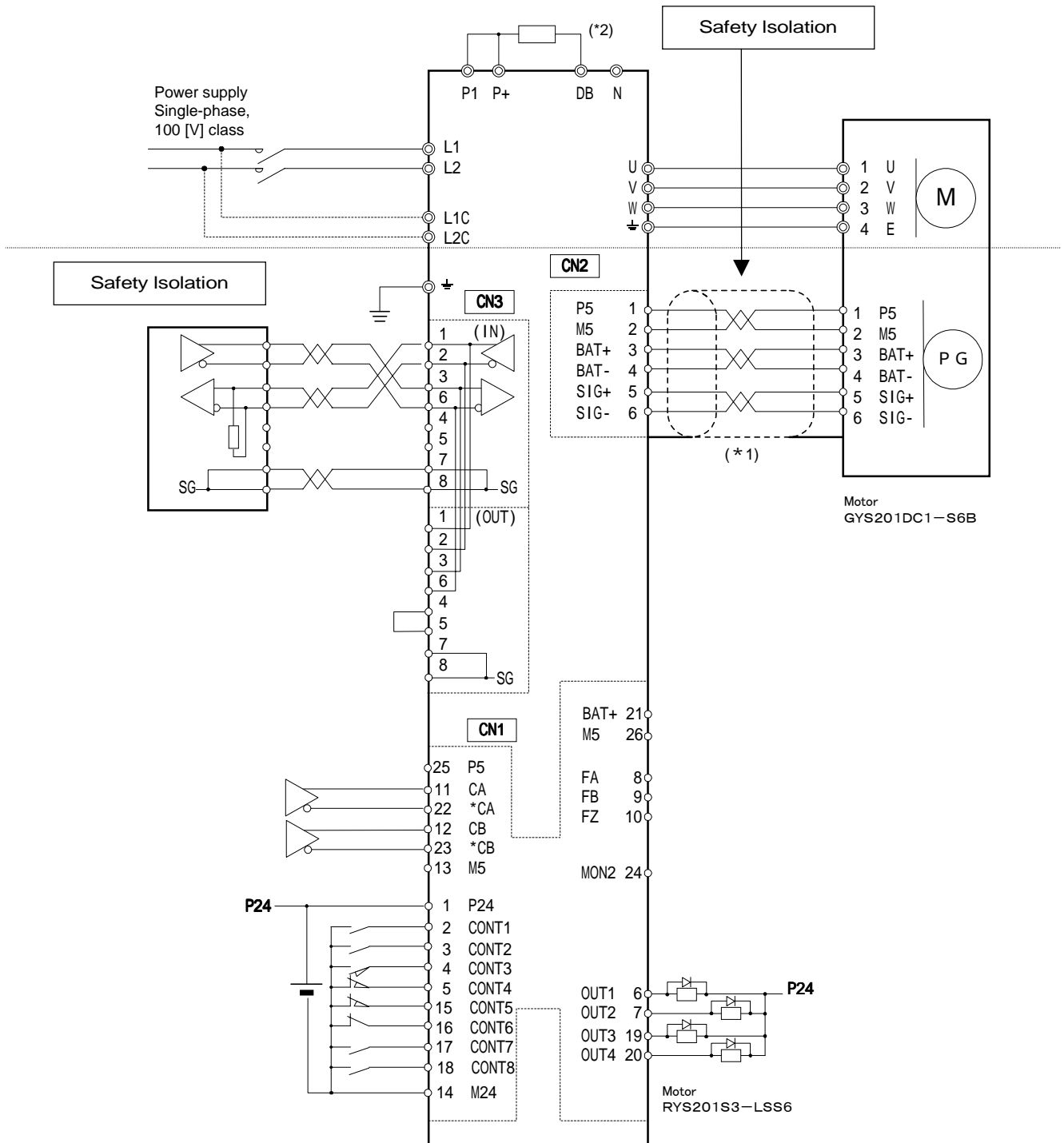

(\*1) Shielded sheath on the shielded cables must be connected with the shell body and the shell cover.

(\*2) A braking resistor is provided (built-in) with amplifier.

(n) T-link type : 0.2 [kW] and below

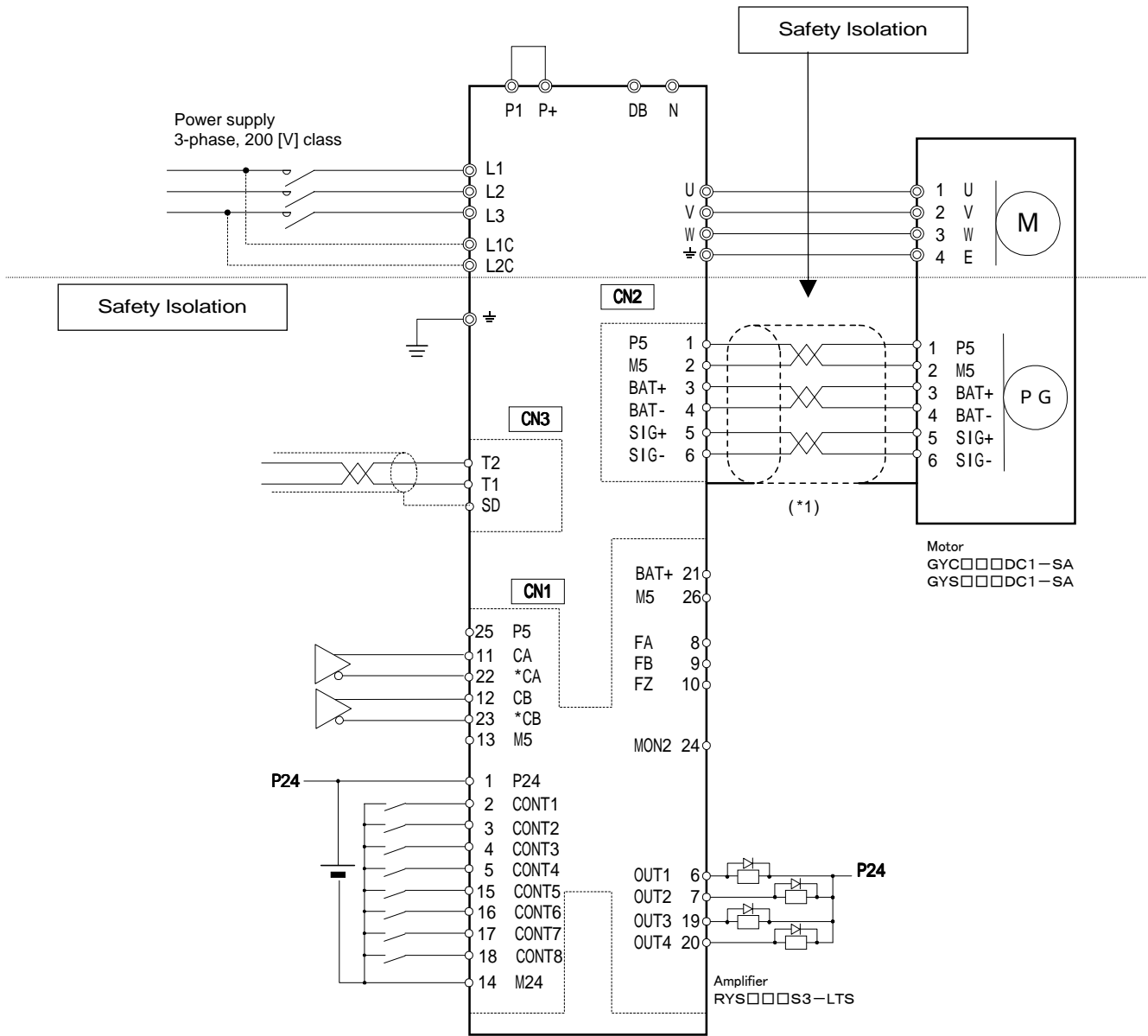

(\*1) Shielded sheath on the shielded cables must be connected with the shell body and the shell cover.

• CONT and OUT terminals are assigned at factory :

Terminal symbol	CONT1 to CONT8	OUT1 to OUT5
Function	-	-

Initial factory setting value of WB area is as follow : See 5.9 WB area (T-link type)

Address	0	1	2	3	4	5	6	7	8	9	A	B	C	D	E	F	
+0	RDY	PSET	CPU ready	Alarm detect	Address error	+OT detect	-OT detect	LS detect	EMG detect	Data error	-	-	-	-	-	-	
+1	-	Alarm code					Rewrite end	Read end	0	0	0	0	0	0	0	0	0
+2	Read data (High order word PC ← Amplifier)																
+3	Read data (Low order word PC ← Amplifier)																
+4	RUN	START	FWD	REV	ORG	EMG	RST	VELO	VEL1	ABS INC	X1	-	-	-	-	-	
+5	-	Read/rewrite data select					Rewrite command	Read command	Address No.								
+6	Rewrite data (High order word PC → Amplifier)																
+7	Rewrite data (Low order word PC → Amplifier)																

Read/rewrite data selection

+1	+2	+3	+4	+5	WB area (when reading)	WB area (when rewriting)
OFF	OFF	OFF	OFF	OFF	Current position	-
OFF	OFF	OFF	OFF	ON	Current speed	-
OFF	OFF	OFF	ON	OFF	Current torque	-
OFF	OFF	OFF	ON	ON	Current deviation	-
OFF	OFF	ON	OFF	OFF	Current LS-Z phase pulse	-
OFF	OFF	ON	OFF	ON	-	-
OFF	OFF	ON	ON	OFF	-	-
OFF	OFF	ON	ON	ON	-	-
OFF	ON	OFF	OFF	OFF	-	-
OFF	ON	OFF	OFF	ON	Basic para.	Basic para.
OFF	ON	OFF	ON	OFF	System para.	System para.
OFF	ON	OFF	ON	ON	-	-

The unit can be operated, even if no wiring is made to control power supply terminals L1C, L2C.

(o) T-link type : 0.4 and 0.75 [kW]

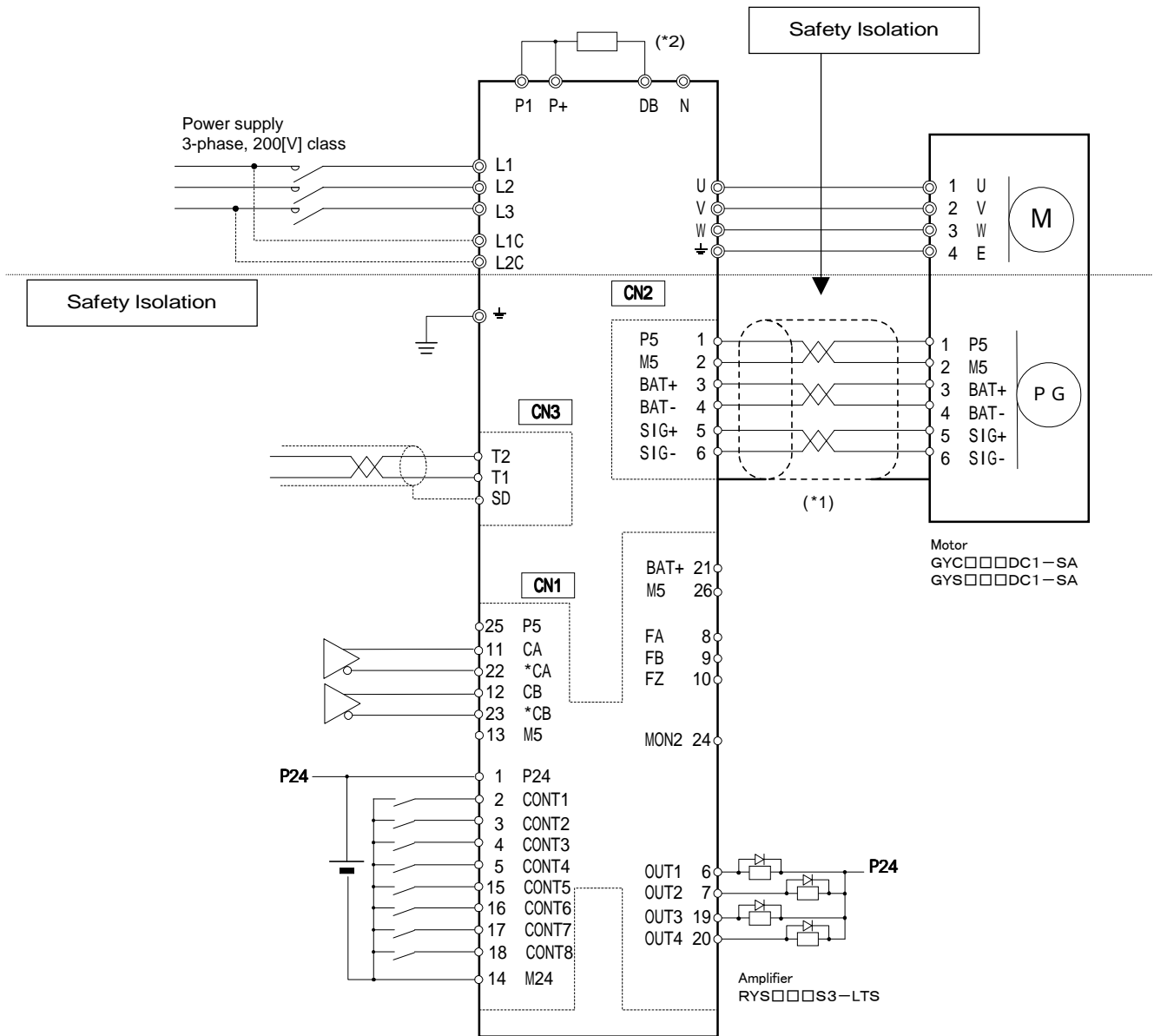

(\*1) Shielded sheath on the shielded cables must be connected with the shell body and the shell cover.

(\*2) A braking resistor is provided (built-in) with amplifier.

(p) T-link type : 1 and 1.5 [kW]

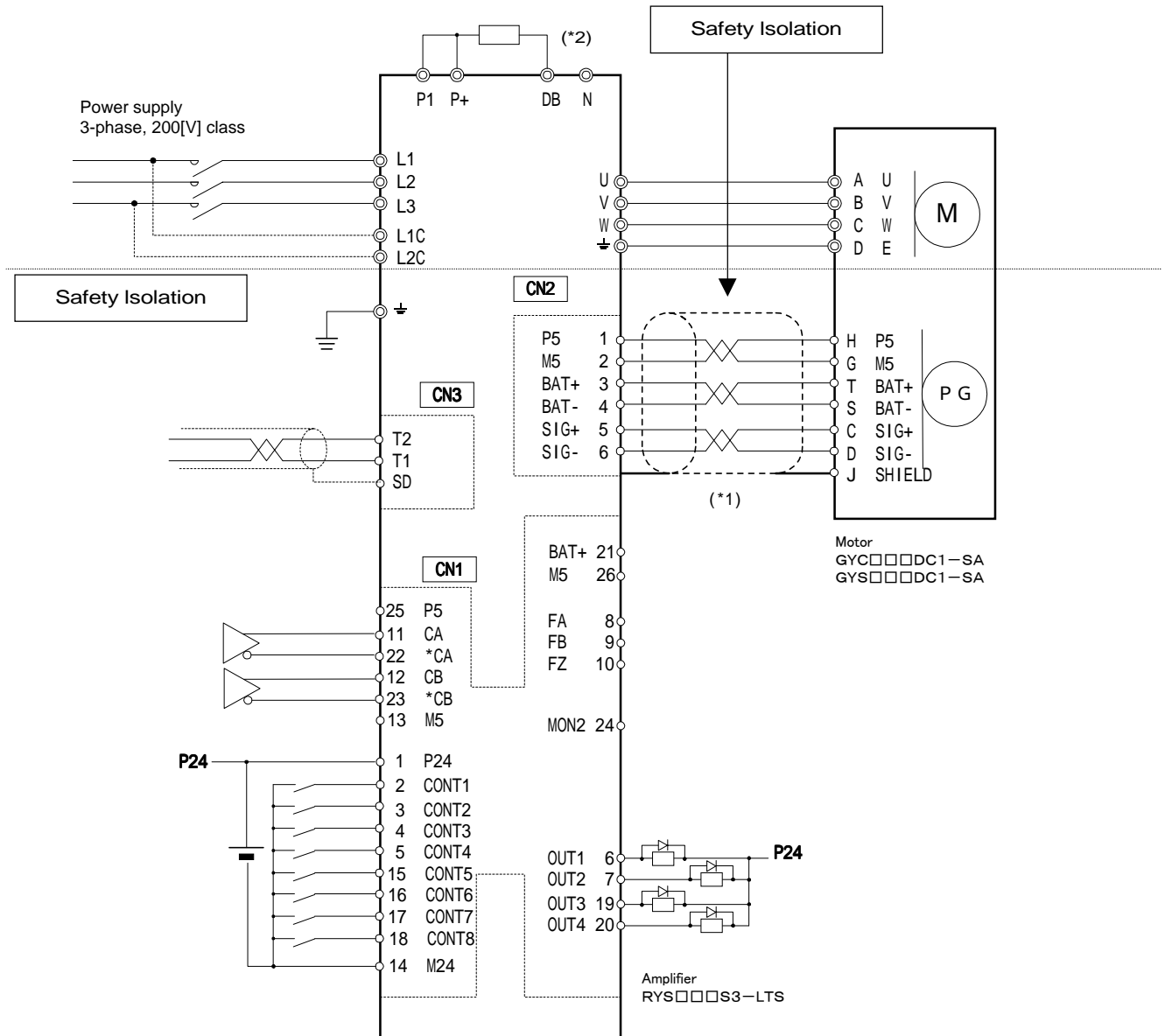

(\*1) Shielded sheath on the shielded cables must be connected with the J terminal and the shell cover.

(\*2) A braking resistor is provided (built-in) with amplifier.

(q) T-link type : 2 to 5 [kW]

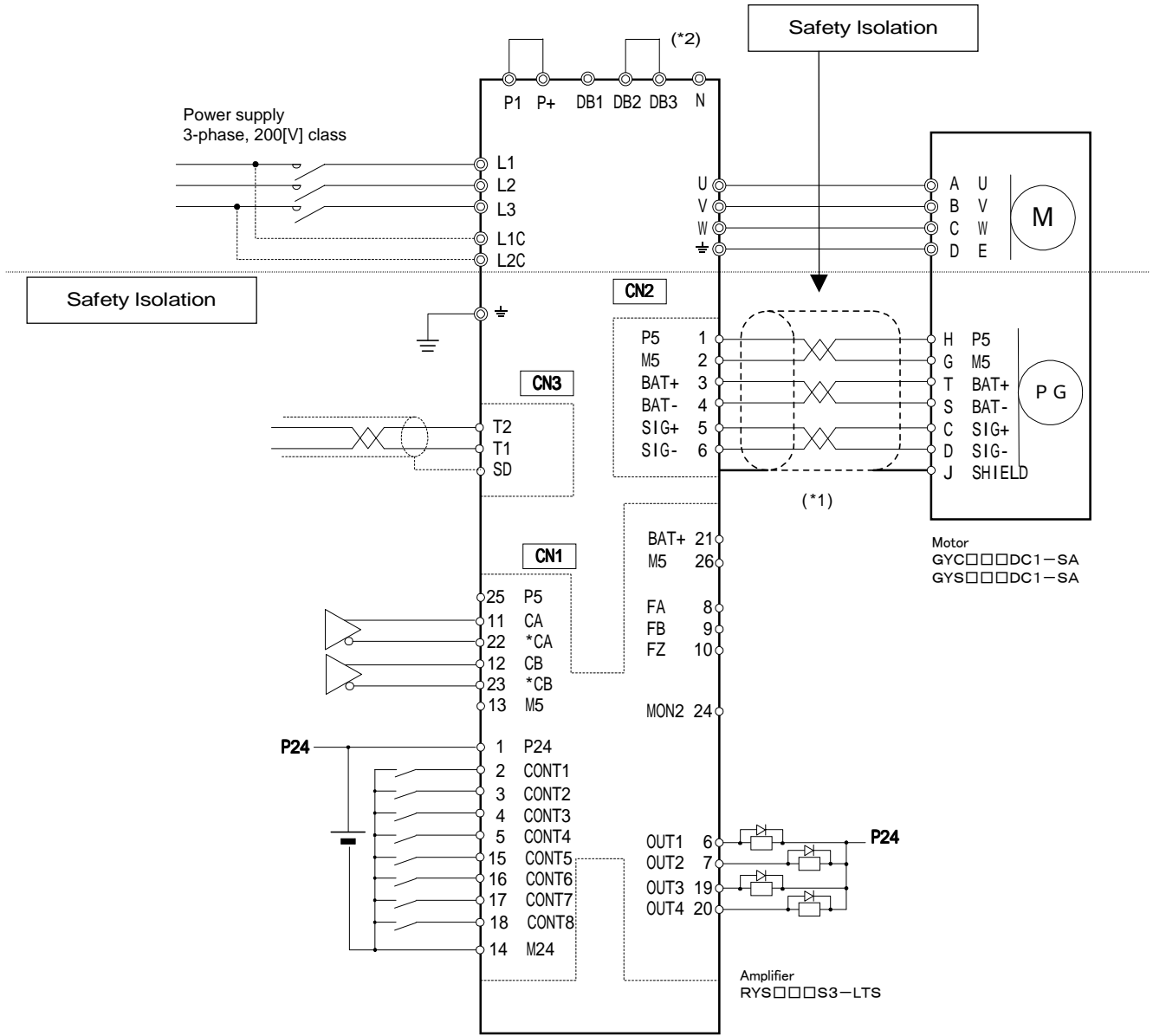

(\*1) Shielded sheath on the shielded cables must be connected with the J terminal and the shell cover.

(\*2) A braking resistor is provided (built-in) with amplifier.

(r) T-link type : 0.05 and 0.1 [kW] for 100 [V] class input voltage of amplifier

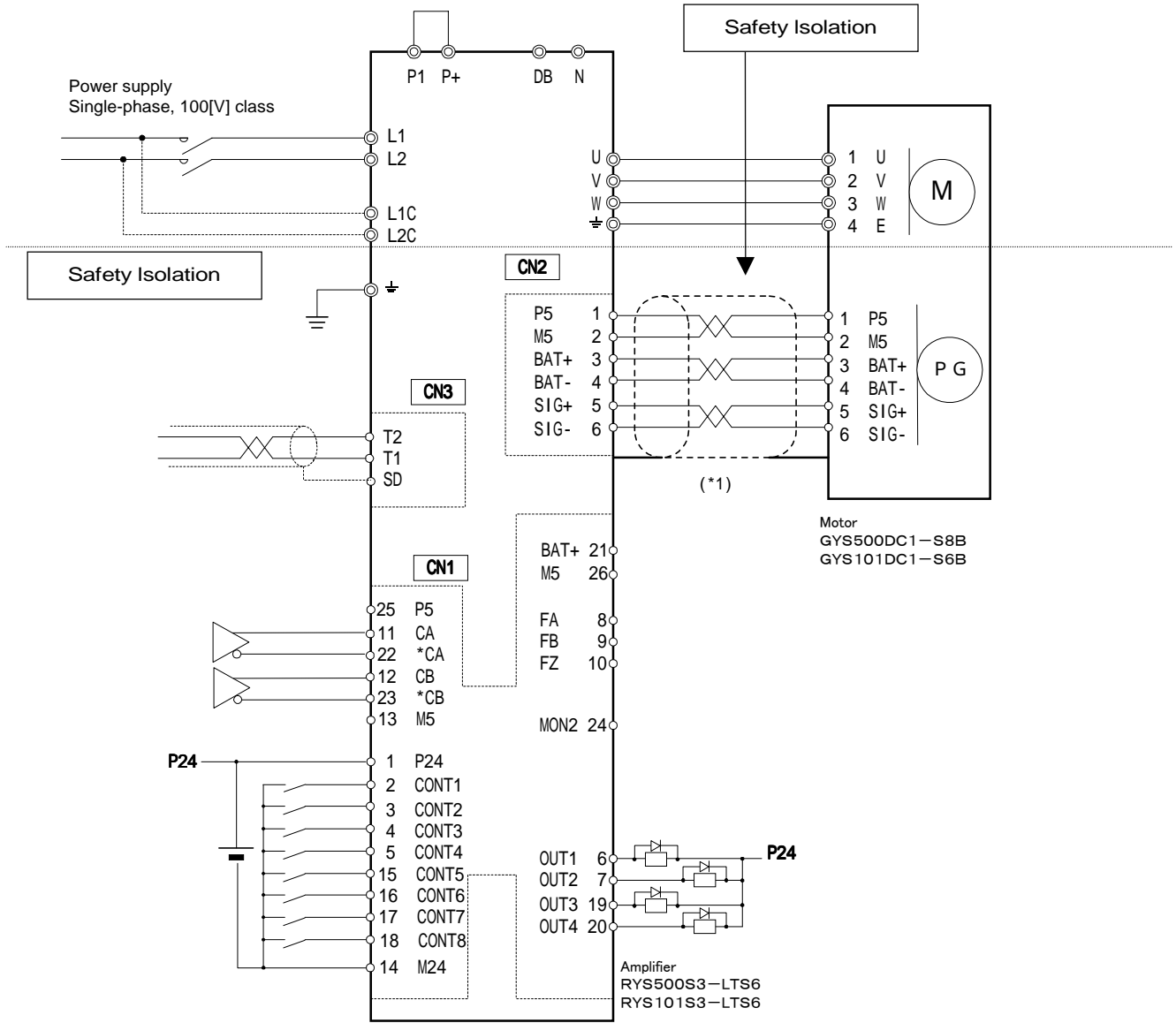

(\*1) Shielded sheath on the shielded cables must be connected with the shell body and the shell cover.

(s) T-link type : 0.2 [kW] for 100 [V] class input voltage of amplifier

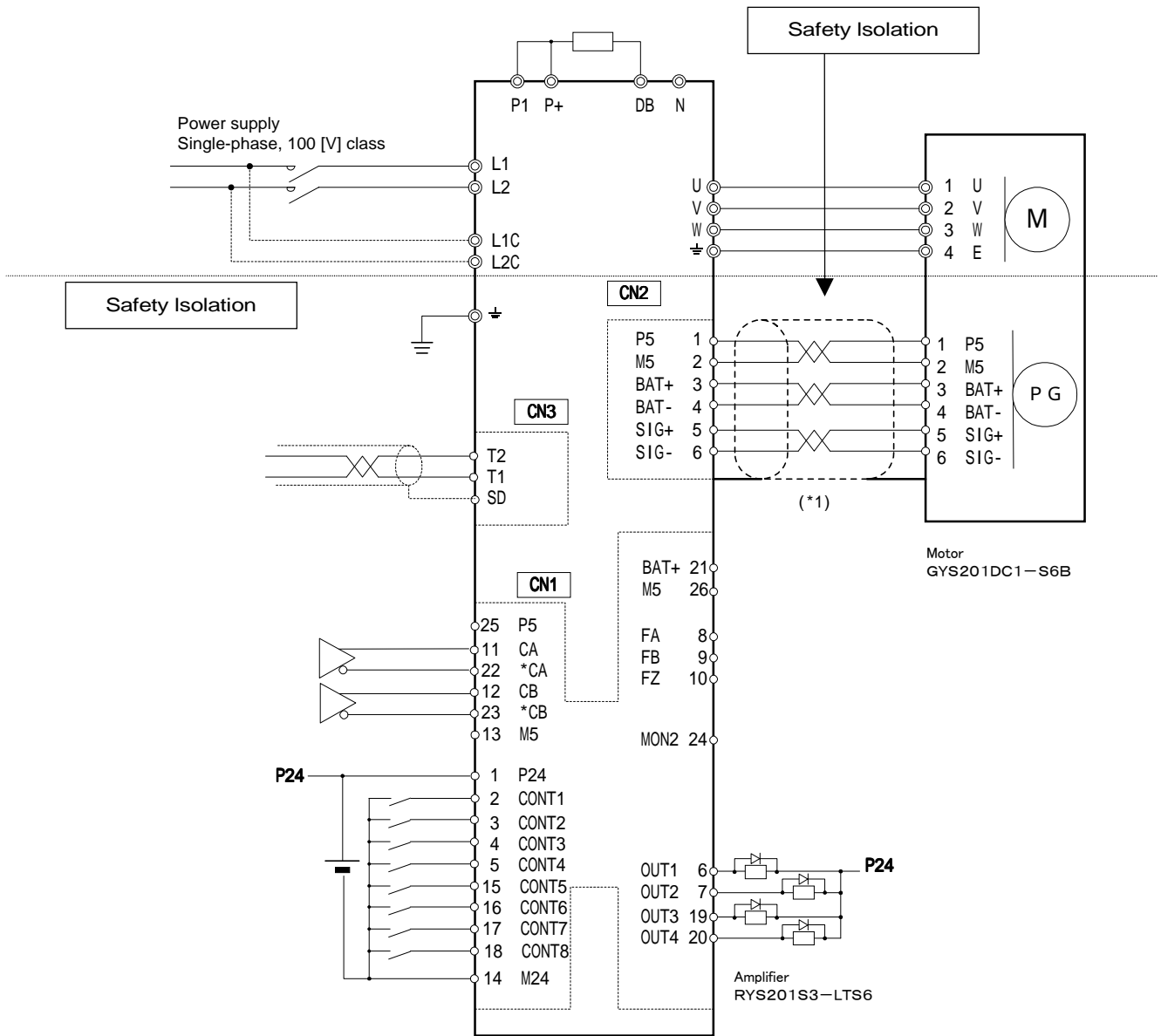

(\*1) Shielded sheath on the shielded cables must be connected with the shell body and the shell cover.

(t) General-purpose communication (RS485 interface) : 0.2 [kW] and below

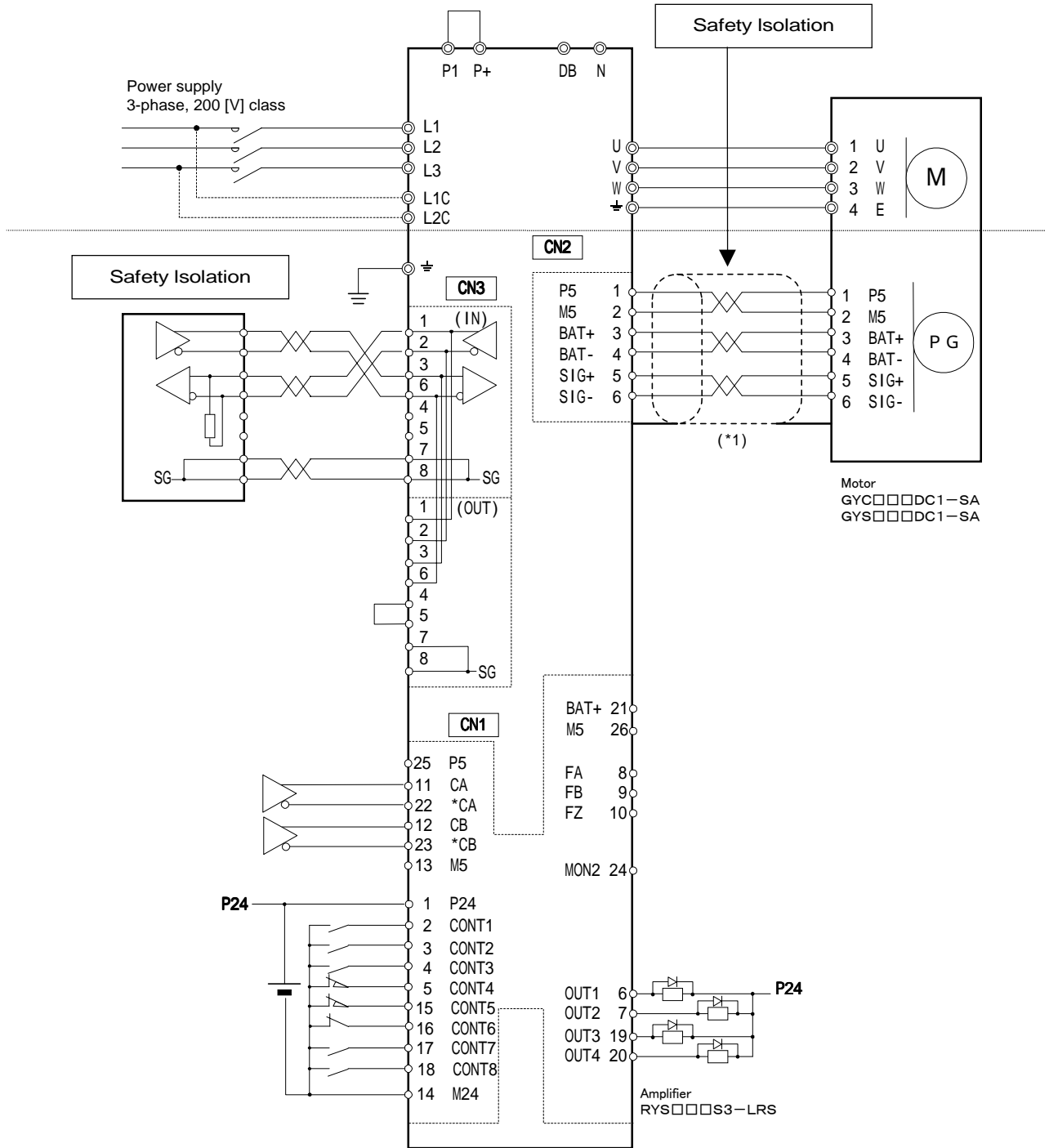

(\*1) Shielded sheath on the shielded cables must be connected with the shell body and the shell cover.

• CONT and OUT of CN1 terminals are initially assigned at factory:

Terminal symbol	CONT1	CONT2	CONT3	CONT4	CONT5	CONT6	CONT7	CONT8
Function	RUN (run command)	START (auto start)	LS (origin LS)	+ OT (+ direction overtravel)	- OT (- direction overtravel)	EMG (forced stop)	-	-

Terminal symbol	OUT1	OUT2	OUT3	OUT4
Function	RDY (ready)	PSET (positioning end)	-	-

• The unit can be operated, even if no wiring is made to control power supply terminals L1C, L2C.

(u) General-purpose communication (RS485 interface): 0.4 and, 0.75 [kW]

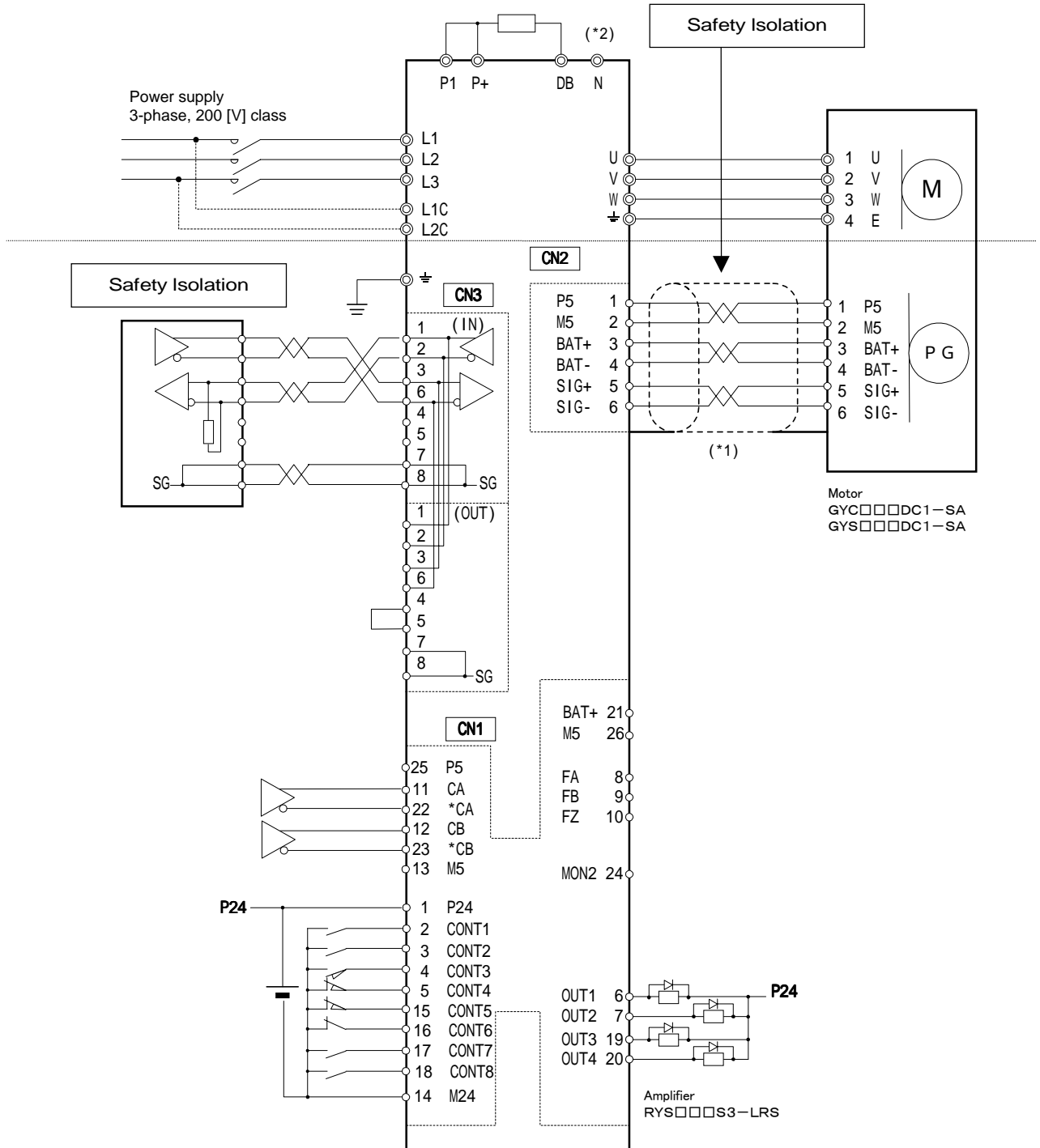

(\*1) Shielded sheath on the shielded cables must be connected with the shell body and the shell cover.

(\*2) A braking resistor is provided (built-in) with amplifier.

(v) General-purpose communication (RS485 interface): 1 and 1.5 [kW]

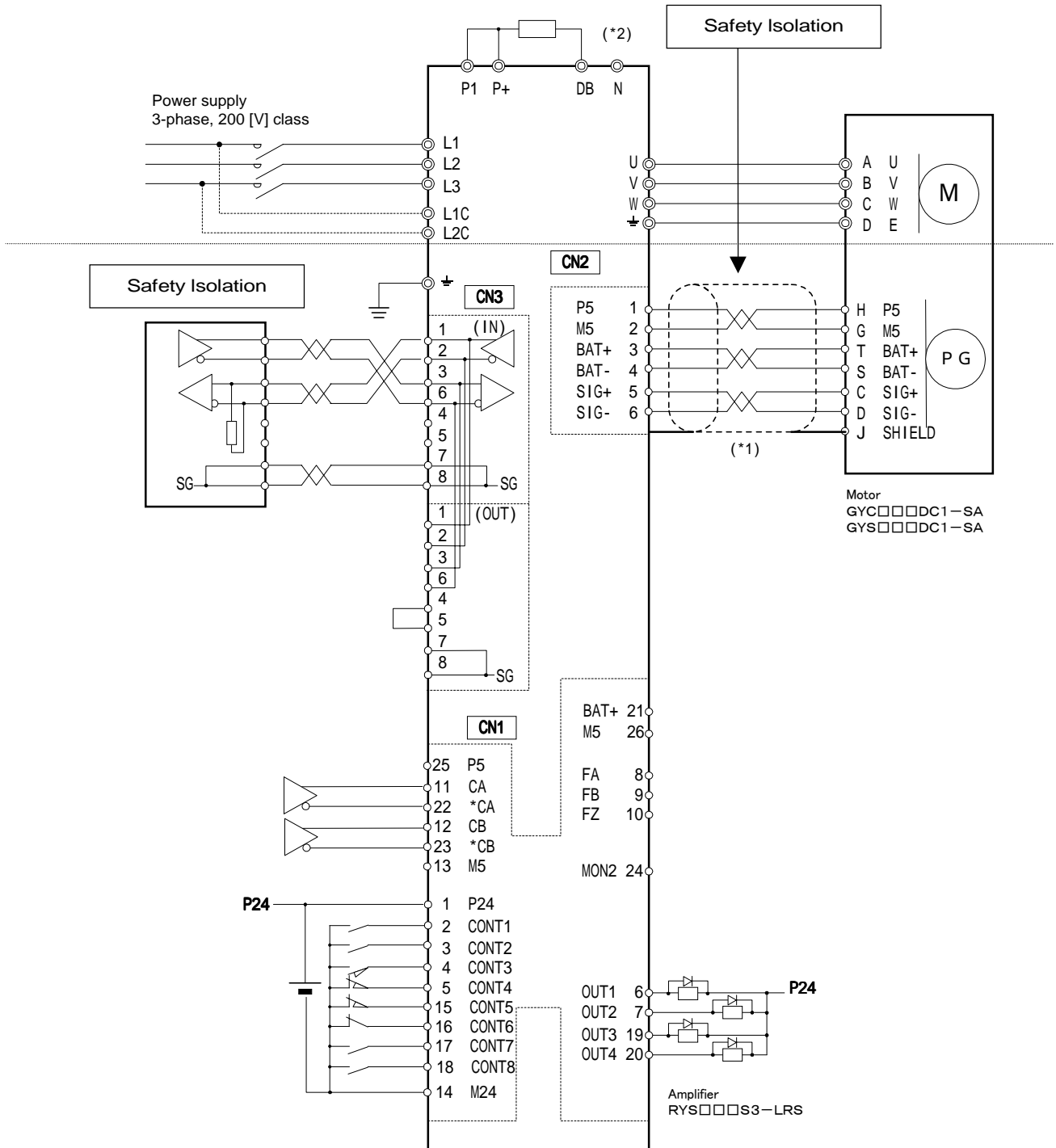

(\*1) Shielded sheath on the shielded cables must be connected with the J terminal and the shell cover.

(\*2) A braking resistor is provided (built-in) with amplifier.

(w) General-purpose communication (RS485 interface): 2 to 5 [kW]

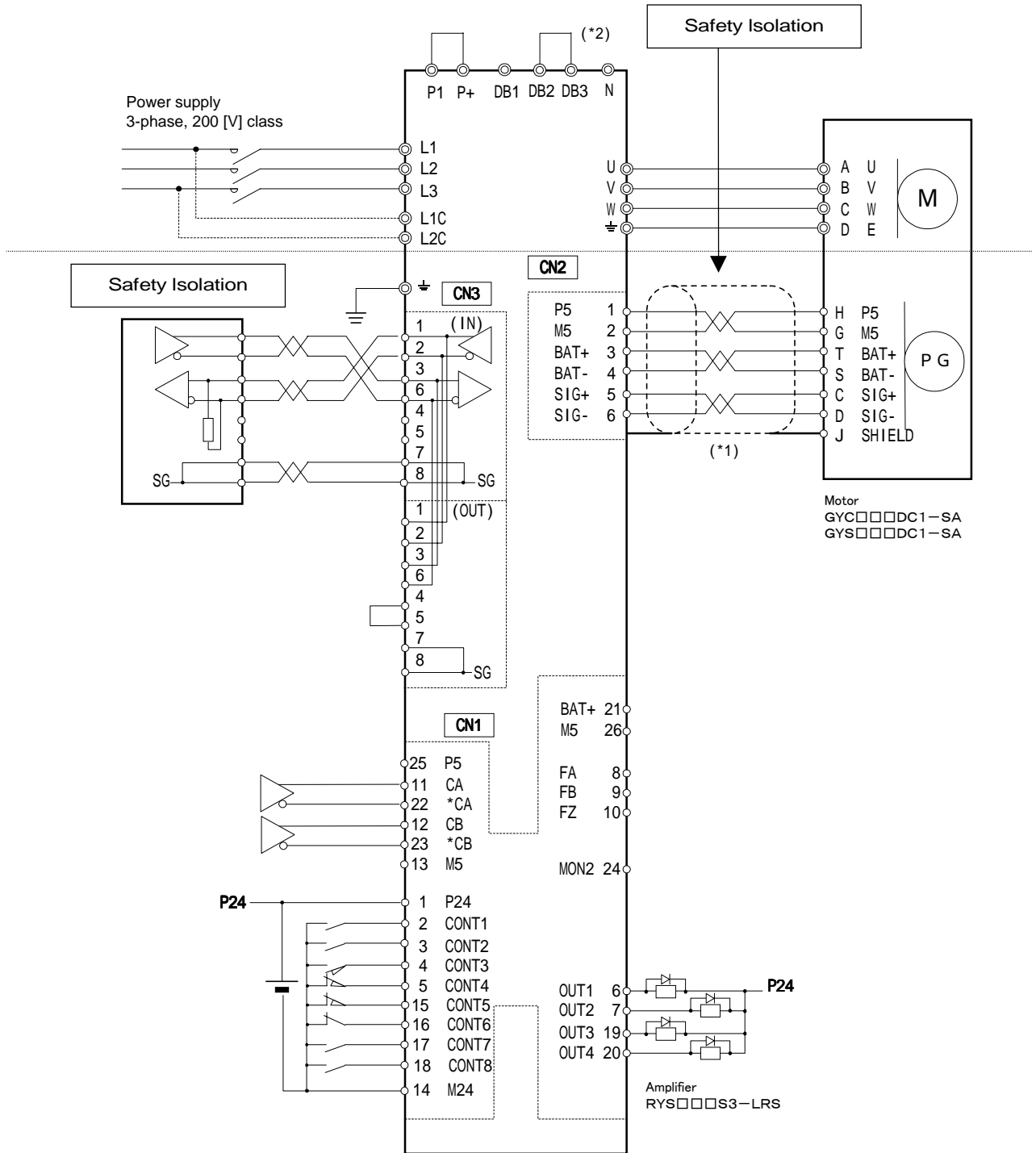

(\*1) Shielded sheath on the shielded cables must be connected with the J terminal and the shell cover.

(\*2) A braking resistor is provided (built-in) with amplifier.

(x) General-purpose communication (RS485 interface): 0.05 and 0.1 [kW] for 100 [V] class input voltage of amplifier

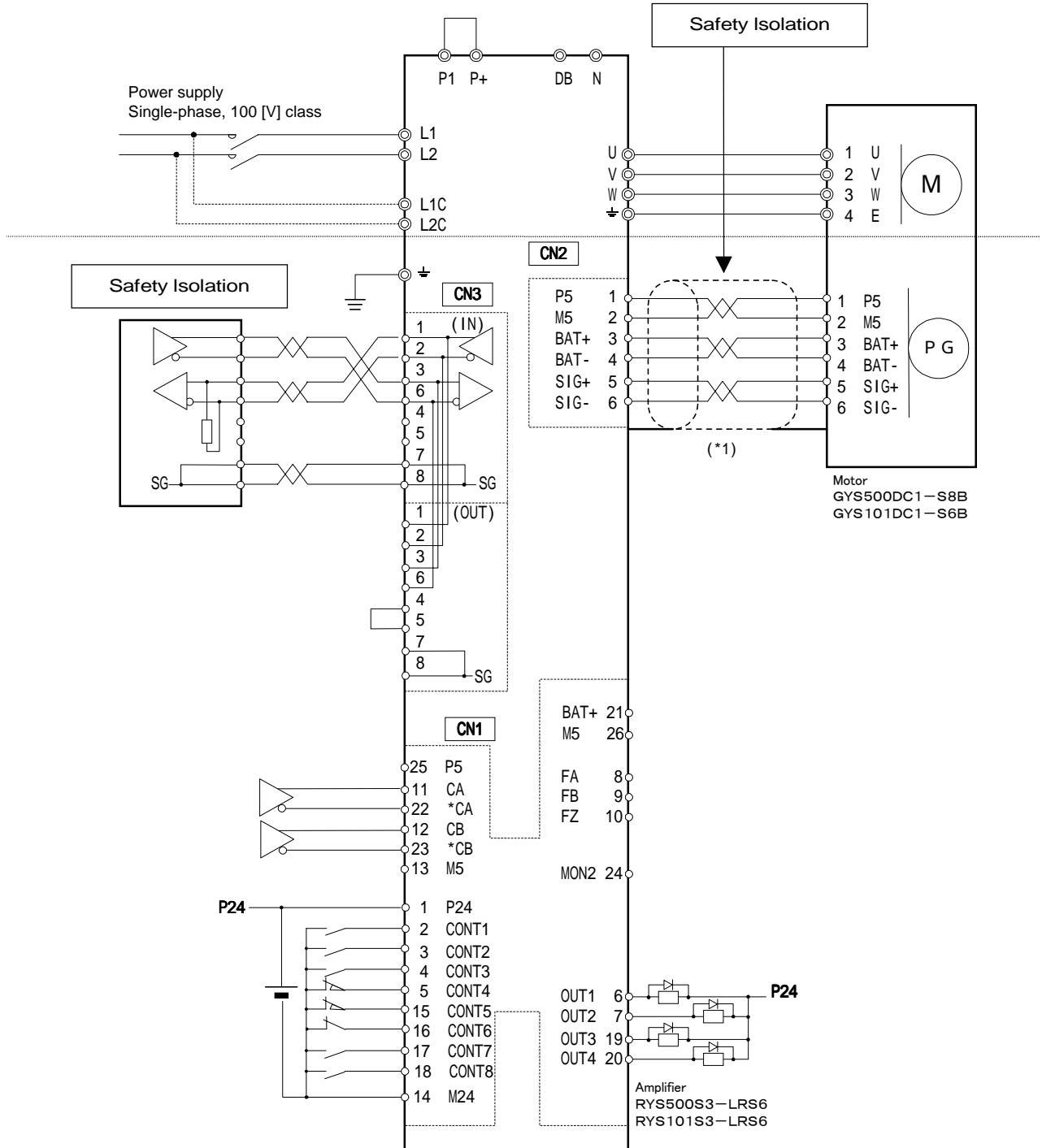

(\*1) Shielded sheath on the shielded cables must be connected with the shell body and the shell cover.

(y) General-purpose communication (RS485 interface): 0.2 [kW] for 100 [V] class input voltage of amplifier

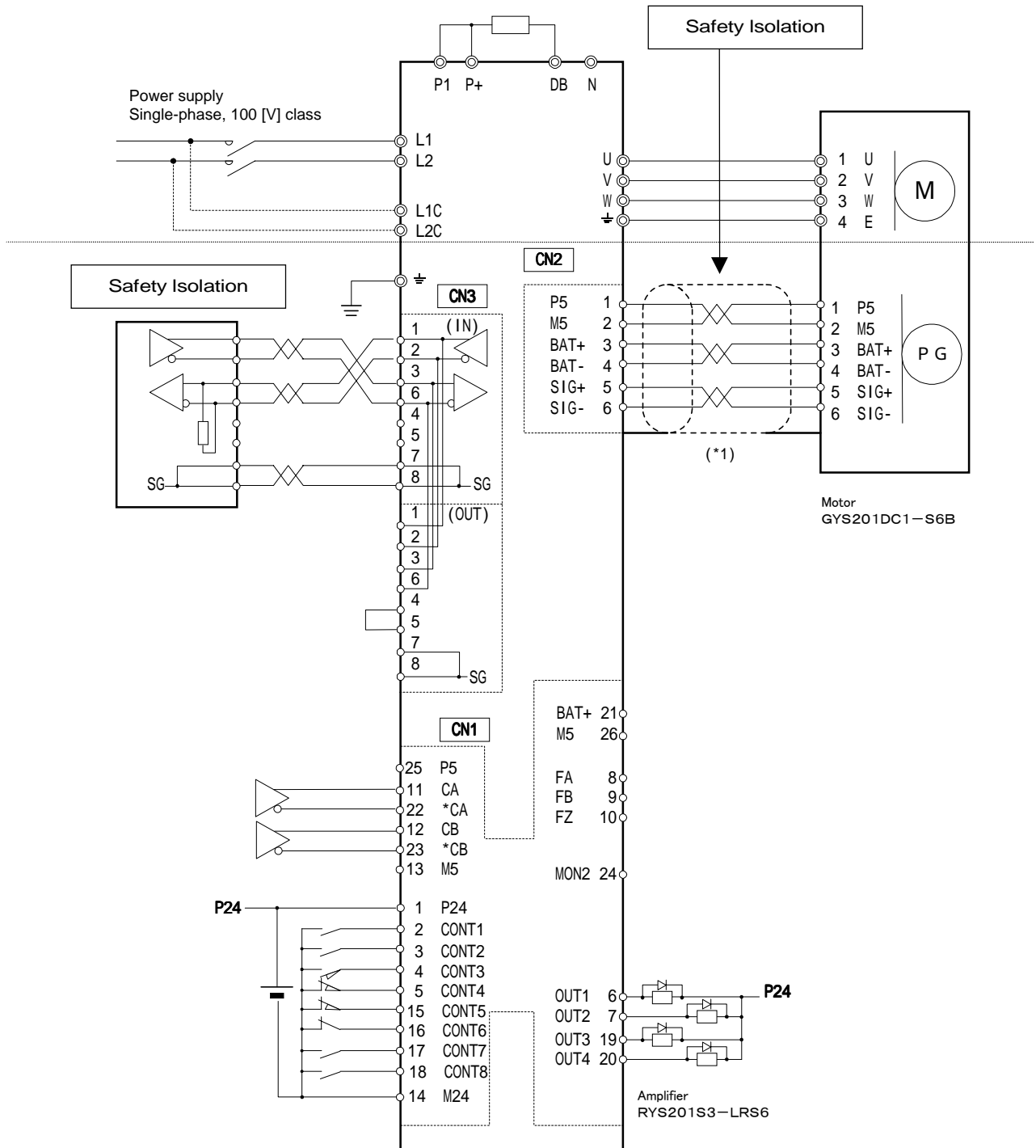

(\*)1) Shielded sheath on the shielded cables must be connected with the shell body and the shell cover.

**(2) External connection diagrams of RYS-V type amplifier and GYC type motor**

(a) Positioning unit : AD75

Typical connection with AD75 type positioning unit (Mitsubishi Electric Corp.) is shown below.

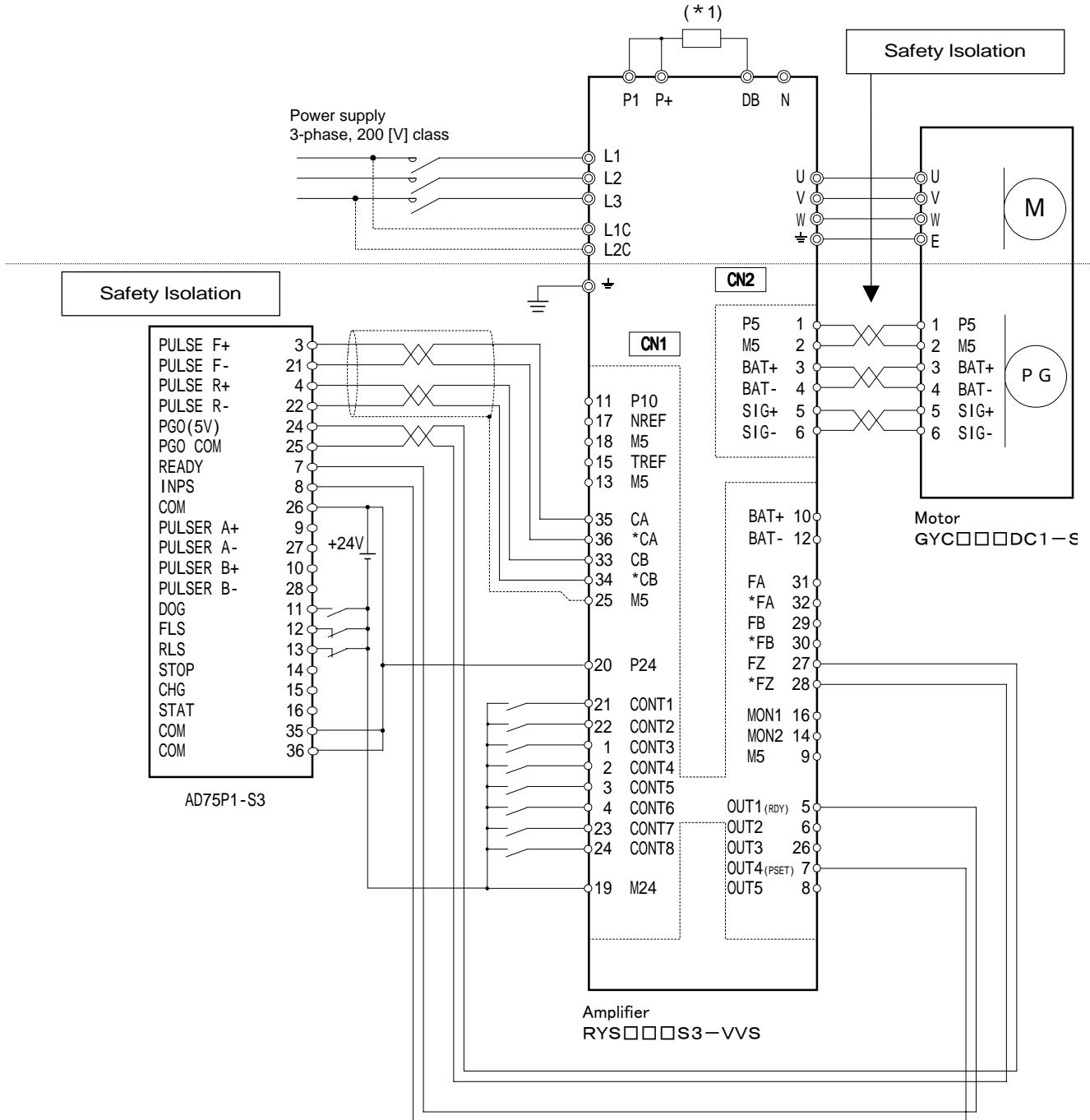

Notes :

(\*1) For 0.2 [kW] and below, braking resistor is not provided (built-in) with amplifier.

- The pulse output mode is used for CW/CCW (\*2) pulse output.
- CONT and OUT of CN1 terminals are initially assigned at factory :

Terminal symbol	CONT1	CONT2	CONT3	CONT4	CONT5	CONT6	CONT7	CONT8
Function (*4)	RUN	FWD	REV	RST	Multispeed selection X1	Multispeed selection X2	Pulse train ratio 1	Positioning control

Terminal symbol	OUT1	OUT2	OUT3	OUT4 (*3)	OUT5
Function (*4)	RDY	CPURDY	NZERO	PSET	

(\*2) Direction of motor shaft rotation (when viewed from a point facing the drive-end of motor) is designed according to Japanese standards :

- Forward direction : Counterclockwise (CCW) rotation
- Reverse direction : Clockwise (CW) rotation

(\*3) The assign number for positioning end [PSET] is "2".

- (\*4) CPURDY : CPU ready
- FWD : Forward command
- NZERO : Speed zero
- PSET : Positioning end
- RDY : Ready
- REV : Reverse command
- RST : Alarm reset
- RUN : Run command

(b) Position control unit : C200HW-NC113

Typical connection with C200HW-NC113 type position control unit (Omron Corp.) is shown below.

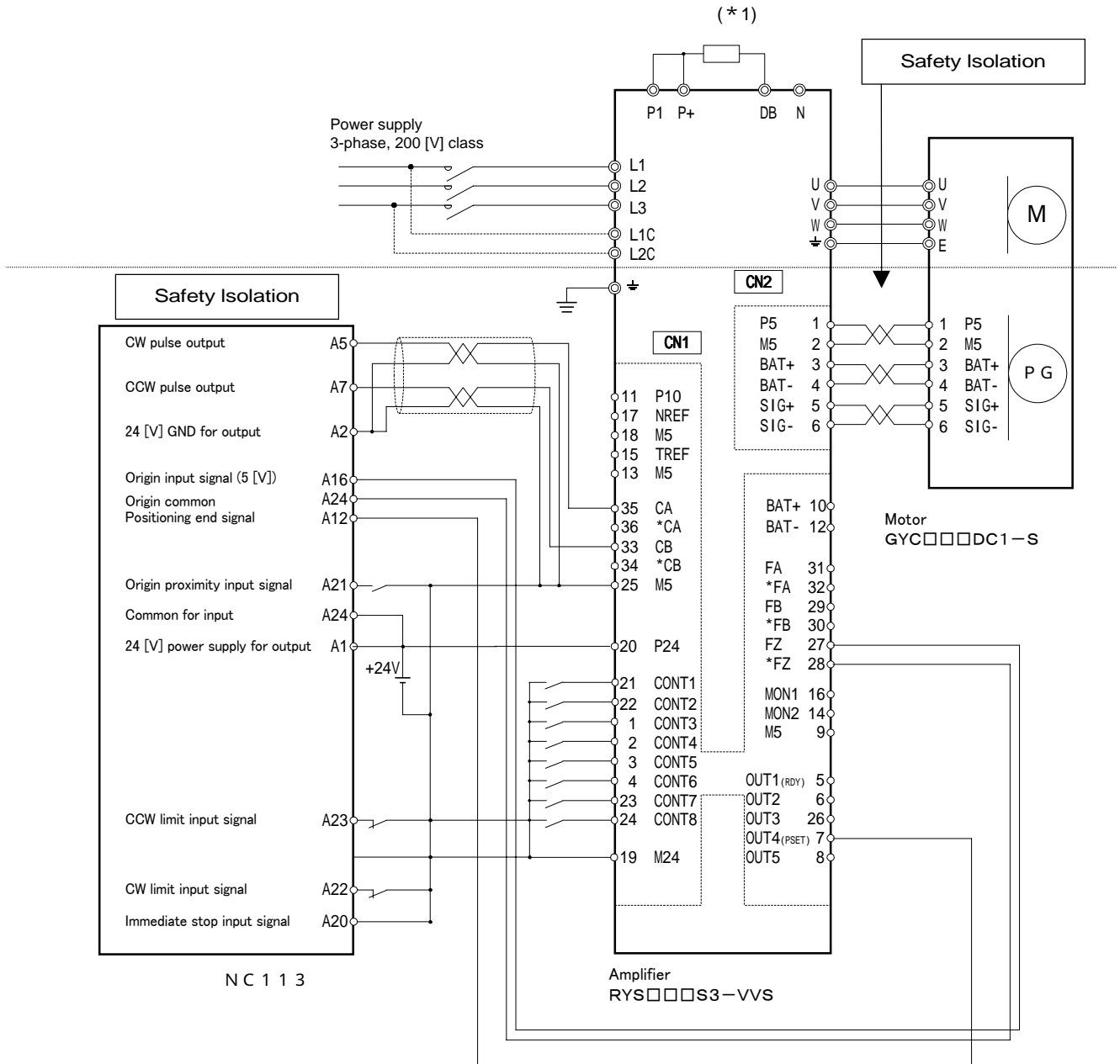

Notes :

(\*1) For 0.2 [kW] and below, braking resistor is not provided (built-in) with amplifier.

- The pulse output mode is used for CW/CCW (\*2) pulse output.
- CONT and OUT of CN1 terminals are initially assigned at factory :

Terminal symbol	CONT1	CONT2	CONT3	CONT4	CONT5	CONT6	CONT7	CONT8
Function (*4)	RUN	FWD	REV	RST	Multispeed selection X1   X2		Pulse train ratio 1	Positioning control

Terminal symbol	OUT1	OUT2	OUT3	OUT4 (*3)	OUT5
Function (*4)	RDY	CPURDY	NZERO	PSET	

(\*2) Direction of motor shaft rotation (when viewed from a point facing the drive-end of motor) is designed according to Japanese standards :

- Forward direction : Counterclockwise (CCW) rotation
- Reverse direction : Clockwise (CW) rotation

(\*3) The assign number for positioning end [PSET] is "2".

- (\*4) CPURDY : CPU ready                      PSET : Positioning end                      RST : Alarm reset  
 FWD : Forward command                      RDY : Ready                                              RUN : Run command  
 NZERO : Speed zero                              REV : Reverse command

## 5. CONTROL FUNCTIONS

### 5.1 Summary

The RYS-L type amplifier can compose a linear positioning system, combined with ball-screw, timing belt or other mechanical equipment systems.

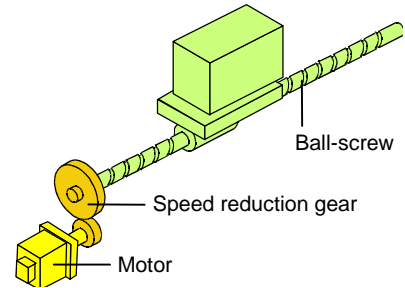

99 settings of positioning data can be registered in the amplifier.  
Each positioning data registers contents of one positioning action.  
Positioning data (address Nos.) are numbered 1 to 99 sequentially.

No.	指令方式	ステップモード	停止位置	回転速度	停止時間	Mコード	Mコード出力
11	ABS		0.00	0.01	0.00		
12	ABS		0.00	0.01	0.00		
13	ABS		0.00	0.01	0.00		
14	ABS		0.00	0.01	0.00		
15	ABS		0.00	0.01	0.00		
16	ABS		0.00	0.01	0.00		
17	ABS		100.00	3000.00	0.05		
18	ABS	CO	300.00	5000.00	0.00		
19	ABS	CEND	500.00	3000.00	0.05		
20	ABS		0.00	3000.00	0.05		
21	ABS		0.00	0.01	0.00		
22	ABS		0.00	0.01	0.00		
23	ABS		0.00	0.01	0.00		

Externally specifying an address No. and applying an auto start [START] starts positioning action according to its setting contents.

The setting contents of one positioning data are as follows.

Setting contents of positioning data

Position data (stop position)	-79999999 to 0 to 79999999 (in 1 step)[x unit q'ty]
Speed data (motor speed)	0.01 to max. speed [r/min] (in 0.01 step)
Timer data (dwell time)	0.0 to 655.35[s] (in 0.01 step)
Status (command method)	ABS/INC
Status (step mode)	CO (data continuation)/CEND (cycle end)
M code	00 to FF (1 step: simultaneous output/later-output settable)

For RYS-L type amplifier, following four kinds of host interface is available.

**RYS S3-LPS type, Basic type (DI/DO position)**

Controls motor according to control input/output signal (DI/DO level).

**RYS S3-LSS type, SX bus type (SX bus direct connection)**

Controls motor via SX bus. (\*1)

**RYS S3-LTS type, T-link type (T-link direct connection)**

Controls motor via T-link. (\*2)

**RYS S3-LRS type, RS485 interface type**

Controls motor via serial communication

(\*1) High speed serial bus (25 [MHz]) of MICREX-SX series PLC

(\*2) Save-wiring I/O link (total wiring length 1 [km]) of MICREX-F series PLC

The control function of each type is almost same but is a little different, depending on the host interface.

For the control functions, see

- 5.2 Run command
- 5.3 Manual operation
- 5.4 Origin return
- 5.5 Auto start
- 5.6 Signal for safety
- 5.7 Incidental functions

For SX bus type, see 5.8 IQ area (SX bus type)  
 For T-link type, see 5-9 WB area (T-link type)  
 For RS485, see 5-10 RS485 interface type

The main control functions of RYS-L type are as follows.

- Run command [RUN]

Powers on the motor or makes the motor free-run.

- Forward command [FWD]/Reverse command [REV]

Rotates the motor for the arbitrary time period.

- Origin return [ORG]/Origin LS [LS]

Detects the machine origin point.

- Auto start [START] (positioning data)

Operates according to positioning data registered in the amplifier.

- Auto start (immediate positioning)

Stop positioning can be specified from external.

- Incidental functions

Functions of temporary stop, positioning cancel, override, pulse train input (manual pulse generator), interrupt positioning, etc. are provided.

The main output signals from amplifier are as follows.

- Ready [RDY]

This signal turns on when the motor can be rotated.

- Positioning end [PSET]

This signal turns on when positioning end.

- Incidental functions

The signals of current position output, origin return end, torque limit detection, etc.. can be outputted.

The signal form of the [START] (immediate positioning) and the current position output varies depending on the host interface.

#### Auto start (immediate positioning)

Amplifier	Setting of position data
Basic type (DI/DO position)	Writes the data of divided position.
SX bus type (SX bus direct connection)	Writes the data of the specified position and the speed into IQ area.
T-link type (T-link direct connection)	Writes the data of the specified position into WB area.
RS485 interface	Writes the position data by operation command.

#### Current position output

Amplifier	Current position output
Basic type (DI/DO position)	Current divided position can be outputted.
SX bus type (SX bus direct connection)	Current position can be outputted to IQ area.
T-link type (T-link direct connection)	Current position can be outputted to WB area.
RS485 interface	Current position can be outputted as monitor data.

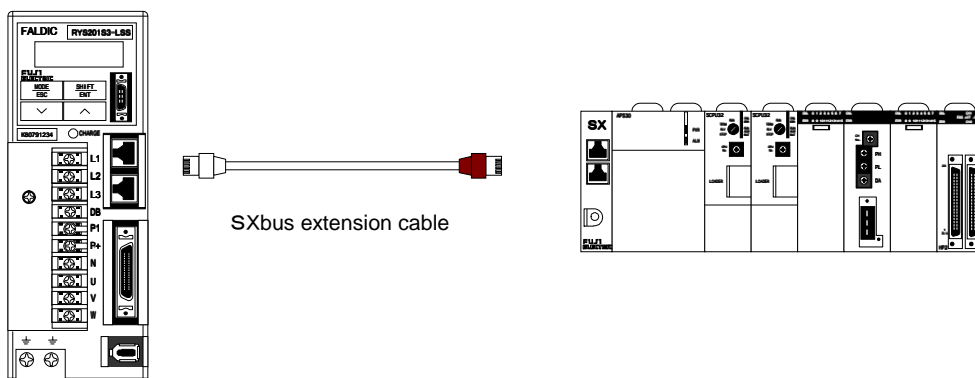

## 5.2 Run command

This section explains the signals to run the motor and the signals to reset alarm detection.

- Control input signal :
- Run command [RUN] (1)
  - Alarm reset [RST] (11)

- Control output signal :
- Ready [RDY] ( 1)
  - CPU ready [CPURDY] (28)
  - Alarm detection [ALM] (16)
  - Alarm code 0 [ALM0] (32)
  - Alarm code 1 [ALM1] (33)
  - Alarm code 2 [ALM2] (34)
  - Alarm code 3 [ALM3] (35)
  - Alarm code 4 [ALM4] (36)

### 5.2.1 Run command [RUN]

The signal allows the motor to rotate.

---

Run command [RUN] (Control input signal)

---

#### Function

While the [RUN] signal is on, the motor is powered on and can rotate.

Even if commercial power is applied to amplifier, the motor will not start running while [RUN] is off.

When turning off this [RUN] signal while motor is running, motor decelerates quickly until it stops. After the stoppage, it is not held. No holding torque is available after the motor stops.

While the [RUN] signal is turned off, all rotational commands are ignored.

Basically, motor can be rotated when [RUN] is on and the forced stop [EMG] signal is on.

While the [RUN] signal is on and other signals are off, the motor is in stopping condition.

#### Parameter setting

To allocate the [RUN] signal to the control input terminal, set (1) to the system para. (\*). If this signal is not allocated to the control input terminal, this signal is deemed "always off".

#### Related item

For the [EMG] signal, see 5.6.1 Forced stop [EMG]/Forced stop detection.

### 5.2.2 Ready [RDY]

This signal turns on when the motor can be rotated.

---

Ready [RDY] (Control output signal)

---

#### Function

Listed below are five conditions for turning on this signal.

- 1) Run command [RUN] (1) signal on
- 2) Forced stop [EMG] (10) signal on
- 3) Alarm detection (16) signal off
- 4) External fault input (34) signal on
- 5) Free-run [BX] (54) signal off

When the host controller receives the on/off status of [RDY] signal, it recognizes that the motor can be rotated.

#### Parameter setting

To allocate the [RDY] signal to the control output terminal, set (1) to the system para..

#### Related item

The amplifier can the CPU ready [CPURDY] (28) output signal, which is turned on when the power is being supplied to amplifier and the internal CPU is processing normally.

Note: (\*) para.: parameter

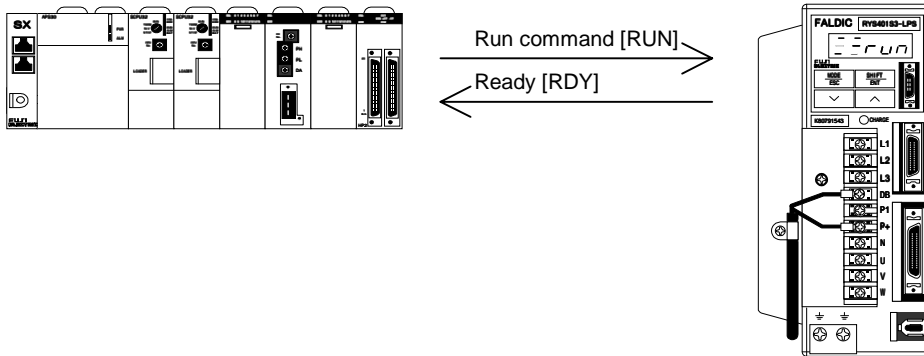

### 5.2.3 Alarm reset [RST]

This signal input resets the alarm detection from the amplifier.

---

#### Alarm reset [RST] (Control input signal)

---

##### Function

At the ON edge of [RST] signal of control input signals, the alarm detection can be reset. Alarm detection can also be reset in the test running mode [Fn004] by keypad panel. Alarm detection can also be reset by turning on power supply again.

##### Parameter setting

To allocate the [RST] signal to the control input terminal, set (11) to the system para. If this signal is not allocated to the control input terminal, this signal is deemed "always off".

##### Related item

Resetting method of the alarm detection is as listed below:

- 1) At the ON edge of [RST] signal of control input signal
  - 2) ENT key operation in the test running mode [Fn004]
  - 3) Press key and key simultaneously (longer than 1 [s]) at alarm detection [Sn003].
  - 4) Press key and key simultaneously (longer than 1 [s]) at alarm history [Sn004].
  - 5) Turn power off and turn on again
- To initialize the history [Fn005] of alarm detection, press ENT key in the test running mode.

### 5.2.4 Alarm detection [ALM]

This signal is turned on, when the amplifier protective function is activated (detects an alarm).

---

#### Alarm detection [ALM] (Control output signal)

---

##### Function

This signal is on when amplifier detects alarm, and retained by amplifier. The signal is turned off at the ON edge of alarm reset [RST] signal after the cause of alarm is removed (Motor running is enable). Alarm or no alarm can be recognized, when the host controller receives the on/off status of the [ALM] signal. This also can be recognized whether the ready [RDY] signal is off when the run command [RUN] is on.

##### Parameter setting

To allocate the [ALM] signal to the control output terminal, set (16) to the system para..

Related item

The contents of alarm detection can also be outputted to the control output terminals by alarm code.

Alarm code 4 [ALM4] (36)                      Alarm code 3 [ALM3] (35)

Alarm code 2 [ALM2] (34)                      Alarm code 1 [ALM1] (33)

Alarm code 0 [ALM0] (32)

For SX bus type (SX bus direct connection), alarm code is outputted at +5 word position of IQ area.

For T-link type (T-link direct connection), alarm code is outputted at +1 word position of WB area.

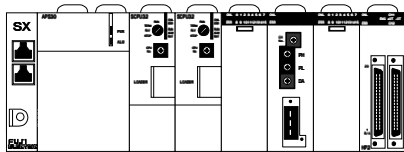

← Alarm detection [ALM]

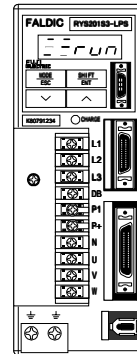

[ALM4]	[ALM3]	[ALM2]	[ALM1]	[ALM0]	Detection contents (*2)	Indication	Order of priority
OFF	OFF	OFF	OFF	OFF	(No detection)	AL---	22
OFF	OFF	OFF	OFF	ON	Motor overload	AL OL	14
OFF	OFF	OFF	ON	OFF			
OFF	OFF	OFF	ON	ON	Amplifier overheat	AL AH	17
OFF	OFF	ON	OFF	OFF	Braking resistor overheat	AL rH	15
OFF	OFF	ON	OFF	ON	Deviation excessive	AL OF	16
OFF	OFF	ON	ON	OFF	Overcurrent	AL OC	2
OFF	OFF	ON	ON	ON	Overspeed	AL OS	3
OFF	ON	OFF	OFF	OFF	Overvoltage	AL HU	5
OFF	ON	OFF	OFF	ON	Undervoltage	AL LU	4
OFF	ON	OFF	ON	OFF	Encoder trouble (*3)	AL EE	6
OFF	ON	OFF	ON	ON			
OFF	ON	ON	OFF	OFF	Control power trouble (*3)	AL CE	7
OFF	ON	ON	OFF	ON	Memory error (*3)	AL dE	8
OFF	ON	ON	ON	OFF			
OFF	ON	ON	ON	ON	Fuse blown	AL Fb	9
ON	OFF	OFF	OFF	OFF			
ON	OFF	OFF	OFF	ON	Encoder communication error	AL EC	12
ON	OFF	OFF	ON	OFF	Motor combination error	AL CE	10
ON	OFF	OFF	ON	ON	Resistor overheat 2	AL rH2	11
ON	OFF	ON	OFF	OFF	Control signal error (*3)	AL CEE	13
ON	OFF	ON	OFF	ON	Encoder overheat	AL EH	18
ON	OFF	ON	ON	OFF	ABS (absolute) data lost (*4)	AL AL	19
ON	OFF	ON	ON	ON	Absolute data overflow	AL AF	20
ON	ON	OFF	OFF	OFF	Bus communication error	AL BE	21
ON	ON	OFF	OFF	ON			
ON	ON	OFF	ON	ON	Address error (BCD error) (*1)		
ON	ON	ON	OFF	OFF	Address error (out of range) (*1)		
ON	ON	ON	OFF	ON	(negative sign specified) (*1)		
ON	ON	ON	ON	OFF			
ON	ON	ON	ON	ON	System error	AL SE	1

(\*1) BCD error, out of range, and negative sign specified are not included in the alarm detection (protective function activation).

(\*2) If several alarms are simultaneously detected, the output priority is given as on the table above.

(\*3) The [RST] signal cannot release the alarm detection. Turn on power supply again.

(\*4) The [RST] signal cannot release the alarm detection. Reset it by inputting the position preset signal.

The contents of detected alarm can be outputted in code.

When alarm detection is released, all of the output is turned off.

### 5.3 Manual operation

The section explains the control input signals to run or control the motor speed at the ON level.

- |                                                                                                                                                                                                                                                                                                                                                                                                                                                                                                                           |                                                                                                                                                                                                                                               |
|---------------------------------------------------------------------------------------------------------------------------------------------------------------------------------------------------------------------------------------------------------------------------------------------------------------------------------------------------------------------------------------------------------------------------------------------------------------------------------------------------------------------------|-----------------------------------------------------------------------------------------------------------------------------------------------------------------------------------------------------------------------------------------------|
| <p>Control input signal :</p> <ul style="list-style-type: none"> <li>• Forward command [FWD] (2)</li> <li>• Reverse command [REV] (3)</li> <li>• Pulse train ratio 1 (27)</li> <li>• Pulse train ratio 2 (28)</li> <li>• Deviation clear (50)</li> <li>• Multistep speed selection X 1 [X1] (51)</li> <li>• Multistep speed selection X 2 [X2] (52)</li> <li>• Multistep speed selection X 3 [X3] (53)</li> <li>• Acceleration/deceleration time selection [ACC0] (14)</li> <li>• Speed command [NREF] (fixed)</li> </ul> | <p>Control output signal :</p> <ul style="list-style-type: none"> <li>• Deviation zero (23)</li> <li>• Deviation excessive [OF] (alarm detection is issued)</li> <li>• Speed zero [NZERO] (24)</li> <li>• Speed arrive [NARV] (25)</li> </ul> |
|---------------------------------------------------------------------------------------------------------------------------------------------------------------------------------------------------------------------------------------------------------------------------------------------------------------------------------------------------------------------------------------------------------------------------------------------------------------------------------------------------------------------------|-----------------------------------------------------------------------------------------------------------------------------------------------------------------------------------------------------------------------------------------------|

#### 5.3.1 Forward command [FWD] / Reverse command [REV]

These signals rotate the motor.

---

Forward command [FWD] / Reverse command [REV] (Control input signal)

---

##### Function

While the [FWD] ([REV]) signal is on, the motor rotates forward (in reverse). Acceleration starts at the ON edge, deceleration starts at the OFF edge.

Simultaneous turning on both [FWD] and [REV], does not stop the motor.

The motor rotates at a speed selected by multistep speed selection [X1], [X2] or [X3].

##### Multistep speed selection [X1], [X2], [X3]

[X3]	[X2]	[X1]	Speed
OFF	OFF	OFF	(see below.)
OFF	OFF	ON	Speed set by basic para. 01
OFF	ON	OFF	Speed set by basic para. 02
OFF	ON	ON	Speed set by basic para. 03
ON	OFF	OFF	Speed set by basic para. 04
ON	OFF	ON	Speed set by basic para. 05
ON	ON	OFF	Speed set by basic para. 06
ON	ON	ON	Speed set by basic para. 07

Min. value in IQ area and WB area is equivalent to 0.01 [r/min].

Basic type (DI/DO) : [NREF] terminal

SX bus type (SX bus direct connection) : IQ area (+10, +11)

T-link type (T-link direct connection) : WB area (+7, +8)

RS485 interface: Basic para. only

##### Parameter setting

To allocate the [FWD] signal to the control input terminal, set (2) to the system para. (set (3) for the [REV]).

If these signals are not allocated to the control input terminal, these signals are deemed "always off".

##### Related items

(1) Changeover of acceleration/deceleration time

The accel. and decel.(\*) time of motor can be set by basic para. 21 to 24. The accel. time and decel. time can be set separately.

The accel. time is set by the basic para. 21 or 23, regardless of rotational direction.

Accel. time (basic para. 21 or 23) can be selected by the accel./decel. time selection [ACC0] setting.

Note: (\*) Accel. : Acceleration, Decel. : Deceleration

### Selection of acceleration and deceleration time

[ACC0] (14)	Accel. time	Decel. time
OFF	Basic para. 21	Basic para. 22
ON	Basic para. 23	Basic para. 24

To allocate the [ACC0] signal to the control input terminal, set (14) to the system para.. If this signal is not allocated to the control input terminal, this signal is deemed "always off".

### (2) Changeover of rotational direction

The rotational direction of motor output shaft for the [FWD] can be changed by the system para. 80.

When the para. 80 is initial value (\*1), motor rotates in forward (counterclockwise (\*2) viewed from shaft extension) direction for forward command. In case the motor rotates opposite to the normal movement of mechanical equipment system, set 1 at the para. 80. The setting change of the system para. becomes valid after turning on power again.

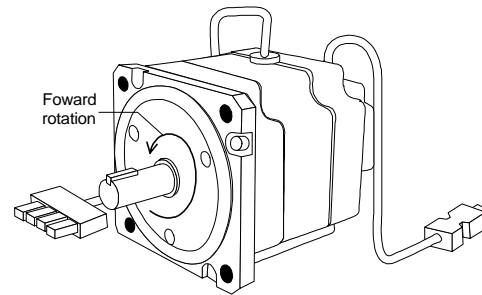

### (3) Gain for speed command [NREF] terminal : Basic type (DI/DO position) only

At factory setting, the motor rotates forward at 5000 [r/min] against +10 [V] of the speed command voltage. By setting the system para. 63, the motor speed can be adjusted against the set speed command voltage.

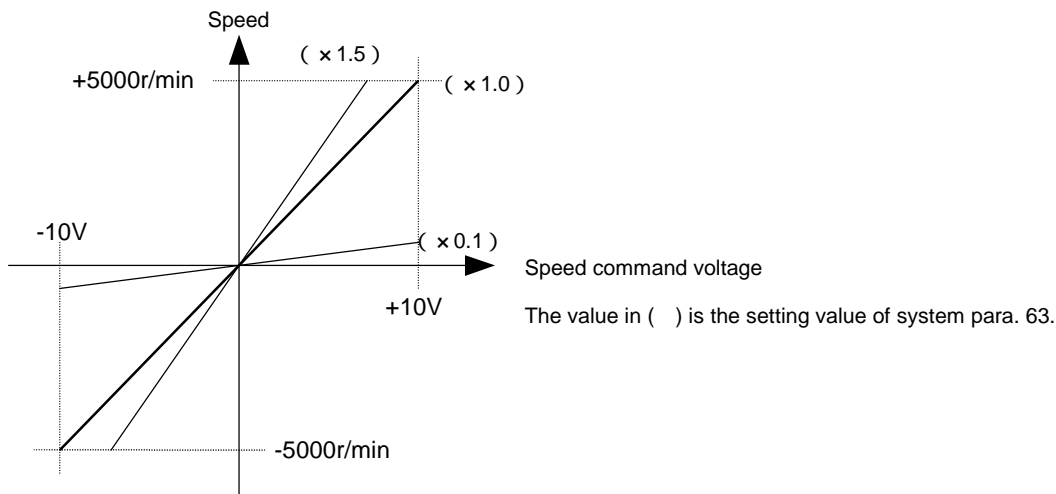

If the system para. 63 has been set at 0.1, the speed can be adjusted to 500 [r/min] against +10 [V] of the speed command voltage.

### (4) Resolution of speed command voltage : Basic type (DI/DO position) only

The [NREF] terminal has a 14 bit resolution at full scale.

### (5) Torque limit

Motor output torque can be limited by using the torque limit [TLMT] (30) signal. For details, see 5.6.3 Torque limit [TLMT]/Torque limit detection.

### (6) Non-linear (S-curve) acceleration/deceleration

S-curve accel./decel. can be carried out by basic para. 25 setting.

The speed slowly increases by drawing an S-curve, and a mechanical shock during acceleration can be reduced.

### Notes :

(\*1) Initial value has been set individually, at the time of shipment from our factory.

(\*2) Direction of motor shaft rotation (when viewed from a point facing the drive-end of motor) is designed according to Japanese standard :

- Forward direction : Counterclockwise (CCW) rotation
- Reverse direction : Clockwise (CW) rotation

### 5.3.2 Pulse train ratio 1/Pulse train ratio 2

The signal validates a pulse train from the manual pulse generator, etc.

---

Pulse train ratio 1 / Pulse train ratio 2 (Control input signal)

---

#### Function

While the pulse train ratio 1 (27) is turned on, the pulse train input is valid.  
Turning it off ignores the pulse train input.

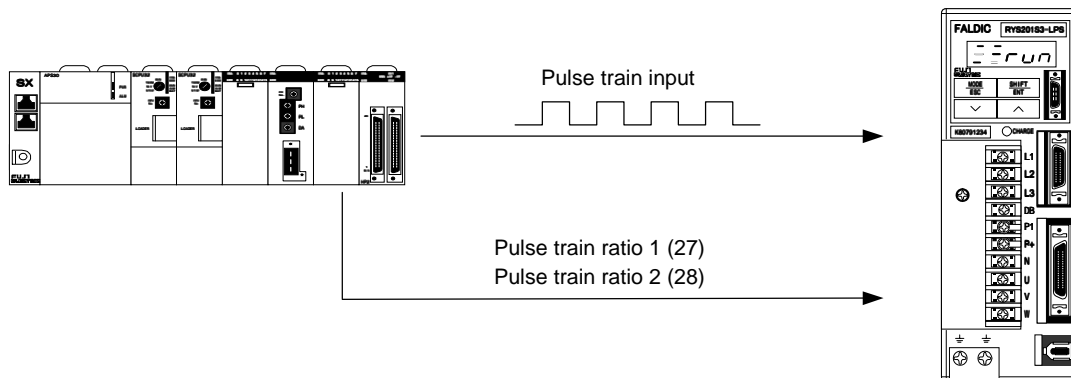

Pulse train ratio 1 validates the pulse train ratio 1 by basic para. 93, or pulse train ratio 2 validates the pulse train ratio 2 by basic para. 94. While the pulse train ratio 1 or pulse train ratio 2 is on, and the pulse train input is valid, the manual feed (forward/reverse command [FWD]/[REV]), origin return [ORG], auto start [START] and interrupt positioning do not become valid. The temporary stop and positioning cancel signals are invalid to the pulse train input is on.

#### Parameter setting

To allocate the pulse train ratio 1 to the control input terminal, set (27) to the system para.. Set (28) for the pulse train ratio 2. If these signals are not allocated to the control input terminals, these signals are deemed "always off".

#### Related items

(1) Pulse correction (basic para. 91)/Pulse correction (basic para. 92)

At factory setting, the motor rotates by the rotational quantity per encoder 1 [pulse] in response to 1 [pulse] of pulse train input. In normal encoder, one rotation of motor shaft corresponds to 65536 [pulse]. Motor rotational quantity in response to 1 [pulse] of pulse train input can be changed.

#### Basic parameter 91, 92

Para.	Name	Setting range	Initial value	Change
91	Command pulse correction	1 to 32767 (in 1 step)	8	Always
92	Command pulse correction	1 to 32767 (in 1 step)	1	Always

(2) Pulse train ratio 1 (basic para. 93)/Pulse train ratio 2 (basic para. 94)

Move amount of mechanical equipment system per 1 [pulse] of pulse train input can be converted to unit quantity using the command pulse correction and .

The scale factor ratio to the move amount of mechanical equipment system can also be changed, using the pulse train ratio 1 (27) and 2 (28) setting of the control input signals.

#### Basic parameter 93, 94

Para.	Name	Setting range	Initial value	Change
93	Pulse train ratio 1	0.01 to 100.00 (in 0.01 step)	1.00	Always
94	Pulse train ratio 2	0.01 to 100.00 (in 0.01 step)	10.00	Always

(3) Decimal point at position data (basic para. 95)

Decimal point can be displayed at the current position indication on the keypad panel by the basic para. 95 setting. Mechanical equipment system position can be checked by the numerical value with decimal point.

Basic parameter 95

Para.	Name	Setting range	Initial value	Change
95	Decimal point at position data	0 : 1 1 : 0.1 2 : 0.01 3 : 0.001 4 : 0.0001 5 : 0.00001	0	Always

5.3.3 Deviation clear

When this signal turns on, the difference (deviation) between current command position and current feedback position is cleared to zero.

Deviation clear (Control input signal)

Function

While this signal is on, the difference (deviation) is kept to zero.  
The deviation clear is valid during the on period of the speed zero [NZERO] signal.  
Current command position is assigned as current feedback position.

Parameter setting

To allocate the deviation clear signal to the control input terminal, set (50) to the system para..

Related items

All of the rotation commands are ignored, while the deviation clear signal is on.  
Even if the deviation clear is carried out, the current feedback position does not change.  
The remaining deviation due to the contact stoppage can be cleared to zero when the work is released, in order to avoid movement corresponding to the deviation quantity.  
When the deviation clear is carried out, the deviation zero signal of the control output is on.

5.3.4 Deviation zero

Check can be done that the motor is near the command position.

Deviation zero (Control output signal)

Function

This signal turns on, when the difference (deviation) between the current command position and current feedback position is within the value set by basic para. 53.  
The level of setting value of basic para. 53 has no relation with the positioning accuracy.  
Increasing the setting expedites outputting a deviation zero signal for stopping.

Parameter setting

To allocate the deviation zero signal to the control output terminal, set (23) to the system para..

Related item

Basic parameter 53

Para.	Name	Setting range	Initial value	Change
53	Deviation zero width	10 to 10000 [pulse] (in 1 step)	200	Always

Setting is made by encoder pulse count.

### 5.3.5 Deviation excessive [OF]

This function sets the deviation amount of deviation excessive (alarm detection) of amplifier.

Sets the pulse count for alarm detection about [OF]. Initial value at factory setting is 10000, and detects the deviation amount with 1000000 [pulse]. At factory setting, [OF] is detected, when the difference (deviation) between the current command position and current feedback position becomes approximately 15.2 [revolution] when converted to motor rotation.

Parameter setting

The deviation excessive width is setting for use with alarm detection, and cannot be assigned to control output terminal.

Related items

Basic parameter 54

Para.	Name	Setting range	Initial value	Change
54	Deviation excessive width	10 to 65535 (in 1 step) [x 100 pulse]	10000	Always

Setting is made by encoder pulse count (65536 [pulse/rev]).

### 5.3.6 Speed zero [NZERO]

This signal is turned on when the motor speed is near zero.

---

Speed zero [NZERO] (Control output signal)

---

Function

This signal turns on when the motor speed is below the value set by basic para. 52.

Parameter setting

To allocate the [NZERO] signal to the control output terminal, set (24) to the system para..

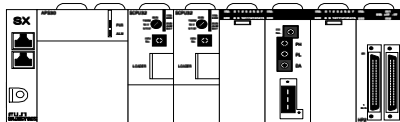

← Speed zero [NZERO]

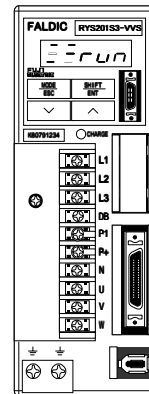

### 5.3.7 Speed arrive [NARV]

Check can be done that the motor rotation reaches the command speed.

---

Speed arrive [NARV] (Control output signal)

---

Function

This signal turns on, when motor speed reaches within setting value of basic para. 51 from the command speed. The command speed involves speed setting by para., speed data from positioning data and speed command voltage.

When control mode is shifted to torque control, the signal on/off status is retained at that point.

This signal will not be turned on for the following conditions:

- 1) Forward command [FWD] signal or reverse command [REV] signal is off.
- 2) When the motor speed does not reach the command speed due to the max. speed setting (basic para. 16).
- 3) Accel./decel. time is long and the speed does not reach the command speed.

#### Parameter setting

To allocate the speed arrive [NARV] signal to the control input terminal, set (25) to the system para.. If this signal is not allocated to the control input terminal, this signal is deemed "always off".

#### Related items

(1) Speed matching zone (width) (basic para. 51)

The [NARV] signal is turned on, when the motor speed is near the command speed (set by para.). As the initial value is 50 [r/min], the [NARV] signal is on when the motor speed reaches the command speed  $\pm 50$  [r/min].

When the motor speed does not reach the command speed due to the max. speed setting (basic. para. 16) or override setting, this signal turns off. When [FWD] or [REV] signal is off, the [NARV] signal does not turn on.

(2) Max. speed (basic para. 16)

This parameter specifies the max. value of motor speed.

If motor speed exceeds the max. speed by the override, the motor rotates at the setting value.

In the torque control mode, there is some 100 [r/min] difference between the setting value and the motor actual speed.

The setting of max. speed is not valid, during position control using pulse train input.

## 5.4 Origin return

The section explains origin return for determining a coordinate system and position preset.

Control input signal : • Origin return [ORG] (5)  
• Origin LS [LS] (6)  
• Position preset (16)

Control output signal : • Origin return end (22)  
• Origin LS detection (40)  
• Position preset end (75)

### 5.4.1 Origin return [ORG]

This function executes the origin return action and determines the origin.

---

Origin return [ORG] (Control input signal)

---

#### Function

This function executes the origin return action at the ON edge of [ORG] (5).

Origin return action depends on basic para. setting 72 to 77.

#### Parameter setting

To allocate the [ORG] signal to the control input terminal, set (5) to the system para..

#### Setting value to system parameter

Signal name	Setting value to system para.
Origin return [ORG]	5
Origin LS [LS]	6
Origin return end	22
Origin LS detection	40

Related items

(1) Parameter setting

Origin return action depends on basic para. setting.

Basic parameter 72 to 78

Para.	Name	Setting range	Initial value	Change
71	Origin return pattern	1 : Pattern 1, 2 : Pattern 2 3 : Pattern 3, 4 : Pattern 4	1	Power
72	Origin return direction	0 : Positive direction 1 : Negative direction	0	Power
73	Z-phase detection valid/invalid	0 : Valid 1 : Invalid	0	Power
74	Origin LS logic	0 : NO contact 1 : NC contact	0	Always
75	Origin return speed	0.01 to max. speed [r/min] (in 0.01 step)	500.00	Always
76	Origin detection creep speed	0.01 to max. speed [r/min] (in 0.01 step)	50.00	Always
77	Origin shift quantity	1 to 2000000 (in 1 step) [x unit q'ty]	5000	Always
78	Origin return reversing quantity	0 to 79999999 (in 1 step) [x unit q'ty]	0	Always
79	Origin return position	0 to $\pm$ 79999999 (in 1 step) [x unit q'ty]	0	Always

After the setting change of the basic para. 71 to 73, power supply need be turned on again.

(2) Origin return action

At the ON edge of [ORG] signal, the following operations are automatically carried out.

- (a) At the ON edge of [ORG] signal, motor rotation start at the origin return speed (basic para. 75) in the origin return direction (basic para. 72).
- (b) When the [LS] signal turns from off to on, speed is reduced to the origin detection creep speed (basic para. 76). While [LS] on, motor runs at constant speed.
- (c) The first Z-phase signal is detected, following the transfer point of [LS] signal from OFF edge to ON edge.
- (d) The motor stops after rotating by the origin shift quantity (basic para. 77) from the detection of Z-phase signal.
- (e) The positioning end [PSET] signal turns on, with the stopped position as the origin return end position (basic para. 79). The origin return end signal as the control output signal turns on.

An origin return action can be selected out of 4 patterns in the origin return pattern (basic para. 71).

With the Z-phase input invalid selected in the Z-phase valid/invalid (basic para. 73), motor can be stopped after running by the origin shift quantity from the ON edge to OFF edge of [LS] signal.

The on/off status of [LS] signal can be inverted using the origin LS logic (basic para. 74).

(3) Origin return pattern

Four kinds of origin return patterns are selectable from the basic para. 71 setting.

Comparison of origin return pattern

Origin return pattern	Setting range
Pattern 1	When the machine stop position is in the opposite direction to the origin return direction, the time required for origin return action can be shortened.
Pattern 2	When the machine stop position is in the origin return direction viewed from the origin LS, the time required for origin return action can be shortened (where it is near the OT signal in the return direction).
Pattern 3	When the machine stop position is just after the origin return direction viewed from the origin LS, the time required for origin return action can be shortened.
Pattern 4	When the machine stop position is in the opposite direction to the origin return direction, the detecting speed of origin LS is always constant even if the origin return speed is changed.

Origin return pattern 1 (setting value 1 in basic para. 71)

At the ON edge of [ORG] signal, the aforementioned operations (a) through (e) are carried out.

If the + direction overtravel [+OT] or - direction overtravel [-OT] signal of the origin return direction is detected during origin return action, the motor stops immediately. In this case, origin return is not ended. The origin return end signal still remains off.

The origin return action can be carried out again, regardless of the on/off status of the origin return end signal.

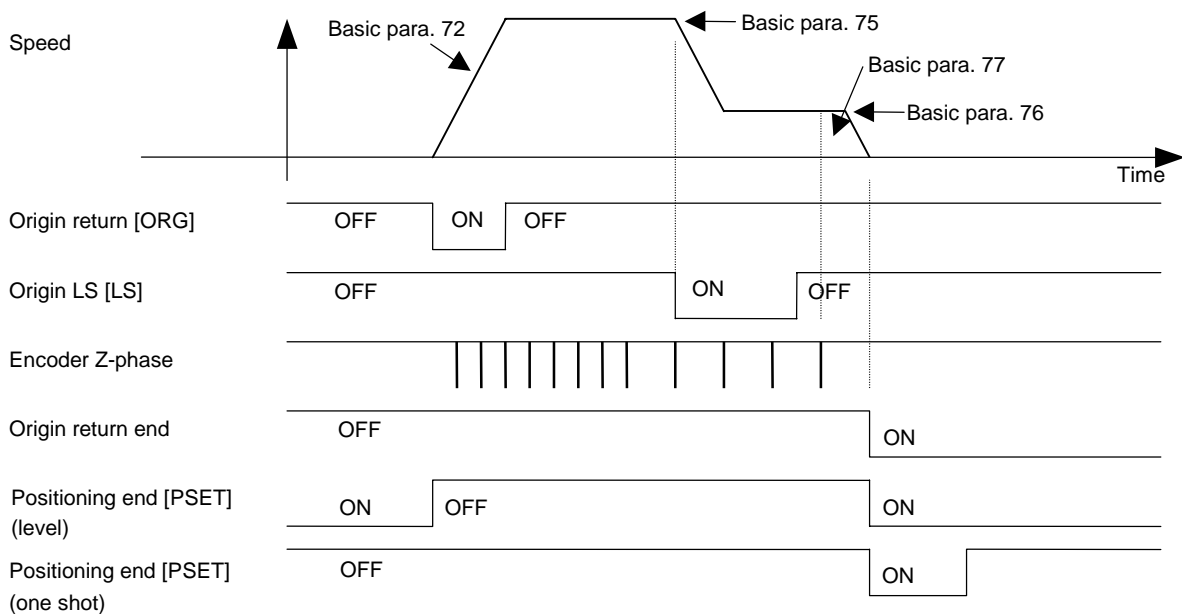

Origin return pattern 2 (setting value 2 in basic para. 71)

At the ON edge of [ORG] signal, the aforementioned operations (a) through (e) are carried out.

If the [+OT] or [-OT] signal in the origin return direction is detected in the action of origin return, the motor stops once. Then, the following operations are carried out.

- (f) The motor rotation start at the origin return speed in the opposite to the origin return direction.
- (g) The motor stops on detection of OFF level to ON level to OFF level transfer of the [LS] signal.
- (h) Operations (a) through (e) are carried out again.

In case the overtravel [OT] signal toward the opposite to the origin return direction is detected during (f) operation in the origin return action, the motor stops immediately ([LS] on level is not detected).

In this case, origin return action has not been ended.

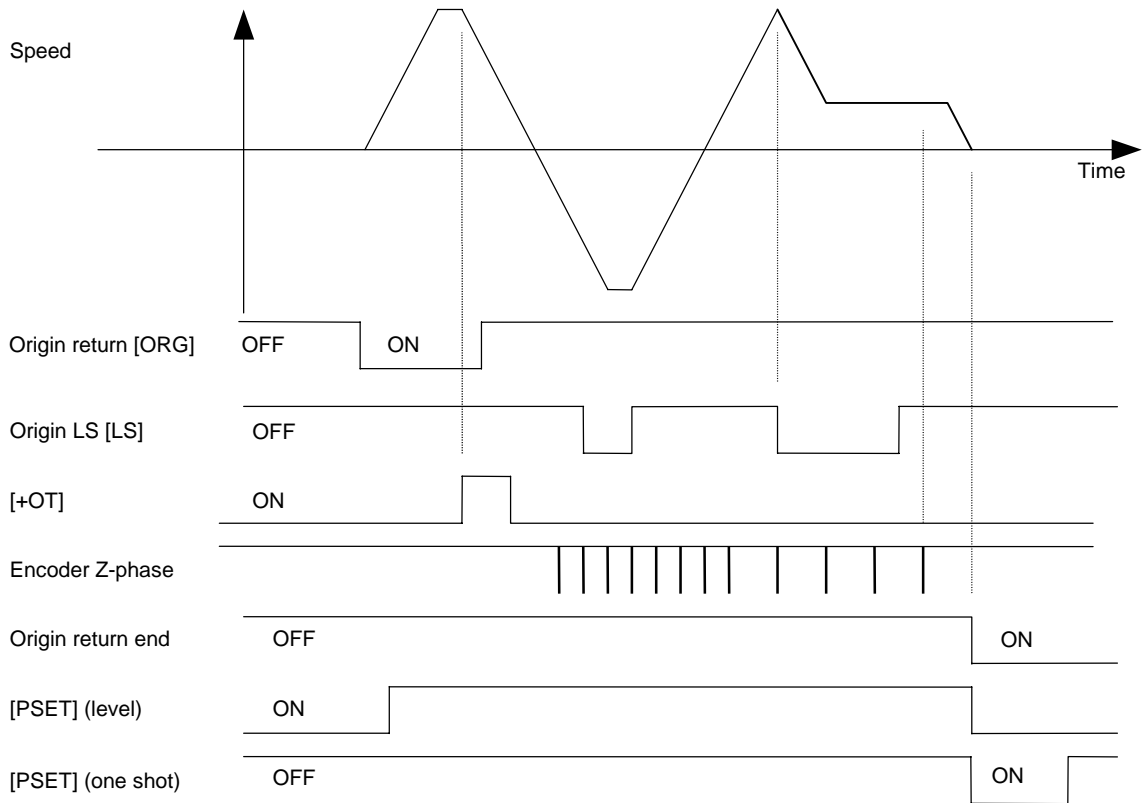

Origin return pattern 3 (setting value 3 in basic para. 71)

At the ON edge of [ORG] signal, the motor rotates by the origin return reversing quantity at the origin return speed. Then, the operation from (a) through (e) is carried out.

If the [OT] signal toward the opposite to the origin return direction is detected during rotation by the origin return reversing quantity, the movement stops once, and then carries out the origin return pattern 1.

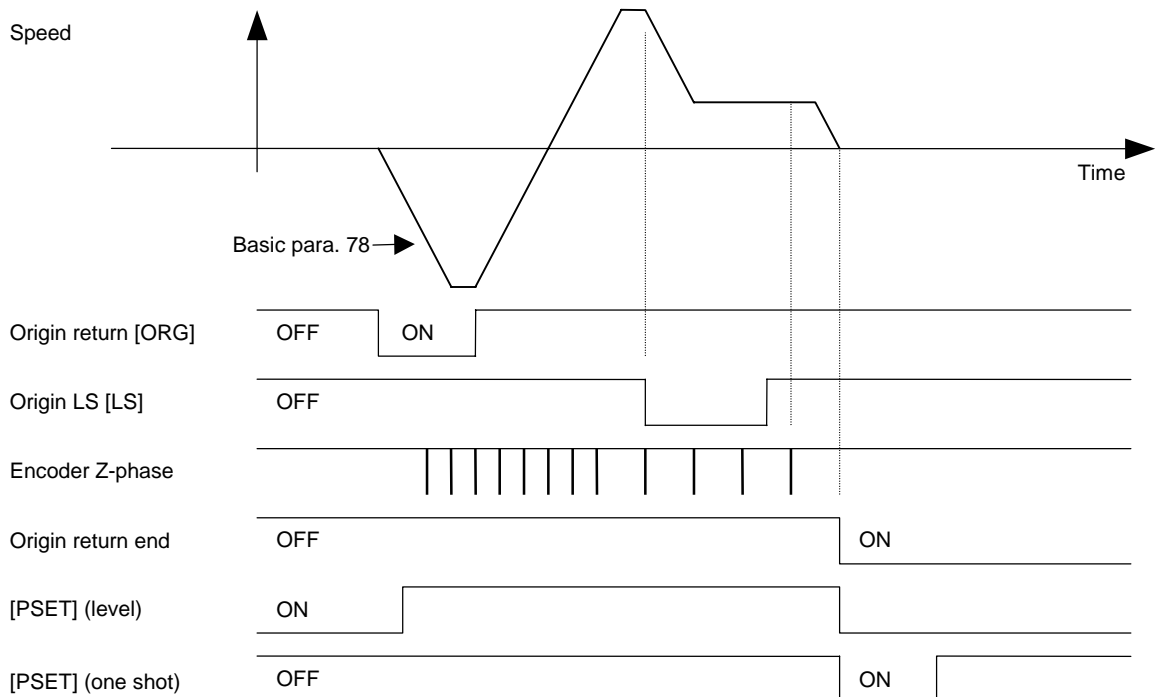

Origin return pattern 4 (setting value 4 in basic para. 71)

- (a) At the ON edge of [ORG] signal, motor rotation starts in the origin return direction at the origin return speed.
- (b) The movement stops once at the transfer point from ON level to OFF level of [LS] signal.
- (c) The motor rotates in the direction opposite to origin return at the origin detection creep speed.
- (d) The movement stops once at the transfer point from OFF to ON level of [LS] signal.
- (e) The motor rotates in the origin return direction at the origin detection creep speed.
- (f) After detecting again a transfer point (falling edge) from ON level to OFF level of [LS], the movement shifts by the origin shift quantity from the first Z-phase detection and then stops.
- (g) The stopped position is considered the origin return end position, and the origin return end signal is turned on.

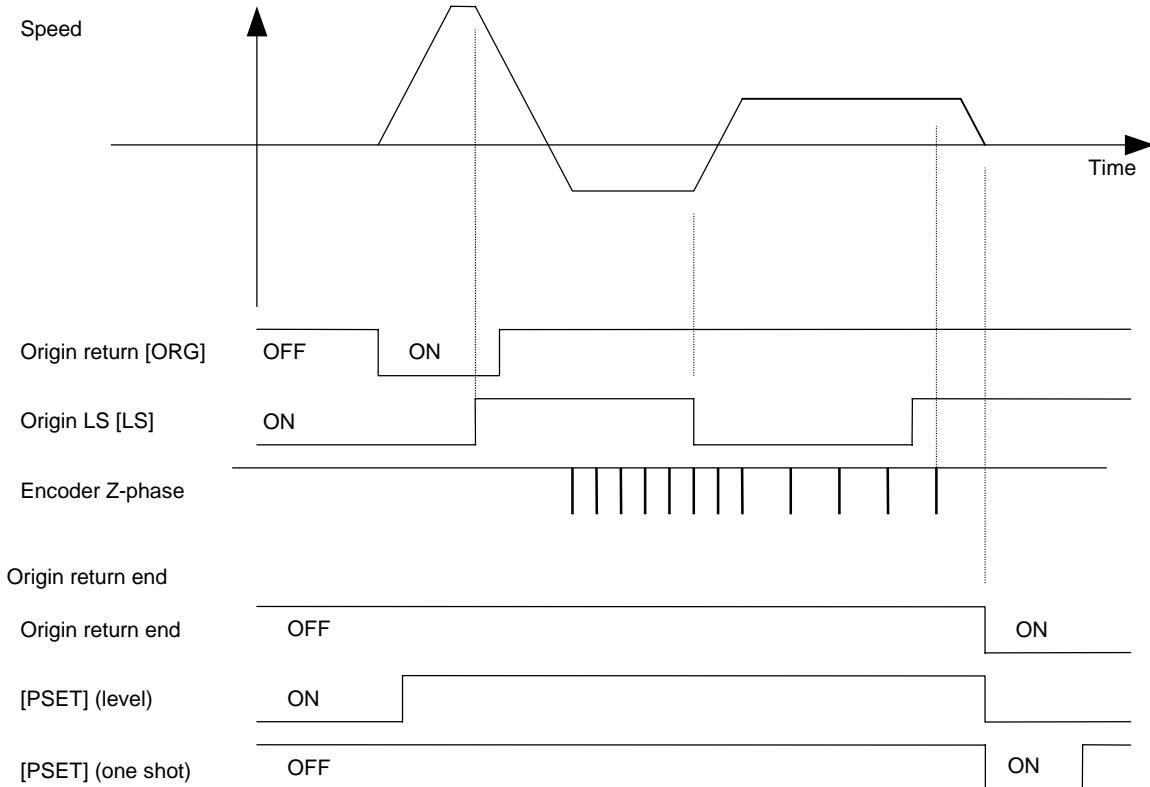

(4) Origin return end (22)

This signal is turned on, when the origin return action has been normally ended. After this, this signal is held on, when the current feedback position is within the origin detection range (basic para. 66) viewed from the origin return end position (basic para. 76). If the origin detection range is widened to the maximum, this signal is always on after the origin return end.

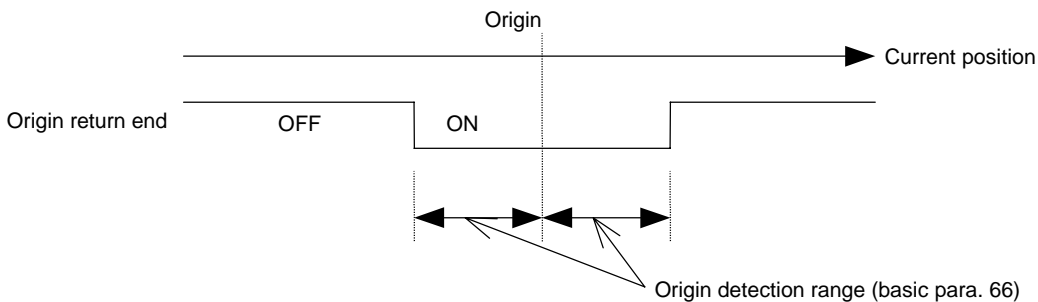

Note : The origin is the position where the machine has stopped after ended the origin return action, or has executed the position preset. It is not necessary the origin position: Where the current position is at zero position.

#### (5) Origin LS detection (40)

Because the [LS] signal requires quick response, this should be directly input to the amplifier in general. When the host controller needs the origin signal, the origin LS detection signal can be output.

While the [LS] signal is on, the origin LS detection signal (40) is on.

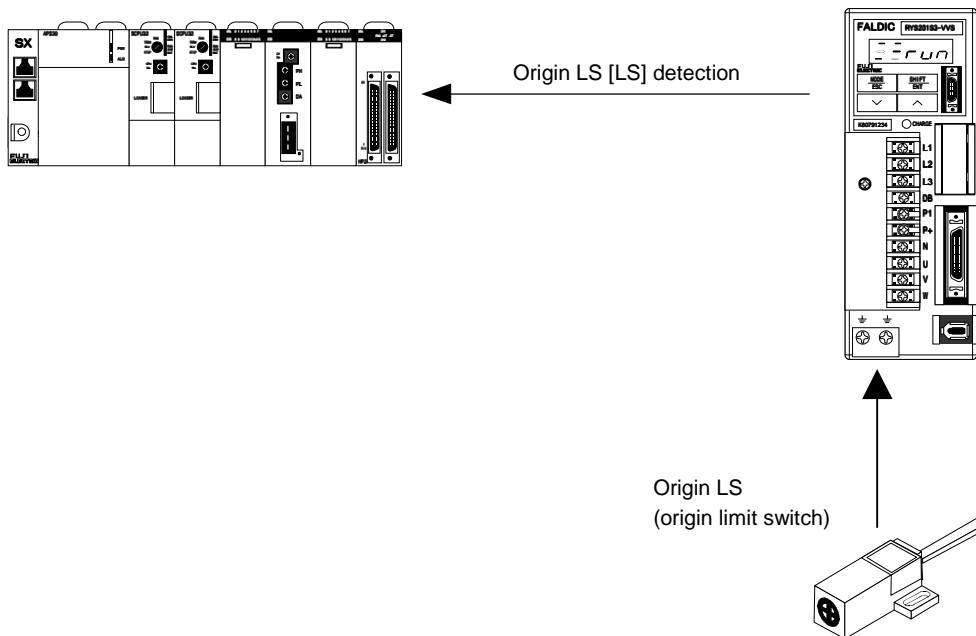

#### (6) LS-Z pulse

The encoder pulse count can be monitored, from the time when the [LS] signal goes to OFF level, until Z-phase signal is detected.

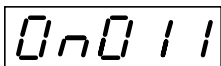

If this count is small, Z-phase signal of one rotation later may have been detected, depending on the origin LS response. In this case, move the mechanical position of the origin LS.

### 5.4.2 Position preset

When this signal turns on, the current command position can be rewritten.

---

Position preset (Control input signal)

---

#### Function

At the ON edge(\*) of this signal input, the current command position can be rewritten to the basic para. 80 setting. Position preset is executable while speed zero [NZERO] signal is on. The origin return end signal is output.

This signal can reset the following alarm detection:

- 1) ABS (absolute) data lost
- 2) Absolute data overflow [AF]

Note : (\*) ON edge means the control input signal's transfer point from off to on.

### Parameter setting

To allocate the position preset signal to the control input terminal, set (16) to the system para.. If this signal is not allocated to the control input terminal, this signal is deemed "always off".

### Related item

This signal can turn on the position preset end (75) signal.

When the position preset (16) turns on, the position preset end (75) is on, and when the position preset off, the position preset end off.

When the position presetting is not end, for example, if the speed zero is off, the position preset is not turned on.

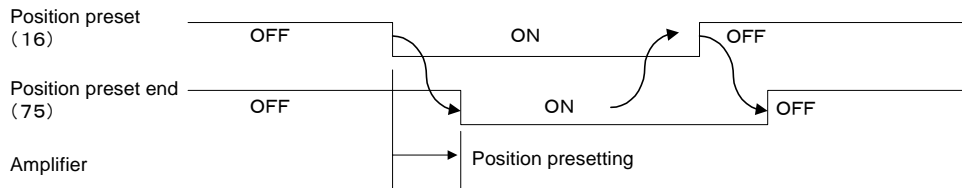

## 5.5 Auto start

The section explains signals relating to positioning action and signals relating to positioning data.

Control input signal : Auto start [START] (4)

Address [AD0] (fixed)

Address [AD1] (fixed)

Address [AD2] (fixed)

Address [AD3] (fixed)

Address [AD4] (fixed)

Address [AD5] (fixed)

Address [AD6] (fixed)

Address [AD7] (fixed)

Current position output command (56)

Control output signal : Positioning end [PSET] (2)

M code 0 (60)

M code 1 (61)

M code 2 (62)

M code 3 (63)

M code 4 (64)

M code 5 (65)

M code 6 (66)

M code 7 (67)

## 5.5 Auto start

The section explains signals relating to positioning action and positioning data.

Control input signal : Auto start [START] (4)

Address [AD0 to AD7] (fixed)

Current position output (56)

Control output signal : Positioning end [PSET] (2)

M code 0 to 7 (60 to 67)

Remark : For SX bus type (SX bus direct connection), addresses, M codes, and current positions can be obtained from IQ area.

For T-link type (T-link direct connection), addresses, M codes, and current positions can be obtained from WB area.

For RS485 interface, addresses, M codes, and current positions can be obtained from command.

The auto start [START] (4) signal needs to be commanded by on/off of bit.

### 5.5.1 Auto start [START]

The signal starts a positioning action.

#### Auto start [START] (Control input signal)

##### Function

A positioning action starts at the ON edge of [START] (4) signal. Numbers of positioning data to execute are assigned to addresses [AD7 to AD0].

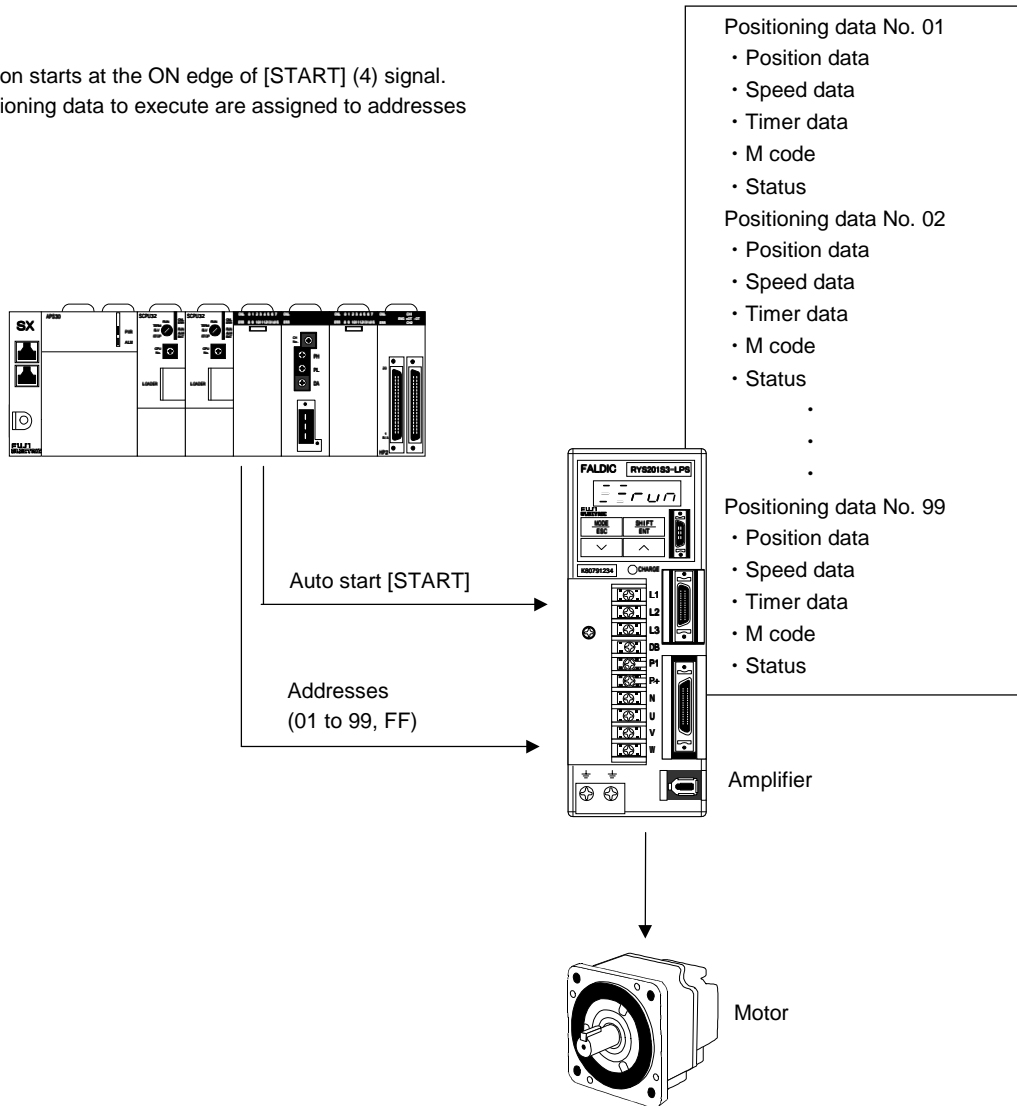

##### Parameter setting

To allocate the [START] signal to the control input terminal, set (4) to the system para..  
 If these signals are not allocated to the control input terminal, these signals are deemed "always off".

Related items

(1) Specifying address (AD7 to AD0)

The address (positioning data number) is settled at the ON edge of auto start [START] signal.

Address (positioning data number)	
Amplifier	Address
Basic type (DI/DO position)	BCD code or binary can be changed over.
SX bus type (SX bus direct connection)	Only binary can be specified.
T-link type (T-link direct connection)	BCD code or binary can be changed over.
RS485 interface	Only binary can be specified.

In case of BCD code, AD7 to AD4 specify the value at ten's digit of data number, and AD3 to AD0 specify the value at unit's digit of data number.

Specifying the address (10's digit of BCD)

AD7	AD6	AD5	AD4	10's digit
OFF	OFF	OFF	OFF	0
OFF	OFF	OFF	ON	1
OFF	OFF	ON	OFF	2
OFF	OFF	ON	ON	3
OFF	ON	OFF	OFF	4
OFF	ON	OFF	ON	5
OFF	ON	ON	OFF	6
OFF	ON	ON	ON	7
ON	OFF	OFF	OFF	8
ON	OFF	OFF	ON	9

Specifying the address (Unit's digit of BCD)

AD3	AD2	AD1	AD0	Unit's digit
OFF	OFF	OFF	OFF	0
OFF	OFF	OFF	ON	1
OFF	OFF	ON	OFF	2
OFF	OFF	ON	ON	3
OFF	ON	OFF	OFF	4
OFF	ON	OFF	ON	5
OFF	ON	ON	OFF	6
OFF	ON	ON	ON	7
ON	OFF	OFF	OFF	8
ON	OFF	OFF	ON	9

In case of binary code, AD6 to AD0 specify the value.

Specifying the address (binary)

AD6	AD5	AD4	AD3	AD2	AD1	AD0	Address No.
OFF	OFF	OFF	OFF	OFF	OFF	ON	1 (01H)
OFF	OFF	OFF	OFF	OFF	ON	OFF	2 (02H)
OFF	OFF	OFF	OFF	OFF	ON	ON	3 (03H)
OFF	OFF	OFF	OFF	ON	OFF	OFF	4 (04H)
OFF	OFF	OFF	OFF	ON	OFF	ON	5 (05H)
OFF	OFF	OFF	OFF	ON	ON	OFF	6 (06H)
OFF	OFF	OFF	OFF	ON	ON	ON	7 (07H)
OFF	OFF	OFF	ON	OFF	OFF	OFF	8 (08H)
OFF	OFF	OFF	ON	OFF	OFF	ON	9 (09H)
OFF	OFF	OFF	ON	OFF	ON	OFF	10 (0AH)
ON	ON	OFF	OFF	OFF	ON	OFF	98 (62H)
ON	ON	OFF	OFF	OFF	ON	ON	99 (63H)

### Time chart for auto start signal

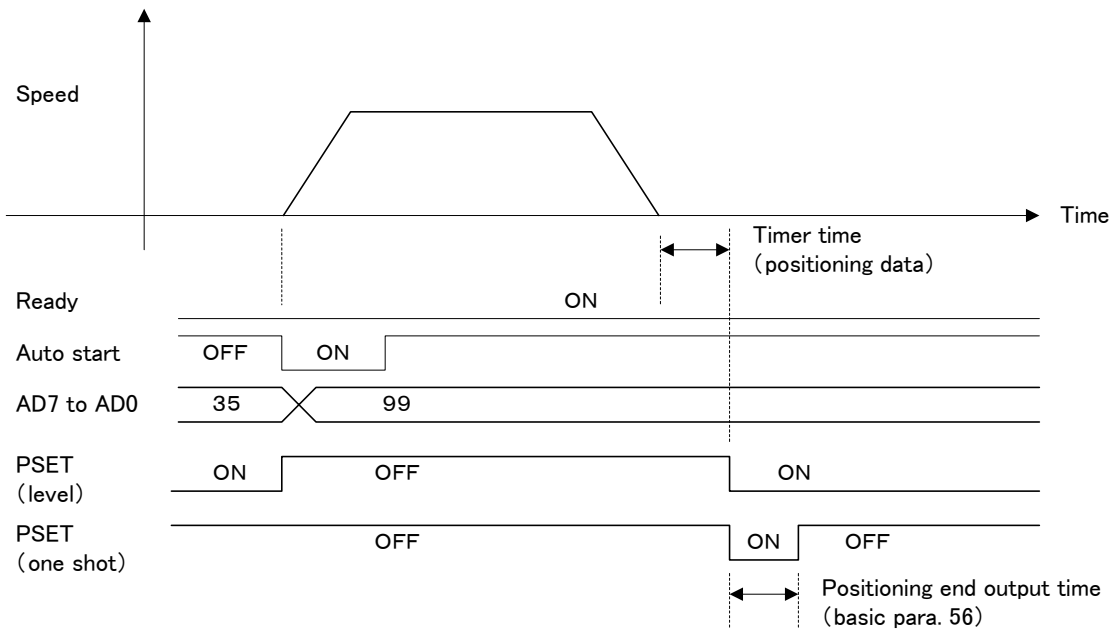

The positioning data number may be changed when the positioning end [PSET] signal has turned off.  
 The positioning data number is settled at the ON edge [START] signal.  
 The output mode of [PSET] signal is selected by basic para. 55.

#### (2) Backlash correct

The backlash of mechanical equipment system can be corrected by move amount of the motor shaft.

#### Basic parameter 86

Para.	Name	Setting range	Initial value	Change
86	Backlash correct	0 to 10000 [pulse] (in 1 steps)	0	Always

The rotational direction of motor, the motor rotates by the amount added by the setting value.  
 The movement corresponding to the backlash correction in progress does not affect the current position display.

(3) Sequential starting

Positioning data at an arbitrary address to positioning data where the status is set at "CEND" are sequentially executed by auto start signal only.

A movement starts at the ON edge of auto start signal.



The execution procedure of sequential starting is as follows.

- Specify the first positioning data number and apply an auto start signal (No. 17 in above figure).  
According to the setting of positioning data No. 17, the motor shaft rotates.
- If an auto start signal is applied upon specifying the address "00" (all OFF), the motor shaft rotates according to the next positioning data (No. 18 in above figure).
- The action in (b) is repeated up to the positioning data where cycle end [CEND] is set.
- After the end of positioning action at the positioning data where [CEND] is set, a [CEND] signal is outputted concurrently with the positioning end signal. ([CEND] signal is OUT assign signal.)
- Turning on the auto start signal again leaving the address at "00" repeats the steps (a) to (d).

**Time chart for sequential start**

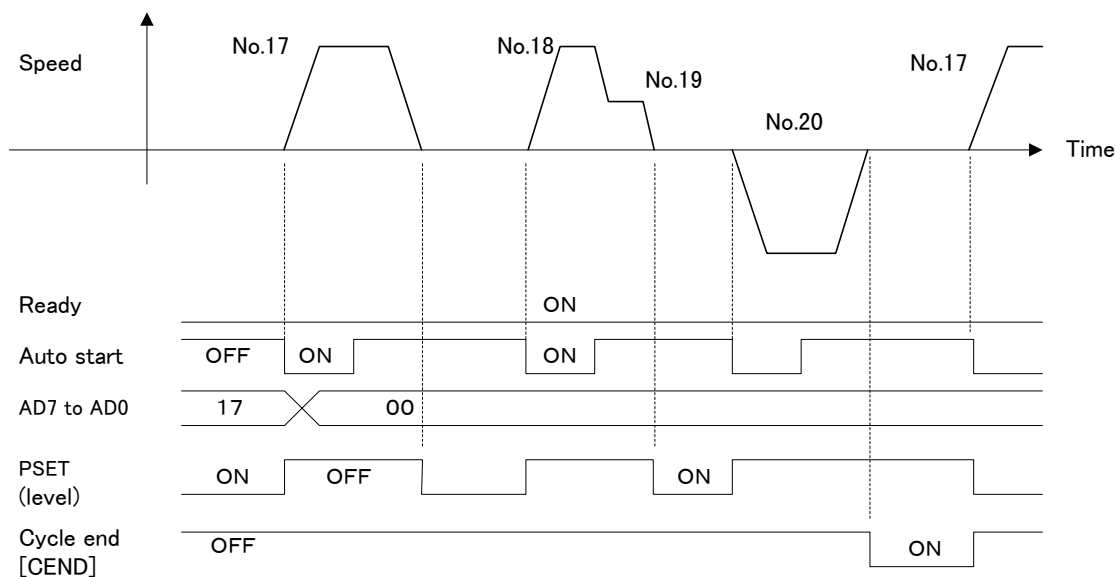

Remarks : The cycle end signal is not outputted if the sequential start cannot be executed in the following cases.

- Run command [RUN] off, forced stop [EMG] off and ready [RDY] off
- While in sequential starting, movement has been made by manual running, origin return or pulse train input.
- +OT, -OT or soft OT is detected.

Positioning cancel or temporary stop does not affect the sequential start.

Cycle end processing is made when the sequential start has reached the positioning data 99 (when [CEND] is not specified).

In case a data continuation is specified, the sequential start starts at the positioning data following the last data where a continuation is not specified.

### 5.5.2 Positioning end [ PSET ]

The completion of positioning can be checked by this signal on.

---

Positioning end [PSET] (Control output signal)

---

#### Function

The signal turn on, when the positioning action is ended. The signal off, when the motor shaft starts rotation. The signal can not turned on, while the motor stops by the temporary stop (31).

The output form of [PSET] signal can be selected by setting basic para. 55.

#### Parameter setting

To allocate the [PSET] signal to the control output terminal, set (2) to the system para..

Related items

(1) Output form of [PSET] signal

Output form of [PSET] signal is selectable by setting of basic para. 55 and 56.

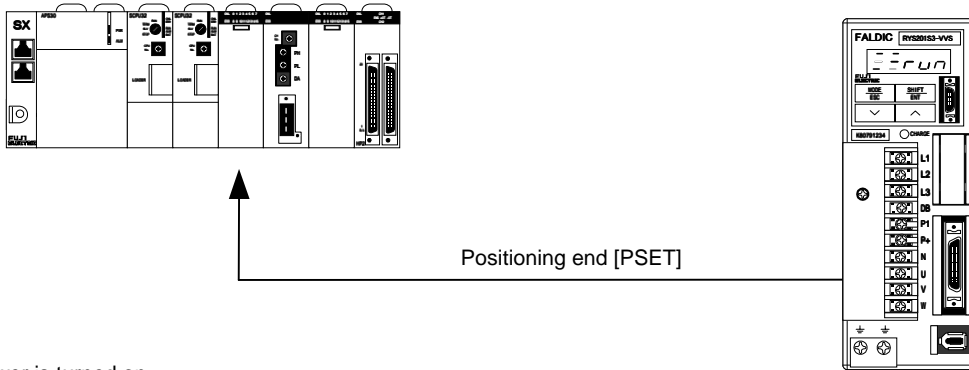

1) When power is turned on

Level : ON

One shot : OFF. Automatically turns off, after the elapsed time set by basic para. 56 has elapsed. So it turns on for about 1.5 [s] in order to check function.

2) Pulse train

Level : Turns on when the difference (deviation) between command position (pulse train input) and feedback position is within the deviation zero width (basic para. 53). For the pulse train input, the form of output signal is same as that of deviation zero signal.

One shot : Turns on for the specified period of time, when the deviation quantity is within the deviation zero width (basic para. 56).

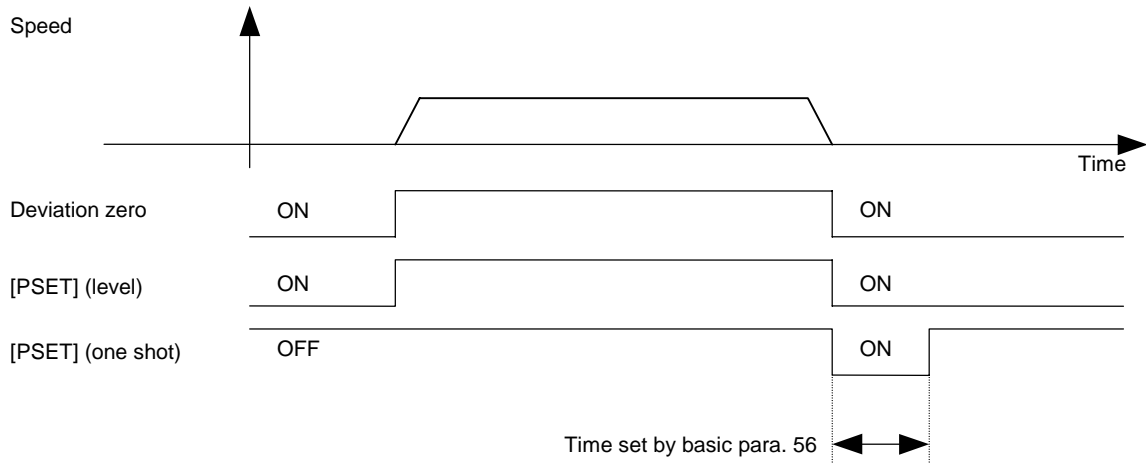

With one shot selected, when deviation zero signal is off within the time set by basic para. 56, operation is stopped forcibly.

3) Interrupt positioning

Level : Turns on when the positioning end judgment time (basic para. 57) has elapsed, after the difference (deviation) between the command position and feedback position came within the deviation zero width (basic para. 53).

One shot : Turns on for the determined period of time (basic para. 56) on condition that the positioning end level is on.

With one shot selected, when positioning has started within the time set by basic para. 56, operation is stopped forcibly.

4) Origin return/auto start

Level : Turns on when the positioning end judgment time (basic para. 57) has elapsed, after the difference (deviation) between the command position and feedback position came within the deviation zero width (basic para. 53).

One shot : Turns on for the determined period of time (basic para. 56) on condition that the positioning end level is on.

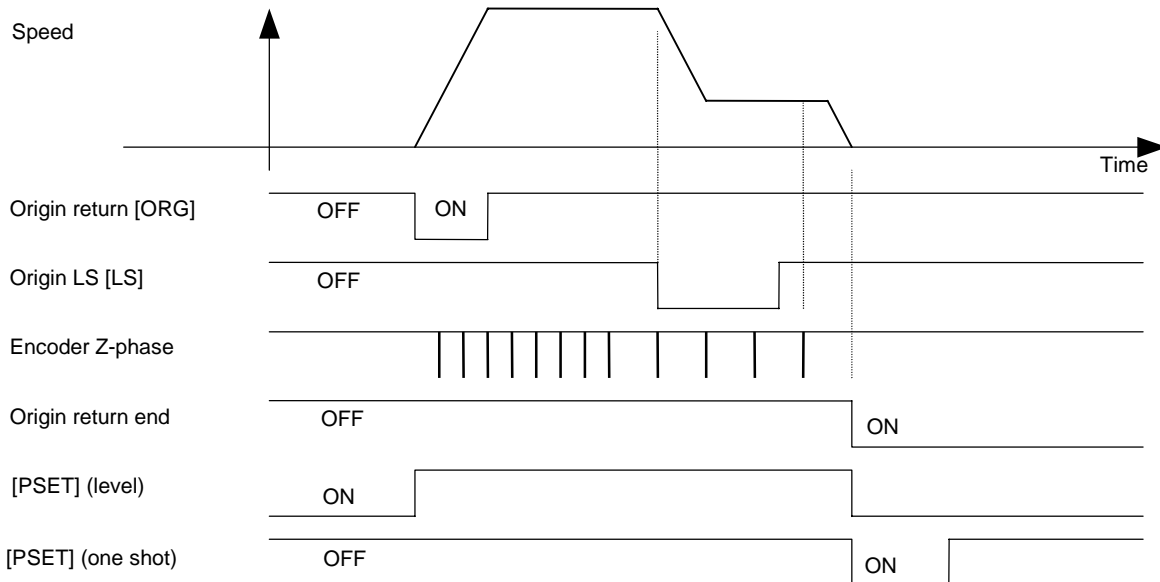

With one shot selected, when positioning has started within the time set by basic para. 56, operation is stopped forcibly.

(2) Positioning end judgment time

The output timing of [PSET] signal is shown below.

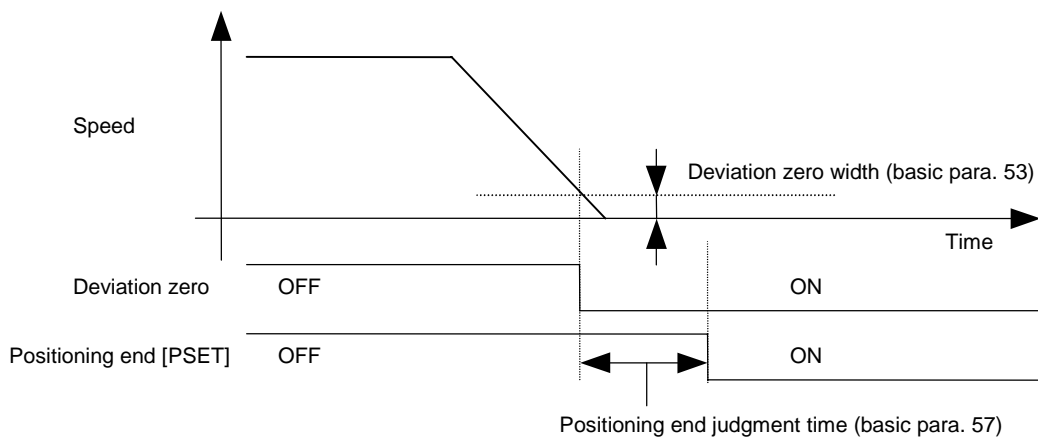

- 1) The command current position reaches the target position.
- 2) The motor's current feedback position follows the current command position to reach the target position.
- 3) When the difference (deviation) between the current command position and the current feedback position is less than the deviation zero width (basic para. 53), the deviation zero signal is turned on.

When the deviation zero signal is continuously held on during the positioning end judgment time (basic para. 57), the [PSET] signal is turned on. Speed zero [NZERO] signal on is needed.

(3) [PSET] output at alarm detection

Cause	Deceleration method (*)	Positioning end [PSET]	Remark
Run command [RUN] off	“Forced zero speed” to “base off”	On at stopping	Ready [RDY] off
Forced stop [EMG] off	Forced zero speed	Off	On at forced stop [EMG] release
+OT, -OT detection Soft OT detection	“Forced zero speed” to “ servo lock”	On at stopping	Rotatable when pulse train input, forward command or reverse command on
Alarm detection [ALM] (minor fault) (*)	“Forced zero speed” to “base off”	Off at stopping	Turns on when reset by alarm reset [RST]
Alarm detection [ALM] (major fault) (*)	Base off	Off at stopping	Turns on when reset by alarm reset [RST]

(\*) : Minor fault : Deviation excessive [OF], braking resistor overheat [rH], amplifier overheat [AH], encoder overheat [EH] and bus communication error [tE]

Major fault : Alarm detection other than minor fault

Forced zero speed : Decelerates to a stop rapidly.

Base off : Motor has no driving force (free-run)

### 5.5.3 Immediate positioning

The motor is positioned upon directly specifying its stop position from PLC, etc.

---

Auto start [START] (Control input signal)

---

#### Function

Set the "FF" to address and apply [START] signal to start a positioning action.

- Basic type (DI/DO position)

Using immediate rewrite (39), immediate data selection 0 (40) or immediate data selection 1 (41), 32 bit position data can be written via address [AD0 to AD7] in the amplifier.

- SX bus type (SX bus direct connection)

Position data can be written, into 8, 9 word position of IQ area.

If VEL0 (12), VEL1 (13) are not allocated, speed data can be written into 11, 11 word.

- T-link type (T-link direct connection)

Position data can be written into +7, +8 word position into WB area.

- RS485 interface

There are CM : 34, SCM : 39 command terminals for immediate starting.

There are CM : 34, SCM : 37 command terminals for immediate data setting.

#### Auto start (immediate positioning)

Amplifier	Setting of position data
Basic type (DI/DO position)	Writes the data of divided position.
SX bus type (SX bus direct connection)	Writes the data of the specified and the speed into IQ area.
T-link type (T-link direct connection)	Writes the data of the specified into WB area.
RS485 interface	Writes the position data by operation command.

**Parameter setting**

To allocate immediate rewrite to control input terminal, set (39) to the system para.. Set (40) for immediate data selection 0, or (41) for immediate data selection 1.

Unless these signals are allocated to the control input terminal, they are deemed "always off".

**Related items**

(1) Immediate rewrite (DI/DO position)

**Related items**

The following shows a write sequence for position data (immediate data). It is written by groups of 8 bit via [AD0 to AD7].

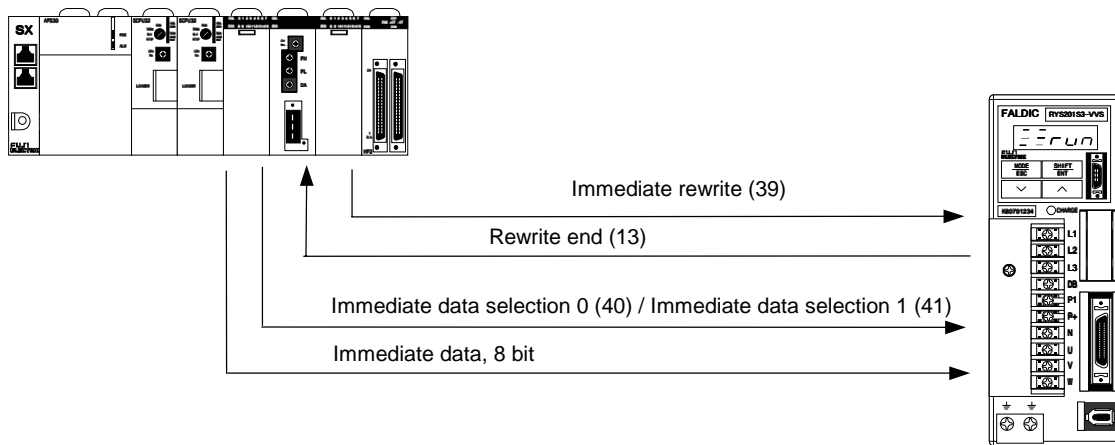

**Immediate rewrite sequence**

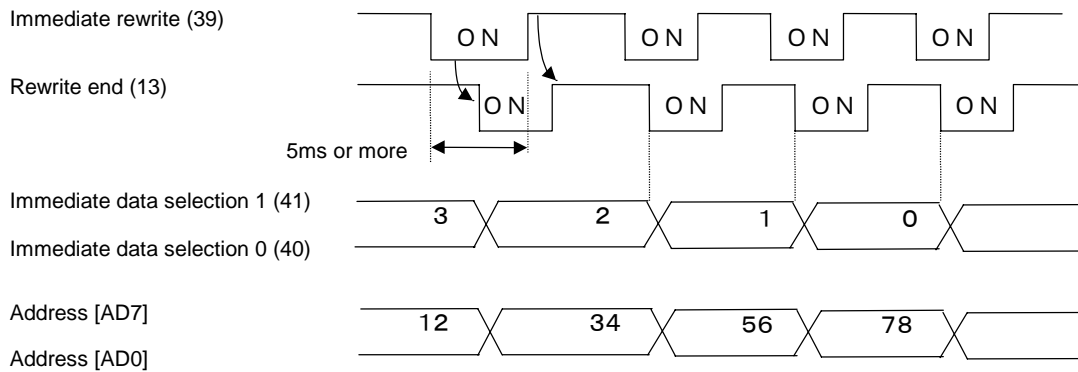

- 1) Select which to rewrite by turning on/off the immediate data selections 1 and 0.
- 2) Prepare data of 8 bit to rewrite with in AD7 to AD0.
- 3) Turning on immediate rewrite (39) rewrites the range selected by immediate data selections 0 and 1.  
OUT assign rewrite end (13) turns on.  
When a rewrite end signal has turned on, immediate data selections 0 and 1 may be changed.
- 4) Turning off the immediate rewrite (39) also turns off the rewrite end (13).
- 5) Execute the above steps 1) to 4) as many cycles as required.
- 6) Set the "FF" to address (AD7 to AD0) and apply an auto start signal to start a positioning action.

Immediate data can be rewritten any time regardless of the amplifier status. In the above example, 12345678 are written. See 12.2 for programming example.

### Immediate data selection 1/0

Immediate data selection 1/0

Immediate data selection 1	Immediate data selection 0	Rewritten object
OFF	OFF	Lowest order 8 bit
OFF	ON	Lower order 8 bit
ON	OFF	Higher order 8 bit
ON	ON	Highest order 8 bit

Highest order 8 bit		Higher order 8 bit		Lower order 8 bit		Lowest order 8 bit	
---------------------	--	--------------------	--	-------------------	--	--------------------	--

Binary code

Highest order 8 bit		Higher order 8 bit		Lower order 8 bit		Lowest order 8 bit	
---------------------	--	--------------------	--	-------------------	--	--------------------	--

BCD code  
(MSB (\*) is sign)

10<sup>7</sup> 10<sup>6</sup> 10<sup>5</sup> 10<sup>4</sup> 10<sup>3</sup> 10<sup>2</sup> 10<sup>1</sup> 10<sup>0</sup>

Following signals are used for motor starts rotation with [START] signal on.

Speed data : Unless assigned, setting of para. 8 is retained.

VEL1 (13)	VEL0 (12)	Positioning speed
OFF	OFF	Basic para. 8
OFF	ON	Basic para. 9
ON	OFF	Basic para. 10
ON	ON	Basic para. 11

Acceleration/deceleration time : Unless assigned, setting of paras. 21 and 22 is retained.

ACC0 (14)	Acceleration time	Deceleration time
OFF	Basic para. 21	Basic para. 22
ON	Basic para. 23	Basic para. 24

ABS / INC : Unless assigned, the absolute position is specified.

ABS / INC (9)	Immediate data
OFF	ABS (absolute position specified)
ON	INC (relative position specified)

Executing the positioning

START (4)	AD7 to AD0	Positioning
ON edge	01 to 99	Positioning data
	FF	Immediate data

Note (\*) : MSB: Highest order bit

(2) Recommended setting when using the immediate positioning

System parameter of RYS-L type			Basic type (DI/DO position)	
Para.	Name	Setting range	Initial value	Change
01	CONT1 signal assignment	0 to 56 (in 1 step)	1	Power
02	CONT2 signal assignment	0 to 56 (in 1 step)	2	Power
03	CONT3 signal assignment	0 to 56 (in 1 step)	3	Power
04	CONT4 signal assignment	0 to 56 (in 1 step)	11	Power
05	CONT5 signal assignment	0 to 56 (in 1 step)	4	Power
06	CONT6 signal assignment	0 to 56 (in 1 step)	5	Power
07	CONT7 signal assignment	0 to 56 (in 1 step)	39	Power
08	CONT8 signal assignment	0 to 56 (in 1 step)	40	Power
09	CONT9 signal assignment	0 to 56 (in 1 step)	41	Power
10	CONT10 signal assignment	0 to 56 (in 1 step)	6	Power
11	CONT11 signal assignment	0 to 56 (in 1 step)	7	Power
12	CONT12 signal assignment	0 to 56 (in 1 step)	8	Power
13	CONT13 signal assignment	0 to 56 (in 1 step)	10	Power
31	OUT1 signal assignment	0 to 67 (in 1 step)	1	Power
32	OUT2 signal assignment	0 to 67 (in 1 step)	2	Power
33	OUT3 signal assignment	0 to 67 (in 1 step)	30	Power
34	OUT4 signal assignment	0 to 67 (in 1 step)	31	Power
35	OUT5 signal assignment	0 to 67 (in 1 step)	0	Power
36	OUT6 signal assignment	0 to 67 (in 1 step)	0	Power
37	OUT7 signal assignment	0 to 67 (in 1 step)	0	Power
38	OUT8 signal assignment	0 to 67 (in 1 step)	0	Power
39	OUT9 signal assignment	0 to 67 (in 1 step)	0	Power
40	OUT10 signal assignment	0 to 67 (in 1 step)	13	Power
87	CONT always valid 1	0 to 56 (in 1 step)	51	Power
88	CONT always valid 2	0 to 56 (in 1 step)	0	Power

Shaded paras. at  have been changed from factory setting.

- Manual operation - Manual feed speed 2 is valid (set by basic para. 2).
- Origin return - Selectable out of 4 patterns.
- Auto start - Operation is according to immediate positioning and positioning data.
- Incidental functions - +OT, -OT, forced stop.

#### 5.5.4 Current position output

Command is inputted for the current position output.

---

Current position output command (Control output signal)

---

##### Function

The current position output command signal value is a signal of unit quantity set by basic para. 91 and 92. Actual move amount of mechanical equipment system is transmitted based on an origin point. When pulse correction function is not used, the current position is represented by the rotational quantity (accumulated absolute position) where 1 [revolution] of motor is divided by 65536 [pulses/rev].

##### Basic type (DI/DO position)

Current position is transmitted from the control output terminal with on/off of current position output (56). Current position can be obtained at the time of power on.

· SX bus type (SX bus direct connection)

The current position can be outputted to the 0, 1 word position of IQ area. The current position can be outputted on condition that bit of SEL2, SEL1, and SEL0 are all off.

The current position can be obtained with the refresh cycle of IQ area.

· T-link (T-link direct connection)

The current position can be outputted to the +0, +1 word position of WB area. The current position can be outputted on condition that 5 bit of data selection are all off.

The current position can be obtained with the refresh cycle of T-link.

RS485 interface

Current command can be obtained with the write command (CM : 30, SCM : 30) of monitor data.

#### Current position output

Amplifier	Current position output
Basic type (DI/DO position)	Current divided position can be outputted.
SX bus type (SX bus direct connection)	Current position can be outputted to IQ area.
T-link type (T-link direct connection)	Current position can be outputted to WB area.
RS485 interface	Current position can be outputted as monitor data.

#### Parameter setting

To allocate the current position output to the control input terminal, set (56) to the system para.. If this signal is not allocated to the control input terminal, this signal is deemed "always off".

#### Related item

(1) Transmission format : Basic type (DI/DO position)

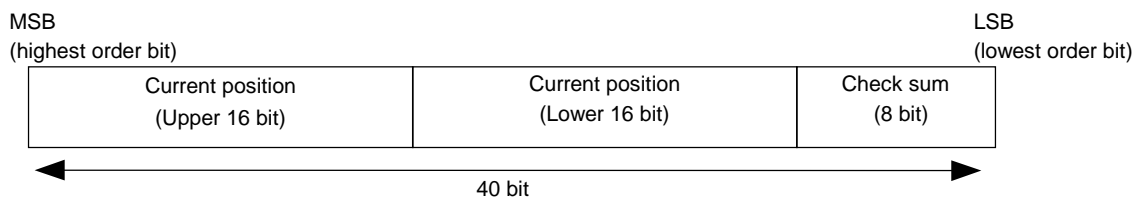

Current position : Transmitted in 32 bit binary data, beginning with MSB.

Check sum : Resultant lower 8 bit when 1 byte (8 bit) data is added 4 times from MSB side. Check sum is transmitted, beginning with MSB side as well. Check sum is done for the current position 32 bit length data.

#### Remarks :

Motor position detector (16 bit serial encoder) consists of one rotation data and multiple rotation data. This is different from the current position output data transmitted from amplifier.

1) Multiple rotation data

Rotational quantity per one rotation based on the origin of motor (encoder).

The data is complement of 2 in 16 bit and from -32768 to +32767.

2) One rotation data

Absolute position within motor (encoder) one rotation.

16 bit data and 0 to 65535.

Current position (P) is expressed as  $P = (65536 \times M) + B$

Where

M : Multiple rotation data

B : One rotation data

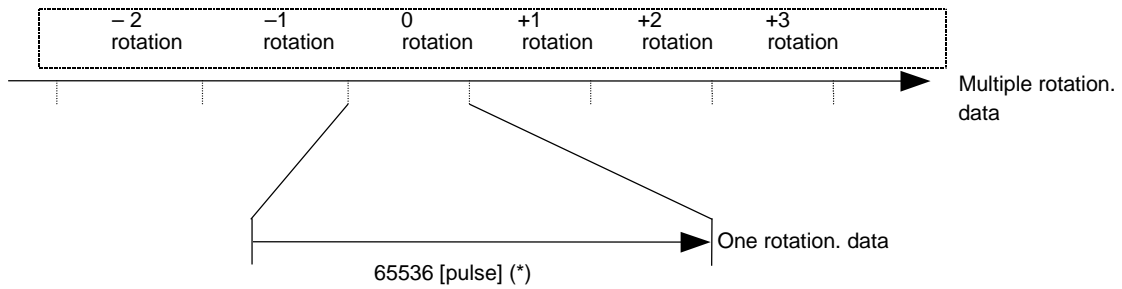

(\*) The position of position preset or origin return end is within this zone.

(2) Output sequence

The sequence of current position output is explained as below. Output is in 2-bit unit.

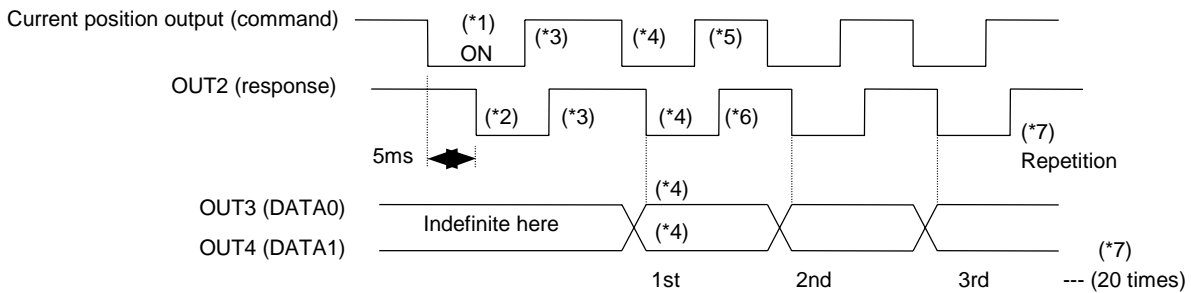
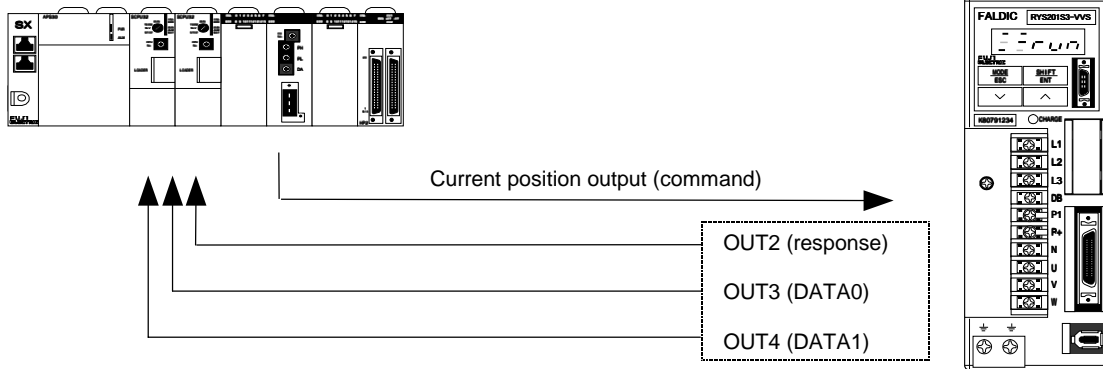

- (\*1) Makes the current position output (command) on for 5 [ms] or longer. The current position output sequence starts.
- (\*2) OUT2 (response) turns on.
- (\*3) Makes the current position output (command) off. OUT2 (response) turns off.
- (\*4) Makes the current position output (command) on. When OUT3 (DATA0) and OUT4 (DATA1) are established, OUT2 (response) turns on.
- (\*5) When OUT3 (DATA0) and OUT4 (DATA1) are recognized, makes current position output (command) off.
- (\*6) OUT2 (response) turns off.
- (\*7) Steps (\*4) to (\*6) are repeated the remained 19 times. When OUT2 (response) turns off at the 19th times, terminals OUT3 and OUT4 output the control output signals preset beforehand.

Current position output (command) and OUT2 (response) are interlocked in ON/OFF level.

If on period of current position output (command) is too long, current position output sequence does not proceed.

Data transmission or receiving cannot be stopped without completing sequence. And the current position output sequence terminates forcibly in 5 [s].

Current position output (command) is always valid. While the motor is rotating, the current position is transferred at the first ON edge of current position output (command).

Because the function of terminal OUT2, OUT3 and OUT4 is forcibly changed, do not make the current position output (command) turning on while the run command [RUN] is on.

The last 8 bit of the 40 bit data of current position output is for check sum. This is the resultant lower 8 bit after each 8 bit in the current position 32 bit data is added. Make sure that the addition data executed by the host controller is same as the transmitted data.

Terminal OUT 4 [DATA1] outputs 2 bit data on MSB side.

See 12.2 Example of program.

### 5.5.5 M code

M code is outputted according to setting contents of positioning data being executed.

---

M code (Control output signal)

---

#### Function

M code, is outputted in accordance with the setting of positioning data.

M00, M02, M30, M98 and M99 have no specific functions and all are general-purpose code outputs. There is no interlock function by M<sub>ON</sub> and M<sub>OFF</sub>.

M code can be set to 00h to FFh in hexadecimal number.

- Basic type (DI/DO position)

M code is outputted from the M code 7 (67) to M code 0 (60). Setting to system para. is needed.

- SX bus type (SX bus direct connection)

M code is outputted to 5 word position (lower order 8 bit) into IQ area. Setting to system para. is not needed.

- T-link type (T-link direct connection)

M code can be checked with allocation the M code 7 (67) to M code 0 (60) into WB area. Setting to system para. is needed.

- General-purpose communication (RS485 interface)

M code can be obtained with write command (CM : 30, SCM : 31) of the positioning data being executed.

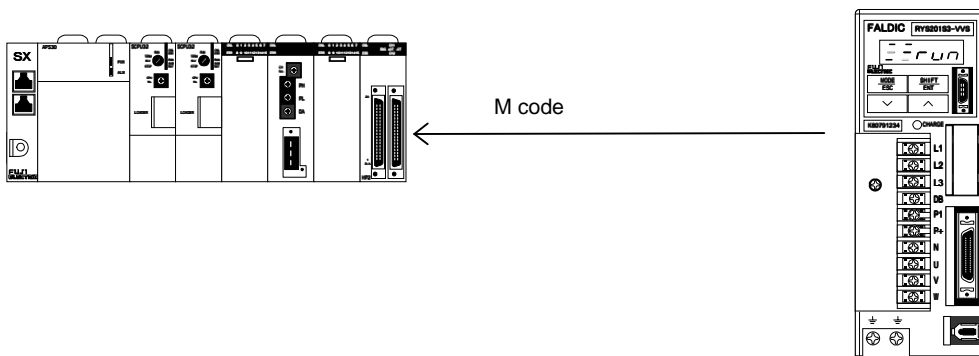

Parameter setting

To allocate M code 7 to M code 0 to the control output terminals, set (67) to (60) to the system para.

Related items

(1) Setting range of M code

M code can be set to 00h to FFh in binary.

It is set in binary regardless of setting of system para. 98. In the case of SX bus type, binary setting is only valid.

(2) Simultaneous output [MW] and later-output [MA] (\*)

You can select either "simultaneous output" being outputted while executing the positioning data, or "later-output" outputted after the end of execution of positioning data.

Simultaneous output [MW]

[MW] is outputted while executing from starting to ending of positioning action. [MW] is turned off, when ended the positioning action.

**Simultaneous output [MW] of M code**

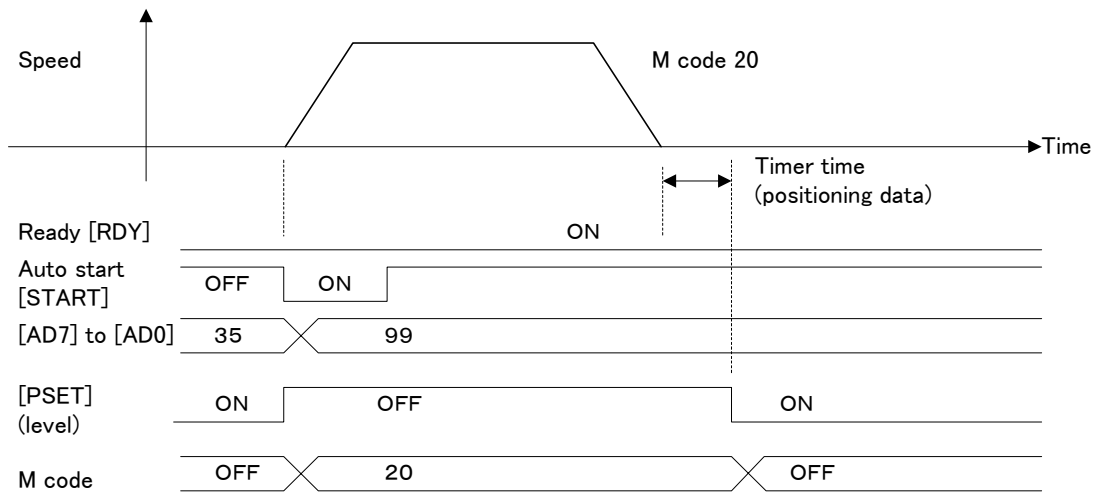

\* The elapsed time of the timer time is included in the executing time of positioning data.

Notes: (\*) MW stands for "M With." and MA stands for "M After."

Later-output [MW]  
 [MW] is outputted and retained the status, at the time of ended of positioning action.

**Later-output [MW] of M code**

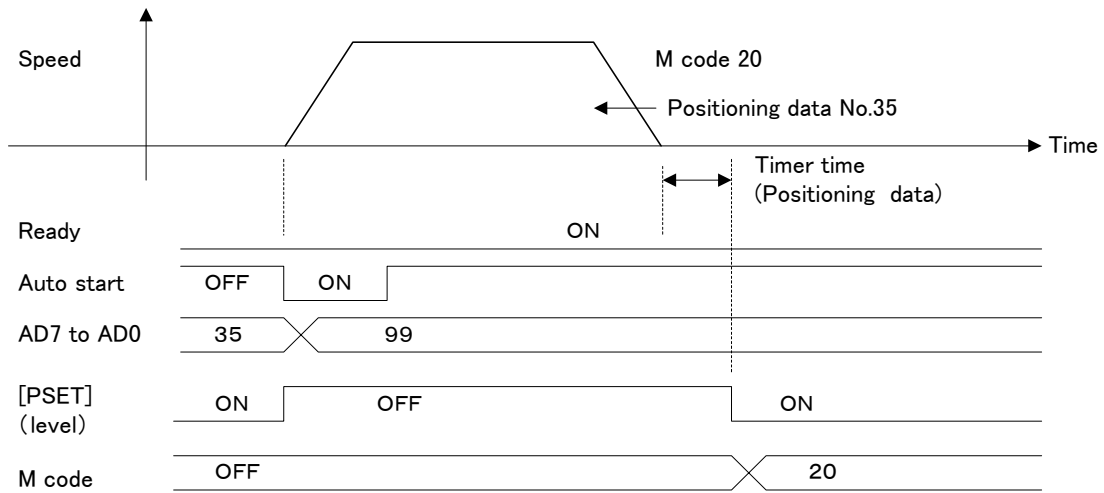

The elapsed time of the timer time is included in the executing time of positioning data.

Later-output and simultaneous output

**Later-output [MA] and simultaneous output [MW] of M code**

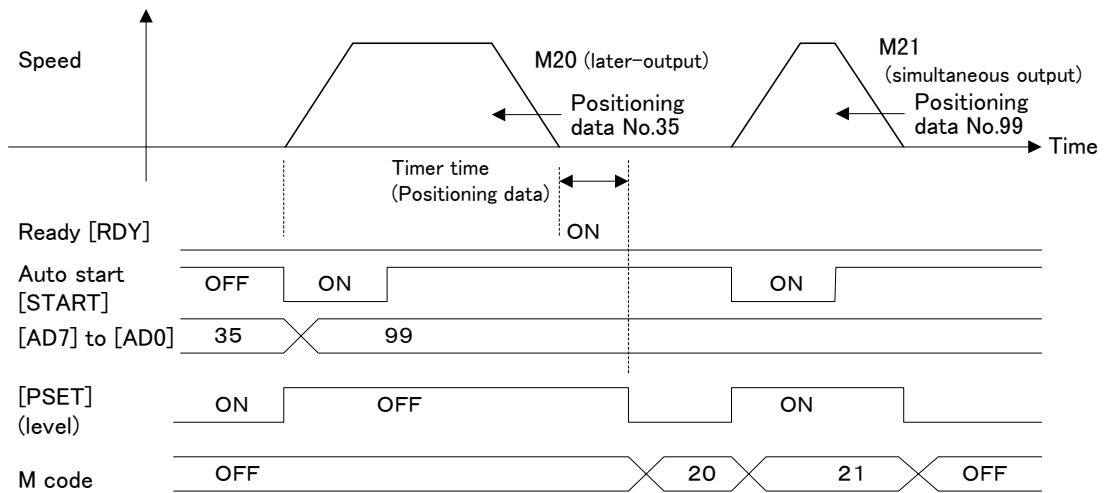

The elapsed time of the timer time is included in the executing time of positioning data.

The numbers of simultaneous outputs and later-outputs of M code are not limited.

• Data continuation [CO] (positioning data)

In case positioning data are continuous by the data continuation (CO), they are successively updated according to the positioning data.

- Positioning cancel

If positioning data under execution have been suspended by a positioning cancel signal, M code is updated when outputting a positioning end signal.

- Temporary stop

When positioning data under execution have been suspended by a temporary stop signal, M code is outputted assuming that a positioning action is extended.

- Forced stop [EMG] /external fault input

If positioning data under execution have been suspended by [EMG] signal, M code output is retained.

- M code output after turning on power

M code output is turned off.

- OUT assign: Basic type (DI/DO position)

All of M code 0 to M code 7 need not be assigned to OUT assign terminals.

They can also be assigned to terminals of discontinuous numbers.

### 5.5.6 Positioning cancel

The signal cancels a positioning action being executed to stop.

---

#### Positioning cancel (Control input signal)

---

##### Function

At the ON edge, the positioning cancel (32) signal cancels the positioning action and starts deceleration.

During the ON period, auto start [START], origin return [ORG] and interrupt positioning commands are ignored.

The signal is invalid for pulse train ratio 1, 2, or manual running [FWD/REV].

The deceleration is made in a specified decel. time.

##### Parameter setting

To allocate the positioning cancel to a control input terminal, set (32) to a system para..

If this signal is not allocated to the control input terminal, this signal is deemed "always off".

##### Related item

The forced stop [EMG] (10) signal, external fault input (34), and free-run [BX] (54), etc. that are signals for stopping take a precedence.

The motor decelerates quickly until it stops.

### 5.5.7 Temporary stop

The signal temporary stops a positioning action being executed.

---

#### Temporary stop (Control input signal)

---

##### Function

At the ON edge, the temporary stop (31) starts deceleration.

During the on period, auto start [START], origin return [ORG] or interrupt positioning command is suspended to stop its movement.

Turning it off resumes the remainder of action.

The signal is invalid for pulse train ratio 1,2, or manual running [FWD/REV].

The accel./decel. is made in a specified accel./decel. time.

The temporary stop signal is valid for a positioning action being executed.

Parameter setting

To allocate the temporary stop to a control input terminal, set (31) to a system para..

Related items

(1) Positioning cancel

If, while in temporary stop, the positioning cancel has been validated, the relevant positioning is canceled.

(2) Absolute position specified [ABS] / Relative (incremental) position specified [INC] (positioning data status)

When the temporary stop is turned off, the remainder of action is carried out, regardless of [ABS] and [INC] of positioning data. No relation with the setting value of system para. 99.

**5.5.8 Teaching**

The current position can be written in position data.

---

Teaching (Control input signal)

---

Function

At the ON edge, the teaching signal writes a current position as position data of positioning data.

The current position is an ABS (absolute position specified) value.

It can be executed any time, regardless of forced stop [EMG] or run command [RUN] off.

The rewrite end for current position can be checked by the rewrite end (13) signal assigned to OUT.

Teaching is generally executed in the following procedure.

- a) Specify any of the [AD7] to [AD0] to the address of positioning data to write in the current position.
- b) Using the manual forward command [FWD], pulse train ratio 1 or other signals, feed the mechanical equipment system to a target position.

Teaching

Control input signal	Terminal symbol	Action (while the signal is turned on)
Manual forward	FWD	Moves in increasing direction of current position
Manual reverse	REV	Moves in decreasing direction of current position
Pulse train ratio 1	CONTn	Moves at pulse train ratio 1
Pulse train ratio 2	CONTn	Moves at pulse train ratio 2

- c) At the ON edge, the teaching signal writes a current position as position data of positioning data.  
Turning off the teaching signal, turns off the rewrite end signal (13).

Time chart for teaching

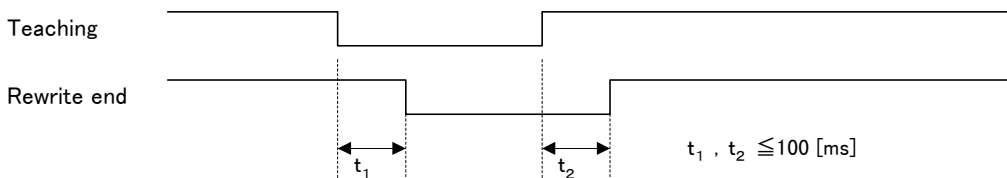

Parameter setting

To allocate the teaching to a control input terminal, set (35) to a system para..  
 If this signal is not allocated to the control input terminal, this signal is deemed "always off".

**5.5.9 Limiter detection**

This signal can stop the motor at a specified position.

---

Limiter detection (Control output signal)

---

Function

The limiter stops the motor at a specified position, when starting the motor by positioning data beyond setting by basic para. 84 or 85.  
 The limiter detection signal turns on, on condition that the positioning end signal has been outputted after stoppage.  
 Starting a positioning action with data not exceeding the specified position, turns it off.

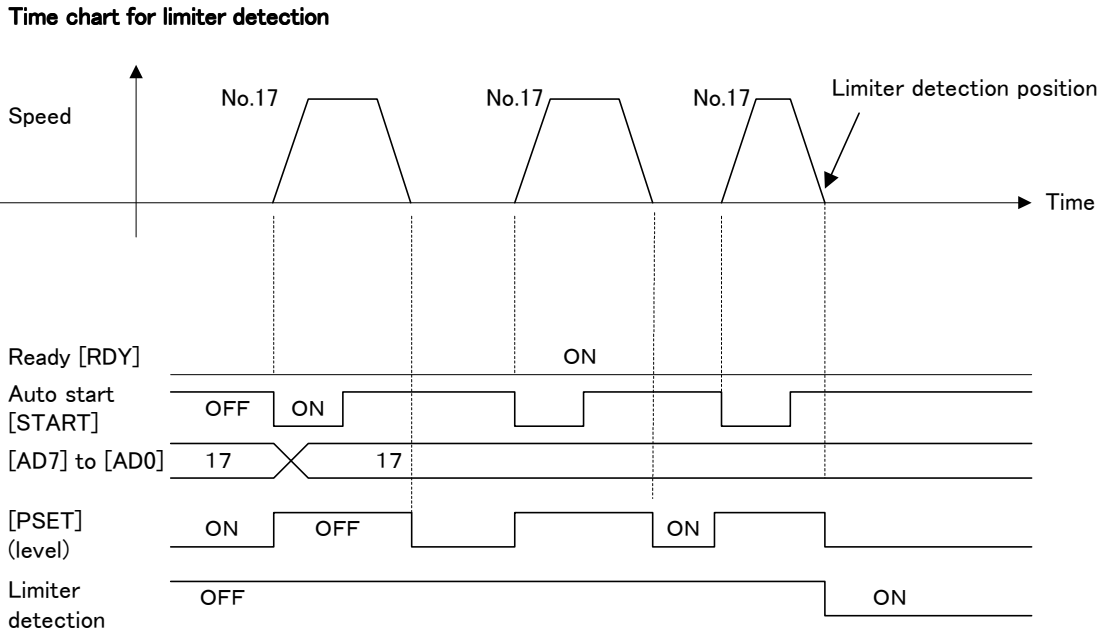

Suppose the positioning data No.17 are the sme data for which [INC] is specified.

The limiter function is convenient for moving equidistantly up to the basic para. set position.  
 The number of start times up to the set position need not be calculated.  
 The limiter detection signal is outputted only after a lapse of timer data setting for positioning data.

Parameter setting

To allocate the limiter detection to the control output terminal, set (19) to a system para.  
 Set the limiter detection position to basic para. 84 and 85.

Basic parameter 84, 85

Para.	Name	Setting range	Initial value	Change
84	+ limiter detection position	-79999999 to 0 to 79999999 (in 1 step) [x unit q'ty]	799999.99	Always
85	- limiter detection position	-79999999 to 0 to 79999999 (in 1 step) [x unit q'ty]	-799999.99	Always

## 5.6 Signal for safety

This section explains the functions and input/output signals for safety operation contained in amplifier.

Control input signal :	• Forced stop [EMG] (10) • Edit permit command (55) • + direction overtravel [+OT] (7), - direction overtravel [-OT] (8) • Torque limit [TLMT] (30) • External fault input (34)	Control output signal :	• Forced stop detection (41) • Edit permit ON (29) • OT detection (29) • +OT detection (38), -OT detection (39) • Torque limit detection (26) • Overload early warning (27)
------------------------	------------------------------------------------------------------------------------------------------------------------------------------------------------------------------------------------	-------------------------	--------------------------------------------------------------------------------------------------------------------------------------------------------------------------------------------

### 5.6.1 Forced stop [EMG]/Forced stop detection

Stops the motor forcibly using the signal to control input terminal.

---

Forced stop [EMG]/Forced stop detection (Control input / output signal)
<p>Function</p> <p>(1) Forced stop [EMG] While the [EMG] (10) signal is off, the motor is forced stopped. This input signal is always valid in any control made, and has the highest priority (all other commands are ignored.). Connect the [EMG] (10) signal directly to the control input terminal of amplifier because the safe operation and speed detecting are important. Normally, connect this terminal to a push-lock type (NC contact) pushbutton switch (Fuji's command switch is recommended).</p> <p>(2) Forced stop detection When the [EMG] (10) signal is turned off, the forced stop detection (41) signal is turned on, to be informed the current status externally. However, the forced stop detection (41) signal is turned off, while external fault input (34) is off.</p> <ul style="list-style-type: none"><li>• Basic type (D/DO position) At factory setting, the [EMG] signal is allocated to CONT13 terminal (Pin 20 of CN3).</li><li>• SX bus type (SX bus direct connection) At factory setting, the [EMG] signal is not allocated to the control input terminal of CN1. Allocate this signal to use it. When allocated to IQ area, bit ON executes the forced stop.</li><li>• T-link type (T-link direct connection) At factory setting, the [EMG] signal is not allocated to the control input terminal of CN1. Allocate this signal to use it. When allocated to WB area (at bit 5 in word +4 position), bit on executes the forced stop.</li><li>• General-purpose communication (RS485 interface) At factory setting, the [EMG] signal is allocated to CONT6 terminal (Pin 16 of CN1).</li></ul> <p>Parameter setting To allocate the [EMG] signal to the control input terminal, set (10) to the system para.. If this signal is not allocated to the control input terminal, this signal is deemed "always on". To allocate the forced stop detection signal, set (41). The [EMG] signal can be allocated to multiple terminals, and when any of those input signals is on, the motor stops forcibly.</p> <p>Related item (1) Ready [RDY] After the [EMG] (10) signal is allocated to the control terminal, when the ready [RDY] signal is turned on with both the run command [RUN] (3) and the [EMG] signals on, the motor can rotate.</p>

## (2) Forced stop status

While the [EMG] (10) signal is off and the [RUN] is on, the motor makes a stop in the speed zero status making the speed command is zero. Current position cannot be retained in the speed zero status. As the current position has been stored, the origin return action is not necessary again when the [EMG] signal is off. Turning on the [EMG] signal allows the motor to rotate.

If the [RUN] signal is off while the [EMG] is off, the motor is in free-run status.

## (3) Rotation command

While the [EMG] signal is off, all of the rotation commands are ignored.

When the alarm reset signal is on, or condition of the [EMG] signal is not needed.

### 5.6.2 Edit permit command/Edit permit ON/OFF

This function allows external signal to limit editing the parameter etc..

---

#### Edit permit command/Edit permit ON/OFF (Control input/output signal)

---

##### Function

On/off to the control input signal can limit editing or test running using keypad panel, exclusive loader or PC loader.

Only while edit permit command (55) is on, the following operation is possible.

- 1) Parameter edit mode
- 2) Test running mode

When edit permit command (55) is turned off, only monitor mode is valid.

Unexpected motor rotation or accidental lowering of vertical moving mechanical system can be prevented, occurring from careless operation of keypad panel, exclusive loader or PC loader.

##### Parameter setting

To allocate the edit permit command to the control input terminal, set (55) to the system para.. Set (29) for the edit permit ON/OFF.

##### Related items

When 1 is set at system para. 94, parameter editing with keypad panel, PC loader or exclusive loader is disabled. The system para. 94 is always rewritable.

The relation between the edit permit command and system para. 94 is as follows:

Edit permit command and system parameter 94

Edit permit command (55)	System para. 94	Edit permit ON/OFF (29)	Edit/Initialize
Not assigned	0 : Edit permitted	ON	Yes
OFF	0 : Edit permitted	OFF	No
ON	0 : Edit permitted	ON	Yes
Not assigned	1 : Edit inhibited	OFF	No
OFF	1 : Edit inhibited	OFF	No
ON	1 : Edit inhibited	OFF	No

### 5.6.3 Overtravel (OT)/Overtravel detection

Move of machine can be forcibly stopped by inputting signals from limit switch etc..

---

#### Overtravel [OT] / Overtravel detection (Control input/output signals)

---

##### Function

• + direction overtravel [+OT] (7)/ - direction overtravel [-OT] (8)  
Input signal is from (OT) preventive limit switch placed at machine moving direction end.  
Both signals are always valid except for in torque control.  
When the input signal turns off, motor rapidly decelerates to a stop in negligence of the rotation command in the detecting direction.  
Motor can rotate by pulse train input in the direction opposite to detecting direction, or by manual feed (forward command [FWD] or reverse command [REV]) (NC contact).

• +OT detection (38)/ -OT detection (39)  
While [+OT] (7) control input signal is off, the +OT detection (38) output signal is on. While [-OT] (8) control input signal is off, the -OT detection (39) output signal is on.

##### Parameter setting

To allocate the [+OT] signal to the control input terminal, set (7) to the system para. Set (8) for the [-OT] signal. If these signals are not allocated to the control input terminal, these signals are deemed "always on".  
Set (38) for the +OT detection, (39) for the -OT detection and (20) for the OT detection.

##### Related items

- (1) Detecting direction  
[+OT] signal is detected when the motor rotates toward positive direction. Positive direction is the direction set by system para.80. The motor rotates toward negative direction, and stops by detecting [+OT] signal. Afterwards, the motor cannot rotate in any direction.
- (2) +OT detection (38)/ -OT detection (39)  
The detection speed take precedence because the amplifier detects this signal at the moving direction end of mechanical equipment system. The amplifier sends the detection result to the host controller by the output signal, +OT detection or -OT detection signal. If the host controller is equipped with OT input, [OT] signal is directly sent to the host controller, in general.
- (3) OT detection (20)  
The OT detection (20) is a control output signal, and turns on when the control input [+OT] (7) or [-OT] (8) is off, or when the soft OT of system para. 75 to 77 is detected.
- (4) Function of soft OT  
When 1 is set at system para.75, the soft OT is able to operate on condition that the current position is between +soft OT and -soft OT detection position (system para. 77 and 76 setting).  
In case the current position exceeds of range, stops the motor forcibly, a control output OT detection (20) is turned on. When the pulse train input with opposite direction to the detection direction is input, or manual feed ([FWD]/[REV]) is input, and the current position returns to within the range, OT detection (20) is turned off, and it allows the mechanical equipment system to move in both directions.

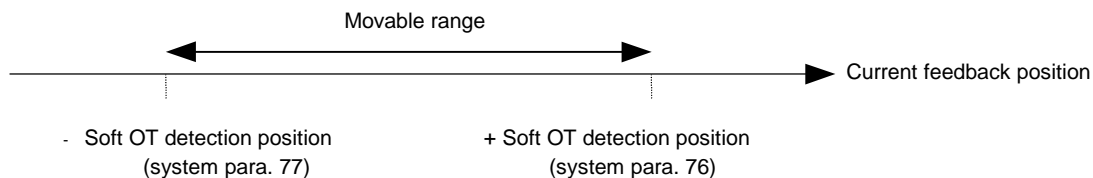

The soft OT function can be also valid after the origin return end by basic para. 67 setting.

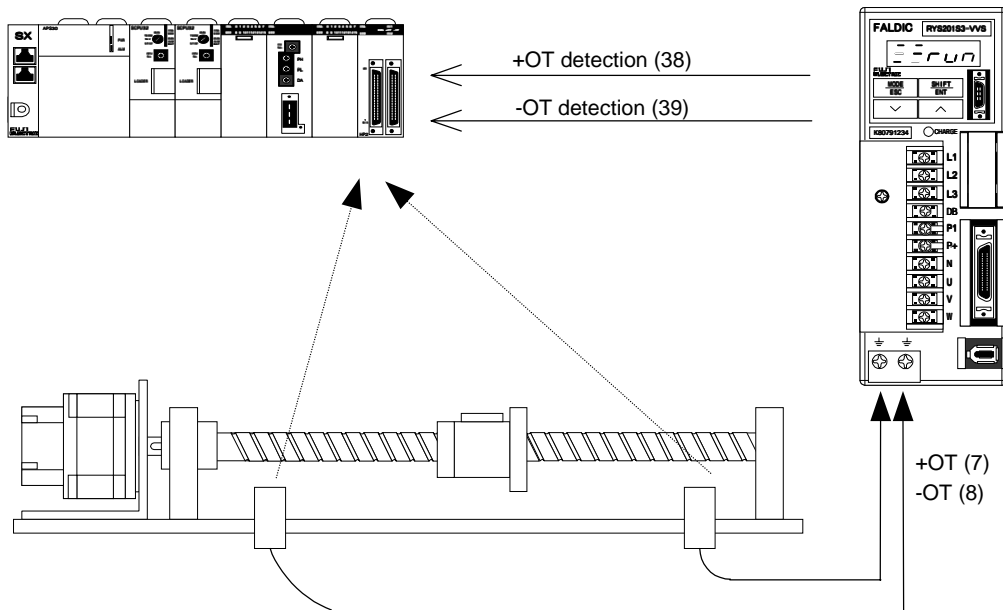

#### 5.6.4 Torque limit [TLMT]/Torque limit detection

This function limits the motor output torque.

---

##### Torque limit [TLMT]/Torque limit detection (Control input / output signal)

---

###### Function

###### (1) Torque limit

Motor output torque can be limited while [TLMT] (30) signal is on.

Torque limit value can be set by basic para. 59, from 0 to max. output torque in 1% step.

Value of the max. output torque depends on motor output rating and model type.

Motor output torque is based on the 100% rated torque.

Torque limit is always valid in any control mode.

If output torque is limited during accel. or decel., accel. or decel. time may not follow the setting value by basic para..

###### (2) Torque limit detection

This signal is turned on, while motor output torque reaches the torque limit value.

This torque limit detection (26) is always valid in any control mode.

###### Parameter setting

To allocate the [TLMT] signal to the control input terminal, set (30) to the system para.. If the [TLMT] (30) signal is not allocated to the control input terminal, the setting of basic para. 59 is always valid.

To allocate the torque limit detection signal to the control output terminal, set (26) to the system para..

### 5.6.5 External fault input

External signal forcibly stops the motor.

---

External fault input (Control input signal)

---

#### Function

While this signal is turned off, the motor is stopped forcibly.

While external fault input is applied (signal off), the operation is the same as forced stop [EMG] (10).

While external fault input is applied (signal off), forced stop detection (41) signal is turned on.

#### Parameter setting

To allocate the external fault input signal to the control input terminal, set (34) to the system para.. If this signal is not allocated to the control input terminal, this signal is deemed "always on".

#### Related item

See 5.6.1 for the forced stop (10).

### 5.6.6 Overload early warning

Motor's load factor can be checked.

---

Overload early warning (Control output signal)

---

#### Function

This signal is turned on, when the motor load factor has reached the overload early warning level set at the basic para. 58.. This signal cannot be reset by the control input signal (external signal input).

Early warning signal can be outputted before the amplifier trips due to motor overload alarm.

#### Parameter setting

To allocate the overload early warning signal to the control output terminal, set (27) to the system para..

Overload early warning output time (at 3000 [r/min])

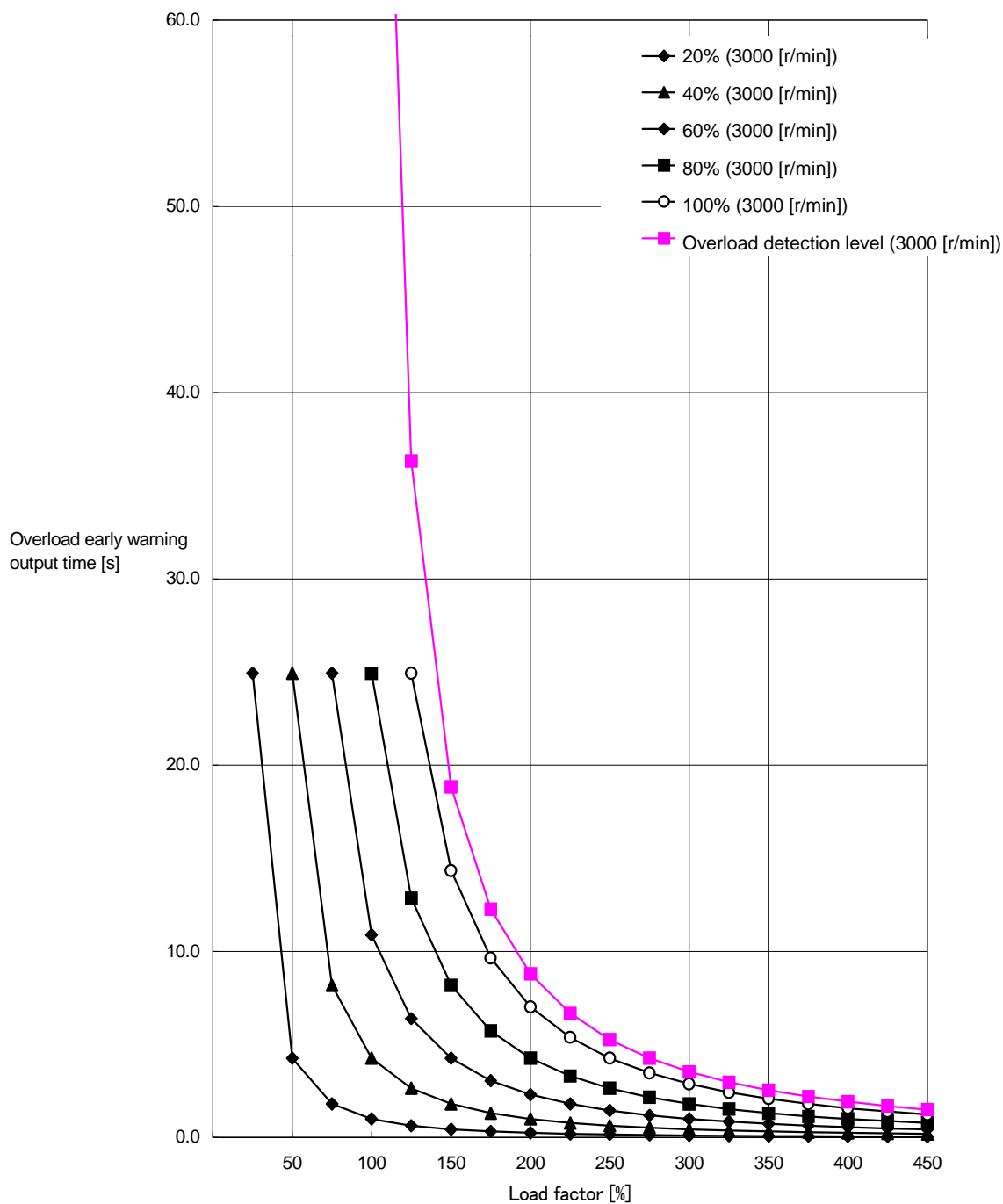

Overload early warning output time (at 5000 [r/min])

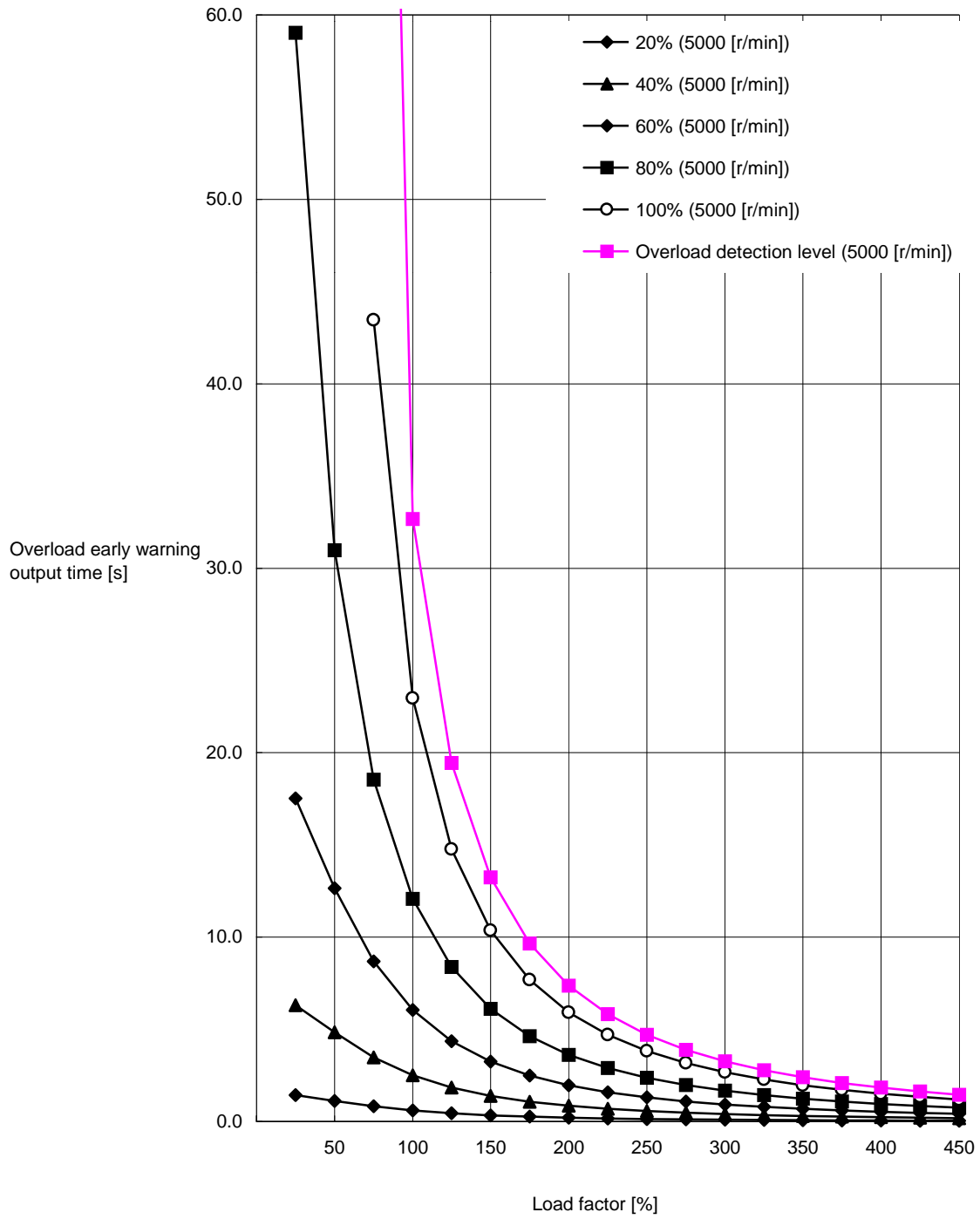

## 5.7 Incidental functions

This section explains other control functions that the amplifier supports.

Control input signal :	<ul style="list-style-type: none"><li>• Interrupt valid (48)</li><li>• Interrupt input (49)</li><li>• Override valid (43)</li><li>• Override 1 (44)</li><li>• Override 2 (45)</li><li>• Override 4 (46)</li><li>• Override 8 (47)</li><li>• Free-run [BX] (54)</li><li>• P-action (29)</li></ul>	Control output signal :	<ul style="list-style-type: none"><li>• Fixed passing point 1 (17)</li><li>• Fixed passing point 2 (18)</li><li>• Dynamic braking (15)</li><li>• Address error (31)</li><li>• Data error (30)</li><li>• CPU ready [CPURDY] (28)</li><li>• Brake timing (14)</li></ul>
------------------------	--------------------------------------------------------------------------------------------------------------------------------------------------------------------------------------------------------------------------------------------------------------------------------------------------	-------------------------	-----------------------------------------------------------------------------------------------------------------------------------------------------------------------------------------------------------------------------------------------------------------------

### 5.7.1 Interrupt positioning

An interrupt input causes movement by the determined amount and the stop.

---

Interrupt valid / Interrupt input (Control input signal)
----------------------------------------------------------

---

#### Function

Interrupt positioning can be carried out in position control status with the position control (37) signal on, and starts rotation with forward command [FWD] (revers command [REV]).

Interrupt positioning makes a start when motor has started rotation with forward (or reverse) command while interrupt valid (48) signal on. Speed in interrupt positioning follows the multistep speed selection [X1], [X2] or [X3] signals. An override can be applied to the speed.

Motor moves by the determined amount from the time at the ON edge of the interrupt input (49) signal, and then automatically stops. The move amount from interrupt input is set by basic para. 81.

The rotational speed maintains the speed of the time of ON edge of interrupt input.

While the interrupt valid (48) signal is off, interrupt input (49) is invalid.

#### Parameter setting

To allocate the interrupt valid signal to the control input terminal, set (48) to the system para.. Set (49) for the interrupt input. If these signals are not allocated to the control input terminal, these are deemed "always off".

#### Related items

(1) Interrupt movement

Move amount after interrupt input can be set at basic para. 81.

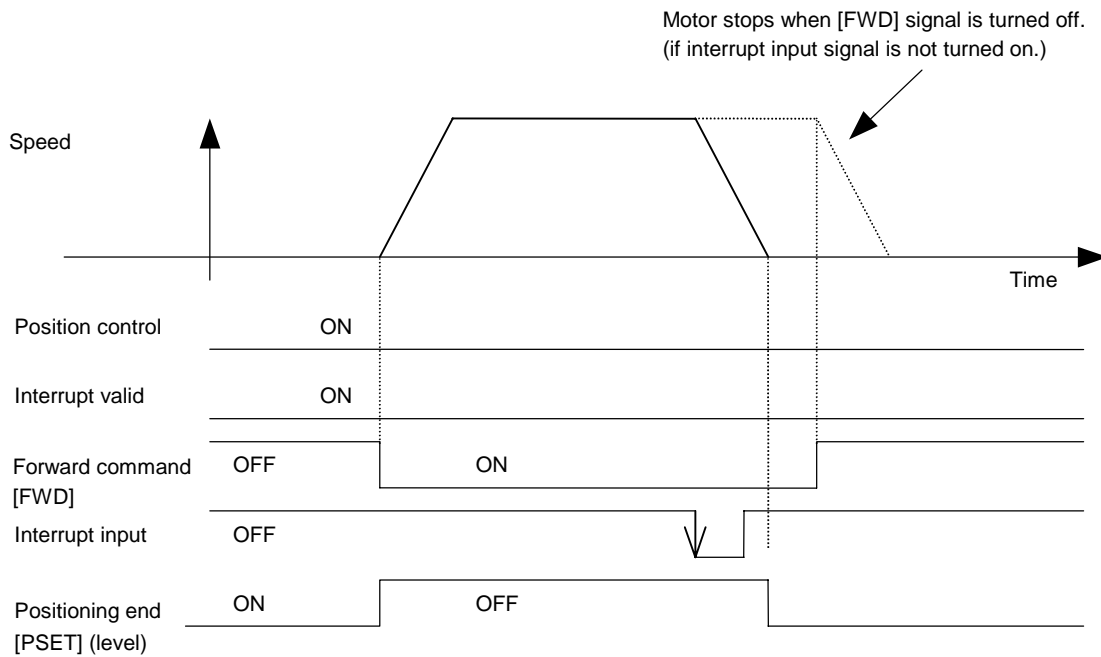

(2) Interrupt positioning accuracy

Interrupt input signal is affected by the hardware filter time 0.1 [ms] and the software sampling time interval 0.2 [ms]. Interrupt input signal is on at the same time of sampling, or approximately 0.2 [ms] later. Therefore, the signal input timing varies within  $\pm 0.1$  [ms].

When mechanical equipment system moving speed  $N=1000$  [mm/s] (60 [m/min]),  
 $1000 \times 0.0001 = 0.1$  [mm]

The response rate of the sensor which will be used for interrupt input should be considered.

Remark : Interrupt input (49) can be allocated to control input terminal of CN1.  
 In the system para., the setting value (49) can only be allocated to hardware input terminal.

**5.7.2 Fixed/Passing point**

Current position of motor can be checked.

---

Fixed / Passing point (Control output signal)

---

Function  
 Three types of output forms can be selected by the basic para. 62 setting.

1) Fixed point (setting of basic para. 62 : 0)

This output signal is on when current position is near the basic para. setting point.

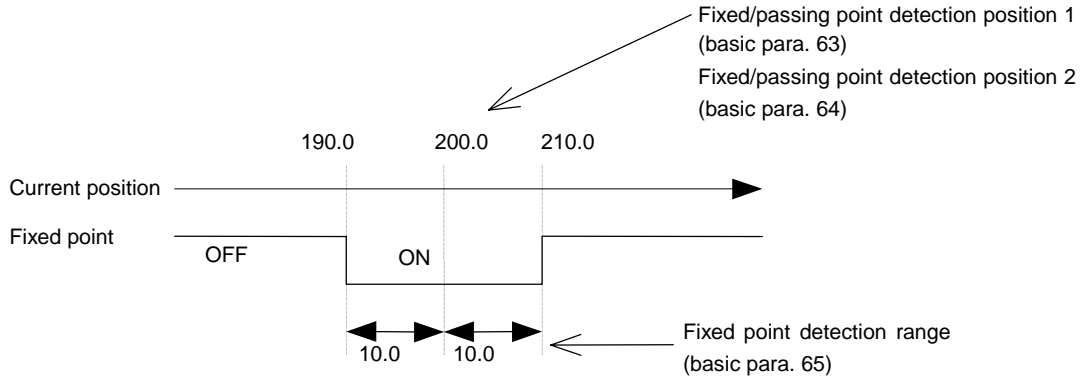

2) Passing point from off to on (setting of basic para. 62 : 1)

This signal is on when current position is beyond the basic para. setting point. The signal is off when it is less than the setting point.

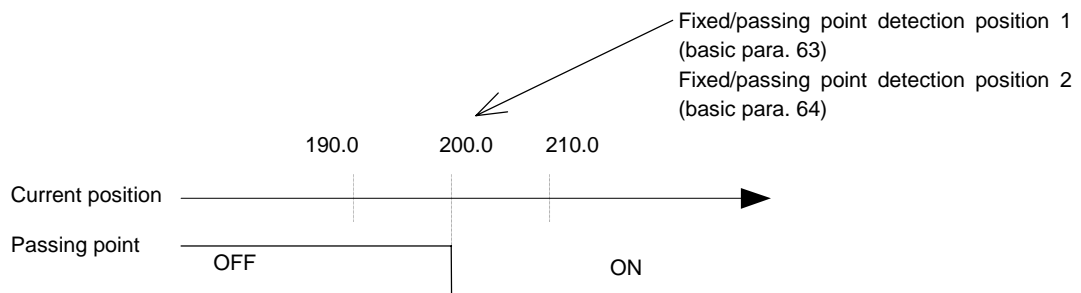

3) Passing point from on to off (setting of basic para. 62 : 2)

This signal is on when current position is less than the basic para. setting point. The signal is off when it is beyond the setting point.

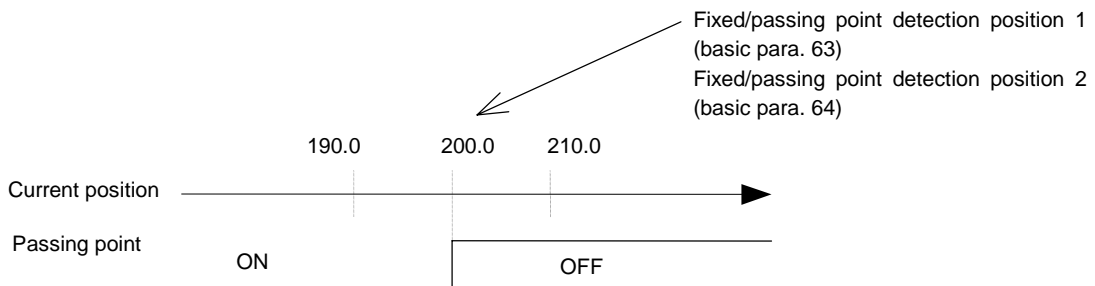

Parameter setting

To allocate the fixed/passing point 1 signal to the control output terminal, set (17) to the system para.. Set (18) for the fixed/passing point 2.

Related items

(1) Selection of output form (basic para. 62 to 65)

Output form can be set by basic para. 62 to 65.

(2) Valid or invalid of position detection function (basic para. 67)

Position detection function such as fixed/passing point 1 can be valid after origin return end.

### 5.7.3 Override

This function changes the current motor speed.

---

Override (Control input signal)

---

#### Function

While the override valid (43) signal is turned on, the motor speed is variable by a scale factor specified by the override 1/2/4/8 up to 1.5 times the current speed.

Weighting of scale factor corresponding to override 1/2/4/8 can be changed by basic para.

This function is valid for any rotational command, except for pulse train input (pulse train ratio 1 or 2).

#### Parameter setting

To allocate the override valid signal to the control input terminal, set (43) to the system para.. If this signal is not allocated to the control input terminal, this signal is deemed "always off".

#### System parameter setting

Signal name	Setting value
Override valid	43
Override 1	44
Override 2	45
Override 4	46
Override 8	47

#### Related items

##### (1) Override scale factor

The scale factors, while the override valid signal is on, are as follows.

If the override valid goes off, the 100% moving speed is obtained.

The signal not allocated to the control input terminal is deemed "always off".

#### Moving speed [%] by override (\*)

Override 8	Override 4	Override 2	Override 1	Moving speed [%]
OFF	OFF	OFF	OFF	0
OFF	OFF	OFF	ON	10
OFF	OFF	ON	OFF	20
OFF	OFF	ON	ON	30
OFF	ON	OFF	OFF	40
OFF	ON	OFF	ON	50
OFF	ON	ON	OFF	60
OFF	ON	ON	ON	70
ON	OFF	OFF	OFF	80
ON	OFF	OFF	ON	90
ON	OFF	ON	OFF	100
ON	OFF	ON	ON	110
ON	ON	OFF	OFF	120
ON	ON	OFF	ON	130
ON	ON	ON	OFF	140
ON	ON	ON	ON	150

(\*) Where override weighting is at initial value.

## (2) Override weighting

Override weighting can be changed by using basic para. 17 to 20.

### Basic parameter 17 to 20

Para.	Name	Setting range	Initial value	Change
17	Override 1	0 to 150% (in 1 step)	10	Always
18	Override 2	0 to 150% (in 1 step)	20	Always
19	Override 4	0 to 150% (in 1 step)	40	Always
20	Override 8	0 to 150% (in 1 step)	80	Always

When the override 8, 4, 2 and 1 are all on, adding all initial values gives 150 (= 80 + 40 + 20 + 10). If the initial value has been changed and resultant sum exceeded 150, the preceding value is retained.

## (3) Max. speed

Max. speed of the motor output shaft can be set by basic para.16 setting. However, this setting is invalid while pulse train input exists.

### 5.7.4 Free-run [BX]

This function puts the motor into free-run status forcibly.

---

#### Free-run [BX] (Control input signal)

---

##### Function

While [BX] signal is on, the amplifier output is off, and the motor is in free-run status. Motor decelerates (or accelerates) with the loaded torque.

The [BX] signal is always valid.



#### **CAUTION**

**For safety purpose, do not use this signal to the vertically moving mechanical equipment.**

If this signal is turned on, when using a manual pulse generator with pulse train input (pulse train ratio 1), the handle angle may differ from the motor rotational quantity.

##### Parameter setting

To allocate the [BX] signal to the control input terminal, set (54) to the system para..

##### Related item

The [BX] signal takes the precedence over any other signals in all the control modes.

### 5.7.5 P-action

The speed control is subordinate to proportional band control.

---

#### P-action (Control input signal)

---

##### Function

This signal is turned on while locking the motor shaft mechanically, with the run command [RUN] on. See 5.7.10 Brake timing.

Speed control and position control become unstable if P-action signal is on during motor rotating. Never put this signal on during motor rotating.

##### Parameter setting

To allocate the P-action signal to the control input terminal, set (29) to the system para.. If this signal is not allocated to the control input terminal, this signal is deemed "always off".

### 5.7.6 Dynamic braking

This signal is turned on when the amplifier detects major fault.

---

#### Dynamic braking (Control output signal)

---

##### Function

This signal is turned on when a major fault has occurred that the amplifier cannot drive the motor, and is retained until alarm reset signal is input.

Dynamic braking is a braking type to generate power, by short-circuiting the three-phase winding of a synchronous motor. Once the motor is stopped, braking force is not retained.

The output terminal of dynamic braking is +30 [V] DC, 50 [mA]. This cannot directly close a magnetic contactor. Use a general-purpose relay or Fuji's SSC (solid state contactor).

##### Parameter setting

To allocate the dynamic braking signal to the control output terminal, set (15) to the system para..

##### Related items

- Major fault

Fault that cannot drive motor

Indication	Detection contents
AL SE	System error
AL OC	Overcurrent
AL OS	Overspeed
AL LU	Undervoltage
AL HU	Overvoltage
AL ET	Encoder trouble
AL CT	Control power trouble
AL DE	Memory error
AL Fb	Fuse blown
AL CE	Motor combination error
AL RH2	Resistor overheat 2
AL EC	Encoder communication error
AL CE	Control signal error
AL OL	Motor overload

- Minor fault

Protection against overheat etc.

Indication	Detection contents
AL RH	Braking resistor overheat
AL OF	Deviation excessive
AL AH	Amplifier overheat
AL EH	Encoder overheat
AL AL	ABS (absolute) data lost
AL AF	Absolute data overflow
AL EE	Bus communication error

### 5.7.7 Address error

Address error of address (positioning number) and para. number at para. editing can be checked.

---

#### Address error (Control output signal)

---

##### Function

This signal turns on, if the following address error is detected at auto start [START] and para. rewrite.

- 1) Data other than BCD code is input.
- 2) Data other than setting range is input.
- 3) Data with negative sign is specified.

This signal turns off, when [START] signal inputs at a correct address, or data rewrite is executed.

Even if an address error is on, the motor shaft is not stop.

- Basic type (DI/DO position)

The address error signal is on, when AD7 to AD0 setting error specifying address in CONT 14 to CONT21 of connector 3 (CN3) is detected. At factory setting, this signal is allocated to OUT4 (No.7 pin of connector 1(CN1)).

- SX bus type (SX bus direct connection)

The address error signal is on, when an error is detected at word 14 position (lower order 8 bit) of IQ area. At factory setting, this signal is allocated to OUT8 (word 7, bit 10).

- T-link type (T-link direct connection)

The address error signal is on, when an error is detected at word +5 (lower order 8 bit) (address number) area of WB area. At factory setting, this signal is allocated to OUT9 (word +0, bit 4).

- General-purpose communication (RS485 interface)

The address error signal is set at 6 bit position of ST1 in the response message.

When this signal is allocated to OUT5 and above of system para., the signal can affect to ST2.

This signal can be allocated to control output terminal of CN1.

#### Parameter setting

To allocate the address error signal to the control output terminal, set (31) to the system para..

### 5.7.8 Data error

A data error at immediate positioning and at para. editing can be checked.

---

#### Data error (Control output signal)

---

#### Function

This signal turns on, if the following data error is detected at auto start [START] and para. rewrite.

- 1) Data other than specified code (BCD or binary) is input.
- 2) Data other than setting range is input.
- 3) Data with negative sign is specified.

This signal turns off, when [START] signal inputs at a correct data or data rewrite is executed.

Even if a data error is on, the motor shaft is not stop.

It turns on or off according to the output timing of the rewrite end (13) signal.

- Basic type (DI/DO position)

The data error signal is on, when AD7 to AD0 setting error in the input data at immediate positioning is detected. At factory setting, this signal is allocated to OUT3 (No. 26 pin of connector 1 (CN1)).

- SX bus type (SX bus direct connection)

The data error signal is on, when an error is detected at word 8 and 9 position of IQ area.

At factory setting, this signal is allocated to OUT7 (word 7, bit 11).

- T-link type (T-link direct connection)

The data error signal is on, when an error is detected at word +6 and +7 (rewrite data) area of WB area.

At factory setting, this signal is allocated to OUT14 (word +0, bit 9).

- General-purpose communication (RS485 interface)

The data error signal is set at 6 bit position of ST1 in the response message.

When this signal is allocated to OUT5 to OUT21 of system para., the signal can store to bit of ST2.

This signal can be allocated to control output terminal of CN1.

#### Parameter setting

To allocate the data error to the control output terminal, set (30) to the system para..

### 5.7.9 CPU ready [CPURDY]

Normal operation of amplifier and motor can be checked.

---

#### CPU ready [CPURDY] (Control output signal)

---

##### Function

This signal is turned on under the following conditions, after power is turned on.

- CPU in the amplifier is operating normally.

[CPURDY] signal output has no relation with control input signal on/off status.

When the [CPURDY] signal is off, the contents of the control output may be incorrect.

##### Parameter setting

To allocate the [CPURDY] signal to the control output terminal, set (28) to the system para..

### 5.7.10 Brake timing

This signal is automatically turn on or off for the brake operation.

---

#### Brake timing (Control output signal)

---

##### Function

This signal automatically excites or releases the motor brake, in accordance with the rotational command to the amplifier.

The control condition when the motor is stopped can be set by system para. 81.

##### Parameter setting

To allocate the brake timing output to the control output terminal, set (14) to the system para.. If this signal is not allocated to the control output terminal, this signal is deemed "always off".

##### Related items

#### (1) Brake timing

The step to set the brake timing at the control output terminal is as follows:

##### 1) Setting of control output terminal

Assign the value (14) corresponding to the brake timing to the system para. 31 and above. If value (14) is set at the system para. 31, OUT1 terminal is the output terminal of brake timing.

##### 2) Setting at stoppage

Set "2" or "3" at the system para. 81 to select the status while motor is stopping. When "3" is set at para. 81, the motor comes to free-run status when operating the brake and electromagnetic noise of motor is eliminated.

##### 3) Brake operation time/release time

Assign the operating time and release time of external brake to system para. 82 and 83.

To each time period, add the scan time of PLC, the response time of external relay, magnetic contactor and the brake.

(2) Pulse train/manual feed (Forward command [FWD]/Reverse command [REV])

The brake timing output is held off, from when the power is turned on until rotational command is given.

When the following control input signals are given, the brake timing output is turned on.

1) [FWD], [REV]

2) Pulse train ratio 1, pulse train ratio 2

When starting a movement :

1) [FWD]/[REV]

The brake timing is turned on simultaneously, when control input ([FWD] or [REV]) signal is on.

After the brake release time (system para. 83) has elapsed, a rotation starts assuming that brake has actually been released. If [FWD] or [REV] has been turned off during the brake release time, the motor will not start rotation.

2) Pulse train ratio 1/Pulse train ratio 2

The brake timing is turned on simultaneously, when the control input signal is on.

After the brake release time (system para. 83) has elapsed, pulse train input becomes valid assuming that it has been actually released. If the control input signal has been turned off during the brake release time, the pulse train input is invalid.

When terminating the movement :

1) [FWD]/[REV]

When [FWD] or [REV] has turned off, the motor starts deceleration. After the speed zero [NZERO] signal on is confirmed, brake timing turns off, and when brake operation time (system para. 82) has elapsed, the amplifier turns P-action signal on. The same procedure as when starting a movement above, is performed if a rotational command is turned on during the brake operation time.

2) Pulse train ratio 1 / Pulse train ratio 2

After [FWD] or [REV] signal is off, pulse train input becomes invalid with deviation zero signal on.

After the deviation zero signal on is confirmed, brake timing turns off, and when brake operation time (system para. 82) has elapsed, the amplifier turns P-action signal on.

The same procedure as when starting a movement above, is performed if a rotational command is turned on during brake operation time.

System parameter 81 to 83

Para.	Name	Setting range	Initial value	Change
81	Operation at stoppage	0: Speed zero, 1: Servo lock, 2: Brake (P-action), 3: Brake (free-run)	0	Power
82	Brake operation time	0.01 to 9.99 [s] (in 0.01 step)	0.50	Always
83	Brake release time	0.01 to 9.99 [s] (in 0.01 step)	0.20	Always

Brake timing : Validated signal at ON level

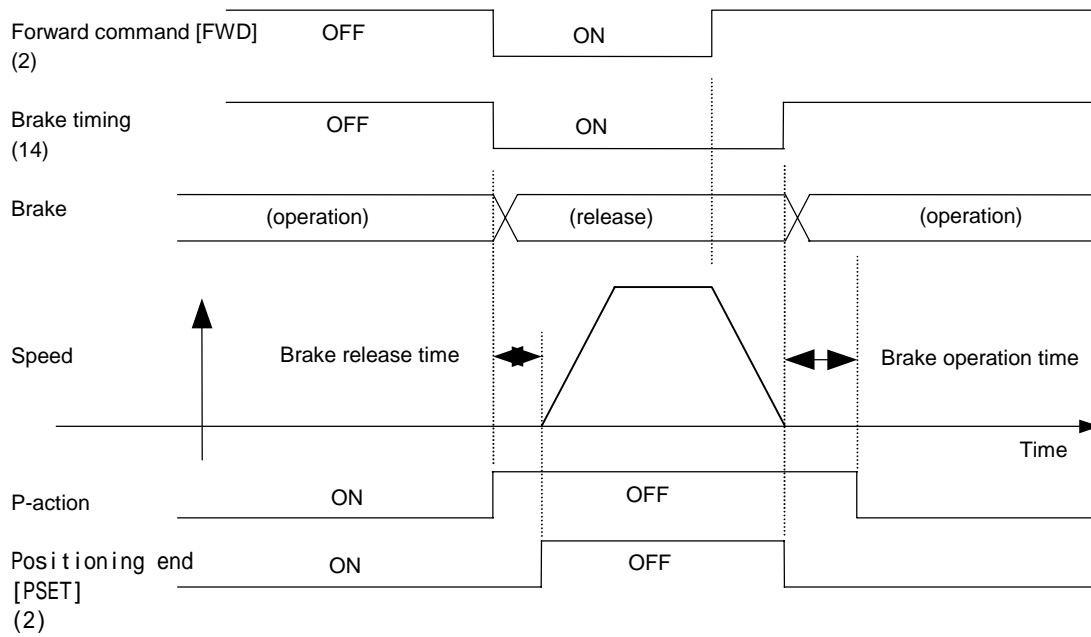

• Brake release time

Time period from when the amplifier output is on, until when the external brake release is ended. Just after the brake release time, the brake is operating and the motor is in servo lock status.

The ON level of the rotational command makes the P-action signal off. The P-action signal is on inside the amplifier.

• Brake operation time

Time period from the amplifier output is off, to starts the braking operation.

After positioning is ended, brake timing output is turned off. Just after the brake operation time, the motor is stopping by servo lock only.

During brake operation time, the servo lock and the brake is in operation. After the brake operation time has elapsed, P-action is on and the motor stops with brake.

(3) Origin return [ORG]/Auto start [START]

The brake timing output is held off, from the power is turned on until the rotational command is given. When the following control input (ON edge) signals are given, the brake timing output is turned on.

When starting a movement :

Brake timing turns on at the ON edge of control input signal.

After the brake release time (system para. 83) has elapsed, a rotation starts assuming that the brake has actually been released.

When terminating the movement :

After the amplifier has checked the deviation zero (positioning end), turned off the brake timing, and the brake operation time (system para. 82) has elapsed, the amplifier turns on P-action signal.

The same procedure as when starting a movement above, is performed if a movement restarts at the ON edge of control input signal during the brake operation time.

Brake timing : Validated signal at the ON edge

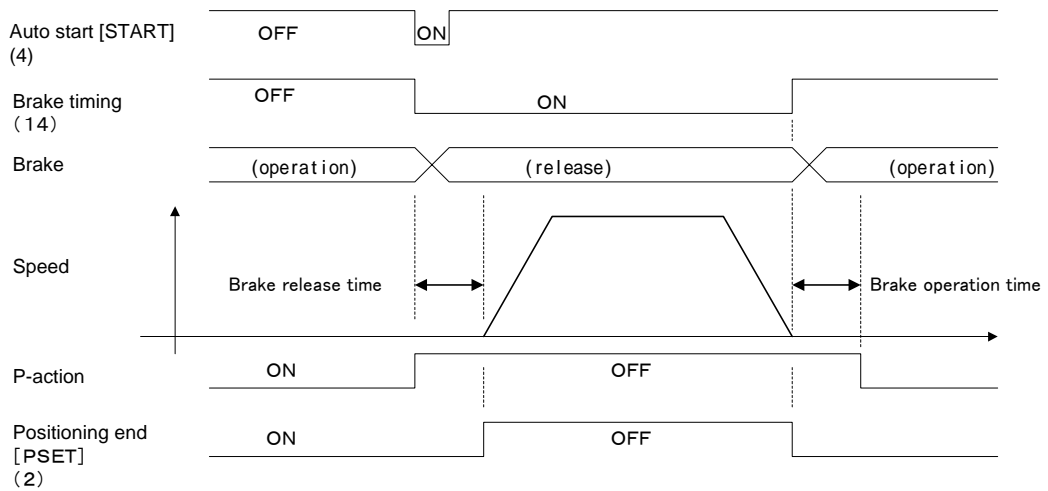

- If an external brake (free-run) is used, the motor comes to free-run status at the timing of P-action as shown on the above figure.
- During brake operation time, mechanical brake and servo lock (before P-action) are executed simultaneously. For vertically moving mechanical equipment, there are no time period of motor free-run during stopping.

External connection diagram (example), 0.4 and 0.75 [kW]  
 (with brake timing output signal)

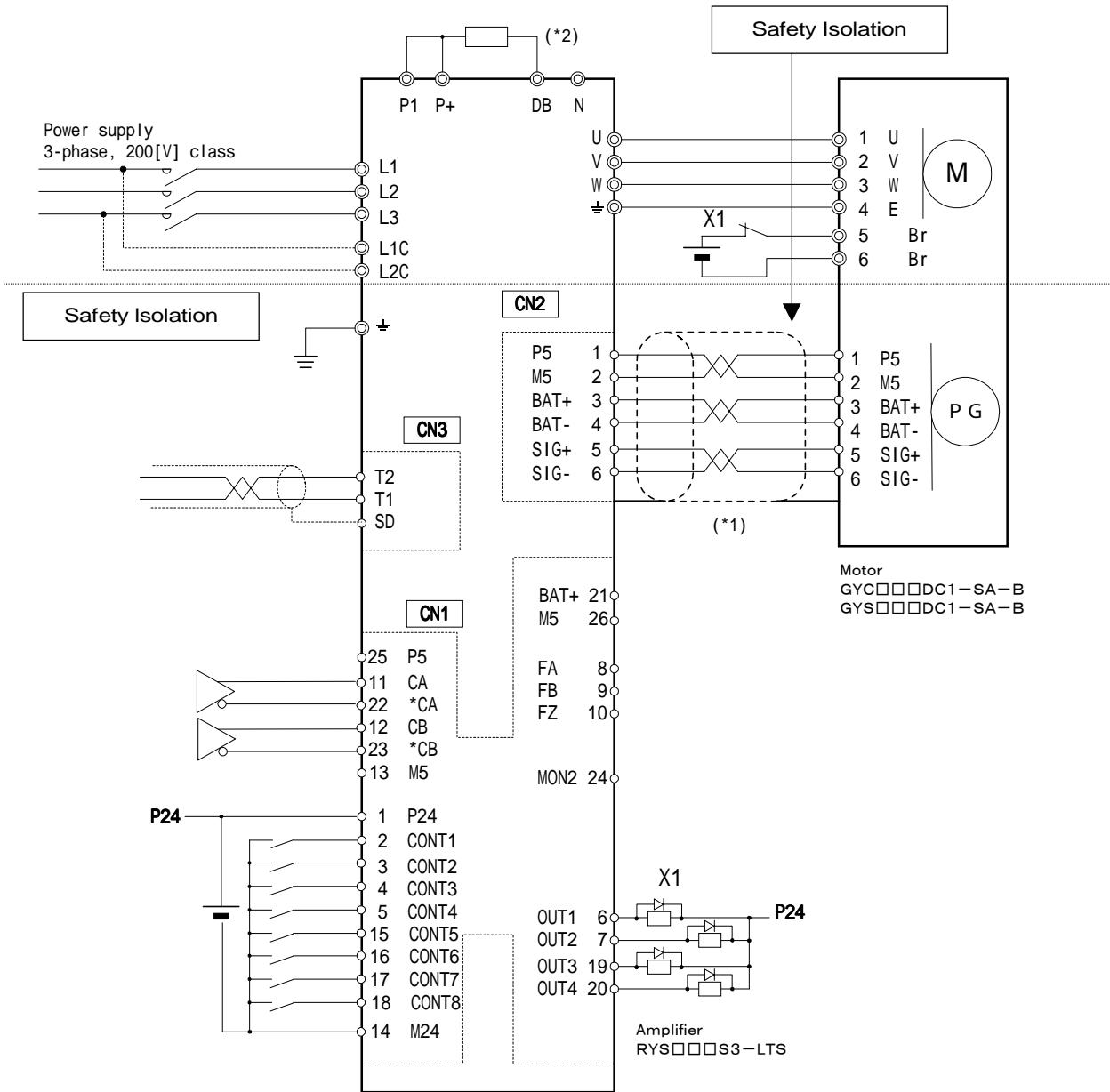

(\*1) Shielded sheath on the shielded cables must be connected with the shell body and the shell cover.

(\*2) A braking resistor is provided (built-in) with amplifier.

When the servo lock is released at the alarm detection, run command [RUN] off and forced stop [EMG] off, the brake timing output is off.

- Alarm detection

At alarm detection, the brake timing output goes off immediately to operation the braking.

- [RUN] (1)

At [RUN] off, the motor decelerates quickly and turns off by the [NZERO] (24) signal on.

- +direction overtravel detection (7)/-direction overtravel detection (8)/[EMG] (40)

At signal off, the motor decelerates quickly and turns off by the speed zero (24) signal on.

- Temporary stop (31)

At the ON edge of temporary stop signal, the motor starts deceleration and turns off by the deviation zero (23) signal on.

When the temporary stop is off, the remained action is executed.

The brake timing at signal off is same as "when starting a movement".

- Positioning cancel (32)

At the ON edge of positioning cancel signal, deceleration starts. The brake timing is same as "when terminating the movement".

- Deviation clear (50)

The deviation clear is valid during the speed zero (24) signal on. The inputting of deviation clear does not affect the brake timing.

- Free-run [BX] (54)

During [BX] signal on, the motor is in free-run status, and turns off at speed zero (24) signal on.

Remark : Using the current position output (56) forcibly changes the functions of OUT1 to OUT3 terminals.

When this terminal is used as brake timing purpose, cut off the exciting circuit of the brake externally.

## 5.8 IQ area

This section explains the IQ area of RYS S3-LSS type.

RYS S3-LSS type amplifier reserves 16 word in the IQ area.

### (1) Station number

The station number selects the individual module with amplifier in the system definition of D300win.

The arbitrary number can be specified as the station number.

Set (0) as the station number of the amplifier. Set a different station number if a fail-soft operation for SX bus type is valid.

### (2) Read/rewrite data

The lower order 8 words of IQ area are the read area, and the higher order 8 words are the rewrite area.

The data whether to read or rewrite can be selected by on/off of SEL0, SEL1, SEL2 at bit 8 to 10 in word +14.

When the CSEL0, CSEL1, and CSEL2 of word +5 are simultaneously on or off, the change of the area can be checked.

### (3) CONT/OUT

The bit information at 7 word and bit command at 15 word position are valid in all the read/rewrite data status.

モジュール挿入

SXバス局番(N): 8 回線番号(B):

名称(M): 直線位置決め

概略仕様(C): 直線位置決め

形式: RYS-LS

消費電流(mA):

モジュール属性(I):

- ハードボード集合形モジュール
- 個別形モジュール
- その他

モジュール種別(K):

- POD
- サーボ
- その他
- 
- 
- 
- 

挿入位置(I):

- 挿入
- 追加

未実装(Q)

OK  
キャンセル  
パラメータ(P)...  
ヘルプ(H)

• IQ area

Address	15	14	13	12	11	10	9	8	7	6	5	4	3	2	1	0
0	Current position, current deviation, basic para., system para., current position data/LS-Z phase pulse (Low order word PC Amplifier)															
1	Current position, current deviation, basic para., system para., current position data/LS-Z phase pulse (High order word PC Amplifier)															
2	Current speed, current speed data (Low order word PC ← Amplifier)															
3	Current speed, current speed data (High order word PC ← Amplifier)															
4	Current torque/current timer data (PC ← Amplifier)															
5	-					Alarm code/current status			Current M code							
6	-					CSEL 2	CSEL 1	CSEL 0	Current para. No./current positioning data							
7	OUT 3	OUT 4	OUT 5	OUT 6	OUT 7	OUT 8	OUT 9	OUT 10	OUT 11	OUT 12	OUT 13	OUT 14	OUT 15	OUT 16	Rewrite end	Read end
8	Basic para., system para., position data (Low order word PC → Amplifier)															
9	Basic para., system para., position data (High order word PC → Amplifier)															
10	Speed command, speed data setting (Low order word PC → Amplifier)															
11	Speed command, speed data setting (High order word PC → Amplifier)															
12	Timer data setting (PC → Amplifier)															
13						Status setting			M code setting							
14	-					SEL2	SEL1	SEL0	Para. No. setting/positioning data setting							
15	CONT 6	CONT 7	CONT 8	CONT 9	CONT 10	CONT 11	CONT 12	CONT 13	CONT 14	CONT 15	CONT 16	CONT 17	CONT 18	CONT 19	Rewrite command	Read command

Read/rewrite data (select)

SEL2	SEL1	SEL0	IQ area (Upper line: 0 to 7W, Lower line: 8 to 15W)
OFF	OFF	OFF	Current command position, current speed, current torque, current M code Positioning data setting, speed command/speed data setting
OFF	OFF	ON	Current feedback position, current speed, current torque, current M code Positioning data setting, speed command/speed data setting
OFF	ON	OFF	Current deviation, current speed, current torque, current M code Positioning data setting, speed command/speed data setting
OFF	ON	ON	- -
ON	OFF	OFF	Current basic para. Basic para. setting
ON	OFF	ON	Current system para. System para. setting
ON	ON	OFF	Current positioning data Positioning data setting
ON	ON	ON	Current pulse value between LS-Z phase -

#### (4) Read command / Rewrite command

To read the positioning data, basic para., and system para., turn on the read command at bit 0 in word 15 position. The read end at bit 0 in word 7 turns on, when reading is ended.

To perform write, turn on the rewrite command at bit 1 in word +15. The rewrite end at bit 1 in word 7 turns on.

Data such as current command position that always changes, can be read out continuously at the ON edge of read command.

#### (5) Immediate positioning

Position data can be written into position of IQ area.

##### • Preparation

Run command [RUN] (at bit 15 in word 15) turns on.

Para. editing and positioning data editing can not be selected at SEL2, SEL1, SEL0.

• Immediate start : See to of the table below.

: Set the position data to 8, 9 word.

: Select the rotational speed at VEL0, VEL1.

: Select the absolute position specified [ABS] or the relative position specified [INC] at position data.

: Set the "FF" to para./positioning data.

: The motor starts rotation at the ON edge of [START] signal.

: Rotational speed can be specified, with setting of VEL0 and VEL1 ((12) and (13) of system para.) is zero, and power turns on again.

#### (6) Auto start : See and of the table below.

: Set the positioning data number in the para./positioning data area.

: The motor starts rotation at the ON edge of [START] signal.

#### (7) Manual feed

The rotational speed at forward command [FWD] and reverse command [REV] is specified by the speed command (see of the table below) while multistep speed selection [X1] is off.

The [X1] is at bit 9 in 15 word (at factory setting) position.

• IQ area (at factory setting)

Address	15	14	13	12	11	10	9	8	7	6	5	4	3	2	1	0
0	Current position, current deviation, basic para., system para., current position data/LS-Z phase pulse (Low order word PC Amplifier)															
1	Current position, current deviation, basic para., system para., current position data/LS-Z phase pulse (High order word PC Amplifier)															
2	Current speed, current speed data (Low order word PC ← Amplifier)															
3	Current speed, current speed data (High order word PC ← Amplifier)															
4	Current torque/current timer data (PC ← Amplifier)															
5	-						Alarm code/current status			current M code						
6	-						CSEL 2	CSEL 1	CSEL 0	Current para. No./current positioning data						
7	RDY	PSET	CPU ready	ALM	Data error	Address error	-	-	-	-	-	-	-	-	Rewrite end	Read end
8	Basic para., system para., position data (Low order word PC → Amplifier)															
9	Basic para., system para., position data (High order word PC → Amplifier)															
10	Speed command, speed data setting (Low order word PC → Amplifier)															
11	Speed command, speed data setting (High order word PC → Amplifier)															
12	Timer data setting (PC → Amplifier)															
13	-						Status setting			M code setting						
14	-						SEL2	SEL1	SEL0	Para. No. setting/positioning data setting						
15	RUN	FWD	REV	RST	START	ORG	X1	VEL0	VEL1	ABS INC	-	-	-	-	Rewrite command	Read command

For the immediate start, this command is not needed.

Current command position/current feedback position/current deviation  
The current command position etc. can be selected at on/off of SEL0, SEL1, SEL2.  
The positions are read out continuously at the ON edge of read command.

Read/rewrite data (select)

SEL2	SEL1	SEL0	IQ area (Upper line: 0 to 7W, Lower line: 8 to 15W)
OFF	OFF	OFF	Current command position, current speed, current torque, current M code Position data setting, speed command/speed data setting
OFF	OFF	ON	Current feedback position, current speed, current torque, current M code Position data setting, speed command/speed data setting
OFF	ON	OFF	Current deviation, current speed, current torque, current M code Position data setting, speed command/speed data setting

Address	15	14	13	12	11	10	9	8	7	6	5	4	3	2	1	0
0	Current command position, current feedback position, current deviation (Low order word PC ← Amplifier)															
1	Current command position, current feedback position, current deviation (High order word PC ← Amplifier)															
2	Current speed (Low order word PC ← Amplifier)															
3	Current speed (High order word PC ← Amplifier)															
4	Current torque (PC ← Amplifier)															
5	-			ALM4	ALM3	ALM2	ALM1	ALM0	Current M code							
6	-					CSEL 2	CSEL 1	CSEL 0	-							
7	RDY	PSET	CPU ready	ALM	Data error	Address error	-	-	-	-	-	-	-	-	Rewrite end	Read end
8	Position data (Low order word PC → Amplifier)															
9	Position data (High order word PC → Amplifier)															
10	Speed command, speed data setting (Low order word PC → Amplifier)															
11	Speed command, speed data setting (High order word PC → Amplifier)															
12	-															
13	-	-	-	-	-	-	-	-	-							
14	-					SEL2	SEL1	SEL0	Positioning data setting							
15	RUN	FWD	REV	RST	START	ORG	X1	VEL0	VEL1	ABS INC	-	-	-	-	Rewrite command	Read command

Current command position/current feedback position/current deviation

Word position	Setting range
Address 0	Current command position, current feedback position or current deviation (2 word) is stored. Current position is corresponds to unit quantity, deviation amount is in 1 pulse unit.
Address 1	
Address 2	Current rotational speed is stored in 2 word. The min. value 1 is corresponds to 1 [r/min].
Address 3	
Address 4	Current output torque is stored in 1 word. The min. value 1 is corresponds to 1% of rated (100%) torque.
Address 5	
Address 6	Alarm code and current M code are stored.
Address 7	
Address 8	The status of SEL2, SEL1 and SEL0 are stored.. (information on each bit is always valid.)
Address 9	
Address 10	Position data of immediate positioning can be set. The min. value 1 is corresponds to unit quantity.
Address 11	
Address 12	Rotational speed can be specified at [FWD] / [REV] (X1 to X3 are all off). The speed data at immediate positioning can be set (when VEL1, VEL0 being not specified). The min. value 1 is corresponds to 0.01 [r/min].
Address 13	
Address 14	(disabled)
Address 15	
Address 15	Data read out using SEL2 to SEL0 can be specified. No. of para./positioning data setting can be specified. (command on each bit is always valid.)

Basic parameter/system parameter

The read or rewrite of parameter can be selected at on/off of SEL0, SEL1, SEL2.

Read/rewrite data (select)

SEL2	SEL1	SEL0	IQ area (Upper line: 0 to 7W, Lower line: 8 to 15W)
ON	OFF	OFF	Current basic para. Basic para. setting
ON	OFF	ON	Current system para. System para. setting

Do not specify the following:

SEL2	SEL1	SEL0	IQ area (Upper line: 0 to 7W, Lower line: 8 to 15W)
OFF	ON	ON	- -

Address	15	14	13	12	11	10	9	8	7	6	5	4	3	2	1	0	
0	Current basic para., system para. (Low order word PC ← Amplifier)																
1	Current basic para., system para. (High order word PC ← Amplifier)																
2	-																
3	-																
4	-																
5	-	-	-	-	-	-	-	-	-	-	-	-	-	-	-	-	
6	-					CSEL 2	CSEL 1	CSEL 0	Current para. No./current positioning data								
7	RDY	PSET	CPU ready	ALM	Data error	Address error	-	-	-	-	-	-	-	-	Rewrite end	Read end	
8	Basic para., system para. setting (Low order word PC → Amplifier)																
9	Basic para., system para. setting (High order word PC → Amplifier)																
10	-																
11	-																
12	-																
13	-	-	-	-	-	-	-	-	-	-	-	-	-	-	-	-	
14	-					SEL2	SEL1	SEL0	Para. No. setting/positioning data setting								
15	RUN	FWD	REV	RST	START	ORG	X1	VEL0	VEL1	ABS INC	Position preset	-	-	-	Rewrite command	Read command	

• Basic parameter/system parameter

Word position	Setting range
Address 0 Address 1	Basic para. or system para. can be read out. There are no decimal point.
Address 2 to Address 5	(disable)
Address 6	The status of SEL2, SEL1 and SEL0 are stored (CSEL2 to CSEL0). The written para. No. is displayed (current positioning data).
Address 7	(information on each bit is always valid.)
Address 8 Address 9	The setting value of the para. to be changed will be written.
Address 10 to Address 13	(disable)
Address 14	Basic para. or system para. can be selected using SEL2 to SEL0. The para. No. to be changed can be set. Specify 01H to 63H in hexadecimal number (para./positioning data setting).
Address 15	Bit 0 is read command, and bit 1 is rewrite command (ON edge). (command of each bit is always valid.)

If a para. No. is specified at low order 8 bits of word +14, it is readed out at the ON edge of read command (word +15, bit 0) to words +1 and +0.

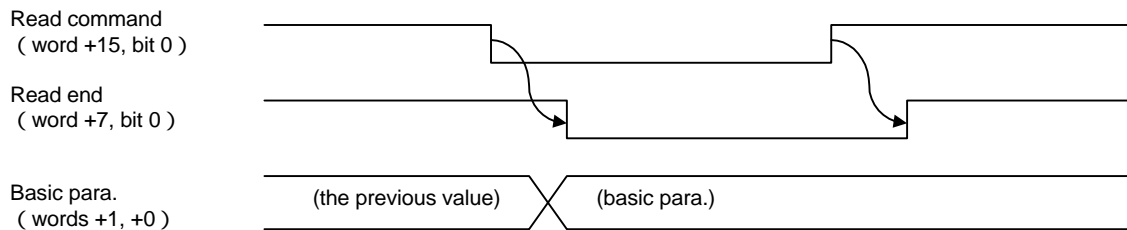

When read end signal turns on, basic para. has been settled.

If a para. No. is specified at low order 8 bits of word +14, it is rewritten at the ON edge of rewrite command (word +15, bit 1) to words +9 and +8.

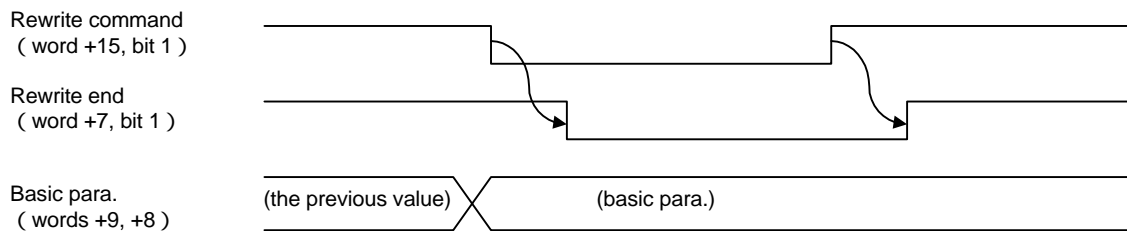

After rewrite end signal has turned on, data at words +9 and +8 may be changed.

Positioning data

Read out and rewrite of positioning data can be selected at on/off of SEL0, SEL1, SEL2.

This can be read out at the ON edge of the read command.

Read/rewrite data (select)

SEL2	SEL1	SEL0	IQ area (Upper line: 0 to 7W, Lower line: 8 to 15W)
ON	ON	OFF	Current positioning data
			Positioning data setting

Address	15	14	13	12	11	10	9	8	7	6	5	4	3	2	1	0
0	Current position data (Low order word PC Amplifier)															
1	Current position data (High order word PC Amplifier)															
2	Current speed data (Low order word PC Amplifier)															
3	Current speed data (High order word PC Amplifier)															
4	Current torque/current timer data (PC Amplifier)															
5	-	M code output form	M code valid, invalid	-	CEND	CO	ABS INC	Current M code								
6	-				CSEL 2	CSEL 1	CSEL 0	Current para. No./current positioning data								
7	RDY	PSET	CPU ready	ALM	Data error	Address error	-	-	-	-	-	-	-	-	Rewrite end	Read end
8	Position data setting (Low order word PC Amplifier)															
9	Position data setting (High order word PC Amplifier)															
10	Speed data setting (Low order word PC Amplifier)															
11	Speed data setting (High order word PC Amplifier)															
12	Timer data setting (PC Amplifier)															
13	-	M code output form	M code valid, invalid	-	CEND	CO	ABS INC	M code setting								
14	-				SEL2	SEL1	SEL0	Para. No. setting/positioning data setting								
15	RUN	FWD	REV	RST	START	ORG	X1	VEL0	VEL1	ABS INC	-	-	-	-	Rewrite command	Read command

• Positioning data

Word position	Setting range
Address 0	Positioning data is stored in 2 word.
Address 1	The min. value 1 is corresponds to unit quantity.
Address 2	Speed data is stored in 2 word.
Address 3	The min. value 1 is corresponds to 0.01 [r/min].
Address 4	Timer data is stored in 1 word. The min. value 1 is corresponds to 0.01 [s].
Address 5	The status (data continuation [CO] , cycle end [CEND], [ABS], [INC], M code valid) is stored. M code form is (0) simultaneous output [MW] and (1) later-output [MA]. M code is stored in low order.
Address 6	The status of SEL2, SEL1, SEL0 is stored (CSEL2 to CSEL0). Positioning data (current para./positioning data number ) can be stored.
Address 7	(information on each bit is always valid.)
Address 8	Position data can be set.
Address 9	The min. value 1 is corresponds to unit quantity.
Address 10	Speed data can be set.
Address 11	The min. value 1 is corresponds to 0.01 [r/min].
Address 12	Timer data can be set. The min. value 1 is corresponds to 0.01 [s].
Address 13	The status ([CO], [CEND], [ABS], [INC], M code valid) can be set. M code form is (0) [MW] and (1) [MA]. M code can be set in low order byte.
Address 14	Positioning data can be specified using SEL2, SEL1, SEL0.
Address 15	Bit 0 is read command and bit 1 is rewrite command (ON edge). (command of each bit is always valid.)

The timing of rewrite end and read end is as same as basic para. and sytem para..

Pulse value between LS-Z phase

The pulse value between LS-Z phase can be selected at on/off of SEL2, SEL1, SEL0.

This can be read out at the ON edge of the read command.

Read/rewrite data (select)

SEL2	SEL1	SEL0	IQ area (Upper line: 0 to 7W, Lower line: 8 to 15W)
ON	ON	ON	Current pulse value between LS-Z phase
			-

Address	15	14	13	12	11	10	9	8	7	6	5	4	3	2	1	0
0	Pulse value between LS-Z phase (Low order word PC ← Amplifier)															
1	Pulse value between LS-Z phase (High order word PC ← Amplifier)															
2	-															
3	-															
4	-															
5	-	-	-	-	-	-	-	-	-	-	-	-	-	-	-	-
6	-					CSEL 2	CSEL 1	CSEL 0	-							
7	RDY	PSET	CPU ready	ALM	Data error	Address error	-	-	-	-	-	-	-	-	Rewrite end	Read end
8	-															
9	-															
10	-															
11	-															
12	-															
13	-	-	-	-	-	-	-	-	-	-	-	-	-	-	-	-
14	-					SEL2	SEL1	SEL0	-							
15	RUN	FWD	REV	RST	START	ORG	X1	VEL0	VEL1	ABS INC	-	-	-	-	Rewrite command	Read command

• Pulse value between LS-Z phase

Word position	Setting range
Address 0 Address 1	Pulse value between LS-Z phase is stored in 2 word. The positive value only is allowed. The min. value 1 is corresponds to 1 [pulse].
Address 2 to Address 5	(disabled)
Address 6 Address 7	The status of SEL2, SEL1 and SEL0 is stored (CSEL2, CSEL1, CSEL0). (information on each bit is always valid.)
Address 8 to Address 13	(disabled)
Address 14 Address 15	Pulse value between LS-Z phase is specified using SEL2 to SEL0. Bit 0 is read command (ON edge). (command of each bit is always valid.)

The timing of rewrite end and read end is as same as basic para. and system para..

## 5.9 WB area

This section explains the WB area of RYS S3-LTS type.  
RYS S3-LTS type amplifier reserves 8 words in the WB area.

### (1) Station number

The station number setting of amplifier (system para. 96) determines the address in WB area. The changed setting of the system parameter is valid only after turning off and on power again.

### (2) Read/rewrite data

The lower order 4 words of WB area are the read out area, and the higher order 4 words are the write area.  
The data whether to read out or rewrite can be selected by on/off of bit 1 to 5 in word +5.

(3) CONT/OUT

The bit information at +0, +1 word and bit command at word +4, +5 position are valid in all the read/rewrite data status.

(4) Read command/rewrite command

To read data specified by the read/rewrite data select, turn on the read command at bit 7 in word +5 position. The read end at bit 7 in word +1 turned on, when reading is end.

To write data, turn on the rewrite command at bit 6 in word +5. The rewrite end at bit 6 in word +1 turns on when writing is end.

• WB area

Address	0	1	2	3	4	5	6	7	8	9	A	B	C	D	E	F	
+0	OUT 5	OUT 6	OUT 7	OUT 8	OUT 9	OUT 10	OUT 11	OUT 12	OUT 13	OUT 14	OUT 15	OUT 16	OUT 17	OUT 18	OUT 19	OUT 20	
+1	OUT 21	ALM4	ALM3	ALM2	ALM1	ALM0	Rewrite end	Read end	M code								
+2	Read data (High order word PC ← Amplifier)																
+3	Read data (Low order word PC ← Amplifier)																
+4	CONT 9	CONT 10	CONT 11	CONT 12	CONT 13	CONT 14	CONT 15	CONT 16	CONT 17	CONT 18	CONT 19	CONT 20	CONT 21	CONT 22	CONT 23	CONT 24	
+5	CONT 25	Read/rewrite data select					Rewrite command	Read command	Address No.								
+6	Rewrite data (High order word PC → Amplifier)																
+7	Rewrite data (Low order word PC → Amplifier)																

Read/rewrite data (select)

+1	+2	+3	+4	+5	WB area (when reading)	WB area (when rewriting)
OFF	OFF	OFF	OFF	OFF	Current feedback position	-
OFF	OFF	OFF	OFF	ON	Feedback speed	-
OFF	OFF	OFF	ON	OFF	Torque command	-
OFF	OFF	OFF	ON	ON	Deviation amount	-
OFF	OFF	ON	OFF	OFF	Pulse value between LS-Z phase	-
OFF	OFF	ON	OFF	ON	Status	Status
OFF	OFF	ON	ON	OFF	Position data	Position data
OFF	OFF	ON	ON	ON	Speed data	Speed data
OFF	ON	OFF	OFF	OFF	Timer data	Timer data
OFF	ON	OFF	OFF	ON	Basic para.	Basic para.
OFF	ON	OFF	ON	OFF	System para.	System para.
OFF	ON	OFF	ON	ON	-	-
OFF	ON	ON	OFF	OFF	-	-
OFF	ON	ON	OFF	ON	-	-
OFF	ON	ON	ON	OFF	Current command position	-
OFF	ON	ON	ON	ON	Command speed	-
ON	OFF	OFF	OFF	OFF	-	Speed command

(5) Immediate positioning

Position data can be written into position of WB area.

Preparation

Run command [RUN] (at bit 0 in word +4) turns on.

• Immediate positioning : See to of the table below.

: Set the position data to +6, +7 word.

: Select the rotational speed at VEL0, VEL1.

: Select the absolute position specified [ABS] or the relative position specified [INC] at position data.

: Set the "FF" to the address No. area.

: The motor starts rotation at the ON edge of [START] signal.

(6) Auto start : See and of the table below.

: Set the positioning data number in the address No. area.

: The motor starts rotation at the ON edge of [START] (at bit 1 in word +4) signal.

(7) Manual feed

The rotational speed at forward [FWD] and reverse [REV] command is specified by the speed command (see of the table below) while multistep speed selection [X1] is off.

Turn on the bit 1 in word +5 position only in the read/rewrite data select area.

After the rewrite command has been turned on, the speed is determined by (in 1 [r/min] step).

The [X1] is at bit A in word +4 (at factory setting) position.

• WB area (at factory setting)

Address	0	1	2	3	4	5	6	7	8	9	A	B	C	D	E	F	
+0	RDY	PSET	CPU ready	Alarm detect	Address error	+OT detect	-OT detect	LS detect	EMG detect	Data error	-	-	-	-	-	-	
+1	-	ALM4	ALM3	ALM2	ALM1	ALM0	Rewrite end	Read end	M code								
+2	Read data (High order word										PC ← Amplifier)						
+3	Read data (Low order word										PC ← Amplifier)						
+4	RUN	START	FWD	REV	ORG	EMG	RST	VELO	VEL1	ABS INC	X1	-	-	-	-	-	
+5	-	Read/rewrite data select					Rewrite command	Read command	Address No.								
+6	Rewrite data (High order word										PC → Amplifier)						
+7	Rewrite data (Low order word										PC → Amplifier)						

For the immediate start, this command is not needed.

Current value

The current value of various data can be selected at on/off of bit 1 to 5 in word +5.

The selected current value can be read out at the ON edge of read command at bit 7 in word +5 position.

Once the read command is turned on, the data can be read out continuously.

Read/rewrite data (select)

+1	+2	+3	+4	+5	WB area (when reading)	WB area (when rewriting)
OFF	OFF	OFF	OFF	OFF	Current feedback position	-
OFF	OFF	OFF	OFF	ON	Feedback speed	-
OFF	OFF	OFF	ON	OFF	Torque command	-
OFF	OFF	OFF	ON	ON	Deviation amount	-
OFF	OFF	ON	OFF	OFF	Pulse value between LS-Z phase	-
OFF	ON	OFF	ON	ON	-	-
OFF	ON	ON	OFF	OFF	-	-
OFF	ON	ON	OFF	ON	-	-
OFF	ON	ON	ON	OFF	Current command position	-
OFF	ON	ON	ON	ON	Command speed	-
ON	OFF	OFF	OFF	OFF	-	Speed command

Address	0	1	2	3	4	5	6	7	8	9	A	B	C	D	E	F	
+0	RDY	PSET	CPU ready	Alarm detect	Address error	+OT detect	-OT detect	LS detect	EMG detect	Data error	-	-	-	-	-	-	
+1	-	ALM4	ALM3	ALM2	ALM1	ALM0	Rewrite end	Read end	M code								
+2	Read data (High order word										PC ← Amplifier)						
+3	Read data (Low order word										PC ← Amplifier)						
+4	RUN	START	FWD	REV	ORG	EMG	RST	VEL0	VEL1	ABS INC	X1	-	-	-	-	-	
+5	-	Read/rewrite data select					Rewrite command	Read command	Address No.								
+6	Rewrite data (High order word										PC → Amplifier)						
+7	Rewrite data (Low order word										PC → Amplifier)						

The contents read out in word +2, +3 position are of BCD 8 digits or 32 bits binary (changeable by system para. 98).

• Current value

Data selection	Setting range
Current feedback position	Motor's current position is stored. The min. value 1 is corresponds to unit quantity.
Feedback speed	Current rotational speed is stored. The min. value 1 is corresponds to 1 [r/min].
Torque command	Current output torque is stored. The min. value 1 is corresponds to 1% of rated (100%) torque.
Deviation amount	Difference (deviation amount) between the current command position and the current feedback position is stored. The min. value 1 is corresponds to 1 [pulse].
Pulse value between LS-Z phase	At origin return, the pulse number is stored from when the origin LS [LS] signal is off, up to when the motor's Z-phase is detected. The min. value 1 is corresponds to 1 [pulse].
Current command position	Specified motor's current position is stored. The min. value 1 is corresponds to unit quantity.
Command speed	Specified motor's current speed is stored. The min. value 1 is corresponds to 1 [r/min].
Speed command (rewrite)	Rotational speed can be specified on [FWD]/[REV]. The min. value 1 is corresponds to 0.01 [r/min].

Parameter/positioning data

The basic para., system para. and positioning data can be edited at on/off status at bit 1 to 5 in word +5 position.

The parameter can be read out at the ON edge of read command at bit 7 in word +5 position.

The parameter can be rewritten at the ON edge of rewrite command at bit 6 in word + 5 position.

Specify the targeted para. No. and positioning data No. in the area of address number.

Read/rewrite data (select)

+1	+2	+3	+4	+5	WB area (when reading)	WB area (when rewriting)
OFF	OFF	ON	OFF	ON	Status	Status
OFF	OFF	ON	ON	OFF	Position data	Position data
OFF	OFF	ON	ON	ON	Speed data	Speed data
OFF	ON	OFF	OFF	OFF	Timer data	Timer data
OFF	ON	OFF	OFF	ON	Basic para.	Basic para.
OFF	ON	OFF	ON	OFF	System para.	System para.

Address	0	1	2	3	4	5	6	7	8	9	A	B	C	D	E	F	
+0	RDY	PSET	CPU ready	Alarm detect	Address error	+OT detect	-OT detect	LS detect	EMG detect	Data error	-	-	-	-	-	-	
+1	-	ALM4	ALM3	ALM2	ALM1	ALM0	Rewrite end	Read end	M code								
+2	Read data (High order word										PC ← Amplifier)						
+3	Read data (Low order word										PC ← Amplifier)						
+4	RUN	START	FWD	REV	ORG	EMG	RST	VEL0	VEL1	ABS INC	X1	-	-	-	-	-	
+5	-	Read/rewrite data select					Rewrite command	Read command	Address No.								
+6	Rewrite data (High order word										PC → Amplifier)						
+7	Rewrite data (Low order word										PC → Amplifier)						

Parameter/positioning data

Data selection	Setting range																																	
Basic para. System para	The data is read or written with the decimal point ignored.																																	
Positioning data Position data	Position data is read or written. The min. value 1 is corresponds to unit quantity.																																	
Positioning data Speed data	Speed data is read or written. The min. value 1 is corresponds to 0.01 [r/min]																																	
Positioning data Timer data	Timer data is read or written. The min. value 1 is corresponds to 0.01 [s].																																	
Positioning data Status	Status ([CO], [CEND], [ABS], [INC], M code valid) is stored. M code output form is (0) [MW] and (1) [MA]. M code is stored in +6 word low level byte.  <table border="1" style="margin-left: 40px;"> <thead> <tr> <th>Address</th> <th>6</th> <th>7</th> <th>8</th> <th>9</th> <th>A</th> <th>B</th> <th>C</th> <th>D</th> <th>E</th> <th>F</th> </tr> </thead> <tbody> <tr> <td>+6</td> <td>-</td> <td colspan="9">M code (00H to FFH)</td> </tr> <tr> <td>+7</td> <td>-</td> <td>-</td> <td>M code output form</td> <td>M code valid, invalid</td> <td>-</td> <td>-</td> <td>CEND</td> <td>CO</td> <td>ABS INC</td> <td></td> </tr> </tbody> </table>	Address	6	7	8	9	A	B	C	D	E	F	+6	-	M code (00H to FFH)									+7	-	-	M code output form	M code valid, invalid	-	-	CEND	CO	ABS INC	
Address	6	7	8	9	A	B	C	D	E	F																								
+6	-	M code (00H to FFH)																																
+7	-	-	M code output form	M code valid, invalid	-	-	CEND	CO	ABS INC																									

If a para. is specified at low order 8 bits of word +5, it is read out at the ON edge of read command (word +5, bit 7) to words +2 and +3.

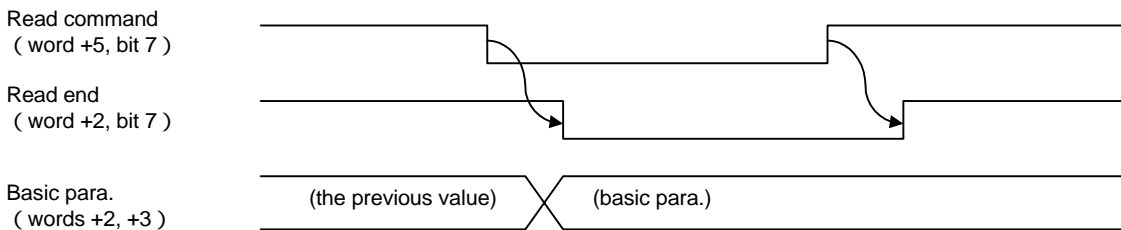

When read end signal turns on, basic para. has been settled.

If a para. is specified at low order 8 bits of word +5, data set at words +6 and +7 is rewritten at the ON edge of write command (word +5, bit 6).

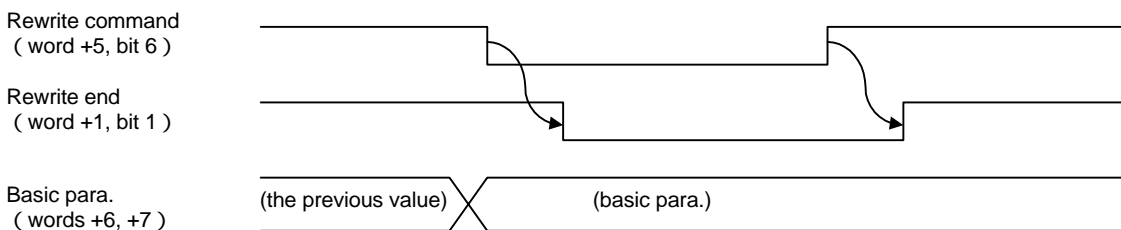

After write end signal has turned on, data at words +6 and +7 may be changed.

## 5.10 General-purpose communication

This section explains the transmission/reception command used for RYS S3-LRS type amplifier.

RYS S3-LRS type amplifier executes all the control action via serial communication.  
For the overview, see 4.4 Upper interface.

### (1) Station number

The station number of message (ADR) part can be set by the station number setting (system para. 96) of amplifier.  
Changed setting of system para. is valid only after turning off and on again.

### (2) Control input terminal (CONT1 to CONT8), control output terminal (OUT1 to OUT4)

The following signals are allocated to CONT1 to CONT8 and OUT1 to OUT4 terminals of the connector 1 (CN1).

(at factory shipment)

CN1	
Terminal symbol	Initial value
CONT1	Run command [RUN]
CONT2	Auto start [START]
CONT3	Origin LS [LS]
CONT4	+OT
CONT5	-OT
CONT6	Forced stop [EMG]
CONT7	-
CONT8	-

CN1	
Terminal symbol	Initial value
OUT1	Ready [RDY]
OUT2	Positioning end [PSET]
OUT3	-
OUT4	-

### (3) OUT5 to OUT12

The signals of OUT5 to OUT12 allocated to system para. 35 and later will be reflected to the message (ST2).

### (4) Response time

The response time of operation command is approx. 5 [ms] or less, and that of para. rewrite (max. 4) is approx. 20 [ms].  
The time period required from the command receive (from) amplifier to the response command send can be fixed by system para. 91 setting.

• Data read out from amplifier

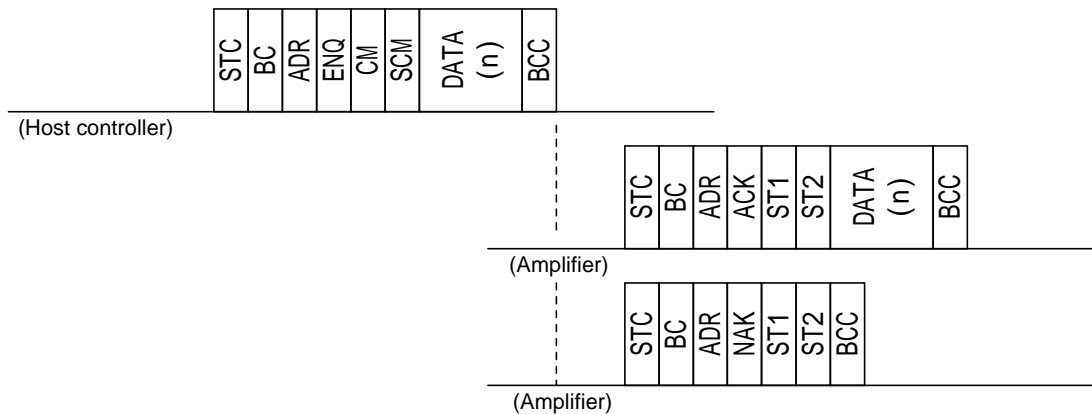

• Data write and operation command to amplifier

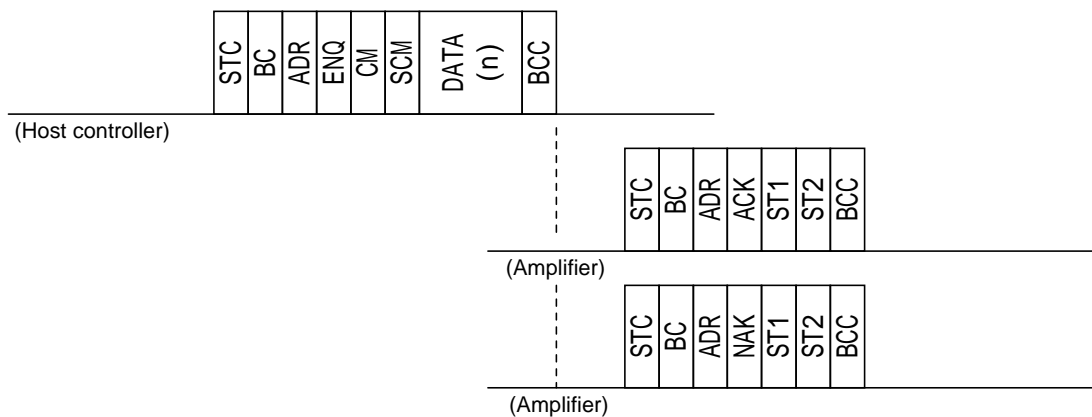

(5) Valid receive time

The valid time after receiving STC of a message up to receiving the last BCC (Block Check Code (Character)) is 0.5 [s] at factory shipment. Since a message contains 40 characters max., the message can be received in 0.046 [s] to its end.

$$40 \text{ character} \times 11\text{-bit} / 9600 \text{ [bps]} = 0.046 \text{ [s]}$$

If the BCC is not received within 0.5 [s], the message will be discarded.

The valid receive time can be set by system para. 92.

(6) Communication time over

The detection function of communication time over is invalid at factory shipment.

If a message cannot be received within a specified time, the operation command that the amplifier has already received is invalidated. (The control input signal to the connector 1 is valid)

If no command is transmitted from the host controller for a certain reason, the motor is set at initial status (any operation command has not been received yet).

In this case, the host controller may not receive the command even if amplifier responds. The following will be displayed in the station number display screen on the keypad panel.

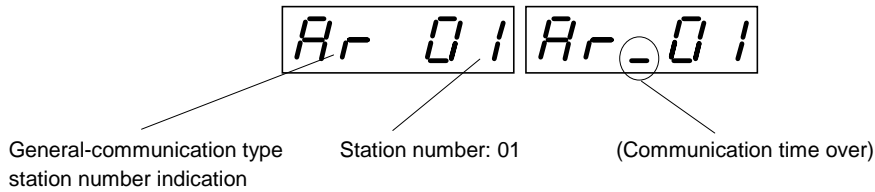

Receiving an arbitrary command makes resetting.

When the operation command (message) turns the run command [RUN] on, the run command [RUN] is turned off if the communication time over is detected. The motor is held at safety side (the status having no driving force).

The communication time over can be set by system para. 93.

Command

CM	SCM	DATA(n)		Function
		ENQ	ACK/NAK	
30H	30H	(2)	(6 to 18)	Reading out of monitored data
	31H	-	(5)	Reading out of the positioning data under execution
31H	30H	-	(3)	Reading out of sequence mode
	31H	-	(2)	Reading out of control input/output signal
	32H	-	(9)	Reading out of alarm detection history
	33H		(1)	Reading out of alarm detection contents
32H	30H	(2)	(4 to 16)	Reading out of basic para.
	31H	(2)	(4 to 16)	Reading out of system para.
	32H	(6 to 18)	-	Rewriting of basic para.
	33H	(6 to 18)	-	Rewriting of system para.
33H	30H	(2)	(12 to 24)	Reading out of positioning data
	31H	(14 to 25)	-	Rewriting of positioning data

## Command

CM	SCM	DATA (n)		Function
		ENQ	ACK/NAK	
34H	30H	-	-	Run command [RUN] off
	31H	-	-	Run command [RUN] on
	32H	(3)	-	Forward operation (immediate) on (DATA (n): specified speed value)
	33H	(1)	-	Forward operation (multistep speed) on (DATA (n): speed selection)
	34H	(3)	-	Reverse operation (immediate) on (DATA (n): specified speed value)
	35H	(1)	-	Reverse operation (multistep speed) on (DATA (n): speed selection)
	36H	-	-	Forward/reverse operation off (33H to 35H: cancel)
	37H	(6)	-	Setting of positioning data (immediate)
	38H	(1)	-	Setting of positioning data number
	39H	(6)	-	Auto start (immediate)
	3AH	(1)	-	Auto start (positioning data number)
	3BH	-	-	Origin return
	3CH	-	-	Release of forced stop
	3DH	-	-	Forced stop command
	3EH	-	-	Alarm reset
	3FH	(1)	-	Accel./decel. time selection (DATA (n): time selection)
	40H	-	-	Position preset
	41H	-	-	Pulse train ratio 1 off
	42H	-	-	Pulse train ratio 1 on
	43H	-	-	Pulse train ratio 2 off
	44H	-	-	Pulse train ratio 2 on
	45H	-	-	P-action off
	46H	-	-	P-action on
	47H	-	-	Current limiting off
	48H	-	-	Current limiting on
	49H	-	-	Temporary stop off
	4AH	-	-	Temporary stop on
	4BH	-	-	Positioning cancel (auto start, origin return)
	4CH	(1)	-	Teaching (Data (n): positioning data)
	4DH	-	-	Override off
	4EH	-	-	Override on
	4FH	(2)	-	Override scale factor selection (DATA (n): type and selection)
	50H	-	-	Interrupt valid off
	51H	-	-	Interrupt valid on
52H	-	-	Deviation clear off	
53H	-	-	Deviation clear on	
54H	-	-	Free-run off	
55H	-	-	Free-run on	
56H	-	-	Edit permit command off	
57H	-	-	Edit permit command on	
58H	-	-	Positive direction skip feed	
59H	-	-	Negative direction skip feed	
5AH	-	-	Alarm detection history initialization	
5BH	-	-	Status information	

Reading out of monitored data

CM 30H

SCM 30H

DATA (n)

Transmit from host controller

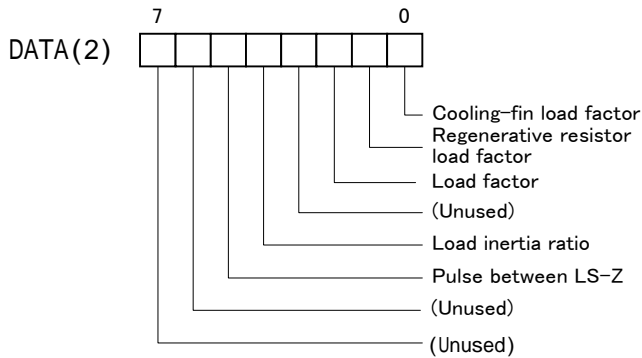
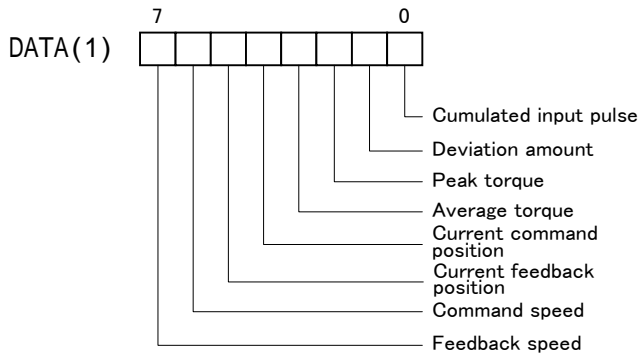
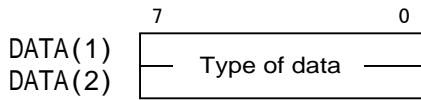

(Transmit from amplifier)

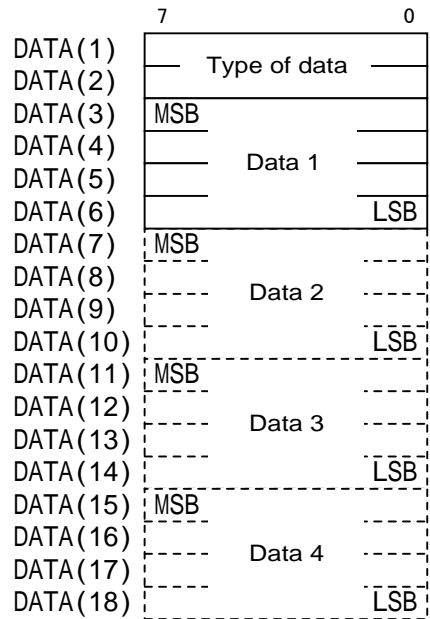

The data in which “1” is present among DATA(1) and DATA(2) is transmitted from amplifier.

Specify 28H at DATA(1) to obtain the current feedback position and average torque.

The monitor data is a 32-bit fixed-length data. If there are 2 monitor data, 10 bytes will be transmitted.

Up to 4 data to be monitored can be specified.

Each data is 32-bit fixed-length and transmitted in the following range.

Monitor item	Data (binary 32-bit fixed-length)	Priority
Cumulated input pulse	-2 <sup>32</sup> to 0 to 2 <sup>32</sup> [pulse]	8
Deviation amount	-2 <sup>32</sup> to 0 to 2 <sup>32</sup> [pulse]	7
Peak torque	-450 to 0 to 450% (rated torque 100%)	6
Average torque	-450 to 0 to 450% (rated torque 100%)	5
Current command position	-79999999 to 0 to 79999999 (x unit q'ty)	4
Current feedback position	-79999999 to 0 to 79999999 (x unit q'ty)	3
Command speed	-5000.00 to 0 to 5000.00 [r/min]	2
Feedback speed	-5000.00 to 0 to 5000.00 [r/min]	1
Cooling-fin load factor	0 to 100 [%]	13
Regenerative resistor load factor	0 to 100 [%]	12
Load factor	0 to 100 [%]	11
Load inertia ratio	1.5 times/180H (1.5 times load inertia at 180H)	10
Pulse between LS-Z	0 to 65535 [pulse] (16-bit serial encoder)	9

When 4 or more bits are "1", the data is transmitted in the order shown in the table.

ACK or NAK is returned from the amplifier.

- Read out from amplifier

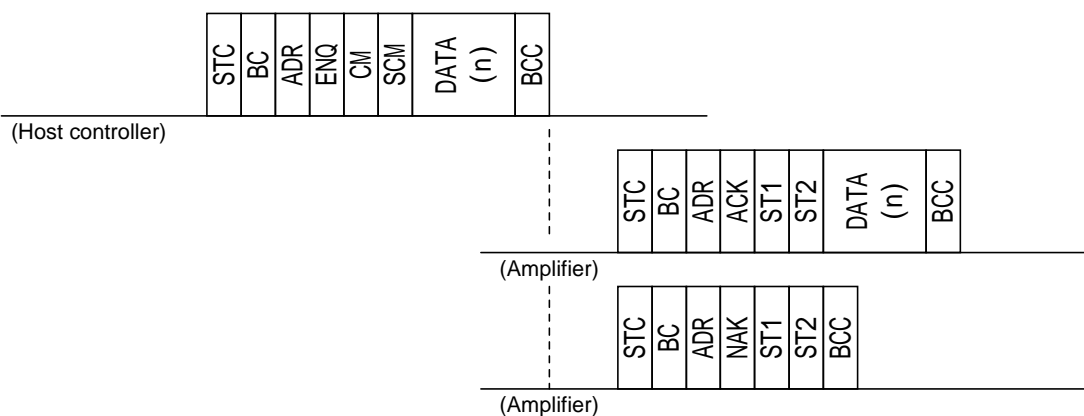

#### Transmission code

Code	Contents (HEX)	Function
STC	A5H (fixed)	Top code
BC	xxH (variable)	Byte counter : The number of bytes from ADR to BCC can be set.
ADR	01H to 1FH	Station number : The station number of 1 through 31 which identifies amplifiers can be set.
ENQ	05H (fixed)	Enquiry (request)
ACK	06H (fixed)	Acknowledgment (affirmative response)
NAK	15H (fixed)	Negative acknowledgment (negative response)
CM	xxH (variable)	Command : The command (instruction) to amplifier is specified.
SCM	xxH (variable)	Subcommand : Details of command (instruction) are specified.
DATA (n)	xxH (variable)	Data : Data attached to command
ST1	xxH (variable)	Status 1 : Data of transmission system is expressed in 8 bits.
ST2	xxH (variable)	Status 2 : The on/off of control output signal is expressed in 8 bits.
BCC	xxH (variable)	Check sum : The lower 8 bits including the contents from STC to immediate before BCC.

Reading out of the positioning data under execution

CM 30H

SCM 31H

DATA (n) Transmit from host controller  
(No data)

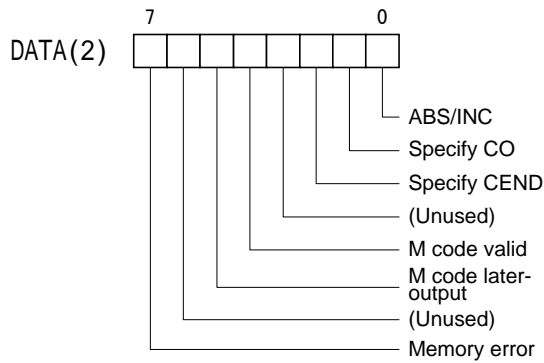

Transmit from amplifier

	7	0
DATA(1)	Positioning data number under execution	
DATA(2)	Status	
DATA(3)	MSB	_____
DATA(4)	Position data	
DATA(5)	_____	
DATA(6)	LSB	
DATA(7)	MSB	_____
DATA(8)	Speed data	
DATA(9)	_____	
DATA(10)	LSB	
DATA(11)	MSB	_____
DATA(12)	Current position data	
DATA(13)	_____	
DATA(14)	LSB	
DATA(15)	M code	

Reading out of sequence mode

CM 31H

SCM 30H

DATA (n) Transmit from host controller  
(No data)

Transmit from amplifier

	7	0
DATA(1)	Control mode	
DATA(2)	Mode	
DATA(3)	Sub-mode	

Control mode

Data	Control mode
00H	Position control
01H	Speed control
02H	Torque control

Mode

Data	Mode
00H	Base-off
01H	Rotation possible
02H	OT detection
03H	Forced stop
04H	Free-run command

Sub-mode (mode 01H)

Data	Sub-mode
00H	Standby (waiting rotational command)
04H	
08H	
01H	During manual operation (FWD/REV)
05H	
10H	
02H	Brake release
06H	
14H	
03H	Brake operate
07H	
15H	
11H	Interrupt positioning
12H	Origin return
13H	Deviation clear

Sub-mode (mode 02H)

Data	Sub-mode
00H	Speed zero
01H	Standby (waiting rotational command)
05H	
02H	During manual operation (FWD/REV)
07H	
03H	Brake release
08H	
04H	Brake operate
09H	
06H	Pulse train input

Sub-mode (mode 00, 03, 04H)

Data	Sub-mode
00H	Speed zero

Reading out of control input/output signal

CM 31H

SCM 31H

DATA (n) Transmit from host controller  
No data

Transmit from amplifier

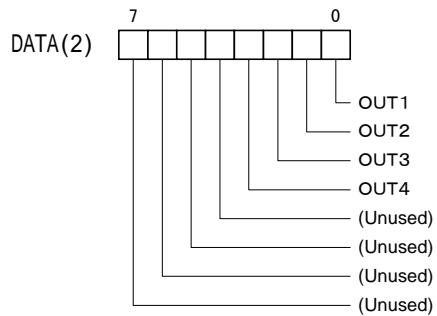
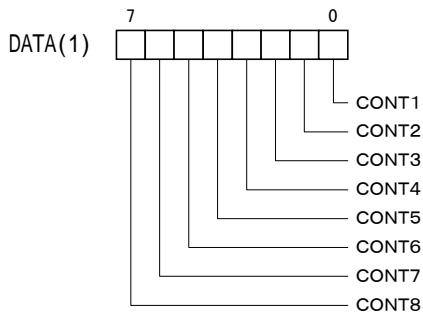
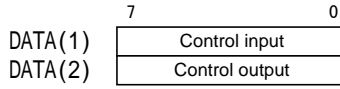

Reading out of alarm detection history

CM 31H

SCM 32H

DATA (n) Transmit from host controller  
(No data)

Transmit from amplifier

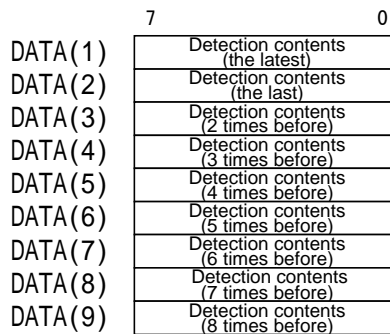

Major fault detection

Code	Name
1FH	System error
06H	Overcurrent
07H	Overspeed
09H	Undervoltage
08H	Overvoltage
0AH	Encoder trouble
0CH	Circuit trouble
0DH	Data error
0FH	Fuse blown
13H	Combination error
12H	Resistor heat 2
11H	Encoder communication error
14H	Control signal error
01H	Overload

Minor fault detection

Code	Name
04H	Resistor heat
05H	Overflow
03H	Amp heat
14H	Encoder heat
15H	Absolute data lost
16H	Absolute data overflow
17H	Terminal error

No detection

Code	Name
00H	(No detection)

Reading out of alarm detection contents

CM 31H

SCM 33H

DATA (n) Transmit from host controller  
(No data)

Transmit from amplifier

DATA(1) 

7	0
Detection contents (latest)	

(\*) For the detection contents, see SCM 32H.

Reading out of basic para.  
Reading out of system para.

CM 32H

SCM 30H (basic para.)  
31H (system para.)

Up to 4 consecutive basic para. (system para.)  
beginning from para. No. can be read out.

DATA (n) Transmit from host controller

7	0
DATA(1)	No. of data read-out
DATA(2)	Parameter No.

Transmit from amplifier

7	0
DATA(1)	MSB
DATA(2)	Data 1
DATA(3)	Data 1
DATA(4)	LSB
DATA(5)	MSB
DATA(6)	Data 2
DATA(7)	Data 2
DATA(8)	LSB
DATA(9)	MSB
DATA(10)	Data 3
DATA(11)	Data 3
DATA(12)	LSB
DATA(13)	MSB
DATA(14)	Data 4
DATA(15)	Data 4
DATA(16)	LSB

Rewriting of basic para.  
 Rewriting of system para.

CM

**32H**

SCM

**32H** (basic para.)  
**33H** (system para.)

Up to 4 consecutive basic para. (system para.)  
 beginning from para. No. can be rewritten.

DATA  
(n)

Transmit from host controller

	7	0
DATA(1)	No. of data read-out	
DATA(2)	Parameter No.	
DATA(3)	MSB	_____
DATA(4)	_____	_____
DATA(5)	Data 1	
DATA(6)	_____	LSB
DATA(7)	MSB	-----
DATA(8)	-----	-----
DATA(9)	Data 2	
DATA(10)	-----	LSB
DATA(11)	MSB	-----
DATA(12)	-----	-----
DATA(13)	Data 3	
DATA(14)	-----	LSB
DATA(15)	MSB	-----
DATA(16)	-----	-----
DATA(17)	Data 4	
DATA(18)	-----	LSB

Transmit from amplifier

(No data)

Reading out of positioning data

CM 33H

SCM 30H

DATA (n) Transmit from host controller

DATA(1)	7	No. of data read-out	0
DATA(2)		Positioning data No.	

The No. of data read-out is 01H or 02H.  
Specify the positioning data No. to be read-out first at 01H through 63H.

Up to 2 consecutive positioning data beginning from positioning data No. can be read-out.

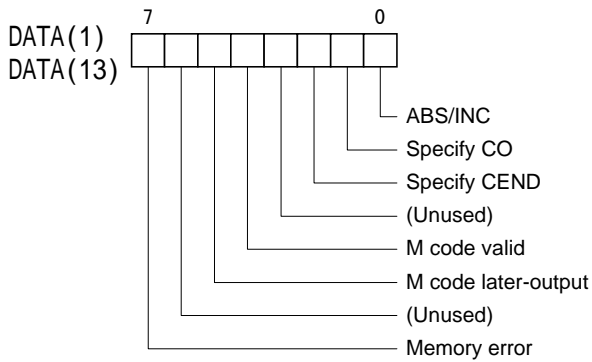

Transmit from amplifier

DATA(1)	7	Status	0
DATA(2)	MSB		
DATA(3)		Position data	
DATA(4)			
DATA(5)			LSB
DATA(6)	MSB		
DATA(7)		Speed data	
DATA(8)			
DATA(9)			LSB
DATA(10)	MSB	Timer data	
DATA(11)			LSB
DATA(12)		M code	
DATA(13)		Status	
DATA(14)	MSB		
DATA(15)		Position data	
DATA(16)			
DATA(17)			LSB
DATA(18)	MSB		
DATA(19)		Speed data	
DATA(20)			
DATA(21)			LSB
DATA(22)	MSB	Timer data	
DATA(23)			LSB
DATA(24)		M code	

Rewriting of positioning data

CM 33H

SCM 31H

DATA (n)	Transmit from host controller	
	7	0
DATA(1)	No. of data to be rewritten	
DATA(2)	Positioning data No.	
DATA(3)	Status	
DATA(4)	MSB	
DATA(5)		Position data
DATA(6)		
DATA(7)		LSB
DATA(8)	MSB	
DATA(9)		Speed data
DATA(10)		
DATA(11)		LSB
DATA(12)	MSB	Timer data
DATA(13)		LSB
DATA(14)	M code	
DATA(15)	Status	
DATA(16)	MSB	
DATA(17)		Position data
DATA(18)		
DATA(19)		LSB
DATA(20)	MSB	
DATA(21)		Speed data
DATA(22)		
DATA(23)		LSB
DATA(24)	MSB	Timer data
DATA(25)		LSB
DATA(26)	M code	

Up to 2 consecutive positioning data beginning from positioning data No. can be rewritten.

Transmit from amplifier

There are no DATA (n).  
ACK or NAK returns.

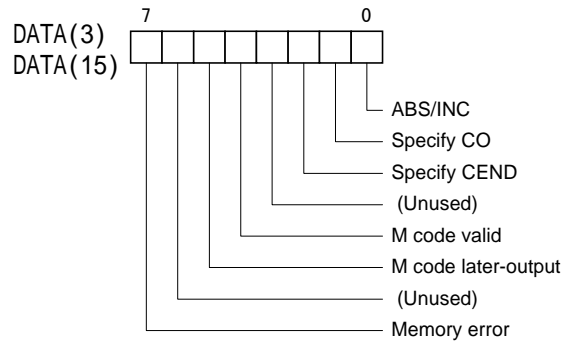

Run command [RUN]

CM	<b>34H</b>	Turns off and on the run command [RUN] signal from amplifier.
SCM	<b>30H</b> Run command [RUN] off <b>31H</b> Run command [RUN] on	
DATA (n)	Transmit from host controller	Transmit from amplifier
	There are no DATA (n).	There are no DATA (n). ACK or NAK returns.

The run command [RUN] signal from amplifier can be turned off and on by the command  
The run command has been allocated to a control input signal at factory shipment.  
Turn on the run command to run the motor.

Forward operation [FWD]/Reverse operation [REV]

CM	<b>34H</b>	Turns off and on the forward operation [FWD] and reverse operation [REV] signals from amplifier. SCM 36H is the cancel command of from 32H to 35H.																	
SCM	<b>32H</b> Forward operation (immediate) on <b>33H</b> Forward operation (multistep speed) on <b>34H</b> Reverse operation (immediate) on <b>35H</b> Reverse operation (multistep speed) on <b>36H</b> Forward / reverse operation off																		
DATA (n)	Transmit from host controller	Transmit from amplifier																	
	<b>32H</b> Forward operation (immediate) on <b>34H</b> Reverse operation (immediate) on <table border="1" style="margin-left: 20px;"> <tr> <td style="width: 100px;">DATA(1)</td> <td style="text-align: center;">7</td> <td style="text-align: center;">0</td> </tr> <tr> <td></td> <td style="text-align: center;">MSB</td> <td style="text-align: center;">_____</td> </tr> <tr> <td>DATA(2)</td> <td style="text-align: center;">_____</td> <td style="text-align: center;">Speed data</td> </tr> <tr> <td>DATA(3)</td> <td style="text-align: center;">_____</td> <td style="text-align: center;">LSB</td> </tr> </table> <b>33H</b> Forward operation (multistep speed) on <b>35H</b> Reverse operation (multistep speed) on <table border="1" style="margin-left: 20px;"> <tr> <td style="width: 100px;">DATA(1)</td> <td style="text-align: center;">7</td> <td style="text-align: center;">0</td> </tr> <tr> <td></td> <td colspan="2" style="text-align: center;">_____</td> </tr> </table> <b>36H</b> Forward / reverse operation off  There are no DATA (n).	DATA(1)	7	0		MSB	_____	DATA(2)	_____	Speed data	DATA(3)	_____	LSB	DATA(1)	7	0		_____	
DATA(1)	7	0																	
	MSB	_____																	
DATA(2)	_____	Speed data																	
DATA(3)	_____	LSB																	
DATA(1)	7	0																	
	_____																		

Positioning data (immediate) setting

CM 34H

SCM 37H

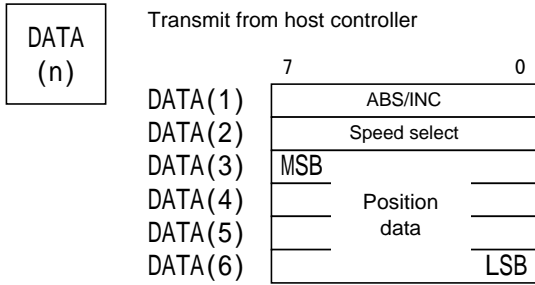

Transmit from amplifier

There are no DATA (n).  
ACK or NAK returns.

Position data  
Specify in 4 words regardless of the decimal point of unit quantity.  
For 799999.99, HEX value 04C4B3FFH of 79999999D can be set.

ABS/INC

Data	Control mode
00H	Absolute position (ABS)
01H	Relative position (INC)

Speed select

Data	Mode
00H	Positioning speed 1
01H	Positioning speed 2
02H	Positioning speed 3
03H	Positioning speed 4

Setting of positioning data number

CM 34H

SCM 38H

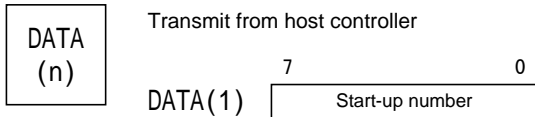

Transmit from amplifier

There are no DATA (n).

Start-up number  
Specify the positioning data number with 01H to 63H.  
Specify 63H to specify the positioning data number 99.

Positioning data (immediate) data can be set in SCM 37H, and positioning data in SCM 38H. This setting is for the case that the auto start [START] is allocated as control input signal. The start-up can be made by the data that were transmitted lastly by 37H and 38H. The start-up command of immediate positioning is at SCM 39H, the automatic start-up command of the positioning data is at 3AH.

Auto start (immediate)

Immediate positioning can be executed by command transmission.

CM 34H

SCM 39H

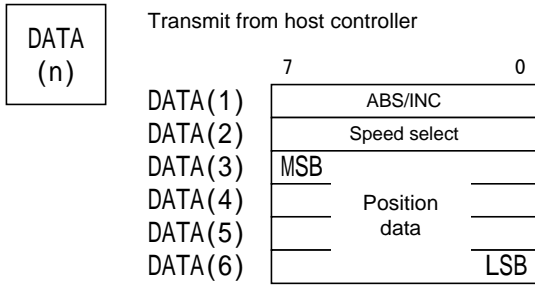

Transmit from amplifier

There are no DATA (n).  
ACK or NAK returns.

Position data  
Specify in 4 words regardless of the decimal point of unit quantity.  
For -799999.99, HEX value FB3B4C01H of 79999999D can be set.

ABS/INC

Data	Control mode
00H	Absolute position (ABS)
01H	Relative position (INC)

Speed select

Data	Mode
00H	Positioning speed 1
01H	Positioning speed 2
02H	Positioning speed 3
03H	Positioning speed 4

Auto start (Positioning data)

The motor rotates according to the positioning data setting upon command transmission.

CM 34H

SCM 3AH

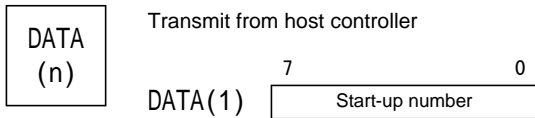

Transmit from amplifier

There are no DATA (n).  
ACK or NAK returns.

Start-up number  
Specify the positioning data number with 01H to 63H.  
Specify 01H to specify the positioning data number 1.

Origin return

Origin return action starts by command transmission.

CM

34H

SCM

3BH

DATA  
(n)

Transmit from host controller  
There are no DATA (n).

Transmit from amplifier  
There are no DATA (n).  
ACK or NAK returns.

Forced stop

Forced stop can be released or executed by command transmission.

CM

34H

SCM

3CH Forced stop release  
3DH Forced stop command

DATA  
(n)

Transmit from host controller  
There are no DATA (n).

Transmit from amplifier.  
There are no DATA (n).  
ACK or NAK returns.

- Forced stop command (station No.1)

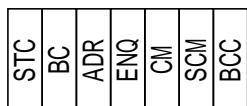

(Host controller)

Transmission code  
(forced stop command)

Code	Contents (HEX)
STC	A5H (fixed)
BC	05H
ADR	01H
ENQ	05H (fixed)
CM	34H
SCM	3DH
BCC	21H



Pulse train ratio 1, 2/P-action/Current limiting/Temporary stop

CM	<b>34H</b>	Each signal can be set off or on.
SCM	<b>41H</b> Pulse train ratio 1 off <b>42H</b> Pulse train ratio 1 on <b>43H</b> Pulse train ratio 2 off <b>44H</b> Pulse train ratio 1 on <b>45H</b> P-action off <b>46H</b> P-action on <b>47H</b> Current limiting off <b>48H</b> Current limiting on <b>49H</b> Temporary stop off <b>4AH</b> Temporary stop on	
DATA (n)	Transmit from host controller  There are no DATA (n).	Transmit from amplifier  There are no DATA (n). ACK or NAK returns.

Positioning cancel

The positioning action (origin return, auto start) under execution can be canceled.  
 This signal is invalid for the pulse train and forward/reverse command.

CM	<b>34H</b>	
SCM	<b>4BH</b>	
DATA (n)	Transmit from host controller  There are no DATA (n).	Transmit from amplifier  There are no DATA (n). ACK or NAK returns.

The current position at the command transmission can be stored in the position data of the specified positioning data.

CM	<b>34H</b>	
SCM	<b>4CH</b>	
DATA (n)	Transmit from host controller  DATA(1) <span style="border: 1px solid black; padding: 2px 10px; display: inline-block; text-align: center;">                     7 <span style="margin-left: 20px;">0</span>                      Positioning data No.                 </span>	Transmit from amplifier  There are no DATA (n). ACK or NAK returns.
	Positioning data No. Specify the positioning data number with 01H to 63H. Specify 01H to specify the positioning data No.1.	

Override

CM

34H

Specifies the override.  
The scale factor can be specified by the para. setting or numerical value.

SCM

- 4DH Override off
- 4EH Override on
- 4FH Override scale factor select

DATA (n)

Transmit from host controller

- 4DH Override off
- 4EH Override on

Transmit from amplifier

There are no DATA (n).  
ACK or NAK returns.

There are no DATA (n).

- 4FH Override scale factor select

DATA(1)	7	0
	Type of data	
DATA(2)	Setting value	

Type of data

Data	Control mode
00H	Direct specifying
01H	Parameter

Setting value (type of data 00H)

Data	Override
00H to 96H	0 to 150% (in 1 step)

Setting value (type of data 01H)

Data	Override
00H	0%
01H	Override 1
02H	Override 2
03H	Override 1+2
04H	Override 4
05H	Override 1+4
06H	Override 2+4
07H	Override 1+2+4
08H	Override 8
09H	Override 1+8
0AH	Override 2+8
0BH	Override 1+2+8
0CH	Override 4+8
0DH	Override 1+4+8
0EH	Override 2+4+8
0FH	Override 1+2+4+8

Interrupt valid/Deviation clear/Free-run/Edit permit ON

CM

34H

Each signal can be set to off or on.

SCM

- 50H Interrupt valid off
- 51H Interrupt valid on
- 52H Deviation clear off
- 53H Deviation clear on
- 54H Free-run off
- 55H Free-run on
- 56H Edit permit command off
- 57H Edit permit command on

DATA (n)

Transmit from host controller

There are no DATA (n).

Transmit from amplifier

There are no DATA (n).  
ACK or NAK returns.

Skip feed

A specified constant distance can be fed per command transmit. The feed amount can be set by basic para. 82, and the feed speed by basic para. 83.

CM	<b>34H</b>	The motor rotates for a specified constant amount.
SCM	<b>58H</b> Positive direction skip feed <b>59H</b> Negative direction skip feed	
DATA (n)	Transmit from host controller	Transmit from amplifier
	There are no DATA (n).	There are no DATA (n). ACK or NAK returns.

Initialization of alarm detection history

The alarm detection history can be initialized. The initializing status can be checked by bit 3 of ST1.

CM	<b>34H</b>	The alarm detection history can be initialized.
SCM	<b>5AH</b>	
DATA (n)	Transmit from host controller	Transmit from amplifier
	There are no DATA (n).	There are no DATA (n). ACK or NAK returns.

Status information

CM	<b>34H</b>	The status information (ST1, ST2) can be received.
SCM	<b>5BH</b>	
DATA (n)	Transmit from host controller	Transmit from amplifier
	There are no DATA (n).	There are no DATA (n). ACK or NAK returns.

## 6. PARAMETER SETTING

### About parameter

There are two types of parameters; basic parameter and system parameter.

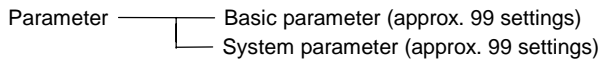

Set the parameters according to the motor usage and mechanical equipment system.

#### Basic parameter

The basic parameters are rather frequently adjusted, such as acceleration/deceleration time and manual feed speed.  
Changed setting of most basic parameters immediately affects the amplifier and the motor actions.

#### ■ System parameter

The system parameters are not frequently changed once they are set, such as function allocation to control input/output terminal and offset adjustment.  
Changed setting of most system parameters is valid only after turning off and on power.

Make sure that the keypad panel indication (7-segment) goes off when power is turned off.

Because the contents of parameter setting are stored in rewritable ROM (EEPROM), they cannot be lost even if power is turned off.  
Specific basic parameters can be stored in RAM and rewritable infinitely.

The parameters can be edited by the keypad panel and personal computer loader, etc.

For SX bus connection type amplifier, all the parameters can be edited from IQ area.

For T-link connection type amplifier, all the parameters can be edited from WB area.

For RS485 interface type amplifier, all the parameters can be edited by the commands.

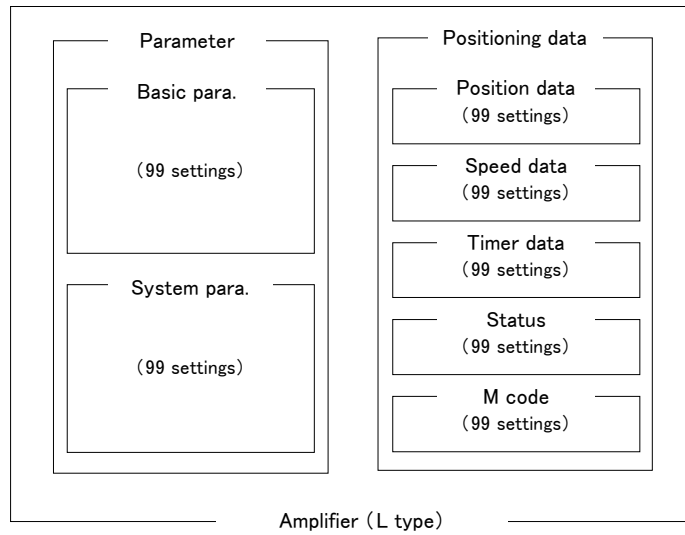

## 6.1 List of parameter

### (1) Basic parameter

The basic parameters are common to all types of the amplifiers.

Basic type (RYS□□□S3-LPS□ type)

SX bus type (RYS□□□S3-LSS□ type)

T-link type (RYS□□□S3-LTS□ type)

RS485 interface type (RYS□□□S3-LRS□ type)

The basic parameters are rather frequently adjusted.

Basic parameter for RYS-L type (1/2)		[Basic type/SX bus type/T-link type/RS485 interface type]		
Para.	Name	Setting range	Initial value	Change
01	Manual feed speed 1	0.01 to max. speed [r/min] (in 0.01 step)	100.00	Always
02	Manual feed speed 2	0.01 to max. speed [r/min] (in 0.01 step)	500.00	Always
03	Manual feed speed 3	0.01 to max. speed [r/min] (in 0.01 step)	1000.00	Always
04	Manual feed speed 4	0.01 to max. speed [r/min] (in 0.01 step)	100.00	Always
05	Manual feed speed 5	0.01 to max. speed [r/min] (in 0.01 step)	100.00	Always
06	Manual feed speed 6	0.01 to max. speed [r/min] (in 0.01 step)	100.00	Always
07	Manual feed speed 7	0.01 to max. speed [r/min] (in 0.01 step)	100.00	Always
08	Positioning speed 1	0.01 to max. speed [r/min] (in 0.01 step)	10.00	Always
09	Positioning speed 2	0.01 to max. speed [r/min] (in 0.01 step)	50.00	Always
10	Positioning speed 3	0.01 to max. speed [r/min] (in 0.01 step)	100.00	Always
11	Positioning speed 4	0.01 to max. speed [r/min] (in 0.01 step)	500.00	Always
12 to 15	Unused	-	0	-
16	Maximum speed	0.01 to max. speed [r/min] (in 0.01 step)	5000.00	Always
17	Override 1	0 to 150% (in 1 step)	10	Always
18	Override 2	0 to 150% (in 1 step)	20	Always
19	Override 4	0 to 150% (in 1 step)	40	Always
20	Override 8	0 to 150% (in 1 step)	80	Always
21	Acceleration time 1	0.000 to 99.999 [s] (in 0.001 step)	0.100	Always
22	Deceleration time 1	0.000 to 99.999 [s] (in 0.001 step)	0.100	Always
23	Acceleration time 2	0.000 to 99.999 [s] (in 0.001 step)	0.500	Always
24	Deceleration time 2	0.000 to 99.999 [s] (in 0.001 step)	0.500	Always
25	Non-linear (S-curve) filter coefficient	0.000 to 1.000 [s] (in 0.001 step)	0.000	Always
26 to 30	Unused	-	-	-
31	Tuning method	0: Manual 1: Auto (low stiffness) 2: Auto (high stiffness)	1	Always
32	Load inertia ratio	0.0 to 100.0 times (in 0.1 step)	0.0	Always
33	Operation speed response	10 to 1000 [Hz] (in 1 step)	100	Always
34	Speed response at stoppage	10 to 1000 [Hz] (in 1 step)	100	Always
35	Stop detection width	5 to 100 [r/min] (in 1 step)	20	Always
36	Stop judgment time	0.00 to 1.00 [s] (in 0.01 step)	0.00	Always
37	Torque filter time constant	0.00 to 20.00 [ms] (in 0.01 step)	0.00	Always
38	Speed regulator integration time	1 to 1000 [ms] (in 1 step)	20	Always
39	Position regulator gain	1 to 500 (in 1 step)	50	Always
40	Feed forward gain	0.000 to 1.500 (in 0.001 step)	0.000	Always
41	Speed setting filter	0.0 to 20.0 [ms] (in 0.1 step)	0.0	Always
42	Speed feedback filter	0: OFF 1: ON	0	Always
43	Unused	-	-	-
44	Vibration suppression time constant	10 to 1000 [ms] (in 1 step)	100	Always
45	Vibration suppression gain	0.00 to 1.00 (in 0.01 step)	0.00	Always

## Basic parameter for RYS-L type (2/2)

[Basic type/SX bus type/T-link type/RS485 interface type]

Para.	Name	Setting range	Initial value	Change
46 to 50	Unused	-	-	-
51	Speed matching zone (width)	10 to max. speed [r/min] (in 1 step)	50	Always
52	Speed zero width	10 to max. speed [r/min] (in 1 step)	20	Always
53	Deviation zero width	10 to 10000 [pulse] (in 1 step)	200	Always
54	Deviation excessive width	10 to 65535 (in 1 step) [x 100 pulse]	10000	Always
55	Positioning end output form	0: Level      1: One shot	0	Power
56	Positioning end output time	0.01 to 1.00 [s] (in 0.01 step)	0.10	Always
57	Positioning end judgment time	0.000 to 1.000 [s] (in 0.001 step)	0.050	Always
58	Overload early warning level	10 to 100% (in 1 step)	50	Always
59	Maximum torque limit level	0 to max. torque [%] (in 1 step)	300	Always
60 to 61	Unused	-	0	-
62	Fixed, passing point detection	0: Fixed point    1: Passing point OFF/ON 2: Passing point ON/OFF	0	Always
63	Fixed, passing point detection position 1	-79999999 to 0 to 79999999 (in 1 step) [x unit q'ty]	0	Always
64	Fixed, passing point detection position 2	-79999999 to 0 to 79999999 (in 1 step) [x unit q'ty]	0	Always
65	Fixed position detection range	0 to 79999999 (in 1 step) [x unit q'ty]	100	Always
66	Origin detection range	1 to 79999999 (in 1 step) [x unit q'ty]	100	Always
67 to 70	Unused	-	0	-
71	Origin return pattern	1: Pattern 1    2: Pattern 2    3: Pattern 3    4: Pattern 4	1	Power
72	Origin return direction	0: Positive direction    1: Negative direction	0	Power
73	Z-phase detection valid/invalid	0: Valid    1: Invalid	0	Power
74	Origin LS logic	0: NO contact    1: NC contact	0	Always
75	Origin return speed	0.01 to max. speed [r/min] (in 0.01 step)	500.00	Always
76	Origin detection creep speed	0.01 to max. speed [r/min] (in 0.01 step)	50.00	Always
77	Origin shift quantity	1 to 2000000 (in 1 step) [x unit q'ty]	1000	Always
78	Origin return reversing quantity	0 to 79999999 (in 1 step) [x unit q'ty]	0	Always
79	Origin return position	-79999999 to 0 to 79999999 (in 1 step) [x unit q'ty]	0	Always
80	Preset position	-79999999 to 0 to 79999999 (in 1 step) [x unit q'ty]	0	Always
81	Interrupt move amount	1 to 79999999 (in 1 step) [x unit q'ty]	100000	Always
82	Skip feed quantity	1 to 79999999 (in 1 step) [x unit q'ty]	2000	Always
83	Skip feed speed	0.01 to max. speed [r/min] (in 0.01 step)	100.00	Always
84	+ Limiter detection position	-79999999 to 0 to 79999999 (in 1 step) [x unit q'ty]	79999999	Always
85	- Limiter detection position	-79999999 to 0 to 79999999 (in 1 step) [x unit q'ty]	-79999999	Always
86	Backlash correction	0 to 10000 [pulse] (in 1 step)	0	Always
87 to 90	Unused	-	0	-
91	Command pulse correction	1 to 32767 (in 1 step)	8	Always
92	Command pulse correction	1 to 32767 (in 1 step)	1	Always
93	Pulse train ratio 1	0.01 to 100.00 (in 0.01 step)	1.00	Always
94	Pulse train ratio 2	0.01 to 100.00 (in 0.01 step)	10.00	Always
95	Position data decimal point position	0: 1    1: 0.1    2: 0.01    3: 0.001    4: 0.0001 5: 0.00001	0	0
96 to 99	Unused	-	0	-

## (2) System parameter

The system parameter is used for storing such data as the function setting of the control input/output terminals of amplifier.  
Changed setting of most system parameters is effective only after turning off and on power.

System parameter for basic type amplifier

Function (input signal) number assigned to  
system para.1 to 13 (CONT1 to CONT13)

Function (output signal) assigned to  
system para. 31 to 40 (OUT1 to OUT10)

0: Not assigned	32: Positioning cancel	0: Not assigned	30: Data error
1: Run command [RUN]	34: External fault input	1: Ready [RDY]	31: Address error
2: Forward command [FWD]	35: Teaching	2: Positioning end [PSET]	32: Alarm code 0
3: Reverse command [REV]	39: Immediate rewrite	13: Rewrite end	33: Alarm code 1
4: Auto start [START]	40: Immediate data selection 1	14: Brake timing	34: Alarm code 2
5: Origin return [ORG]	41: Immediate data selection 2	15: Dynamic braking	35: Alarm code 3
6: Origin LS [LS]	43: Override valid	16: Alarm detection [ALM]	36: Alarm code 4
7: +OT [+OT]	44: Override 1	17: Fixed, passing point 1	38: +OT detection
8: -OT [-OT]	45: Override 2	18: Fixed, passing point 2	39: -OT detection
9: ABS/INC	46: Override 4	19: Limiter detection	40: Origin LS detection
10: Forced stop [EMG]	47: Override 8	20: OT detection	41: Forced stop detection
11: Alarm reset [RST]	48: Interrupt valid	21: Cycle end [CEND]	60: MD0
12: VEL0	49: Interrupt input	22: Origin return end	61: MD1
13: VEL1	50: Deviation clear	23: Deviation zero	62: MD2
14: ACC0	51: Multistep speed X1 [X1]	24: Speed zero [NZERO]	63: MD3
16: Position preset	52: Multistep speed X2 [X2]	25: Speed arrive [NARV]	64: MD4
27: Pulse train ratio 1	53: Multistep speed X3 [X3]	26: Torque limit detection	65: MD5
28: Pulse train ratio 2	54: Free-run [BX]	27: Overload early warning	66: MD6
29: P-action	55: Edit permit command	28: CPU ready [CPURDY]	67: MD7
30: Torque limit	56: Current position output	29: Edit permit ON/OFF	75: Position preset end
31: Temporary stop			

System parameter for RYS-L type (1/2)

[Basic type]

Para.	Name	Setting range	Initial value	Change
01	CONT1 signal assignment	0 to 56 (in 1 step)	1	Power
02	CONT2 signal assignment	0 to 56 (in 1 step)	2	Power
03	CONT3 signal assignment	0 to 56 (in 1 step)	3	Power
04	CONT4 signal assignment	0 to 56 (in 1 step)	11	Power
05	CONT5 signal assignment	0 to 56 (in 1 step)	4	Power
06	CONT6 signal assignment	0 to 56 (in 1 step)	5	Power
07	CONT7 signal assignment	0 to 56 (in 1 step)	51	Power
08	CONT8 signal assignment	0 to 56 (in 1 step)	0	Power
09	CONT9 signal assignment	0 to 56 (in 1 step)	0	Power
10	CONT10 signal assignment	0 to 56 (in 1 step)	6	Power
11	CONT11 signal assignment	0 to 56 (in 1 step)	7	Power
12	CONT12 signal assignment	0 to 56 (in 1 step)	8	Power
13	CONT13 signal assignment	0 to 56 (in 1 step)	10	Power
14 to 21	Unused	-	0	-
22	Parameter RAM storage 1	0: Not assigned    1 to 99: Basic parameter No.	0	Power
23	Parameter RAM storage 2	0: Not assigned    1 to 99: Basic parameter No.	0	Power
24	Parameter RAM storage 3	0: Not assigned    1 to 99: Basic parameter No.	0	Power
25	Parameter RAM storage 4	0: Not assigned    1 to 99: Basic parameter No.	0	Power
26	Parameter RAM storage 5	0: Not assigned    1 to 99: Basic parameter No.	0	Power
27	Parameter RAM storage 6	0: Not assigned    1 to 99: Basic parameter No.	0	Power
28	Positioning data RAM storage 1	0: Not assigned    1 to 99: Positioning data No.	0	Power
29	Positioning data RAM storage 2	0: Not assigned    1 to 99: Positioning data No.	0	Power
30	Positioning data RAM storage 3	0: Not assigned    1 to 99: Positioning data No.	0	Power
31	OUT1 signal assignment	0 to 75 (in 1 step)	1	Power
32	OUT2 signal assignment	0 to 75 (in 1 step)	2	Power
33	OUT3 signal assignment	0 to 75 (in 1 step)	30	Power
34	OUT4 signal assignment	0 to 75 (in 1 step)	31	Power
35	OUT5 signal assignment	0 to 75 (in 1 step)	0	Power
36	OUT6 signal assignment	0 to 75 (in 1 step)	0	Power
37	OUT7 signal assignment	0 to 75 (in 1 step)	0	Power
38	OUT8 signal assignment	0 to 75 (in 1 step)	0	Power
39	OUT9 signal assignment	0 to 75 (in 1 step)	0	Power
40	OUT10 signal assignment	0 to 75 (in 1 step)	0	Power
41 to 62	Unused	-	0	-
63	Speed command gain	± 0.10 to ± 1.50 times (in 0.01 step)	1.00	Always
64	Speed command offset	-2000 to 2000 (in 1 step)	(Individual)	Always
65	Unused	-	0	-
66	Unused	-	0	-

System parameter for RYS-L type (2/2)

[Basic type]

Para.	Name	Setting range	Initial value	Change
67	Monitor 1 signal assignment	1: Speed command    2: Speed feedback 3: Torque command    4: Position deviation	2	Always
68	Monitor 2 signal assignment	1: Speed command    2: Speed feedback 3: Torque command    4: Position deviation	3	Always
69	Monitor 1 scale	± 2.0 to ± 10.0 [V] (in 0.1 step)	7.0	Always
70	Monitor 1 offset	-50 to 50 (in 1 step)	0	Always
71	Monitor 2 scale	± 2.0 to ± 10.0 [V] (in 0.1 step)	6.0	Always
72	Monitor 2 offset	-50 to 50 (in 1 step)	0	Always
73	Monitor 1, 2 output form	0: Monitor 1 (two-way deflection) / Monitor 2 (two-way deflection) 1: Monitor 1 (one-way deflection) / Monitor 2 (two-way deflection) 2: Monitor 1 (two-way deflection) / Monitor 2 (one-way deflection) 3: Monitor 1 (one-way deflection) / Monitor 2 (one-way deflection)	0	Power
74	Unused	-	0	-
75	Position command form	0: Normal PTP    1: Infinite	0	-
76	+Soft OT detection position	-79999999 to 0 to 79999999 (in 1 step) [x unit q'ty]	79999999	Always
77	-Soft OT detection position	-79999999 to 0 to 79999999 (in 1 step) [x unit q'ty]	-79999999	Always
78	Pulse train input form	0: Command code/pulse    1: Forward/reverse pulse 2: Two 90 ° phase-different signal	1	Power
79	Output pulse count	16 to 16384 [pulse/rev] (in 1 step)	2048	Power
80	Rotational direction changeover	0: Positive direction/forward    1: Positive direction/reverse	0	Power
81	Operation at stoppage	1: Servo lock    2: Brake (P-action)    3: Brake (free-run)	1	Power
82	Brake operation time	0.01 to 9.99 [s] (in 0.01 step)	0.50	Always
83	Brake releasing time	0.01 to 9.99 [s] (in 0.01 step)	0.20	Always
84	Operation at undervoltage	0: Rapidly decelerates to stop    1: Free-run	0	Power
85	Alarm detection at undervoltage	0: No detection    1: Detect	1	Power
86	Resistor thermal relay	0: Electronic thermal relay    1: External thermal relay	0	Power
87	CONT always valid 1	0 to 56 (in 1 step)	0	Power
88	CONT always valid 2	0 to 56 (in 1 step)	0	Power
89	Initial indication	0 to 20 (in 1 step)	0	Power
90 to 93	Unused	-	0	-
94	Parameter rewriting inhibit	0: Rewriting enable    1: Rewriting disable	0	Always
95	Positioning data rewriting inhibit	0: Rewriting enable    1: Rewriting disable	0	Always
96	Station number	1 to 31 (in 1 step)	1	Power
97	Baud rate	0: 9600    1: 19200    2: 38400 [bps]	0	Power
98	Binary/BCD	0: Binary    1: BCD	0	Power
99	INC/ABS system	0: INC (Incremental)    1: ABS (Absolute)	0	Power

System parameter for SX bus type amplifier

Function (input signal) number assigned to system para.1 to 19 (CONT1 to CONT19)

0: Not assigned	32: Positioning cancel
1: Run command [RUN]	34: External fault input
2: Forward command [FWD]	35: Teaching
3: Reverse command [REV]	43: Override valid
4: Auto start [START]	44: Override 1
5: Origin return [ORG]	45: Override 2
6: Origin LS [LS]	46: Override 4
7: +OT [+OT]	47: Override 8
8: -OT [-OT]	48: Interrupt input valid
9: ABS/INC	49: Interrupt input
10: Forced stop [EMG]	50: Deviation clear
11: Alarm reset [RST]	51: Multistep speed X1 [X1]
12: VEL0	52: Multistep speed X2 [X2]
13: VEL1	53: Multistep speed X3 [X3]
14: ACC0	54: Free-run [BX]
16: Position preset	55: Edit permit command
27: Pulse train ratio 1	
28: Pulse train ratio 2	
29: P-action	
30: Torque limit	
31: Temporary stop	

Function (output signal) assigned to system para. 31 to 46 (OUT1 to OUT16)

0: Not assigned	30: Data error
1: Ready [RDY]	31: Address error
2: Positioning end [PSET]	32: Alarm code 0
13: Rewrite end	33: Alarm code 1
14: Brake timing	34: Alarm code 2
15: Dynamic braking	35: Alarm code 3
16: Alarm detection [ALM]	36: Alarm code 4
17: Fixed, passing point 1	38: +OT detection
18: Fixed, passing point 2	39: -OT detection
19: Limiter detection	40: Origin LS detection
20: OT detection	41: Forced stop detection
21: Cycle end [CEND]	60: MD0
22: Origin return end	61: MD1
23: Deviation zero	62: MD2
24: Speed zero [NZERO]	63: MD3
25: Speed arrive [NARV]	64: MD4
26: Torque limit detection	65: MD5
27: Overload early warning	66: MD6
28: CPU ready [CPURDY]	67: MD7
29: Edit permit ON	75: Position preset end

SX bus type  
(SX bus direct  
connection)

System parameter for RYS-L type (1/2)

[SX bus]

Para.	Name	Setting range	Initial value	Change
01	CONT1 signal assignment	0 to 55 (in 1 step)	0	Power
02	CONT2 signal assignment	0 to 55 (in 1 step)	0	Power
03	CONT3 signal assignment	0 to 55 (in 1 step)	0	Power
04	CONT4 signal assignment	0 to 55 (in 1 step)	0	Power
05	CONT5 signal assignment	0 to 55 (in 1 step)	0	Power
06	CONT6 signal assignment	0 to 55 (in 1 step)	1	Power
07	CONT7 signal assignment	0 to 55 (in 1 step)	2	Power
08	CONT8 signal assignment	0 to 55 (in 1 step)	3	Power
09	CONT9 signal assignment	0 to 55 (in 1 step)	11	Power
10	CONT10 signal assignment	0 to 55 (in 1 step)	4	Power
11	CONT11 signal assignment	0 to 55 (in 1 step)	5	Power
12	CONT12 signal assignment	0 to 55 (in 1 step)	51	Power
13	CONT13 signal assignment	0 to 55 (in 1 step)	12	Power
14	CONT14 signal assignment	0 to 55 (in 1 step)	13	Power
15	CONT15 signal assignment	0 to 55 (in 1 step)	9	Power
16	CONT16 signal assignment	0 to 55 (in 1 step)	0	Power
17	CONT17 signal assignment	0 to 55 (in 1 step)	0	Power
18	CONT18 signal assignment	0 to 55 (in 1 step)	0	Power
19	CONT19 signal assignment	0 to 55 (in 1 step)	0	Power
20 to 21	Unused	-	0	-
22	Parameter RAM storage 1	0: Not assigned 1 to 99: Basic parameter No.	0	Power
23	Parameter RAM storage 2	0: Not assigned 1 to 99: Basic parameter No.	0	Power
24	Parameter RAM storage 3	0: Not assigned 1 to 99: Basic parameter No.	0	Power
25	Parameter RAM storage 4	0: Not assigned 1 to 99: Basic parameter No.	0	Power
26	Parameter RAM storage 5	0: Not assigned 1 to 99: Basic parameter No.	0	Power
27	Parameter RAM storage 6	0: Not assigned 1 to 99: Basic parameter No.	0	Power
28	Positioning data RAM storage 1	0: Not assigned 1 to 99: Positioning data No.	0	Power
29	Positioning data RAM storage 2	0: Not assigned 1 to 99: Positioning data No.	0	Power
30	Positioning data RAM storage 3	0: Not assigned 1 to 99: Positioning data No.	0	Power
31	OUT1 signal assignment	0 to 75 (in 1 step)	0	Power
32	OUT2 signal assignment	0 to 75 (in 1 step)	0	Power
33	OUT3 signal assignment	0 to 75 (in 1 step)	1	Power
34	OUT4 signal assignment	0 to 75 (in 1 step)	2	Power
35	OUT5 signal assignment	0 to 75 (in 1 step)	28	Power
36	OUT6 signal assignment	0 to 75 (in 1 step)	16	Power
37	OUT7 signal assignment	0 to 75 (in 1 step)	30	Power
38	OUT8 signal assignment	0 to 75 (in 1 step)	31	Power
39	OUT9 signal assignment	0 to 75 (in 1 step)	0	Power
40	OUT10 signal assignment	0 to 75 (in 1 step)	0	Power
41	OUT11 signal assignment	0 to 75 (in 1 step)	0	Power
42	OUT12 signal assignment	0 to 75 (in 1 step)	0	Power
43	OUT13 signal assignment	0 to 75 (in 1 step)	0	Power
44	OUT14 signal assignment	0 to 75 (in 1 step)	0	Power
45	OUT15 signal assignment	0 to 75 (in 1 step)	0	Power
46	OUT16 signal assignment	0 to 75 (in 1 step)	0	Power

SX bus type  
(SX bus direct  
connection)

System parameter for RYS-L type (2/2)

[SX bus]

Para.	Name	Setting range	Initial value	Change
47 to 66	Unused	-	0	-
67	Monitor 1 signal assignment	1: Speed command    2: Speed feedback 3: Torque command    4: Position deviation	2	Always
68	Monitor 2 signal assignment	1: Speed command    2: Speed feedback 3: Torque command    4: Position deviation	3	Always
69	Monitor 1 scale	± 2.0 to ± 10.0 [V] (in 0.1 step)	7.0	Always
70	Monitor 1 offset	-50 to 50 (in 1 step)	0	Always
71	Monitor 2 scale	± 2.0 to ± 10.0 [V] (in 0.1 step)	6.0	Always
72	Monitor 2 offset	-50 to 50 (in 1 step)	0	Always
73	Monitor 1, 2 output form	0: Monitor 1 (two-way deflection) / Monitor 2 (two-way deflection) 1: Monitor 1 (one-way deflection) / Monitor 2 (two-way deflection) 2: Monitor 1 (two-way deflection) / Monitor 2 (one-way deflection) 3: Monitor 1 (one-way deflection) / Monitor 2 (one-way deflection)	0	Power
74	Unused	-	0	-
75	Position command form	0: Normal PTP    1: Infinite	0	Power
76	+Soft OT detection position	-79999999 to 0 to 79999999 (in 1 step) [x unit q'ty]	79999999	Always
77	-Soft OT detection position	-79999999 to 0 to 79999999 (in 1 step) [x unit q'ty]	-79999999	Always
78	Pulse train input form	0: Command code/pulse    1: Forward/reverse pulse 2: Two 90 ° phase-different signal	1	Power
79	Output pulse count	16 to 16384 [pulse/rev] (in 1 step)	2048	Power
80	Rotational direction changeover	0: Positive direction/forward    1: Positive direction/reverse	0	Power
81	Operation at stoppage	1: Servo lock    2: Brake (P-action)    3: Brake (free-run)	1	Power
82	Brake operation time	0.01 to 9.99 [s] (in 0.01 step)	0.50	Always
83	Brake releasing time	0.01 to 9.99 [s] (in 0.01 step)	0.20	Always
84	Operation at undervoltage	0: Rapidly decelerates to stop    1: Free-run	0	Power
85	Alarm detection at undervoltage	0: No detection    1: Detect	1	Power
86	Resistor thermal relay	0: Electronic thermal relay    1: External thermal relay	0	Power
87	CONT always valid 1	0 to 56 (in 1 step)	0	Power
88	CONT always valid 2	0 to 56 (in 1 step)	0	Power
89	Initial indication	0 to 20 (in 1 step)	6	Power
90 to 93	Unused	-	0	-
94	Parameter rewriting inhibit	0: Rewriting enable    1: Rewriting disable	0	Always
95	Positioning data rewriting inhibit	0: Rewriting enable    1: Rewriting disable	0	Always
96	Station number	1 to 238 (in 1 step)	0	Power
97	Baud rate	0: 9600    1: 19200    2: 38400 [bps]	0	Power
98	Unused	-	0	-
99	INC/ABS system	0: INC (Incremental)    1: ABS (Absolute)	0	Power

System parameter for T-link type amplifier

Function (input signal) number assigned to  
system para.1 to 21, 56 to 59  
(CONT1 to CONT21, CONT22 to CONT25)

Function (output signal) assigned to  
system para. 31 to 51 (OUT1 to OUT21)

0: Not assigned	32: Positioning cancel	0: Not assigned	30: Data error
1: Run command [RUN]	34: External fault input	1: Ready [RDY]	31: Address error
2: Forward command [FWD]	35: Teaching	2: Positioning end [PSET]	32: Alarm code 0
3: Reverse command [REV]	39: Immediate rewrite	13: Rewrite end	33: Alarm code 1
4: Auto start [START]	43: Override valid	14: Brake timing	34: Alarm code 2
5: Origin return [ORG]	44: Override 1	15: Dynamic braking	35: Alarm code 3
6: Origin LS [LS]	45: Override 2	16: Alarm detection [ALM]	36: Alarm code 4
7: +OT [+OT]	46: Override 4	17: Fixed, passing point 1	38: +OT detection
8: -OT [-OT]	47: Override 8	18: Fixed, passing point 2	39: -OT detection
9: ABS/INC	48: Interrupt input valid	19: Limiter detection	40: Origin LS detection
10: Forced stop [EMG]	49: Interrupt input	20: OT detection	41: Forced stop detection
11: Alarm reset [RST]	50: Deviation clear	21: Cycle end [CEND]	60: MD0
12: VELO	51: Multistep speed X1 [X1]	22: Origin return end	61: MD1
13: VEL1	52: Multistep speed X2 [X2]	23: Deviation zero	62: MD2
14: ACC0	53: Multistep speed X3 [X3]	24: Speed zero [NZERO]	63: MD3
16: Position preset	54: Free-run [BX]	25: Speed arrive [NARV]	64: MD4
27: Pulse train ratio 1	55: Edit permit command	26: Torque limit detection	65: MD5
28: Pulse train ratio 2		27: Overload early warning	66: MD6
29: P-action		28: CPU ready [CPURDY]	67: MD7
30: Torque limit		29: Edit permit ON	75: Position preset end
31: Temporary stop			

T-link  
(T-link direct  
connection)

System parameter for RYS-L type (1/2)

[T-link]

Para.	Name	Setting range	Initial value	Change
01	CONT1 signal assignment	0 to 55 (in 1 step)	0	Power
02	CONT2 signal assignment	0 to 55 (in 1 step)	0	Power
03	CONT3 signal assignment	0 to 55 (in 1 step)	0	Power
04	CONT4 signal assignment	0 to 55 (in 1 step)	0	Power
05	CONT5 signal assignment	0 to 55 (in 1 step)	0	Power
06	CONT6 signal assignment	0 to 55 (in 1 step)	0	Power
07	CONT7 signal assignment	0 to 55 (in 1 step)	0	Power
08	CONT8 signal assignment	0 to 55 (in 1 step)	0	Power
09	CONT9 signal assignment	0 to 55 (in 1 step)	1	Power
10	CONT10 signal assignment	0 to 55 (in 1 step)	4	Power
11	CONT11 signal assignment	0 to 55 (in 1 step)	2	Power
12	CONT12 signal assignment	0 to 55 (in 1 step)	3	Power
13	CONT13 signal assignment	0 to 55 (in 1 step)	5	Power
14	CONT14 signal assignment	0 to 55 (in 1 step)	10	Power
15	CONT15 signal assignment	0 to 55 (in 1 step)	11	Power
16	CONT16 signal assignment	0 to 55 (in 1 step)	12	Power
17	CONT17 signal assignment	0 to 55 (in 1 step)	13	Power
18	CONT18 signal assignment	0 to 55 (in 1 step)	7	Power
19	CONT19 signal assignment	0 to 55 (in 1 step)	51	Power
20	CONT20 signal assignment	0 to 55 (in 1 step)	16	Power
21	CONT21 signal assignment	0 to 55 (in 1 step)	0	Power
22	Parameter RAM storage 1	0: Not assigned    1 to 99: Basic parameter No.	0	Power
23	Parameter RAM storage 2	0: Not assigned    1 to 99: Basic parameter No.	0	Power
24	Parameter RAM storage 3	0: Not assigned    1 to 99: Basic parameter No.	0	Power
25	Parameter RAM storage 4	0: Not assigned    1 to 99: Basic parameter No.	0	Power
26	Parameter RAM storage 5	0: Not assigned    1 to 99: Basic parameter No.	0	Power
27	Parameter RAM storage 6	0: Not assigned    1 to 99: Basic parameter No.	0	Power
28	Positioning data RAM storage 1	0: Not assigned    1 to 99: Positioning data No.	0	Power
29	Positioning data RAM storage 2	0: Not assigned    1 to 99: Positioning data No.	0	Power
30	Positioning data RAM storage 3	0: Not assigned    1 to 99: Positioning data No.	0	Power
31	OUT1 signal assignment	0 to 75 (in 1 step)	0	Power
32	OUT2 signal assignment	0 to 75 (in 1 step)	0	Power
33	OUT3 signal assignment	0 to 75 (in 1 step)	0	Power
34	OUT4 signal assignment	0 to 75 (in 1 step)	0	Power
35	OUT5 signal assignment	0 to 75 (in 1 step)	1	Power
36	OUT6 signal assignment	0 to 75 (in 1 step)	2	Power
37	OUT7 signal assignment	0 to 75 (in 1 step)	28	Power
38	OUT8 signal assignment	0 to 75 (in 1 step)	16	Power
39	OUT9 signal assignment	0 to 75 (in 1 step)	31	Power
40	OUT10 signal assignment	0 to 75 (in 1 step)	38	Power
41	OUT11 signal assignment	0 to 75 (in 1 step)	39	Power
42	OUT12 signal assignment	0 to 75 (in 1 step)	40	Power
43	OUT13 signal assignment	0 to 75 (in 1 step)	41	Power
44	OUT14 signal assignment	0 to 75 (in 1 step)	30	Power
45	OUT15 signal assignment	0 to 75 (in 1 step)	0	Power
46	OUT16 signal assignment	0 to 75 (in 1 step)	0	Power

T-link  
(T-link direct  
connection)

System parameter for RYS-L type (2/2)

[T-link]

Para.	Name	Setting range	Initial value	Change
47	OUT17 signal assignment	0 to 75 (in 1 step)	0	Power
48	OUT18 signal assignment	0 to 75 (in 1 step)	0	Power
49	OUT19 signal assignment	0 to 75 (in 1 step)	0	Power
50	OUT20 signal assignment	0 to 75 (in 1 step)	0	Power
51	OUT21 signal assignment	0 to 75 (in 1 step)	0	Power
52 to 55	Unused	-	0	-
56	CONT22 signal assignment	0 to 55 (in 1 step)	0	Power
57	CONT23 signal assignment	0 to 55 (in 1 step)	0	Power
58	CONT24 signal assignment	0 to 55 (in 1 step)	0	Power
59	CONT25 signal assignment	0 to 55 (in 1 step)	0	Power
60 to 67	Unused	-	0	-
68	Monitor 2 signal assignment	1: Speed command    2: Speed feedback 3: Torque command    4: Position deviation	3	Always
69	Unused	-	0	-
70	Unused	-	0	-
71	Monitor 2 scale	± 2.0 to ± 10.0 [V] (in 0.1 step)	6.0	Always
72	Monitor 2 offset	-50 to 50 (in 1 step)	0	Always
73	Monitor 2 output form	0: Monitor 2 (two-way deflection) 1: Monitor 2 (two-way deflection) 2: Monitor 2 (one-way deflection) 3: Monitor 2 (one-way deflection)	0	Power
74	Unused	-	0	-
75	Position command form	0: Normal PTP    1: Infinite	0	Power
76	+Soft OT detection position	-79999999 to 0 to 79999999 (in 1 step) [x unit q'ty]	79999999	Always
77	-Soft OT detection position	-79999999 to 0 to 79999999 (in 1 step) [x unit q'ty]	-79999999	Always
78	Pulse train input form	0: Command code/pulse    1: Forward/reverse pulse 2: Two 90 ° phase-different signal	1	Power
79	Output pulse count	16 to 16384 [pulse/rev] (in 1 step)	2048	Power
80	Rotational direction changeover	0: Positive direction/forward    1: Positive direction/reverse	0	Power
81	Operation at stoppage	1: Servo lock    2: Brake (P-action)    3: Brake (free-run)	1	Power
82	Brake operation time	0.01 to 9.99 [s] (in 0.01 step)	0.50	Always
83	Brake releasing time	0.01 to 9.99 [s] (in 0.01 step)	0.20	Always
84	Operation at undervoltage	0: Rapidly decelerates to stop    1: Free-run	0	Power
85	Alarm detection at undervoltage	0: No detection    1: Detect	1	Power
86	Resistor thermal relay	0: Electronic thermal relay    1: External thermal relay	0	Power
87	CONT always valid 1	0 to 55 (in 1 step)	0	Power
88	CONT always valid 2	0 to 55 (in 1 step)	0	Power
89	Initial indication	0 to 20 (in 1 step)	6	Power
90 to 93	Unused	-	0	-
94	Parameter rewriting inhibit	0: Rewriting enable    1: Rewriting disable	0	Power
95	Positioning data rewriting inhibit	0: Rewriting enable    1: Rewriting disable	0	Always
96	Station number	0 to 99 (in 1 step)	1	Power
97	Baud rate	0: 9600    1: 19200    2: 38400 [bps]	0	Power
98	Binary/BCD	0: Binary    1: BCD	1	Power
99	INC/ABS system	0: INC (Incremental)    1: ABS (Absolute)	0	Power

System parameter for RS485 interface type amplifier

Function (input signal) number assigned to system para.1 to 8 (CONT1 to CONT8)

- |                          |                             |
|--------------------------|-----------------------------|
| 0: Not assigned          | 32: Positioning cancel      |
| 1: Run command [RUN]     | 34: External fault input    |
| 2: Forward command [FWD] | 35: Teaching                |
| 3: Reverse command [REV] | 43: Override valid          |
| 4: Auto start [START]    | 44: Override 1              |
| 5: Origin return [ORG]   | 45: Override 2              |
| 6: Origin LS [LS]        | 46: Override 4              |
| 7: +OT [+OT]             | 47: Override 8              |
| 8: -OT [-OT]             | 48: Interrupt input valid   |
| 9: ABS/INC               | 49: Interrupt input         |
| 10: Forced stop [EMG]    | 50: Deviation clear         |
| 11: Alarm reset [RST]    | 51: Multistep speed X1 [X1] |
| 12: VELD                 | 52: Multistep speed X2 [X2] |
| 13: VEL1                 | 53: Multistep speed X3 [X3] |
| 14: ACC0                 | 54: Free-run [BX]           |
| 16: Position preset      | 55: Edit permit command     |
| 27: Pulse train ratio 1  | 56: Current position output |
| 28: Pulse train ratio 2  |                             |
| 29: P-action             |                             |
| 30: Torque limit         |                             |
| 31: Temporary stop       |                             |

Function (output signal) assigned to system para. 31 to 42 (OUT1 to OUT12)

- |                            |                           |
|----------------------------|---------------------------|
| 0: Not assigned            | 30: Data error            |
| 1: Ready [RDY]             | 31: Address error         |
| 2: Positioning end [PSET]  | 32: Alarm code 0          |
| 13: Rewrite end            | 33: Alarm code 1          |
| 14: Brake timing           | 34: Alarm code 2          |
| 15: Dynamic braking        | 35: Alarm code 3          |
| 16: Alarm detection [ALM]  | 36: Alarm code 4          |
| 17: Fixed, passing point 1 | 38: +OT detection         |
| 18: Fixed, passing point 2 | 39: -OT detection         |
| 19: Limiter detection      | 40: Origin LS detection   |
| 20: OT detection           | 41: Forced stop detection |
| 21: Cycle end [CEND]       | 60: MD0                   |
| 22: Origin return end      | 61: MD1                   |
| 23: Deviation zero         | 62: MD2                   |
| 24: Speed zero [NZERO]     | 63: MD3                   |
| 25: Speed arrive [NARV]    | 64: MD4                   |
| 26: Torque limit detection | 65: MD5                   |
| 27: Overload early warning | 66: MD6                   |
| 28: CPU ready [CPURDY]     | 67: MD7                   |
| 29: Edit permit ON         | 75: Position preset end   |

System parameter for RYS-L type (1/2)

[RS485 interface]

No.	Name	Setting range	Initial value	Change
01	CONT1 signal assignment	0 to 56 (in 1 step)	1	Power
02	CONT2 signal assignment	0 to 56 (in 1 step)	4	Power
03	CONT3 signal assignment	0 to 56 (in 1 step)	6	Power
04	CONT4 signal assignment	0 to 56 (in 1 step)	7	Power
05	CONT5 signal assignment	0 to 56 (in 1 step)	8	Power
06	CONT6 signal assignment	0 to 56 (in 1 step)	10	Power
07	CONT7 signal assignment	0 to 56 (in 1 step)	0	Power
08	CONT8 signal assignment	0 to 56 (in 1 step)	0	Power
9 to 21	Unused	-	0	-
22	Parameter RAM storage 1	0: Not assigned    1 to 99: Basic parameter No.	0	Power
23	Parameter RAM storage 2	0: Not assigned    1 to 99: Basic parameter No.	0	Power
24	Parameter RAM storage 3	0: Not assigned    1 to 99: Basic parameter No.	0	Power
25	Parameter RAM storage 4	0: Not assigned    1 to 99: Basic parameter No.	0	Power
26	Parameter RAM storage 5	0: Not assigned    1 to 99: Basic parameter No.	0	Power
27	Parameter RAM storage 6	0: Not assigned    1 to 99: Basic parameter No.	0	Power
28	Positioning data RAM storage 1	0: Not assigned    1 to 99: Positioning data No.	0	Power
29	Positioning data RAM storage 2	0: Not assigned    1 to 99: Positioning data No.	0	Power
30	Positioning data RAM storage 3	0: Not assigned    1 to 99: Positioning data No.	0	Power
31	OUT1 signal assignment	0 to 75 (in 1 step)	1	Power
32	OUT2 signal assignment	0 to 75 (in 1 step)	2	Power
33	OUT3 signal assignment	0 to 75 (in 1 step)	0	Power
34	OUT4 signal assignment	0 to 75 (in 1 step)	0	Power
35	OUT5 signal assignment	0 to 75 (in 1 step)	16	Power
36	OUT6 signal assignment	0 to 75 (in 1 step)	2	Power
37	OUT7 signal assignment	0 to 75 (in 1 step)	24	Power
38	OUT8 signal assignment	0 to 75 (in 1 step)	36	Power
39	OUT9 signal assignment	0 to 75 (in 1 step)	35	Power
40	OUT10 signal assignment	0 to 75 (in 1 step)	34	Power
41	OUT11 signal assignment	0 to 75 (in 1 step)	33	Power
42	OUT12 signal assignment	0 to 75 (in 1 step)	32	Power

System parameter for RYS-L type (2/2)

[RS485 interface]

No.	Name	Setting range	Initial value	Change
43 to 67	Unused	-	0	-
68	Monitor 2 signal assignment	1: Speed command    2: Speed feedback 3: Torque command    4: Position deviation	3	Always
69	Unused	-	0	-
70	Unused	-	0	-
71	Monitor 2 scale	± 2.0 to ± 10.0 [V] (in 0.1 step)	6.0	Always
72	Monitor 2 offset	-50 to 50 (in 1 step)	0	Always
73	Monitor 2 output form	0: Monitor 2 (two-way deflection) 1: Monitor 2 (two-way deflection) 2: Monitor 2 (one-way deflection) 3: Monitor 2 (one-way deflection)	0	Power
74	Unused	-	0	-
75	Position command form	0: Normal PTP    1: Infinite	0	-
76	+Soft OT detection position	-79999999 to 0 to 79999999 (in 1 step) [x unit q'ty]	79999999	Always
77	-Soft OT detection position	-79999999 to 0 to 79999999 (in 1 step) [x unit q'ty]	-79999999	Always
78	Pulse train input form	0: Command code/pulse    1: Forward/reverse pulse 2: Two 90 ° phase-different signal	1	Power
79	Output pulse count	16 to 16384 [pulse/rev] (in 1 step)	2048	Power
80	Rotational direction changeover	0: Positive direction/forward    1: Positive direction/reverse	0	Power
81	Operation at stoppage	1: Servo lock    2: Brake (P-action)    3: Brake (free-run)	1	Power
82	Brake operation time	0.01 to 9.99 [s] (in 0.01 step)	0.50	Always
83	Brake releasing time	0.01 to 9.99 [s] (in 0.01 step)	0.20	Always
84	Operation at undervoltage	0: Rapidly decelerates to stop    1: Free-run	0	Power
85	Alarm detection at undervoltage	0: No detection    1: Detect	1	Power
86	Resistor thermal relay	0: Electronic thermal relay    1: External thermal relay	0	Power
87	CONT always valid 1	0 to 55 (in 1 step)	0	Power
88	CONT always valid 2	0 to 55 (in 1 step)	0	Power
89	Initial indication	0 to 20 (in 1 step)	6	Power
91	Response time	0: Invalid    0.03 to 1.00 [s] (in 0.01 step)	0	Always
92	Receiving valid time	0.03 to 1.00 [s] (in 0.01 step)	0.50	Always
93	Communication time over	0: Invalid    0.03 to 9.99 [s] (in 0.01 step)	0	Always
94	Parameter rewriting inhibit	0: Rewriting enable    1: Rewriting disable	0	Always
95	Positioning data rewriting inhibit	0: Rewriting enable    1: Rewriting disable	0	Always
96	Station number	1 to 31 (in 1 step)	1	Power
97	Baud rate	0: 9600    1: 19200    2: 38400 [bps]	0	Power
98	Unused	-	0	-
99	INC/ABS system	0: INC (Incremental)    1: ABS (Absolute)	0	Power

## 6.2 Basic parameter

The contents of the basic parameter setting are described in the order of numbers. The settings are common to all amplifiers.

(1) Basic parameter 1 to 7

**Pn001 / PP001 - PP007**

Para.	Name	Setting range	Initial value	Change
01	Manual feed speed 1	0.01 to max. speed [r/min] (in 0.01 step)	100.00	Always
02	Manual feed speed 2	0.01 to max. speed [r/min] (in 0.01 step)	500.00	Always
03	Manual feed speed 3	0.01 to max. speed [r/min] (in 0.01 step)	1000.00	Always
04	Manual feed speed 4	0.01 to max. speed [r/min] (in 0.01 step)	100.00	Always
05	Manual feed speed 5	0.01 to max. speed [r/min] (in 0.01 step)	100.00	Always
06	Manual feed speed 6	0.01 to max. speed [r/min] (in 0.01 step)	100.00	Always
07	Manual feed speed 7	0.01 to max. speed [r/min] (in 0.01 step)	100.00	Always

The rotational speed can be specified at forward command [FWD] (reverse command [REV]) on.

Selecting the on/off combination of X1, X2, and X3 terminal can change the rotational speed.

The rotational speed can be changed even while motor is running. There is no relation between the order of the basic para. and the setting value size.

For the rotational speed when X1, X2, and X3 terminals are all off, see Section 5.3.1.

### Multistep speed selection

[X3]	[X2]	[X1]	Speed
OFF	OFF	OFF	See Section 5.3.1
OFF	OFF	ON	Speed set by basic para. 1
OFF	ON	OFF	Speed set by basic para. 2
OFF	ON	ON	Speed set by basic para. 3
ON	OFF	OFF	Speed set by basic para. 4
ON	OFF	ON	Speed set by basic para. 5
ON	ON	OFF	Speed set by basic para. 6
ON	ON	ON	Speed set by basic para. 7

(2) Basic parameter 8 to 11

**Pn001 / PP008 - PP011**

Para.	Name	Setting range	Initial value	Change
08	Positioning speed 1	0.01 to max. speed [r/min] (in 0.01 step)	10.00	Always
09	Positioning speed 2	0.01 to max. speed [r/min] (in 0.01 step)	50.00	Always
10	Positioning speed 3	0.01 to max. speed [r/min] (in 0.01 step)	100.00	Always
11	Positioning speed 4	0.01 to max. speed [r/min] (in 0.01 step)	500.00	Always

The motor speed at immediate value start can be set. (For RS485 interface type, the command specifies it.)

Selecting the on/off combination of VEL1 and VEL0 at the auto start signal on can change the rotational speed.

(3) Basic parameter 16

**Pn001 / PP016**

Para.	Name	Setting range	Initial value	Change
16	Maximum speed	0.01 to max. speed [r/min] (in 0.01 step)	5000.00	Always

This para. specifies the maximum value of motor speed.

If motor speed will exceed the maximum speed by the override, the motor rotates at the specified value.

The setting of maximum speed is not valid during position control using pulse train input.

(4) Basic parameter 17 to 20

`Pr001` / `PP017` - `PP020`

Para.	Name	Setting range	Initial value	Change
17	Override 1	0 to 150% (in 1 step)	10	Always
18	Override 2	0 to 150% (in 1 step)	20	Always
19	Override 4	0 to 150% (in 1 step)	40	Always
20	Override 8	0 to 150% (in 1 step)	80	Always

Override weighting can be changed.

When the override 8, 4, 2 and 1 are all on, adding all initial values gives 150 (= 80 + 40 + 20 + 10). If the initial value has been changed and resultant sum exceeded 150, the preceding value is retained.

Moving speed [%] by override

Override 8	Override 4	Override 2	Override 1	Moving speed [%]
OFF	OFF	OFF	OFF	0
OFF	OFF	OFF	ON	10
OFF	OFF	ON	OFF	20
OFF	OFF	ON	ON	30
OFF	ON	OFF	OFF	40
OFF	ON	OFF	ON	50
OFF	ON	ON	OFF	60
OFF	ON	ON	ON	70
ON	OFF	OFF	OFF	80
ON	OFF	OFF	ON	90
ON	OFF	ON	OFF	100
ON	OFF	ON	ON	110
ON	ON	OFF	OFF	120
ON	ON	OFF	ON	130
ON	ON	ON	OFF	140
ON	ON	ON	ON	150

\* Where override weighting is at initial value.

The override is valid for all of the rotating speed except for the interrupt input and later at interrupt positioning and pulse train ratio 1, 2.

(5) Basic parameter 21 to 24

`Pn001` / `PP021` - `PP024`

Para.	Name	Setting range	Initial value	Change
21	Acceleration time 1	0.000 to 99.999 [s] (in 0.001 step)	0.100	Always
22	Deceleration time 1	0.000 to 99.999 [s] (in 0.001 step)	0.100	Always
23	Acceleration time 2	0.000 to 99.999 [s] (in 0.001 step)	0.500	Always
24	Deceleration time 2	0.000 to 99.999 [s] (in 0.001 step)	0.500	Always

The motor acceleration/deceleration time can be set.

This function is valid for all of the accel./decel. operation except for pulse train ratio 1, 2.

The time setting is for the speed range of 0 to 2000 [r/min].

Acceleration time 2 and deceleration time 2 are valid while ACC0 signal is on.

The on/off input of ACC0 is always valid and accel. time/decel. time can also be changed over. The ACC0 is a signal allocated to CONT terminal of system parameters.

External selection of acceleration and deceleration time

ACC0 (14)	Acceleration time	Deceleration time
OFF	Basic para. 21	Basic para. 22
ON	Basic para. 23	Basic para. 24

Acceleration time 1 and deceleration 1 can be set separately. For example, only deceleration time can be lengthened. Most suitable deceleration time can be selected depending on the load volume in driving a carrier machine.

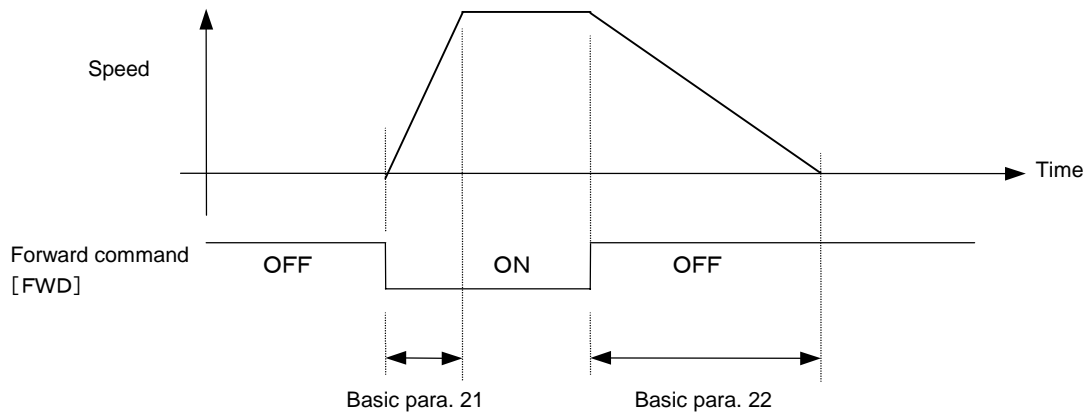

(6) Basic parameter 25

Pr001 / PP025

Para.	Name	Setting range	Initial value	Change
25	Non-linear (S-curve) filter coefficient	0.000 to 1.000 [s] (in 0.001 step)	0.000	Always

The motor can be accelerated/decelerated by drawing an S-curve.

S-shaped curve is drawn at the beginning and at the end of acceleration with the setting time. During deceleration this is the same way.

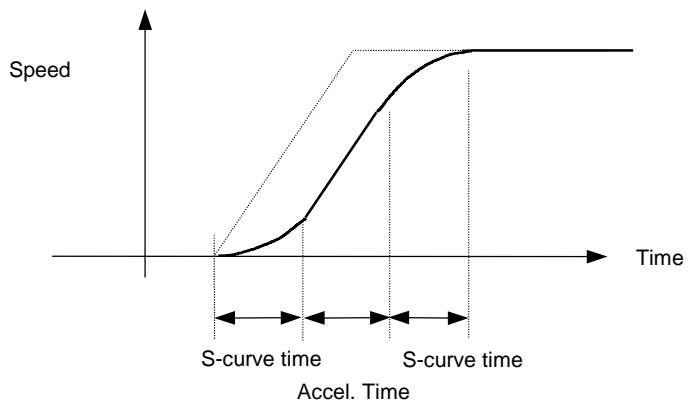

Accel./decel. can be adjusted by using the time constant of the filter coefficient when the pulse train input is given by constant frequency. The motor rotates as much as the pulse train input. Even if the host controller cannot perform linear acceleration, smooth acceleration can be realized.

(7) Basic parameter 31 to 45

Pr001 / PP031 - PP045

Para.	Name	Setting range	Initial value	Change
31	Tuning method	0: Manual 1: Auto (low stiffness) 2: Auto (high stiffness)	1	Always
32	Load inertia ratio	0.0 to 100.0 times (in 0.1 step)	0.0	Always
33	Operation speed response	10 to 1000 [Hz] (in 1 step)	100	Always
34	Speed response at stoppage	10 to 1000 [Hz] (in 1 step)	100	Always
35	Stop detection width	5 to 100 [r/min] (in 1 step)	20	Always
36	Stop judgment time	0.00 to 1.00 [s] (in 0.01 step)	0.00	Always
37	Torque filter time constant	0.00 to 20.00 [ms] (in 0.01 step)	0.30	Always
38	Speed regulator integration time	1 to 1000 [ms] (in 1 step)	20	Always
39	Position regulator gain	1 to 1000 (in 1 step)	50	Always
40	Feed forward gain	0.000 to 1.500 (in 0.001 step)	0.000	Always
41	Speed setting filter	0.0 to 20.0 [ms] (in 0.1 step)	0.0	Always
42	Speed feedback filter	0: OFF 1: ON	0	Always
43	Unused	-	-	-
44	Vibration suppression time constant	10 to 1000 [ms] (in 1 step)	100	Always
45	Vibration suppression gain	0.00 to 1.00 (in 0.01 step)	0.00	Always

The motor response performance can be adjusted according to mechanical equipment system.

The auto-tuning presumes the load moment of inertia of mechanical equipment system and automatically adjusts various control gains of the motor to drive the inertia optimally.

The auto-tuning is valid for general mechanical equipment system, but this may not be valid for the application like vertically moving transfer equipment whose load torque frequently changes.

In this case, select "0 : Manual" for basic para. 31.

In order to activate the auto-tuning, set the following 2 parameters.

Tuning method (basic para. 31)

Operation speed response (basic para. 33)

Selection of tuning method (basic para. 31)

Basic parameter 31

Para.	Name	Setting range	Initial value	Change
31	Tuning method	0: Manual 1: Auto (low stiffness) 2: Auto (high stiffness)	1	Always

Basic parameter 31

Set value	Target machine
1: Auto (low stiffness)	Ball-screw (with speed reducer) Spindle drive (with speed reducer) Rack and pinion Timing belt Conveyor Chain drive Feed roll Table indexing (dividing)
2: Auto (high stiffness)	Ball-screw (direct coupling of motor and screw) Spindle drive (direct coupling)
0: Manual	All of the para. must be set individually.

Set this para. according to mechanical equipment system. In general, the auto (low stiffness) is selected for most of mechanical equipment system.

When the manual is set, automatic regulation regarding the response is not made, and the setting value of each parameter is used.

When the auto (low stiffness) or the auto (high stiffness) is selected, the load inertia is assumed and automatic regulation regarding the response is made according to the basic para. 33 setting.

Operation speed response (basic para. 33)

Basic parameter 33

Para.	Name	Setting range	Initial value	Change
33	Operation speed response	10 to 1000 [Hz] (in 1 step)	100	Always

Use the motor with the initial value of 100 [Hz] in ordinary mechanical equipment system. The higher is the set value, the quicker is the motor's response rate. Mechanical equipment system having direct-coupled ball-screw can have a higher set value (higher response rate as well).

The following 3 basic para. can be automatically adjusted according to the setting value of the operation speed response (basic para. 33).

Basic parameter 37 to 39

Para.	Name	Setting range	Initial value	Change
37	Torque filter time constant	0.00 to 20.00 [ms] (in 0.01 step)	0.00	Always
38	Speed regulator integration time	1 to 1000 [ms] (in 1 step)	20	Always
39	Position regulator gain	1 to 500 (in 1 step)	50	Always

Basic para. 37 to 39 can be adjusted when the auto has been selected in the tuning method (basic para. 31) and when the basic para. 33 setting changed.

Remark : Basic para. 37 to 39 can also be set manually after these have been changed by the amplifier. Usually the amplifier set value is used.

Load inertia ratio (basic para. 32)

Basic parameter 32

Para.	Name	Setting range	Initial value	Change
32	Load inertia ratio	0.0 to 100.0 times (in 0.1 step)	0.0	Always

When the auto (low stiffness) or auto (high stiffness) is selected in tuning method (basic para. 31), the load inertia is assumed and the parameters described before can be automatically adjusted.

The load inertia that the amplifier recognizes does not affect the basic para. 32 setting.

The load inertia can be monitored in the monitor mode [  $\square$   $\square$  14 ] by the keypad panel.

If the load inertia ratio (basic para. 32) setting is 0.0, the assumed load inertia value is applied to the actual servo system. In this case, the assumed load inertia value changes always.

If the setting value is other than 0.0, the control is made assuming that the load inertia ratio has been set. (If the setting value is 3.0, control is made assuming that the load inertia is 3.0 times of the servo motor moment of inertia.

Remark: If the basic para. 31 setting is "0: Manual", the gain of control system is determined as the load inertia of the load inertia ratio (basic para.32)

If the setting is 0.0, the load assumption is not made, and the gain is set assuming that no load is applied.

Speed response at stoppage (basic para. 34)

Basic parameter 34 to 36

Para.	Name	Setting range	Initial value	Change
34	Speed response at stoppage	10 to 1000 [Hz] (in 1 step)	100	Always
35	Stop detection width	5 to 100 [r/min] (in 1 step)	20	Always
36	Stop judgment time	0.0 to 1.00 [s] (in 0.01 step)	0.0	Always

The motor response rate can be changed over between when the motor is rotating and when the motor is stopping. This is valid to reduce the noise when stopping and suppress the resonance with the mechanical equipment system.

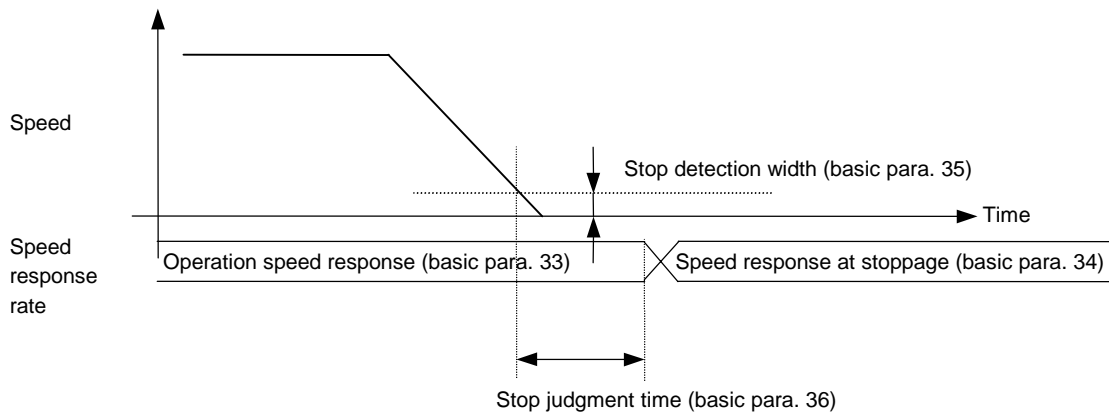

The operation speed response and the speed response at stoppage should be changed after the speed has been lower than the stop detection width (basic para. 35) and the stop judgment time (basic para. 36) has elapsed. This can prevent the motor shaft from starting rotating after the motor has stopped if the setting of speed response at stoppage is low. Set an appropriate time for the stop judgment time as its initial value is 0.0 [s].

Speed feedback filter (basic para. 42)

Basic parameter. 42

Para.	Name	Setting range	Initial value	Change
42	Speed feedback filter	0: OFF 1: ON	0	Always

When you use 16 bit serial encoder in GYC or GYS series, do not change the setting of the speed feedback filter.

Speed setting filter (basic para. 41)

Basic parameter 41

Para.	Name	Setting range	Initial value	Change
41	Speed setting filter	0.0 to 20.0 [ms] (in 0.1 step)	0.0	Always

The speed command [NREF] input can be adjusted by the speed setting filter. This is useful when the motor speed is influenced by the turbulence to the speed command input terminal. The maximum value of the filter time is 20.0 [ms]. This filter is not valid for the amplifier other than the basic type (DI/DO).

Feed forward gain (basic para. 40)

Basic parameter 40

Para.	Name	Setting range	Initial value	Change
40	Feed forward gain	0.000 to 1.500 (in 0.001 step)	0.000	Always

If the feed forward gain is set at 1.0, a smaller deviation (difference between command position and feedback position) can be expected. Set the gain at 1.000 to carry out a synchronous operation between 2 axes using the pulse train input.

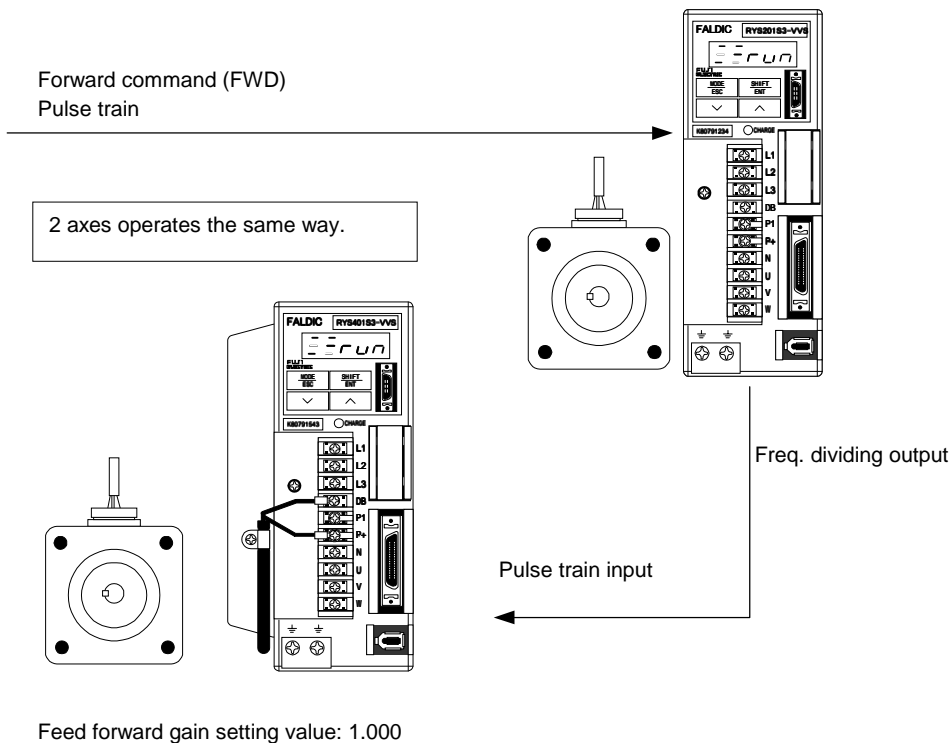

Vibration suppression parameter (basic para. 44, 45)

Basic parameters 44, 45

Para.	Name	Setting range	Initial value	Change
44	Vibration suppression time constant	10 to 1000 [ms] (in 1 step)	100	Always
45	Vibration suppression gain	0.00 to 1.00 (in 0.01 step)	0.00	Always

A periodical vibration in motor rotation speed may occur due to the moment of inertia of mechanical equipment system and the motor's response rate. This parameter is always valid regardless of tuning method (basic para. 31).

The vibration suppression time constant (basic para. 44) sets the vibration cycle of rotational speed. Larger effect can be obtained with the higher setting for the vibration suppression gain.

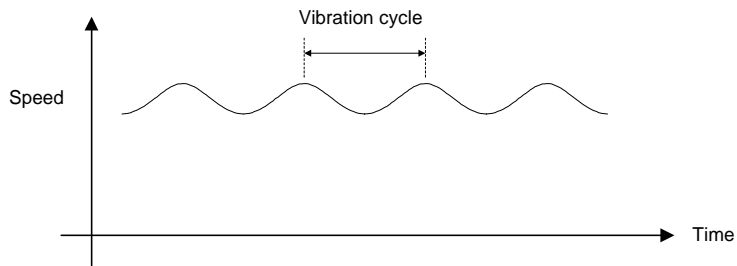

(8) Basic parameter 51

**Pn001 / Pp051**

Para.	Name	Setting range	Initial value	Change
51	Speed matching zone (width)	10 to max. speed [r/min] (in 1 step)	50	Always

The speed arrive signal is turned on when the motor speed is near the reference speed (set by para.) As the initial value is 50 [r/min], the speed arrive signal is on when the motor speed reaches the reference speed  $\pm 50$  [r/min].

When the motor speed does not reach the reference speed due to the max. speed setting (basic. para. 16) or override setting, this signal turns off. When [FWD] or [REV] signal is off, the speed arrive signal does not turn on.

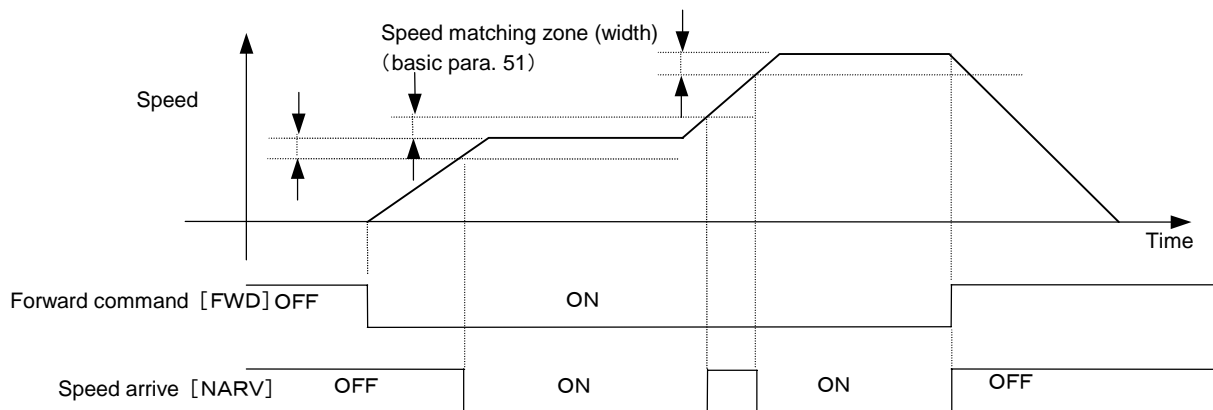

(9) Basic parameter 52

**Pn001 / Pp052**

Para.	Name	Setting range	Initial value	Change
52	Speed zero width	10 to max. speed [r/min] (in 1 step)	20	Always

The output range of the speed zero [NZERO] signal can be set. The minimum unit is 1 [r/min].

(10) Basic parameter 53

**Pn001 / Pp053**

Para.	Name	Setting range	Initial value	Change
53	Deviation zero width	10 to 10000 [pulse] (in 1 step)	200	Always

The range where the deviation zero signal is on can be set. The setting value is the encoder pulse count.

(11) Basic parameter 54

Pr001 / PP054

Para.	Name	Setting range	Initial value	Change
54	Deviation excessive width	10 to 65535 (in 1 step) [x 100 pulse]	10000	Always

Sets the pulse count for alarm detection about deviation excessive. Initial value at factory setting is 10000 and detects the deviation amount with 1000000 pulses. At factory setting, deviation excessive is detected when the difference (deviation) between command position and feedback position becomes approximately 15.2 revolution when converted to motor rotation. The deviation excessive width is set for use with alarm detection.

(12) Basic parameter 55 to 57

Pr001 / PP055 - PP057

Para.	Name	Setting range	Initial value	Change
55	Positioning end output form	0: Level 1: One shot	0	Power
56	Positioning end output time	0.01 to 1.00 [s] (in 0.01 step)	0.10	Always
57	Positioning end judgment time	0.000 to 1.000 [s] (in 0.001 step)	0.050	Always

The output form, output time, and judgment time of positioning end signal [PSET] can be set. For details, see 5.5.2 Positioning end [PSET].

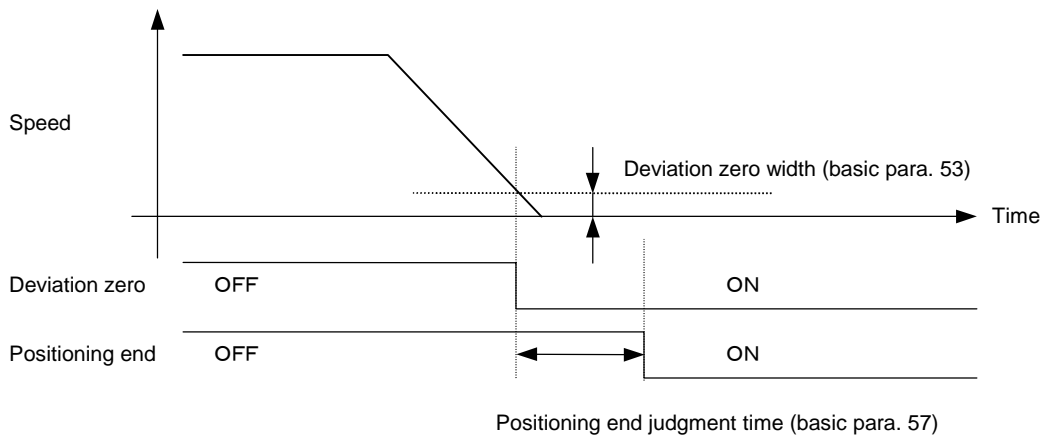

(13) Basic parameter 58

Pn001 / PP058

Para.	Name	Setting range	Initial value	Change
58	Overload early warning level	10 to 100% (in 1 step)	50	Always

\* The trip level of amplifier is 100%.

The output level of overload early warning signal in control output signal can be set.

The overload (alarm detection) level of amplifier is 100%.

For details, see 5.5.6 Overload early warning.

(14) Basic parameter 59

Pn001 / PP059

Para.	Name	Setting range	Initial value	Change
59	Max. torque limit value	0 to max. torque [%] (in 1 step)	300	Always

\* The rated torque is 100%.

The motor output torque can be limited by the para. setting value.

• Where the torque limit (30) is not allocated.

The basic para. 59 is always effective.

• Where the torque limit (30) is allocated.

Data can be changed between the max. torque and the basic para. 59 setting.

(15) Basic parameter 62 to 65

Pn001 / PP062 - PP065

Para.	Name	Setting range	Initial value	Change
62	Fixed, passing point detection	0: Fixed point 1: Passing point OFF/ON 2: Passing point ON/OFF	0	Always
63	Fixed, passing point detection position 1	-79999999 to 0 to 79999999 (in 1 step) [x unit q'ty]	0	Always
64	Fixed, passing point detection position 2	-79999999 to 0 to 79999999 (in 1 step) [x unit q'ty]	0	Always
65	Fixed position detection range	0 to 79999999 (in 1 step) [x unit q'ty]	100	Always

The output form of fixed, passing point 1 and fixed, passing point 2 in control output signal can be set.

The basic para. 65 sets the detection width when "0 : Fixed point" is selected in the basic para. 62.

(16) Basic parameter 66

**Pr001 / PP066**

Para.	Name	Setting range	Initial value	Change
66	Origin detection range	1 to 79999999 (in 1 step) [x unit q'ty]	100	Always

The origin return end signal ON width can be set.

The signal is on within the range of the basic para. 66 setting, based on the position at basic para. 79 at origin return end or at the position preset signal position.

(17) Basic parameter 67

**Pr001 / PP067**

Para.	Name	Setting range	Initial value	Change
67	Position detection valid/invalid	0: Valid after origin return end 1: Always	0	Power

The para. selects whether the position detection functions such as fixed, passing point 1 (fixed, passing point 2) and origin return end signal are always valid, or such functions are valid after origin return end.

The set value 0 means "valid after origin return end".

(18) Basic parameter 71 to 79

**Pr001 / PP071 - PP079**

Para.	Name	Setting range	Initial value	Change
71	Origin return pattern	1: Pattern 1 2: Pattern 2 3: Pattern 3 4: Pattern 4	1	Power
72	Origin return direction	0: Positive direction 1: Negative direction	0	Power
73	Z-phase detection valid/invalid	0: Valid 1: Invalid	0	Power
74	Origin LS logic	0: NO contact 1: NC contact	0	Always
75	Origin return speed	0.01 to max. speed [r/min] (in 0.01 step)	500.00	Always
76	Origin detection creep speed	0.01 to max. speed [r/min] (in 0.01 step)	50.00	Always
77	Origin shift quantity	1 to 2000000 (in 1 step) [x unit q'ty]	1000	Always
78	Origin return reversing quantity	0 to 79999999 (in 1 step) [x unit q'ty]	0	Always
79	Origin return position	-79999999 to 0 to 79999999 (in 1 step) [x unit q'ty]	0	Always

These parameters are related to the origin return action.

For details, see 5.4.1 Origin return.

(19) Basic parameter 80

$Pn001$  /  $PP080$

Para.	Name	Setting range	Initial value	Change
80	Preset position	-79999999 to 0 to 79999999 (in 1 step) [x unit q'ty]	0	Always

This para. sets the position to rewrite with the position preset (16) of control input signal.

(20) Basic parameter 81

$Pn001$  /  $PP081$

Para.	Name	Setting range	Initial value	Change
81	Interrupt move amount	1 to 79999999 (in 1 step) [x unit q'ty]	100000	Always

In interrupt positioning, the move amount from interrupt input to a stop can be set.

The set value is positive (+) only, and the move direction is the rotational direction in interrupt positioning.

(21) Basic parameter 82, 83

$Pn001$  /  $PP082$  -  $PP083$

Para.	Name	Setting range	Initial value	Change
82	Skip feed quantity	1 to 79999999 (in 1 step) [x unit q'ty]	2000	Always
83	Skip feed speed	0.01 to max. speed [r/min] (in 0.01 step)	100.00	Always

These para. set the quantity and speed of the skip feed which is executed in the test running mode by a personal computer loader.

The rotational direction depends on the setting in the test running mode.

(22) Basic parameter 84, 85

$Pn001$  /  $PP084$  -  $PP085$

Para.	Name	Setting range	Initial value	Change
84	+ Limiter detection position	-79999999 to 0 to 79999999 (in 1 step) [x unit q'ty]	79999999	Always
85	- Limiter detection position	-79999999 to 0 to 79999999 (in 1 step) [x unit q'ty]	-79999999	Always

These para. set the detection position of the limiter detection function.

Both set value can be plus (+) or minus (-), the para. 84 set value must be larger than the para. 85 set value.

For the limiter detection, see Section 5.5.9.

(23) Basic parameter 95

`Pr001` / `PP095`

Para.	Name	Setting range	Initial value	Change
86	Backlash correction	0 to 10000 [pulse] (in 1 step)	0	Always

The backlash by mechanical equipment system can be corrected by motor rotational quantity.  
 Everytime the motor rotational direction alters, the motor rotates with the set value added.  
 The current position indication remain unchanged while moving for the backlash correction amount.

(24) Basic parameter 91, 92

`Pr001` / `PP091` - `PP092`

Para.	Name	Setting range	Initial value	Change
91	Command pulse correction	1 to 32767 (in 1 step)	8	Always
92	Command pulse correction	1 to 32767 (in 1 step)	1	Always

Move amount of mechanical equipment system per 1 pulse of command pulse can be converted to unit quantity.  
 \*Unit quantity is any value of 1/1, 1/10, 1/100 or 1/1000.

The factory-set position data value in positioning data does not coincident with the move amount of mechanical equipment system.  
 By setting the command pulse correction and , the position data (ex. 200.00) can be coincident with the move amount (200.00 [mm]) of mechanical equipment system.  
 The move amount of mechanical equipment system per one pulse of the pulse train input is the unit quantity.

The pulse correction value can be obtained by the 16-bit serial encoder (resolution : 65536 [pulse]) and the move amount of mechanical equipment system per one rotation of motor.

$$\frac{\text{(Move amount of mechanical equipment system per one motor rotation)}}{65536 \text{ [pulse/rev]}} \times \frac{\text{Command pulse correction}}{\text{Command pulse correction}} = \text{(Unit quantity)}$$

**【Calculation example】**

Linear positioning of 10 [mm] lead screw to incremental encoder (required unit quantity is 1/100)

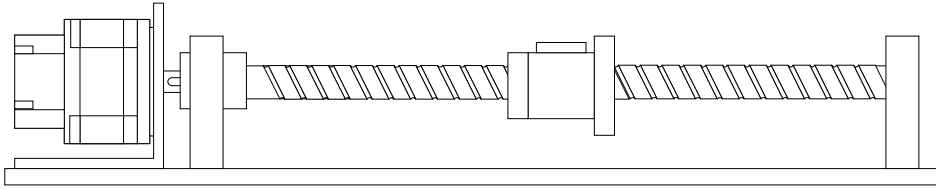

$$\frac{(\text{Move amount of mechanical equipment system per one motor rotation})}{65536 [\text{pulse/rev}]} \times \frac{\text{Command pulse correction}}{\text{Command pulse correction}} = (\text{Unit quantity})$$

$$\frac{10 [\text{mm}]}{65536 [\text{pulse/rev}]} \times \frac{\text{Command pulse correction}}{\text{Command pulse correction}} = 1/100$$

$$\frac{10 [\text{mm}]}{65536 [\text{pulse/rev}]} \times \frac{8192}{125} = 1/100$$

We have obtained the following values :

Command pulse correction : 8192

Command pulse correction : 125

With the above setting, the mechanical equipment system can now be advanced by 0.01 [mm] per one pulse of pulse train input.

If move amount of mechanical equipment system per one rotation includes , it can be replaced with 355/113.

Frequency dividing output has no relation with command pulse correction. The output is according to the system para. 79 setting.

(25) Basic parameter 93, 94

Pr001 / PP093 - PP094

Para.	Name	Setting range	Initial value	Change
93	Pulse train ratio 1	0.01 to 100.00 (in 0.01 step)	1.00	Always
94	Pulse train ratio 2	0.01 to 100.00 (in 0.01 step)	10.00	Always

The setting of the basic para. 91 and 92 can convert the move amount of mechanical equipment system per 1 pulse of command pulse to unit quantity.

The basic para. 93 and 94 can set the scale factors in conversion.

The basic para. 93 and 94 correspond to the pulse train ratio 1 (input signal No. 27) and the pulse train ratio 2 (input signal No.28), respectively.

The condition where the position control becomes valid is as follows:

While the pulse train ratio 1 or pulse ratio 2 is on, and the pulse train input is valid, the manual feed (forward/reverse command), origin return and interrupt positioning do not become valid.

Temporary stop and positioning cancel signal are invalid to the pulse train input.

(26) Basic parameter 95

Pr001 / PP095

Para.	Name	Setting range	Initial value	Change
95	Position data decimal point position	0: 1    1: 0.1    2: 0.01    3: 0.001 4: 0.0001    5: 0.00001	0	Always

The basic para. 95 setting can put a decimal point to the current position indication on the keypad panel.

The position of mechanical equipment system can be monitored by a value with decimal point.

### 6.3 System parameter

The system parameter can set the functional allocation, the station number, etc.

(1) Basic type

(a) System parameter 1 to 13

Pn002 / PP001 – PP013 [Basic type]

Para.	Name	Setting range	Initial value	Change
01	CONT1 signal assignment	0 to 56 (in 1 step)	1	Power
02	CONT2 signal assignment	0 to 56 (in 1 step)	2	Power
03	CONT3 signal assignment	0 to 56 (in 1 step)	3	Power
04	CONT4 signal assignment	0 to 56 (in 1 step)	11	Power
05	CONT5 signal assignment	0 to 56 (in 1 step)	4	Power
06	CONT6 signal assignment	0 to 56 (in 1 step)	5	Power
07	CONT7 signal assignment	0 to 56 (in 1 step)	51	Power
08	CONT8 signal assignment	0 to 56 (in 1 step)	0	Power
09	CONT9 signal assignment	0 to 56 (in 1 step)	0	Power
10	CONT10 signal assignment	0 to 56 (in 1 step)	6	Power
11	CONT11 signal assignment	0 to 56 (in 1 step)	7	Power
12	CONT12 signal assignment	0 to 56 (in 1 step)	8	Power
13	CONT13 signal assignment	0 to 56 (in 1 step)	10	Power

(b) System parameter 31 to 40

Pn002 / PP031 – PP040 [Basic type]

Para.	Name	Setting range	Initial value	Change
31	OUT1 signal assignment	0 to 75 (in 1 step)	1	Power
32	OUT2 signal assignment	0 to 75 (in 1 step)	2	Power
33	OUT3 signal assignment	0 to 75 (in 1 step)	30	Power
34	OUT4 signal assignment	0 to 75 (in 1 step)	31	Power
35	OUT5 signal assignment	0 to 75 (in 1 step)	0	Power
36	OUT6 signal assignment	0 to 75 (in 1 step)	0	Power
37	OUT7 signal assignment	0 to 75 (in 1 step)	0	Power
38	OUT8 signal assignment	0 to 75 (in 1 step)	0	Power
39	OUT9 signal assignment	0 to 75 (in 1 step)	0	Power
40	OUT10 signal assignment	0 to 75 (in 1 step)	0	Power

Function (input signal) number assigned to system para.1 to 13 (CONT1 to CONT13)

0: Not assigned	32: Positioning cancel
1: Run command [RUN]	34: External fault input
2: Forward command [FWD]	35: Teaching
3: Reverse command [REV]	39: Immediate rewrite
4: Auto start [START]	40: Immediate data selection 1
5: Origin return [ORG]	41: Immediate data selection 2
6: Origin LS [LS]	43: Override valid
7: +OT [+OT]	44: Override 1
8: -OT [-OT]	45: Override 2
9: ABS/INC	46: Override 4
10: Forced stop [EMG]	47: Override 8
11: Alarm reset [RST]	48: Interrupt input valid
12: VELD	49: Interrupt input
13: VEL1	50: Deviation clear
14: ACC0	51: Multistep speed X1 [X1]
16: Position preset	52: Multistep speed X2 [X2]
27: Pulse train ratio 1	53: Multistep speed X3 [X3]
28: Pulse train ratio 2	54: Free-run [BX]
29: P-action	55: Edit permit command
30: Torque limit	56: Current position output
31: Temporary stop	

Function (output signal) assigned to system para. 31 to 40 (OUT1 to OUT10)

0: Not assigned	30: Data error
1: Ready [RDY]	31: Address error
2: Positioning end [PSET]	32: Alarm code 0
13: Rewrite end	33: Alarm code 1
14: Brake timing	34: Alarm code 2
15: Dynamic braking	35: Alarm code 3
16: Alarm detection [ALM]	36: Alarm code 4
17: Fixed, passing point 1	38: +OT detection
18: Fixed, passing point 2	39: -OT detection
19: Limiter detection	40: Origin LS detection
20: OT detection	41: Forced stop detection
21: Cycle end [CEND]	60: MD0
22: Origin return end	61: MD1
23: Deviation zero	62: MD2
24: Speed zero [NZERO]	63: MD3
25: Speed arrive [NARV]	64: MD4
26: Torque limit detection	65: MD5
27: Overload early warning	66: MD6
28: CPU ready [CPURDY]	67: MD7
29: Edit permit ON/OFF	75: Position preset end

#### Connector pin layout

The pin layout of the control input / output signal can be changed.

#### CN3 (upper side)

2	P 2 4	1	M 2 4	12	OUT 6	11	OUT 7
4	CONT14	3	CONT15	14	OUT 8	13	OUT 9
6	CONT16	5	CONT17	16	CONT 9	15	OUT 10
8	CONT18	7	CONT19	18	CONT11	17	CONT10
10	CONT20	9	CONT21	20	CONT13	19	CONT12

#### CN1 (lower side)

35	CA	36	*CA	17	NREF	18	M5
33	CB	34	*CB	15	TREF	16	MON 1
31	FA	32	*FA	13	M5	14	MON 2
29	FB	30	*FB	11	P10	12	BAT -
27	FZ	28	*FZ	9	M5	10	BAT +
25	M5	26	OUT 3	7	OUT 4	8	OUT 5
23	CONT 7	24	CONT 8	5	OUT 1	6	OUT 2
21	CONT 1	22	CONT 2	3	CONT 5	4	CONT 6
19	M 2 4	20	P 2 4	1	CONT 3	2	CONT 4

(2) SX bus type

(a) System parameter 1 to 19

Pn002 / PP001 - PP019 [SX bus]

Para.	Name	Setting range	Initial value	Change
01	CONT1 signal assignment	0 to 55 (in 1 step)	0	Power
02	CONT2 signal assignment	0 to 55 (in 1 step)	0	Power
03	CONT3 signal assignment	0 to 55 (in 1 step)	0	Power
04	CONT4 signal assignment	0 to 55 (in 1 step)	0	Power
05	CONT5 signal assignment	0 to 55 (in 1 step)	0	Power
06	CONT6 signal assignment	0 to 55 (in 1 step)	1	Power
07	CONT7 signal assignment	0 to 55 (in 1 step)	2	Power
08	CONT8 signal assignment	0 to 55 (in 1 step)	3	Power
09	CONT9 signal assignment	0 to 55 (in 1 step)	11	Power
10	CONT10 signal assignment	0 to 55 (in 1 step)	4	Power
11	CONT11 signal assignment	0 to 55 (in 1 step)	5	Power
12	CONT12 signal assignment	0 to 55 (in 1 step)	51	Power
13	CONT13 signal assignment	0 to 55 (in 1 step)	12	Power
14	CONT14 signal assignment	0 to 55 (in 1 step)	13	Power
15	CONT15 signal assignment	0 to 55 (in 1 step)	9	Power
16	CONT16 signal assignment	0 to 55 (in 1 step)	0	Power
17	CONT17 signal assignment	0 to 55 (in 1 step)	0	Power
18	CONT18 signal assignment	0 to 55 (in 1 step)	0	Power
19	CONT19 signal assignment	0 to 55 (in 1 step)	0	Power

(b) System parameter 31 to 46

Pn002 / PP031 - PP046 [SX bus]

Para.	Name	Setting range	Initial value	Change
31	OUT1 signal assignment	0 to 75 (in 1 step)	0	Power
32	OUT2 signal assignment	0 to 75 (in 1 step)	0	Power
33	OUT3 signal assignment	0 to 75 (in 1 step)	1	Power
34	OUT4 signal assignment	0 to 75 (in 1 step)	2	Power
35	OUT5 signal assignment	0 to 75 (in 1 step)	28	Power
36	OUT6 signal assignment	0 to 75 (in 1 step)	16	Power
37	OUT7 signal assignment	0 to 75 (in 1 step)	30	Power
38	OUT8 signal assignment	0 to 75 (in 1 step)	31	Power
39	OUT9 signal assignment	0 to 75 (in 1 step)	0	Power
40	OUT10 signal assignment	0 to 75 (in 1 step)	0	Power
41	OUT11 signal assignment	0 to 75 (in 1 step)	0	Power
42	OUT12 signal assignment	0 to 75 (in 1 step)	0	Power
43	OUT13 signal assignment	0 to 75 (in 1 step)	0	Power
44	OUT14 signal assignment	0 to 75 (in 1 step)	0	Power
45	OUT15 signal assignment	0 to 75 (in 1 step)	0	Power
46	OUT16 signal assignment	0 to 75 (in 1 step)	0	Power

The control input/output signal and the signal in IQ area can be changed.

SX bus type  
(SX bus direct  
connection)

Connector pin layout

CN1 (lower side)

26	M 5			13	P 5			12	M 5
24	C B	25	* C B	11	MON 1			10	MON 2
22	C A	23	* C A	9	M 2 4			8	P 2 4
20	F Z	21	* F Z	7	OUT 2			6	OUT 1
18	F B	19	* F B	5	CONT 5			4	CONT 4
16	F A	17	* F A	3	CONT 3			2	CONT 2
14	B A T +	15	B A T -	1	CONT 1				

IQ area

Address	15	14	13	12	11	10	9	8	7	6	5	4	3	2	1	0	
0	Current position, current deviation/basic para., system para., current position data/LS-Z phase pulse (Low order word PC Amplifier)																
1	Current position, current deviation/basic para., system para., current position data/LS-Z phase pulse (High order word PC Amplifier)																
2	Current speed/current speed data (Low order word PC Amplifier)																
3	Current speed/current speed data (High order word PC Amplifier)																
4	Current torque/current timer data (PC Amplifier)																
5	-						Alarm/current status						Current M code				
6	-						CSEL 2	CSEL 1	CSEL 0	Para./current positioning data No.							
7	OUT 3	OUT 4	OUT 5	OUT 6	OUT 7	OUT 8	OUT 9	OUT 10	OUT 11	OUT 12	OUT 13	OUT 14	OUT 15	OUT 16	Rewrite end	Read end	
8	Basic para./system para./position data (Low order word PC Amplifier)																
9	Basic para./system para./position data (High order word PC Amplifier)																
10	Speed command/speed data setting (Low order word PC Amplifier)																
11	Speed command/speed data setting (High order word PC Amplifier)																
12	Timer data setting (PC Amplifier)																
13	-						Status setting						M code setting				
14	-						SEL2	SEL1	SEL0	Para./positioning data No. setting							
15	CONT 6	CONT 7	CONT 8	CONT 9	CONT 10	CONT 11	CONT 12	CONT 13	CONT 14	CONT 15	CONT 16	CONT 17	CONT 18	CONT 19	Rewrite command	Read command	

Function (input signal) number assigned to system para. 1 to 19

Function (output signal) assigned to system para. 31 to 46

- |                          |                             |                            |                           |
|--------------------------|-----------------------------|----------------------------|---------------------------|
| 0: Not assigned          | 32: Positioning cancel      | 0: Not assigned            | 30: Data error            |
| 1: Run command [RUN]     | 34: External fault input    | 1: Ready [RDY]             | 31: Address error         |
| 2: Forward command [FWD] | 35: Teaching                | 2: Positioning end [PSET]  | 32: Alarm code 0          |
| 3: Reverse command [REV] | 43: Override valid          | 13: Rewrite end            | 33: Alarm code 1          |
| 4: Auto start [START]    | 44: Override 1              | 14: Brake timing           | 34: Alarm code 2          |
| 5: Origin return [ORG]   | 45: Override 2              | 15: Dynamic braking        | 35: Alarm code 3          |
| 6: Origin LS [LS]        | 46: Override 4              | 16: Alarm detection [ALM]  | 36: Alarm code 4          |
| 7: +OT                   | 47: Override 8              | 17: Fixed, passing point 1 | 38: +OT detection         |
| 8: -OT                   | 48: Interrupt input valid   | 18: Fixed, passing point 2 | 39: -OT detection         |
| 9: ABS/INC               | 49: Interrupt input         | 19: Limiter detection      | 40: Origin LS detection   |
| 10: Forced stop [EMG]    | 50: Deviation clear         | 20: OT detection           | 41: Forced stop detection |
| 11: Alarm reset [RST]    | 51: Multistep speed X1 [X1] | 21: Cycle end [CEND]       | 60: MD0                   |
| 12: VELO                 | 52: Multistep speed X2 [X2] | 22: Origin return end      | 61: MD1                   |
| 13: VEL1                 | 53: Multistep speed X3 [X3] | 23: Deviation zero         | 62: MD2                   |
| 14: ACC0                 | 54: Free-run [BX]           | 24: Speed zero [NZERO]     | 63: MD3                   |
| 16: Position preset      | 55: Edit permit command     | 25: Speed arrive [NARV]    | 64: MD4                   |
| 27: Pulse train ratio 1  |                             | 26: Torque limit detection | 65: MD5                   |
| 28: Pulse train ratio 2  |                             | 27: Overload early warning | 66: MD6                   |
| 29: P-action             |                             | 28: CPU ready [CPURDY]     | 67: MD7                   |
| 30: Torque limit         |                             | 29: Edit permit ON         | 75: Position preset end   |
| 31: Temporary stop       |                             |                            |                           |

(3) T-link type

(a) System parameter 1 to 21, 56 to 59

T-link  
(T-link direct  
connection)

Pn002 / PP001 - PP021 [T-link type]  
PP056 - PP059

Para.	Name	Setting range	Initial value	Change
01	CONT1 signal assignment	0 to 55 (in 1 step)	0	Power
02	CONT2 signal assignment	0 to 55 (in 1 step)	0	Power
03	CONT3 signal assignment	0 to 55 (in 1 step)	0	Power
04	CONT4 signal assignment	0 to 55 (in 1 step)	0	Power
05	CONT5 signal assignment	0 to 55 (in 1 step)	0	Power
06	CONT6 signal assignment	0 to 55 (in 1 step)	0	Power
07	CONT7 signal assignment	0 to 55 (in 1 step)	0	Power
08	CONT8 signal assignment	0 to 55 (in 1 step)	0	Power
09	CONT9 signal assignment	0 to 55 (in 1 step)	1	Power
10	CONT10 signal assignment	0 to 55 (in 1 step)	4	Power
11	CONT11 signal assignment	0 to 55 (in 1 step)	2	Power
12	CONT12 signal assignment	0 to 55 (in 1 step)	3	Power
13	CONT13 signal assignment	0 to 55 (in 1 step)	5	Power
14	CONT14 signal assignment	0 to 55 (in 1 step)	10	Power
15	CONT15 signal assignment	0 to 55 (in 1 step)	11	Power
16	CONT16 signal assignment	0 to 55 (in 1 step)	12	Power
17	CONT17 signal assignment	0 to 55 (in 1 step)	13	Power
18	CONT18 signal assignment	0 to 55 (in 1 step)	9	Power
19	CONT19 signal assignment	0 to 55 (in 1 step)	51	Power
20	CONT20 signal assignment	0 to 55 (in 1 step)	16	Power
21	CONT21 signal assignment	0 to 55 (in 1 step)	0	Power
56	CONT22 signal assignment	0 to 55 (in 1 step)	0	Power
57	CONT23 signal assignment	0 to 55 (in 1 step)	0	Power
58	CONT24 signal assignment	0 to 55 (in 1 step)	0	Power
59	CONT25 signal assignment	0 to 55 (in 1 step)	0	Power

Function (input signal) number assigned to system para. 1 to 21, 56 to 59

Function (output signal) assigned to system para. 31 to 40

- |                                                                                                                                                                                                                                                                                                                                                                                                                                                                                                                                                                                                                                                                                |                                                                                                                                                                                                                                                                                                                                                                                                                                                                                                                                      |
|--------------------------------------------------------------------------------------------------------------------------------------------------------------------------------------------------------------------------------------------------------------------------------------------------------------------------------------------------------------------------------------------------------------------------------------------------------------------------------------------------------------------------------------------------------------------------------------------------------------------------------------------------------------------------------|--------------------------------------------------------------------------------------------------------------------------------------------------------------------------------------------------------------------------------------------------------------------------------------------------------------------------------------------------------------------------------------------------------------------------------------------------------------------------------------------------------------------------------------|
| <ul style="list-style-type: none"> <li>0: Not assigned</li> <li>1: Run command [RUN]</li> <li>2: Forward command [FWD]</li> <li>3: Reverse command [REV]</li> <li>4: Auto start [START]</li> <li>5: Origin return [ORG]</li> <li>6: Origin LS [LS]</li> <li>7: +OT</li> <li>8: -OT</li> <li>9: ABS/INC</li> <li>10: Forced stop [EMG]</li> <li>11: Alarm reset [RST]</li> <li>12: VELO</li> <li>13: VEL1</li> <li>14: ACC0</li> <li>16: Position preset</li> <li>27: Pulse train ratio 1</li> <li>28: Pulse train ratio 2</li> <li>29: P-action</li> <li>30: Torque limit</li> <li>31: Temporary stop</li> </ul>                                                               | <ul style="list-style-type: none"> <li>32: Positioning cancel</li> <li>34: External fault input</li> <li>35: Teaching</li> <li>43: Override valid</li> <li>44: Override 1</li> <li>45: Override 2</li> <li>46: Override 4</li> <li>47: Override 8</li> <li>48: Interrupt input valid</li> <li>49: Interrupt input</li> <li>50: Deviation clear</li> <li>51: Multistep speed X1 [X1]</li> <li>52: Multistep speed X2 [X2]</li> <li>53: Multistep speed X3 [X3]</li> <li>54: Free-run [BX]</li> <li>55: Edit permit command</li> </ul> |
| <ul style="list-style-type: none"> <li>0: Not assigned</li> <li>1: Ready [RDY]</li> <li>2: Positioning end [PSET]</li> <li>13: Rewrite end</li> <li>14: Brake timing</li> <li>15: Dynamic braking</li> <li>16: Alarm detection [ALM]</li> <li>17: Fixed, passing point 1</li> <li>18: Fixed, passing point 2</li> <li>19: Limiter detection</li> <li>20: OT detection</li> <li>21: Cycle end [CEND]</li> <li>22: Origin return end</li> <li>23: Deviation zero</li> <li>24: Speed zero [NZERO]</li> <li>25: Speed arrive [NARV]</li> <li>26: Torque limit detection</li> <li>27: Overload early warning</li> <li>28: CPU ready [CPURDY]</li> <li>29: Edit permit ON</li> </ul> | <ul style="list-style-type: none"> <li>30: Data error</li> <li>31: Address error</li> <li>32: Alarm code 0</li> <li>33: Alarm code 1</li> <li>34: Alarm code 2</li> <li>35: Alarm code 3</li> <li>36: Alarm code 4</li> <li>38: +OT detection</li> <li>39: -OT detection</li> <li>40: Origin LS detection</li> <li>41: Forced stop detection</li> <li>60: MD0</li> <li>61: MD1</li> <li>62: MD2</li> <li>63: MD3</li> <li>64: MD4</li> <li>65: MD5</li> <li>66: MD6</li> <li>67: MD7</li> <li>75: Position preset end</li> </ul>     |

(b) System parameter 31 to 51

Pn002 / PP031 - PP051 [T-link type]

Para.	Name	Setting range	Initial value	Change
31	OUT1 signal assignment	0 to 75 (in 1 step)	0	Power
32	OUT2 signal assignment	0 to 75 (in 1 step)	0	Power
33	OUT3 signal assignment	0 to 75 (in 1 step)	0	Power
34	OUT4 signal assignment	0 to 75 (in 1 step)	0	Power
35	OUT5 signal assignment	0 to 75 (in 1 step)	1	Power
36	OUT6 signal assignment	0 to 75 (in 1 step)	2	Power
37	OUT7 signal assignment	0 to 75 (in 1 step)	28	Power
38	OUT8 signal assignment	0 to 75 (in 1 step)	16	Power
39	OUT9 signal assignment	0 to 75 (in 1 step)	31	Power
40	OUT10 signal assignment	0 to 75 (in 1 step)	38	Power
41	OUT11 signal assignment	0 to 75 (in 1 step)	39	Power
42	OUT12 signal assignment	0 to 75 (in 1 step)	40	Power
43	OUT13 signal assignment	0 to 75 (in 1 step)	41	Power
44	OUT14 signal assignment	0 to 75 (in 1 step)	30	Power
45	OUT15 signal assignment	0 to 75 (in 1 step)	0	Power
46	OUT16 signal assignment	0 to 75 (in 1 step)	0	Power
47	OUT17 signal assignment	0 to 75 (in 1 step)	0	Power
48	OUT18 signal assignment	0 to 75 (in 1 step)	0	Power
49	OUT19 signal assignment	0 to 75 (in 1 step)	0	Power
50	OUT20 signal assignment	0 to 75 (in 1 step)	0	Power
51	OUT21 signal assignment	0 to 75 (in 1 step)	0	Power

Connector pin layout  
CN1 (lower side)

26	M 5	25	P 5	13	M 5	12	C B
24	MON 2	23	* C B	11	C A	10	F Z
22	* C A	21	B A T +	9	F B	8	F A
20	OUT 4	19	OUT 3	7	OUT 2	6	OUT 1
18	CONT 8	17	CONT 7	5	CONT 4	4	CONT 3
16	CONT 6	15	CONT 5	3	CONT 2	2	CONT 1
14	M 2 4			1	P 2 4		

WB area

Address	0	1	2	3	4	5	6	7	8	9	A	B	C	D	E	F	
+ 0	OUT 5	OUT 6	OUT 7	OUT 8	OUT 9	OUT 10	OUT 11	OUT 12	OUT 13	OUT 14	OUT 15	OUT 16	OUT 17	OUT 18	OUT 19	OUT 20	
+ 1	OUT 21	ALM 4	ALM 3	ALM 2	ALM 1	ALM 0	Rewrite end	Read end	M code								
+ 2	Read data (High order word PC Amplifier)																
+ 3	Read data (Low order word PC Amplifier)																
+ 4	CONT 9	CONT 10	CONT 11	CONT 12	CONT 13	CONT 14	CONT 15	CONT 16	CONT 17	CONT 18	CONT 19	CONT 20	CONT 21	CONT 22	CONT 23	CONT 24	
+ 5	CONT 25	Rewrite/read data selection					Rewrite command	Read command	Command address								
+ 6	Rewrite data (High order word PC Amplifier)																
+ 7	Rewrite data (Low order word PC Amplifier)																

(4) RS485 interface type

(a) System parameter 1 to 8

**Pn002** / **PP001** – **PP008** [RS485 interface]

Para.	Name	Setting range	Initial value	Change
01	CONT1 signal assignment	0 to 56 (in 1 step)	1	Power
02	CONT2 signal assignment	0 to 56 (in 1 step)	4	Power
03	CONT3 signal assignment	0 to 56 (in 1 step)	6	Power
04	CONT4 signal assignment	0 to 56 (in 1 step)	7	Power
05	CONT5 signal assignment	0 to 56 (in 1 step)	8	Power
06	CONT6 signal assignment	0 to 56 (in 1 step)	10	Power
07	CONT7 signal assignment	0 to 56 (in 1 step)	0	Power
08	CONT8 signal assignment	0 to 56 (in 1 step)	0	Power

(b) System parameter 31 to 42

**Pn002** / **PP031** – **PP042** [RS485 interface]

Para.	Name	Setting range	Initial value	Change
31	OUT1 signal assignment	0 to 75 (in 1 step)	1	Power
32	OUT2 signal assignment	0 to 75 (in 1 step)	2	Power
33	OUT3 signal assignment	0 to 75 (in 1 step)	0	Power
34	OUT4 signal assignment	0 to 75 (in 1 step)	0	Power
35	OUT5 signal assignment	0 to 75 (in 1 step)	16	Power
36	OUT6 signal assignment	0 to 75 (in 1 step)	2	Power
37	OUT7 signal assignment	0 to 75 (in 1 step)	24	Power
38	OUT8 signal assignment	0 to 75 (in 1 step)	36	Power
39	OUT9 signal assignment	0 to 75 (in 1 step)	35	Power
40	OUT10 signal assignment	0 to 75 (in 1 step)	34	Power
41	OUT11 signal assignment	0 to 75 (in 1 step)	33	Power
42	OUT12 signal assignment	0 to 75 (in 1 step)	32	Power

\*The signals OUT5 to OUT12 are reflected to the message (ST2).

Function (input signal) number assigned to system para. 1 to 8

- |                          |                             |
|--------------------------|-----------------------------|
| 0: Not assigned          | 32: Positioning cancel      |
| 1: Run command [RUN]     | 34: External fault input    |
| 2: Forward command [FWD] | 35: Teaching                |
| 3: Reverse command [REV] | 44: Override 1              |
| 4: Auto start [START]    | 45: Override 2              |
| 5: Origin return [ORG]   | 46: Override 4              |
| 6: Origin LS [LS]        | 47: Override 8              |
| 7: +OT                   | 48: Interrupt input valid   |
| 8: -OT                   | 49: Interrupt input         |
| 9: ABS/INC               | 50: Deviation clear         |
| 10: Forced stop [EMG]    | 51: Multistep speed X1 [X1] |
| 11: Alarm reset [RST]    | 52: Multistep speed X2 [X2] |
| 12: VEL0                 | 53: Multistep speed X3 [X3] |
| 13: VEL1                 | 54: Free-run [BX]           |
| 14: ACC0                 | 55: Edit permit command     |
| 16: Position preset      | 56: Current position output |
| 27: Pulse train ratio 1  |                             |
| 28: Pulse train ratio 2  |                             |
| 29: P-action             |                             |
| 30: Torque limit         |                             |
| 31: Temporary stop       |                             |

Function (output signal) assigned to system para. 31 to 42

- |                            |                           |
|----------------------------|---------------------------|
| 0: Not assigned            | 30: Data error            |
| 1: Ready [RDY]             | 31: Address error         |
| 2: Positioning end [PSET]  | 32: Alarm code 0          |
| 13: Rewrite end            | 33: Alarm code 1          |
| 14: Brake timing           | 34: Alarm code 2          |
| 15: Dynamic braking        | 35: Alarm code 3          |
| 16: Alarm detection [ALM]  | 36: Alarm code 4          |
| 17: Fixed, passing point 1 | 38: +OT detection         |
| 18: Fixed, passing point 2 | 39: -OT detection         |
| 19: Limiter detection      | 40: Origin LS detection   |
| 20: OT detection           | 41: Forced stop detection |
| 21: Cycle end [CEND]       | 60: MD0                   |
| 22: Origin return end      | 61: MD1                   |
| 23: Deviation zero         | 62: MD2                   |
| 24: Speed zero [NZERO]     | 63: MD3                   |
| 25: Speed arrive [NARV]    | 64: MD4                   |
| 26: Torque limit detection | 65: MD5                   |
| 27: Overload early warning | 66: MD6                   |
| 28: CPU ready [CPURDY]     | 67: MD7                   |
| 29: Edit permit ON         | 75: Position preset end   |

Connector pin layout

CN1 (lower side)

26	M 5	25	P 5	13	M 5	12	C B
24	MON 2	23	* C B	11	C A	10	F Z
22	* C A	21	B A T +	9	F B	8	F A
20	OUT 4	19	OUT 3	7	OUT 2	6	OUT 1
18	CONT 8	17	CONT 7	5	CONT 4	4	CONT 3
16	CONT 6	15	CONT 5	3	CONT 2	2	CONT 1
14	M 2 4			1	P 2 4		

• Read out from amplifier

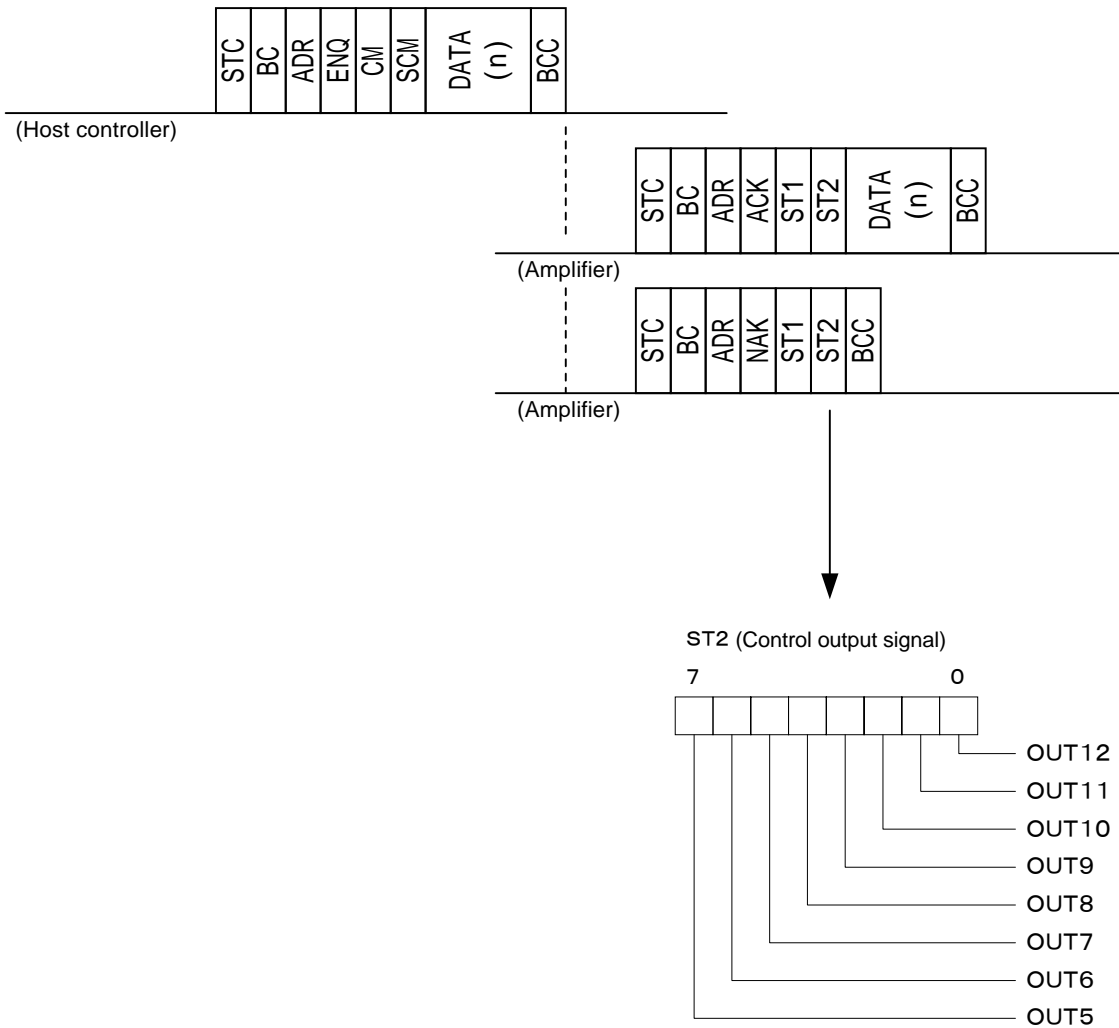

#### (5) Terminal function assignment

Various functions can be assigned to the control input and output terminals.

Set a number corresponding to signal name at desired system parameter, so that the function can be assigned to the terminal.

#### Setting example

Set "1" at the system para. 1 so that the terminal [CONT1] of the control input connector [CN1] functions as the input terminal for the run command [RUN] signal.

#### Duplicated allocation

For the control input terminals, a signal cannot be assigned to more than one terminal simultaneously.

However, only the following signals can be assigned to more than one terminal:

- Forced stop (10)
- Free-run (54)
- External fault input (34)

In case of the forced stop and the external fault input, the motor will stop forcibly if an input terminal is off.

In case of the free-run, the motor will be in free-run status if an input terminal is turned on.

If the signals other than the above have been assigned to more than one terminal, a control signal error [CtE] will be detected when turning on power supply again.

For the control output terminals, a signal can be assigned to more than one terminal simultaneously.

Each terminal goes on or off at the same timing.

#### Interrupt input (49)

Be sure to assign the interrupt input (49) to any one of the terminals [CONT1] to [CONT8].

In case it is assigned to [CONT9] through [CONT13], a control signal error [CtE] will be detected.

For SX bus type, assign it to any one of the terminals [CONT1] to [CONT5].

#### Always valid

The functions can be assigned to the terminals by setting a numerical value at the system para. 1 to 8.

Similarly, the assigned functions can be always valid by setting the function (signal) number at the system para. 87 or 88.

For SX bus type, there are no the always valid function.

Remark : If a number has been assigned to system para. 1 to 8 and system para. 87, 88 simultaneously, a control signal error [CtE] will not be detected.

The assigned signal is always valid.

(6) System parameter 22 to 27 [Basic type, SX bus, T-link, RS485 interface]

**Pn002** / **PP022** - **PP030**

System parameter 22 to 27

Para.	Name	Setting range	Initial value	Change
22	Parameter RAM storage 1	0: Not specified 1 to 99: Basic para. No.	0	Power
23	Parameter RAM storage 2	0: Not specified 1 to 99: Basic para. No.	0	Power
24	Parameter RAM storage 3	0: Not specified 1 to 99: Basic para. No.	0	Power
25	Parameter RAM storage 4	0: Not specified 1 to 99: Basic para. No.	0	Power
26	Parameter RAM storage 5	0: Not specified 1 to 99: Basic para. No.	0	Power
27	Parameter RAM storage 6	0: Not specified 1 to 99: Basic para. No.	0	Power

The contents of basic parameter are stored in the EEPROM (electrically erasable program read only memory) for retaining purpose at power shut down. By specifying RAM, infinite rewriting is enable.

Set the basic para. number to be stored in RAM at the system para. 22 to 27.

The contents of RAM stored basic para. is initialized at power on.

System parameter 28 to 30

Para.	Name	Setting range	Initial value	Change
28	Positioning data RAM storage 1	0: Not specified 1 to 99: Positioning data No.	0	Power
29	Positioning data RAM storage 2	0: Not specified 1 to 99: Positioning data No.	0	Power
30	Positioning data RAM storage 3	0: Not specified 1 to 99: Positioning data No.	0	Power

The contents of positioning data are stored in the EEPROM (electrically erasable program read only memory) for retaining purpose at power shut down. By specifying RAM, infinite rewriting is enable.

Set the positioning data number to be stored in RAM at the system para. 28 to 30.

For the positioning data whose contents have been stored in RAM, the initial value is set when power is turned on.

(7) System parameter 63, 64 [Basic type]

`Pr002` / `PP063` - `PP064`

Para.	Name	Setting range	Initial value	Change
63	Speed command gain	$\pm 0.10$ to $\pm 1.50$ times (in 0.01 step)	1.00	Always
64	Speed command offset	-2000 to 2000 (in 1 step)	(Individual)	Always

The gain or offset of speed command [NREF] terminal can be adjusted.

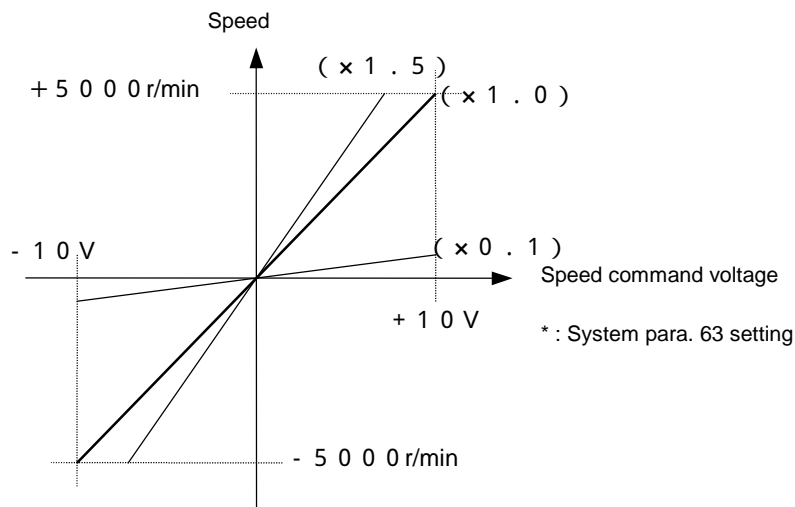

Speed command gain

These gains can be set from  $\pm 0.10$  to  $\pm 1.50$  times in 0.01 step. Specifying the negative sign can invert the rotational direction.

Speed command offset

This can be set from -2000 to 2000 in 1 step. The setting value has no unit. The initial value has been set at factory shipment individually. Automatic offset adjustment is enable in the trial operation mode by the keypad panel (`Fr008`). The value after adjustment will be saved in the system para. 64

(8) System parameter 67 to 73 [Basic type, SX bus, monitor 2 of T-link, RS485 interface]

**Pr002** / **PP067** – **PP073**

Para.	Name	Setting range	Initial value	Change
67	Monitor 1 signal assignment	1: Speed command    2: Speed feedback 3: Torque command    4: Position deviation	2	Always
68	Monitor 2 signal assignment	1: Speed command    2: Speed feedback 3: Torque command    4: Position deviation	3	Always
69	Monitor 1 scale	± 2.0 to ± 10.0 [V] (in 0.1 step)	7.0	Always
70	Monitor 1 offset	-50 to 50 (in 1 step)	0	Always
71	Monitor 2 scale	± 2.0 to ± 10.0 [V] (in 0.1 step)	6.0	Always
72	Monitor 2 offset	-50 to 50 (in 1 step)	0	Always
73	Monitor 1, 2 output form	0: Monitor 1 (two-way deflection) / Monitor 2 (two-way deflection) 1: Monitor 1 (one-way deflection) / Monitor 2 (two-way deflection) 2: Monitor 1 (two-way deflection) / Monitor 2 (one-way deflection) 3: Monitor 1 (one-way deflection) / Monitor 2 (one-way deflection)	0	Power

The output signal form of the monitor 1 [MON1] and monitor 2 [MON2] terminals can be selected.  
Output form is common to position control, speed control and torque control.

#### Monitor 1/ Monitor 2 signal assignment

Sets the output signal from monitor 1 [MON1] and monitor 2 [MON2] terminal.

Setting range	Output signal
1: Speed command	Speed command to the motor recognized by the amplifier
2: Speed feedback	Motor's actual rotational speed
3: Torque command	Torque command value to the motor recognized by the amplifier
4: Position deviation	Difference (deviation) between position command and position feedback

#### Monitor 1/ Monitor 2 scale

Sets the full scale of signal of monitor 1 [MON1] and monitor 2 [MON2] terminals. If the negative sign is specified, the polarity of output voltage can be inverted.

Setting range	Output signal
1: Speed command	Output voltage in response to max. speed.
2: Speed feedback	Output voltage in response to max. speed.
3: Torque command	Output voltage in response to max. torque.
4: Position deviation	Output voltage in response to 1048576 pulses.

#### Monitor 1/ Monitor 2 offset

The offset voltage of monitor 1 [MON1] and monitor 2 [MON2] terminals can be adjusted. The setting range is from -50 to 0 to 50 in 1 step. The setting value has no unit.

#### Monitor 1/ Monitor 2 output form

Two-way deflection or one-way deflection can be selected for the signal assignment, scale and offset of the monitor 1 [MON1] and monitor 2 [MON2] terminals.

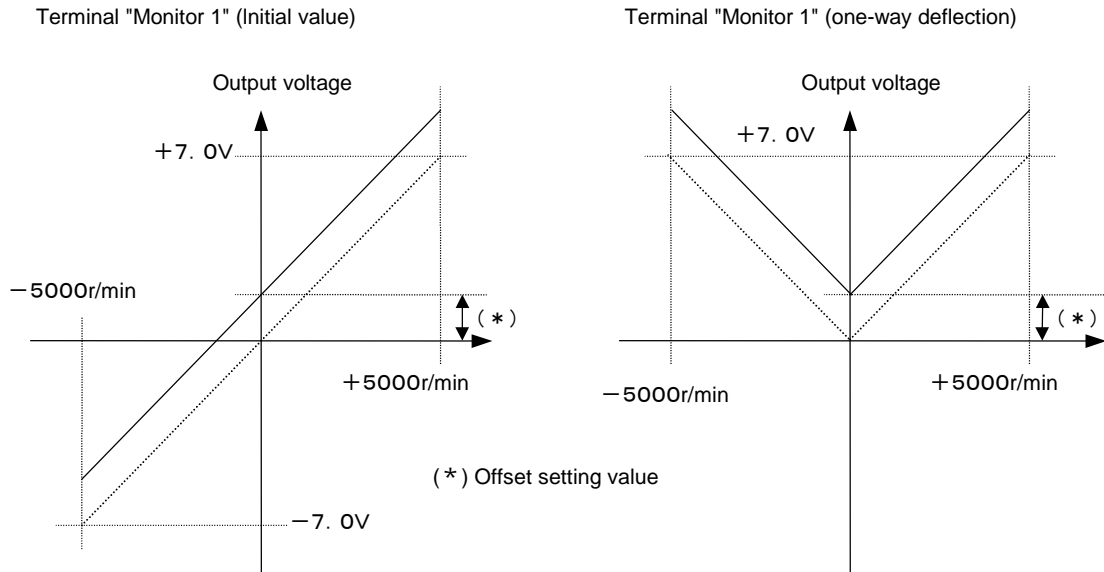

In monitor 1/monitor 2 scale, if the negative sign is specified, the polarity of output voltage can be inverted.

(9) System parameter 75 to 77 [Basic type, SX bus, T-link, RS485 interface]

`Pn002` / `PP075` - `PP077`

Para.	Name	Setting range	Initial value	Change
75	Soft OT valid/invalid	0: Valid 1: Invalid	0	Power
76	+Soft OT detection position	-79999999 to 0 to 79999999 (in 1 step) [x unit q'ty]	79999999	Always
77	-Soft OT detection position	-79999999 to 0 to 79999999 (in 1 step) [x unit q'ty]	-79999999	Always

The soft OT (overtravel preventive signal set by software) can be set.

Different from the +OT, -OT of the control input signal, the soft OT function stops the motor forcibly when the motor current position is beyond the setting value. When the motor has stopped, OT detection (20) of the control output signal is turned on.

The OT detection (20) is turned off when the motor current position is beyond the soft OT range by the pulse train input opposite direction to the detection direction or manual feed. The soft OT detection is not an alarm (protective function activation). The soft OT can be valid after origin return with basic para. 67.

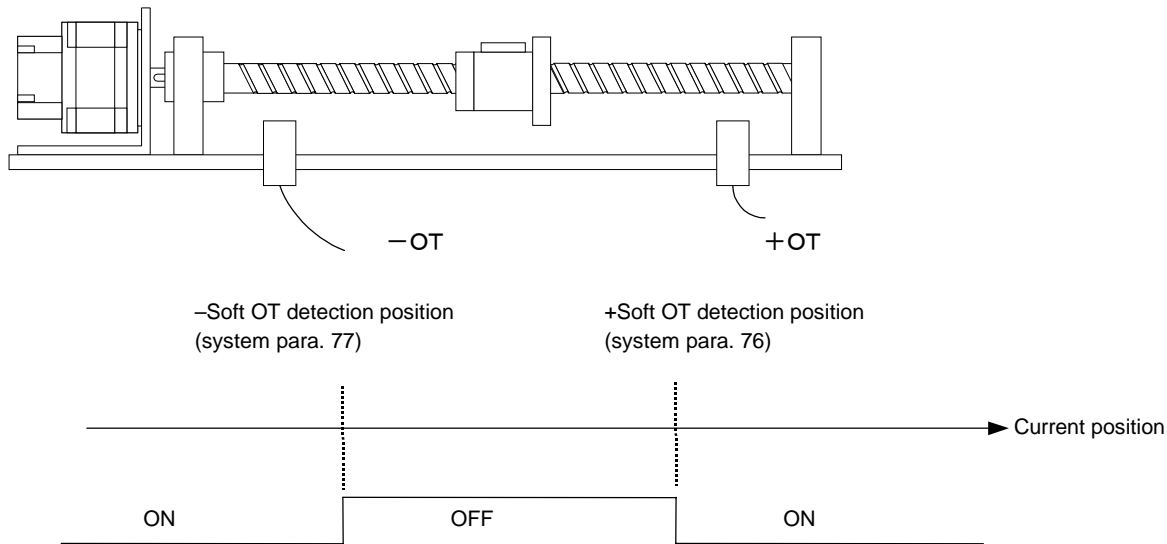

Soft OT cannot be used for OT detection invert operation in origin return pattern 2, 3 or 4.

(10) System parameter 78 [Basic type, SX bus, T-link, RS485 interface]

Pr002 / Pp078

Para.	Name	Setting range	Initial value	Change
78	Pulse train input form	0 : Command code, command pulse 1 : Forward pulse, reverse pulse 2 : Two 90° phase-different signal	1	Power

The pulse form of pulse train input terminal can be selected.

The pulse form of pulse train input terminal [CA], [\*CA], [CB], [\*CB] can be selected. The maximum input frequency is 500 [kHz].

Command code, command pulse (system para. 78 setting : 0)

The command pulse indicates rotational quantity and the command code indicates rotational direction.

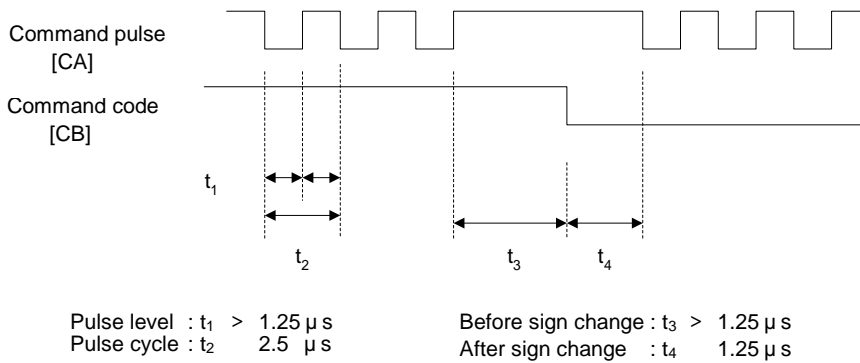

Forward pulse, reverse pulse (system para. 78 setting : 1)

Forward pulse indicates forward direction, reverse pulse indicates the reverse direction.

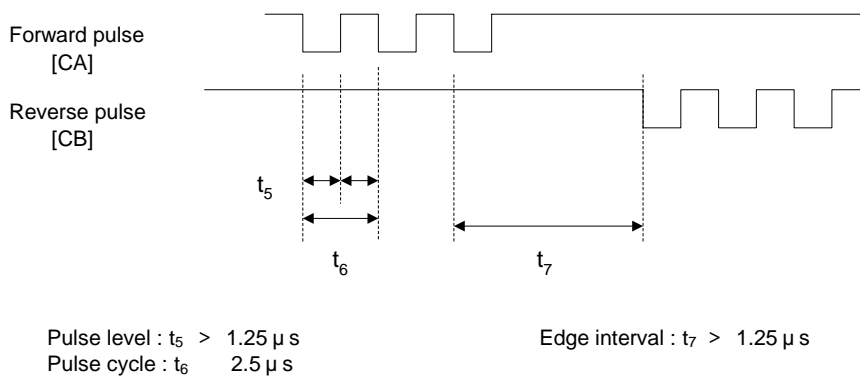

Two 90° phase-different signal (system para. 78 setting : 2)

A-phase and B-phase signal indicate rotational direction and rotational quantity, respectively. Each edge of A-phase and B-phase signals corresponds to one pulse.

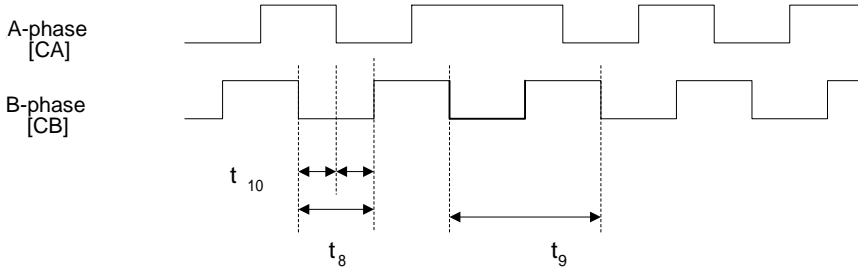

Pulse width :  $t_8 > 1.25 \mu s$   
 Pulse cycle :  $t_9 = 2.5 \mu s$

Edge interval :  $t_{10} > 1.25 \mu s$

(11) System parameter 79 [Basic type, SX bus (line driver output), T-link, RS485 interface (open collector output)]

`Pn002` / `PP079`

Para.	Name	Setting range	Initial value	Change
79	Output pulse count	16 to 16384 [pulse/rev] (in 1 step)	2048	Power

The pulse count in proportion to motor rotational quantity will be output.

The output pulse count can be set for the freq. dividing output terminals [FA], [\*FA], [FB], [\*FB], [FZ], and [\*FZ].

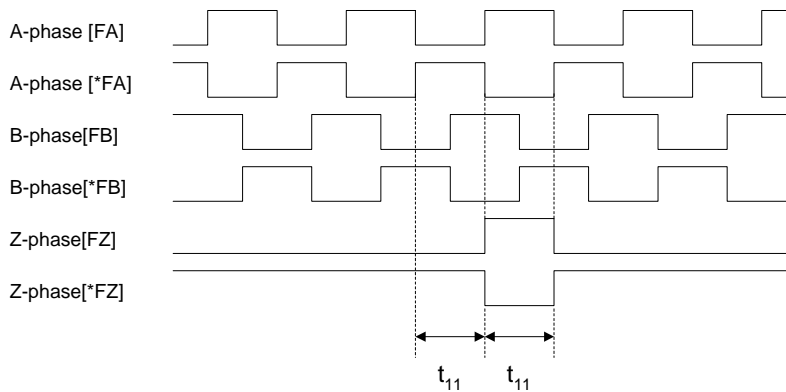

Pulse width :  $t_{11} = 1 \mu s$  (equivalent to 500 [kHz])

A-phase and B-phase signals are 50% duty.

The output pulse counts of A-phase and B-phase signal are determined by system para. 79 setting.

Z-phase signal is output one pulse per revolution. The pulse width depends on the A-phase output pulse count.

A-phase signal and Z-phase signal are synchronized. Recommended output frequency is approx. 500 [kHz]. The output frequency is not restricted by the amplifier.

The position of the motor output shaft has no relation with Z-phase.

The system para. 79 sets the freq. dividing output pulse count per one rotation of motor. The output form is two 90° phase-different signal. When the motor rotates forward, a B-phase advanced pulse is output. This does not depend on the rotational direction changeover setting (system para. 80)

Two 90° phase-different signal is output based on the level at the time of power on.

Max. output frequency depends on the performance of IC (differential driver: AM26LS31 or equivalent) for output terminal.

(12) System parameter 80 [Basic type, SX bus, T-link, RS485 interface]

`Pn002` / `PP080`

Para.	Name	Setting range	Initial value	Change
80	Rotational direction changeover	0 : Positive direction/forward 1 : Positive direction/reverse	0	Power

This para. makes the motor rotational direction match the machine moving direction.

#### Speed command voltage [NREF] (Multistep speed)

The positive direction means the rotational direction when a positive (+) voltage is applied to speed command voltage terminal [NREF] (multistep speed), and forward command [FWD] is given. The motor output shaft rotates forward.

The voltage input of -10 to 0 to +10 [V] can be applied.

#### Pulse train input

The positive direction means the rotational direction when a forward pulse or command code at H level, or a pulse train of two 90° phase-different (B-phase advance) signal is applied. The motor output shaft rotates forward.

#### Forward rotation, reverse rotation

Forward rotation is counterclockwise (CCW) rotation when viewed from a point facing the drive-end of motor. Clockwise rotation is reverse rotation.

#### Resolution of speed command [NREF]

The resolution is 14 bit at full scale. When a speed reference voltage of 5000 [r/min] / 10 [V] is given,  $(-5000 \text{ to } +5000) \text{ [r/min]} / 2^{14} = 0.6 \text{ [r/min]}$  is obtained.

(13) System parameter 81 [Basic type, SX bus, T-link, RS485 interface]

`Pn002` / `PP081`

The status when the motor is stopping can be selected.

Para.	Name	Setting range	Initial value	Change
81	Operation at stopping	0 : Speed zero 1 : Servo lock 2 : Brake (P-action) 3 : Brake (free-run)	1	Power

#### Servo lock

The motor can be stopped retaining the current position (current position of motor's encoder).

#### External brake (P-action)

The motor can be stopped by the motor's brake, by using the brake timing outputted from amplifier. The motor output shaft is mechanically locked and the control system gain on the amplifier side is lowered.

#### External brake (free-run)

The motor can be stopped by the motor's brake, by using the brake timing outputted from amplifier. Noise or vibration will not be generated because the no motor control is made.

For details, see 5.7.10. Brake timing.

(14) System parameter 82, 83 [Basic type, SX bus, T-link, RS485 interface]

`Pn002` / `PP082` - `PP083`

Para.	Name	Setting range	Initial value	Change
82	Brake operation time	0.01 to 9.99 [s] (in 0.01 steps)	0.50	Always
83	Brake releasing time	0.01 to 9.99 [s] (in 0.01 steps)	0.20	Always

System para. 82 and 83 are the time settings of brake timing output.

If the external brake is used, setting change of system para. 81 is needed.

Brake operation time : Time period from when the motor shaft has been stopped, to when the P-action signal is on.

Brake releasing time : Time period from when manual forward or origin return command is on, to when the motor begins running.

(15) System parameter 84, 85 [Basic type, SX bus, T-link, RS485 interface]

**Pn002** / **PP084** – **PP085**

Selects the operation when undervoltage at main circuit input is detected.

Para.	Name	Setting range	Initial value	Change
84	Operation at undervoltage	0: Rapid deceleration to a stop 1: Free-run	0	Power
85	Alarm detection at undervoltage	0: No detection 1: Detects	1	Power

Operation at undervoltage (system para. 84)

Specifies the motor operation when undervoltage has been detected while the run command [RUN] is on.

Setting range	Operation
0: Rapid decel. to a stop	The motor rapidly decelerates to a stop (within amplifier's highest capacity).
1: Free-run	The motor decelerates (or accelerates) with free-run condition according to the load torque.

Alarm detection at undervoltage (system para. 85)

Specifies the alarm detection operation when undervoltage has been detected while the run command [RUN] is on.

Setting range	Operation
0: No detection	Alarm is not detected.
1: Detects	Undervoltage alarm is detected.

If "0" has been set, the motor stops according to the preset operation to be made at undervoltage, and alarm detection will not be output.

Remark: If the power voltage decrease (undervoltage) due to momentary power failure is detected, the motor decelerates by system para. 84 setting. Due to regenerative power generated by the motor during deceleration, voltage level may exceed undervoltage level. In this case, the motor starts deceleration at the undervoltage level. After that, the motor will accelerate again after alarm detection of undervoltage is released.

(16) System parameter 86 [Basic type, SX bus, T-link, RS485 interface]

**Pn002** / **PP086**

Connects the NTC thermistor of braking resistor to the control input terminal to protect the resistor.

Para.	Name	Setting	Initial value	Change
86	Braking resistor thermal overload relay	0: Electronic thermal relay 1: External thermal relay	0	Power

Setting	Overheat detection of braking resistor
0: Electronic thermal relay	Calculates the regenerated power by amplifier to protect the resistor.
1: External thermal relay	Directly detects resistor overheat using NTC thermistor built-in the resistor.

To use external thermal relay, assign the external fault input (34) at the control allocation terminal, connect NTC thermistor for the external resistor.

Protective function by electronic thermal relay built-in the amplifier will be disabled.

(17) System parameter 87, 88 [Basic type, SX-bus, T-link, RS485 interface]

**Pr002** / **PP087** - **PP088**

Arbitrary signals among the control input signals can be always valid.

Para.	Name	Setting range	Initial value	Change
87	CONT always valid 1	0 to 56 (in 1 step)	0	Power
88	CONT always valid 2	0 to 56 (in 1 step)	0	Power

The assignable signals are as follows:

- 1 : Run command [RUN]                      The run command becomes always valid.
- 14 : ACC0                                      Only accel. time 2 and decel. time 2 become always valid.
- 27 : Pulse train ratio 1                      Pulse train ratio 1 or 2 becomes always valid. Do not assign these two signals 1 and 2 at system para. 87 and 88 at the same time.
- 28 : Pulse train ratio 2
- 29 : P-action                                  P-action is always valid. Assignment is not necessary.
- 30 : Torque limit                              Torque limit value becomes always valid. Unless assigned, maximum torque limit value (basic para. 59) setting is valid.
- 43 : Override valid                            Override becomes always valid.
- 44 to 47 : Overeride 1, 2, 4, 8              Only specifically determined magnification becomes valid.
- 48 : Interrupt input valid                    Interrupt input becomes always valid.
- 51 to 53 : [X1], [X2], [x3]                Only specifically determined multistep speed becomes valid.

Remarks: The signals that have been assigned to system para. 87 or 88 are always valid.  
 The only two signals can be always valid.  
 Such on/off timing signals as the current position output (56) cannot be assigned.  
 For SX bus type, system para. 87 and 88 are invalid.

(18) System parameter 89 [Basic type, SX bus, T-link, RS485 interface]

Pn002 / PP089

(a) Basic type







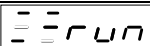
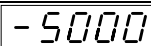
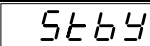

Para.	Name	Setting range	Initial value	Change
89	Initial indication	0 to 20 (in 1 step)	0	Power

(b) SX bus, T-link, RS485 interface

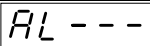
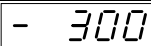
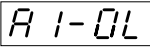
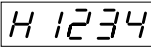
Para.	Name	Setting range	Initial value	Change
89	Initial indication	0 to 20 (in 1 step)	6	Power

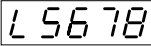
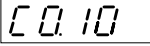
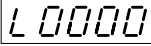
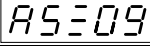
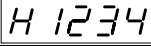
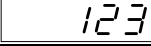
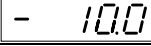
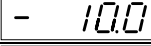
The contents of indication on the keypad panel at power on can be changed.

For the link system such as the SX bus type and T-link, the initial value is 6.

Setting	Indication	Setting	Indication
0	 Sequence	7	 Feedback speed
1	 Sub-mode	8	 Command speed
2	 Alarm detection	9	 Actual torque
3	 Alarm history	10	 Feedback position
4	 Amplifier setting	11	 Command position
5	 Motor setting	12	 Deviation amount
6	 Station No. indication	13	 Cumulated pulse
		14	 Peak torque
		15	 Input voltage 1
		16	 Input voltage 2
		17	 LS-Z pulse
		18	 Input signal
		19	 Output signal
		20	 Load inertia ratio

(19) System parameter 22 to 27 [RS485 interface]

**Pn002** / **PP091** – **PP093**

Para.	Name	Setting range	Initial value	Change
91	Response time	0 : Invalid 0.03 to 1.00 [s] (in 0.01 step)	0	Always
92	Receiving valid time	0.03 to 1.00 [s] (in 0.01 step)	0.50	Always
93	Communication time over	0 : Invalid 0.03 to 9.99 [s] (in 0.01 step)	0	Always

Response time (system para. 91)

The response time for the message to be returned from amplifier can be fixed.

Receiving valid time (system para. 92)

This para. sets the time to receive the message from the top (STC) to the end (BCC). Unless the BCC is received within the set receiving valid time, the message is discarded.

Communication time over (system para. 93)

At factory shipment, the function of communication time over is valid. For details, see 5.10 Serial communication.

(20) System parameter 94, 95 [Basic type, SX bus, T-link, RS485 interface]

**Pn002** / **PP094** – **PP095**

Para.	Name	Setting range	Initial value	Change
94	Parameter rewriting inhibit	0: Rewriting enable 1: Rewriting disable	0	Always
95	Positioning data rewriting inhibit	0: Rewriting enable 1: Rewriting disable	0	Always

Parameter rewriting and positioning data rewriting on the keypad panel can be prohibited.

Even if "1 : Rewriting disable" is selected for the system para. 94, only the system para. 94 is rewritable.

Remark : Rewrite operation can be restricted by the control input signal. See 5.5.2 Edit permit command.

(21) System parameter 96 [Basic type, SX bus, T-link, RS485 interface]

Pn002 / PP096

(a) Basic type, RS485 interface

Para.	Name	Setting range	Initial value	Change
96	Station number	1 to 31 (in 1 step)	1	Power

(b) SX bus

Para.	Name	Setting range	Initial value	Change
96	Station number	1 to 238 (in 1 step)	0	Power

(c) T-link

Para.	Name	Setting range	Initial value	Change
96	Station number	1 to 99 (in 1 step)	0	Power

Sets the station number about communication.

Specifies the amplifier station number at 1 through 31 in decimal.  
If the station number is hexadecimal, see the following conversion table.

Station No. setting (decimal)	Station No. setting (hexadecimal)	Station No. setting (decimal)	Station No. setting (hexadecimal)	Station No. setting (decimal)	Station No. setting (hexadecimal)
1	01H	11	0BH	21	15H
2	02H	12	0CH	22	16H
3	03H	13	0DH	23	17H
4	04H	14	0EH	24	18H
5	05H	15	0FH	25	19H
6	06H	16	10H	26	1AH
7	07H	17	11H	27	1BH
8	08H	18	12H	28	1CH
9	09H	19	13H	29	1DH
10	0AH	20	14H	30	1EH
				31	1FH

If a fail-soft operation is required for SX bus type, specify the desired station number.  
Use the initial value "0" as it is when the station number will be used in the system definition of D300win.

(22) System parameter 97 [Basic type, SX bus, T-link, RS485 interface]

Pn002 / PP097

Para.	Name	Setting range	Initial value	Change
98	Baud rate	0: 9600 1: 19200 2: 38400 [bps]	0	Power

Specifies the RS485 interface baud rate. RYS S3 - \* RS type amplifier has RS485 interface.  
(The \* is replaced by V, L, or R.)  
This baud rate is different from that of the exclusive loader of PC loader.

(23) System parameter 98 [Basic type, T-link]

Pn002 / PP098

Para.	Name	Setting range	Initial value	Change
98	Binary/BCD	0: Binary 1: BCD	0 [Basic type] 1 [T-link]	Power

The code of values handled by the amplifier can be selected.  
 SX-bus type and RS485 interface type amplifiers handle binary code only.  
 The initial value of T-link type amplifier is 1 (BCD).

(24) System parameter 99 [Basic type, SX bus, T-link, RS485 interface]

Pn002 / PP099

Para.	Name	Setting range	Initial value	Change
99	INC/ABC system	0: INC (Incremental) 1: ABS (Absolute)	0	Power

Setting	Current position backup
0: INC (Incremental)	Current position will be deleted if power is shut down. Motor rotational quantity is not limited.
1: ABS (Absolute)	Current position will be recovered if power supply recovers. Motor rotational quantity is limited.

Incremental or absolute system can be selected.

#### Pulse encoder

A 16-bit serial encoder built-in the motor is an INC/ABS common-use encoder.  
An ABS system can be established if a battery is installed in the amplifier.  
 The encoder can output a freq. dividing output pulse of 16 to 16384 [pulse/rev].  
 The multiple rotation count is -32767 to 32767 in an ABS system.

#### Alarm detection in ABS system

The alarms against absolute data overflow (AF) and absolute data lost (AL) will be detected only in the ABS system. These alarms will be reset by the position preset.

#### Current position backup

When power failure occurs, the absolute data of encoder can be backed up by the battery built-in the amplifier. The backup time is approx. one hour after the motor encoder cable is disconnected from the amplifier.

Backup time by encoder alone (Super capacitor)	Approx. one hour
---------------------------------------------------	------------------

Some backup methods are available.

1) Battery built-in amplifier (type : WBS-S)

This is a lithium (primary) battery built in the amplifier and cannot be recharged.

The lifetime is approx. 7 years on condition that it is turned on for 8 hours per day (it backups 16 hours)

Lifetime of optional battery (16 hour backup after 8 hour power on per day)	Approx. 7 years
--------------------------------------------------------------------------------	-----------------

2) External battery

The connector 1 (CN1) for control input/output is equipped with the input terminals [+BAT], [-BAT] for backup power. Connect 3.6 [V] power to these terminals.

Do not install the backup battery into the amplifier itself if you connect the backup power.

As long as the backup power exists, the amplifier is backed up.

3) Power supply for control circuit

If a UPS is prepared as a peripheral device, connect its power to the control power input terminal so that power can be supplied to the control circuit only (backup is available at the same time).

## 7. KEYPAD PANEL

### 7.1 Display

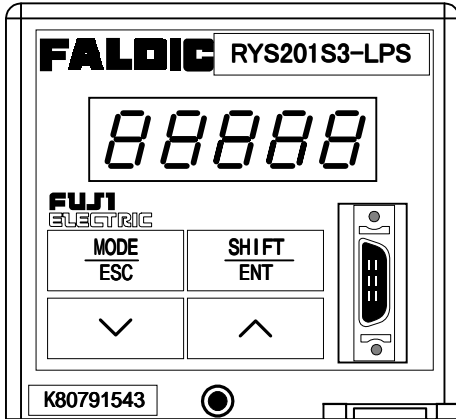

The amplifier is provided with a keypad panel. It has a display section of five 7-segment LED digits and 4 operation keys. Figures and letters are displayed on the display section.

Remark: The keypad panel cannot be removed.

#### (1) Mode

The keypad panel operation can be classified into 5 modes.

- Sequence mode ..... Indicates the amplifier status.
- Monitor mode ..... Monitors the motor speed and the input/output signal status.
- Parameter edit mode ..... Edits the parameter setting.
- Positioning data edit mode ..... Edits the positioning data.
- Test running mode ..... Operates the motor with the keypad operation.

#### List of 7-segment indication

0	1	2	3	4	5	6	7	8	9	-
A	b	C	d	E	F	G	H	I	J	L
n	O	o	P	r	S	t	U, V	u, v	y	

**(2) Operation key**



Change the mode (MODE).  
Returns from the mode (ESC).





Moves the cursor to the right at data change (SHIFT).  
Stores the mode and figure (ENT). Press more than 1 [s] to store the data.



Selects the sub-mode.  
Decreases the figure (-1).  
When a figure decreases from 0 to 9, the figure on the one higher digit decreases by one.

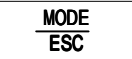

Selects the sub-mode.  
Increases the figure (+1).  
When a figure increases from 9 to 0, the figure on the one higher digit increases by one.

Pressing the  key while pressing the  key changes over the indication between the higher 4 digits and lower 4 digits.

**(3) Mode select**

Each mode can be selected by the MODE key.

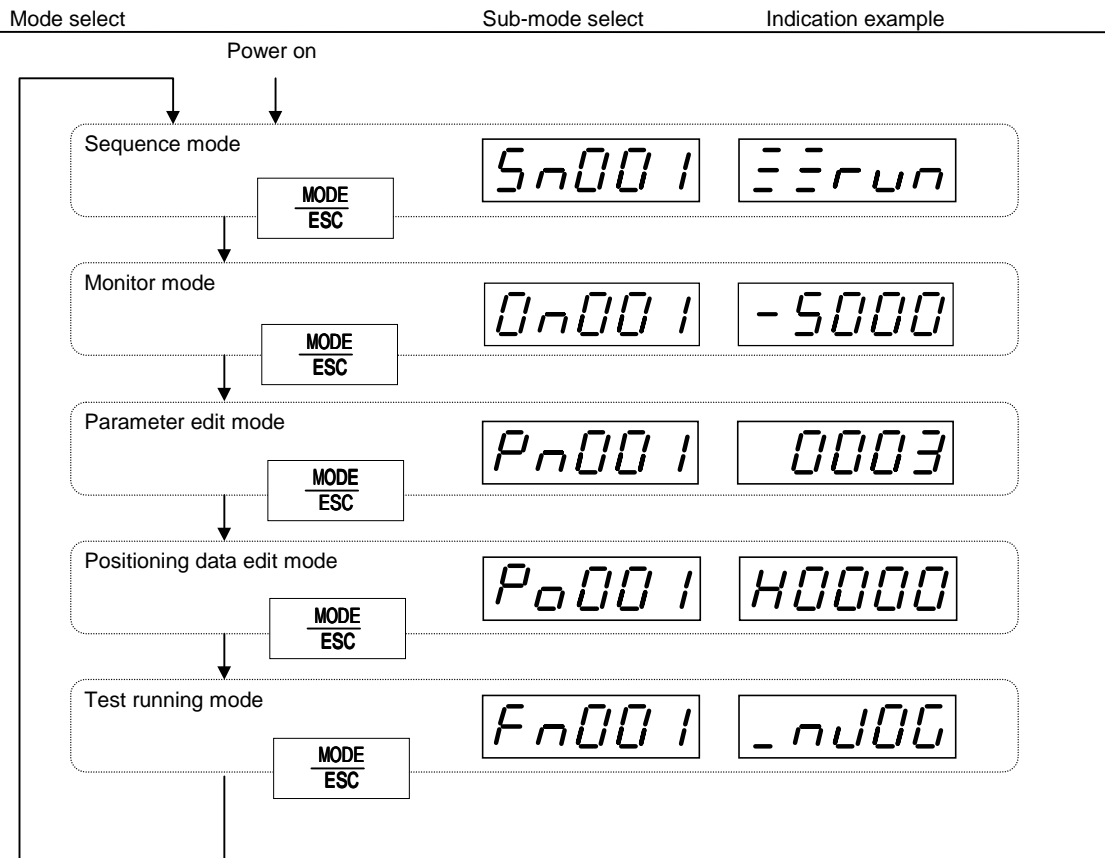

## 7.2 Function list

The setting value can be changed in parameter edit mode and positioning data edit mode.

Mode	Sub-mode	Sub-mode select	Indication example
Sequence mode	Sequence	S <sub>n</sub> 001	≡≡run
	Sub-mode	S <sub>n</sub> 002	Stby
	Alarm detection	S <sub>n</sub> 003	AL---
	Alarm history	S <sub>n</sub> 004	A1-OL
	Amplifier setting	S <sub>n</sub> 005	Ud00
	Motor setting	S <sub>n</sub> 006	CO.10
	Station No. indication	S <sub>n</sub> 007	A5009
Monitor mode	Feedback speed	0 <sub>n</sub> 001	-5000
	Command speed	0 <sub>n</sub> 002	-5000
	Average torque	0 <sub>n</sub> 003	123
	Feedback position	0 <sub>n</sub> 004	H 1234
	Command position	0 <sub>n</sub> 005	H 1234
	Deviation amount	0 <sub>n</sub> 006	H 1234
	Cumulated pulse	0 <sub>n</sub> 007	H 1234
	Peak torque	0 <sub>n</sub> 008	123
	Input voltage 1	0 <sub>n</sub> 009	- 10.0
	Input voltage 2	0 <sub>n</sub> 010	- 10.0
	LS-Z pulse	0 <sub>n</sub> 011	H 1234
	Input signal	0 <sub>n</sub> 012	H
	Output signal	0 <sub>n</sub> 013	H
	Load inertia ratio	0 <sub>n</sub> 014	100.0

Mode	Sub-mode	Sub-mode select	Indication example
Parameter edit mode	Basic para.	Pn001	H 01
	System para.	Pn002	01
Positioning data edit mode	Position data	Pa001	H0000
	Speed data	Pa002	H 00
	Timer data	Pa003	000.00
	Status	Pa004	A-COR
	M code	Pa005	FF
Test running mode	Manual feed	Fn001	JOG
	Origin return	Fn002	ORC
	Position preset	Fn003	Prt
	Alarm reset	Fn004	rt
	History initialization	Fn005	ALrt
	Parameter initialization	Fn006	PARt
	Positioning data initialization	Fn007	PorT
	Automatic offset adjust	Fn008	OFFt

### 7.3 Sequence mode

In the sequence mode, the amplifier current status and the alarm detection history can be displayed. Press the MODE key to display [ *Sn00n* ] and then press the ENT key for more than 1 [s].

- Sn001* : Sequence
- Sn002* : Sub-mode
- Sn003* : Alarm detection
- Sn004* : Alarm history
- Sn005* : Amplifier setting
- Sn006* : Motor setting
- Sn007* : Station No. indication

#### (1) Sequence

Indicates the amplifier output signal status and operation status.

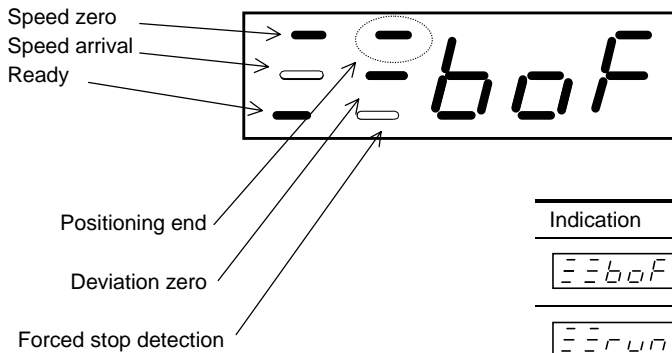
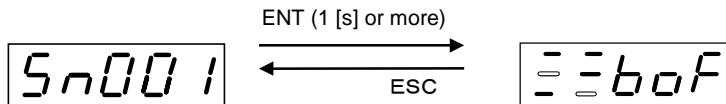

\* The corresponding LED goes on when the above each output signal is on.

Indication	Description
---boF	In base-off condition, the motor has no driving force and in free-run status. (Figure above)
---run	The motor can rotate.
---Pot	The amplifier has detected an overtravel signal in positive direction and stops.
---not	The amplifier has detected an overtravel signal in negative direction and stops.
---n0	The amplifier has received a forced stop signal and stops with the speed zero signal.

Remark : When power is applied to the amplifier, the sequence of the sequence mode is displayed. The type of indication at power on can be changed by system para. 89 setting.

System para. 89 setting

Setting	Initial indication	
0 (Initial)	Sn001	Sequence
1	Sn002	Sub-mode
2	Sn003	Alarm detection
3	Sn004	Alarm history
4	Sn005	Amplifier setting
5	Sn006	Motor setting
6	Sn007	Station No. indication

Setting	Initial indication	
7	On001	Feedback speed
8	On002	Command speed
9	On003	Average torque
10	On004	Feedback position
11	On005	Command position
12	On006	Deviation amount
13	On007	Cumulated pulse
14	On008	Peak torque
15	On009	Input voltage 1
16	On010	Input voltage 2
17	On011	LS-Z pulse
18	On012	Input signal
19	On013	Output signal
20	On014	Load inertia ratio

(2) Sub-mode

Indicates the sub-mode of the sequence mode.

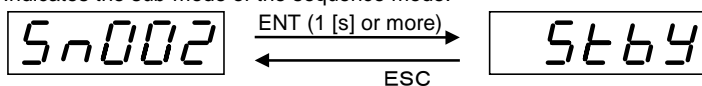

The on/off status of control input signal is indicated.

Indication	Description
bOf	In base-off condition, the motor does not have driving force and in free-run status.
StbY	The motor can rotate and is waiting the run command.
JOG	The motor can rotate and is executing manual feed.
PIn	The motor can rotate and the pulse train input is valid.
AutO	The motor can rotate and is executing positioning operation.
OrO	The motor can rotate and is executing origin return.
IntP	The motor can rotate and is executing interrupt positioning.
PCLP	The amplifier is executing deviation clear.
brEA	The motor can rotate and is measuring the brake timing.
StoP	The motor is stopping with the positioning cancel signal.
Pos	The amplifier has detected an overtravel signal in positive direction and stops.
not	The amplifier has detected an overtravel signal in negative direction and stops.

### (3) Alarm detection

The contents of current alarm can be displayed with codes. When [Sn004] is displayed, the alarm history can be displayed. When an alarm is detected, the following indication will appear.

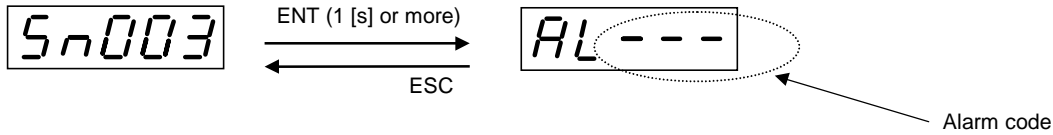

Major fault	
Indication	Description
AL SE	System error (SE)
AL OC	Overcurrent (OC)
AL OS	Overspeed (OS)
AL Lv	Undervoltage (Lv)
AL Hv	Overvoltage (Hv)
AL Et	Encoder trouble (Et)
AL Ct	Circuit trouble (Ct)
AL dE	Memory error (dE)
AL Fb	Fuse blown (Fb)
AL CE	Combination error (CE)
AL rH2	Resistor heat 2 (rH2)
AL EC	Encoder communication error (EC)
AL CtE	Cont (Control signal) error (CtE)
AL OL	Overload (OL)

Minor fault	
Indication	Description
AL rH	Resistor heat (rH)
AL OF	Deviation excessive (OF)
AL AH	Amplifier overheat (AH)
AL EH	Encoder overheat (EH)
AL AL	Absolute data lost (AL)
AL AF	Absolute data overflow (AF)
AL tE	Terminal error (tE)

Remarks : The alarm codes are indicated automatically.  
 On this indication, if the alarm detection is reset by the control input signal, the initial screen (system para. 89 setting) is displayed.  
 Resetting of alarm detection can also be executed in the test running mode.

### (4) Alarm history

The last 9 times of alarm detection history can be indicated. The indication can be scrolled by the key and key.

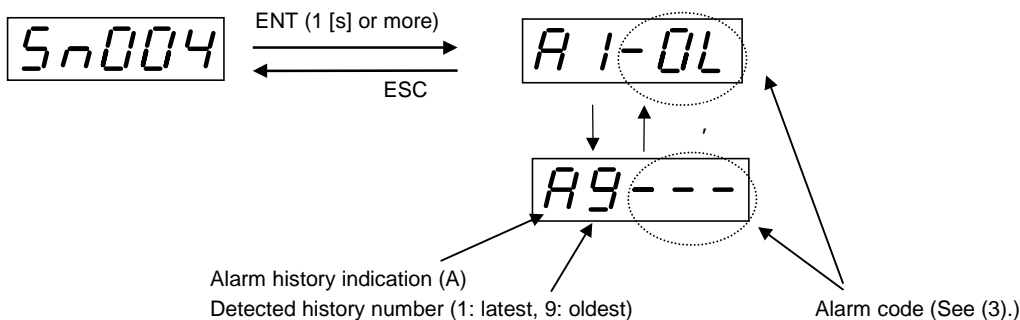

Remark : The alarm history can be deleted by the test running mode [Fn005].  
 Press the key and key simultaneously for 1 [s] or more while alarm detection is indicated to reset the alarm detection.

**(5) Amplifier setting**

The amplifier control function and connecting form are indicated.

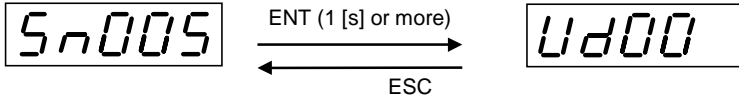

Control function (1st digit, left end digit)	
Indication	Function
U	Speed control
r	Rotation indexing (dividing)
L	Linear positioning

Main control connector (2nd digit)	
Indication	Function
d	DI/DO basic
S	SX bus

Extension connector 1 (3rd digit)	
Indication	Function
□	Not mounted
P	DI/DO extension
r	RS485

Extension connector 2 (4th digit)	
Indication	Function
□	Not mounted
t	T-link
P	Parallel
A	ANY bus
F	Multi bus

**(6) Motor setting**

The motor type and capacity being connected to the amplifier are indicated.

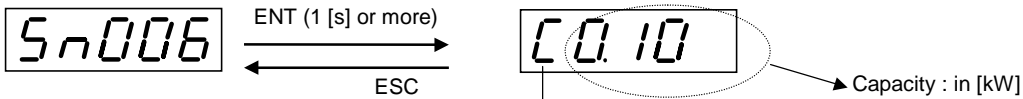

Indication	Motor type
C	Cubic type
S	Slim type
A	High stiffness
F	Flat
U	Large capacity

The sample indication above means a cubic type motor of 0.1 [kW].

**(7) Station number indication**

The communication ID of the amplifier being connected to various network and link is indicated.  
 For the setting of communication ID, see system para. 96.

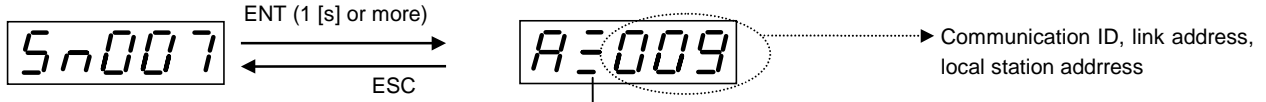

Indication	Communication interface
≡	SX bus
t	T-link
r	RS485
J	JPCN-1
0	No interface

The amplifier having no interface for communication displays [ A000 1 ].

For SX bus type, the 2nd digit indication is as follows.

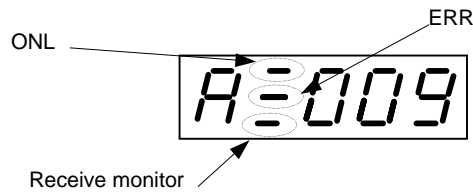

#### 7.4 Monitor mode

In the monitor mode, the motor speed or the cumulative value of input pulse can be displayed.

Display [ 0n00n ] by the MODE key and hold down the ENT key for at least 1 [s] to indicate the contents.

0n001	: Feedback speed	0n008	: Peak torque
0n002	: Command speed	0n009	: Input voltage 1
0n003	: Average torque	0n010	: Input voltage 2
0n004	: Feedback position	0n011	: LS-Z pulse
0n005	: Command position	0n012	: Input signal
0n006	: Deviation amount	0n013	: Output signal
0n007	: Cumulated pulse	0n014	: Load inertia ratio

##### (1) Feedback speed

The motor's current speed. Even if the motor is driven by the load (mechanical equipment system), the correct speed will be indicated. The indication is in 1 [r/min] unit. The negative sign is added when the motor rotates in reverse (\*).

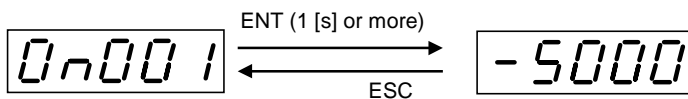

Note : (\*)

Direction of motor shaft rotation (when viewed from a point facing the drive-end of motor) is designed according to Japanese standards :

- Forward direction : Counterclockwise (CCW) rotation
- Reverse direction : Clockwise (CW) rotation

##### (2) Command speed

The speed given to the motor. The speed command voltage, multistep speed and pulse train are the command speed.

The indication is in 1 [r/min] unit. The negative sign is added when the motor rotates in reverse (clockwise viewed from shaft extension).

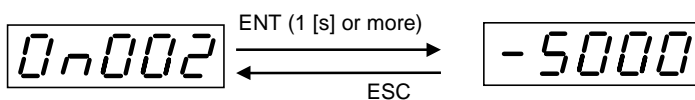

##### (3) Average torque

The motor's current load factor. The average value per second, assuming the rated torque as 100%, is indicated.

The indication is from 0% through the max. torque in 1 step. The negative sign is not added.

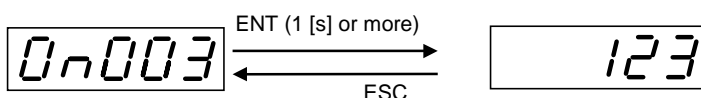

#### (4) Feedback position

The motor rotational quantity is indicated in unit quantity after pulse correction. If pulse correction is not used, the motor encoder rotation quantity itself will be indicated.

(In case of 16-bit serial encoder, 65536 pulses per rotation)

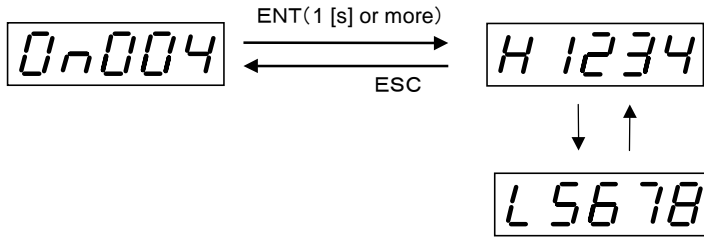

Pressing the MODE key holding down the SHIFT key interchanges the high order 4 digits and low order 4 digits.

Remarks : If the rotating direction has been altered by system para. 80, an increase from the current position raises the reading.

The maximum positive count of 99,999,999 is followed by 0. The maximum negative count of -99,999,999 is followed by 0. Hence, the count becomes 0 every  $\pm 100,000,000$ .

The indication is correct even when rotated by the load (mechanical equipment system).

4 digits preceded by "H" are high order 4 digits, and those by "L" are low order 4 digits. In case of a negative value, "H" (or "L") and -(minus sign) appears alternately.

#### (5) Command position

The position of motor directed by the amplifier is displayed in unit quantity after pulse correction.

After a target position is attained, if the run command is turned off and the motor is rotated by the load (mechanical equipment system), a correct position is not displayed.

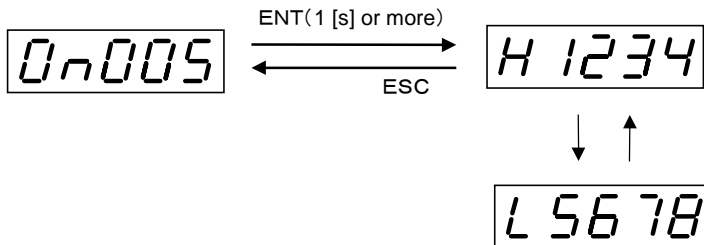

Pressing the MODE key holding down the SHIFT key interchanges the high order 4 digits and low order 4 digits.

#### (6) Deviation amount

Displays the difference between command position and feedback position. The deviation is displayed in terms of encoder pulse count.

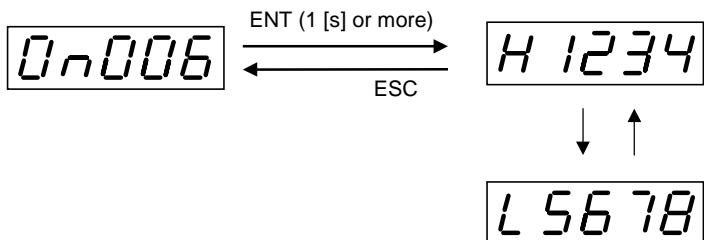

Pressing the MODE key holding down the SHIFT key interchanges the high order 4 digits and low order 4 digits.

**(7) Cumulated pulse**

Displays the number of pulse trains inputted to the pulse train input terminal. Inputting the forward pulses increases the integrated value and inputting the reverse pulses decreases the integrated value.

In case of two 90° phase-different signals, each edge is counted (quadrupling). The count increases if B phase is in lead.

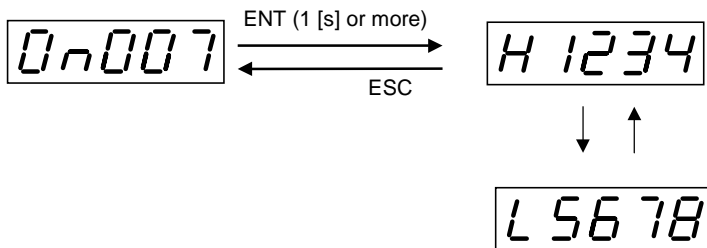

Pressing the MODE key holding down the SHIFT key interchanges the high order 4 digits and low order 4 digits.

Remarks : The maximum positive count of 99,999,999 is followed by 0. The maximum negative count of -99,999,999 is followed by 0. Hence, the count becomes 0 every ± 100,000,000.

4 digits preceded by "H" are high order 4 digits, and those by "L" are low order 4 digits. In case of a negative value, "H" (or "L") and - (minus sign) blink alternately.

**(8) Peak torque**

Current load factor of motor. The peak value is displayed every other second in percentage assuming the rated torque as 100%. The indication is from 0% to maximum torque without minus sign.

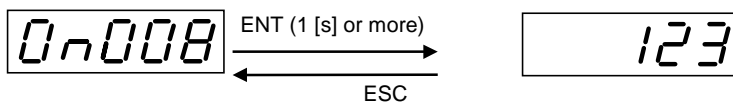

**(9) Input voltage 1**

Indicates the input voltage at the control input terminal [NREF] in 0.1 [V] steps. "-" denotes a negative voltage.

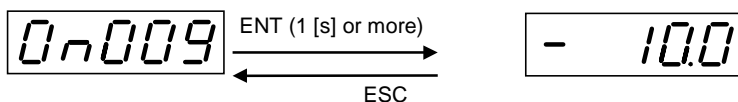

\* Some amplifiers do not have the control input [NREF] terminal.

**(10) Input voltage 2**

Indicates the input voltage at the control input terminal [TREF] in 0.1 [V] steps. "-" denotes a negative voltage.

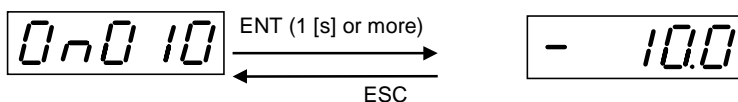

\* Some amplifiers do not have the control input [TREF] terminal.

**(11) LS-Z pulse**

Displays a pulse count from when the origin LS signal has turned off at origin return until when Z-phase of motor encoder has been detected. The indication is updated at every origin return action. Since the value is in the origin return direction, there is no -(minus sign).

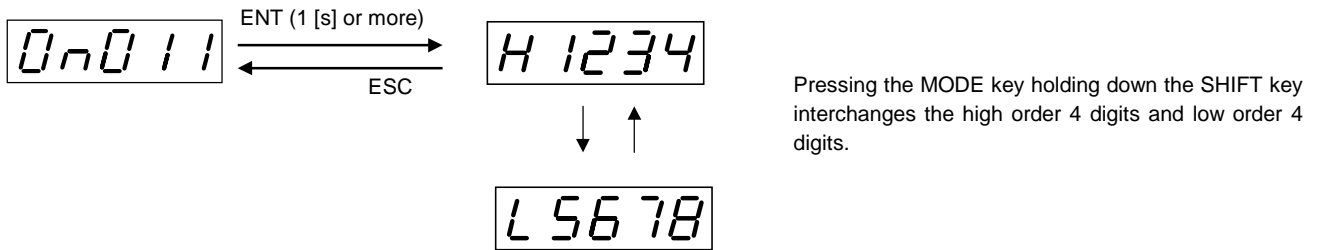

**(12) Input signal**

Displays whether the control input signals to the amplifier are turned on or off. If signals are turned on, corresponding LEDs are lit.

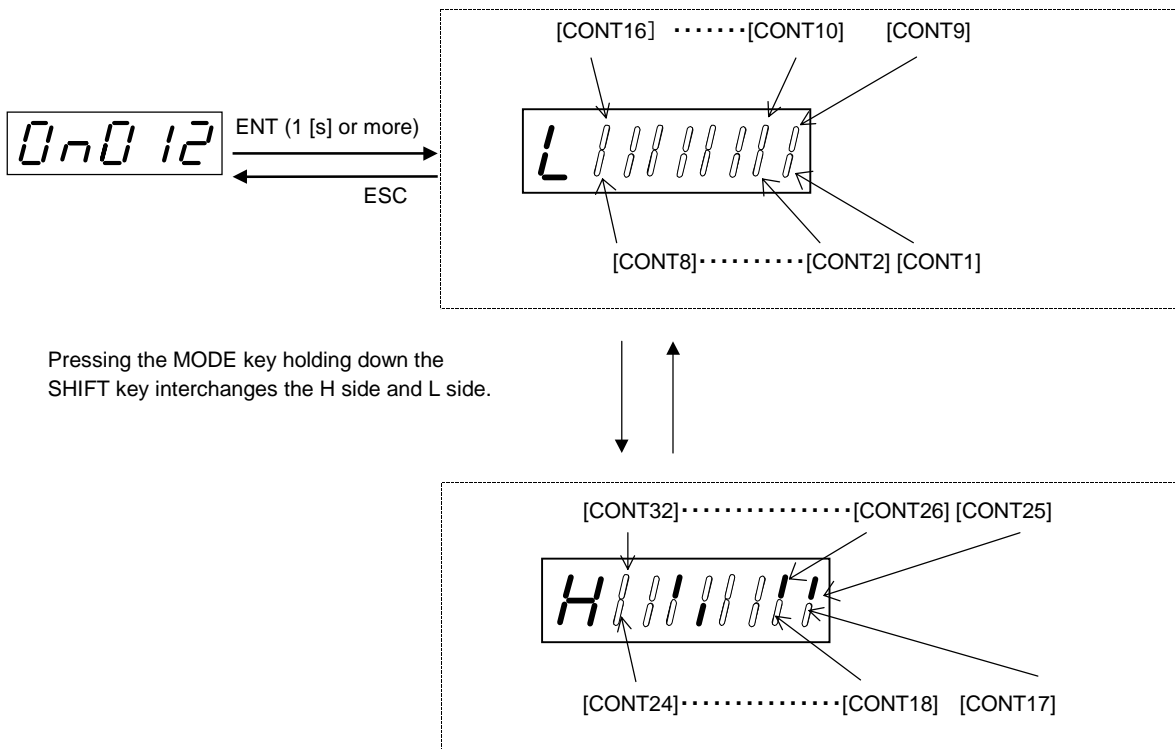

Pressing the MODE key holding down the SHIFT key interchanges the H side and L side.

**Note :** The number of control input signals depends on the amplifier type.

**(13) Output signal**

Displays whether the control output signals from the amplifier are turned on or off. If signals are turned on, corresponding LEDs are lit.

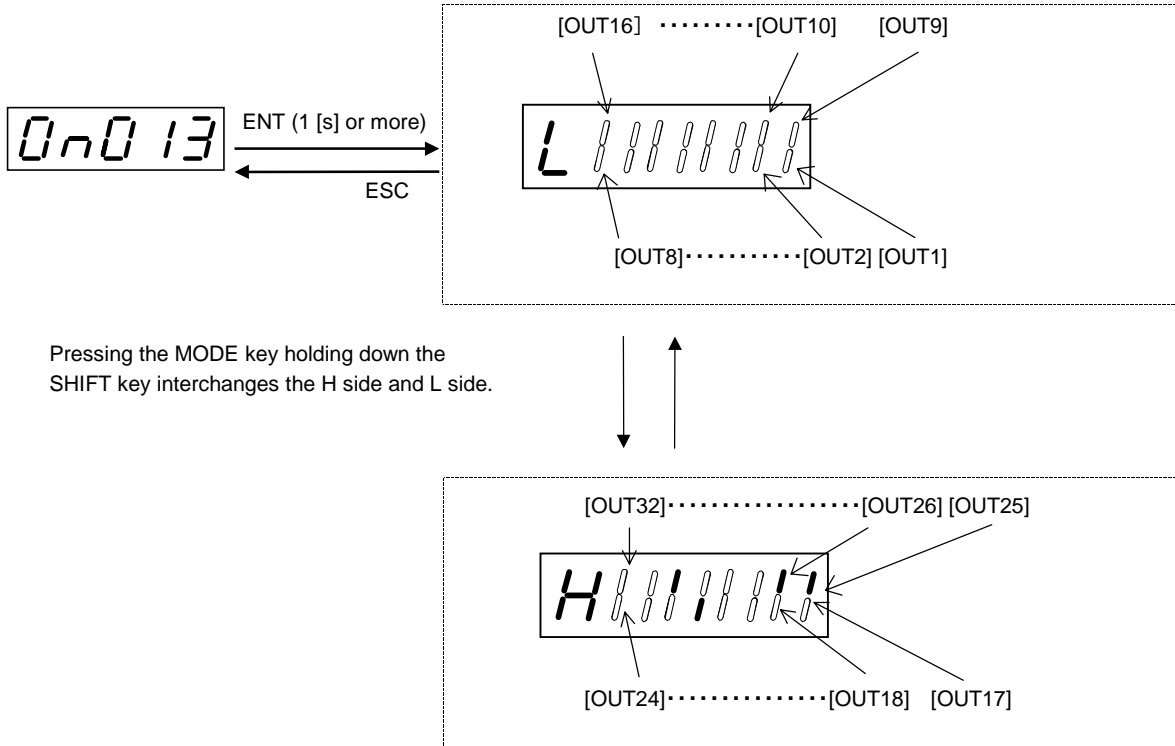

Pressing the MODE key holding down the SHIFT key interchanges the H side and L side.

**Note :** Depending on the amplifier type, the number of control output signals changes.

**(14) Load inertia ratio**

Displays the load inertia ratio recognized by the amplifier regardless of the tuning method (basic para. 31).

$$(\text{Load inertia ratio}) = \frac{(\text{Moment of inertia recognized by amplifier})}{(\text{Moment of inertia of motor})}$$

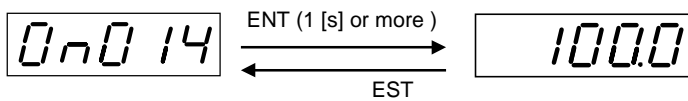

Displays the magnification (in 0.1 step) of the moment of inertia of the motor.

### 7.5 Parameter edit mode

In the parameter edit mode, basic paras. and system paras. can be edited.

Display [ Pn000n ] by the MODE key and hold down the ENT key for at least 1 [s] to select the basic para. or system para.

Pn001 : Basic para.

Pn002 : System para.

By the key or key, select a number of para. By pressing the ENT key, its contents can be edited.

PP0nn : Basic or system para. number

#### (1) Basic parameter

In basic para., rather frequently used contents are registered. Changed setting of almost all the basic para. immediately affects the amplifier and motor actions.

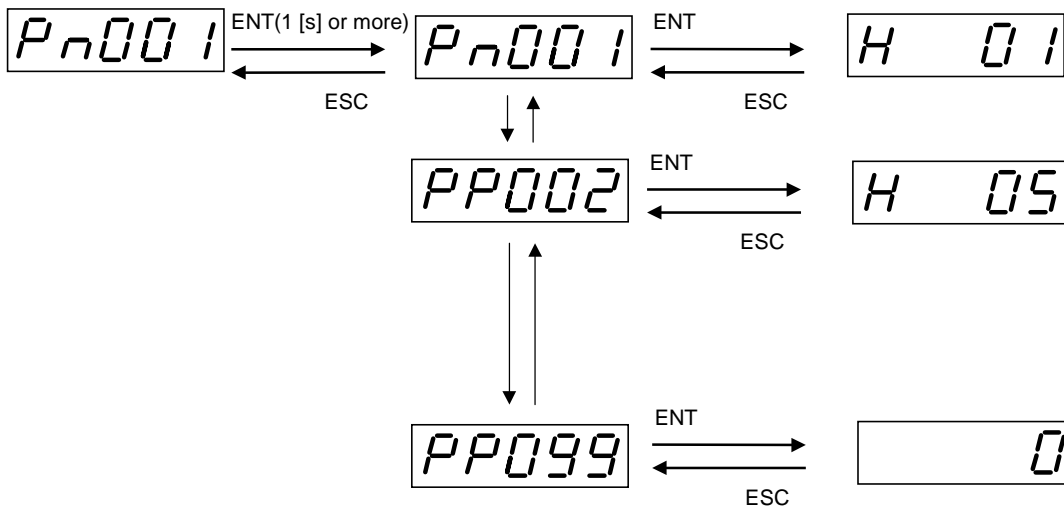

#### (2) System parameter

System para. register the functions of input/output terminals and other contents related to system setting. Changed setting of almost all the system para. is valid only after turning off and on power.

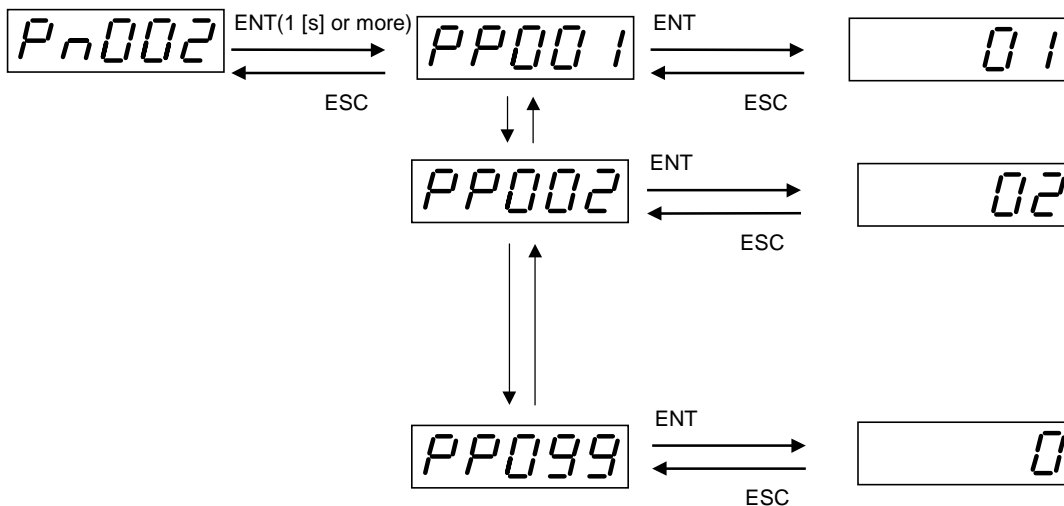

**(3) Indication and editing**

The indication and editing methods for para. are as follows.

**Value indication**

A value of unsigned 5 digits or signed 4 digits or less is displayed as it is.



Left example shows a value of 2 digits is selected.

For clearly indicating the number of digits of a selectable value, zeroes of other columns are suppressed.

A signed value of 5 digits or more is preceded by "H" or "L".

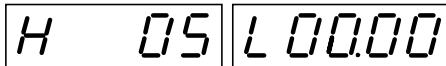

The above example shows a value has 6 digits. (The value will be 500.00.) For interchanging the "H" side and "L" side, press the MODE key holding down the SHIFT key.

**Sign indication**

In case of data with minus sign, "H" (or "L") and "-" blink alternately.

In case of data with plus sign, "H" (or "L") indication blinks.

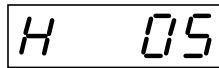

Alternately lights

Example : Data with minus sign (H side)

**Editing a value**

After reading a para., 1 digit or sign blinks at about 1 [s] intervals, prompting you to change that part.

Pressing the key or key changes the value. As for the sign, pressing the key or key while the cursor is located at "H" selects a plus sign ("H" and blank) or a minus sign ("H" and "-").

If 9 is followed up by 0, the value at the immediately upper place increases by 1. If 0 is followed down by 9, the value at the immediately upper place decreases by 1.

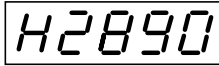

Example : 9 is followed up by 0 to give 2900.

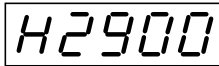

Note that there is no borrow nor carry from "H" side to "L" side or reversely.

The shifting order is as follows.

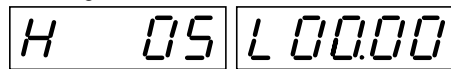

(2) (3) (1) (4) (5)

- (1) Reading a para. allows to change the LSD(\*) of "H" side.
- (2) Shifting allows to change the sign.
- (3) Shifting locates the cursor to the MSD(\*) of "H" side. Shifting repeatedly goes to the right and then sequentially circulates within the display range of "H" side.
- (4) To jump from the "H" side to the "L" side, press the MODE key holding down the SHIFT key. On the "L" side, the MSD can be changed first.
- (5) Each press of the SHIFT key moves the cursor to the right. The LSD is followed by the MSD within the "L" side.

**Storing the value**

Holding down the ENT key for at least 1 [s] stores the value, blinking all digits simultaneously 3 times. The stored value remains displayed.

Pressing the ESC key resumes the para. selecting screen.

**Value beyond specified range**









A value can be inputted within the range from minimum to maximum specified for each para.

A value beyond the specified range cannot be inputted.

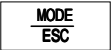
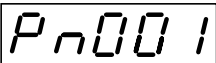
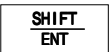
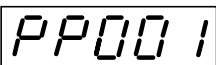
(\*) LSD : Least significant digit MSD : Most significant digit

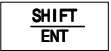
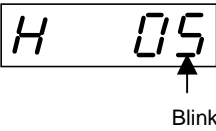
Example of editing

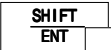
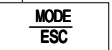
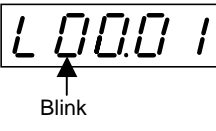
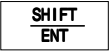
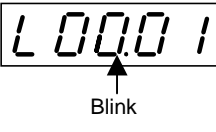
Let us change the setting of basic para. 2 "Manual feed speed 2" to 1.0.

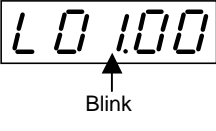
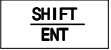
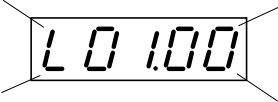
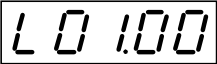
Key operation	Indication	Remarks
		The feedback speed monitor is displayed.
		Resumes the mode selection.
		Press the MODE key for selecting the parameter. edit mode.
 1 [s] or more		Hold down the ENT key for at least 1 [s] for display the para. 01.
		Select the basic para. 2.
		Pressing the ENT key reads the setting contents. The LSD blinks. (Two MSDs of initial value 500.00 are displayed.)
		Decrease the value to 0.
 		Press the MODE key holding down the SHIFT key to display the "L" side (low order 4 digits).
		Press the SHIFT key to shift the cursor to the adjacent digit on the right.
		Set the value to 1. Likewise, change the LSD to 0.
 1 [s] or more		Hold down the ENT key for at least 1 [s] to store the new value.
		Storing the value keeps it displayed. Pressing the ESC key resumes the para. number selecting screen.

## 7.6 Positioning data edit mode

The positioning data edit mode allows to edit the position data, speed data, timer data, status and M code. These 5 data compose 1 point of positioning data.

Press the MODE key to display [ *Po00n* ], and hold down the ENT key for at least 1 [s] to select the data to edit.

*Po001* : Position data  
*Po002* : Speed data  
*Po003* : Timer data  
*Po004* : Status  
*Po005* : M code

Then, press the  key or  key to select the number of positioning data to edit first.

Pressing the ENT key allows to edit its contents.

*PP0nn* : Positioning data number

### (1) Position data ( *Po001* )

As the position data, set the motor stop position. The setting range is -79,999,999 to 79,999,999 in 1 step.

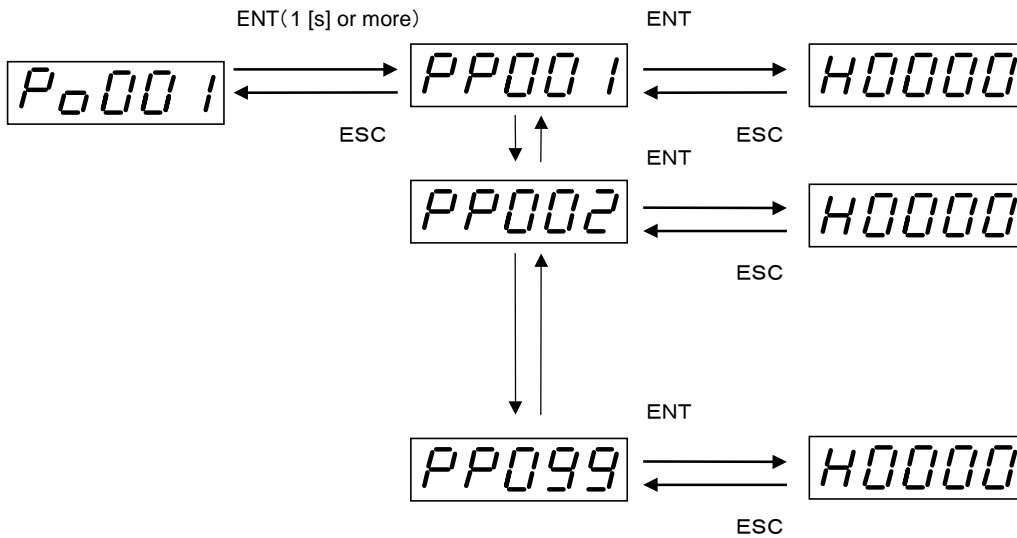

**(2) Speed data ( P<sub>0002</sub> )**

As the speed data, set the moving speed up to the stop position data in speed of motor shaft. The setting range is up to the maximum speed of motor in 0.01 [r/min] step.

(0.00 [r/min] cannot be selected.)

**(3) Timer data ( P<sub>0003</sub> )**

As the timer data, set the timer value after arriving a stop position. The setting range is 0.00 to 999.99 [s] in 0.01 step.

**(4) Status ( P<sub>0004</sub> )**

Set various information incidental to positioning data. It can be changed by the key or key.

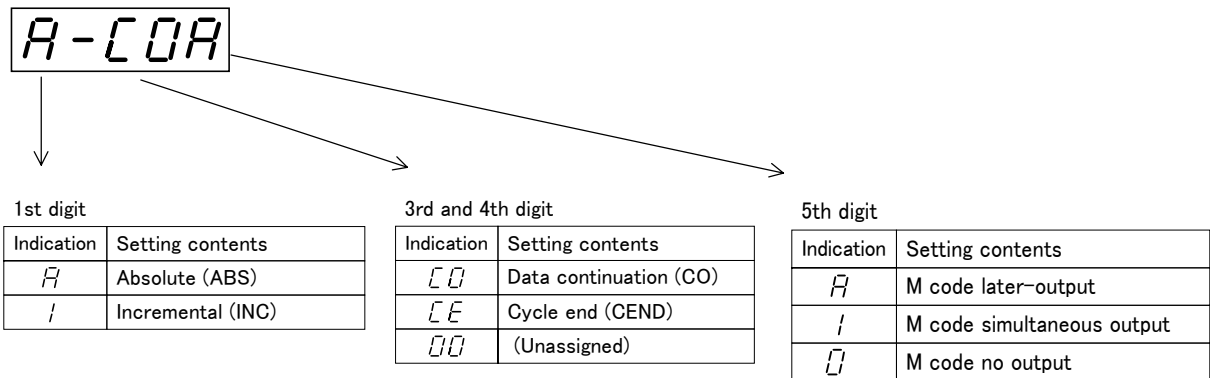

**(5) M code ( P<sub>0005</sub> )**

An M code to output by executing the positioning data can be edited. The setting range is 00 to FF in hexadecimal notation. (An arbitrary value is specified in 1 step.) Each digit is changeable by the key or key.

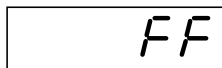

### 7.7 Test running mode

In the test running mode, keying on the keypad panel can rotate the motor or reset the different items.

Upon displaying [ *F<sub>n</sub>000<sub>n</sub>* ] by the MODE key, holding down the ENT key for at least 1 [s] executes a test running.

<i>F<sub>n</sub>0001</i>	: Manual feed	<i>F<sub>n</sub>0005</i>	: History initialization
<i>F<sub>n</sub>0002</i>	: Origin return	<i>F<sub>n</sub>0006</i>	: Parameter initialization.
<i>F<sub>n</sub>0003</i>	: Position preset	<i>F<sub>n</sub>0007</i>	: Positioning data initialization
<i>F<sub>n</sub>0004</i>	: Alarm reset	<i>F<sub>n</sub>0008</i>	: Automatic offset adjust

#### (1) Manual feed ( *F<sub>n</sub>0001* )

So long as a key on the keypad panel is pressed, the motor rotates. The motor speed is as set by basic para. 1.

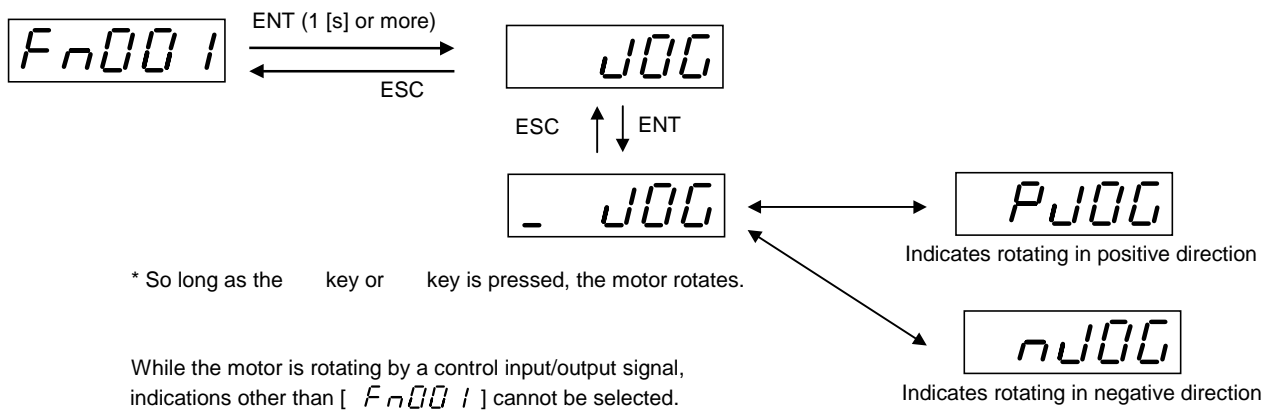

#### (2) Origin return ( *F<sub>n</sub>0002* )

Keying on the keypad panel performs an origin return. The origin return is made according to basic para. 72 to 77. Change of basic para. 72 and 73 settings is valid only after turning off and on power.

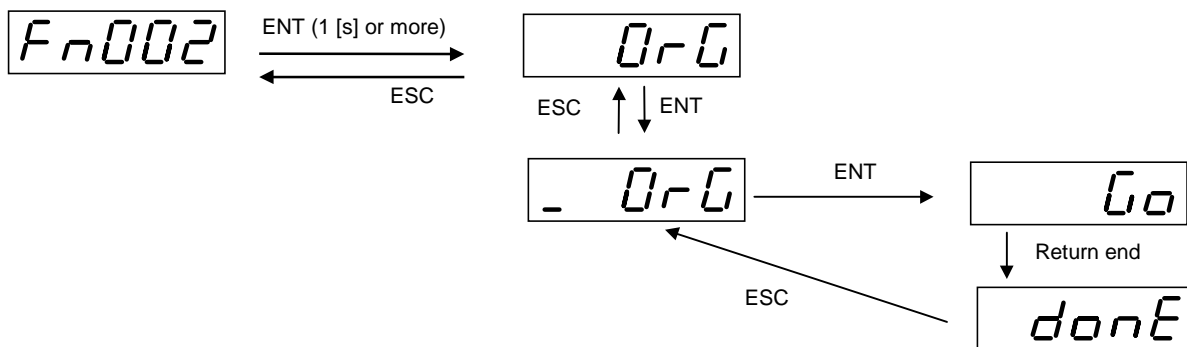

After the end of origin return, the indication remains [ *done* ]. Pressing the ESC key resumes a sub-mode selection.

**(3) Position preset (Fn003)**

The current position of motor can be preset. The following alarm detection can be reset.

- ABS data loss
- Absolute data overflow

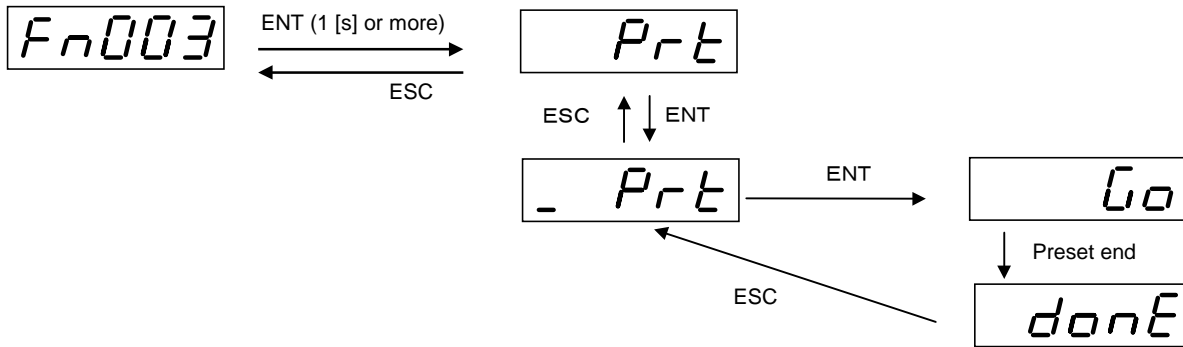

The current position is set by basic para. 80.  
Position preset cannot be made while the motor is rotating

**(4) Alarm reset (Fn004)**

Resets the alarm detected by the amplifier.

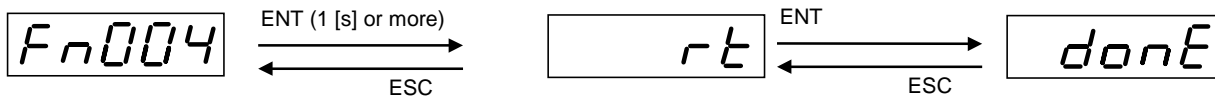

**(5) History initialization (Fn005)**

Deletes the history of alarms detected held by the amplifier.

This history can be monitored by a sequence mode of [Sn004].

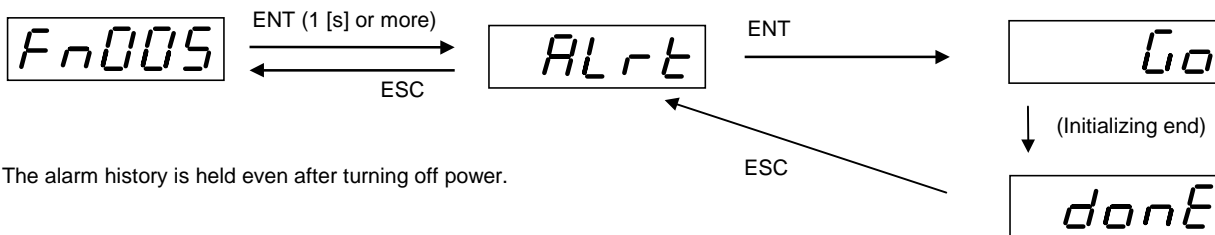

The alarm history is held even after turning off power.

**(6) Parameter initialization (Fn006)**

Initializes the basic para. and system para.

\* After initializing, be sure to turn off and on power.

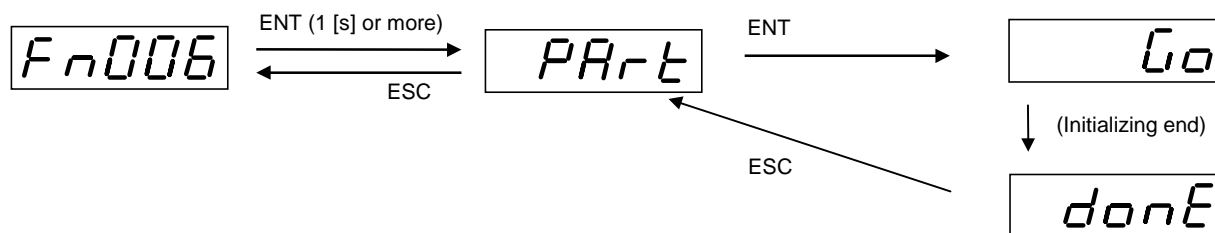

### (7) Positioning data initialization (Fn007)

Initializes all positioning data.

\* After initializing, be sure to turn off and on power.

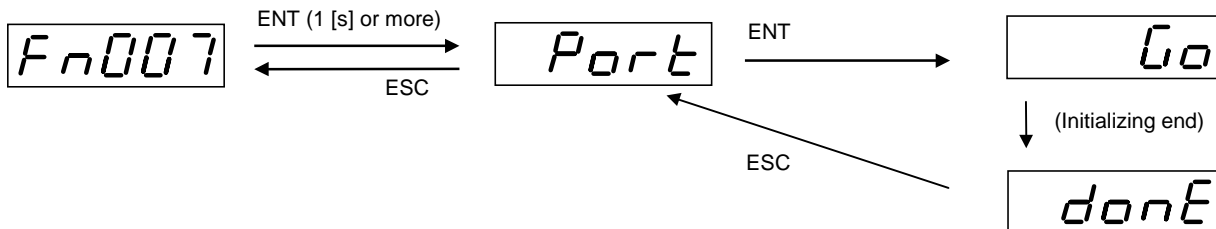

### (8) Automatic offset adjust (Fn008)

Sets the input voltage to the control input terminals [NREF] and [TREF] at 0 [V].

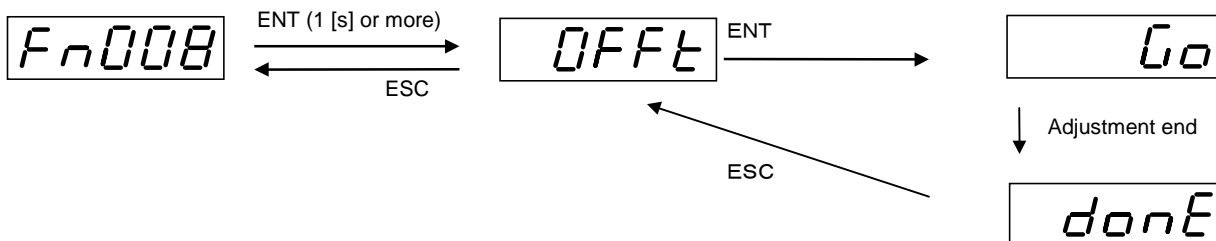

**Automatic offset adjust is only valid for RYS-L basic type. SX bus, T-link and RS485 interface type do not have the analog voltage input terminal.**

Motor can be rotated with the analog speed command voltage, when FWD (or REV) signal command turns off all of X1, X2 and X3 of multispeed selections.

When the speed command voltage is placed as nearly 0 [V], motor may be rotates slowly.

Adjusting procedure of offset voltage is as follows :

- (1) Sets 0 [V] at the terminal [NREF].  
Whether the run command is given or not has no influence.
- (2) Select [Fn008] on the keypad panel and press the ENT key, then the offset can be adjusted automatically.
- (3) Make sure that the motor will not rotate even if the run command is on.

Remarks:

Both the terminal [TREF] and [NREF] can be adjusted simultaneously by the automatic offset adjust.

The adjustment result will be stored in system para. 64 and 66.

Along with the change of ambient environment, the offset adjust may be required again.

With the setting of system para. 81, the operation at stoppage can be selected. When the servo lock is selected, the motor can be stopped by the servo lock even in speed control mode. However, when the host controller is controlling the amplifier using the speed command voltage and freq. dividing output pulse (feedback), do not select the servo lock.

## 8. SETTING OF POSITIONING DATA

### 8.1 Setting contents

99 points of positioning data can be registered in the amplifier.  
 Each positioning data registers contents of one positioning action.  
 Positioning data are numbered 1 to 99 sequentially (address Nos.).



Externally specifying an address No. and applying an auto start signal [START] starts positioning action according to its setting contents.

The setting contents of one positioning data are as follows.

#### Setting contents of positioning data

Position data (stop position)	-79999999 to 0 to 79999999 (in 1 step)[x unit q'ty]
Speed data (motor speed)	0.01 to max. speed [r/min] (in 0.01 step)
Timer data (dwell time)	0.00 to 655.35 [s] (in 0.01 step)
Status (command method)	ABS/INC
Status (step mode)	CO (data continuation)/CEND (cycle end)
M code	00 to FF (in 1 step)
M code output	Simultaneous output (while positioning)/Later-output (after the end of positioning)

### (1) Position data (stop position)

Specifies the position where the motor stops if the status is ABS, or the increment to move if it is INC.

In order that the mechanical equipment system moves as many quantity (20.00 [mm]) as setting (ex. 20.00) of position data, the para. must be set as follows.

#### Basic parameter 91, 92

Para.	Name	Setting range	Initial value	Change
91	Command pulse correction $\alpha$ ( CPC $\alpha$ )	1 to 32767 (in 1 step)	8	Always
92	Command pulse correction ( CPC )	1 to 32767 (in 1 step)	1	Always

#### Basic parameter 95

Para.	Name	Setting range	Initial value	Change
95	Decimal point location in position data	0 : 1, 1 : 0.1, 2 : 0.01, 3 : 0.001, 4 : 0.0001, 5 : 0.00001	0	Always

### (2) Speed data (motor speed)

Sets the motor speed until it reaches the position set by the position data.

The setting is the speed [r/min] of the motor shaft and not the moving speed of the mechanical equipment system.

Setting is available from min. of 0.01 to max. motor speed in 0.01 [r/min] step.

### (3) Timer data (dwell time)

A positioning end signal [PSET] is externally outputted in a lapse of time set by the timer data after arriving the position set by the position data.

Setting is available from 0.00 [s] to 655.35 [s] in 0.01 [s] step.

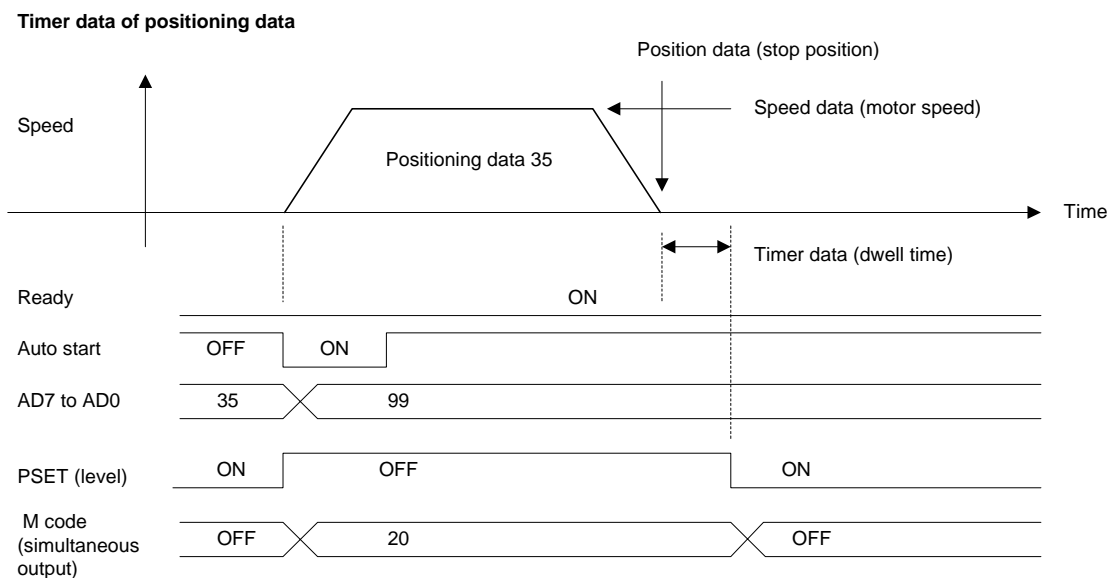

\* The elapsed time of the timer data is included in the executing time of positioning data.

**(4) Status**

The status setting includes ABS/INC and CO/CEND.  
CO/CEND may not be specified.

- Absolute (ABS) / Incremental (INC)

If ABS is specified, the motor rotates until the current position coincides with the position set by position data.  
If started by the position data set at 0 and the positioning data set at ABS, the motor will rotate up to 0 point wherever the current position is.

If INC is specified, the motor will rotate by the quantity of the position data setting from the current position.  
If the position data are set at 100.0, a movement occurs by 100.0 in the positive direction from the current position.

- Data continuation (CO)

If started by positioning data with CO specified, after completion of positioning with that data, a movement automatically occurs according to setting contents of the next positioning data.

For example, if CO is specified in positioning data No. 56, the movement is pursued according to positioning data No. 57.  
Likewise, if CO is specified in No. 57, the movement is pursued according to No. 58.

If the timer data are 0.00 [s], the movement speed changes continuously.

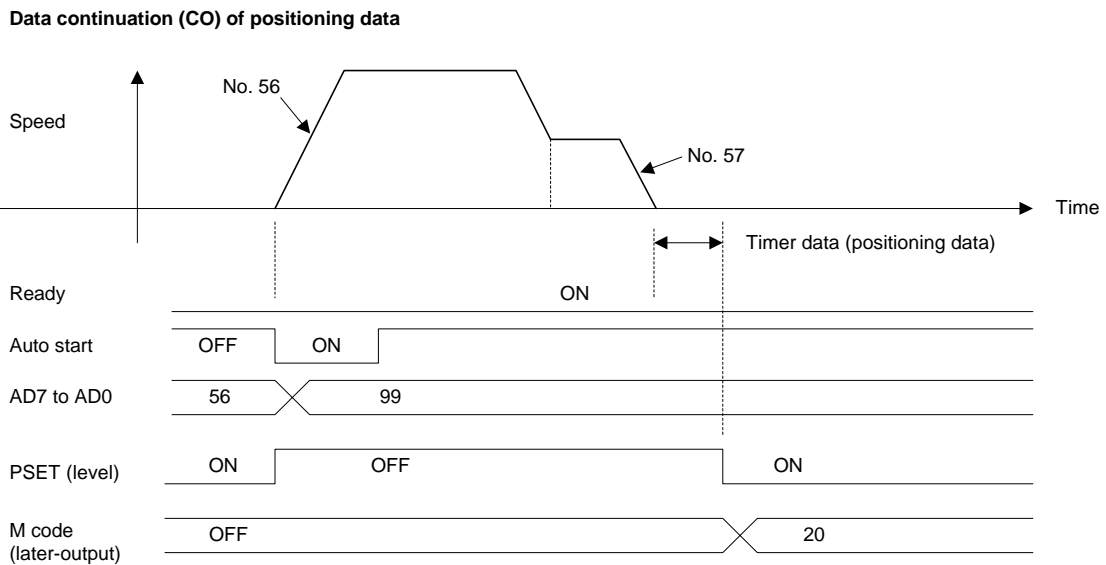

\* The elapsed time of the timer data is included in the executing time of positioning data.

If the timer data are set at 0.00 [s], the speed changes at the position set by position data.

(1) When data with high-speed setting are continued to data with low-speed setting, the speed will have already been reduced according to the next speed data at the position set by position data.

(2) When data with low-speed setting are continued to data with high-speed setting, the acceleration starts at the position set by position data.

The data continuation is executed in the order of positioning data numbers (addresses).

If started with intermediate positioning data of data continuation, preceding positioning data are ignored. (An execution will not trace back to preceding positioning data.)

If started with positioning data at No. 17 as shown below, the setting contents of No. 16 are ignored.

Data continuation of positioning data

Address No.	Command method	Step mode	Stop position	Motor speed	M code	M code output
16	ABS	CO	0.00	0.00		
17	ABS	CO	5000.00	5000.00		
18	ABS	CO	5200.00	500.00		
19	ABS		5400.00	50.00		

- Cycle end (CEND)

At the end of movement with positioning data where CEND is specified, a cycle end signal (CEND) assigned to OUT is outputted.

Data continuation (CO) and cycle end (CEND) cannot simultaneously be specified in the same positioning data.

For cycle end, see 5.5.1 Auto start.

- M code

If M codes are specified among the positioning data, arbitrary values can externally be outputted while positioning (simultaneous output) or after the end of positioning (later-output).

For M codes, see 5.5.5 M code.

## 8.2 Starting

This section explains the methods how to carry out positioning with contents of positioning data.

The auto start signal [START] is valid even if the origin return and position preset have not been completed.

Positioning cannot be carried out in the test running mode using keypad panel.

### (1) Starting

(a) Basic type (DI/DO position)

Set a value out of 01 to 99D in BCD or 01 to 63H in binary code to address AD7 to AD0 of Connector 3 (CN3).

Positioning starts at the ON edge of auto start [START] signal.

(b) SX bus (SX bus direct connection)

Set a value out of 01 to 63H in binary code in the positioning data No. setting area of IQ area.

Positioning starts at the ON edge of auto start [START] signal.

(c) T-link (T-link direct connection)

Set a value out of 01 to 99 in BCD or binary code in the address specified area.

Positioning starts at the ON edge of auto start [START] signal.

(d) General-purpose communication (RS485 interface)

The auto start command (CM : 34H, SCM : 3A) and positioning data No. setting command (CM : 34H, SCM : 38H) are available.

The auto start signal is assigned to Connector 1 (CN1) at factory-setting.

To use on this status, set a value using the positioning data No. setting command.

Positioning starts at the ON edge of auto start [START] signal.

### (2) Stopping

The motor decelerates before the position set by position data and automatically stops at the set position.

The followings show how to stop forcibly after starting a movement.

- Turn off the run command [RUN].
- Turn off the forced stop [EMG] (top priority always).
- Turn on a positioning cancel.
- Turn off an external fault input (top priority always).
- Turn on a temporary stop (turning it off resumes the remainder of action).
- Turn on a free-run [BX] signal.

After starting a movement, it may not reach the position set by the position data for the following reasons.

Soft OT, +OT, -OT signal detected.

Limiter detected.

### (3) Incidental functions

The setting of position data can be directly specified from outside.

- Immediate positioning (see 5.5.3).

Successive positioning data can sequentially be executed.

- Sequential start (see 5.5.1).

The current shaft position can be detected.

- Current position output (see 5.5.4).
- Fixed/passing point detection 1, 2 (see 5.7.2).
- Origin return end (see 5.4.1).

### 8.3 Setting change

Setting contents of positioning data can be changed by the following method.

- Editing is available by the keypad panel on the amplifier.
- Editing is available by PC loader.
- Position data can be changed by the teaching signal assigned to a CONT terminal.
- An amplifier connectable through various links and communication can edit positioning data.

Setting of system para. 95 can limit editing of positioning data from PC loader or keypad panel.

By the edit permit command signal assigned to a CONT terminal, editing can be limited by external control input signal.

After setting the positioning data, changing the decimal point position of basic para. 95 may increase (decrease) the setting value. 8 significant digits are not changed.

### 8.4 Response time

The response time for auto start (operation according to positioning data) is as follows.

#### (1) Basic type (DI/DO position)

Auto start [START] terminal sampling time	Approx. 2 [ms]
Auto start software processing time	Approx. 4 [ms]
<hr/>	
Total	Approx. 6 [ms]

- \* Approx. 2 [ms] of asynchronous time before and after sampling time is added.

#### (2) SX bus (SX bus direct connection)

Auto start [START] terminal sampling time	Approx. 2 [ms]
Auto start software processing time	Approx. 4 [ms]
<hr/>	
Total	Approx. 6 [ms]

- \* The calculation cycle of SX bus type itself, the bus tact, etc. are added.

#### (3) T-link (T-link direct connection)

Auto start [START] terminal sampling time	Approx. 2 [ms]
Auto start software processing time	Approx. 4 [ms]
<hr/>	
Total	Approx. 6 [ms]

- \* The PLC scan time and T-link refresh time (10 [ms]) are added.

#### (4) General-purpose communication (RS485 interface)

Auto start [START] terminal sampling time	Approx. 2 [ms]
Auto start software processing time	Approx. 4 [ms]
<hr/>	
Total	Approx. 6 [ms]

- \* The starting time is within 5 [ms] after receipt of the auto start command.

## 9. TEST (TRIAL) RUNNING OPERATION

### 9.1 Preparation

#### (1) Preparation

A test running is carried out upon connecting the amplifier and motor. For the wiring method, see 4. TERMINAL DIAGRAMS AND WIRING. For the test running, the motor is not connected to the mechanical equipment system and, when the operation is normal, it is connected to the mechanical equipment system.

##### (a) Main circuit power input

The amplifier power supply includes main circuit power input (L1, L2, L3) and control power input (L1C, L2C). The amplifier can be operated even if the control power input terminal is not connected to the power supply.

##### (b) Main circuit power supply

Connect the motor power line to the (U, V, W,  $\frac{\pm}{\pm}$ ) terminals on the amplifier terminal block (board). Changing the phase sequence cannot change the motor rotational direction.

##### (c) Encoder wiring

Connect the encoder for the motor to CN2 on the amplifier using a specified cable.

##### (d) Control input/output wiring

Do not connect CN1 and CN3 of the amplifier, when the test running temporary.

#### (2) Power supply

Supply the main circuit power to the amplifier. If the status is as follows, the amplifier is operating properly.

##### ■ LED indication

When power is supplied, the "CHARGE" LED below the keypad panel of amplifier is lit red.

##### ■ 7-segment indication

Periods for all of five 7-segment digits light once simultaneously.

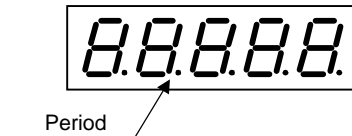

##### • Basic type (DI/DO position)

If the para. are as set at factory, the sequence of sequence mode appears.

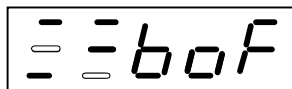

##### • SX bus (SX bus direct connection)

If the para. are as set at factory, the station number of sequence mode appears.

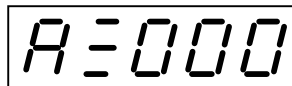

##### • T-link (T-link direct connection)

If the para. are as set at factory, the station number of sequence mode appears.

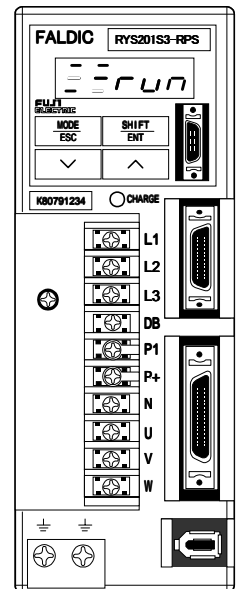
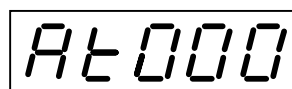

• General-purpose communication (RS485 interface)

If the para. are as set at factory, the station number of sequence mode appears.



Remark : The "CHARGE" LED lights with either the main circuit power supply or control power supply on.  
Depending on the system para. setting, the ABS data lost [AL] or other alarms may occur but it is not abnormal.

### (3) Absolute system [ABS]

If an absolute system is used, carry out a start up in the following procedure.

#### (a) Battery

Install a battery (WSB-S type) on the amplifier as follows.

(i) Pull open downward the cover for the battery holder located on the right side of amplifier. (For the amplifier of 2 [kW] or more, pull open the cover toward this side.)

(ii) In the battery holder, there is a connector which is to be engaged with the connector provided for the battery.

(iii) Engage the connectors and close the cover in place.

(Be sure to connect while power is off.)

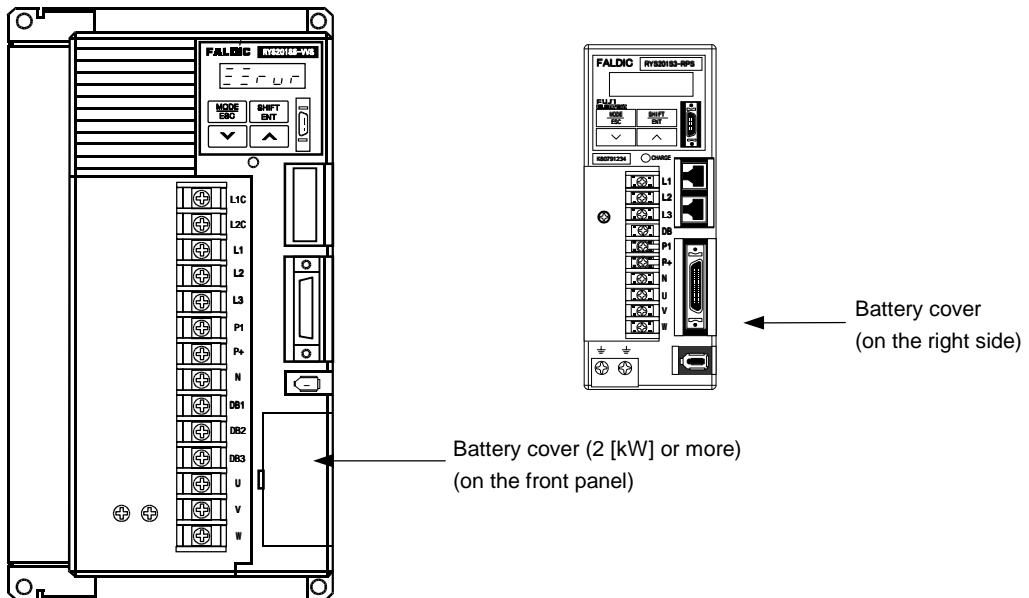

#### (b) System para. 99

Turn on the power supply, and set system para. 99 to "1".

(c) Turning off power

To validate the set value of system para. 99, turn off and on power. Make sure the 7-segment on the keypad panel is extinguished (goes out) before turning on again.

(d) Power supply

Supplying power produces an alarm "Absolute data lost". This is because the current position data of encoder has been lost.



(e) Resetting the detected alarm

Execute the position preset [Fn003] in the test running mode to reset the alarm detection of "Absolute data lost." This alarm detection cannot be reset by [RST]. Thereafter, the ABS system is validated. Either execute the origin return action or input the position preset signal at the normal position.

(4) Station No. setting

- Basic type (DI/DO position)
- Station No. setting is not necessary.
- SX bus type (SX bus direct connection)
- Specifies the station No. in the system definition of D300win. Use the amplifier as it is with the station No. "0". (Use it as the system para. 96 setting at "0" as it is.)  
Set just the same station No. to system para. 96 to make the fail-soft function of SX bus valid.
- T-link (T-link direct connection)
- Set the T-link address to system para. 96.
- General-purpose communication (RS485 interface)
- Set the station No. 01 to 31 of amplifier to system para. 96.  
Set 01 to 1FH in the message.

9.2 Motor

Check the motor model type and rated output [kW].

Key operation	Indication (example)	Remark
		The sequence is displayed.
		By the ESC key, select the sub-mode.
		By the key or key, select [Sn006].
		Pressing the ENT key for at least 1 [s] displays the motor model type. GYC type ("C" of cubic) motor of 0.1 [kW] is displayed on the left example.

### 9.3 Basic type (DI/DO position)

The basic type amplifier operates according to the control input signals.

#### (1) Control input signals

In the monitor mode of the keypad panel, the control input signal on/off status can be checked.  
 The main circuit power input and control input/output power supply (+24 [V] DC) can be supplied.  
 CONT11 (+OT), CONT12 (-OT), and CONT13 (forced stop) are NC contact inputs.

Key operation	Indication (example)	Remark
		Example of test running mode display
		The MODE key selects a mode.
		Select the monitor mode.
		By the ^ key or key, select [ On012 ].
		Holding down the ENT key for at least 1 [s] allows to check the input signal on/off.

If a control input signal on CN1 turns on, the corresponding LED lights.  
 The input signal display [ On012 ] in the monitor mode is updated in real-time.

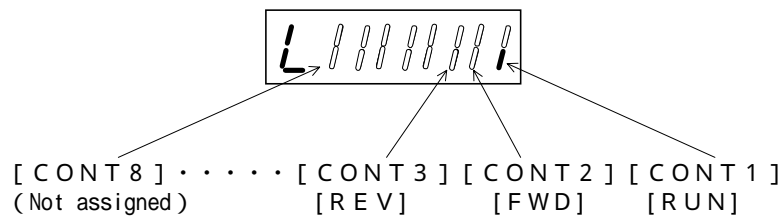

## (2) Manual operation

By turning on the CONT1 [RUN] of amplifier (as factory set), the motor can be rotated.

If output signals (PLC, etc.) to the amplifier are not inputted to the amplifier, check the +24 [V] DC power supply to CN1.

- (a) Supply power to the amplifier.
- (b) Make sure a voltage is outputted from the +24 [V] DC power supply.
- (c) Check the connection of forced stop signal (Beware of NC contact input.)
- (d) Turn on the run command [RUN] signal.

By the keypad panel of amplifier, make sure the LEDs light according to the run command.

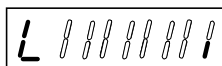

(e) On the keypad panel, the sequence mode recognized by the amplifier can be checked.

Key operation	Indication (example)	Remark
		Example of monitor mode display
		The MODE key selects a mode.
		Change the mode.
		Change the mode.
		Change the mode.
		Change the mode.
		By the  key or  key, select [ Sn001 ].
		Holding down the ENT key for at least 1 [s] causes a sequence display.
		Turning on [RUN] signal displays [ ==run ].

(f) The motor starts running by turning on the CONT7 [FWD] signal after turning on CONT12 [X1].

At factory setting, the motor speed is 100 [r/min] (basic para. 1 setting).

(g) Turning off the CONT7 [FWD] stops the motor whether CONT12 [X1] is on or not.

### (3) Positioning data

For test running, the motor is started upon setting the positioning data by which the motor output shaft makes one rotation.

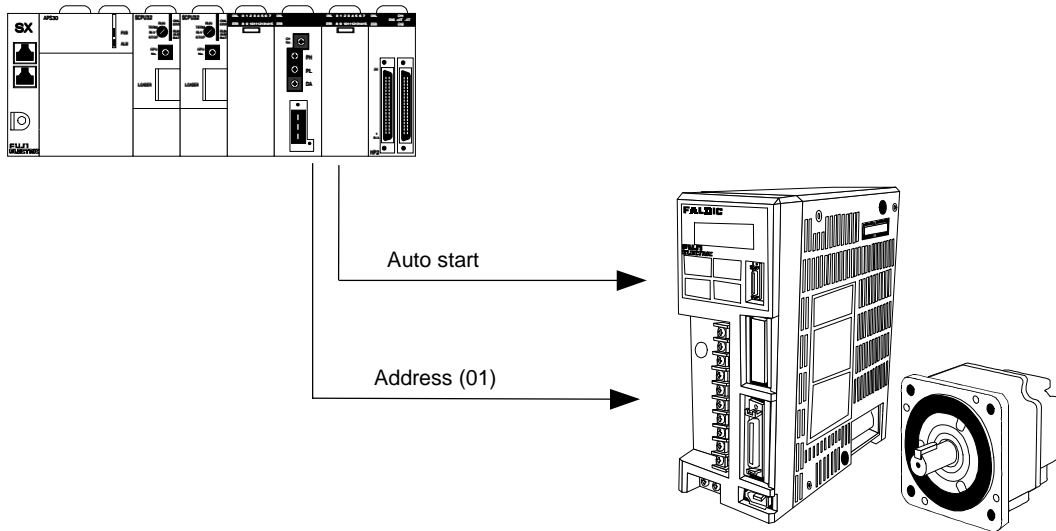

#### (a) Positioning data

The motor is factory set at  $(65536/8) = 8192$  pulses/revolution.

Set the following data at the positioning data No. 1.

#### Positioning data for test running

No.	Command method	Step mode	Stop position	Motor speed	M code	M code output
1	INC		81.92	10.00		
2	ABS					
3	ABS					
4	ABS					

#### Positioning data (stop position)



Speed data (motor speed)



Status (command method)



(b) Control input signal

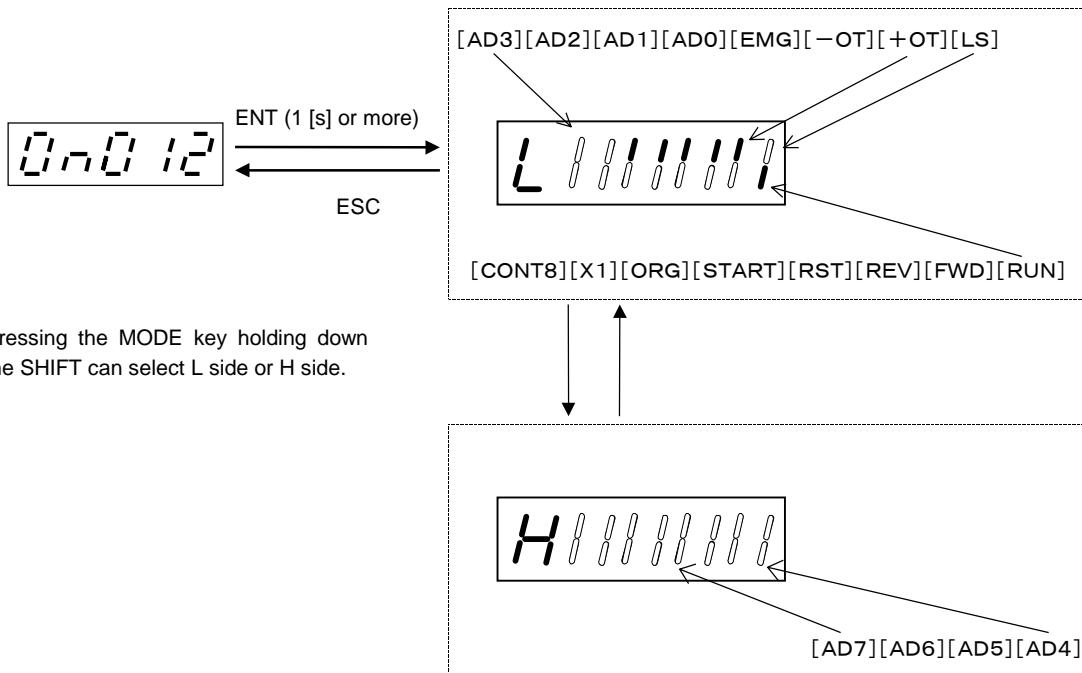

Make sure the control input signals are turned on/off the same way as the previous page.

At the ON edge of auto start [START] signal, the motor shaft makes one rotation.

Since the INC is designated for positioning data, each input of [START] execution causes one rotation.

#### 9.4 SX bus (SX bus direct connection)

The SX bus direct connection type amplifier operates according to the on/off status of IQ area.









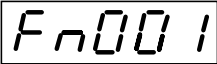

##### (1) Control input signal

At factory setting, no signals are allocated to CN1.

Test running can be made without connecting to CN1.

For safety purpose, allocate the following signals before usage. The forced stop (10), +OT (7), and -OT (8) are NC contact inputs, and require the control power +24 [V] DC.

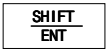
- Forced stop (10)
- +OT (7)
- -OT (8)
- Origin LS (6)

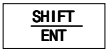
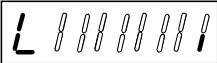
Key operation	Indication (example)	Remark
		Example of test running mode display
		The MODE key selects a mode.
		Select the monitor mode.
		By the  key or  key, select [  ].
		Holding down the ENT key for at least 1 [s] allows to check the input signal ON/OFF.

If a control input signal on CN1 turns on, the corresponding LED lights.

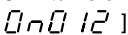
The input signal display [  ] in the monitor mode is updated in real-time.

## (2) Manual operation

By turning on the CONT6 [RUN] of IQ area (as factory set), the motor can be rotated.

For the station No., see 5.8 IQ area (SX bus). If the station number setting is 50, specify "%QX50. 15. 15" to CONT6. If a signal is allocated to CN1, check the +24 [V] DC power supply to CN1.

- (a) Supply power to the amplifier.
- (b) Make sure a voltage is outputted from the +24 [V] DC power supply.
- (c) Check the connection of forced stop signal (Beware of NC contact input.)
- (d) Turn on the run command [RUN] signal.

By the keypad panel of amplifier, make sure the LEDs light according to the run command.

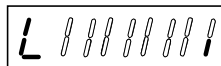

- (e) On the keypad panel, the sequence mode recognized by the amplifier can be checked.
- (f) The motor starts running by turning on the CONT7 [FWD] signal after turning on CONT12 [X1].  
At factory setting, the motor speed is 100 [r/min] (basic para. 1 setting).
- (g) Turning off the CONT7 [FWD] stops the motor whether CONT12 [X1] is on or not.

Key operation	Indication (example)	Remark
		Example of monitor mode display
		The MODE key selects a mode.
		Change the mode.
		Change the mode.
		Change the mode.
		Change the mode.
		By the  key or  key, select [  ].
		Holding down the ENT key for at least 1 [s] causes a sequence display.
		Turning on [RUN] signal displays [  ].

## (3) Immediate positioning

Positioning can be made by giving a position data to IQ area.  
For details of IQ area, see 5.8 IQ area.

• IQ area (at factory setting)

Address	15	14	13	12	11	10	9	8	7	6	5	4	3	2	1	0	
0	Current position, current deviation/basic para., system para., current position data/LS-Z phase pulse (Low order word PC Amplifier)																
1	Current position, current deviation/basic para., system para., current position data/LS-Z phase pulse (High order word PC Amplifier)																
2	Current speed/current speed data (Low order word PC ← Amplifier)																
3	Current speed/current speed data (High order word PC ← Amplifier)																
4	Current torque/current timer data (PC ← Amplifier)																
5	-					Alarm/current status					Current M code						
6	-					CSEL 2	CSEL 1	CSEL 0	Parameter current No./positioning data current No.								
7	RDY	PSET	CPU ready	ALM	Data error	Address error	-	-	-	-	-	-	-	-	Rewrite end	Read end	
8	Basic para./system para./position data (Low order word PC → Amplifier)																
9	Basic para./system para./position data (High order word PC → Amplifier)																
10	Speed command/speed command setting (Low order word PC → Amplifier)																
11	Speed command/speed command setting (High order word PC → Amplifier)																
12	Timer data setting (PC → Amplifier)																
13	-					Status setting					M code setting						
14	-					SEL2	SEL1	SEL0	Para. No. setting/Positioning data No. setting								
15	RUN	FWD	REV	RST	START	ORG	X1	VEL0	VEL1	ABS INC	-	-	-	-	Rewrite command	Read command	

### 9.5 T-link (T-link direct connection)

The T-link direct connection type amplifier operates according to the on/off status of WB area.







#### (1) Control input signal

At factory setting, no signals are allocated to CN1.

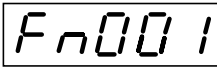
Test running can be made without connecting to CN1.

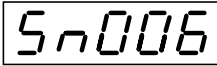
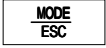
For safety purpose, allocate the following signals before usage. The forced stop (10), +OT (7), and -OT (8) are NC contact inputs, and require the control power +24 [V] DC.

- Forced stop (10)
- +OT (7)
- -OT (8)
- Origin LS (6)

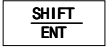
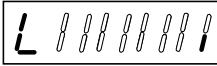
Key operation	Indication (example)	Remark
		Example of test running mode display
		The MODE key selects a mode.
		Select the monitor mode.
		By the    key or    key, select [ On012 ].
		Holding down the ENT key for at least 1 [s] allows to check the input signal on/off.

If a control input signal on CN1 turns on, the corresponding LED lights.

The input signal display [ On012 ] in the monitor mode is updated in real-time.

## (2) Manual operation

By turning on the bit 0 in word +4 [RUN] of WB area (as factory set), the motor can be rotated.

For the WB area, see 5.9 WB area. If the top address setting is 50, specify "B540" at bit 0 in word +4. If a signal is allocated to CN1, check the +24 [V] DC power supply to CN1.

- (a) Supply power to the amplifier.
- (b) Make sure a voltage is outputted from the +24 [V] DC power supply.
- (c) Check the connection of +OT, -OT, and forced stop signal (Beware of NC contact input.)
- (d) Turn on the run command [RUN] signal.

By the keypad panel of amplifier, make sure the LEDs light according to the run command.

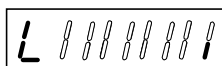

(e) On the keypad panel, the sequence mode recognized by the amplifier can be checked.

(f) The motor starts running by turning on the bit 2 in word +4 [FWD] signal after turning on bit A in word +4 [X1].

At factory setting, the motor speed is 100 [r/min] (basic para. 1 setting). Make sure that the current position indication changes in words +2, +3.

(g) Turning off the CONT7 [FWD] stops the motor whether CONT12 [X1] is on or not.

Key operation	Indication (example)	Remark
		Example of monitor mode display
		The MODE key selects a mode.
		Change the mode.
		Change the mode.
		Change the mode.
		Change the mode.
		By the  key or  key, select [  ].
		Holding down the ENT key for at least 1 [s] causes the sequence display.
		Turning on [RUN] signal displays [  ].

## (3) Immediate positioning

Positioning can be made by giving a position data to WB area.

For details of WB area, see 5.9 WB area.

· WB area (at factory setting)

Address	0	1	2	3	4	5	6	7	8	9	A	B	C	D	E	F	
+0	RDY	PSET	CPU ready	Alarm detect	Address error	+OT detect	-OT detect	LS detect	EMG detect	Data error	-	-	-	-	-	-	
+1	-	ALM4	ALM3	ALM2	ALM1	ALM0	Rewrite end	Read end	-								
+2	Read data (High order word										PC ← Amplifier)						
+3	Read data (Low order word										PC ← Amplifier)						
+4	RUN	START	FWD	REV	ORG	EMG	RST	VEL0	VEL1	ABS INC	X1	-	-	-	-	-	
+5	-	Read/rewrite data select					Rewrite command	Read command	Address No.								
+6	Rewrite data (High order word										PC → Amplifier)						
+7	Rewrite data (Low order word										PC → Amplifier)						

## 9.6 General-purpose communication (RS485 interface)

The general-purpose communication type amplifier operates according to the RS485 command.

### (1) Control input signal

At factory setting, such signals as the run command [RUN] and auto start [START] are allocated to CN1.

These signals can be executed by means of the RS485 command. If these signals are not necessary, change the setting of system para. 1 and 2 to "0", and turn off and on power.

The forced stop (10), +OT (7), and -OT (8) are NC contact inputs, and require the control power +24 [V] DC.



CN1 allocation

CN1		CN1	
Terminal symbol	Initial value	Terminal symbol	Initial value
CONT1	Run command [RUN]	OUT1	Ready [RDY]
CONT2	Auto start [START]	OUT2	Positioning end [PSET]
CONT3	Origin LS [LS]	OUT3	-
CONT4	+OT	OUT4	-
CONT5	-OT		
CONT6	Forced stop [EMG]		
CONT7	-		
CONT8	-		

CN1 pin layout

26	M 5	25	P 5	13	M 5	12	C B
24	MON 2	23	* C B	11	C A	10	F Z
22	* C A	21	B A T +	9	F B	8	F A
20	OUT 4	19	OUT 3	7	OUT 2	6	OUT 1
18	CONT 8	17	CONT 7	5	CONT 4	4	CONT 3
16	CONT 6	15	CONT 5	3	CONT 2	2	CONT 1
14	M 2 4	1	P 2 4				

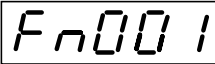
CONT1 to CONT8 can be monitored by the following step.

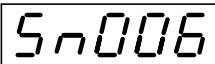
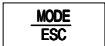
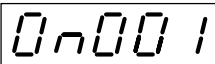
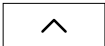
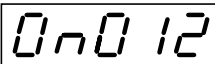
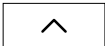
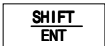
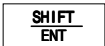
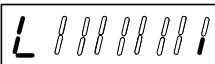
Key operation	Indication (example)	Remark
		Example of test running mode display
		The MODE key selects a mode.
		Select the monitor mode.
		By the  key or  key, select [ 0n012 ].
		Holding down the ENT key for at least 1 [s] allows to check the input signal on/off.

If a control input signal on CN1 turns on, the corresponding LED lights.

The input signal display [ 0n012 ] in the monitor mode is updated in real-time.

## (2) Manual operation

By turning on the CONT1 (run command) terminal of CN1, the motor can be rotated.

When DATA (1) : 01H is transmitted with CM: 34H and SCM: 33H, the motor starts running at the speed of basic para. 1 setting.

When CM: 34H and SCM: 36H are transmitted, the motor stops.

If a signal is allocated to CN1, check the +24 [V] DC power supply to CN1.

- (a) Supply power to the amplifier.
- (b) Make sure a voltage is outputted from the +24 [V] DC power supply.
- (c) Check the connection of +OT, -OT, and forced stop signal (Beware of NC contact input.)
- (d) Turn on the run command [RUN] signal.

By the keypad panel of amplifier, make sure the LEDs light according to the run command.

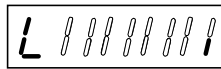

- (e) On the keypad panel, the sequence mode recognized by the amplifier can be checked.

Key operation	Indication (example)	Remark
		Example of monitor mode display
		The MODE key selects a mode.
		Change the mode.
		Change the mode.
		Change the mode.
		Change the mode.
		By the  key or  key, select [  ].
		Holding down the ENT key for at least 1 [s] causes the sequence display.
		Turning on [RUN] signal displays [  ].

## (3) Auto start (immediate value)

Positioning can be made by giving a position data by means of the RS485 command.

For details of the message, see 5.10 General communication.

## 10. INSPECTION AND MAINTENANCE

### 10.1 Inspection

#### (1) Before inspection

Because the amplifier is composed of electronic components, usually inspection is not necessary.

Because the motor is a synchronous type (brushless) motor, the motor does not have the part to inspect usually.

Both the amplifier and motor are maintenance-free. However, perform periodic inspection to prevent accidents beforehand and ensure the reliability of equipment.



#### DANGER

**Prior to inspection, turn off power and wait for at least five minutes. Otherwise, there is a risk of electric shock. Do not touch the amplifier when the commercial power is supplied. Otherwise, there is a risk of electric shock.**

#### (2) Inspection items

Device	Inapplicable item
Motor	Abnormal vibration (on motor-shaft and bearing-housings, etc.) Direct exposure to water, steam or oil Misalignment of mechanical coupling at shaft extension
Amplifier	Loose screws of terminal block (board) and fastening parts Excessive accumulation of dust Nasty smell, damage due to heat, external deformation, cable-wire discontinuation, etc.

Ensure that the "CHARGE" LED is extinguished (goes out) on keypad panel, before the checking of electrical wirings.



#### CAUTION

**Withstand voltage and insulation test with megger and connection test of PC-board and terminals of amplifier must not be conducted. Otherwise, there is a risk of damage to amplifier or encoder built in the motor.**

### 10.2 Memory backup

#### (1) Memory backup

An electrically rewritable EEPROM is used for retaining the following items after turning off power supply.

- (i) Basic para. and system para.
- (ii) Positioning data (RYS-L type amplifier only)
- (iii) Alarm detection history

Each area can be initialized by turning off the run command [RUN] of the amplifier (while motor is de-energized).

##### (a) Initialization of parameter

To initialize, select the para. initialization [ *F n006* ] in the test running mode and press the ENT key.

Notice : After the initialization, be sure to turn on power again.

*F n006*

The initialization is not allowed if rewrite is inhibited by system para. 94.

*PARt*

The initialization is impossible while the motor is energized with the [RUN] signal on.

##### (b) Initialization of positioning data (RYS-L type amplifier only)

To initialize, select the positioning data initialization [ *F n007* ] in the test running mode and press the ENT key.

Notice : After the initialization, be sure to turn on power again.

*F n007*

The initialization is not allowed if rewrite is inhibited by system para. 95.

*PorT*

The initialization is impossible while the motor is energized with the [RUN] signal on.

(c) Initialization of alarm detection history

The alarm detection history is held at all times. It can be initialized by the history initialization [ *F n 0 0 5* ] in the test running mode of the keypad panel.

**(2) Copying the memory**

Use of a handy-loader or PC-loader can copy the setting contents of amplifier to the loader or, reverse, the loader contents can be transferred to the amplifier.

If you have no technical documents for operation of handy-loader or PC-loader, contact us.

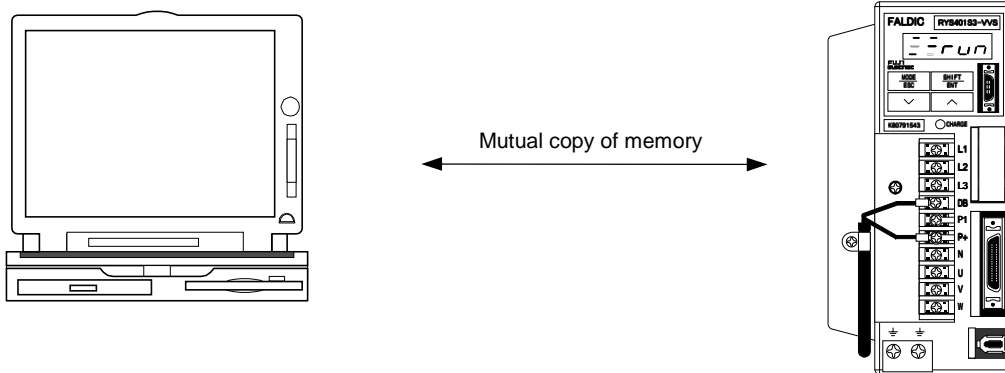

**(3) Saving the setting contents into RAM**

The EEPROM reaches its end of expected-service life after approx. 100,000 operations.

If basic para. and positioning data are saved in RAM, rewriting is available any number of times.

For saving in RAM, refer to 6.3 (6).

Para. and positioning data saved in RAM can be rewritten any number of times.

Turning on power selects default values.

**10.3 Fault display**

The fault diagnosis is explained in three sections below.

- (1) Initial status
- (2) When error (failure) is not displayed
- (3) Faults with alarm indication

**(1) Initial status**

After turning on commercial power for the amplifier, some of 7 segments on the keypad panel lit (light up). The "CHARGE" LED lights on the keypad panel.

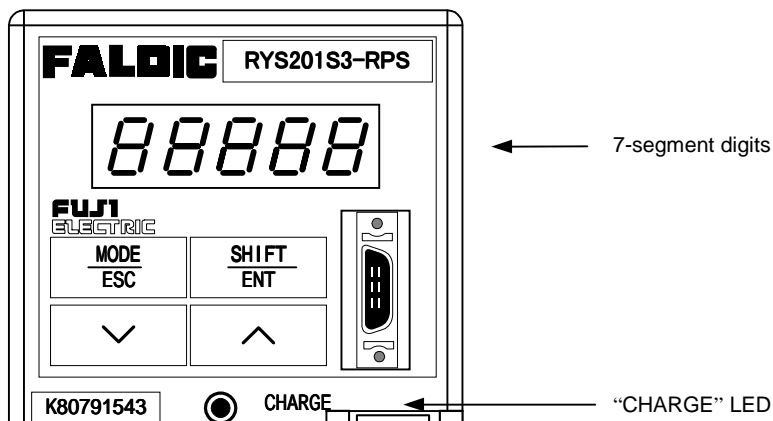

If turning on power displays nothing, contact us.

Supplying only the control power lights the display.

**(2) When error (failure) is not displayed**

The following exemplifies checkup procedure. As required, contact us.

**(a) Motor does not rotate**

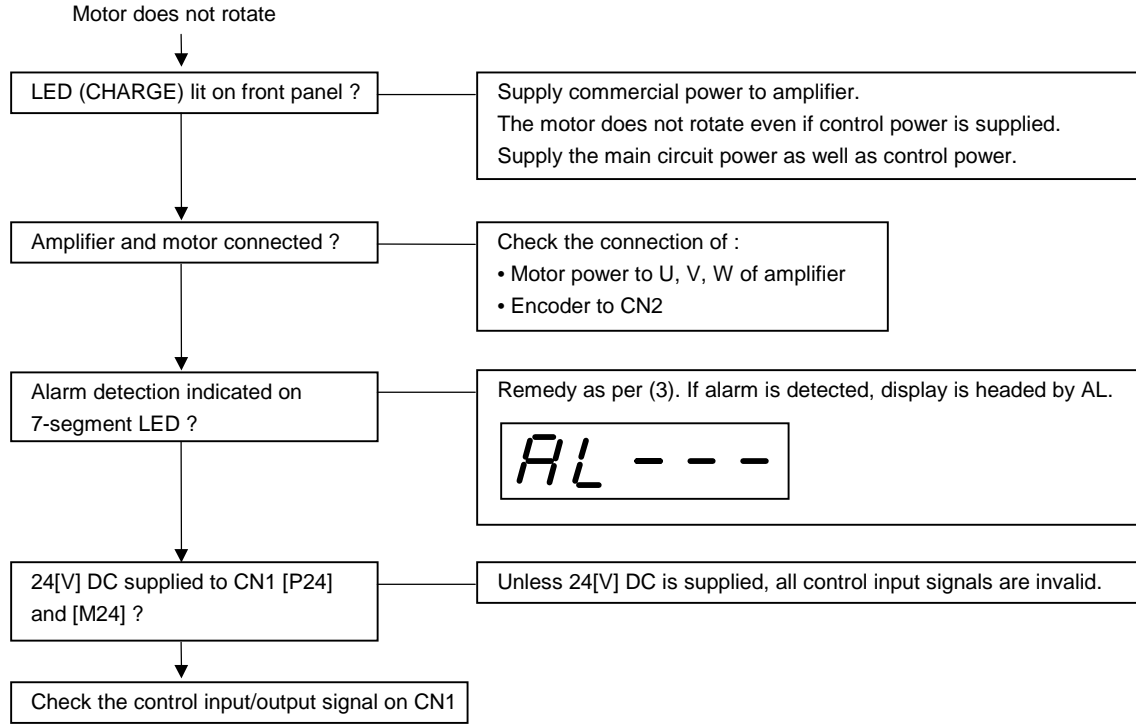

(i) Sequence display

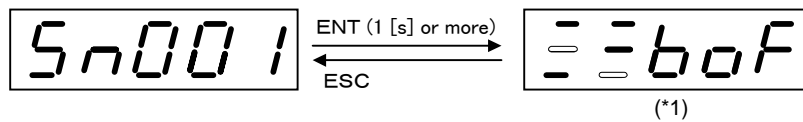

(\*1) Displays the current status

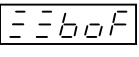
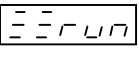
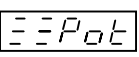
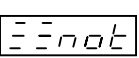
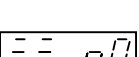
Indication	Description	Check and remedy
	In base-off condition, the motor has no driving force and in free-run status.	<ul style="list-style-type: none"> <li>• Turn on the run command [RUN].</li> <li>• Turn off the free-run command [BX].</li> </ul>
	The motor can rotate.	Proceed to (ii).
	The amplifier has detected an overtravel signal in positive direction and stops.	Reset [+OT] by on.
	The amplifier has detected an overtravel signal in negative direction and stops.	Reset [-OT] by on.
	The amplifier has received a forced stop [EMG] signal and stops with the speed zero signal on.	Reset [EMG] by on.

(ii) Sub-mode display

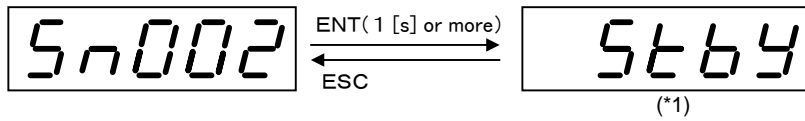

(\*) Displays the current status

Indication	Description	Check and remedy
	In base-off condition, the motor has no driving force and in free-run status.	Turn on the run command [RUN]. Turn off the free-run command [BX].
	The motor can rotate and is waiting the run command.	Manual forward [FWD] may not be valid.
	The motor can rotate and is executing manual feed.	The motor is already rotating. Increase the analog input voltage or multistep speed setting.
	The motor can rotate and the pulse train input is valid.	The pulse train may not be input or the pulse train signal form may be different.
	The motor can rotate and is executing positioning operation.	Increase the speed data.
	The motor can rotate and is executing origin return.	Increase the origin creep speed.
	The motor can rotate and is executing interrupt positioning.	-
	The amplifier is executing deviation clear.	Invalidate the deviation clear signal.
	The motor can rotate and is measuring the brake timing.	-
	The motor is stopping with positioning cancel signal.	Invalidate the positioning cancel signal.
	The amplifier has detected an overtravel signal in positive direction and stops.	Reset [+OT] by on.
	The amplifier has detected an overtravel signal in negative direction and stops.	Reset [-OT] by on.

**(b) Motor hunting rotation (motor shaft rotates forward/reverse repeatedly)**

The amplifier which incorporates a real-time turning function estimates the mechanical equipment system at all times. For the amplifier, the real-time turning function is factory validated.

The real-time turning function is valid for almost all the mechanical equipment systems except some examples. If it does not work, contact us.

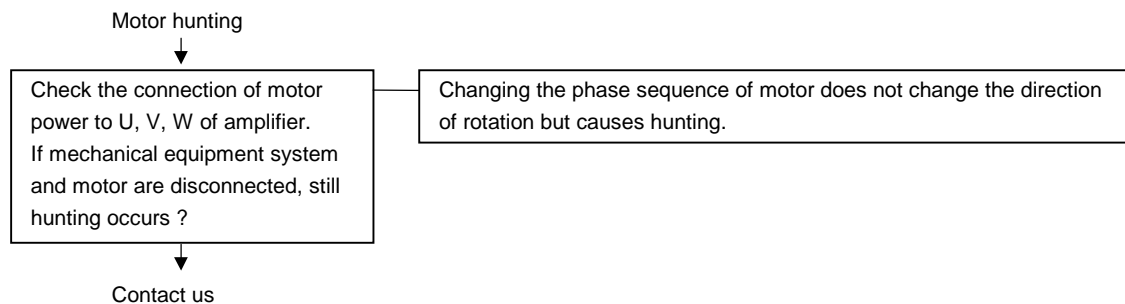

**(c) Positioning accuracy is poor**

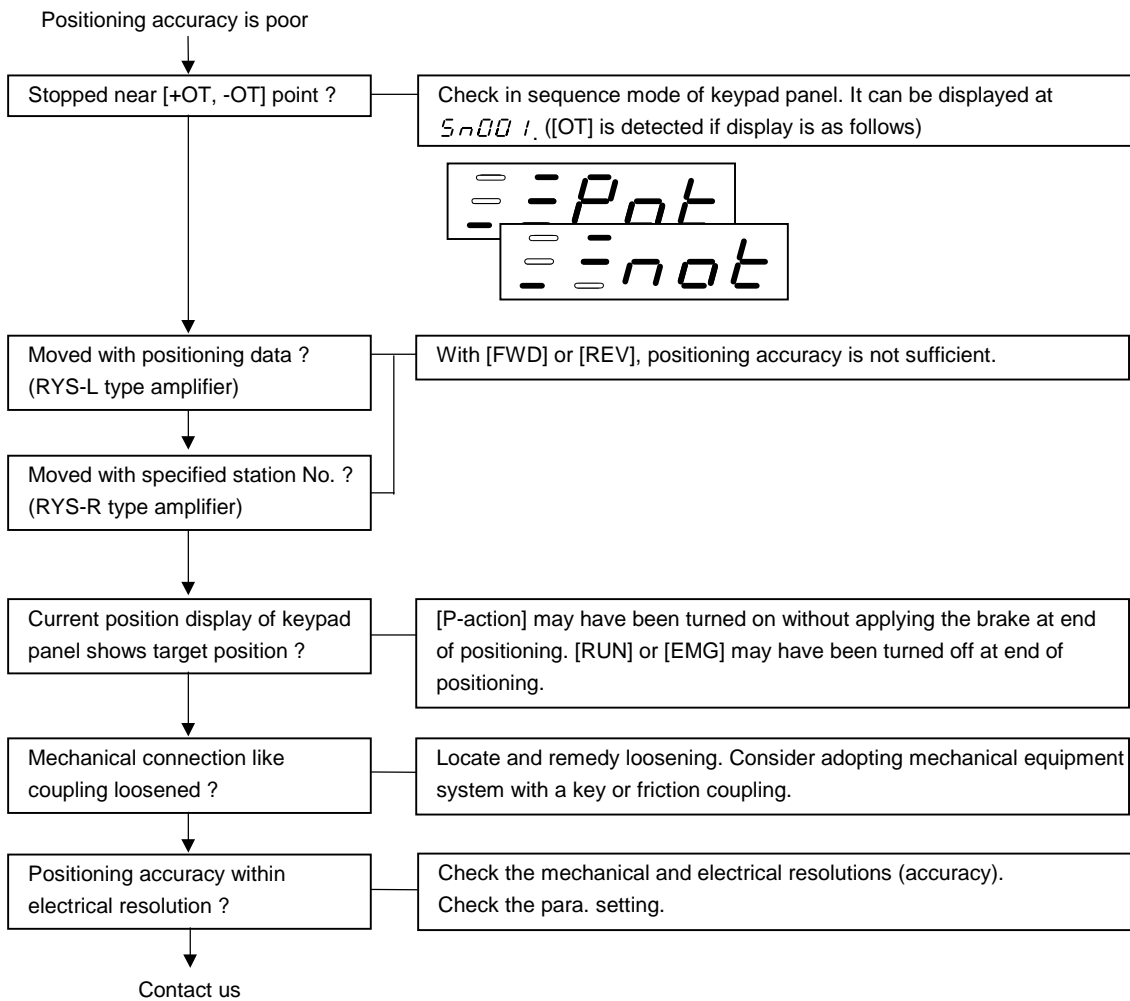

**(d) Origin return action is faulty**

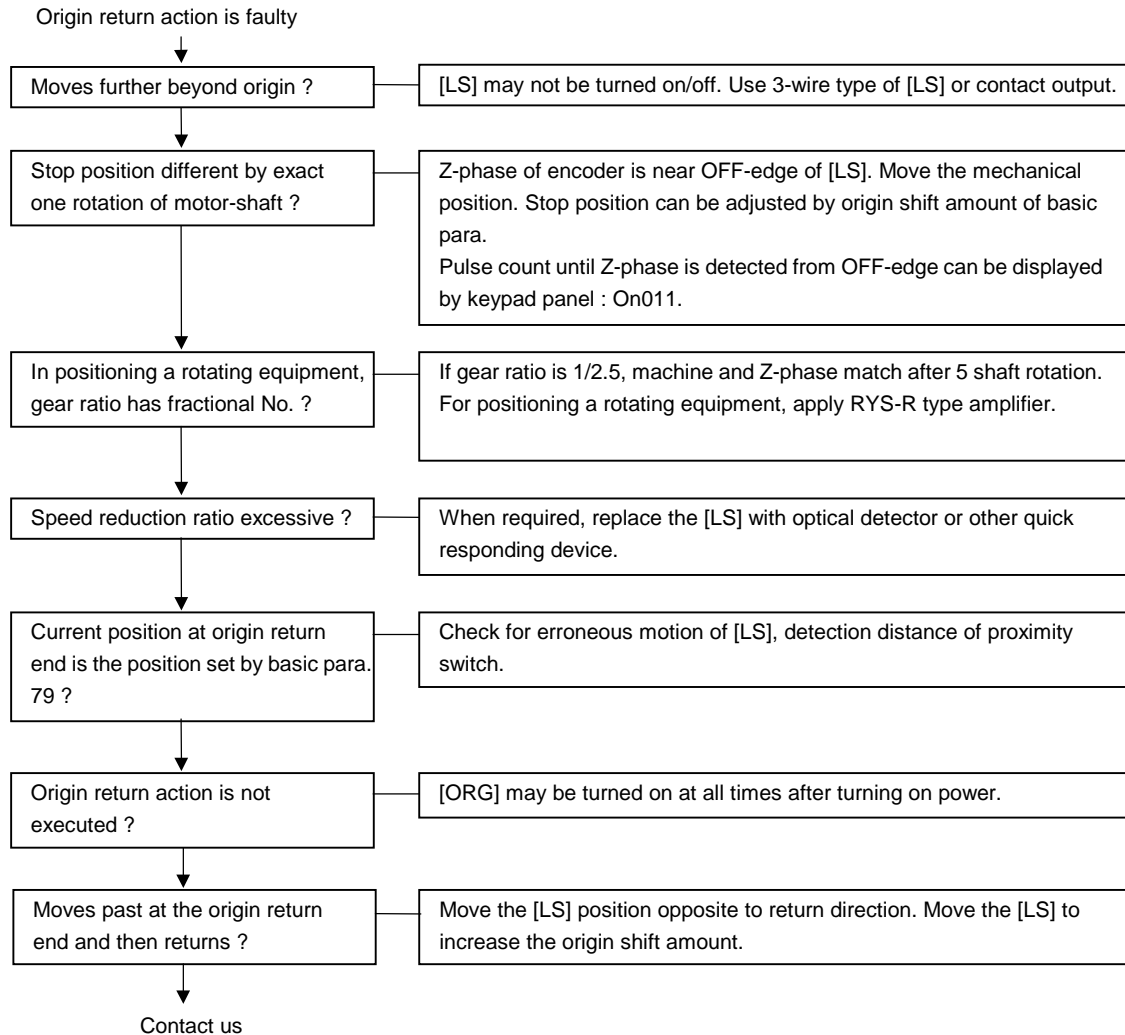

### (3) Faults with alarm indication

If an alarm is detected, the detected contents are displayed on the keypad panel of amplifier.

If multiple alarms are detected simultaneously, alarm indication is made in accordance with the priority order given below.

Priority order	Display	Description
1	AL SE	System error
2	AL OC	Overcurrent, output overcurrent
3	AL OS	Overspeed
4	AL LV	Low voltage, undervoltage
5	AL HV	High voltage, overvoltage
6	AL EE	Encoder trouble
7	AL CE	Circuit trouble, amplifier trouble
8	AL dE	Data error, memory error
9	AL Fb	Fuse brown
10	AL CE	Combination error
11	AL rH2	Resistor heat 2
12	AL EC	Encoder communication error
13	AL CEE	Cont (control signal) error
14	AL OL	Over load, motor overheat
15	AL rH	Resistor heat, braking (DB) resistor overheat
16	AL OF	Overflow, deviation excessive
17	AL AH	Amp heat, amplifier overheat
18	AL EH	Encoder heat, encoder overheat
19	AL AL	Absolute data lost
20	AL AF	Absolute data overflow
21	AL tE	Terminal error
22	AL ---	(non)

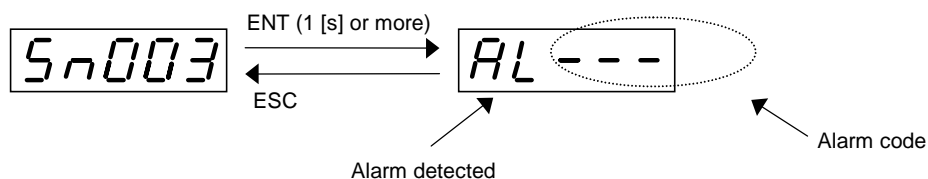

Remark : An alarm is automatically displayed if detected.

If, at a displayed status, the alarm detection is reset by a control input signal, the initial screen (system para. 89 setting) appears.

The alarm detection can be reset in the test running mode [ F n 0 0 4 ] also.

Holding down the key and key simultaneously for at least 1 [s] at a status where an alarm detection is displayed resets the alarm detection.

**(a) Overload, motor overheat**

- Keypad panel display

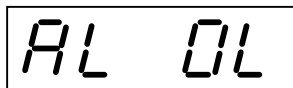

- Contents of alarm

The rms (root-mean-square) value of torque (command value) of motor exceeded the value allowed to the motor (detected by electronic thermal relay built-in amplifier).

- Cause, check and remedy

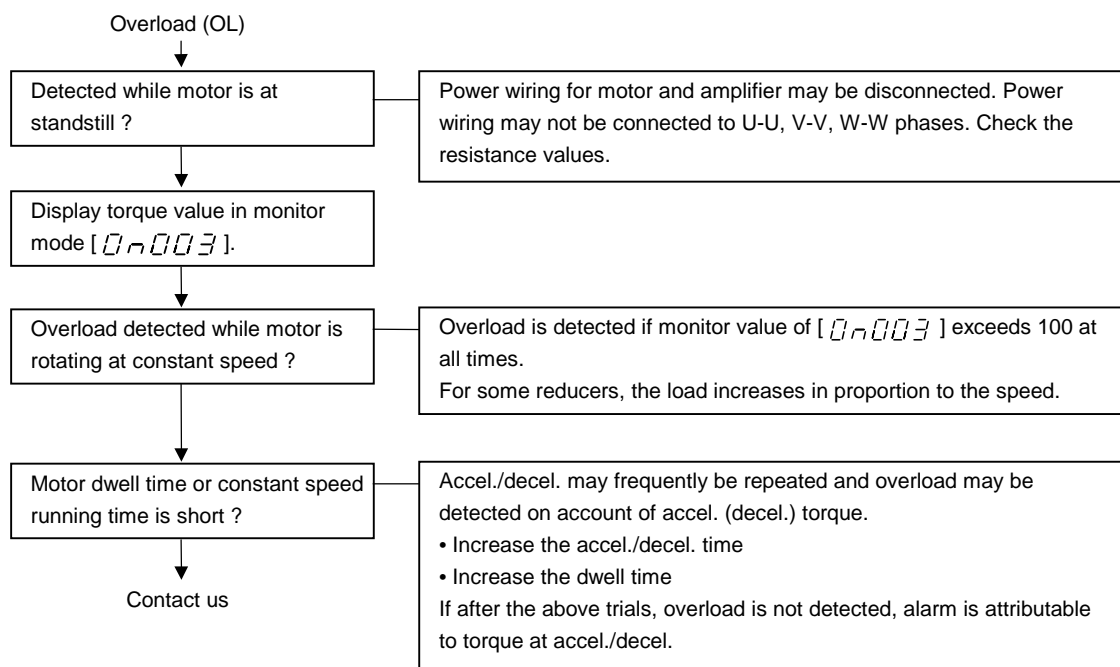

**(b) Absolute data lost**

- Keypad panel display

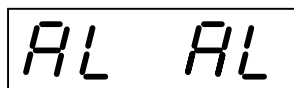

- Contents of alarm

Absolute value data of the 16-bit serial encoder built in GYC/GYS type motor are lost.

- Cause, check and remedy

This alarm is detected only when ABS (absolute system) is selected by setting of system para. 99.

Use an absolute system upon presetting the current position. This alarm detection cannot be reset by alarm reset [RST] signal.

(i) Mount a battery (WSB-S type) on the amplifier or supply power to the control input/output terminal on CN1.

(ii) Connect the encoder wiring from CN2 to the encoder wires of motor.

The current position information is destroyed if approx. 1 [h] elapses at a status where the encoder wiring is not connected.

(iii) Preset the current position in the test running mode [Fn003].

Executing the position preset simultaneously resets the alarm detection, with the current position as set value of basic para. 80.

**(c) Absolute data overflow**

- Keypad panel display



- Contents of alarm

The shaft extension of GYC/GYS type motor rotated beyond the range of - 32768 to 0 to + 32768 revolutions.

- Cause, check and remedy

On an absolute system, the rotational quantity of the motor shaft extension is limited.

For the alarm resetting method, see (b) above.

**(d) Combination error**

- Keypad panel display

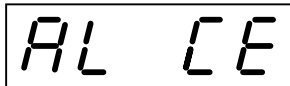

- Contents of alarm

The combination of connected amplifier and motor is not correct.

- Cause, check and remedy

Upon turning on power, the amplifier automatically recognizes the motor.

Use amplifier and motor as a specified pair of model types

The amplifier usually drives a motor of the same frame size as the amplifier. The amplifier can also drive a motor that has one larger or smaller frame size. However, the combination with two frame size larger or smaller motor causes a combination error.

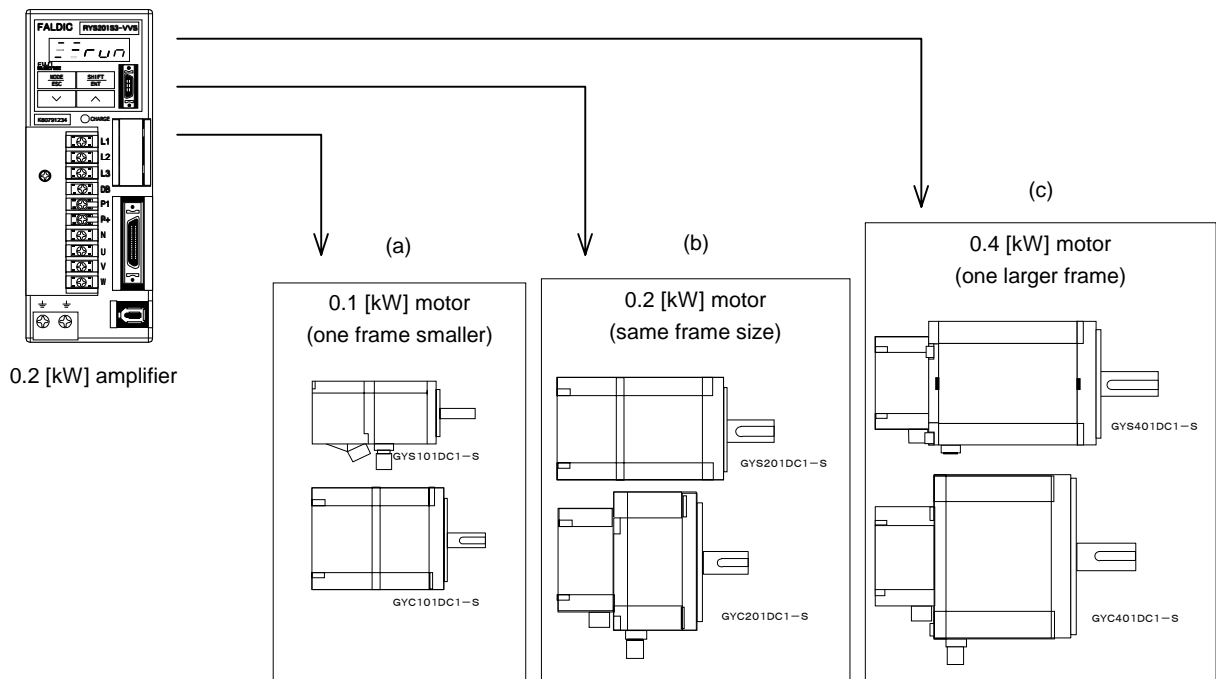

- (a) : The rated torque is the one for one frame smaller motor.
- (b) : The rated torque is the one for the same frame size motor.
- (c) : The rated torque is the same as where the same frame size motor is used.

**(e) Cont (control signal) error**

- Keypad panel display

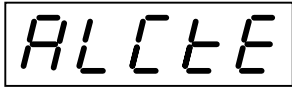

- Contents of alarm

One and the same signal is allocated to several control input signal (CONTn) terminals on CN1 of amplifier.

- Cause, check and remedy

Since the same signal cannot be allocated to several terminals, any one setting should be selected. But, forced stop (10), free-run (54), external fault input (34) and "not assigned" (0) can be allocated to several terminals. The same signal can be allocated to several control output terminals.

Remark : The cont error does not occur in case of overlap setting of the CONT always valid 1, 2 (system para. 87, 88) and the system para. A signal set at the CONT always valid is valid at all times.

Interrupt input (49) is valid to control input terminal of hardware only.

**(f) Low voltage, undervoltage**

- Keypad panel display

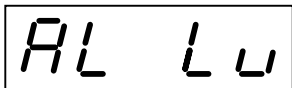

- Contents of alarm

The voltage supplied to the amplifier is below the minimum specified level.

- Cause, check and remedy

The supply voltage may have dropped on account of momentary failure, etc. or the power supply capacity may be poor.

Remark : The detection of undervoltage can be invalidated by setting of system para. 85 if the power supply condition is not good.

In this case, if free-run is selected by setting of system para. 84, the running can be continued at momentary power failure.

**(g) High voltage, overvoltage**

- Keypad panel display

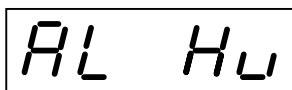

- Contents of alarm

The DC intermediate voltage in the amplifier is higher than the upper limit.

- Cause, check and remedy

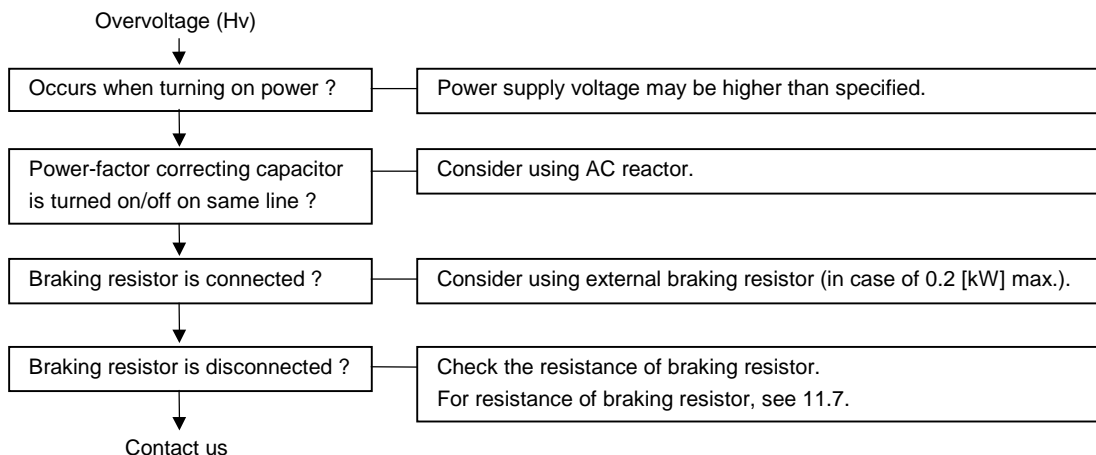

**(h) Amp heat, amplifier overheat**

- Keypad panel display



- Contents of alarm

The temperature of cooling-fins of the amplifier is above 100°C.

- Cause, check and remedy

The ambient temperature for the amplifier should be below +55°C. The lifetime of large-capacity capacitor in the amplifier greatly varies depending on the ambient temperature.

**In case the alarm was detected below 55°C, contact us.**

**(i) Encoder communication error**

- Keypad panel display

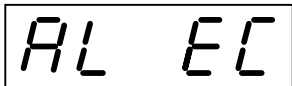

- Contents of alarm

The communication is not made between 16-bit serial encoder and amplifier.

- Cause, check and remedy

The encoder wiring may be detached or disconnected.

The serial communication is performed at 4 [Mbps] of data rate. Do not extend the wiring by connecting several short cables.

Connect the encoder by optional cable or specified cables.

The encoder wiring has about 5 [V] of voltage amplitude. Do not install it in a location where a strong electric or magnetic field exists.

**(j) Resistor heat, braking (DB) resistor overheat**

- Keypad panel display

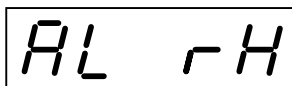

- Contents of alarm

The heating power of the braking resistor of amplifier exceeded a specified value.

- Cause, check and remedy

If an alarm is detected immediately after turning on power, the power supply voltage may be higher than specified.

If detected while running, the frequency of braking operation may be high, and the braking resistor may overheat. In such a case,

- use an external braking resistor,
- prolong the accel./decel. time. or
- raise the reduction speed ratio, if possible.

**(k) Overflow, deviation excessive**

- Keypad panel display



- Contents of alarm

Deviation amount (difference between the current command position and current feedback position) exceeded the set value of basic para. 54.

- Cause, check and remedy

The initial set value of basic para. 54 is 10000 (x 100) [pulse].

If the difference between the current command position and current feedback position exceeds 1000000 [pulse], an alarm is detected.

Under normal operating conditions, the deviation amount increases in proportion to the motor speed.

If an alarm is detected when rotating the motor by turning on the [RUN], the motor power wiring phases U, V, W may not be connected to the corresponding terminals (U, V, W) of the amplifier.

The set value of basic para. 54 need not be decreased.

The deviation amount can be reduced by setting the feed forward gain of basic para. 40 to near 1.000.

**(l) Other protection functions**

Under normal operating conditions, alarms other than the above mentioned are seldom detected.

If the following alarms appeared, contact us.

**(i) Encoder heat, encoder overheat**

- Keypad panel display

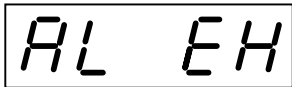

- Contents of alarm

The temperature of 16-bit serial encoder exceeded a specified value.

- Cause, check and remedy

The ambient temperature for the motor should be 40°C max.

If an alarm appeared before running such as immediately after turning on power, contact us.

**(ii) Resistor heat 2**

- Keypad panel display

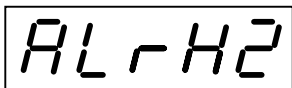

- Contents of alarm

The regenerative power processing transistor mounted on the amplifier overheats.

- Cause, check and remedy

The ambient temperature of amplifier should be 55°C max.

If an alarm appeared before running such as immediately after turning on power, contact us.

**(iii) Data error, memory error**

- Keypad panel display



- Contents of alarm  
Contents of the non-volatile storage memory mounted on the amplifier are destroyed.

- Cause, check and remedy  
If an alarm appeared immediately after turning on power, contact us.

**(iv) Circuit trouble, amplifier trouble**

- Keypad panel display

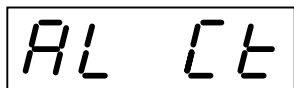

- Contents of alarm  
The control power supply circuit mounted on the amplifier is abnormal.

- Cause, check and remedy  
If an alarm appeared immediately after turning on power, contact us.

**(v) Encoder trouble**

- Keypad panel display

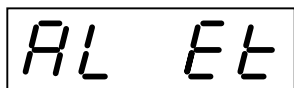

- Contents of alarm  
The 16-bit serial encoder attached to the motor may be broken.

- Cause, check and remedy  
If an alarm appeared immediately after turning on power, contact us.

**(vi) Overcurrent, output overcurrent**

- Keypad panel display

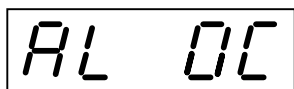

- Contents of alarm  
The output current from the amplifier to the motor exceeded a specified value.

- Cause, check and remedy  
The power wiring to the motor may be short-circuited or grounded.  
As a general rule, minimum insulation resistance between motor terminals and grounding (earth) terminal (symbol "E" or "⏏") is about 1 [MΩ].  
The motor winding resistance value between each phase is as same.

**(vii) Overspeed**

- Keypad panel display



- Contents of alarm  
The motor speed has exceeded 1.1 times of the max. speed.
- Cause, check and remedy  
At acceleration, overshooting may have occurred.  
Check the speed waveform at acceleration with a PC loader.

**(viii) Fuse brown**

- Keypad panel display

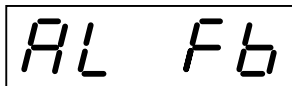

- Contents of alarm  
Voltage was generated at both ends of the fuse in the amplifier main circuit (2 [kW] and above).
- Cause, check and remedy  
The main circuit fuse is for preventing the secondary accident such as fire. The fuse cannot be replaced. Do not turn on power again, and contact us.

**10.4 Items to inquire when faulty**

If an alarm appeared, remedy it referring to 9.3.  
When contacting us, specify the following items.

- (a) Data on nameplate : Type, serial equipment No.
- (b) Device configuration : Example, type of external braking resistor etc.
- (c) Outline of mechanical equipment system driven by motor : Example, ball-screw feed, vertical drive, reduction speed ratio 1/2
- (d) Fault contents
  - (i) Running duration (years)
  - (ii) Alarm occurrence frequency, conditions : Example : when a certain device operates, the motor stops
  - (iii) Alarm display contents
  - (iv) Whether reproducible ?
  - (v) While accelerating, rotating at constant speed or decelerating ?
  - (vi) Whether different between forward and reverse rotation of motor ?
  - (vii) Whether at particular conditions ? : Example : when [RUN] signal has been turned on ?  
when advancing mechanical-table has come to a particular position ?
  - (viii) Whether trouble persists even after replacing the machine or amplifier with one having the same specification ?

## 10.5 Other information

### (1) Operating conditions : See 3. INSTALLATION.

#### (a) Power-on

The amplifier can be energized continuously.



#### **DANGER**

**Do not touch the amplifier when the commercial power is supplied. Otherwise, there is a risk of electric shock.**

#### (b) Specifications : See 2. SPECIFICATIONS.

GYC and GYS type motors are of continuous rating.

#### (c) Operation

Do not repeatedly turn on and off the commercial power supply to start and stop the motor.

It may affect the devices inside the amplifier.

#### (d) Radio noise : See 3.2 (1) (b) (iv) and 10.4.

Radio noise preventive measures are not implemented to the amplifier and motor as general industrial equipment. Therefore, following devices may receive noise:

- AM radios near the amplifier or motor
- Wired broadcast, etc. near the wiring
- Measuring instruments or household appliances

### (2) Expected-service-life

#### (a) Motor

The motor bearings should be replaced with new ones, when required. If the bearings produce unusual noise, replace bearings.

The motor incorporates (built-in) encoder, etc. Therefore, inquire us for how to replace the bearings.

#### (b) Cooling fan motor built in the amplifier

The expected-service-life of the fan will be approx. 20,000 [h].

Contact us when a replacement with new one is required.

#### (c) Brake built in the motor

The expected-service-life will be approx. 20,000 operations at rated torque.

#### (d) Capacitor built in the amplifier

The amplifier incorporates large capacitors. Contact us when a replacement with new one is required.

# 11. PERIPHERAL DEVICES

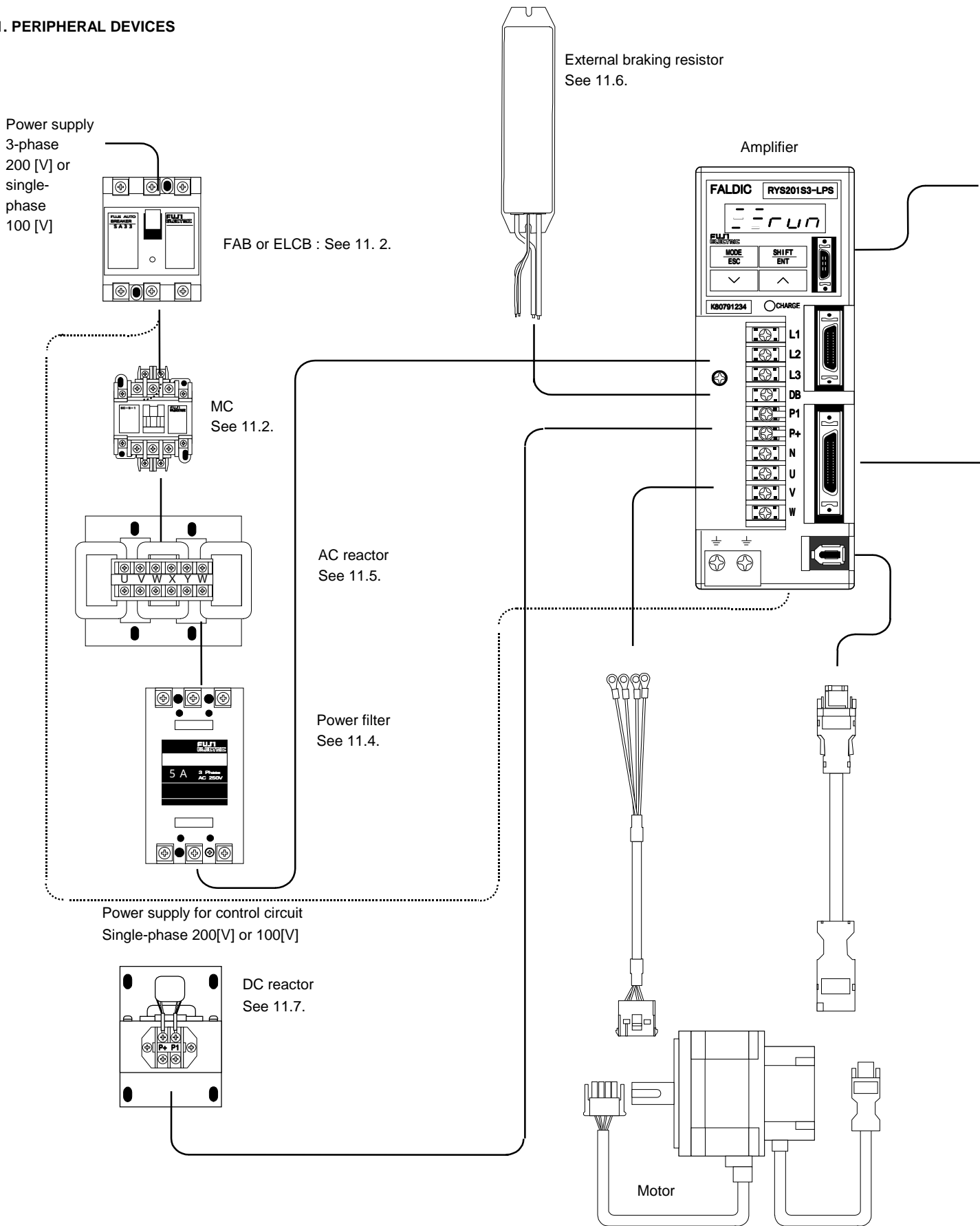

Example : Actual machines may differ in details.

Personal computer loader

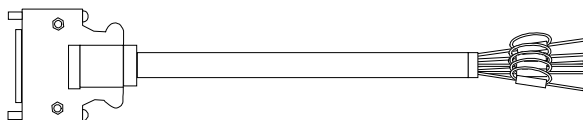
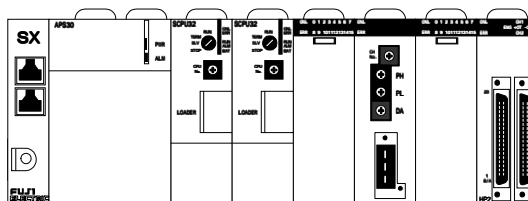
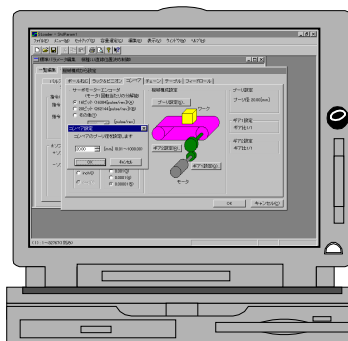

Optional cables  
See 11.8.

Programmable logic controller (PLC)  
MICREX-SX  
MICREX-F  
FREX-PC

### 11.1 Cables

Power supply and control circuit cables in the internal of the control panels are as follows :

#### (1) Power supply and motor input cables

(a) Cable size

Input voltage class		[V]	100	200		
Amplifier output		[kW]	0.05 to 0.2	0.03 to 0.4	0.75 to 1.5	2, 3, 4, 5
Amplifier type		RYS S3-	6			
			500 to 201	300 to 401	751 to 152	202, 302, 402, 502
Conductor sectional area of cable [mm <sup>2</sup> ]	Power supply, motor input, ground (earth)		1.25		2	3.5, 5.5
	Brake		1.25			
	Power supply for control		0.75			

(b) Cable type

- (i) 600 [V] class, poly-vinyl insulated cable (JIS C 3307) or
- (ii) Poly-vinyl insulated cable "KIV" (JIS C 3316) or
- (iii) 600 [V] class, cross-link polyethylene insulated cable "FSCL" (JCS 360) or equivalent

#### (2) Control input/output cables for CN1 : + 24 [V], 50 [mA] max.

(a) Size of twisted-pair shielded cable, AWG No.26

Amplifier type	CN1 for VVS, LPS, RPS	CN3 for LPS, RPS	CN1 for others
Cable	18-core	10-core	13-core

(b) Cable type

"XEBV" or "XEWV" (The Furukawa Electric Co. , Ltd.) or equivalent

#### (3) Host interface for CN3

- (a) Digital input/output and analog signal cable : Same as (2) above.
- (b) T-link, JPCN-1 and SX bus : Specified cables should be applied.

#### (4) Encoder cables for CN2 (4 [Mbps] serial communication)

Cross-link polyethylene insulated, poly-vinyl sheath cables RMCV-SV type :

Wiring length within	Cable size and pair, core quantities ( * )
10 [m]	AWG No.25 / 4-pair and AWG No.23 / 2-core
50 [m]	AWG No.25 / 4-pair and AWG No.17 / 2-core

or optional cable : See 11.8.

( \* ) AWG : See "Remark" of 4.3 (2) (d).

### 11.2 Auto circuit breaker (FAB, MCCB), earth leakage circuit breaker (ELCB) and magnetic contactor (MC) : Recommended Fuji's type

FAB or ELCB is installed on the power supply side for turning power supply and promptly cutting off a fault current such as short-circuit current. MC is used when amplifiers are disconnected from the power supply with an external signal or in the case of power on/off from remote operation panels.

The types are applicable to the power supply capacity up to 500 [kVA], specified diameter cable with the wiring length within 20 [m] is used, and on/off of the primary side of one amplifier is performed. Connect an AC reactor if the power supply capacity exceeds 500 [kVA].

(i) For 200 [V] class input voltage of amplifier

Amplifier output		[kW]		0.03 to 0.1	0.2	0.4	0.75 to 1.5	2	3	4, 5	
Amplifier type		RYS	S3-	300 to 101	201	401	751 to 152	202	302	402, 502	
Fuji's Recommended type	For each amplifier	FAB	type SA	33B/3	33B/5	33B/10	53B/15	33B/30	33B/40	33B/50	
				current [A]	3	5	10	15	30	40	50
	ELCB type		EG	33B/3	33B/5	33B/10	53B/15	33B/30	33B/40	33B/50	
MC type		SC-		5-1(19A)					1N (26A)		2N (35A)

(ii) For 100 [V] class input voltage of amplifier

Amplifier output		[kW]		0.05	0.1	0.2
Amplifier type		RYS	S3- 6	500	101	201
Fuji's Recommended type	For each amplifier	FAB	type SA	33B/3	33B/5	33B/10
				current [A]	3	5
	ELCB type		EG	33B/3	33B/5	33B/10
MC type		SC-		5-1(19A)		

### 11.3 Surge suppressor (surge killer)

Shown below are recommended surge suppressors (for 250 [V] AC or less ) to be installed on peripheral devices (magnetic contactor, solenoid, brake, etc. ) of amplifier.

DC equipment should be equipped with a diode for surge voltage suppression.

[unit : mm]

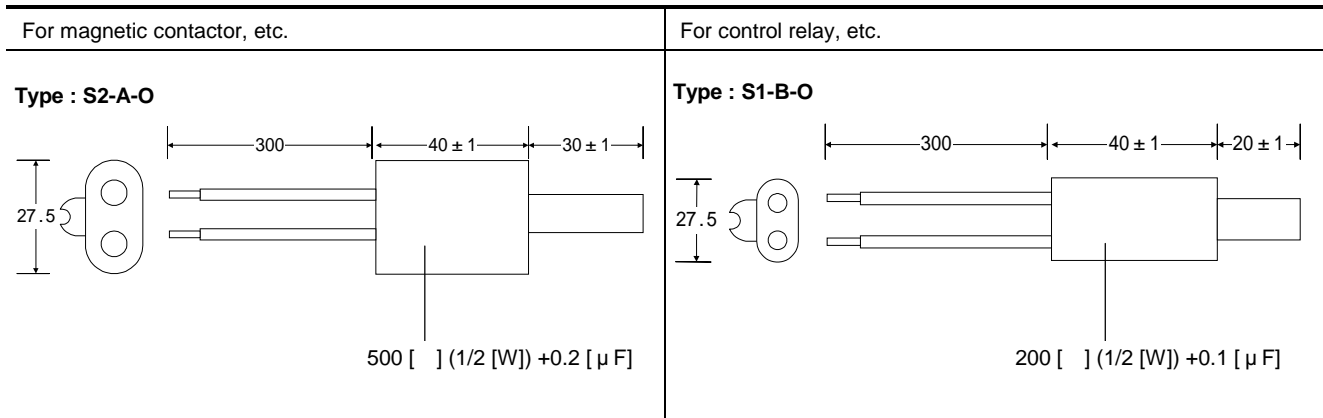

### Protection circuit, example

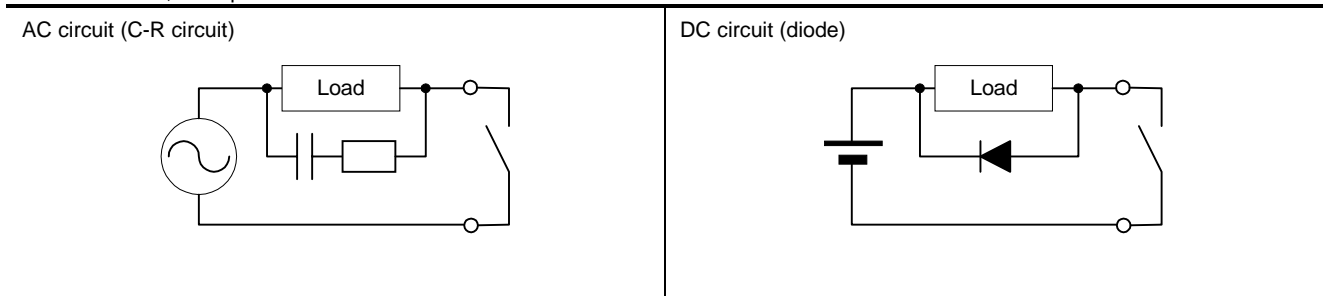

### 11.4 Power filter

Power filter is installed to prevent the PWM circuit in amplifier from exerting influence over the power supply side.

In the amplifier, the PWM circuit performs high frequency switching. This causes power line noise, radiation noise from the amplifier and noise from the motor power cable, and these noises may have an adverse influence over external equipment. To prevent such an influence, the following methods are available. See figure below.

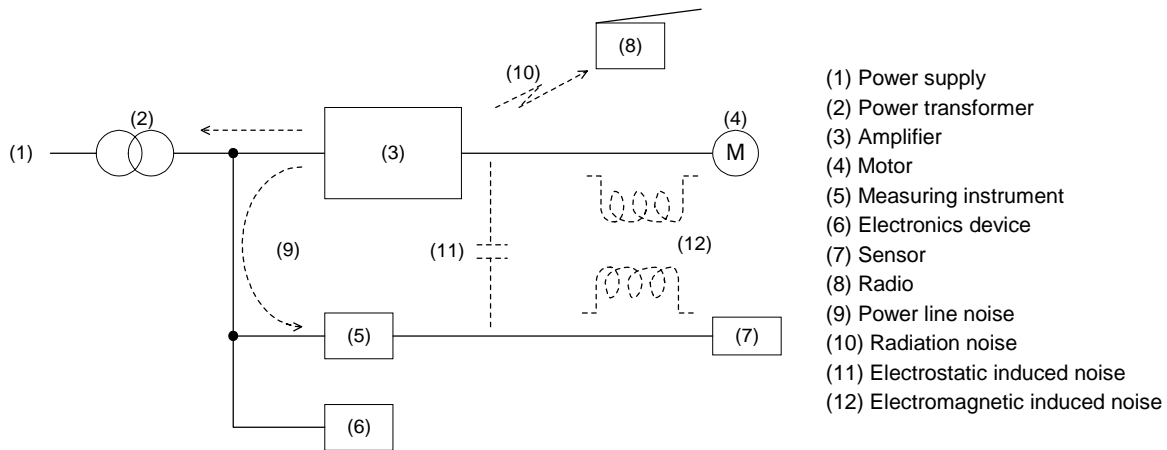

- (a) Installation of amplifier in a grounded steel container. Avoid close installation with personal computer and measuring instrument.
- (b) Installation of power filter at primary side of amplifier to prevent PWM from exerting influence over power source.
- (c) Install the cable from each amplifier to motor in a grounded metal conduit.
- (d) Minimize the distance of ground connection by using a larger size copper bar. Ground connection should be wired to each equipment separately. See figure below.

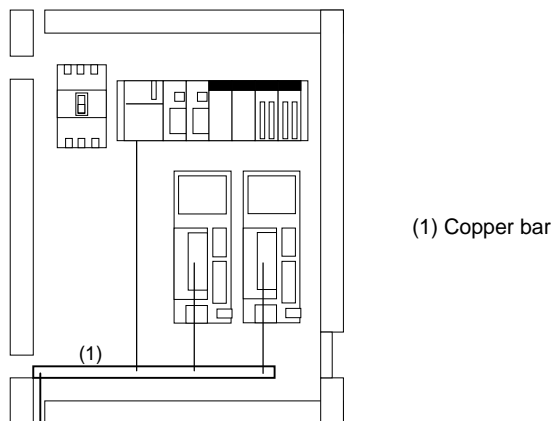

- (e) Avoid mutual connection of the following cables.
  - (i) Ground : Power system and frame (enclosure)
  - (ii) + 24 [V] DC for control input/output and 0 [V] of power supply
  - (iii) 0 [V] power supply : Speed command and encoder
- (f) Avoid binding together the 200 [V] power supply and amplifier output cable, + 24/+ 15 [V] DC control signal cable and encoder cable or laying them in parallel.
- (g) Separate 200 [V] power source with that of 100 [V]-system device by use of an insulating transformer : Fuji "TRAFY", etc. .

Input voltage class	[V]	100		200				
Amplifier output	[kW]	0.05, 0.1	0.2	0.03 to 0.2	0.4	0.75 to 2	3	4, 5
Amplifier type	RYS S3-	6		300 to 201	401	751 to 202	302	402, 502
Power filter type	FHF-TA/	5/250	10/250	5/250	10/250	20/250	30/250	50/250

## 11.5 AC reactor (reactor for impedance matching)

### (1) AC reactor application

Provide and connect an AC reactor in any of the following cases.

(a) Power supply capacity is large

When the power supply capacity exceeds 500 [kVA] (\*), the input current of the amplifier becomes large at the time of power on, and there is a possibility where the rectifying diodes of the amplifier are damaged.

Note : (\*) Cable length of 20 [m] with specified cable diameter size.

(b) Power supply voltage is unbalanced

Connect an AC reactor if the power supply voltage unbalance rate is 3% or higher.

$$\text{Unbalance rate of power supply voltage [\%]} = \frac{\text{Max. voltage [V]} - \text{Min. voltage [V]}}{\text{3-phase average voltage [V]}} \times 100$$

(c) Suppression of higher harmonics

Higher harmonics current is generated because an amplifier is of capacitor input type.

AC reactor suppresses voltage distortion in the power supply system.

### (2) Connection

Connect an AC reactor to the primary (power supply) side of the amplifier.

Input voltage class		[V]	100	200								
Amplifier output		[kW]	0.05 to 0.2	0.03 to 0.2	0.4	0.75	1, 1.5	2	3	4	5	
Amplifier type		RYS S3-	6									
			500 to 201	300 to 201	401	751	102, 152	202	302	402	502	
AC reactor		type	ACR2-	0.4A	0.4A	0.75A	1.5A	2.2A	3.7A	5.5A	7.5A	11A
		reactance	[mH]	2.92	1.57	0.939	0.679	0.406	0.279	0.207	0.145	

## 11.6 External braking resistor : External dimension : See 11.8 (3)

A braking resistor is provided (built-in) with the amplifier for 0.2 [kW] over.

However, if load variation is wide, elevation (hoisting) load, or higher frequent operation, the following external braking resistor should be installed. In such a case, built-in resistor should be disconnected.

### (1) Data of external braking resistor

Input voltage class		[V]	100		200						
Amplifier output		[kW]	0.05, 0.1	0.2	0.03 to 0.2	0.4	0.75	1, 1.5	2, 3	4, 5	
Amplifier type		RYS S3-	6								
			500, 101	201	300 to 201	401	751	102, 152	202, 302	402, 502	
Resistor		type	WSR-401				WSR-751	WSR-152	DB11-2	DB22-2	
		(**) [W]	17				25	75	115		
Resistance		[ ]	68				15		10	5.8	
Built-in resistor		(**) [W]	Not applicable	12	Not applicable	12		20	30	60	
		[ ]	applicable	68	applicable	68	33	18	9	5.5	

Note : (\*\*) Cont. : Continuous operation duty at 25 , allowable

### (2) Data of NTC thermistor embedded in the external braking resistor

Resistor type	Open circuited the thermistor at the following temperature [ ]	Withstand AC voltage tested for one minute [kV]	Contact capacity
WSR- 401	135 ± 5	1.5	30 [V] DC, 0.1 [A]
751		2.5	
152	150 ± 10		120 [V] AC/30 [V] DC, 0.1 [A]
DB 11-2			
22-2			

### (3) External braking resistor connection

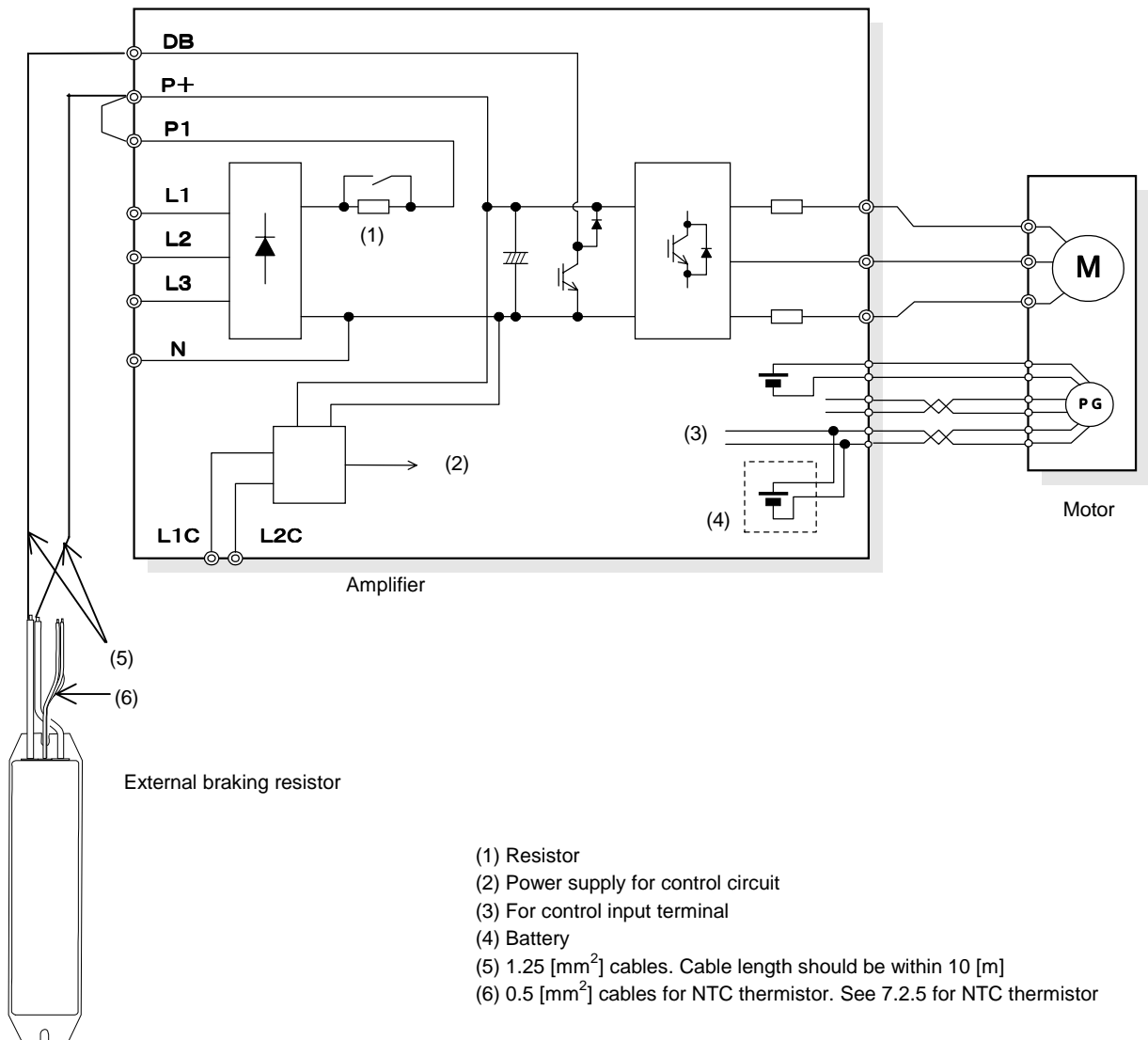

## 11.7 DC reactor

### (1) DC reactor application

Provide and connect an DC reactor in any of the following cases.

(a) Power supply capacity is large

When the power supply capacity exceeds 500 [kVA] (\*), the input current of the amplifier becomes large at the time of power on, and there is a possibility where the rectifying diodes of the amplifier are damaged.

Note : (\*) Cable length of 20 [m] with specified cable diameter size.

(b) Power supply voltage is unbalanced

Connect an DC reactor if the power supply voltage unbalance rate is 3% or higher.

$$\text{Unbalance rate of power supply voltage [\%]} = \frac{\text{Max. voltage [V]} - \text{Min. voltage [V]}}{3\text{-phase average voltage [V]}} \times 100$$

(c) Suppression of higher harmonics

Higher harmonics current is generated in the amplifier.

DC reactor suppresses voltage distortion in the power supply system.

### (2) Connection

Connect an DC reactor to the primary (power supply) side of the amplifier.

Input voltage class	[V]	100			200									
Amplifier output	[kW]	0.05	0.1	0.2	0.03 to 0.1	0.2	0.4	0.75	1, 1.5	2	3	4	5	
Amplifier type	RYS S3-	6												
		500	101	201	300 to 101	201	401	751	102, 152	202	302	402	502	
DC reactor type	DCR2-	0.2	0.4	0.75	0.2	0.4	0.75	1.5	2.2	3.7	5.5	7.5	11	
Inductance	[mH]	20	12	7	20	12	7	4	3	1.7	1.2	0.8	0.6	

### 11.8 Optional cables, connector kits, battery and external braking resistors

#### (1) Connecting cables [unit : mm]

(a) Control input/output (expanded I/O of L and R types)

Cable type : WSC-D20P03 (20-pin)

Application : CN3 of RYS S3-LPS, RPS amplifier

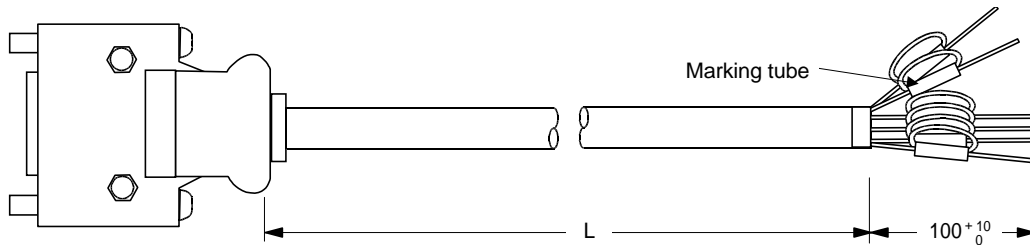

(i) Connector : CN1

Plug	10120-3000V
Shell	10320-52A0-008

(ii) Wire color

Pin No. for CN1	1	2	3	4	5	6	7	8	9	10	11	12	13	14	15	16	17	18	19	20
Marking tube	1	2	3	4	5	6	7	8	9	10	11	12	13	14	15	16	17	18	19	20
Wire color	Orange		Gray		White		Yellow		Pink		Orange		Gray		White		Yellow		Pink	
Marking	Red 1	Black 1	Red 1	Black 1	Red 1	Black 1	Red 1	Black 1	Red 1	Black 1	Red 2	Black 2	Red 2	Black 2	Red 2	Black 2	Red 2	Black 2	Red 2	Black 2

(iii) Cable length (L) and mass

Cable type	L [mm]	Mass [g]
WSC-D20P03	$3000^{+300}_0$	400

(b) Control input/output (SX bus, T-link, RS485)

Cable type : WSC-D26P03 (26-pin)

Application : CN1, other than the RYS S3-VVS, LPS, RPS amplifier

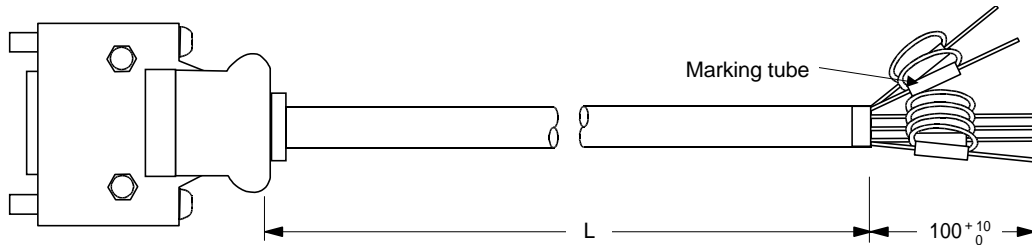

(i) Connector : CN1

Plug	10126-3000V
Shell	10326-52A0-008

(ii) Wire color

Pin No. for CN1	1	2	3	4	5	6	7	8	9	10	11	12	13	14	15	16	17	18	19	20
Marking tube	1	2	3	4	5	6	7	8	9	10	11	12	13	14	15	16	17	18	19	20
Wire color	Orange		Gray		White		Yellow		Pink		Orange		Gray		White		Yellow		Pink	
Marking	Red 1	Black 1	Red 1	Black 1	Red 1	Black 1	Red 1	Black 1	Red 1	Black 1	Red 2	Black 2	Red 2	Black 2	Red 2	Black 2	Red 2	Black 2	Red 2	Black 2

Pin No. for CN1	21	22	23	24	25	26
Marking tube	21	22	23	24	25	26
Wire color	Orange		Gray		White	
Marking	Red 3	Black 3	Red 3	Black 3	Red 3	Black 3

(iii) Cable length (L) and mass

Cable type	L [mm]	Mass [g]
WSC-D26P03	$3000^{+300}_0$	450

(c) Control input/output

Cable type : WSC-D36P03 (36-pin)

Application : CN1 of RYS S3-VVS, LPS, RPS amplifier

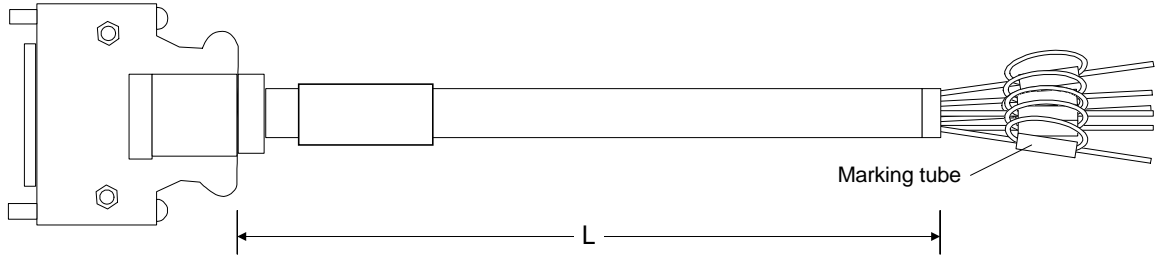

(i) Connector : CN1

Plug	10136-3000V
Shell	10336-52A0-008

(ii) Wire color

Pin No. for CN1	1	2	3	4	5	6	7	8	9	10	11	12	13	14	15	16	17	18	19	20
Marking tube	1	2	3	4	5	6	7	8	9	10	11	12	13	14	15	16	17	18	19	20
Wire color	Orange		Gray		White		Yellow		Pink		Orange		Gray		White		Yellow		Pink	
Marking	Red 1	Black 1	Red 1	Black 1	Red 1	Black 1	Red 1	Black 1	Red 1	Black 1	Red 2	Black 2	Red 2	Black 2	Red 2	Black 2	Red 2	Black 2	Red 2	Black 2

Pin No. for CN1	21	22	23	24	25	26	27	28	29	30	31	32	33	34	35	36
Marking tube	21	22	23	24	25	26	27	28	29	30	31	32	33	34	35	36
Wire color	Orange		Gray		White		Yellow		Pink		Orange		Gray		White	
Marking	Red 3	Black 3	Red 3	Black 3	Red 3	Black 3	Red 3	Black 3	Red 3	Black 3	Red 4	Black 4	Red 4	Black 4	Red 4	Black 4

(iii) Cable length (L) and mass

Cable type	L [mm]	Mass [g]
WSC-D36P03	3000 <sup>+300</sup> <sub>0</sub>	550

(d) Encoder cable

Cable type : WSC-P06P05, P06P10 and P6P20

Application : 0.75 [kW] and below

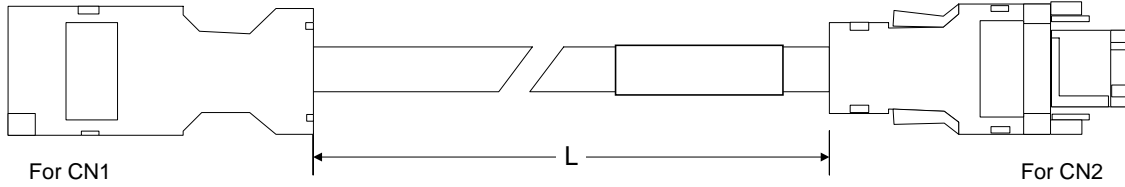

(i) Connector

1) CN1

Housing		53988 - 0611
Socket	shell cover	58300 - 0600
	mold cover	53989 - 0605
		53990 - 0605
Cable clamp		53303 - 0000
Clamp screw		59832 - 0009

2) CN2 (5 or 10 [m] cable length)

Housing		51145 - 0601
Terminal		50639 - 8091
Plug shell	cover	58098 - 0600
	body	58099 - 0600
Cable clamp		54017 - 0615
Clamp screw		54018 - 0605

3) CN2 (20 [m] cable length)

Plug	housing	54180 - 0611
	shell cover	58299 - 0600
	shell body	58300 - 0600
	mold cover	54181 - 0615
54182 - 0605		
Cable clamp		58303 - 0000
Clamp screw		59832 - 0009

(ii) Wire color

Pin No. for	CN1	1	2	3	4	5	6
	CN2	1	2	3	4	5	6
Wire color		Red	Black	Orange	Orange / White	Sky blue	Sky blue / White
	or	White	Black	Yellow	Brown	Red	Blue

(iii) Cable length (L) and mass

Cable type		L [mm]	Mass [g]
WSC-P06	P05	$5000^{+500}_0$	300
	P10	$10000^{+1000}_0$	500
	P20	$20000^{+2000}_0$	1200



**CAUTION**

**Do not extend the wiring distance by connecting two or more encoder wiring cables.  
A voltage drop by contact resistance of connector may stop the operation abruptly.**

(e) Encoder cable

Cable type : WSC-P06P05-C, P06P10-C and P06P20-C

Application : 1 [kW] and above

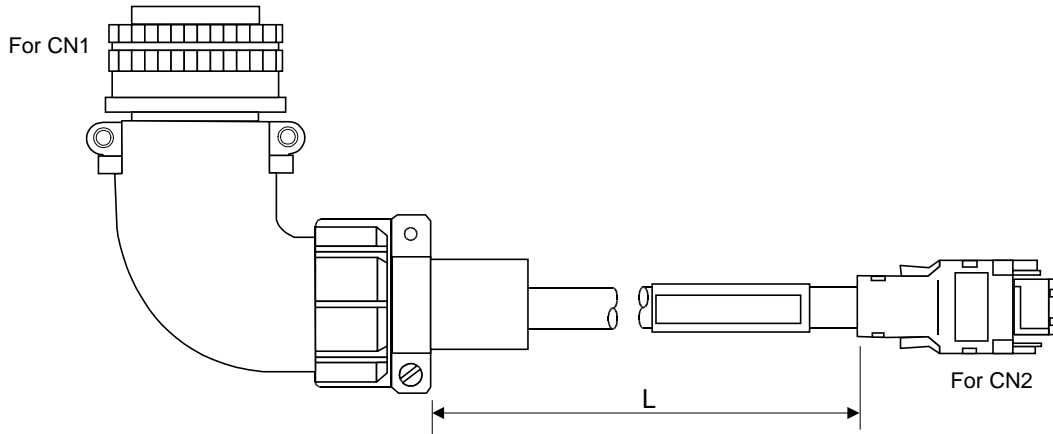

(i) Connector

1) CN1

Connector	MS3108B20 - 29S
Cable clamp	MS3057 - 12A

2) CN2

Plug	housing	54180 - 0611
	shell cover	58299 - 0600
	shell body	58300 - 0600
	mold cover	54181 - 0615
54182 - 0605		
Cable clamp		58303 - 0000
Clamp screw		59832 - 0009

(ii) Wire color

Pin No. for	CN1	H	G	T	S	C	D
	CN2	1	2	3	4	5	6
Wire color	Red	Black	Orange	Orange / White	Sky blue	Sky blue / White	
or	White	Black	Yellow	Brown	Red	Blue	

(iii) Cable length (L) and mass

Cable type		L [mm]	Mass [g]
WSC-P06	P05-C	5000 <sup>+500</sup> <sub>0</sub>	450
	P10-C	10000 <sup>+1000</sup> <sub>0</sub>	650
	P20-C	20000 <sup>+2000</sup> <sub>0</sub>	1400

(f) Encoder cable

Cable type : WSC-P06P05-W, P06P10-W and P06P20-W

Application : 1.5 [kW] and above

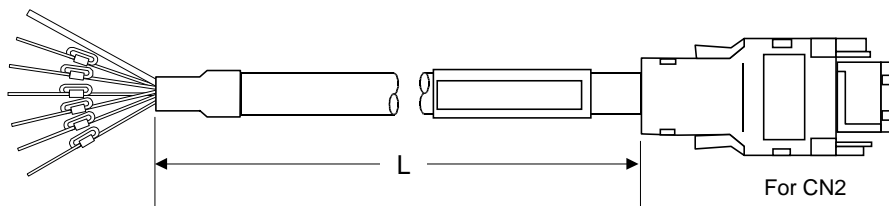

(i) Connector

Housing	54180 - 0611	
Plug shell	cover	58299 - 0600
	body	58300 - 0600
Cable clamp	54181 - 0615	
Clamp screw	54182 - 0605	

(ii) Wire color

Marking tube	P5	M5	BAT+	BAT -	SIG+	SIG -
Pin No. for CN2	1	2	3	4	5	6
Wire color	Red	Black	Orange	Orange / White	Sky blue	Sky blue / White
	or White	Black	Yellow	Brown	Red	Blue

(iii) Cable length (L)

Cable type	L [mm]	Mass [g]	
WSC-P06	P05-W	$5000^{+500}_0$	300
	P10-W	$10000^{+1000}_0$	500
	P20-W	$20000^{+2000}_0$	1200

(g) Motor power cable for motor without providing brake

Cable type : WSC-M04P05, M04P10 and M04P20

Application : 0.75 [kW] and below

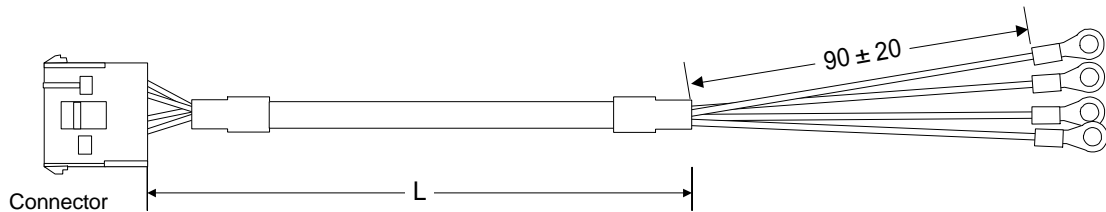

(i) Connector

Cap housing	350780 - 1
Socket	350570 - 1

(ii) Wire color

Pin No. for CN1	1	2	3	4
Marking	U	V	W	E
Cable color	Red	White	Black	Green / Yellow

(iii) Cable length (L) and mass

Cable type	L [mm]	Mass [g]	
WSC-M04	P05	$5000^{+500}_0$	700
	P10	$10000^{+1000}_0$	1400
	P20	$20000^{+2000}_0$	2700

(h) Motor power cable for motor with providing brake  
 Cable type : WSC-M06P05, M06P10 and M06P20  
 Application : 0.75 [kW] and below

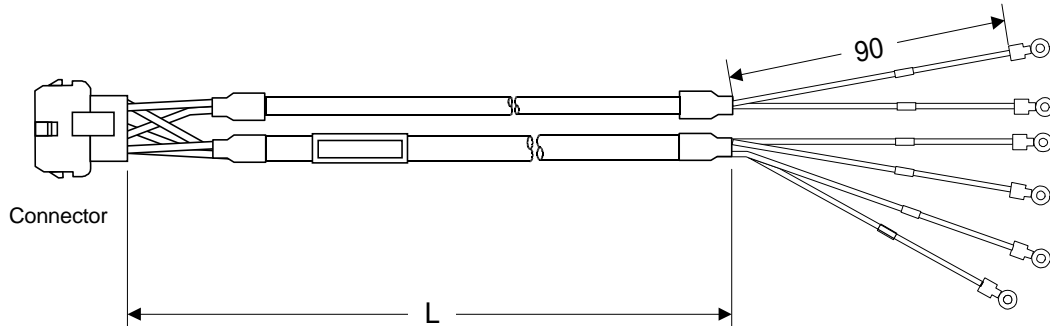

(i) Connector

Cap housing	350781 - 1
Socket	350570 - 1

(ii) Wire color

Pin No. for CN1	1	2	3	4	5	6
Marking	U	V	W	E		
Wire color	Red	White	Black	Green / Yellow	Red	Black

(iii) Cable length (L) and mass

Cable type	L [mm]	Mass [g]
WSC-M06 P05	5000 <sup>+500</sup> <sub>0</sub>	900
	10000 <sup>+1000</sup> <sub>0</sub>	1750
	20000 <sup>+2000</sup> <sub>0</sub>	3400

**(2) Connector kits [unit : mm]**

(a) Control input/output (expanded I/O for L, R types)

Connector kit type : WSK-D20P (20-pin)

Application : CN3 of RYS S3-LPS, RPS amplifier

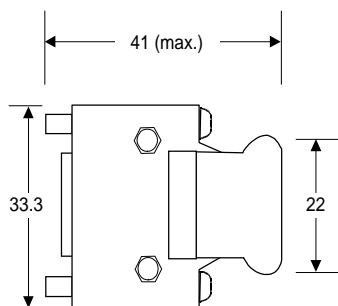

Plug	10120 - 3000VE
Shell kit	10320 - 52A0 - 008

Mass : 20 [g]

(b) Control input/output (SX bus, T-link, RS485)

Connector kit type : WSK-D26P (26-pin)

Application : CN1 of other than the RYS

S3-VVS, LPS, RPS amplifier

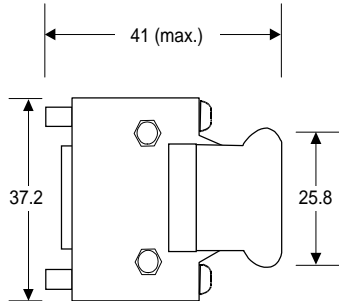

Plug	10126 - 3000VE
Shell kit	10326 - 52A0 - 008

Mass : 20 [g]

(c) Control input/output

Connector kit type : WSK-D36P (36-pin)

Application : CN1 of RYS

S3-VVS, LPS, RPS amplifier

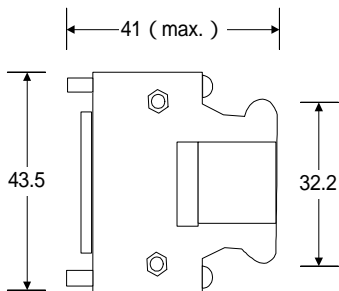

Plug	10136 - 3000V
Shell kit	10336 - 52A0 - 008

Mass : 20 [g]

(d) Encoder

Connector kit type for amplifier side (CN2) : WSK-P06-M

Application : 0.75 [kW] and below

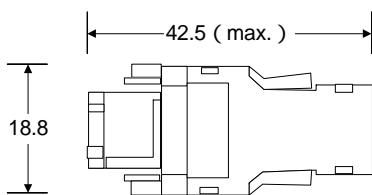

Housing	54180 - 0611
Shell cover	58299 - 0600
	58300 - 0600
Mold cover	54181 - 0615
	54182 - 0605
Cable clamp	58303 - 0000
Clamp screw	59832 - 0009

Mass : 10 [g]

(e) Encoder

Connector kit type for motor side (CN2) : WSK-P06P-F

Application : 0.75 [kW] and below

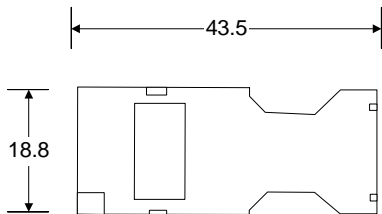

Mass : 10 [g]

Housing	53988 - 0611
Shell baby, clamp side	58302 - 0600
Mold cover, latch side	53989 - 0605
Mold cover	53990 - 0605
Cable clamp	58303 - 0000
Clamp screw	59832 - 0009

(f) Encoder

Connector kit type for motor side (CN2) : WSK-P06P-C

Application : 1 [kW] and above

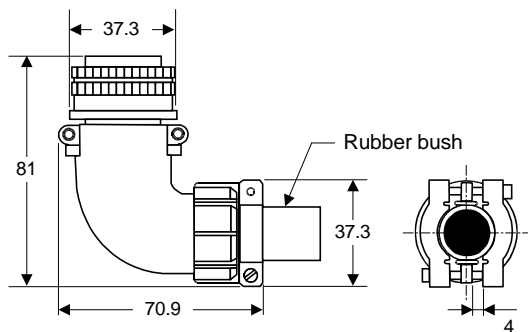
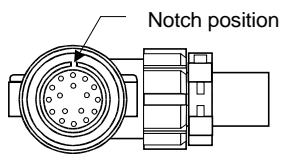

Connector	MS3108B20 - 29S
Cable clamp	MS3057 - 12A

Mass : 150 [g]

(g) Motor power for motor without providing brake

Connector kit type : WSK-M04P (4-pin)

Application : 0.75 [kW] and below

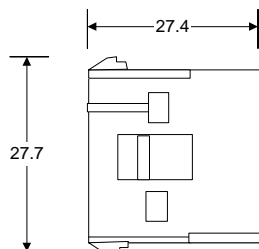

Cap	350780 - 1
Shell body, clamp side	350570 - 1 or 350689 - 3

Mass : 10 [g]

(h) Motor power for motor without providing brake  
 Connector kit type : WSK-M04P-CA (4-pin)  
 Application : GYS type motor 1 to 2 [kW]

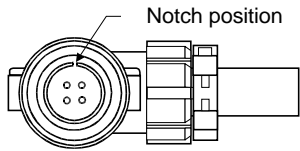

Connector	MS3108B18 - 10S
Cable clamp	MS3057 - 10A

Mass : 100 [g]

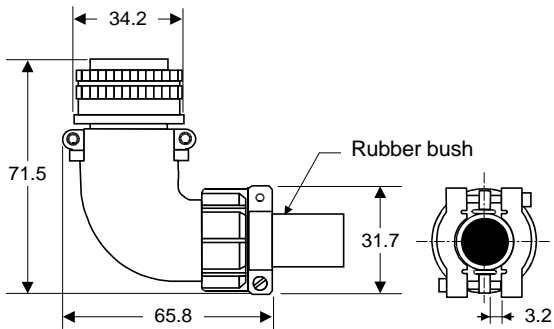

(i) Motor power for motor without providing brake  
 Connector kit type : WSK-M04P-CB (4-pin)  
 Application : GYC type motor 1 [kW] and above, GYS type motor 3 [kW] and above

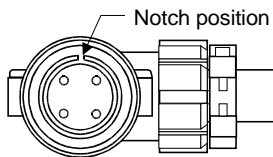

Connector	MS3108B22 - 22S
Cable clamp	MS3057 - 12A

Mass : 150 [g]

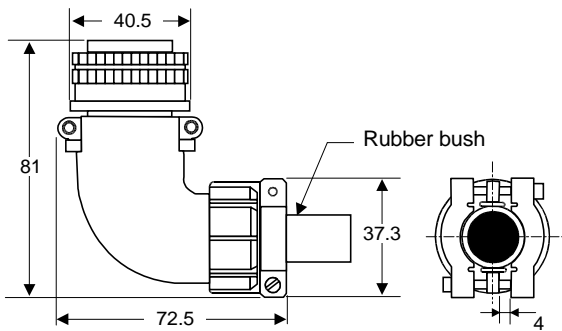

(j) Motor power for motor with providing brake  
 Connector kit type : WSK-M06P (6-pin)  
 Application : 0.75 [kW] and below

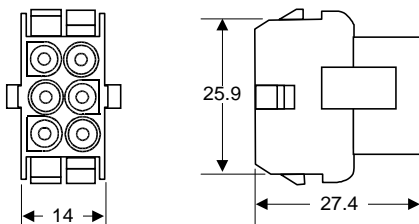

Cap housing	350781 - 1
Socket	350570 - 1

Mass : 10 [g]

(k) Motor power for motor with providing brake  
 Connector kit type : WSK-M06P-CA (6-pin)  
 Application : GYS type motor 1 to 2 [kW]

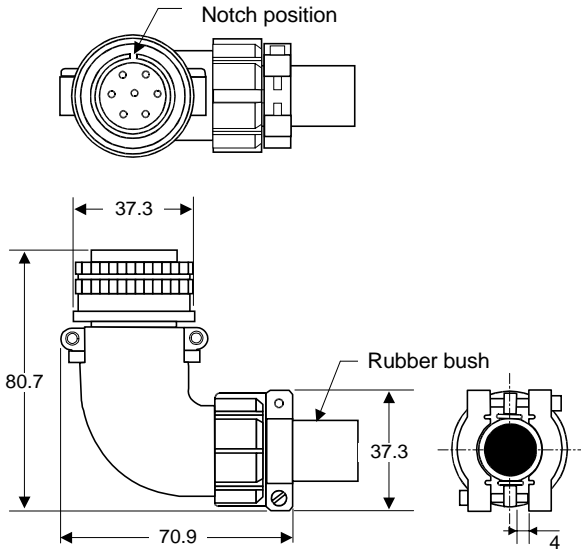

Connector	MS3108B20 - 15S
Cable clamp	MS3057 - 12A

Mass : 150 [g]

(l) Motor power for motor with providing brake  
 Connector kit type : WSK-M06P-CB (6-pin)  
 Application : GYC type motor 1 [kW] and above, GYS type motor 3 [kW] and above

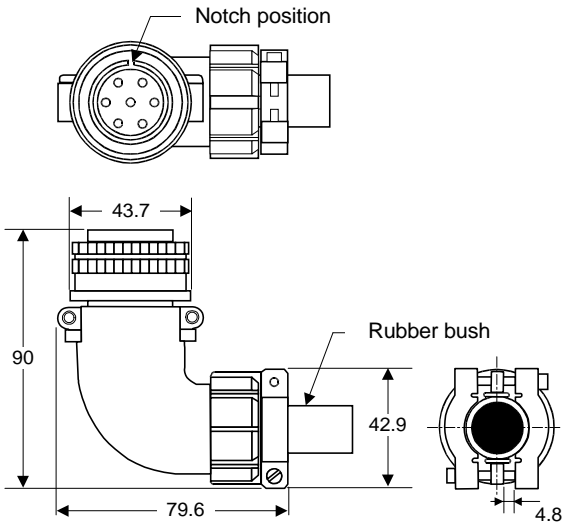

Connector	MS3108B24 - 10S
Cable clamp	MS3057 - 16A

Mass : 200 [g]

(m) Control power input  
 Connector kit type : WSK-L02P  
 Application : 1.5 [kW] and below

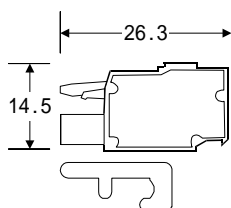

Connector	231702/026 - 000
Manual lever	231 - 131

Mass : 5 [g]

(n) Battery

Connector kit type : WSB - S

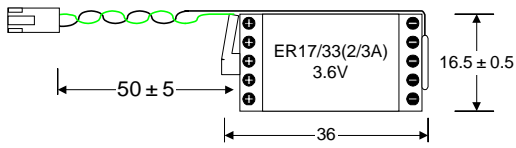

Battery	ER1733WK41 1PP
• Nominal voltage : 3.6 [V]	
• Capacity : 1500 [mAh]	
• Mass : 15 [g]	

Storage of battery

If a battery has been out of service for long-term, the following procedures should be followed.

Battery should be stored in the storeroom. The storeroom should be well ventilated, and selected for possible protection against temperature and moisture.

Surrounding condition should be kept within - 10 to + 75 temperature and 10 to 90% RH humidity.

Storage term should be within two years.

(3) External braking resistor [unit : mm]

(a) Resistor type : WSR-401

Application : RYS type amplifier 0.4 [kW] and below

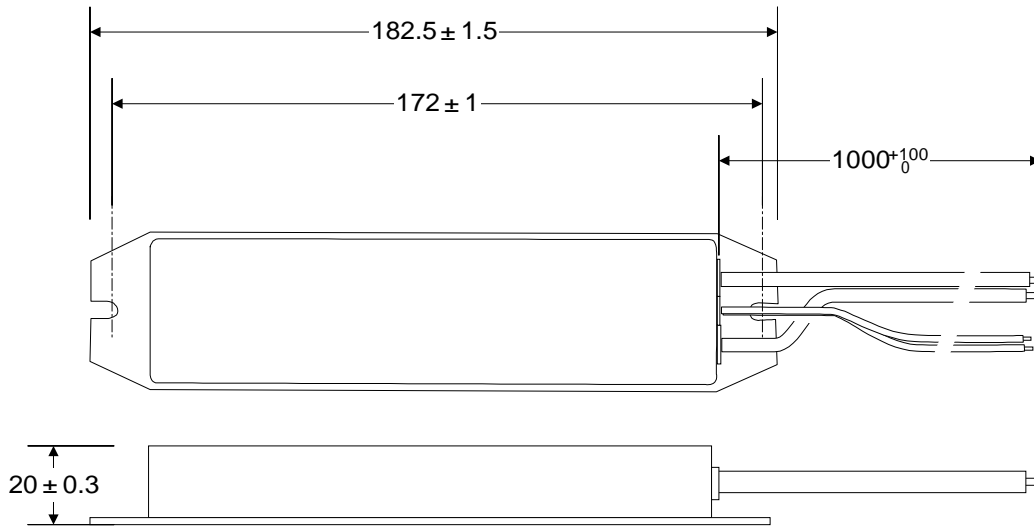

Thickness of mounting plate is 1.2 [mm], mass : 235 [g]

(b) Resistor type : WSR-751

Application : RYS type amplifier 0.75 [kW]

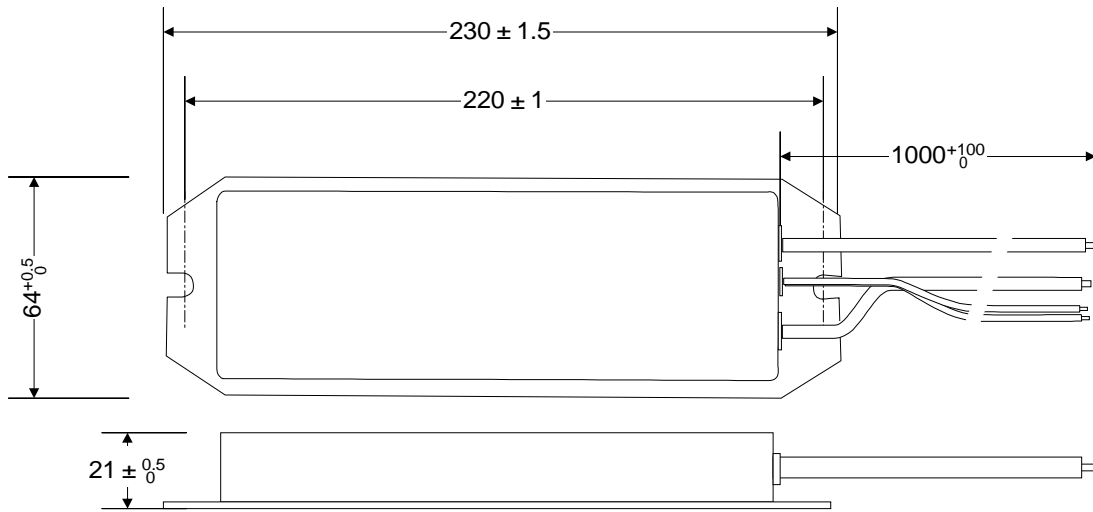

Thickness of mounting plate is 1.5 [mm], mass : 520 [g]

(c) Resistor type : WSR-152

Application : RYS type amplifier 1 and 1.5 [kW]

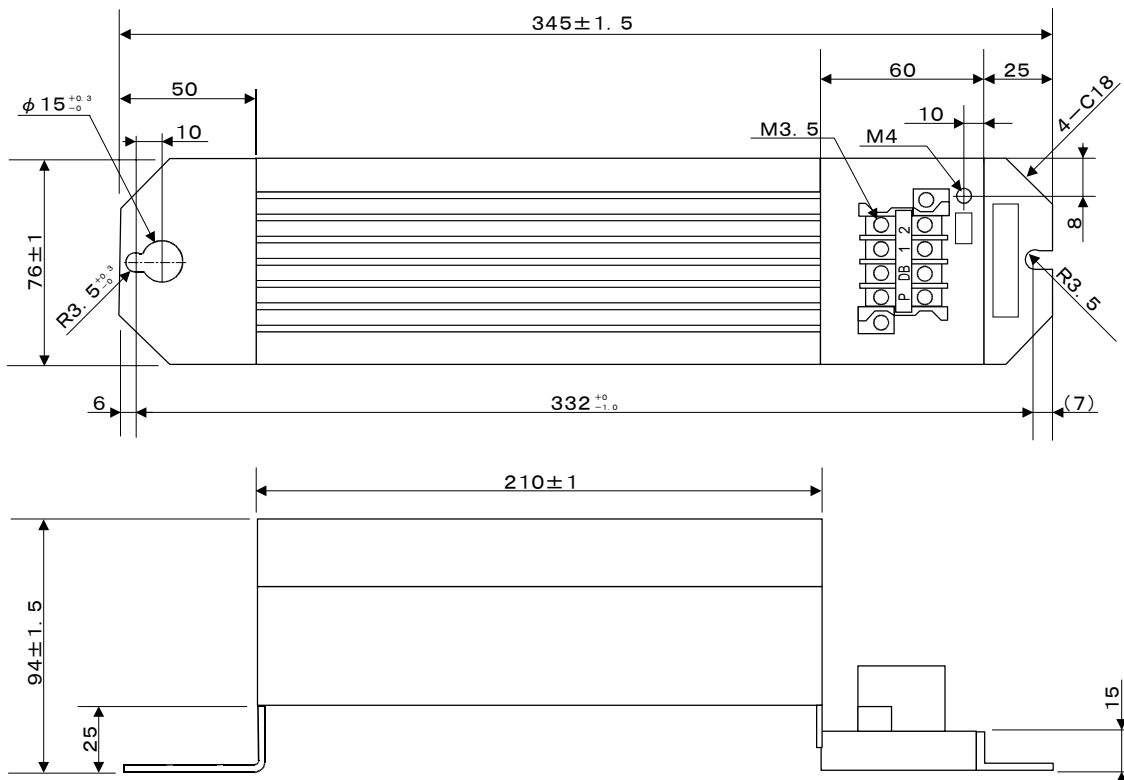

Thickness of mounting plate is 2 [mm], mass : 2000 [g]

(d) Resistor type : DB11-2  
 Application : RYS type amplifier 2 and 3 [kW]

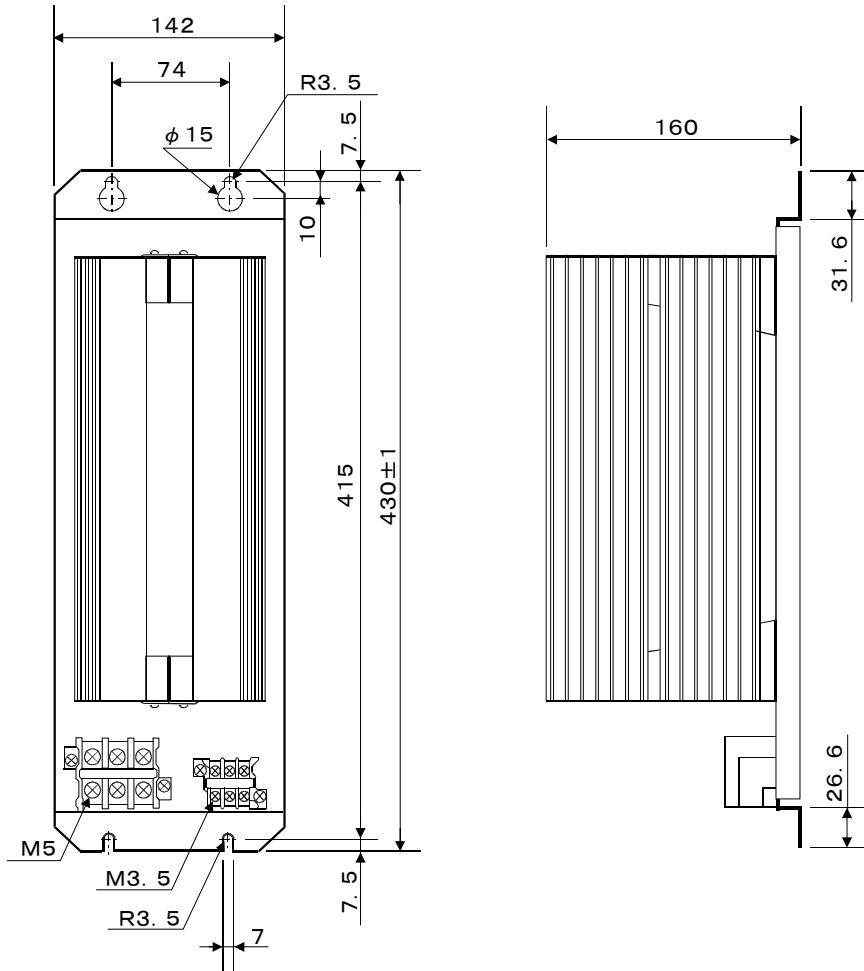

Thickness of mounting plate is 1.6 [mm], mass : 6900 [g]

(e) Resistor type : DB22-2  
 Application : RYS type amplifier 4 and 5 [kW]

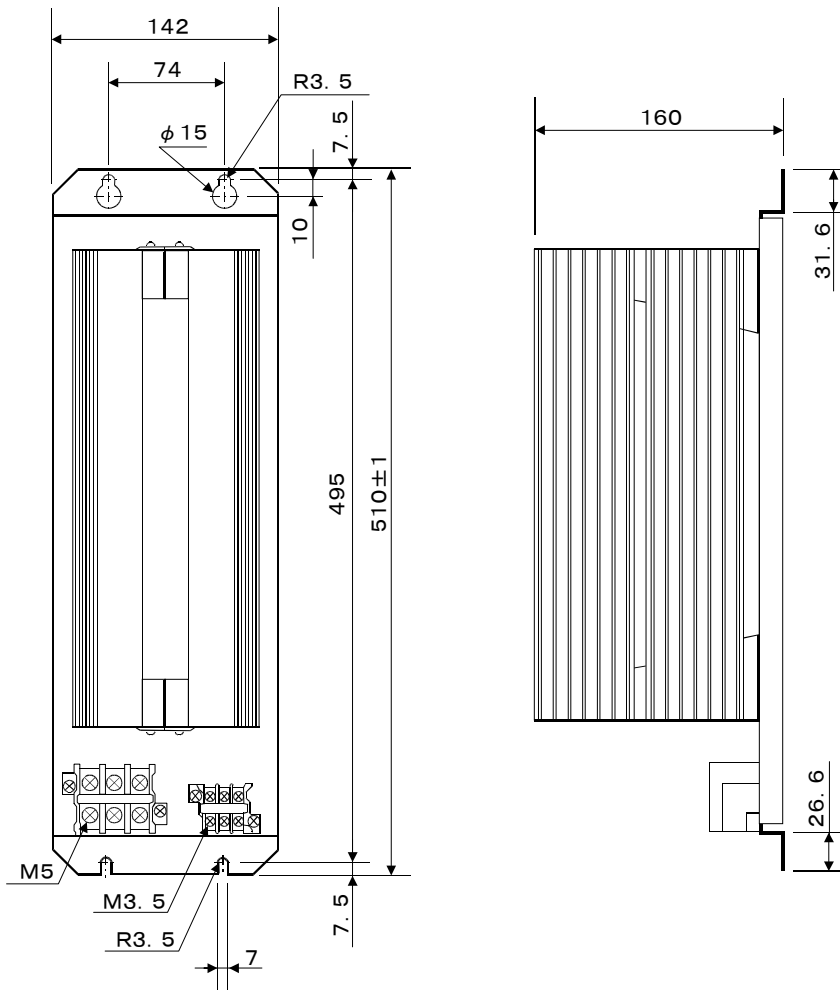

Thickness of mounting plate is 1.6 [mm], mass : 8700 [g]

## 12. APPENDIXES

### 12.1 Model type selection

#### (1) Load machine system

Load machine systems driven by adjustable (variable) speed motor are generally as follows.

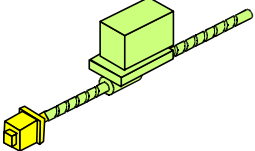
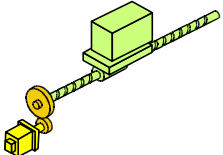
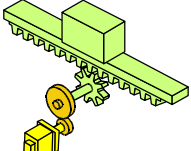
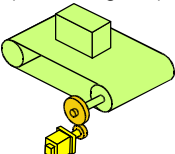
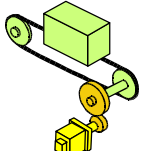
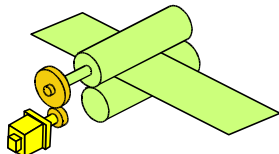
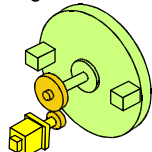
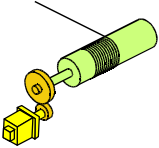
Mechanical system	Description
Ball-screw (with direct coupling) 	Used for high-accuracy positioning in a short distance.
Ball-screw (with reduction gear) 	Load torque is increased through deceleration. Compensation is required for gear backlash.
Rack and pinion 	Used for positioning in a long distance. Movement per revolution of pinion involves a value. compensation is required.
Conveyor (with timing belt) 	Used for light loads. compensation is required.
Chain drive 	Mostly used for transfer line, etc. For positioning, countermeasures for chain elongation is needed. Reduction ratio is large. Moving speed of load machine system is low.
Feed roll drive 	A material having a plate shape is emitted and sandwiched between rolls. An error appears over a large length due to a difference in roll diameter. compensation is required. Feed amount becomes inadequate due to slip at rapid accel./decel..
Table indexing 	A large reduction speed ratio is required for a large inertia moment of the machine table. Rotational speed of the table is low and a worm-gear is often used.
Spindle drive 	In winding of wire material, etc., inertia moment becomes larger. Larger reduction speed is necessary. For constant peripheral velocity control, a control system should be checked.

In designing the mechanical equipment system, the following should be examined as required.

(a) Reduction gear ratio

Use near the rated speed of motor is recommended where possible.

(b) Pre-load torque

When applying a pre-load to screw, load torque increases.

(c) Holding torque at vertical drive.

At stop of a vertical-feed load machine, energized-motor has a holding torque unless an external-braking device is used.

(d) Mechanical efficiency

(e) Rough estimated mechanical-coefficients

(i) Friction coefficient  $\mu$

Application	$\mu$
Rail and iron wheel (crane traveling, traverse motion, traveling carriage)	0.05
Linear way	0.05 to 0.2
Linear pole slide unit	
Roller system	

(ii) Mechanical efficiency

Application		
Screw		0.5 to 0.8
Ball-screw		0.9
Rack and pinion		0.8
Spur gear reduction		0.8 to 0.95
Worm reduction gear	At start	0.5 to 0.7
	During operation	0.6 to 0.8
Belt drive		0.95
Chain drive		0.9

(iii) Densities of major materials [kg/m<sup>3</sup>]

Steel	7850
Stainless steel	7910
Copper	8960
Aluminum	2700
Brass	8540
Poly-acetal	1430

## (2) Model type selection determination

(a) Flow chart for selecting a model type

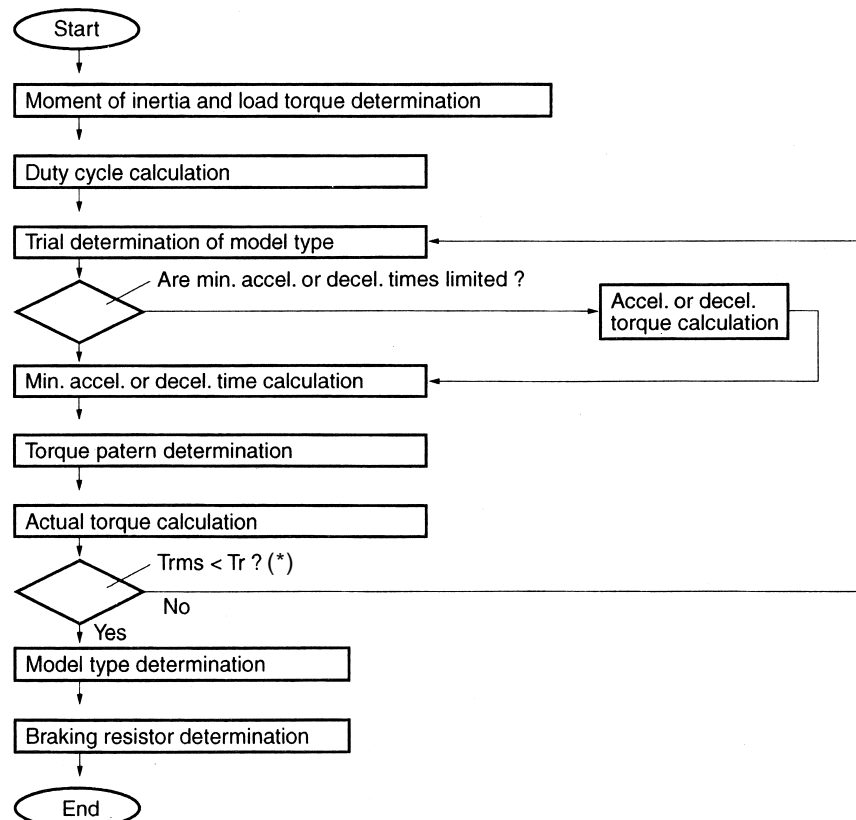

(\*) : Trms : Actual torque  
Tr : Rated torque

(b) Moment of inertia, basic form

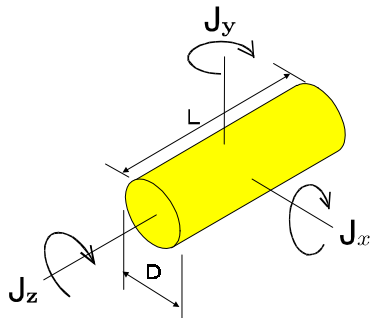

$$J_z = \frac{W}{8} \left( \frac{D}{10^3} \right)^2$$

$$= \frac{1}{32} \left( \frac{L}{10^3} \right) \left( \frac{D}{10^3} \right)^4$$

$$J_x = J_y = \frac{W}{16} \left( \frac{D}{10^3} \right)^2 + \frac{W}{12} \left( \frac{L}{10^3} \right)^2$$

$$W = \frac{1}{4} \left( \frac{L}{10^3} \right) \left( \frac{D}{10^3} \right)^2$$

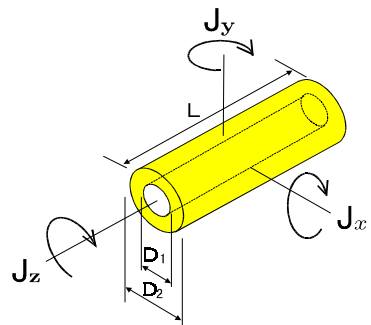

$$J_z = \frac{W}{8} \left( \left( \frac{D_2}{10^3} \right)^2 + \left( \frac{D_1}{10^3} \right)^2 \right)$$

$$= \frac{1}{32} \left( \frac{L}{10^3} \right) \left( \left( \frac{D_2}{10^3} \right)^2 + \left( \frac{D_1}{10^3} \right)^2 \right)$$

$$J_x = J_y = \frac{W}{16} \left( \left( \frac{D_2}{10^3} \right)^2 + \left( \frac{D_1}{10^3} \right)^2 \right) + \frac{W}{12} \left( \frac{L}{10^3} \right)^2$$

$$W = \frac{1}{4} \left( \frac{L}{10^3} \right) \left( \left( \frac{D_2}{10^3} \right)^2 + \left( \frac{D_1}{10^3} \right)^2 \right)$$

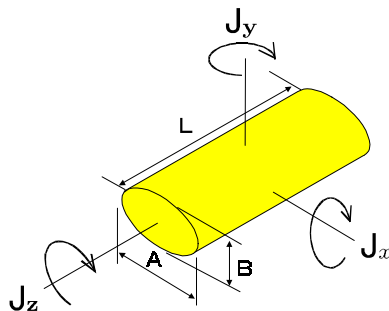

$$J_z = \frac{W}{16} \left( \left( \frac{A}{10^3} \right)^2 + \left( \frac{B}{10^3} \right)^2 \right)$$

$$J_x = \frac{W}{16} \left( \frac{B}{10^3} \right)^2 + \frac{W}{12} \left( \frac{L}{10^3} \right)^2$$

$$J_y = \frac{W}{16} \left( \frac{A}{10^3} \right)^2 + \frac{W}{12} \left( \frac{L}{10^3} \right)^2$$

$$W = \frac{1}{4} \left( \frac{A}{10^3} \right) \left( \frac{B}{10^3} \right) \left( \frac{L}{10^3} \right)$$

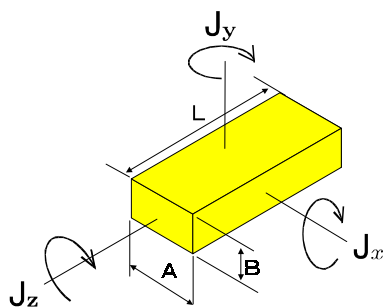

$$J_z = \frac{W}{12} \left( \left( \frac{B}{10^3} \right)^2 + \left( \frac{L}{10^3} \right)^2 \right)$$

$$J_x = \frac{W}{12} \left( \left( \frac{L}{10^3} \right)^2 + \left( \frac{A}{10^3} \right)^2 \right)$$

$$J_y = \frac{W}{12} \left( \left( \frac{A}{10^3} \right)^2 + \left( \frac{B}{10^3} \right)^2 \right)$$

$$W = \left( \frac{A}{10^3} \right) \left( \frac{B}{10^3} \right) \left( \frac{L}{10^3} \right)$$

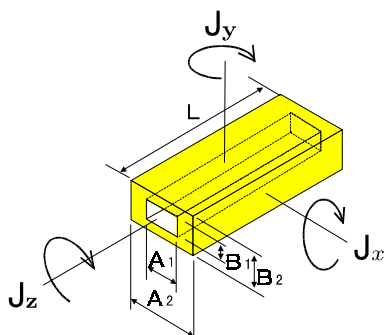

$$J_x = \frac{W_2}{12} \left( \left( \frac{B_2}{10^3} \right)^2 + \left( \frac{L}{10^3} \right)^2 \right) - \frac{W_1}{12} \left( \left( \frac{B_1}{10^3} \right)^2 + \left( \frac{L}{10^3} \right)^2 \right)$$

$$J_y = \frac{W_2}{12} \left( \left( \frac{A_2}{10^3} \right)^2 + \left( \frac{L}{10^3} \right)^2 \right) - \frac{W_1}{12} \left( \left( \frac{A_1}{10^3} \right)^2 + \left( \frac{L}{10^3} \right)^2 \right)$$

$$J_z = \frac{W_2}{12} \left( \left( \frac{A_2}{10^3} \right)^2 + \left( \frac{B_2}{10^3} \right)^2 \right) - \frac{W_1}{12} \left( \left( \frac{A_1}{10^3} \right)^2 + \left( \frac{B_1}{10^3} \right)^2 \right)$$

$$W = \left( \left( \frac{A_2}{10^3} \right) \left( \frac{B_2}{10^3} \right) - \left( \frac{A_1}{10^3} \right) \left( \frac{B_1}{10^3} \right) \right) \left( \frac{L}{10^3} \right)$$

$$W_2 = \left( \frac{A_2}{10^3} \right) \left( \frac{B_2}{10^3} \right) \left( \frac{L}{10^3} \right) \quad W_1 = \left( \frac{A_1}{10^3} \right) \left( \frac{B_1}{10^3} \right) \left( \frac{L}{10^3} \right)$$

(c) Moment of inertia, typical application

Ball-screw

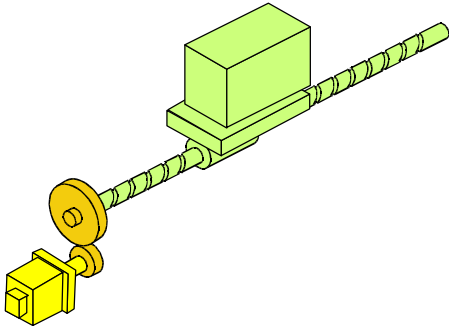

$$J_1 = W \left( \frac{1}{2} \times \frac{BP}{10^3} \right)^2 \times GL^2$$

Rack and pinion, conveyor or chain drive

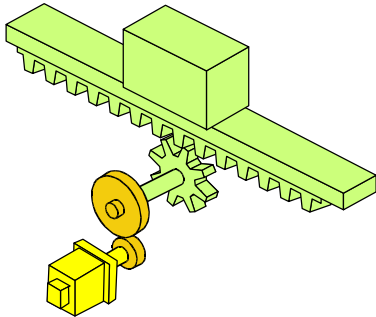

$$J_2 = \frac{W}{4} \left( \frac{D}{10^3} \right)^2 \times GL^2$$

Feed roll drive

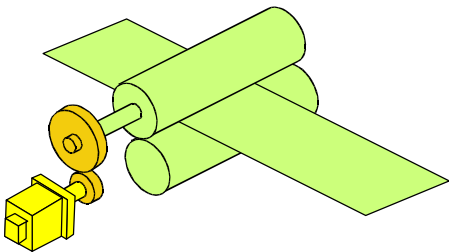

$$J_3 = \frac{W}{4} \left( \frac{D}{10^3} \right)^2 \times GL^2$$

Table indexing

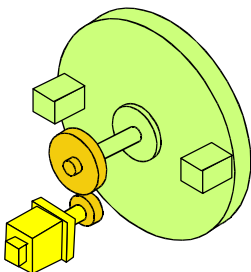

$$J_4 = \left( J + W \left( \frac{L}{10^3} \right)^2 \right) \times GL^2$$

(d) Torque determination

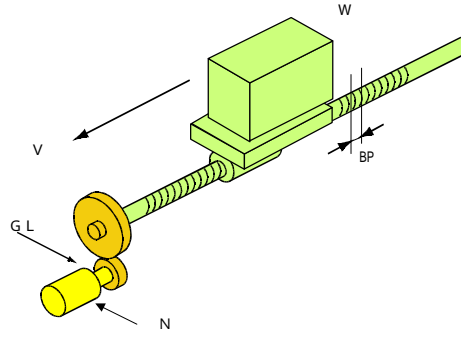
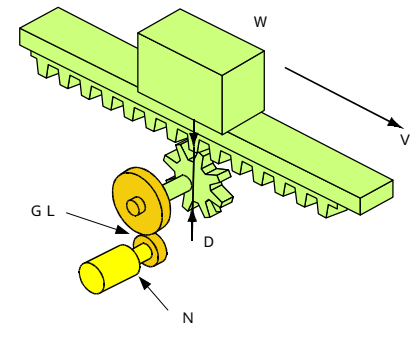
<p>Ball-screw</p> 	$T_L = \frac{(\mu W + F) \times 9.81 \left( \frac{BP}{10^3} \right) \times GL}{2\pi\eta}$ <ul style="list-style-type: none"> <li>• <math>T_L</math> at load lifting :</li> <li>• <math>T_L</math> at lowering :</li> <li>• <math>T_L</math> at stop (servo lock) :</li> </ul>
$T_L = \frac{((\mu + 1)W_1 - W_2) \times 9.81 \left( \frac{BP}{10^3} \right) \times GL}{2\pi\eta}$ $T_L = \frac{((\mu - 1)W_1 - W_2) \times 9.81 \left( \frac{BP}{10^3} \right) \times GL}{2\pi\eta}$ $T_L = \frac{(W_1 - W_2) \times 9.81 \left( \frac{BP}{10^3} \right) \times GL}{2\pi\eta}$	$T_L = \frac{(\mu W + F) \times 9.81 \left( \frac{D}{2} \times \frac{1}{10^3} \right) \times GL}{\eta}$ <ul style="list-style-type: none"> <li>• <math>T_L</math> at load lifting :</li> <li>• <math>T_L</math> at lowering :</li> <li>• <math>T_L</math> at stop (servo lock) :</li> </ul>
<p>Rack and pinion, conveyor</p> 	$T_L = \frac{((\mu + 1)W_1 - W_2) \times 9.81 \left( \frac{D}{2} \times \frac{1}{10^3} \right) \times GL}{\eta}$ $T_L = \frac{((\mu - 1)W_1 - W_2) \times 9.81 \left( \frac{D}{2} \times \frac{1}{10^3} \right) \times GL}{\eta}$ $T_L = \frac{(W_1 - W_2) \times 9.81 \left( \frac{D}{2} \times \frac{1}{10^3} \right) \times GL}{\eta}$

Where

- BP : Screw-pitch
- D : Pulley, pinion or roll diameter
- F : Thrust (axial) force (opposes feed on is + direction)
- GL : Reduction speed ratio
- J : Moment of inertia, total
- $J_L$  : Ditto, load parts
- $J_M$  : Ditto, motor rotor
- where,
- $J_L = J_M \times 100$  : Load of low moving velocity
- $J_L = J_M \times 50$  : Load of positioning
- $J_L = J_M \times 10$  : Load of high frequent positioning

- L : Length or distance of parts
- N : Motor speed
- $T_L$  : Load torque, total
- v : Moving velocity
- W : Mass (weight)
- $W_1$  : Ditto, movable part
- $W_2$  : Ditto, counter movable part
- $\eta$  : Mechanical efficiency
- $\mu$  : Friction coefficient

(e) Calculation of accel./decel. torque and accel./decel. time (shortest)

(i) Accel./decel. torque

For application to soft start/stop operation, etc, accel./decel. torque should be calculated according to the formula below.

• Accel./decel. torque ( $T_{AC}$ )

$$T_{AC} = \frac{(J_M + J_L) \times 2 \times (N_1 - N_0)}{60 \times (t_{AC})} \pm T_L [N \cdot m]$$

Where,

$J_L$  : Moment of load inertia after conversion into motor shaft [ $kg \cdot m^2$ ]

$J_M$  : Moment of inertia motor rotor [ $kg \cdot m^2$ ]

$N_0$  : Motor speed before the speed change [r/min]

$N_1$  : Speed after the speed change [r/min]

$t_{AC}$  : Accel./decel. time [s]

$T_{AC}$  : Max. accel./decel. (breakdown (max.)) motor torque [ $N \cdot m$ ]

$T_L$  : Load torque after conversion into motor shaft [ $N \cdot m$ ]

The result of the above calculation should be within the allowable maximum accel. /decel. torque of motor.

(ii) Shortest accel./decel. time

For obtaining the target speed in the shortest time, calculation is required by the formula below.

$$t_{AC} = \frac{(J_L + J_M) \times 2 \times (N_1 - N_0)}{60 \times (T_{AC} \pm T_L)} [s]$$

When  $T_{AC} + T_L$  :  $t_{AC}$  : (shortest decel. time)

$T_{AC} - T_L$  :  $t_{AC}$  : (shortest accel. time)

(iii) Operation pattern, basic

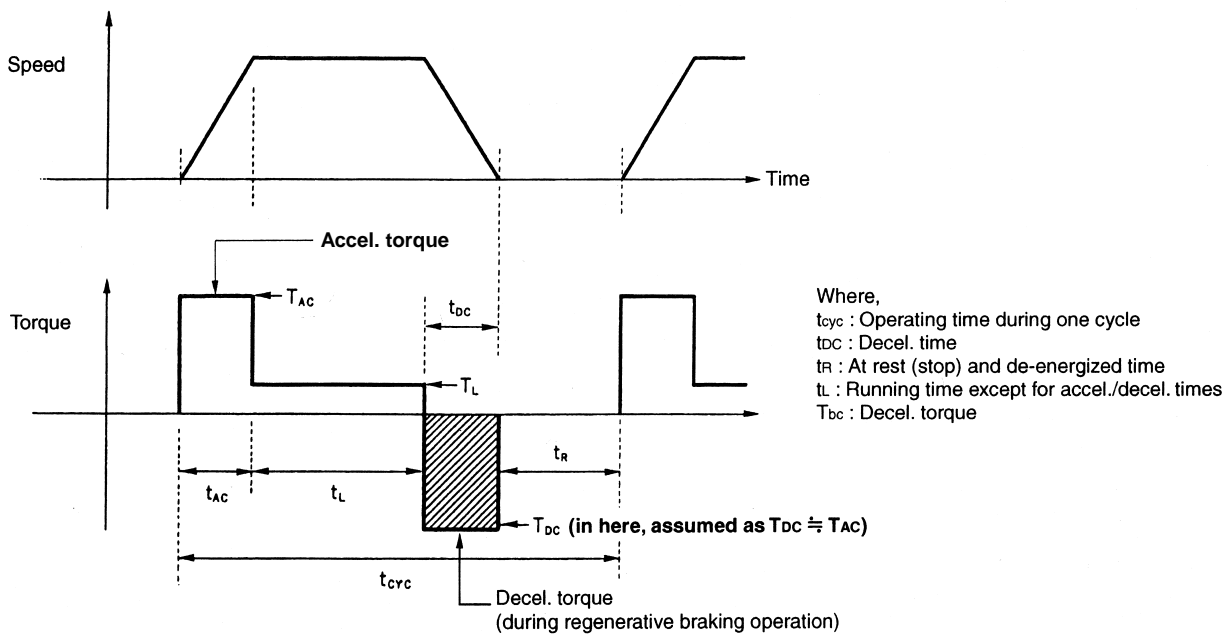

(f) Actual torque ( $T_{rms}$ ) determination

In application to a machine which performs rapid feed frequency, the motor may overheat due to the energy required for accel. and decel.. To prevent this, calculate the actual torque in the following procedure depending on the given repetitive operation pattern and ensure that the value is not larger than motor rated torque.

Shown below are the formula for actual torque in the typical operation pattern.

$$T_{rms} = \sqrt{\frac{(T_{AC}^2 \times t_{AC}) + (T_L^2 \times t_L) + (T_{DC}^2 \times t_{DC})}{t_{cyc}}}$$

If the actual torque surpasses the rated torque, the following items should be reviewed.

- Slightly reduce the frequency of acceleration and deceleration.
- Review decel. method or decel. ratio, etc. and set feed speed appropriately.
- If motor torque is generated even during stop, a mechanical equipment system should be selected so as to minimize the necessity for torque at stop.
- To maintain motor response at a satisfactory level, it is recommended to restrict the moment of load inertia within the twofold value of moment of inertia of motor rotor. If higher frequent operation is absolutely required, the moment of load inertia should be further reduced.

(g) Regenerative braking power

(i) Horizontally moving, deceleration

$$P_1 = 0.105 \times T_{DC} \times N_{10} \times (1/2) [W]$$

Where,

$T_{DC}$  = Decel. torque [ N · m ]

$N_{10}$  = Speed at decel. duration [ r/min ]

(ii) Vertically, lowering

$$P_2 = 0.105 \times T_{L0} \times N_{20} [W]$$

Where,

$T_{L0}$  = Load torque at lowering [ N · m ]

$N_{20}$  = Speed at lowering [ r/min ]

(iii) Mean braking power per cycle

$$P = \frac{P_1 \times t_1 + P_2 \times t_2}{t_{CYC}} [W]$$

Where,

$t_1, t_2$  : Decel. time during  $P_1/P_2$  operation

### (3) Examples of calculation for model type selection

Selection of the output of the motor used for driving the table (horizontally moving body) shown below is exemplified here.

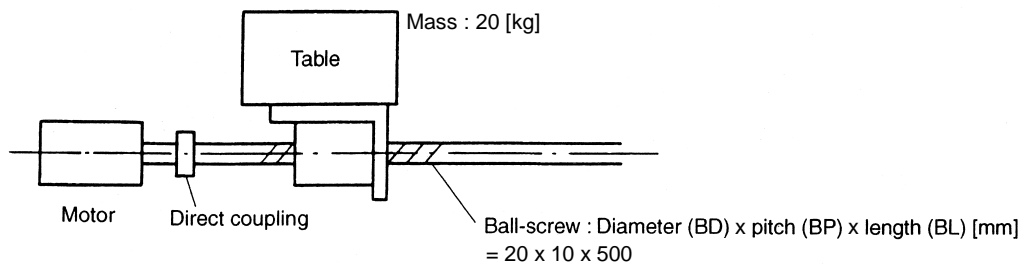

For capacity selection, calculation is required in the following selection procedure.

(i) Moment of inertia of load via conversion into motor shaft

a) Movable part (table) ( $J_{L1}$ )

$$J_{L1} = W \left\{ \frac{1}{2} \times \frac{BP}{10^3} \right\}^2 \times GL^2 = 20 \left\{ \frac{1}{2} \times \frac{10}{10^3} \right\}^2 \times (1/1)^2 = 0.05 \times 10^{-3} [kg \cdot m^2]$$

Where,  $W$  : Mass (weight) of table

b) Ball-screw ( $J_{L2}$ )

$$J_{L2} = \frac{\rho}{32} \times \frac{BL}{10^3} \times \left\{ \frac{BD}{10^3} \right\}^4 \times GL^2 = \frac{7.85 \times 10^3}{32} \times \frac{500}{10^3} \times \left\{ \frac{20}{10^3} \right\}^4 \times (1/1)^2 = 0.06 \times 10^{-3} [kg \cdot m^2]$$

Where,  $\rho$  : Density of ball-screw (assumed as 7850 [kg/m<sup>3</sup>])

thus,  $J_L = J_{L1} + J_{L2} = 0.11 \times 10^{-3} [kg \cdot m^2]$

(ii) Load torque via conversion into motor shaft ( $T_L$ )

$$T_L = \frac{\mu W \times 9.81}{2 \eta} \times \frac{BP}{10^3} \times GL = \frac{0.1 \times 20 \times 9.81}{2 \times 0.9} \times \frac{10}{10^3} \times (1/1) = 0.03 \text{ [N} \cdot \text{m]}$$

Where,  $\mu$  : Friction coefficient = 0.1,  $\eta$  : Mechanical efficiency = 0.9

(iii) Shortest accel./decel. time ( $t_{ac}/t_{dc}$ )

Of the motor which meets the following conditions ;  $J_L \leq 5 \times J_M$  and  $T_L \leq T_R$  (rated torque)  $\times 0.9$   
 0.2 [kW] motor is temporarily selected. :

Where,

$T_L = 0.03 \text{ [N} \cdot \text{m]}$ ,  $J_L = 0.11 \times 10^{-3} \text{ [kg} \cdot \text{m}^2]$ , from motor data according to 2.1 : rated torque = 0.637 [N · m], breakdown (max.) torque = 1.91 [N · m], moment of motor rotor inertia = 0.0216  $\times 10^{-3} \text{ [kg} \cdot \text{m}^2]$  for 0.2 [kW], GYC 201DC1-S motor.

a) Shortest accel./decel. time

$$t_{AC} = \frac{(J_M + J_L) \times 2 \times N}{60(T_{AC} - T_L)} = \frac{(0.0216 \times 10^{-3} + 0.11 \times 10^{-3}) \times 2 \times 3000}{60(1.91 - 0.03)} = 0.022 \text{ [s]}$$

b) Accel./decel. torque for application to soft operation (0.05 [s] accel. time) from 0 to 3000 [r/min] speed

$$T_{AC} = \frac{(J_M + J_L) \times 2 \times N}{60 \times t_{ac}} + T_L = \frac{(0.0216 \times 10^{-3} + 0.11 \times 10^{-3}) \times 2 \times 3000}{60 \times 0.05} + 0.03 = 0.86 \text{ [N} \cdot \text{m]}$$

Where,

$J_M$  : Moment of inertia of motor [kg · m<sup>2</sup>]

$N$  : Motor speed [r/min]

$T_{AC}$  : Max. torque which can be output within an increase from 0 to 3000 [r/min]

(iv) Operation pattern

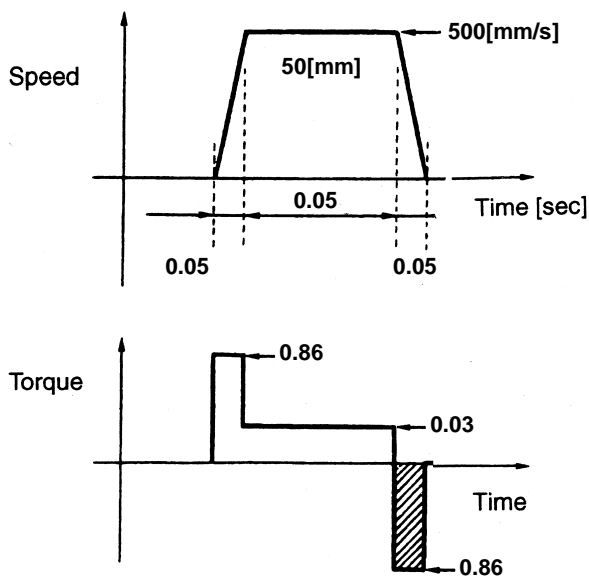

(v) Moving length of ball-screw

Moving velocity ( $v$ ) of mechanical equipment system at 3000 [r/min] motor speed ( $N$ )

$$v = \frac{N}{60} \times BP \times GL = \frac{3000}{60} \times 10 \times (1/1) = 500 \text{ [mm/s]}$$

(vi) Calculation of actual torque ( $T_{rms}$ )

Actual torque can be calculated by the following formula.

$$T_{rms} = \sqrt{\frac{((0.86^2 \times 0.05 \times 2) + (0.03^2 \times 0.05)) \times 1}{0.5}} = 0.38 \text{ [N} \cdot \text{m]}$$

Since the rated torque of 0.2 [kW] motor is 0.637 [N · m], a relation of “actual torque < rated torque “ is satisfied. Therefore, the temporarily selected motor is actually applicable.

(vii) Examination of braking resistor

In the above torque pattern, the hatched area corresponds to the regenerative braking mode. Braking power is as follow.

$$P_1 = 0.105 \times T_{AC} \times N \times (1/2) = 0.105 \times 0.86 \times 3000 \times (1/2) = 135 \text{ [W]}$$

From the above result, mean braking power per cycle is :

$$P = \frac{135 \times 0.05}{0.5} = 14 \text{ [W]}$$

#### (4) Determination of external braking resistor

Because of the braking resistor is not built-in the 0.2 [kW] motor, requiring of external braking resistor provision is reviewed as follows :

(a) Energy ( $E_G$ ) on the mechanical equipment system during deceleration

$$E_G = \frac{1}{2}(J_M + J_L) \cdot (2 \text{ N} / 60)^2$$

$$= \frac{1}{2}(0.0216 \times 10^{-3} + 0.11 \times 10^{-3}) \times \left[ \frac{2 \times 3000}{60} \right]^2 = 6.5 \text{ [J]}$$

(b) Consumption energy ( $E_L$ ) due to load torque

$$E_L = (2 / 60) \times T_L \times N \times t_{DC} \times (1/2)$$

$$= (2 / 60) \times 0.03 \times 3000 \times 0.05 \times (1/2) = 0.24 \text{ [J]}$$

(c) Consumption energy ( $E_M$ ) in motor winding

$$E_M = 3 \times (R \times I^2) \times t_{DC} = 3 \times R \times ((T_{DC} / T_R \times I_R)^2) \times t_{DC}$$

$$= 3 \times 2 \times ((0.86 / 0.637 \times 1.5)^2) \times 0.05 = 1.2 \text{ [J]}$$

(d) Absorbing energy ( $E_S$ ) of motor

$$E_S = \frac{1}{2} CV^2 = \frac{1}{2} (660 \times 10^{-6}) \times (370^2 - (200 \times 2^2)^2) = 18.7 \text{ [J]}$$

Where,

R : Phase resistance of stator winding of GYC201 type motor is 2 [ Ω ], at room temperature

V : Power supply voltage 200 [ V ]

C : DC intermediate capacity of RYS201 amplifier 660 [ μ F ]

(e) Consumption and absorbing energies ( $E_L + E_M + E_S$ ) is 20 [ J ], which is larger than the energy on the mechanical equipment system ( $E_G = 6.5$  [ J ]). Therefore, external braking resistor provision is not required in this example.

## 12.2 Example of program

### (1) Current position output

An example is shown for PLC side program for current position output (see 5.5.4 Current position output).

Connecting the amplifier output terminal to PLC input terminal obtains the current position of motor.

B0 : Obtaining start (input)

B1 : End (input)

B17 : Current position output [CONTn]

B22 : DATA0 [OUT3]

B23 : DATA1 [OUT4]

In the example of program, BD0 to BD12 are used as a working area.

Finally, the current position is stored in the area of BD12 (BCD 7-digit).

Allocate No. 56 (current position output) to control signal of amplifier corresponding to B17 (output).

currentpos - ladder -

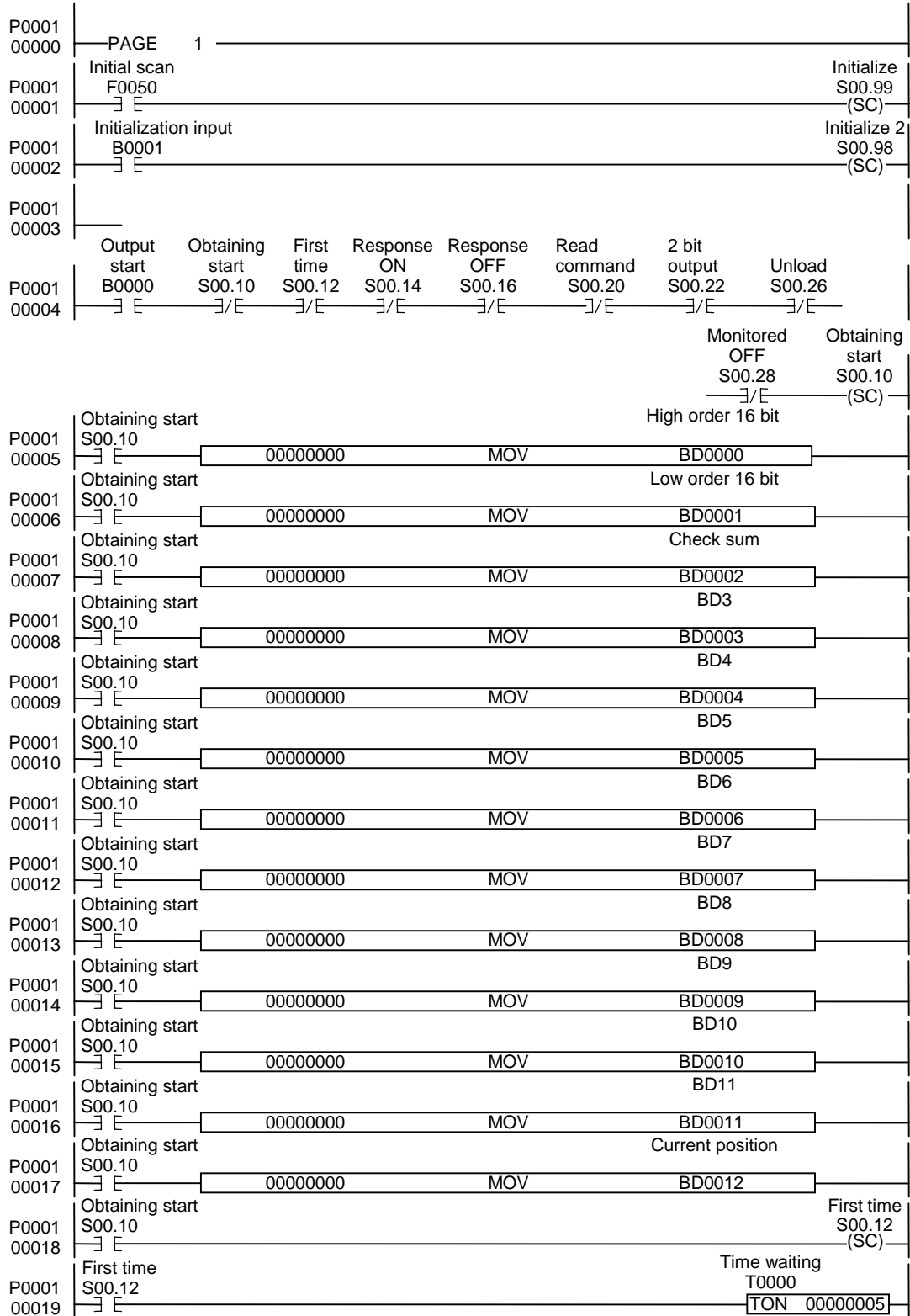

currentpos - ladder -

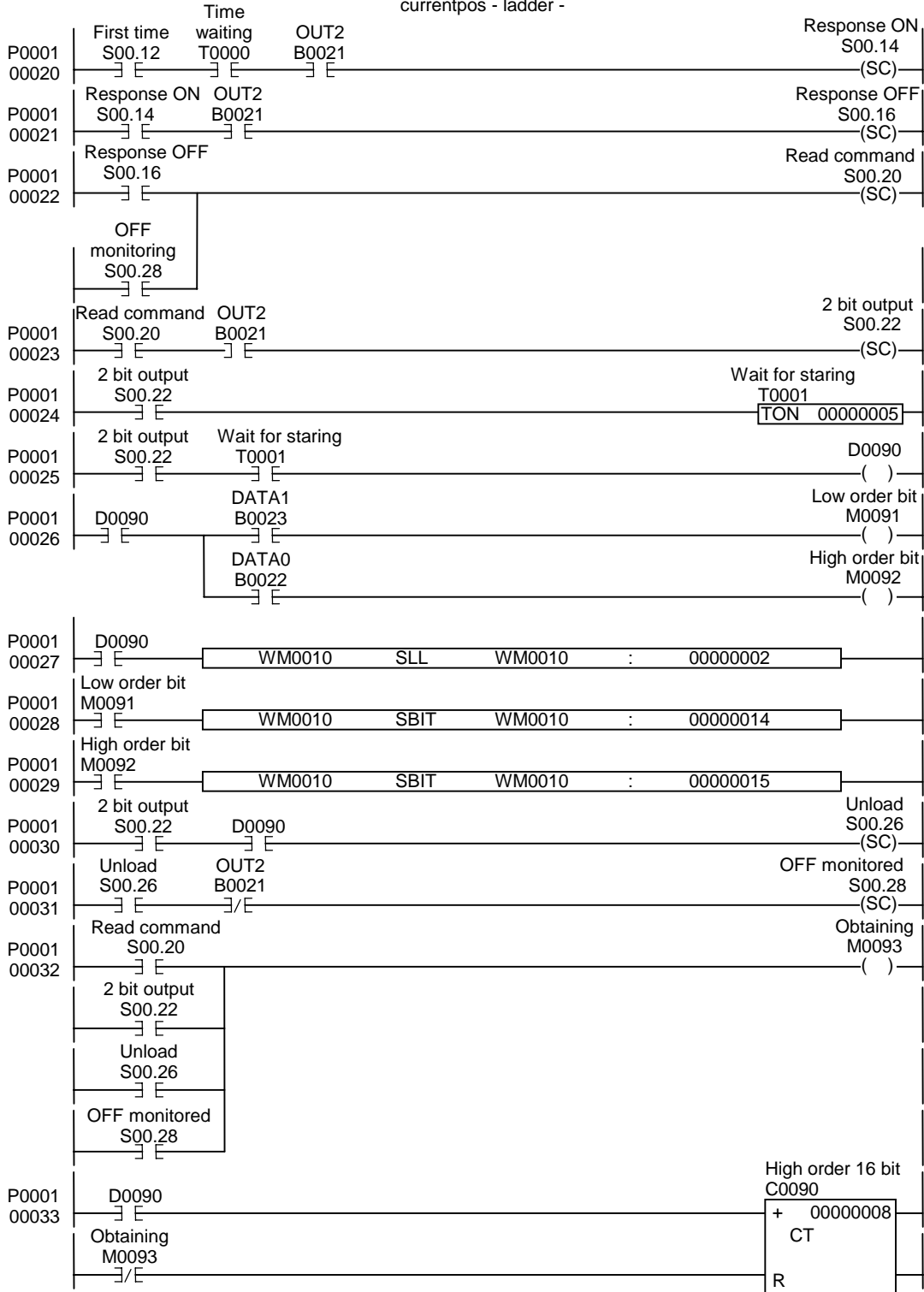

currentpos - ladder -

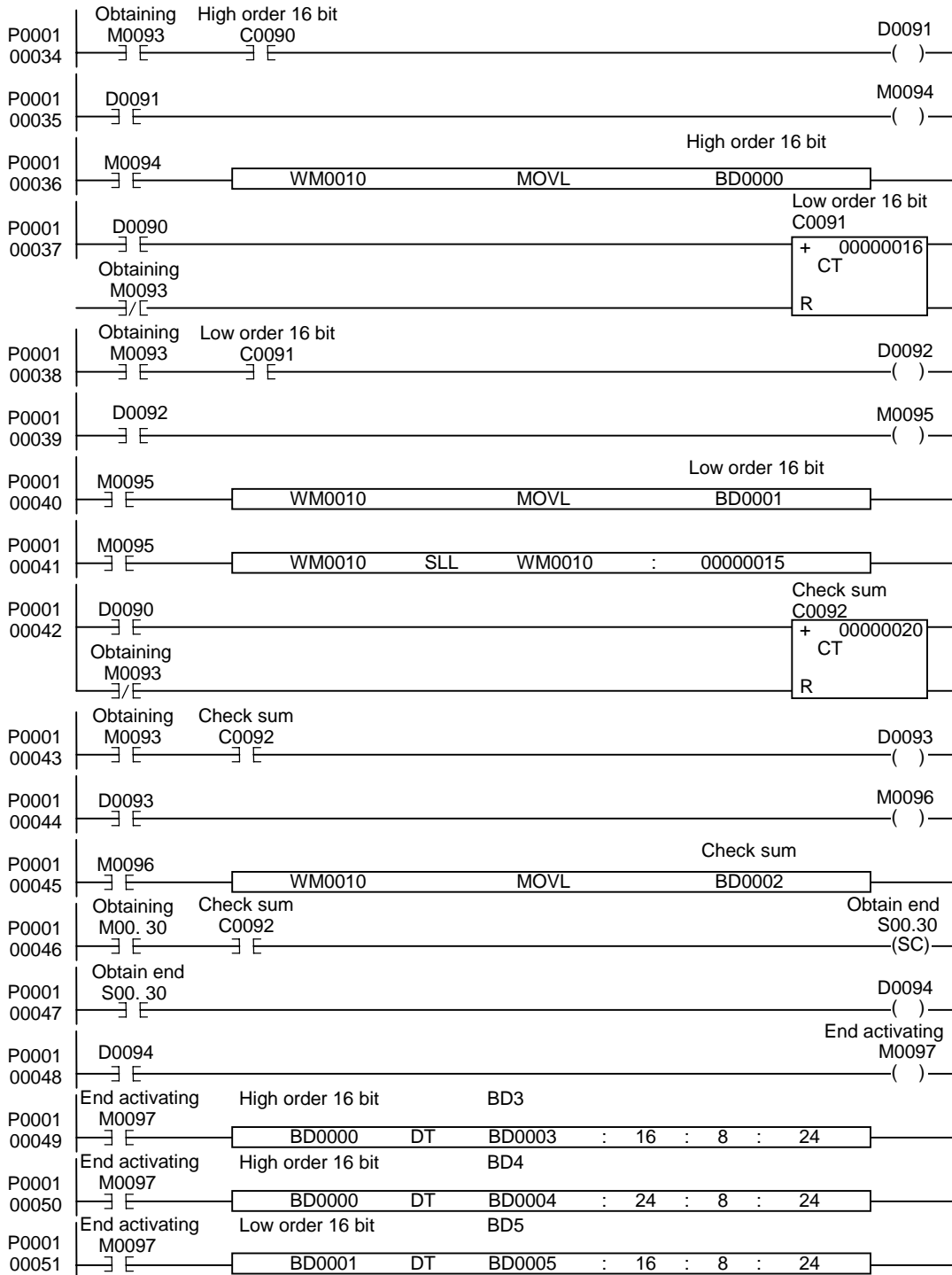

currentpos - ladder -

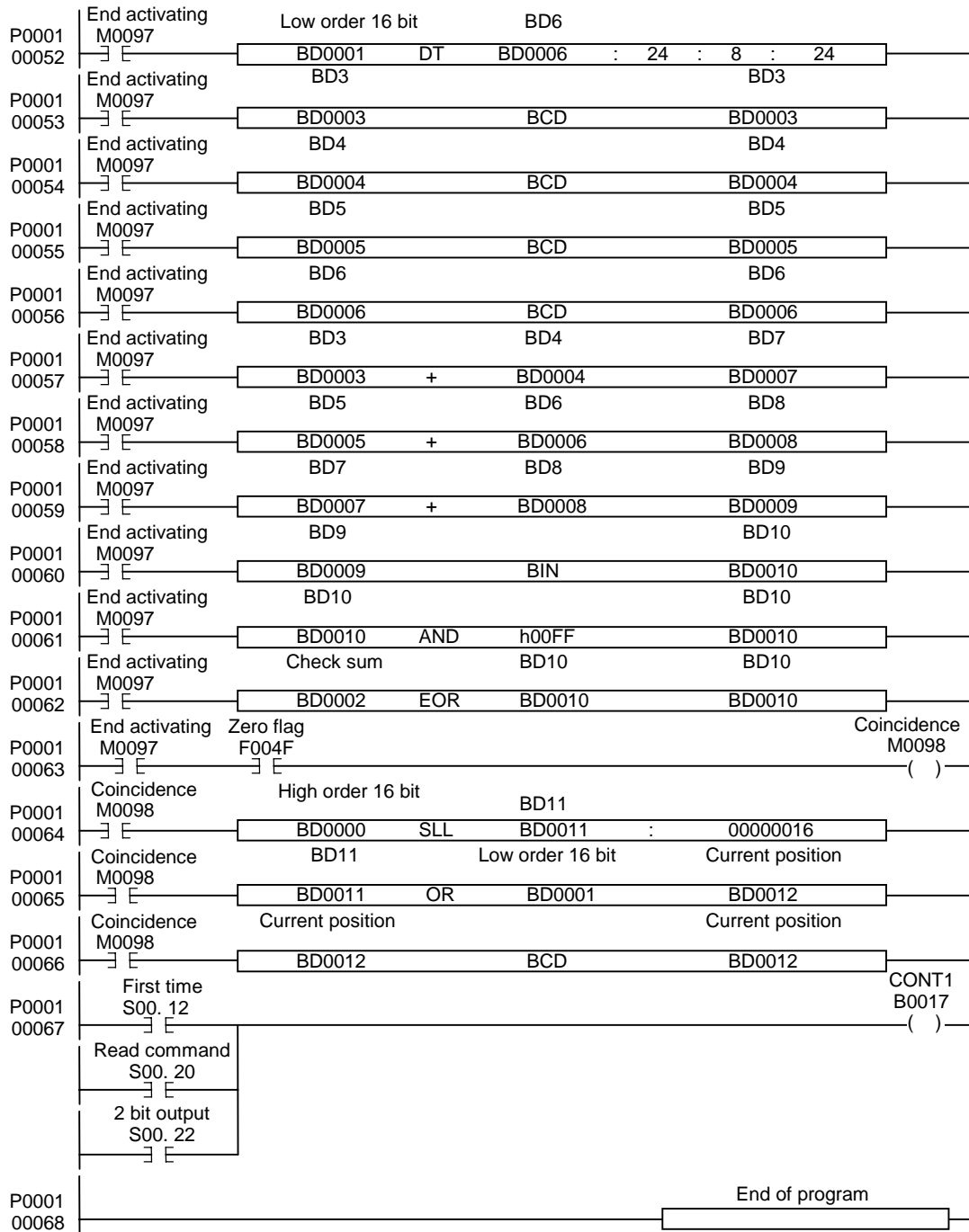

## (2) Current position output

FB (function block) for obtaining a current position output (see 5.5.4 Current position output).

RD\_REQ : Request of current position read [BOOL]  
RD\_ANS : Response of current position read [BOOL]  
ANS\_BIT1 : Amplifier data bit 1 [BOOL]  
ANS\_BIT2 : Amplifier data bit 2 [BOOL]  
RD\_COM : Read command to amplifier [BOOL]  
RD\_RUN : Reading [BOOL]  
RD\_OK : Normal end of reading [BOOL]  
RD\_NG : Abnormal end of reading [BOOL]  
ABS\_POS : Current position data [DINT]

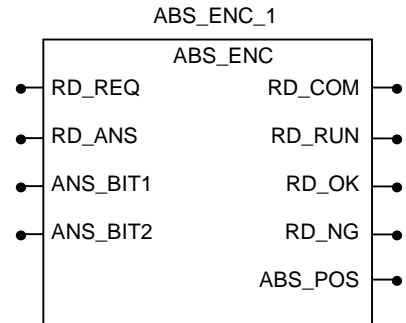

Turning on the RD\_REQ executes a sequence of current position obtain.  
The current position is outputted in [DINT] form to the ABS\_POS terminal.

Connect each terminal to the amplifier.

RD\_COM : Current position output command (control allocate No. 56)  
RD\_ANS : OUT2 of amplifier terminals  
ANS\_BIT1 : OUT3 of amplifier terminals  
ANS\_BIT2 : OUT4 of amplifier terminals

## (3) Immediate positioning

An example is shown for program on PLC for immediate positioning (see 5.5.3 Immediate positioning).  
Connecting the amplifier input terminal to PLC output terminal obtains the stopped position.

B0 : Immediate positioning start (input)	B18: AD7
B1 : Forced end (input)	B19: AD6
B10 : Auto start [CONT6]	B1A: AD5
B11 : Immediate rewrite [CONT9]	B1B: AD4
B12 : Immediate data select 0 [CONT10]	B1C: AD3
B13 : Immediate data select 1 [CONT11]	B1D: AD2
B21 : Positioning end [OUT2]	B1E: AD1
B24 : Rewrite end [OUT5]	B1F: AD0

In the example of program, the value of BCD 8 digit on BD0 is transferred.  
Finally, the auto start [START] signal turn on by FF of address command.  
Allocate the function to B10 to B13, B18 to B1F in the input terminal of amplifier.

POSdirect - ladder -

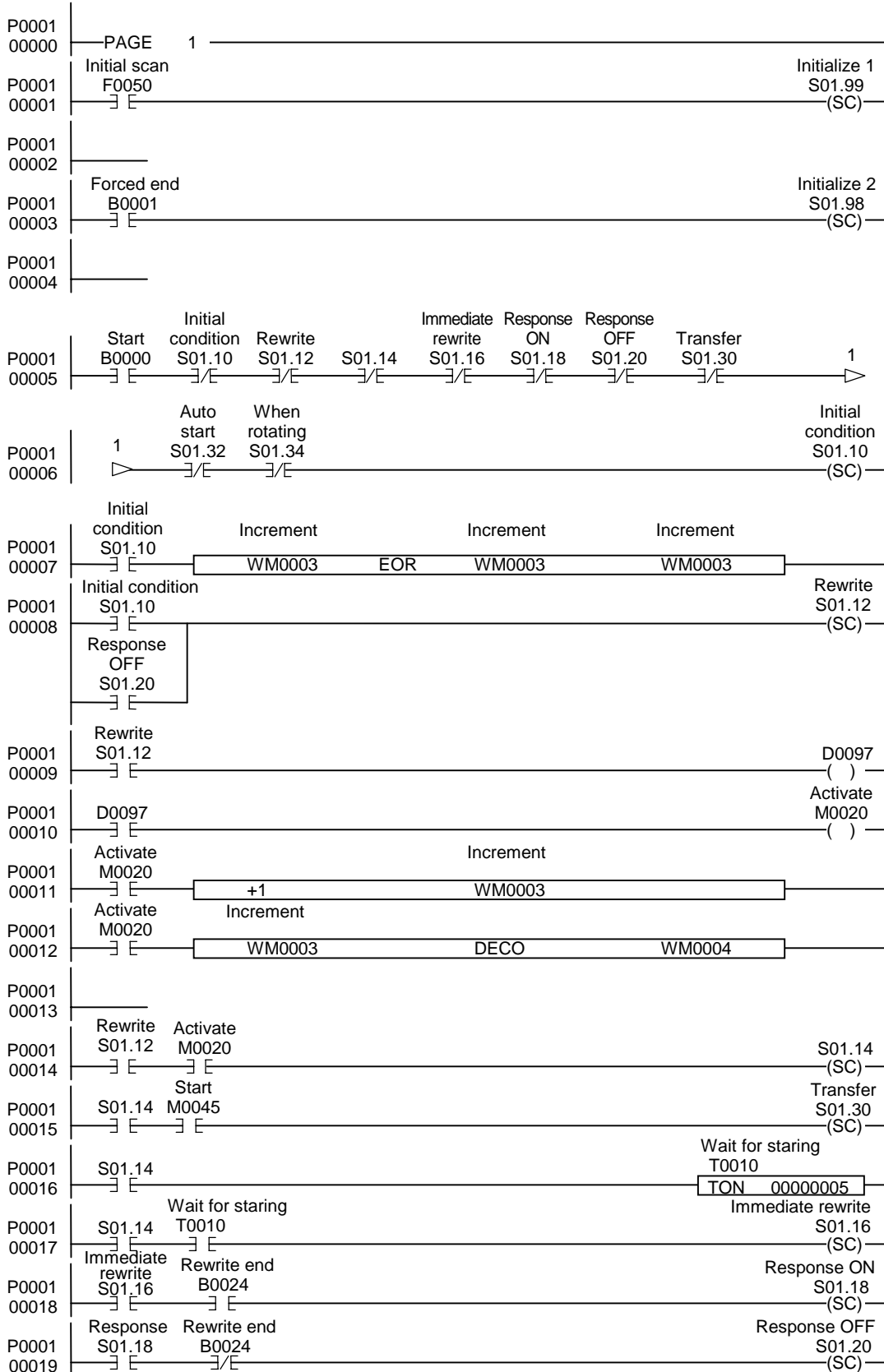

POSdirect - ladder -

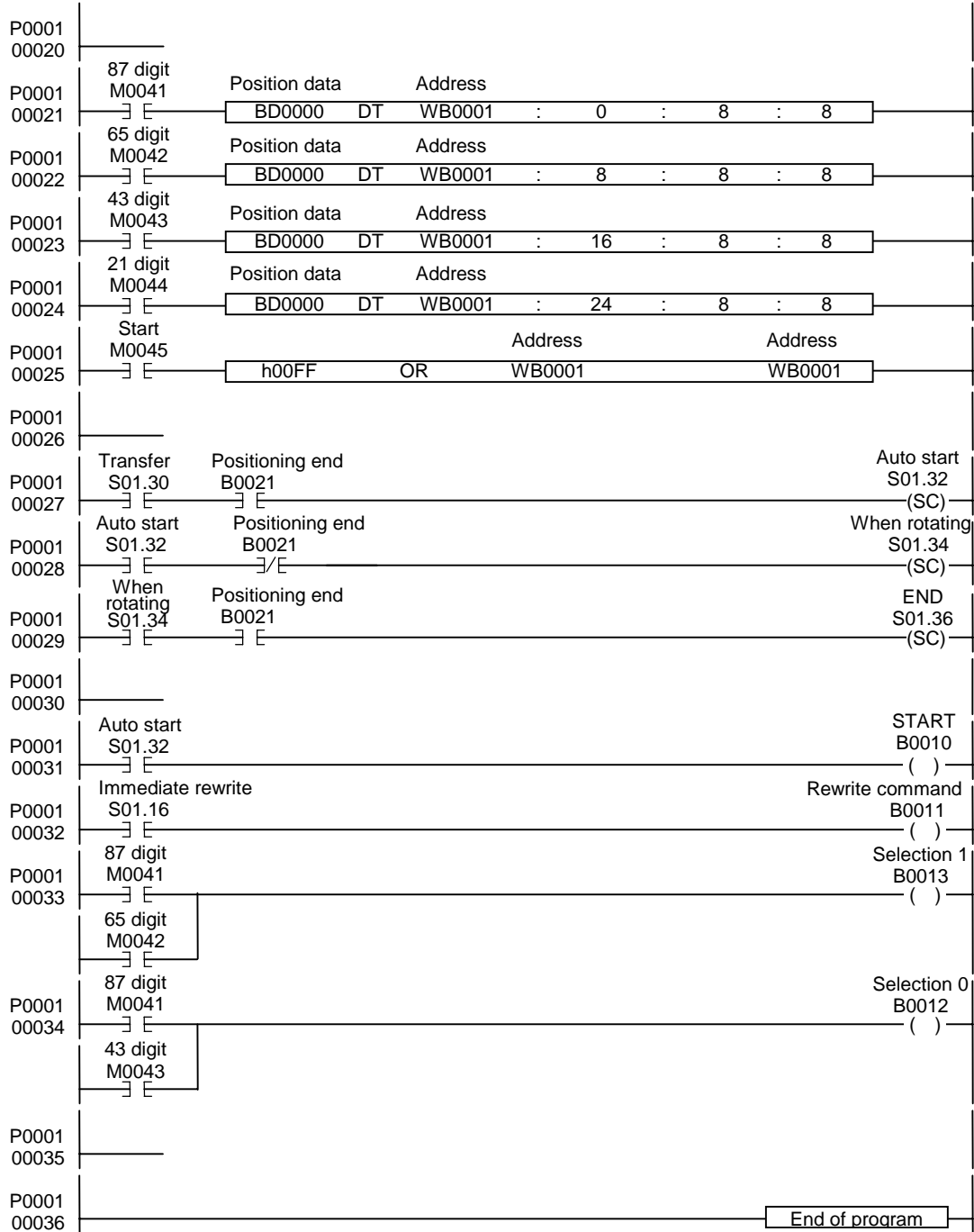

An example of display screen is shown below.

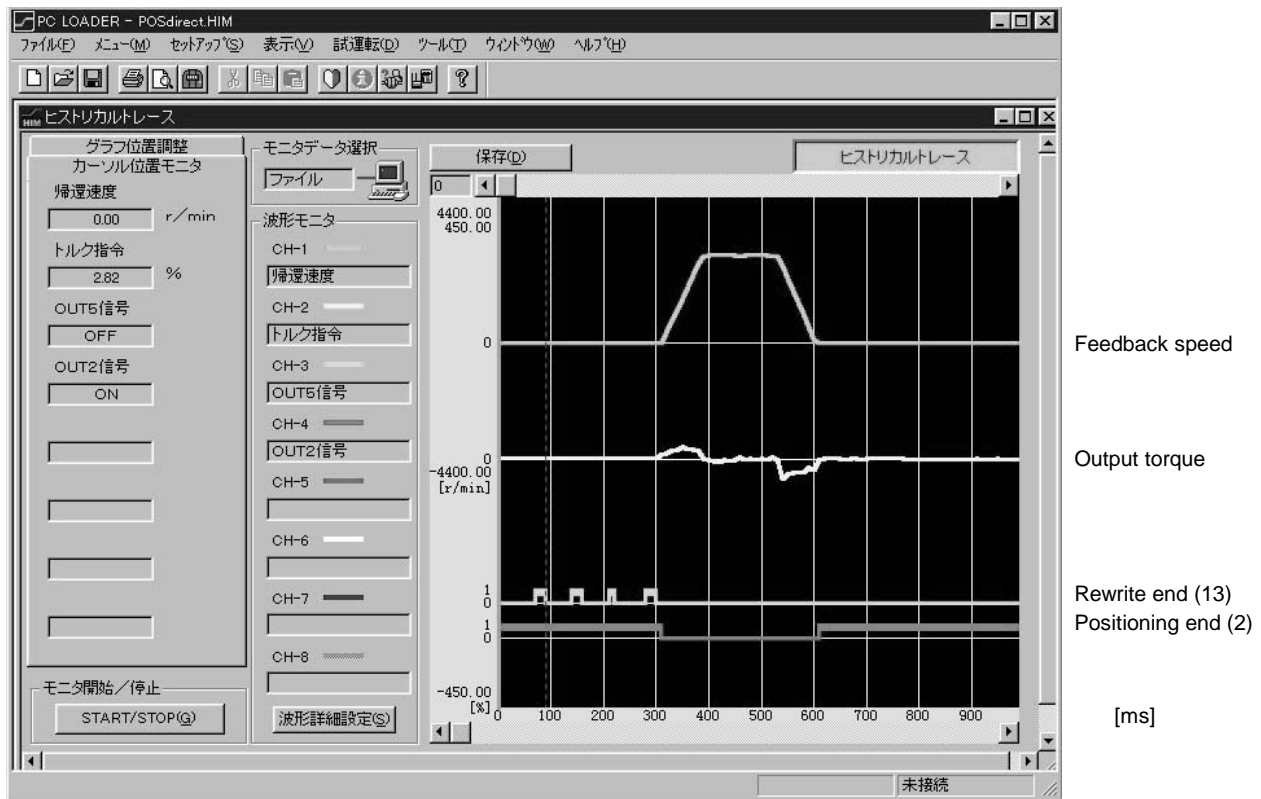

### 12.3 Control block diagram

The control block diagram for RYS-L type amplifier is shown on the next page.

#### (1) Override

Validated by allocating the control assign terminals [CONTn] to signals.

Setting value	No.	Signal name
	43	Override valid
	44	Override 1
	45	Override 2
	46	Override 4
	47	Override 8

#### (2) Manual feed

The speed of manual forward or reverse rotation can be selected by multistep speed selection [X1], [X2] and [X3].

X3	X2	X1	Speed
OFF	OFF	OFF	NREF terminal (speed command voltage)
OFF	OFF	ON	Speed set by speed command [NREF] terminal basic para. 1
OFF	ON	OFF	Speed set by speed command [NREF] terminal basic para. 2
OFF	ON	ON	Speed set by speed command [NREF] terminal basic para. 3
ON	OFF	OFF	Speed set by speed command [NREF] terminal basic para. 4
ON	OFF	ON	Speed set by speed command [NREF] terminal basic para. 5
ON	ON	OFF	Speed set by speed command [NREF] terminal basic para. 6
ON	ON	ON	Speed set by speed command [NREF] terminal basic para. 7



## 12.4 Letter symbols and abbreviated words

<b>A</b>	<p>ABS : Absolute position specified            Accel. : Acceleration            ACCO : Acceleration/deceleration time selection            AD : Address            AF : Absolute data overflow, Multiple rotation data overflow            AH : Amplifier overheat, Amp. heat            AI/AO : Analog input/output            ALM : Alarm detection            Amplifier : Servo-amplifier</p>	<b>F</b>	<p>FAB : Fuji's auto circuit breaker, MCCB            Fb : Fuse blown            FG : Frame (enclosure) ground terminal            FLEX : Fuji's PLC            FLTH, FLTL : Fault-high or -low level            Forward direction : (*)            FWD : Forward command</p>
<b>B</b>	<p>BROUT : Dynamic braking fault output            BX : Free run</p>	<b>H</b>	<p>Hv : Overvoltage, High voltage</p>
<b>C</b>	<p>C : Cleaning key            CA : Command pulse, A-phase            *CA : * is a logic inverted signal of CA            CALL : Read key            CB : Command pulse, B-phase            *CB : * is a logic inverted signal of CB            CCW : Counter-clockwise (*)            CE : Motor combination error            CEND : Cycle end            CH : Controller overheat            CM : Speed monitor, check pin            CMD : Command            CN1 : Control input/output signal connector            CN2 : Encoder (detector) connector            CO : Data continuation            CONT : Control signal            COPY : Copy mode            CPURDY : CPU ready            Ct : Control power trouble (error), Circuit trouble, Amplifier trouble            CtE : Control signal error            CW : Clockwise (*)</p>	<b>I</b>	<p>I/F : Interface            INC : Relative (increment) position specified            INF : Infinite-length feed</p>
<b>D</b>	<p>DB : Internal braking resistor unit            dE : Memory error, Data error            Decel. : Deceleration            DI/DO : Digital input/output            DIR : Shorted route valid            DMON : Data monitor            D No. : Station number</p>	<b>J</b>	<p>JL : Moment of load inertia after conversion into motor shaft            JM : Moment of inertia of motor rotor</p>
<b>E</b>	<p>E : Ground (earth) terminal            EC : Encoder (detector) communication error            EEPROM : Electrically erasable program read only memory            EH : Encoder (detector) overheat, Encoder (detector) heat            ELCB : Earth leakage circuit breaker            EMG : Forced stop            ENQ : Enquiry, control code            EP : Encoder (detector) power error            ERROR : CPU error            Et : Encoder (detector) trouble (error)</p>	<b>L</b>	<p>LC display : Liquid crystal display            LED : Light emitted diode            LS : Origin LS, Origin limit switch            LSD : Least significant digit            Lv : Undervoltage, Low voltage</p>
		<b>M</b>	<p>MAN : Test (trial, manual) mode operation (run)            MC : Magnetic contactor            ME : Memory error            MH : Motor overheat            MICREX : Fuji's PLC            MODE : Transition key            MON1 : Speed monitor            MON2 : Torque monitor            Motor : Servo-motor            MSD : Most significant digit</p>
		<b>N</b>	<p>NARV : Speed arrive            NEXT : Display key of data after (next) one screen (or No.) display            NREF : Speed command            NZERO : Speed zero</p>
		<b>O</b>	<p>OC : Overcurrent, Output overcurrent            OF : Deviation excessive, Overflow            OFF L : Offline key            OL : Motor overload, Overload            ON L : Online key            ORG : Origin return            OS : Overspeed            OT : Overtravel            ± OT : ± direction overtravel            OUT : Out signal            OV : Overvoltage</p>

- P** PA : Parameter editing mode  
 Para. : Parameter  
 PC : Personal computer  
 PC-board : Printed-circuit board  
 P-control : Proportional band control  
 PD : Current (present) position output  
 PE : Main circuit trouble, Power error  
 PG : Encoder detector, Pulse encoder, Pulse generator  
 PLC : Programmable logic controller  
 PMON : Position monitor  
 PO : Positioning data editing mode  
 POWER : Power on  
 PRE : Display key of data before (previous) one screen  
 (or No.) display  
 PSET : Positioning end, Indexing (dividing) end  
 PWRT : Parameter (re)write
- R** RDY : Ready  
 RES : Reset mode  
 REV : Reverse direction  
 Reverse direction : (\*)  
 rH : Braking (DB) resistor overheat, Resistor heat  
 rH2 : Resistor overheat 2, Resistor heat 2  
 RST : Alarm reset  
 RUN : Run command
- S** S-curve : Non-linear  
 SE : System error  
 SEQ : Sequence mode  
 SIGN : Rotational direction  
 SSC : Solid state contactor  
 START : Auto start  
 STOP : Forced stop key  
 STORE : Write-in of numerical setting key  
 SW : Setting switch
- T** tE : Bus communication error, Terminal error  
 TLMT : Torque limit
- U** UV : Undervoltage
- V** VEL : Rotation speed selection
- W** WPSET : Indexing (dividing) end  
 WRT : Position preset, Position data (re)write  
 WRTE : (Re)write end
- X** X1 : Multistep speed selection X1
- 0** 0V : Common monitor, check pin

Note (\*)

Direction of motor shaft rotation (when viewed from a point facing the drive-end of motor) is designed according to Japanese standard :

- Forward direction : Counter-clockwise (CCW) rotation
- Reverse direction : Clockwise (CW) rotation

# Worldwide Operations

## Fuji Service Centers

### Asia and Oceania

#### A/O Service Center, Fuji Electric

11-2, Osaki 1-chome, Shinagawa-ku, Tokyo 141-0032, JAPAN  
Phone : Tokyo 5435-9058  
Facsimile : 03-5435-7525

### America

#### USA Service Center, Fuji Electric

5550 Cerritos Ave., Suite H Cypress, CA 90630 U.S.A.  
Phone : 714-220-1879  
Facsimile : 714-220-1870

### EC, Middle East and Africa

#### EC Service Center, Fuji Electric

Senefelder Str. 1, 63110 Rodgau, F.R. GERMANY  
Phone : 06106-75013  
Facsimile : 06106-72713

### South East Asia

#### South East Asia Service Center, Fuji Electric

Block 5000 Ang Mo Kio Ave. 5 #02-03 SINGAPORE 569870  
Phone : 481-5079  
Facsimile : 481-5476

## Contracted Service Companies

### Asia and Oceania

#### CNC and Robotic Automated Services

20 Hackett Terrace Marryatville, S.A. 5068 AUSTRALIA  
Phone : 08-8378-6081  
Facsimile : 08-8364-4021

#### Fuji-Electric Technology and Service (Shenzhen) Co., Ltd.

Room 209 Liming Bldg. No.144, Zhongxing Rd., Luohu Ku. Shenzhen City, CHINA  
Phone : 0755-220-2745  
Facsimile : 0755-218-5812

#### Fuji Electric (Asia) Co., Ltd.

Room 1001, 10th Fl., Tsimshatsui Center 66 Mody Rd., Tsimshatsui East Kowloon, HONG KONG  
Phone : 2311-8282  
Facsimile : 2312-0566

#### Autonum Controls Pvt. Ltd.

17, Adukia Apartment, S. Mody Rd., Kandivli (West), Mumbai-400 067, INDIA  
Phone : 022-8658136  
Facsimile : 022-8073246

#### Donghai Corporation

Donghai Bldg., 1056-28, Namhyun-dong, Kwanak-ku, Seoul, R.O. KOREA  
Phone : 02-586-0058  
Facsimile : 02-586-0057

#### Gaius Industries Co., Ltd.

2nd Fl., Young Shin Bldg., 954-4, Dogok-dong, Kangnam-gu, Seoul, 135-270, R.O. KOREA  
Phone : 02-554-0766  
Facsimile : 02-554-1118

#### Taiwan Optical Measuring Instrument Co., Ltd.

6th Fl.-3, No.190, Sec. 2, Chung Hsing Rd., Hsin Tien City, Taipei Hsien, TAIWAN R.O.C.  
Phone : 02-29118420  
Facsimile : 02-29189378

### America

#### OESS Corporation

- New Jersey Head Office  
800 Huyler St., Teterboro, NJ 07608, U.S.A.  
Phone : 201-288-4422  
Facsimile : 201-288-4496
- Chicago Office  
4825 N Scott Suite 210, Schiller Park, IL 60126, U.S.A.  
Phone : 847-233-9412  
Facsimile : 847-233-9413
- Los Angeles Office  
5550 Cerritos Ave., Suite H, Cypress, CA 90630, U.S.A.  
Phone : 714-220-1879  
Facsimile : 714-220-1870
- Portland Office  
7921 SW Cirrus Drive, Beaverton, OR 97008, U.S.A.  
Phone : 503-520-5044  
Facsimile : 503-526-0188
- Sunnyvale Office  
1090 E. Arques Ave., Sunnyvale, CA 94086, U.S.A.  
Phone : 408-732-0789  
Facsimile : 408-732-0785

### EC, Middle East and Africa

#### OESS GmbH.

Senefelder Str. 1, 63110 Rodgau, F.R. GERMANY  
Phone : 06106-75013  
Facsimile : 06106-72719

### South East Asia

A. Royal Pte. Ltd.  
Block 5000 Ang Mo Kio Ave. 5 #02-03 SINGAPORE 569870  
Phone : 481-5079  
Facsimile : 481-5476

## Fuji Electric Co.,Ltd.

Gate City Ohsaki, East Tower,  
11-2, Osaki 1-chome, Shinagawa-ku, Tokyo 141-0032, Japan  
Phone : Tokyo 5435-7111  
Telex : J22331 FUJIELEC