



DC SCR DRIVE

SERIES 20H
Line Regenerative
Digital DC SCR Control

Installation & Operating Manual

Table of Contents

Section 1

General Information	1-1
Overview	1-1
Limited Warranty	1-2
Safety Notice	1-3

Section 2

Receiving & Installation	2-1
Receiving & Inspection	2-1
Physical Location	2-1
Optional Remote Keypad Installation	2-2
Control Installation	2-3
Electrical Installation	2-3
System Grounding	2-3
Line Impedance	2-4
Line Reactors	2-4
Wiring Considerations	2-5
AC Main Circuit	2-6
Power Disconnect	2-6
Protection Devices	2-6
Isolation Transformer Sizing	2-6
Single Phase Power	2-6
Connections to an AC Generator Power Source	2-6
Wire Sizes and Protective Devices	2-7
Three Phase Input Power	2-10
Cooling Fan Connection	2-10
Optional Field Power Module	2-10
Motor Connections	2-11
M-Contactor	2-11
External Trip Input	2-13
Encoder Installation	2-13
Home (Orient) Switch Input	2-14
Buffered Encoder Output	2-14
Control Circuit Connections	2-15
Analog Inputs	2-16
Analog Outputs	2-17
Serial Operating Mode	2-18
Keypad Operating Mode	2-18
Standard Run 3 Wire Mode Connections	2-19
15 Speed 2-Wire Operating Mode	2-20
Bipolar Speed or Torque Operating Mode	2-21
Multiple Parameter Sets	2-22
Process Operating Mode	2-23
Bipolar Hoist Mode Connections	2-24
7 Speed Hoist, 2-Wire Mode Connections	2-26

Continued ojn next page

Opto-Isolated Inputs	2-27
Opto-Isolated Outputs	2-28
Pre-Operation Checklist	2-29
Power-Up Procedure	2-29
Section 3	
Programming and Operation	3-1
Overview	3-1
Display Mode	3-2
Adjusting Display Contrast	3-2
Display Mode Screens	3-3
Display Screens & Diagnostic Information Access	3-4
Fault Log Access	3-5
Program Mode	3-6
Parameter Blocks Access for Programming	3-6
Changing Parameter Values when Security Code Not Used	3-7
Reset Parameters to Factory Settings	3-8
Initialize New Firmware	3-9
Operating the Control from the Keypad	3-10
Parameter Definitions	3-13
Section 4	
Troubleshooting	4-1
No Keypad Display - Display Contrast Adjustment	4-1
How to Access the Fault Log	4-2
How to Clear the Fault Log	4-2
How to Access Diagnostic Information	4-3
Control Circuit Board Test Points	4-9
Electrical Noise Considerations	4-10
Special Drive Situations	4-11
Control Enclosures	4-11
Special Motor Considerations	4-11
Analog Signal Wires	4-11
Wiring Practices	4-12
Plant Ground	4-12

Section 5	
Specifications and Product Data	5-1
Specifications	5-1
Operating Conditions	5-1
Keypad Display	5-2
Control Specifications	5-2
Field Power Supply	5-3
Differential Analog Input	5-3
Analog Outputs	5-3
Digital Inputs	5-4
Digital Outputs	5-4
Diagnostic Indications	5-4
Ratings	5-5
Torque Specifications	5-6
Inter-connect Diagram	5-7
Dimensions	5-8
Size A Control	5-8
Size B Control	5-9
Size C Control	5-10
Size D Control	5-11
Size G Control	5-12
Appendix A	A-1
Field Supply Module	A-1
Appendix B	B-1
Parameter Values	B-1
Appendix C	C-1
Remote Keypad Mounting Template	C-2

Section 1

General Information

Overview

The Baldor Series 20H control is a three phase, full wave, bi-directional DC motor armature and field (where applicable) control. The SCR bridge converts three phase AC power to controlled DC to operate the DC motor armature. The AC input is also used for the reference transformer input to operate power supplies and synchronize to the AC input line. The firing pulses are supplied to the SCR gates through the pulse amplifiers and transformers. This control is of the NEMA Type C designation.

The Baldor Series 20H control may also be used with permanent magnet field motors and DC spindle drive motors. In addition, the Baldor Series 20H control may be used with standard feedback from armature or encoder. Tachometer or resolver feedback is available with optional expansion boards.

The Baldor Series 20H control may be used in many different applications. It can be configured to operate in a number of modes depending upon the application requirements and user preference.

It is the responsibility of the user to determine the correct operating mode to use for the application. These choices are made using the keypad as explained in Section 3 of this manual.

⚠ Caution: **The Baldor Series 20H DC SCR Control is not designed for regenerative use for stabilized shunt or compound wound motors. If stabilized shunt or compound wound are to be used, the series field must be isolated and not connected. Contact the motor manufacturer for motor derating specifications under these conditions.**

Limited Warranty

For a period of two (2) years from the date of original purchase, BALDOR will repair or replace without charge controls and accessories which our examination proves to be defective in material or workmanship. This warranty is valid if the unit has not been tampered with by unauthorized persons, misused, abused, or improperly installed and has been used in accordance with the instructions and/or ratings supplied. This warranty is in lieu of any other warranty or guarantee expressed or implied. BALDOR shall not be held responsible for any expense (including installation and removal), inconvenience, or consequential damage, including injury to any person or property caused by items of our manufacture or sale. (Some states do not allow exclusion or limitation of incidental or consequential damages, so the above exclusion may not apply.) In any event, BALDOR's total liability, under all circumstances, shall not exceed the full purchase price of the control. Claims for purchase price refunds, repairs, or replacements must be referred to BALDOR with all pertinent data as to the defect, the date purchased, the task performed by the control, and the problem encountered. No liability is assumed for expendable items such as fuses.

Goods may be returned only with written notification including a BALDOR Return Authorization Number and any return shipments must be prepaid.

Safety Notice

This equipment contains voltages that may be as high as 600 volts! Electrical shock can cause serious or fatal injury. Only qualified personnel should attempt the start-up procedure or troubleshoot this equipment.

This equipment may be connected to other machines that have rotating parts or parts that are driven by this equipment. Improper use can cause serious or fatal injury. Only qualified personnel should attempt the start-up procedure or troubleshoot this equipment.

PRECAUTIONS

- ⚠ WARNING:** Do not touch any circuit board, power device or electrical connection before you first ensure that power has been disconnected and there is no high voltage present from this equipment or other equipment to which it is connected. Electrical shock can cause serious or fatal injury. Only qualified personnel should attempt the start-up procedure or troubleshoot this equipment.
- ⚠ WARNING:** This unit has an automatic restart feature that will start the motor whenever input power is applied and a RUN (FWD or REV) command is issued. If an automatic restart of the motor could cause injury to personnel, the automatic restart feature should be disabled by changing the Level 2 Miscellaneous block, Restart Auto/Man parameter to Manual.
- ⚠ WARNING:** Be sure that you are completely familiar with the safe operation of this equipment. This equipment may be connected to other machines that have rotating parts or parts that are controlled by this equipment. Improper use can cause serious or fatal injury. Only qualified personnel should attempt the start-up procedure or troubleshoot this equipment.
- ⚠ WARNING:** Be sure the system is properly grounded before applying power. Do not apply AC power before you ensure that all grounding instructions have been followed. Electrical shock can cause serious or fatal injury.
- ⚠ WARNING:** Improper operation of control may cause violent motion of the motor shaft and driven equipment. Be certain that unexpected motor shaft movement will not cause injury to personnel or damage to equipment. Certain failure modes of the control can produce peak torque of several times the rated motor torque.
- ⚠ WARNING:** Motor circuit may have high voltage present whenever AC power is applied, even when motor is not rotating. Electrical shock can cause serious or fatal injury.
- ⚠ WARNING:** The motor shaft will rotate during the autotune procedure. Be certain that unexpected motor shaft movement will not cause injury to personnel or damage to equipment.

Continued on next page

⚠ Caution: Over-current protection is required by the National Electrical Code. The installer of this equipment is responsible for complying with the National Electrical Code and any applicable local codes which govern such practices as wiring protection, grounding, disconnects, and other current protection.

⚠ Caution: Suitable for use on a circuit capable of delivering not more than the RMS symmetrical short circuit amperes listed here at rated voltage.

<u>Horsepower</u>	<u>rms Symmetrical Amperes</u>
1-50	5,000
51-200	10,000
201-400	18,000
401-600	30,000
601-900	42,000

⚠ Caution: Do not supply any power to the External Trip input at J1-16 and 17. Power on these leads can damage the control. Use a dry contact type that requires no external power to operate.

⚠ Caution: Do not use power factor correction capacitors on the input power lines to the control or damage to the control may result.

⚠ Caution: Do not install capacitors across the A1/A2 armature terminals or SCR failure may result.

⚠ Caution: Disconnect motor leads (A1 and A2) from control before you perform a “Megger” test on the motor. Failure to disconnect motor from the control will result in extensive damage to the control. The control is tested at the factory for high voltage / leakage resistance as part of Underwriter Laboratory requirements.

⚠ Caution: Do not connect AC power to the Motor terminals A1 and A2. Connecting AC power to these terminals may result in damage to the control.

⚠ Caution: Baldor recommends not using “Grounded Leg Delta” transformer power leads that may create ground loops and degrade system performance. Instead, we recommend using a four wire Wye.

Section 2 Receiving & Installation

Receiving & Inspection

The Series 20H DC SCR Control is thoroughly tested at the factory and carefully packaged for shipment. When you receive your control, there are several things you should do immediately.

1. Observe the condition of the shipping container and report any damage immediately to the commercial carrier that delivered your control.
2. Verify that the part number of the control you received is the same as the part number listed on your purchase order.
3. If the control is to be stored for several weeks before use, be sure that it is stored in a location that conforms to published storage specifications. (Refer to Section 5 of this manual).

Physical Location

The location of the 20H is important. It should be installed in an area that is protected from direct sunlight, corrosives, harmful gases or liquids, dust, metallic particles, and vibration. Exposure to these elements can reduce the operating life and degrade performance of the control.

Several other factors should be carefully evaluated when selecting a location for installation:

1. For effective cooling and maintenance, the control should be mounted vertically on a flat, smooth, non-flammable vertical surface. When the control is mounted in an enclosure, use the watts loss information of Table 2-1 to provide proper cooling and ventilation (4 watts per continuous output ampere).
2. At least two inches clearance must be provided on all sides for air flow.
3. Front access must be provided to allow the control cover to be opened or removed for service and to allow viewing of the Keypad Display. (The keypad may optionally be remote mounted up to 100 feet from the control.)
Controls installed in a floor mounted enclosure must be positioned with clearance to open the enclosure door. This clearance will also provide sufficient air space for cooling.
4. **Altitude derating.** Up to 3300 feet (1000 meters) no derating required. Above 3300 ft, derate the continuous and peak output current by 2% for each 1000 ft.
5. **Temperature derating.** Up to 40°C no derating required. Above 40°C, derate the continuous and peak output current by 2% per °C. Maximum ambient is 55°C.

Shock Mounting

If the control will be subjected to levels of shock greater than 1G or vibration greater than 0.5G at 10 to 60Hz, the control should be shock mounted. Excessive vibration within the control could cause internal connections to loosen and cause component failure or electrical shock hazard.

Table 2-1 Series 20H Watts Loss Ratings (4 Watts per Amp)

Catalog No.	DC Current	Watts Loss	Catalog No.	DC Current	Watts Loss	Catalog No.	DC Current	Watts Loss
BC20H103-CL	20	80	BC20H205-CL	20	80	BC20H410-CL	20	80
BC20H107-CL	40	160	BC20H210-CL	40	160	BC20H420-CL	40	160
BC20H110-CL	60	240	BC20H215-CL	60	240	BC20H430-CL	60	240
BC20H115-CL	75	300	BC20H220-CL	75	300	BC20H440-CL	75	300
BC20H120-CL	100	400	BC20H225-CL	100	400	BC20H450-CL	100	400
BC20H125-CL	140	560	BC20H240-CL	140	560	BC20H475-CL	140	560
BC20H135-CL	180	720	BC20H250-CL	180	720	BC20H4100-CL	180	720
BC20H140-CL	210	840	BC20H260-CL	210	840	BC20H4125-CL	210	840
BC20H150-CL	270	1080	BC20H275-CL	270	1080	BC20H4150-CL	270	1080
			BC20H2125-CL	420	1680	BC20H4200-CL	350	1400
						BC20H4250-CL	420	1680
						BC20H4300-CL	500	2000
						BC20H4400-EL	670	2680
						BC20H4500-EL	840	3360
						BC20H4600-EL	960	3840

Optional Remote Keypad Installation The keypad may be remotely mounted using the optional Baldor keypad extension cable. The keypad assembly (white - DC00005A-01; grey - DC00005A-02) comes complete with the screws and gasket required to mount it to an enclosure. When the keypad is properly mounted to a NEMA Type 4X enclosure, it retains the Type 4X rating.

Tools Required:

- Center punch, tap handle, screwdrivers (Phillips and straight) and crescent wrench.
- 8-32 tap and #29 drill bit (for tapped mounting holes) or #19 drill (for clearance mounting holes).
- 1-1/4" standard knockout punch (1-11/16" nominal diameter).
- RTV sealant.
- (4) 8-32 nuts and lock washers.
- Extended 8-32 screws (socket fillister) are required if the mounting surface is thicker than 12 gauge and is not tapped (clearance mounting holes).
- Remote keypad mounting template. A tear out copy is provided at the end of this manual for your convenience.

Mounting Instructions: For tapped mounting holes

1. Locate a flat 4" wide x 5.5" minimum high mounting surface. Material should be sufficient thickness (14 gauge minimum).
2. Place the template on the mounting surface or mark the holes as shown.
3. Accurately center punch the 4 mounting holes (marked A) and the large knockout (marked B).
4. Drill four #29 mounting holes (A). Thread each hole using an 8-32 tap.
5. Locate the 1-1/4" knockout center (B) and punch using the manufacturers instructions.
6. Debur knockout and mounting holes making sure the panel stays clean and flat.
7. Apply RTV to the 4 holes marked (A).
8. Assemble the keypad to the panel. Use 8-32 screws, nuts and lock washers.
9. From the inside of the panel, apply RTV over each of the four mounting screws and nuts. Cover a 3/4" area around each screw while making sure to completely encapsulate the nut and washer.

Mounting Instructions: For clearance mounting holes

1. Locate a flat 4" wide x 5.5" minimum high mounting surface. Material should be sufficient thickness (14 gauge minimum).
2. Place the template on the mounting surface or mark the holes as shown on the template.
3. Accurately center punch the 4 mounting holes (marked A) and the large knockout (marked B).
4. Drill four #19 clearance holes (A).
5. Locate the 1-1/4" knockout center (B) and punch using the manufacturers instructions.
6. Debur knockout and mounting holes making sure the panel stays clean and flat.
7. Apply RTV to the 4 holes marked (A).
8. Assemble the keypad to the panel. Use 8-32 screws, nuts and lock washers.
9. From the inside of the panel, apply RTV over each of the four mounting screws and nuts. Cover a 3/4" area around each screw while making sure to completely encapsulate the nut and washer.

Control Installation

The control must be securely fastened to the mounting surface. Refer to Section 5 for mounting dimensions and mounting hole location.

Shock Mounting

If the control will be subjected to levels of vibration greater than 0.5G at 10 to 60Hz, the control should be shock mounted.

Electrical Installation

Interconnection wiring is required between the DC SCR control, AC power source, motor, host control and any operator interface stations. Use listed closed loop connectors that are of appropriate size for wire gauge being used. Connectors are to be installed using crimp tool specified by the manufacturer of the connector. Only Class 1 wiring should be used.

Baldor Series 20H controls feature UL approved adjustable motor overload protection suitable for motors rated at no less than 50% of the output rating of the control. Other governing agencies such as NEC may require separate over-current protection. The installer of this equipment is responsible for complying with the National Electric Code and any applicable local codes which govern such practices as wiring protection, grounding, disconnects and other current protection.

System Grounding

Baldor Controls are designed to be powered from standard three phase lines that are electrically symmetrical with respect to ground. System grounding is an important step in the overall installation to prevent problems. The recommended grounding method is shown in Figure 2-1.

Figure 2-1 Recommended System Grounding

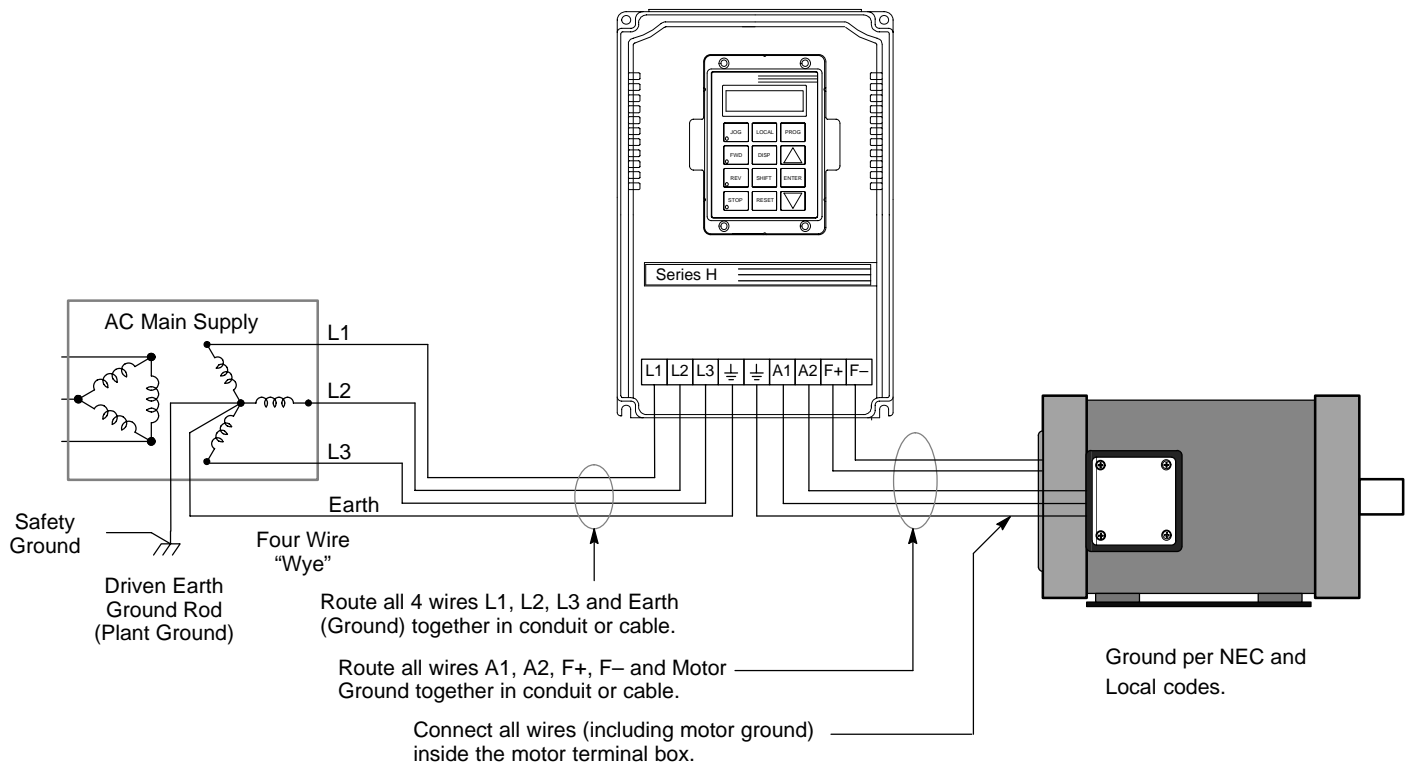

Ungrounded Distribution System

With an ungrounded power distribution system it is possible to have a continuous current path to ground through the MOV devices. To avoid equipment damage, an Isolation transformer with a grounded secondary is recommended. This provides three phase AC power that is symmetrical with respect ground.

Input Power Conditioning

Baldor controls are designed for direct connection to standard three phase lines that are electrically symmetrical with respect to ground. Certain power line conditions must be avoided. An AC line reactor or an isolation transformer may be required for some power conditions.

- Baldor Series H controls require a maximum line impedance of 5%. Refer to “Line Impedance” for additional information.
- If the feeder or branch circuit that provides power to the control has permanently connected power factor correction capacitors, an input AC line reactor or an isolation transformer must be connected between the power factor correction capacitors and the control.
- If the feeder or branch circuit that provides power to the control has power factor correction capacitors that are switched on line and off line, the capacitors must not be switched while the control is connected to the AC power line. If the capacitors are switched on line while the control is still connected to the AC power line, additional protection is required. TVSS (Transient Voltage Surge Suppressor) of the proper rating must be installed between the AC line reactor or an isolation transformer and the AC input to the control.

Line Impedance

The Baldor Series 20H control requires a 5% maximum line impedance (voltage drop across the reactor is 5% when the control draws rated input current). If the impedance of the incoming power does not meet the requirement for the control, a 3 phase line reactor can be used to provide the needed impedance in most cases. Line reactors are optional and are available from Baldor.

The input impedance of the power lines can be determined as follows:

Measure the line to line voltage at no load and at full rated load.
Use these measured values to calculate impedance as follows:

$$\% \text{Impedance} = \frac{(\text{Volts}_{\text{No Load Speed}} - \text{Volts}_{\text{Full Load Speed}})}{(\text{Volts}_{\text{No Load Speed}})} \times 100$$

Line Reactors

Three phase line reactors are available from Baldor. The line reactor to order is based on the full load current of the motor (FLA). If providing your own line reactor, use the following formula to calculate the minimum inductance required.

$$L = \frac{(V_{L-L} \times 0.03)}{(I \times \sqrt{3} \times 377)}$$

- Where:
- L Minimum inductance in Henries.
 - V_{L-L} Input volts measured line to line.
 - 0.03 Desired percentage of input impedance.
 - I Input current rating of control.
 - 377 Constant used with 60Hz power.
Use 314 if input power is 50Hz.

Wiring Considerations

The DC control is self protected from normal AC line transients and surges. Additional external protection may be required if high energy transients are present on the incoming power source. These transients could be caused by sharing a power source with arc welding equipment, large motors being started across the line, or other industrial equipment requiring large surge currents. To prevent damage due to power source disturbances the following should be considered:

- a) Connect the control on a feeder line separate from those supplying large inductive loads.
- b) Supply power to the control through a suitably sized isolation transformer. When using an isolation transformer to power the control, always switch the power off and on between the transformer secondary and the control input to avoid spikes at the control when power is removed from the primary side.

All external signal wiring to the DC control should be run in a separate conduit from all other wiring. The use of shielded twisted pair wire is recommended for all signal wiring. The shield of the control wiring should be connected to analog ground of the DC control only. The other end of the shield should be taped to the wire jacket to prevent electrical shorts.

Wires for motor armature and fields may be run together in a conduit in accordance with NEC and local electrical codes and practices. For more information on wiring considerations, refer to "Electrical Noise Considerations" in Section 4 of this manual.

AC Main Circuit

Power Disconnect

A power disconnect should be installed between the input power service and the control for a fail safe method to disconnect power. The control will remain in a powered-up condition until all input power is removed from the control and the internal bus voltage is depleted.

Protection Devices

Be sure a suitable input power protection device is installed. Use the recommended circuit breaker or fuses listed in Tables 2-3 through 2-5 (Wire Size and Protection Devices). Refer to ratings in Section 5 of this manual. If the output power from the control will be less than the maximum, the sizes of the wire and protective devices may be adjusted accordingly. Be sure to follow NEC, UL and other applicable codes. Input and output wire size is based on the use of copper conductor wire rated at 75 °C. The table is specified for NEMA B motors.

Circuit Breaker:	1 phase, thermal magnetic. Equal to GE type THQ or TEB for 230 VAC 3 phase, thermal magnetic. Equal to GE type THQ or TEB for 230 VAC or GE type TED for 460 VAC and 575 VAC.
Fast Action Fuses:	230 VAC, Buss KTN 460 VAC, Buss KTS to 600A (KTU 601 - 1200A) 575VAC, Buss FRS
Very Fast Action:	230 VAC, Buss JJN 460 VAC, Buss JJS 575 VAC, Buss JJS
Time Delay Fuses:	230 VAC, Buss FRN 460 VAC, Buss FRS to 600A (KTU 601 - 1200A) 575 VAC, Buss FRS to 600A (KLU 601 - 1200A)

Recommended fuse sizes are based on the following:

115% of maximum continuous current for time delay fuses.

150% of maximum continuous current for fast or very fast acting fuses.

Isolation Transformer Sizing

Use the information in Table 2-2 to select the KVA rating of the transformer based on the HP rating of the control. The secondary voltage will be the input voltage to the control and the impedance should be 5% or less.

One exception to Table 2-2 is when the DC armature voltage is less than the AC input voltage. If this is the case, use the following formula:

$$\text{KVA} = 0.00163 \times \text{VAC}_{\text{Secondary}} \times \text{IDC}_{\text{Secondary}}$$

Table 2-2 Isolation Transformer KVA Selection

HP	5	7.5	10	15	20	25	30	40	50	60	75	100	125	150	200	250	300
KVA	7.5	11	14	20	27	34	40	51	63	75	93	118	145	175	220	275	330

Single Phase Power

Since the control rectifies all three input power phases, operation from a single phase power source is not possible.

Connections to an AC Generator Power Source

If a three phase motor driven generator set is to be used as the AC power source for the Baldor Control, the KVA rating of the generator should be at least 20 times the KVA rating of the control.

Wire Sizes and Protective Devices

Table 2-3 Recommended Wire Size – 115VAC

Catalog Number	Input Amp	Maximum Output		Fuse		Wire Size					
		HP	KW	Armature & AC Input	Buss Type	AC Input		Armature Output		Field Power Supply	
						AWG	MM ²	AWG	MM ²	AWG	MM ²
BC20H103-CL	16	3	2.2	50A, 500V	FWH-50A	10	6	10	6	14	2.5
BC20H107-CL	33	7	5.2	80A, 500V	FWH-80A	6	16	6	16	14	2.5
BC20H110-CL	49	10	7.5	100A, 500V	FWH-100A	4	25	3	30	14	2.5
BC20H115-CL	62	15	11.2	150A, 500V	FWH-150A	3	30	2	35	14	2.5
BC20H120-CL	82	20	14.9	150A, 500V	FWH-150A	1	50	1/0	54	14	2.5
BC20H125-CL	115	25	18.6	300A, 500V	FWH-300A	1/0	54	2/0	70	14	2.5
BC20H135-CL	148	35	26	350A, 500V	FWH-350A	3/0	95	4/0	120	14	2.5
BC20H140-CL	172	40	29.8	400A, 500V	FWH-400A	4/0	120	300MCM	150	14	2.5
BC20H150-CL	221	50	37.3	450A, 500V	FWH-450A	300MCM	150	500MCM	240	14	2.5

Table 2-4 Recommended Wire Size – 230VAC

Catalog Number	Input Amp	Maximum Output		Fuse		Wire Size					
		HP	KW	Armature & AC Input	Buss Type	AC Input		Armature Output		Field Power Supply	
						AWG	MM ²	AWG	MM ²	AWG	MM ²
BC20H205-CL	16	5	3.7	50A, 500V	FWH-50A	10	6	10	6	14	2.5
BC20H210-CL	33	10	7.5	80A, 500V	FWH-80A	6	16	6	16	14	2.5
BC20H215-CL	49	15	11.2	100A, 500V	FWH-100A	4	25	3	30	14	2.5
BC20H220-CL	62	20	14.9	150A, 500V	FWH-150A	3	30	2	35	14	2.5
BC20H225-CL	82	25	18.6	150A, 500V	FWH-150A	1	50	1/0	54	14	2.5
BC20H240-CL	115	40	29.8	300A, 500V	FWH-300A	1/0	54	2/0	70	14	2.5
BC20H250-CL	148	50	37.3	350A, 500V	FWH-350A	3/0	95	4/0	120	14	2.5
BC20H260-CL	172	60	44.8	400A, 500V	FWH-400A	4/0	120	300MCM	150	14	2.5
BC20H275-CL	221	75	56	400A, 500V	FWH-400A	4/0	120	300MCM	150	14	2.5
BC20H2125-CL	182	125	93	600A, 500V	FWP-600A	(2)300MCM	150	(2)400MCM	200	14	2.5

Table 2-5 Recommended Wire Size – 460VAC

Catalog Number	Input Amp	Maximum Output		Fuse		Wire Size					
		HP	KW	Armature & AC Input	Buss Type	AC Input		Armature Output		Field Power Supply	
						AWG	MM ²	AWG	MM ²	AWG	MM ²
BC20H410-CL	16	10	7.5	50A, 700V	FWP-50A	10	6	10	6	14	2.5
BC20H420-CL	33	20	14.9	80A, 700V	FWP-80A	6	16	6	16	14	2.5
BC20H430-CL	49	30	22.4	100A, 700V	FWP-100A	4	25	3	30	14	2.5
BC20H440-CL	62	40	29.8	150A, 700V	FWP-150A	3	30	2	35	14	2.5
BC20H450-CL	82	50	37.3	150A, 700V	FWP-150A	1	50	1/0	54	14	2.5
BC20H475-CL	115	75	56	300A, 700V	FWP-300A	1/0	54	2/0	70	14	2.5
BC20H4100-CL	148	100	74.6	350A, 700V	FWP-350A	3/0	95	4/0	120	14	2.5
BC20H4125-CL	175	125	93	400A, 700V	FWP-400A	4/0	120	300MCM	150	14	2.5
BC20H4150-CL	221	150	112	400A, 700V	FWP-400A	300MCM	150	500MCM	240	14	2.5
BC20H4200-CL	287	200	149	600A, 700V	FWP-600A	(2) 300MCM	150	(2) 400MCM	200	14	2.5
BC20H4250-CL	344	250	187	600A, 700V	FWP-600A	(2) 300MCM	150	(2) 400MCM	200	14	2.5
BC20H4300-CL	410	300	224	800A, 700V	FWP-800A	(2) 400MCM	200	(2) 500MCM	240	14	2.5
BC20H4400-CL	549	400	298	(2) 500A, 700V	FWP-500A	(3) 300MCM	150	(3) 500MCM	240	* (2) 18	0.75
BC20H4500-CL	689	500	373	(2) 600A, 700V	FWP-600A	(3) 500MCM	240	(4) 400MCM	200	* (2) 18	0.75
BC20H4600-CL	787	600	448	(2) 600A, 700V	FWP-600A	(4) 500MCM	240	(4) 500MCM	240	* (2) 18	0.75

* Wire size depends on the current required for motor.

Note: All wire sizes based on 75°C copper wire, 40°C ambient temperature, 4-6 conductors per conduit or raceway except as noted.

Note: Wire sizes shown above are for normal length power runs. Voltage drop to the motor and control should be considered. For longer power runs, use heavier gauge copper wire (within the size of the wire terminals).

Table 2-6 Fuses

Armature Input Wire (Copper)	Field Power Output Wire (Copper)
Standard Field Power Supply (15A)	Buss KTK 20
High Capacity Field Power Supply (40A)	Baldor V4360050 (Gould A70Q50)
Reference/Supply Fuses	Buss FNQ 2/10A

Figure 2-1 20H Enclosure Component Locations

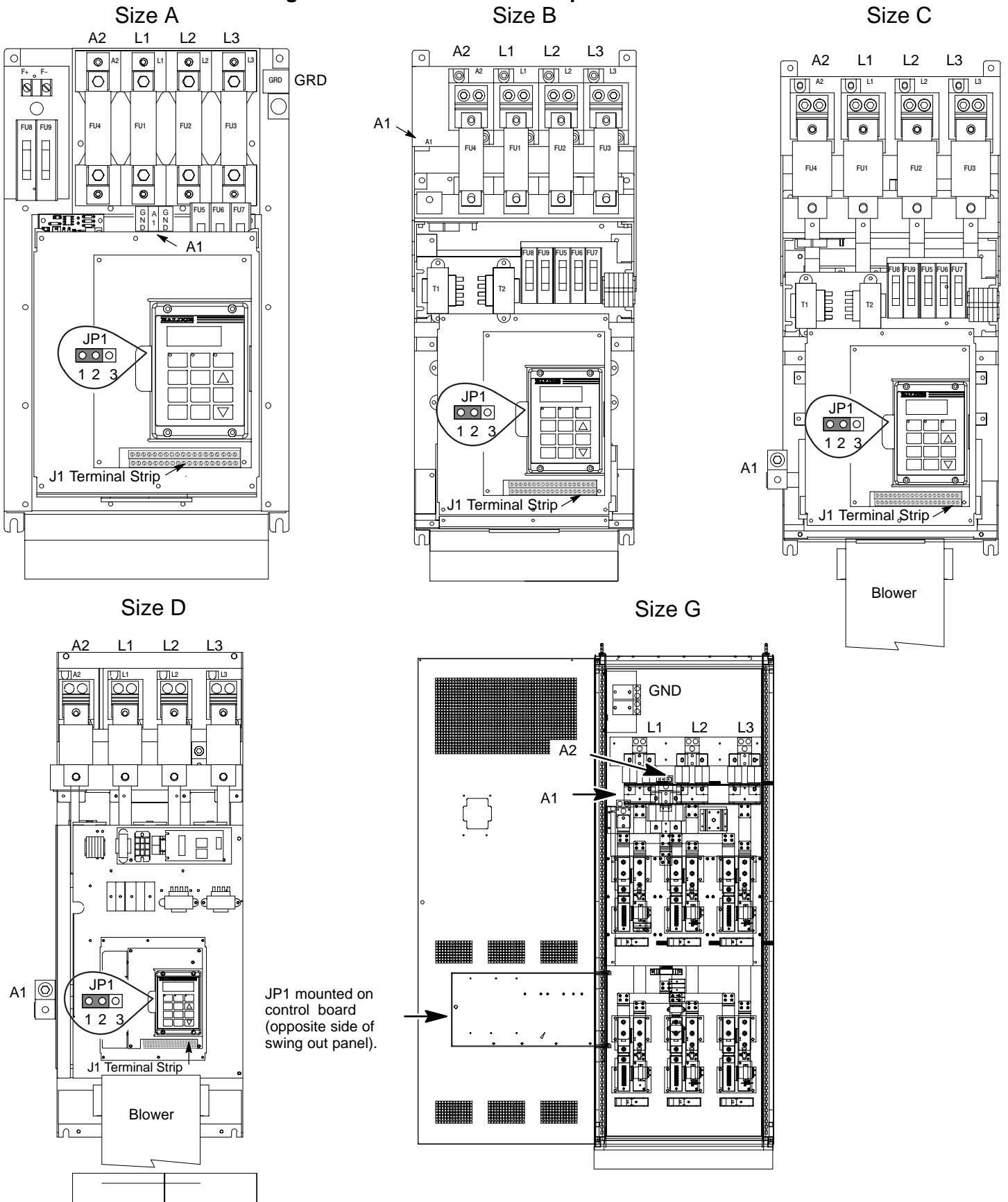

Three Phase Input Power Three phase AC power connections are shown in Figure 2-2.

Figure 2-2 Three Phase AC Power Connections

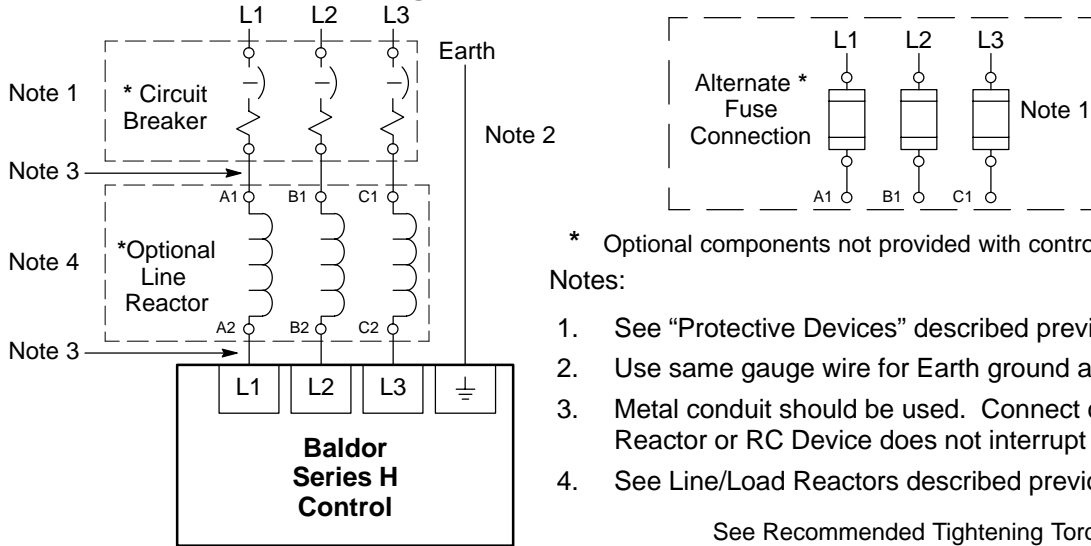

* Optional components not provided with control.
Notes:

1. See "Protective Devices" described previously in this section.
2. Use same gauge wire for Earth ground as is used for L1, L2 and L3.
3. Metal conduit should be used. Connect conduits so the use of a Reactor or RC Device does not interrupt EMI/RFI shielding.
4. See Line/Load Reactors described previously in this section.

See Recommended Tightening Torques in Section 5.

Grounding by using conduit or panel connection is not adequate. A separate conductor of the proper size must be used as a ground conductor.

Cooling Fan Connection Some controls are equipped with cooling fans (pancake fans) or centrifugal blowers which must be connected to single phase power. 230VAC controls have 230VAC single phase rated fans and 460VAC controls have 115VAC rated fans. Refer to the rating plate located near the fan for voltage identification. Connect the proper single phase power to the two fan terminals located on the side of the fan.

D size controls have a centrifugal blower that may be connected to either 230 or 460 volt AC single phase power. Connect the 230VAC or 460VAC to the blower as shown in Figure 2-3. The terminal block is located on the blower.

Figure 2-3 230VAC/460VAC Blower Connections (Single Phase)

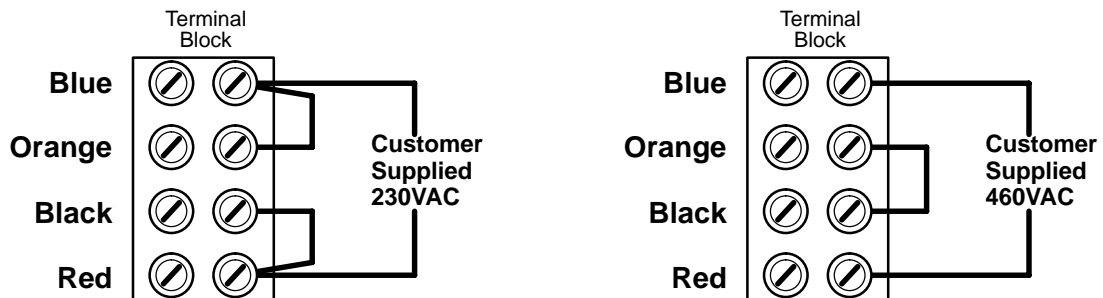

Optional Field Power Module

Connection information is provided in "Interconnection Diagram" in Section 5 of this manual.

Note: L1 and L2 inputs to the optional Field Power module are phase sensitive. Be sure that the L1 input connects to L1 only and that the L2 input connects to L2 only, as shown in the diagram.

Motor Connections

Motor connections are shown in Figure 2-4.

Note: If your motor requires more than 85% of the line voltage as its DC input voltage, a step up transformer is required. This is added between the incoming line terminals and the L1 and L2 terminals of the field supply module. This connection is phase sensitive with main input L1 and L2. The maximum input voltage to the field supply module is 528VAC @ 60Hz.

Figure 2-4 Motor Connections

* Optional components not provided with 20H Control.

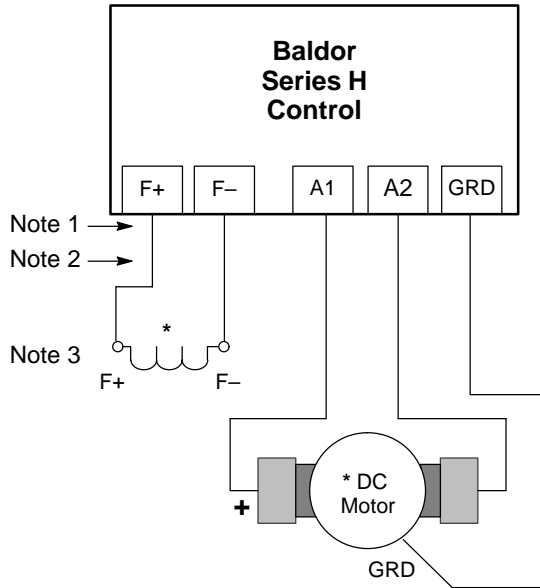

Notes:

1. Shield wires inside a metal conduit.
2. Metal conduit should be used to shield output wires (between control and motor). Connect conduits so the use of Load Reactor or RC Device does not interrupt EMI/RFI shielding.
3. Connect the field power supply leads of the DC motor to control terminals F+ and F-. The standard field supply provides up to 85% of the line voltage as its DC output voltage @ 15 amperes. A high capacity field power supply provides up to 85% of the line voltage as its DC output voltage @ 40 amperes (see Optional Field Power Module described previously).

Typical shunt wound motor field connection 120/240V or 150/300V. Consult manufacturers specific motor data for details.

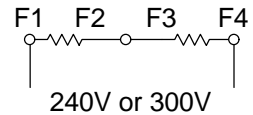
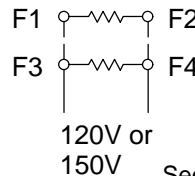

See Recommended Tightening Torques in Section 5.

Note: The 20H control may be connected to a permanent magnet field DC motor. In this case, the field supply is not connected, the Level 2 Motor Data block, Motor Field parameter is set to PERM MAGNET, and the Level 1 Field Control block, Field PWR Supply parameter is set to NONE.

M-Contactor

If required by local codes or for safety reasons, an M-Contactor (motor circuit contactor) may be installed. However, incorrect installation or failure of the M-contactor or wiring may damage the control. If an M-Contactor is installed, the control must be disabled for at least 20msec before the M-Contactor is opened or the control may be damaged. M-Contactor connections are shown in Figure 2-5.

Figure 2-5 Optional M-Contactor Connections

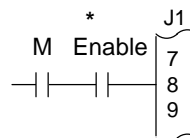
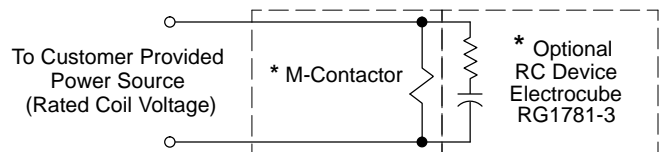
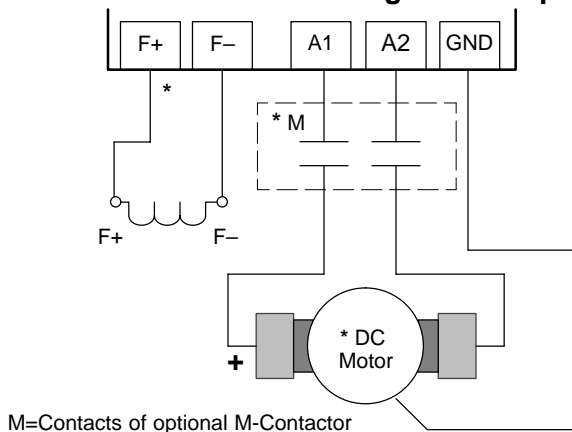

Note: Close "Enable" after "M" contact closure.

See Recommended Tightening Torques in Section 5.

M-Contactor Continued

Control faults may occur if the control is enabled before the M Contactor is closed. The timing diagram shown in Figure 2-6 defines the correct operating sequence.

At Turn ON

Allow 20 milli seconds for the coil of the M contactor to energize and close the contactor before the Enable input at J1-8 is issued.

At Turn OFF

Do not allow the M Contactor to open until motor shaft rotation has stopped and the Enable at J1-8 has been removed. If this sequence does not occur, a TACH LOSS fault may be issued by the control.

Note: This example shows a "Drive ON" output to a PLC that is used to command the 20H control and the holding brake.

Figure 2-6 M Contactor Operation Sequence

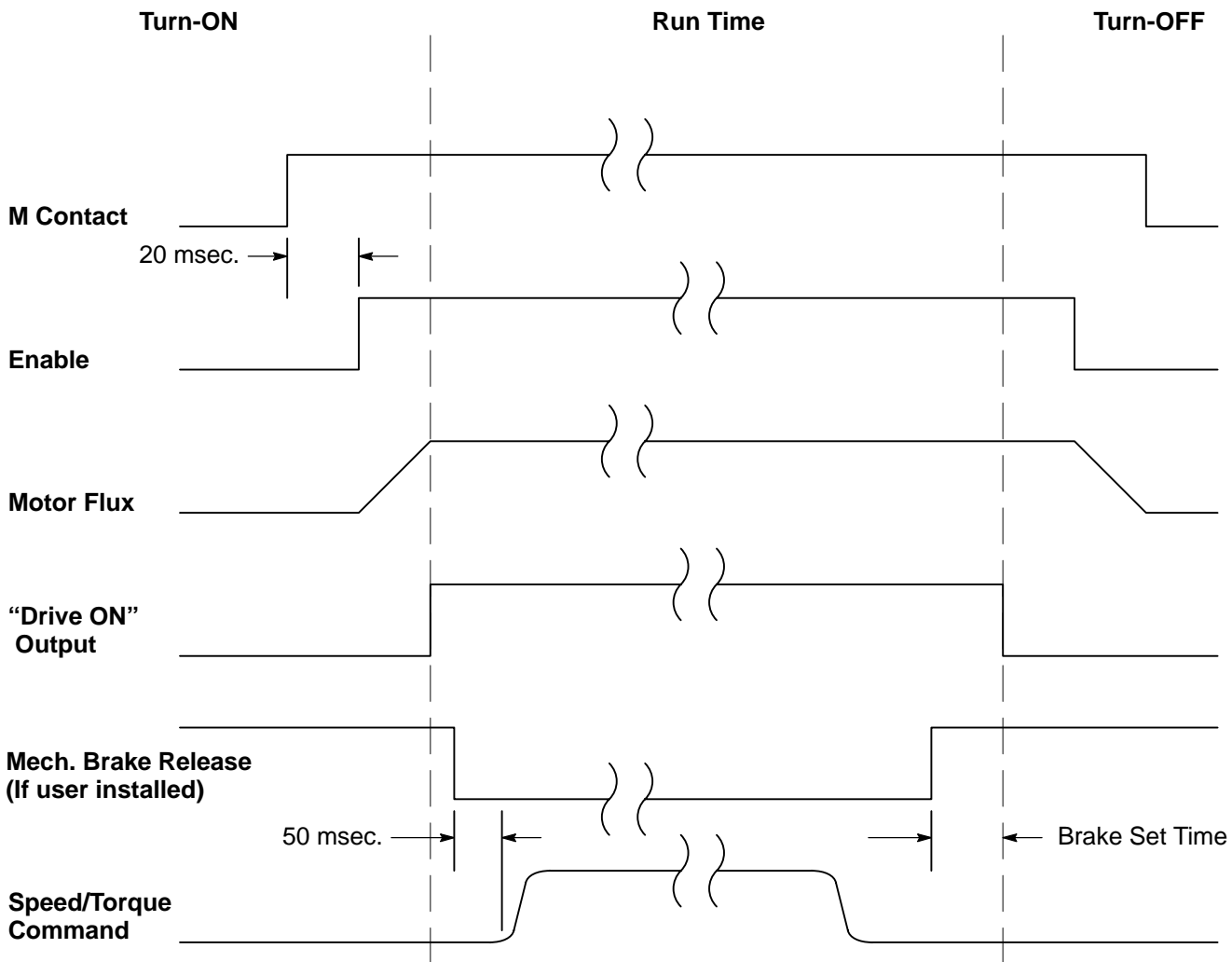

External Trip Input

Terminal J1-16 is available for connection to a normally closed customer supplied relay in all operating modes as shown in Figure 2-7. The thermostat contact should be a dry contact type with no power available from the contact. If the motor thermostat activates, the control will automatically disable and give an External Trip fault. When the motor cools sufficiently and the motor thermostat resets itself, the control may be restarted.

Connect the External Trip Input wires to J1-16 and J1-17. Do not place these wires in the same conduit as the motor power leads.

To activate the External Trip input, the Level 2 Protection block, External Trip parameter must be set to "ON".

Figure 2-7 Motor Temperature Relay

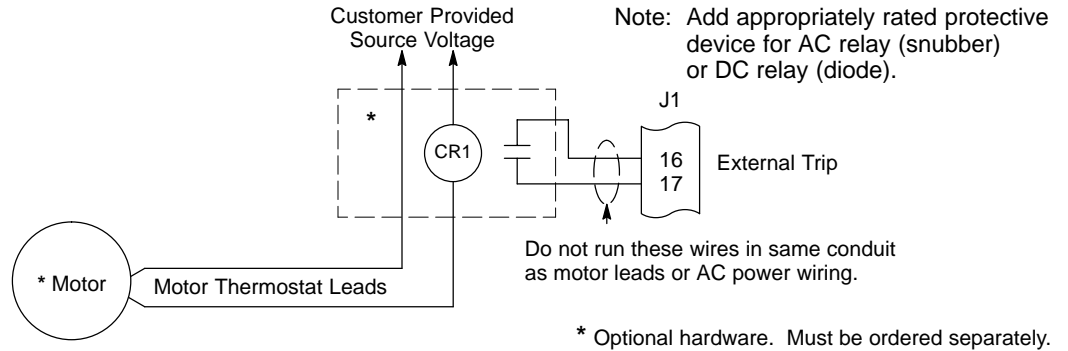

See recommended terminal tightening torques in Section 5.

Encoder Installation

Electrical isolation of the encoder shaft and housing from the motor is required. Electrical isolation prevents capacitive coupling of motor noise that will corrupt the encoder signals. Baldor provides shielded wire for encoder connection. Figure 2-8 shows the electrical connections between the encoder and the encoder connector.

Figure 2-8 Differential Encoder Connections

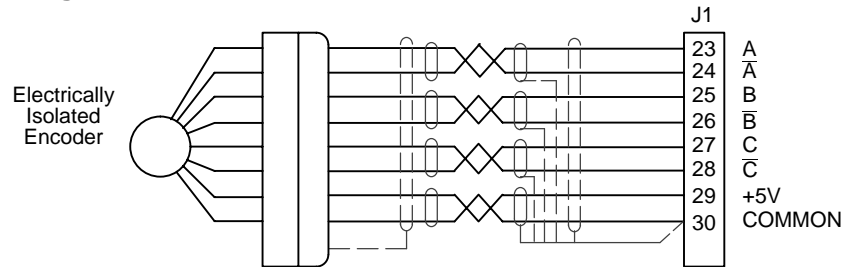

Single Ended Connections

Differential inputs are recommended for best noise immunity. If only single ended encoder signals are available, connect them to A, B, and INDEX (C) (J1-23, J1-25 and J1-27 respectively). A, B, and INDEX (C) are then connected to common at J1-30 as shown in Figure 2-9.

Figure 2-9 Single Ended Encoder Connections

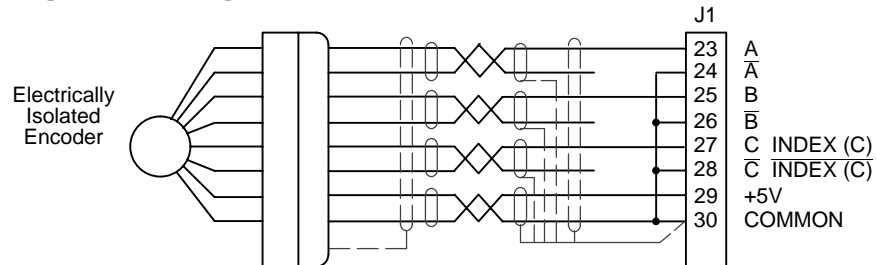

Home (Orient) Switch Input The Home or Orient function causes the motor shaft to rotate to a predefined home position. The home position is located when a machine mounted switch or the encoder “Index” pulse is activated (closed). Home is defined by a rising signal edge at terminal J1-27. The shaft will continue to rotate only in a CW direction for a user defined offset value. The offset is programmed in the Level 2 Miscellaneous Homing Offset parameter. The speed at which the motor will “Home” or orient is set with the Level 2 Miscellaneous Homing Speed parameter.

A machine mounted switch may be used to define the Home position in place of the encoder index channel. A differential line driver output from a solid state switch is preferred for best noise immunity. Connect this differential output to terminals J1-27 and J1-28.

A single ended solid-state switch or limit switch should be wired as shown in Figure 2-10. Regardless of the type of switch used, clean rising and falling edges at J1-27 are required for accurate positioning.

Figure 2-10 Typical Home or Orient Switch Connections

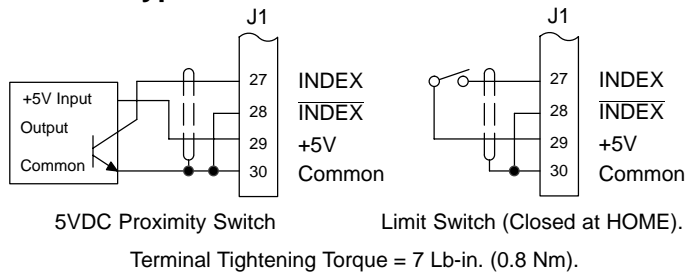

Buffered Encoder Output The control provides a buffered encoder output on pins J1-31 to J1-38 as shown in Figure 2-11. This output may be used by external hardware to monitor the encoder signals. It is recommended that this output only drive one output circuit load.

Figure 2-11 Buffered Encoder Output

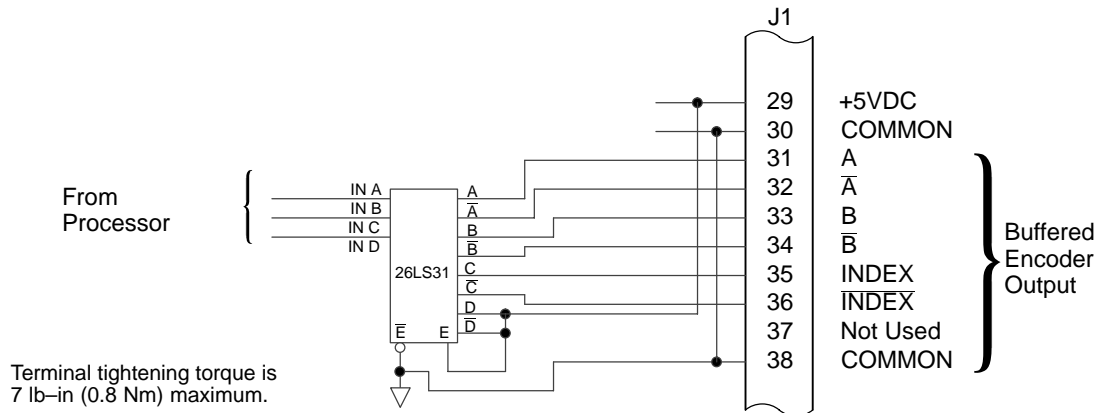

Control Circuit Connections Eight operating modes are available. These modes define the basic motor control setup and the operation of the J1 input and output terminals. After the circuit connections are completed, the operating mode is selected by programming the Operating Mode parameter in the Level 1 Input programming Block. Available operating modes include:

- Keypad Control
- Standard Run, 3 Wire Control
- 15 Speed, 2 Wire Control
- Bipolar Speed or Torque
- Process Control
- Serial
- Bipolar Hoist
- 7 Speed Hoist

Each mode requires connections to the J1 terminal strip (except the keypad mode, all connections are optional). The J1 terminal strip is shown in Figure 2-12. The connection of each input or output signal is described in the following pages.

Figure 2-12 Control Signal Connections

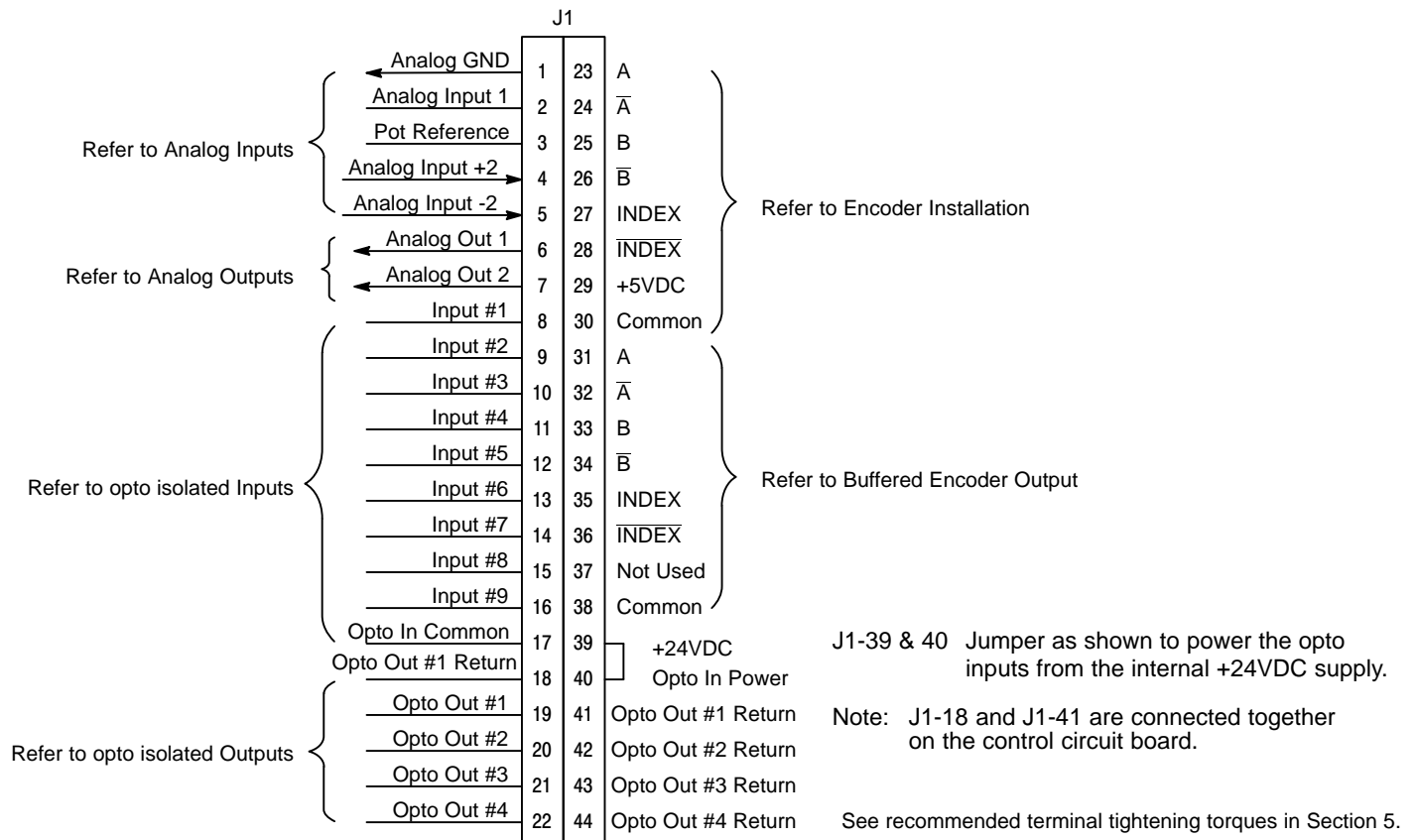

Analog Inputs

Two analog inputs are available: analog input #1 (J1-1 and J1-2) and analog input #2 (J1-4 and J1-5) as shown in Figure 2-13. Either analog input may be selected in the Level 1 INPUT block, Command Select parameter value. Analog input #1 is selected if the parameter value is "Potentiometer". Analog input #2 is selected if the parameter value is "+/-10Volts, +/-5 Volts or 4-20mA". Figure 2-14 shows the equivalent circuits of the Analog Inputs.

Figure 2-13 Analog Inputs and Outputs

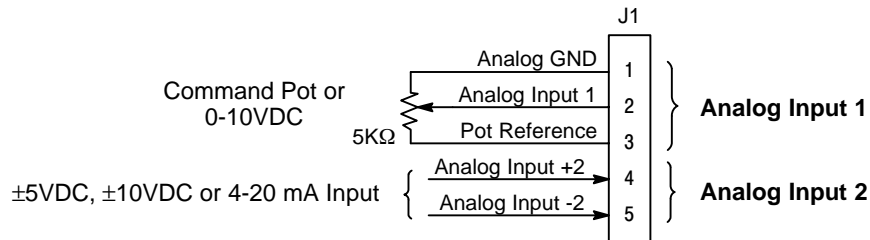

See recommended terminal tightening torques in Section 5.

Analog Input #1 (Single Ended)

When using a potentiometer as the speed command, process feedback or setpoint source, the Level 1 Input block COMMAND SELECT parameter must be set to "POTENTIOMETER".

Note: A potentiometer value of 5kΩ to 10kΩ, 0.5 watt may be used.

Parameter Selection

The single ended analog input #1 can be used in one of three ways:

1. Speed or Torque command (Level 1 Input block, Command Select=Potentiometer).
2. Process Feedback (Level 2 Process Control block, Process Feedback=Potentiometer).
3. Setpoint Source (Level 2 Process Control block, Setpoint Source=Potentiometer).

When using Analog Input #1, the respective parameter must be set to "POTENTIOMETER".

Analog Input #2 (Differential)

Analog input #2 accepts a differential command ±5VDC, ±10VDC or 4-20 mA.

If pin J1-4 is positive with respect to pin 5, the motor will rotate in the forward direction.

If pin J1-4 is negative with respect to pin 5, the motor will rotate in the reverse direction.

JP1 must be set for voltage or current operation as required. Analog Input #2 can be connected for single ended operation by grounding either of the inputs, provided the common mode voltage range is not exceeded.

Note: The common mode voltage can be measured with a voltmeter. Apply the maximum command voltage to analog input 2 (J1-4, 5). Measure the AC and DC voltage across J1-1 to J1-4. Add the AC and DC readings together. Measure the AC and DC voltage from J1-1 to J1-5. Add the AC and DC readings together.

If either of these measurement totals exceeds ±15 volts, then the common mode voltage range has been exceeded. To correct this condition, either change the command source or isolate the command signal with a signal isolator.

Figure 2-14 Analog Inputs Equivalent Circuits

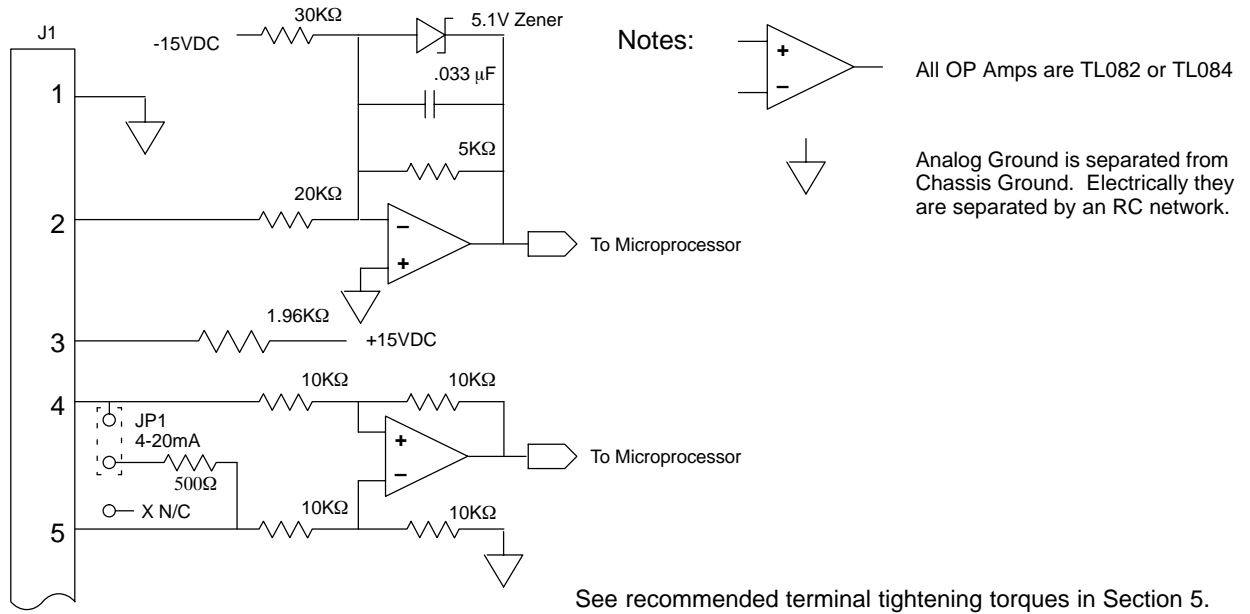

Analog Outputs

Two programmable analog outputs are provided on J1-6 and J1-7. See Figure 2-15. These outputs are scaled 0 - 5 VDC (1mA maximum output current) and can be used to provide real-time status of various control conditions. The output conditions are defined in Section 4 of this manual.

The return for these outputs is J1-1 analog ground. Each output is programmed in the Level 1 Output block.

Figure 2-15 Analog Outputs Equivalent Circuits

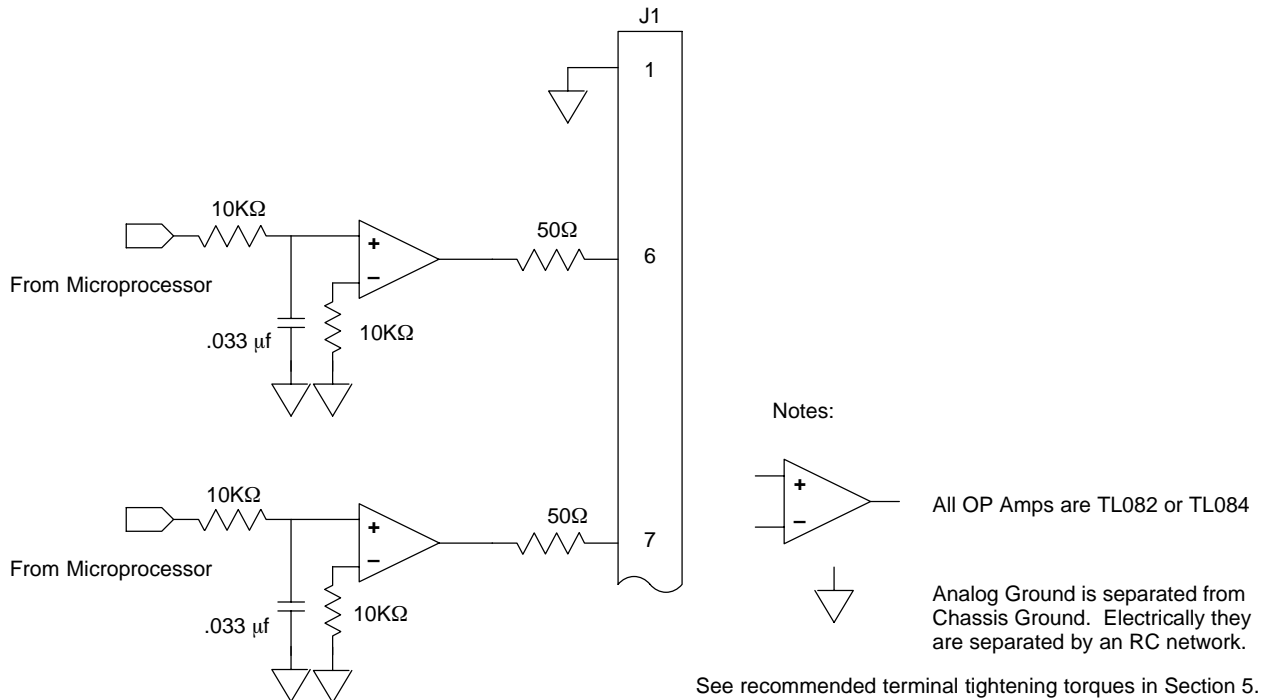

Serial Operating Mode The Serial operating mode requires one of the optional Serial Interface expansion boards (RS232, RS422 or RS485). Installation and operation information for these serial expansion boards is provided in Serial Communications expansion board manual MN1310. This manual is shipped with the serial expansion boards.

Keypad Operating Mode The Keypad operating mode allows the control to be operated from the keypad. This mode requires no connections to J1. However, the External Trip input may optionally be used. All other opto inputs remain inactive. The analog outputs and opto-outputs remain active at all times.

Parameter Selection

For operation in Keypad mode, set the Level 1 Input block, Operating Mode parameter to Keypad. The STOP key can operate in two ways:

- Press STOP key one time to brake or coast to stop.
- Press STOP key two times to disable control.

The External Trip input causes a fault condition during a motor over temperature condition (when normally closed input opens). The External Trip input (J1-16) must be connected and the External Trip parameter in the Level 2 Protection block must be set to "ON". When J1-16 is opened, an external trip fault occurs. The control will disable and the motor coasts to a stop. An external trip fault is displayed on the keypad display (also logged into the fault log).

Figure 2-16 Keypad Control Connection Diagram

J1-16 If J1-16 is connected, you must set Level 2 Protection block, External Trip to "ON" to activate the opto input. CLOSED allows normal operation. OPEN causes an external trip fault. The control will disable and the motor coasts to a stop. An external trip fault is displayed (also logged in the fault log).

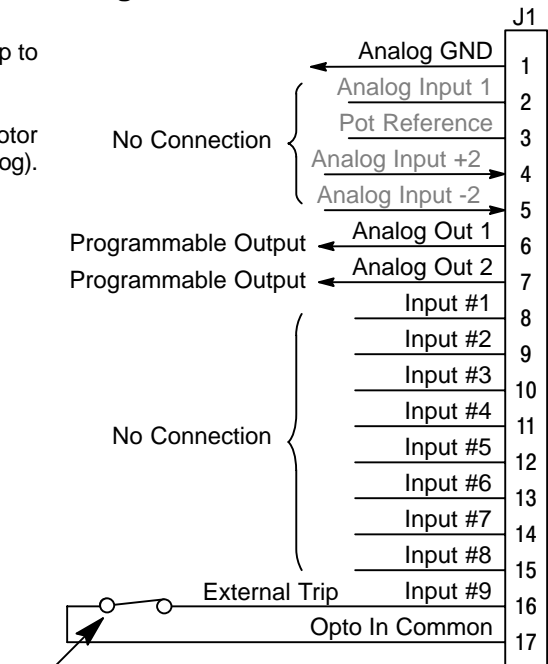

Refer to Figure 2-7.

See recommended terminal tightening torques in Section 5.

Standard Run 3 Wire Mode Connections

In Standard Run mode, the control is operated by the opto Isolated inputs at J1-8 through J1-16 and the analog command input. The opto inputs can be switches as shown in Figure 2-17 or logic signals from another device. The External Trip opto input at J1-16 is active if connected as shown and the Level 2 Protection block, External Trip parameter is set to ON.

Figure 2-17 Standard Run 3-Wire Connection Diagram

J1-8	CLOSED allows normal operation. OPEN disables the control and motor coasts to a stop.
J1-9	MOMENTARY CLOSED starts motor operation in the Forward direction. In JOG mode (J1-12 CLOSED), continuous CLOSED jogs motor in the Forward direction.
J1-10	MOMENTARY CLOSED starts motor operation in the Reverse direction. In JOG mode (J1-12 CLOSED), CONTINUOUS closed JOGS motor in the Reverse direction.
J1-11	MOMENTARY OPEN motor decels to stop (depending on Keypad Stop mode).
J1-12	CLOSED places control in JOG mode, Forward and Reverse run are used to jog the motor.
J1-13	CLOSED selects ACC / DEC / S-CURVE group 2. OPEN selects ACC / DEC / S-CURVE group 1.
J1-14	CLOSED selects preset speed #1, (J1-12, will override this preset speed). OPEN allows speed command from Analog input #1 or #2.
J1-15	CLOSED to reset fault condition. OPEN to run.
J1-16	If J1-16 is connected, you must set Level 2 Protection block, External Trip to "ON" to activate the opto input. CLOSED allows normal operation. OPEN causes an external trip fault. The control will disable and the motor coasts to a stop. An external trip fault is displayed (also logged in the fault log).

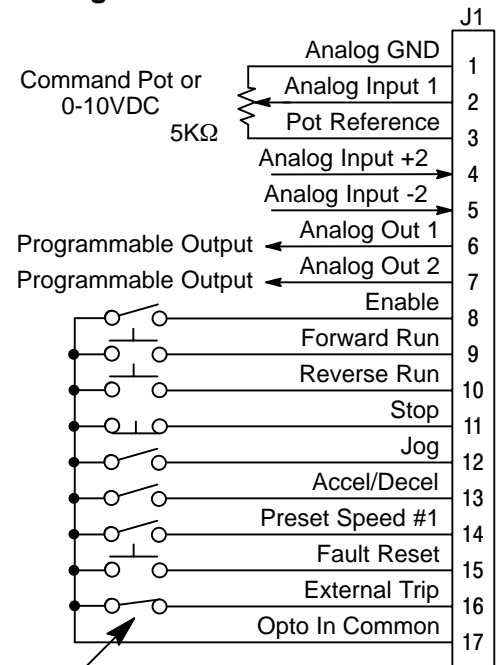

See recommended terminal tightening torques in Section 5.

15 Speed 2-Wire Operating Mode

Operation in the 15 Speed 2-Wire mode is controlled by the opto isolated inputs at J1-8 through J1-16. The opto inputs can be switches as shown in Figure 2-18 or logic signals from another device.

Switched inputs at J1-11 through J1-14 allow selection of 15 preset speeds and provide Fault Reset as defined in Table 2-7.

Figure 2-18 15 Speed 2-Wire Control Connection Diagram

- J1-8 CLOSED allows normal operation.
OPEN disables the control and motor coasts to a stop.
- J1-9 CLOSED operates the motor in the Forward direction (with J1-10 open).
OPEN motor decels to stop (depending on Keypad Stop mode).
- J1-10 CLOSED operates motor in the Reverse direction (with J1-9 open).
OPEN motor decels to stop (depending on Keypad Stop mode).
- J1-11-14 Selects programmed preset speeds as defined in Table 2-7.
- J1-15 CLOSED selects ACC / DEC / S-CURVE group 2.
OPEN selects ACC / DEC / S-CURVE group 1.
- Both CLOSED= Forward
Both OPEN = Stop
- * All CLOSED= Fault Reset
- J1-16 If J1-16 is connected, you must set Level 2 Protection block, External Trip to "ON" to activate the opto input.
CLOSED allows normal operation.
OPEN causes an external trip fault. The control will disable and the motor coasts to a stop. An external trip fault is displayed (also logged in the fault log).

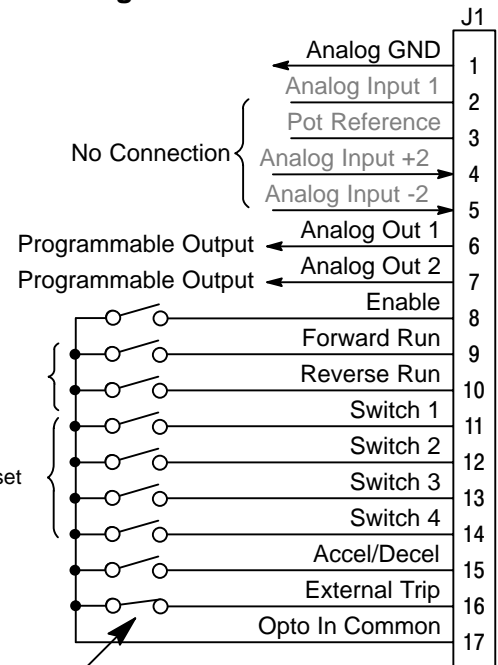

* Refer to truth table, Table 2-7.

See recommended terminal tightening torques in Section 5.

Table 2-7 Switch Truth Table for 15 Speed, 2 Wire Control Mode

Function	J1-11	J1-12	J1-13	J1-14
Preset 1	Open	Open	Open	Open
Preset 2	Closed	Open	Open	Open
Preset 3	Open	Closed	Open	Open
Preset 4	Closed	Closed	Open	Open
Preset 5	Open	Open	Closed	Open
Preset 6	Closed	Open	Closed	Open
Preset 7	Open	Closed	Closed	Open
Preset 8	Closed	Closed	Closed	Open
Preset 9	Open	Open	Open	Closed
Preset 10	Closed	Open	Open	Closed
Preset 11	Open	Closed	Open	Closed
Preset 12	Closed	Closed	Open	Closed
Preset 13	Open	Open	Closed	Closed
Preset 14	Closed	Open	Closed	Closed
Preset 15	Open	Closed	Closed	Closed
Fault Reset	Closed	Closed	Closed	Closed

Bipolar Speed or Torque Operating Mode

Provides bipolar speed or torque control. Also, you may store up to two complete sets of operating parameters. This is important if you wish to store and use different acceleration rates, speed commands, jog speeds or to store tuning parameter values for different motors etc. The opto inputs can be switches as shown in Figure 2-19 or logic signals from another device.

Figure 2-19 Bipolar Speed or Torque Connection Diagram

- J1-8 CLOSED allows normal operation.
OPEN disables the control & motor coasts to a stop.
- J1-9 CLOSED to enable operation in the Forward direction.
OPEN TO DISABLE Forward operation (drive will brake to a stop if a Forward command is still present).
Reverse operation is still possible if J1-10 is closed.
- J1-10 CLOSED to enable operation in the Reverse direction.
OPEN to disable Reverse operation (drive will brake to a stop if a Reverse command is still present).
Forward operation is still possible if J1-9 is closed.
- Note: If J1-9 and J1-10 are both opened, the drive will brake to a stop.
- J1-11 CLOSED causes the motor to rotate in the forward direction until the load reaches a marker or external switch location.
OPEN allows normal operation.
- J1-12 CLOSED puts the control in torque (current) command mode.
OPEN puts the control in speed (velocity) command mode.
- J1-13 Select from the parameter tables defined in Table 2-8.
- J1-15 Momentary CLOSED to reset fault condition.
OPEN allows normal operation.
- J1-16 If J1-16 is connected, you must set Level 2 Protection block, External Trip to "ON" to activate the opto input.
CLOSED allows normal operation.
OPEN causes an external trip fault. The control will disable and the motor coasts to a stop. An external trip fault is displayed (also logged in the fault log).

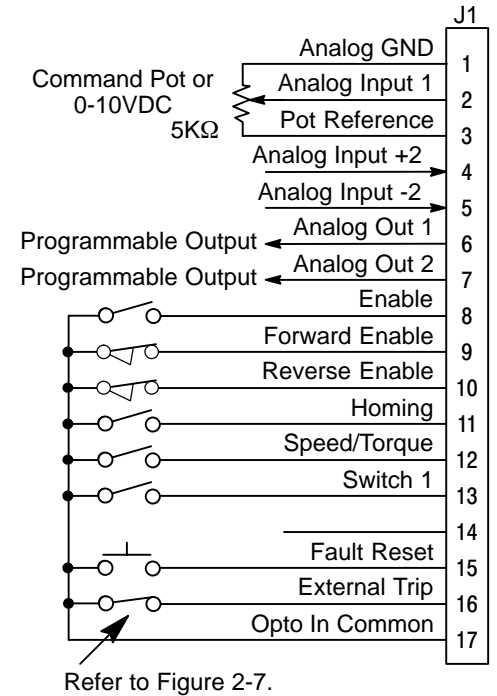

See recommended terminal tightening torques in Section 5.

Continued on next page

Multiple Parameter Sets The following procedure allows you to program up to two complete sets of parameter values and to use these multiple parameter sets. When programming each parameter set, use the ENTER key to accept and automatically save parameter values.

Note: Preset speed does not apply to table select.

Note: Except for the Level 1 Operating Mode parameter, the control can be programmed in the REMOTE mode with the drive enabled and switches in step 4 closed. The control must be disabled to change the operating mode parameter.

1. Set the Level 1 INPUT block, Operating Mode parameter value to BIPOLAR in each of the parameter sets.
2. Open switch J1-13. Be sure switches J1-9 and J1-10 are OPEN, J1-8 is CLOSED. Enter all parameter values, and autotune as instructed in Section 3 of this manual. This creates and saves the first parameter set which is numbered Table#0.
3. Close switch J1-13. Be sure switches J1-9 and J1-10 are OPEN, J1-8 is CLOSED. Enter all parameter values, and autotune as instructed in Section 3 of this manual. This creates and saves the second parameter set which is numbered Table#1.
4. Program the parameter values for each table. Remember that to change the value of a parameter in one of the parameter tables, you must first select the table using switch J1-13. You cannot change a value in a table until you have first selected that table.

Note: Table#0 must contain the greater of the two MAX SPEED parameters. The control always starts in Table#0.

Table 2-8 Bipolar Mode Table Select Truth Table

Function	J1-13
Parameter Table #0	Open
Parameter Table #1	Closed

Note: All parameters except operating mode can be changed and saved for each table.

Note: Preset speed does not apply to table select.

Process Operating Mode

Figure 2-20 Process Mode Connection Diagram

- J1-8 CLOSED allows normal operation.
OPEN disables the control & motor coasts to a stop.
- J1-9 CLOSED to enable operation in the Forward direction.
OPEN TO DISABLE Forward operation (drive will brake to a stop if a Forward command is still present). Reverse operation is still possible if J1-10 is closed.
- J1-10 CLOSED to enable operation in the Reverse direction.
OPEN to disable Reverse operation (drive will brake to a stop if a Reverse command is still present). Forward operation is still possible if J1-9 is closed.
- Note: If J1-9 and J1-10 are both opened, the drive will brake to a stop.
- J1-11 CLOSED = TABLE 1, OPEN = TABLE 0. (See multiple parameter sets.)
- J1-12 CLOSED, the control is in torque (current) command mode.
OPEN, the control is in speed (velocity) command mode.
- J1-13 CLOSED to enable the Process Mode.
- J1-14 CLOSED places control in JOG mode. The control will only JOG in the forward direction.
- J1-15 CLOSED to reset a fault condition.
OPEN to run.
- J1-16 If J1-16 is connected, you must set Level 2 Protection block, External Trip to "ON" to activate the opto input.
CLOSED allows normal operation.
OPEN causes an external trip fault. The control will disable and the motor coasts to a stop. An external trip fault is displayed (also logged in the fault log).

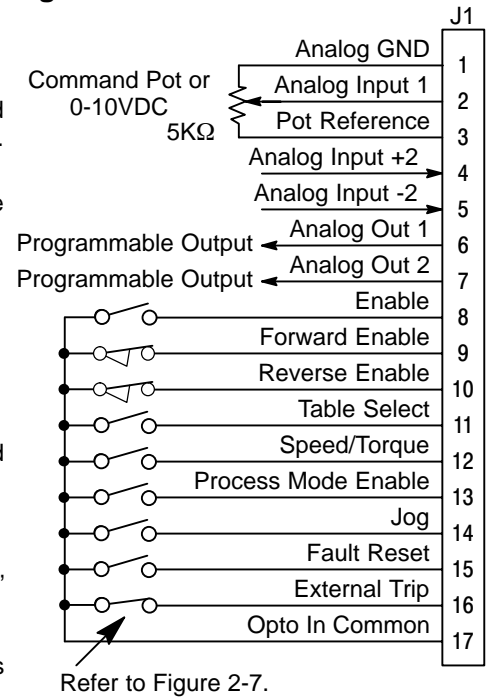

See recommended terminal tightening torques in Section 5.

Table 2-9 Process Mode Input Signal Compatibility

Setpoint or Feedforward	Feedback						
	J1-1 & 2	J1-4 & 5	5V EXB ¹	10V EXB ¹	4-20mA EXB ¹	3-15 PSI EXB ²	DC Tach EXB ³
J1-1 & 2	■						
J1-4 & 5		■					
5V EXB ¹			■				
10V EXB ¹			■	■			
4-20mA EXB ¹			■	■	■		
3-15 PSI EXB ²			■	■	■	■	
DC Tach EXB ³							■
EXB PULSE FOL ⁴ ⁵							■
Serial ⁵ ⁶			■	■	■	■	■

- ¹ Requires expansion board EXB007A01 (High Resolution Analog I/O EXB).
- ² Requires expansion board EXB004A01 (4 Output Relays/3-15 PSI Pneumatic Interface EXB).
- ³ Requires expansion board EXB006A01 (DC Tachometer Interface EXB).
- ⁴ Requires expansion board EXB005A01 (Master Pulse Reference/Isolated Pulse Follower EXB).
- ⁵ Used for Feedforward only. Must not be used for Setpoint Source or Feedback.
- ⁶ Requires expansion board EXB001A01 (RS232 Serial Communication EXB). or Requires expansion board EXB002A01 (RS422/RS485 High Speed Serial Communication EXB).
- Conflicting inputs. Do not use same input signal multiple times.
- ▣ Conflicting level 1 or 2 expansion boards. Do not use!

Bipolar Hoist Mode Connections

This mode of operation allows the user to store two (2) complete sets of operating parameters for hoist operation. Table 2-10 shows switch settings required to access each parameter table. When programming each parameter set, use the ENTER key to accept and automatically save parameter values.

Note: Except for the Level 1 Operating Mode parameter, the control can be programmed in the REMOTE mode with the drive enabled and switches in step 4 closed. The control must be disabled to change the operating mode parameter.

1. Set the Level 1 INPUT block, Operating Mode parameter value to BIPOLAR in each of the parameter sets.
2. Open switch J1-13. Be sure switches J1-9 and J1-10 are OPEN, J1-8 is CLOSED. Enter all parameter values, and autotune as instructed in Section 3 of this manual. This creates and saves the first parameter set which is numbered Table#0.
3. Close switch J1-13. Be sure switches J1-9 and J1-10 are OPEN, J1-8 is CLOSED. Enter all parameter values, and autotune as instructed in Section 3 of this manual. This creates and saves the second parameter set which is numbered Table#1.
4. Remember that to change the value of a parameter in one of the parameter tables, you must first select the table using switch J1-13. You cannot change a value in a table until you have first selected that table.

Note: Table#0 must contain the greater of the two MAX SPEED parameters. The control always starts in Table#0.

Table 2-10 Bipolar Mode Table Select Truth Table

Function	J1-13
Parameter Table #0	Open
Parameter Table #1	Closed

Note: All parameters except operating mode can be changed and saved for each table.

Note: Preset speed does not apply to table select.

Figure 2-21 Bipolar Hoist Connection Diagram

- J1-8 CLOSED allows normal operation.
OPEN disables the control & motor coasts to a stop.
 - J1-9 CLOSED to enable operation in the Forward direction.
OPEN TO DISABLE Forward operation (drive will brake to a stop if a Forward command is still present).
Reverse operation is still possible if J1-10 is closed.
 - J1-10 CLOSED to enable operation in the Reverse direction.
OPEN to disable Reverse operation (drive will brake to a stop if a Reverse command is still present).
Forward operation is still possible if J1-9 is closed.
- Note: If J1-9 and J1-10 are both opened, the drive will brake to a stop.
- J1-11 CLOSED causes the motor to rotate in the forward direction until the load reaches a marker or external switch location.
OPEN allows normal operation.
 - J1-12 CLOSED puts the control in torque (current) command mode.
OPEN puts the control in speed (velocity) command mode.
 - J1-13 Select from the parameter tables defined in Table 2-11.
 - J1-15 Momentary CLOSED to reset fault condition.
OPEN allows normal operation.
 - J1-16 If J1-16 is connected, you must set Level 2 Protection block, External Trip to "ON" to activate the opto input.
CLOSED allows normal operation.
OPEN causes an external trip fault. The control will disable and the motor coasts to a stop. An external trip fault is displayed (also logged in the fault log).

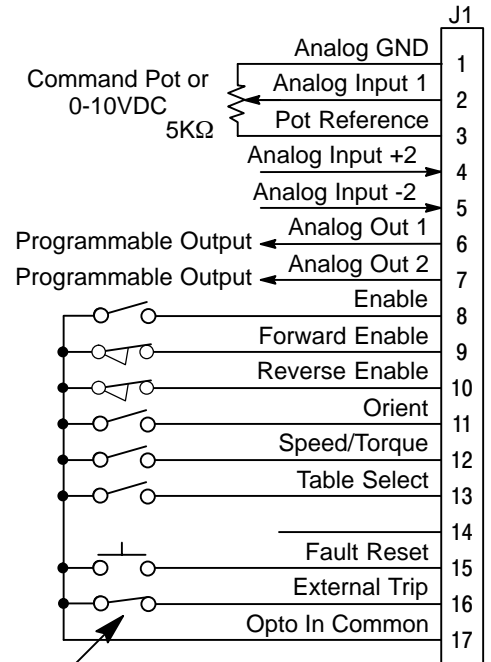

Refer to Figure 2-7.

See recommended terminal tightening torques in Section 5.

Table 2-11 Bipolar Mode Table Select Truth Table

Function	J1-13
Parameter Table #0	Open
Parameter Table #1	Closed

7 Speed Hoist, 2-Wire Mode Connections

Switch Truth Table is defined in Table 2-12.

Operation in the 15 Speed 2-Wire mode is controlled by the Opto Isolated inputs at J1-8 through J1-16. The Opto inputs can be switches as shown in Figure 2-22 or logic signals from another device. The External Trip Opto Input at J1-16 is active if connected as shown and the Level 2 Protection block, External Trip parameter is set to ON.

Switched inputs at J1-11 through J1-13 allow selection of 7 preset speeds for Hoist operation and provide Fault Reset as defined in Table 2-12.

Table 2-12 Switch Truth Table for 15 Speed, 2 Wire Control Mode

Function	J1-11	J1-12	J1-13
Preset 1	Open	Open	Open
Preset 2	Closed	Open	Open
Preset 3	Open	Closed	Open
Preset 4	Closed	Closed	Open
Preset 5	Open	Open	Closed
Preset 6	Closed	Open	Closed
Preset 7	Open	Closed	Closed
Fault Reset	Closed	Closed	Closed

Figure 2-22 7 Speed Hoist, 2-Wire Mode Connection Diagram

- J1-8 CLOSED allows normal operation.
OPEN disables the control and motor coasts to a stop.
- J1-9 CLOSED starts motor operation in the Forward direction.
OPEN motor decels to stop (depending on Keypad Stop mode).
- J1-10 CLOSED starts motor operation in the Reverse direction.
OPEN motor decels to stop (depending on Keypad Stop mode).
- Note: Closing both J1-9 and J1-10 at the same time will reset a fault condition.
- J1-11 Selects preset speeds as defined in the Speed Select Table (Table 2-12).
- J1-12 Selects preset speeds as defined in the Speed Select Table (Table 2-12).
- J1-13 Selects preset speeds as defined in the Speed Select Table (Table 2-12).
- J1-14 CLOSED allows the field to be energized prior to armature enable.
This provides torque instantly when armature is enabled.
- J1-15 CLOSED selects ACC / DEC / S-CURVE group 2.
OPEN selects ACC / DEC / S-CURVE group 1.
- J1-16 If J1-16 is connected, you must set Level 2 Protection block, External Trip to "ON" to activate the opto input.
CLOSED allows normal operation.
OPEN causes an external trip fault. The control will disable and the motor coasts to a stop. An external trip fault is displayed (also logged in the fault log).

* See Table 2-12.

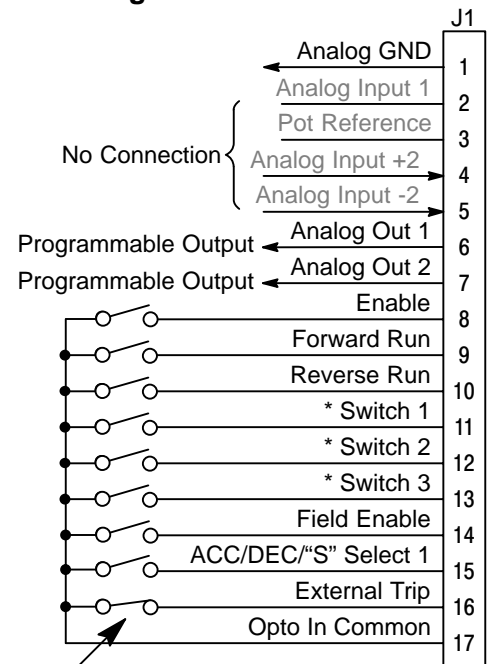

Refer to Figure 2-7.

See recommended terminal tightening torques in Section 5.

Opto-Isolated Inputs

The equivalent circuit of the nine opto inputs is shown in Figure 2-23. The function of each input depends on the operating mode selected and are described previously in this section. This Figure also shows the connections using the internal opto input Supply.

Figure 2-23 Opto-Input Connections (Using Internal Supply)

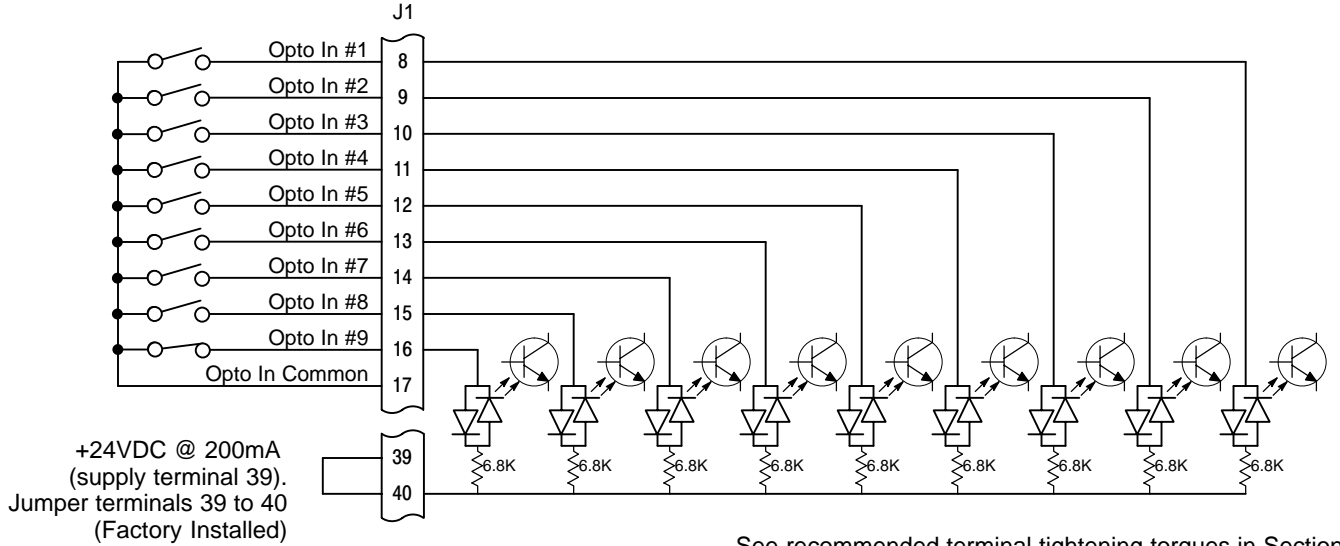

See recommended terminal tightening torques in Section 5.

Figure 2-24 Opto-Input Connections (Using External Supply)

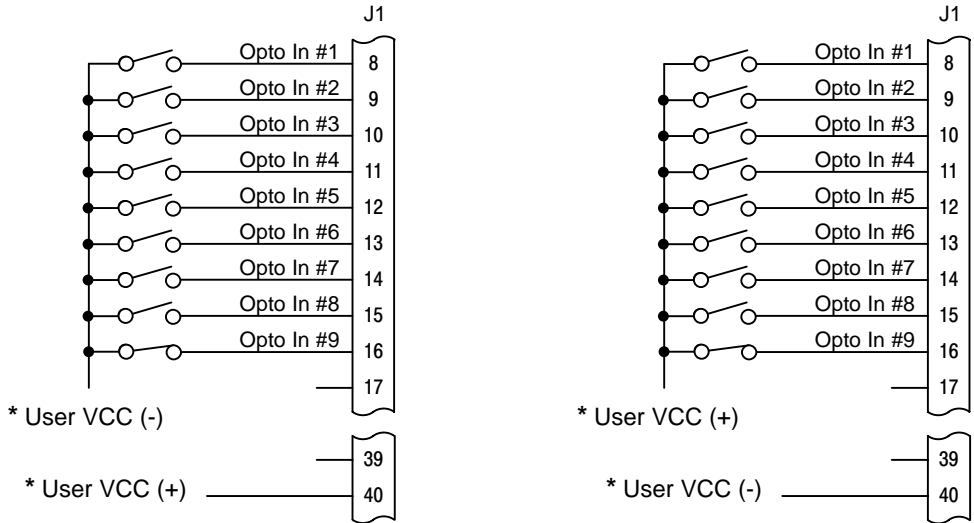

Opto Inputs Closing to Ground

Opto Inputs Closing to +VCC

* User VCC = 10 - 30VDC External Power Source

See recommended terminal tightening torques in Section 5.

Opto-Isolated Outputs

Four programmable Opto-isolated outputs are available at terminals J1-19 through J1-22. See Figure 2-25. Each output may be programmed to represent one output condition. The output conditions are defined in Table 3-2 of Section 3 of this manual.

The Opto-isolated outputs may be configured for sinking or sourcing 60 mA each. However, all must be configured the same. The maximum voltage from opto output to common when active is 1.0 VDC (TTL compatible). The Opto-isolated outputs may be connected in different ways as shown in Figure 2-25. The equivalent circuit for the Opto-isolated outputs is shown in Figure 2-26.

If the opto outputs are used to directly drive a relay, a flyback diode rated at 1A, 100 V (IN4002) minimum should be connected across the relay coil. See Electrical Noise Considerations in Section 4 of this manual.

Each Opto Output is programmed in the Output programming block.

Figure 2-25 Opto-isolated Output Configurations

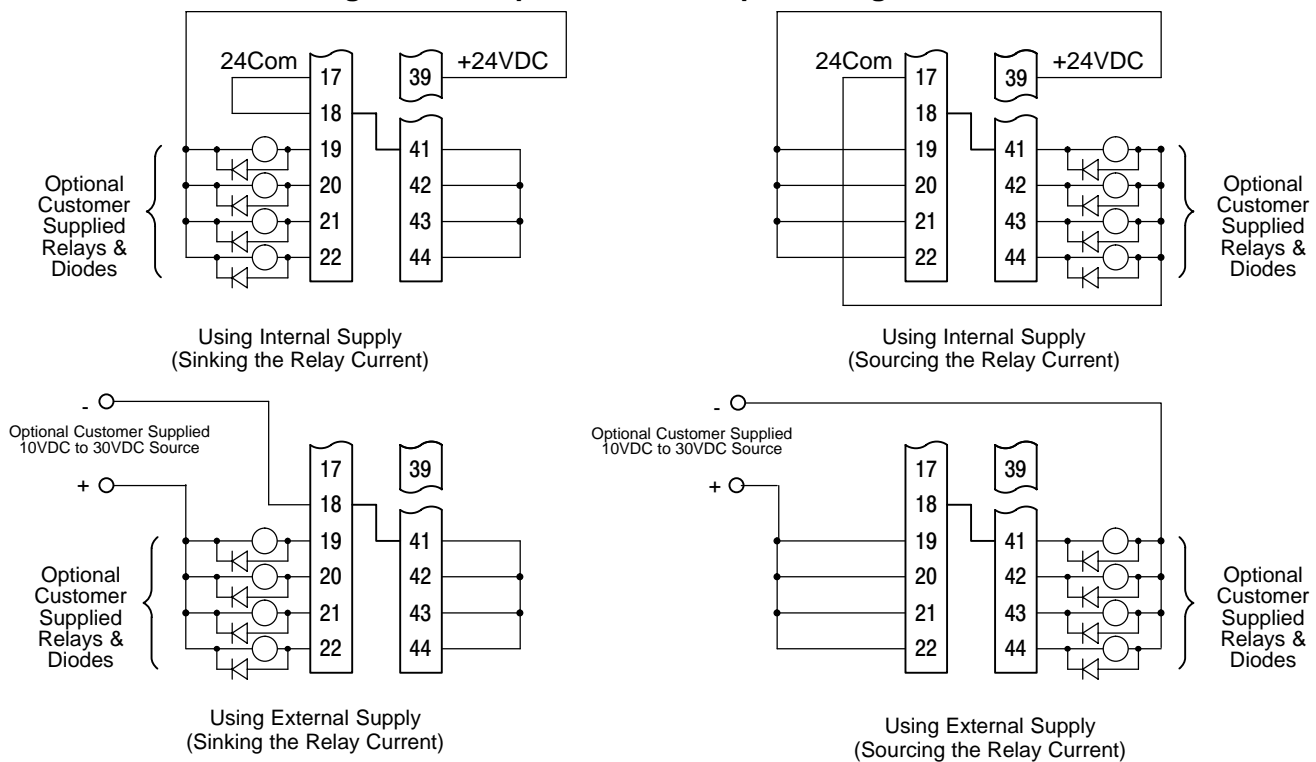

Terminal Tightening Torque = 7 Lb-in (0.8 Nm).

Figure 2-26 Opto-Output Equivalent Circuit

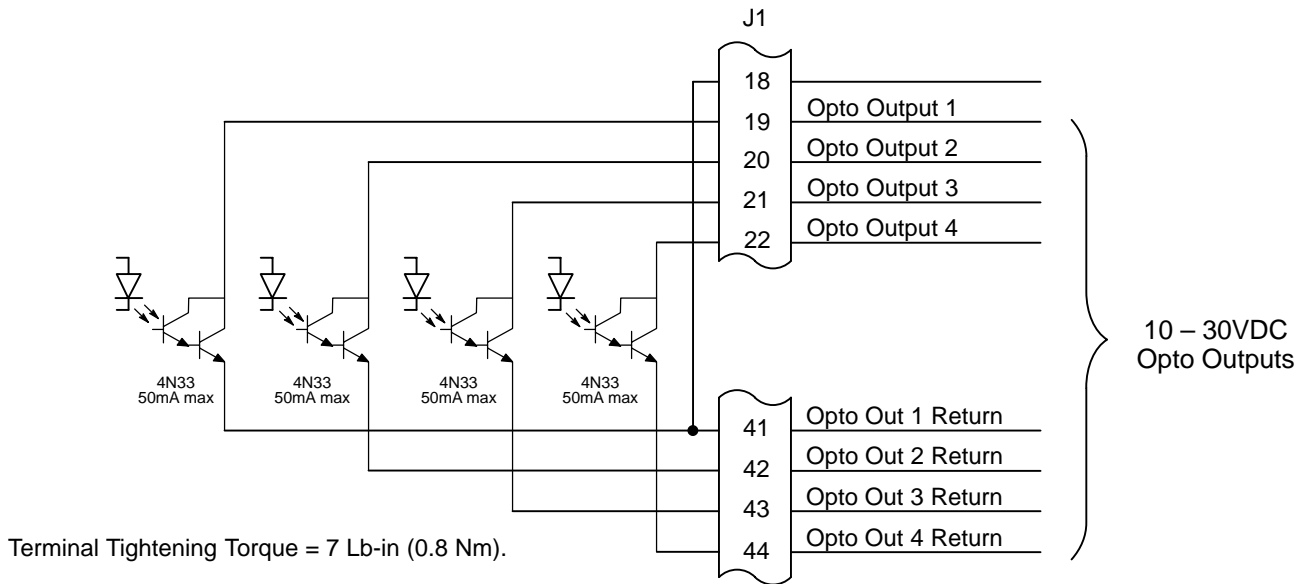

Pre-Operation Checklist

Check of Electrical Items

1. Verify AC line voltage at source matches control rating.
2. Inspect all power connections for accuracy, workmanship and tightness and compliance to codes.
3. Verify control and motor are grounded to each other and the control is connected to earth ground.
4. Check all signal wiring for accuracy.
5. Be certain all brake coils, contactors and relay coils have noise suppression. This should be an R-C filter for AC coils and reverse polarity diodes for DC coils. MOV type transient suppression is not adequate.

Check of Motors and Couplings

1. Verify freedom of motion of motor shaft.
2. Verify the motor coupling is tight without backlash.
3. Verify the holding brakes if any, are properly adjusted to fully release and set to the desired torque value.

Power-Up Procedure

This procedure will help get your system up and running in the keypad mode quickly and allow you to prove the motor and control operation. This procedure assumes that the control and motor are correctly installed and that you have an understanding of the keypad programming & operation procedures. It is not necessary to wire the terminal strip to operate the motor in the Keypad mode.

Initial Conditions

Be sure the control and motor are wired according to the procedures described previously in this section. Become familiar with the keypad programming and keypad operation of the control as described in Section 3 of this manual.

1. Verify that any enable inputs to J1-8 are open.
2. Turn power on. Be sure there are no faults.
3. Set the Level 1 Input block, Operating Mode to "KEYPAD".
4. Enter the following motor data in the Level 2 Motor Data block parameters:
Armature Voltage
ARM Rated Amps
Motor Rated Speed
Motor Field (Shunt or Permanent Magnet)
Motor Field Volts
Motor Field Amps
5. Set the feedback type to Armature, Encoder, Resolver or Tachometer in the Level 2 Motor Data block, Feedback Type parameter.
6. If feedback type is Armature, skip this step.
If Encoder, Tachometer or Resolver feedback type was selected, set one of the following corresponding Level 2 Motor Data block parameters:
Encoder Counts (ppr)
Resolver Speed
Tachometer Volts (VDC per 1000 RPM)

⚠ WARNING: The motor shaft will rotate during this procedure. Be certain that unexpected motor shaft movement will not cause injury to personnel or damage to equipment.

7. Go to Level 2 Autotune block, press ENTER, at CALC PRESETS select YES (using the ▲ key) and let the control calculate preset values for the parameters that are necessary for control operation.
8. Disconnect all input power.
9. Disconnect the motor from the load (including coupling or inertia wheels). If the load cannot be disconnected, do not perform the Feedback tests in step 11.
10. Connect input power.
11. Go to Level 2 Autotune block, and do the following tests:
CMD OFFSET TRIM
CUR LOOP COMP
FEEDBACK TESTS (Only if load is disconnected)
12. Set the Level 2 Output Limits block, "MIN OUTPUT SPEED" parameter.
13. Set the Level 2 Output Limits block, "MAX OUTPUT SPEED" parameter.
14. Disconnect all input power.
15. Couple the motor to its load.
16. Connect input power.
17. Go to Level 2 Autotune block, and perform the SPD CNTRLR CALC test.
18. Run the drive from the keypad using one of the following: the arrow keys for direct speed control, a keypad entered speed or the JOG mode.
19. Select additional parameters to customize the control to the application (MAX SPEED, etc.).

The control is now ready for use the in keypad mode. If a different operating mode is desired, refer to Section 3 Control Connections and Section 4 Programming and Operation.

Section 3

Programming and Operation

Overview

The keypad is used to program the control parameters, operate the motor and monitor the status and outputs of the control by accessing the display options, diagnostic menus and the fault log.

Figure 3-1 Keypad

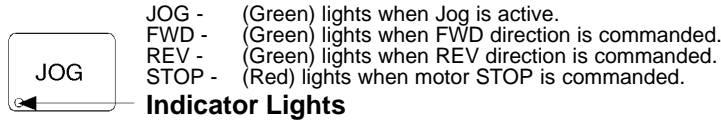

JOG - Press JOG to select the preprogrammed jog speed. After the jog key has been pressed, use the FWD or REV keys to run the motor in the direction that is needed. The JOG key is only active in the local mode.

FWD - Press FWD to initiate forward rotation of the motor. This key is only active in the Keypad or local mode.

REV - Press REV to initiate reverse rotation of the motor. This key is active only in the Keypad or local mode.

STOP - Press STOP one time to initiate a stop sequence. Depending on the setup of the control, the motor will either ramp or coast to a stop. This key is operational in all modes of operation unless it has been disabled by the Keypad Stop parameter in the Keypad (programming) Setup Block. Press STOP twice to disable control (coast to stop).

Note: If the control is operating in remote mode and the stop key is pressed the control will change to the local mode when the stop command is initiated. To resume operation in the remote mode, press the LOCAL key.

LOCAL - Press LOCAL to change between the local (keypad) and remote operation. When the control is in the local mode all other external commands to the J1 terminal strip will be ignored with the exception of the external trip input.

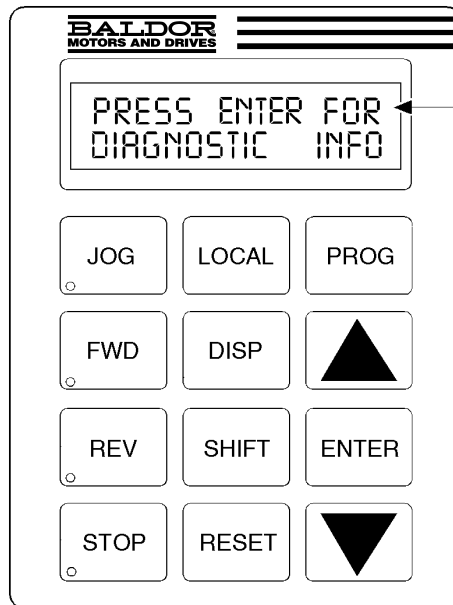

Keypad Display - Displays status information during Local or Remote operation. It also displays information during parameter setup and fault or Diagnostic Information.

PROG - Press PROG to enter the program mode. While in the program mode the PROG key is used to edit a parameter setting.

▲ - (UP Arrow).
 Press ▲ to change the value of the parameter being displayed. Pressing ▲ increments the value to the next greater value. Also, when the fault log or parameter list is displayed, the ▲ key will scroll upward through the list. In the local mode pressing the ▲ key will increase motor speed to the next greater value.

ENTER - Press ENTER to save parameter value changes and move back to the previous level in the programming menu. In the display mode the ENTER key is used to directly set the local speed reference. It is also used to select other operations when prompted by the keypad display.

▼ - (Down Arrow)
 Press ▼ to change the value of the parameter being displayed. Pressing ▼ decrements the value to the next lesser value. Also, when the fault log or parameter list is displayed, the ▼ key will scroll downward through the list. In the local mode pressing the ▼ key will decrease motor speed to the next lower value.

DISP - Press DISP to return to display mode from programming mode. Provides operational status and advances to the next display menu item including the diagnostic screens.

SHIFT - Press SHIFT in the program mode to control cursor movement. Pressing the SHIFT key once moves the blinking cursor one character position to the right. While in program mode, a parameter value may be reset to the factory preset value by pressing the SHIFT key until the arrow symbols at the far left of the keypad display are flashing, then press an arrow key. In the display mode the SHIFT key is used to adjust the keypad contrast.

RESET - Press RESET to clear all fault messages (in local mode). Can also be used to return to the top of the block programming menu without saving any parameter value changes.

Display Mode

The control is in the DISPLAY MODE at all times except when parameter values are changed (Programming mode). The Keypad Display shows the status of the control as in the following example.



The DISPLAY MODE is used to view DIAGNOSTIC INFO and the FAULT LOG. The description of how to do these tasks are described on the following pages.

Adjusting Display Contrast When AC power is applied to the control the keypad should display the status of the control. If there is no visible display, use the following procedure to adjust the contrast of the display.

(Contrast may be adjusted in display mode when motor is stopped or running)

Action	Description	Display	Comments
Apply Power	No visible display	BLANK	
Press DISP Key	Places control in display mode	BLANK	
Press SHIFT SHIFT	Allows display contrast adjustment	ADJUST CONTRAST ⬇ (ENTER) TO SAVE	
Press ▲ or ▼ Key	Adjusts display intensity	ADJUST CONTRAST ⬇ (ENTER) TO SAVE	
Press ENTER	Saves level of contrast and exits to display mode	STOP MOTOR SPEED LOCAL 0 RPM	Typical display

Display Mode Continued

Display Mode Screens

Action	Description	Display	Comments
Apply Power		<pre>BALDOR MOTORS & DRIVES</pre>	Logo display for 5 seconds.
	Display mode showing motor speed.	<pre>STOP MOTOR SPEED LOCAL 0 RPM</pre>	No faults present. Local keypad mode. If in remote/serial mode, press local for this display.
Press DISP key	Display Current	<pre>STOP CURRENT OUT LOCAL 0.00 A</pre>	
Press DISP key	Display Voltage	<pre>STOP VOLTAGE OUT LOCAL 0 V</pre>	
Press DISP key	Combined Display	<pre>STP 0 V 0 RPM LOC 0.0 A 0.0 XX</pre>	
Press DISP key	Screen to enter Fault Log	<pre>PRESS ENTER FOR FAULT LOG</pre>	
Press DISP key	Screen to enter Diagnostic Menu	<pre>PRESS ENTER FOR DIAGNOSTIC INFO</pre>	
Press DISP key	Exit Display mode and return to Motor Speed display	<pre>STOP MOTOR SPEED LOCAL 0 RPM</pre>	

Display Mode Continued





Display Screens & Diagnostic Information Access

Action	Description	Display	Comments
Apply Power		BALDOR MOTORS & DRIVES	Logo display for 5 seconds.
	Display mode showing motor speed.	STOP MOTOR SPEED LOCAL 0 RPM	No faults present. Local keypad mode. If in remote/serial mode, press local for this display.
Press DISP key 5 times	Scroll to Diagnostic Information screen	PRESS ENTER FOR DIAGNOSTIC INFO	Diagnostic Access screen.
Press ENTER key	Access diagnostic information.	STOP SPEED REF LOCAL 0 RPM	First Diagnostic Information screen.
Press DISP key	Display mode showing control temperature.	STOP CONTROL TEMP LOCAL 0.0° C	
Press DISP key	Display mode showing % overload current remaining.	STOP OVRLD LEFT LOCAL 100.00%	
Press DISP key	Display mode showing opto inputs & outputs states. 0=Open, 1=Closed	DIGITAL I/O 00000000 0000	Opto Inputs states (Left); Opto Outputs states (Right).
Press DISP key	Display mode showing actual drive running time.	TIME FROM PUR UP 0000000.01.43	HR.MIN.SEC format.
Press DISP key	Display mode showing operating mode, voltage and control type.	100HP REGEN 460V DIGITAL DC	
Press DISP key	Display mode showing continuous amps; PK amps rating; amps/volt scale of feedback, power base ID.	X.XA APK X.XX A/V ID:XXX	ID is displayed as a hexadecimal value.
Press DISP key	Display mode showing which Group1 or 2 expansion boards are installed.	G1 DC TACHOMETER G2 NOT INSTALLED	
Press DISP key	Display mode showing motor shaft revolutions from the REV home set point.	POSITION COUNTER + 000:00000 REV	
Press DISP key	Display mode showing firmware version and revision installed in the control.	SOFTWARE VERSION XXX-X.XX	
Press DISP key	Displays exit choice.	PRESS ENTER FOR DIAGNOSTIC EXIT	Press ENTER to exit diagnostic information.

Display Mode Continued

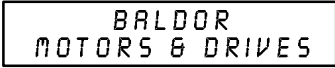
Fault Log Access

When a fault condition occurs, motor operation stops and a fault code is displayed on the Keypad display. The control keeps a log of up to the last 31 faults. If more than 31 faults have occurred the oldest fault will be deleted from the fault log to make room for the newest fault. To access the fault log perform the following procedure:

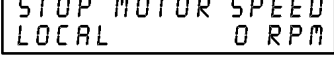
Action	Description	Display	Comments
Apply Power			Logo display for 5 seconds.
	Display mode showing motor speed.		Display mode.
Press DISP key 4 times	Scroll to the Fault Log screen		Fault Log access screen.
Press ENTER key	Display first fault type and time fault occurred.		Most recent fault displayed.
Press ▲ key	Scroll through fault messages.		If no messages, the fault log exit choice is displayed.
Press ENTER key	Return to display mode.		Display mode stop key LED is on.

Program Mode

The Program Mode is used to:

1. Enter motor data.
2. Autotune the motor.
3. Customize the drive (Control and Motor) parameters to your application.

From the Display Mode press the PROG key to access the Program Mode.

Note: When a parameter is selected, alternately pressing the Disp and Prog keys will toggle between the Display Mode and the selected parameter. When a parameter is selected for programming, the keypad display gives you the following information:

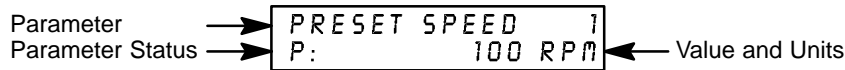

Parameter Status. All programmable parameters are displayed with a “P:” in the lower left corner of the keypad display. If a parameter is displayed with a “V:”, the parameter value may be viewed but not changed while the motor is operating. If the parameter is displayed with an “L:”, the value is locked and the security access code must be entered before its’ value can be changed.

Parameter Blocks Access for Programming

Use the following procedure to access parameter blocks to program the control.

Action	Description	Display	Comments
Apply Power	Keypad Display shows this opening message.	<pre>BALDOR MOTORS & DRIVES</pre>	Logo display for 5 seconds.
	If no faults and programmed for LOCAL operation.	<pre>STOP MOTOR SPEED LOCAL 0 RPM</pre>	Display mode.
	If no faults and programmed for REMOTE operation.	<pre>OFF MOTOR SPEED REMOTE 0 RPM</pre>	If fault is displayed, refer to the Troubleshooting section of this manual.
Press PROG key		<pre>PRESS ENTER FOR PRESET SPEEDS</pre>	Press ENTER to access Preset Speed parameters.
Press ▲ or ▼ key	Scroll to the ACCEL/DECEL block.	<pre>PRESS ENTER FOR ACCEL/DECEL RATE</pre>	Press ENTER to access Accel and Decel rate parameters.
Press ▲ or ▼ key	Scroll to the Level 2 Block.	<pre>PRESS ENTER FOR LEVEL 2 BLOCKS</pre>	Press ENTER to access Level 2 Blocks.
Press ENTER key	First Level 2 block display.	<pre>PRESS ENTER FOR OUTPUT LIMITS</pre>	
Press ▲ or ▼ key	Scroll to Programming Exit menu.	<pre>PRESS ENTER FOR PROGRAMMING EXIT</pre>	Press ENTER to return to Display mode.
Press ENTER key	Return to display mode.	<pre>STOP MOTOR SPEED LOCAL 0 RPM</pre>	

Program Mode Continued

Changing Parameter Values when Security Code Not Used

Use the following procedure to program or change a parameter already programmed into the control when a security code is not being used.

The example shown changes the operating mode from Keypad to Bipolar.

Action	Description	Display	Comments
Apply Power	Keypad Display shows this opening message.	<pre>BALDOR MOTORS & DRIVES</pre>	Logo display for 5 seconds.
	If no faults and programmed for LOCAL operation.	<pre>STOP MOTOR SPEED LOCAL 0 RPM</pre>	Display mode. Stop LED on.
Press PROG key	Access programming mode.	<pre>PRESS ENTER FOR PRESET SPEEDS</pre>	
Press ▲ or ▼ key	Scroll to Level 1 Input Block.	<pre>PRESS ENTER FOR INPUT</pre>	Press ENTER to access INPUT block parameter.
Press ENTER key	Access Input Block.	<pre>OPERATING MODE P: KEYPAD</pre>	Keypad mode shown is the factory setting.
Press ENTER key	Access Operating Mode parameter.	<pre>OPERATING MODE ◆ □ KEYPAD</pre>	Keypad mode shown is the factory setting.
Press ▲ key	Scroll to change selection.	<pre>OPERATING MODE ◆ □ BIPOLAR</pre>	At flashing cursor, select desired mode, BIPOLAR in this case.
Press ENTER	Save selection to memory.	<pre>OPERATING MODE P: BIPOLAR</pre>	Press ENTER to save selection.
Press ▲ key	Scroll to menu exit.	<pre>PRESS ENTER FOR MENU EXIT</pre>	
Press ENTER key	Return to Input Block.	<pre>PRESS ENTER FOR INPUT</pre>	
Press DISP key	Return to Display Mode.	<pre>STOP MOTOR SPEED LOCAL 0 RPM</pre>	Typical display mode.

Program Mode Continued

Reset Parameters to Factory Settings

Sometimes it is necessary to restore the parameter values to the factory settings. Follow this procedure to do so. Be sure to change the Level 2 Motor Data block "Motor Rated Amps" to the correct value after this procedure (restored factory setting is 999).

Note: All specific application parameters already programmed will be lost when resetting the control to factory settings.

Note: After factory settings are restored, the drive must be auto tuned.

Action	Description	Display	Comments
Apply Power	Keypad Display shows this opening message.	<pre>BALDOR MOTORS & DRIVES</pre>	Logo display for 5 seconds.
	If no faults and programmed for LOCAL operation.	<pre>STOP MOTOR SPEED LOCAL 0 RPM</pre>	Display mode. Stop LED on.
Press PROG key	Enter program mode.	<pre>PRESS ENTER FOR PRESET SPEEDS</pre>	
Press ▲ or ▼ key	Scroll to Level 2 Blocks.	<pre>PRESS ENTER FOR LEVEL 2 BLOCKS</pre>	
Press ENTER key	Select Level 2 Blocks.	<pre>PRESS ENTER FOR OUTPUT LIMITS</pre>	
Press ▲ or ▼ key	Scroll to the Miscellaneous block.	<pre>PRESS ENTER FOR MISCELLANEOUS</pre>	
Press ENTER key	Select Miscellaneous block.	<pre>RESTART AUTO/MAN P: MANUAL</pre>	
Press ▲ key	Scroll to Factory Settings parameter.	<pre>FACTORY SETTINGS P: NO</pre>	
Press ENTER key	Access Factory Settings parameter.	<pre>FACTORY SETTINGS \updownarrow <input type="checkbox"/> NO</pre>	<input type="checkbox"/> represents blinking cursor.
Press ▲ key	Scroll to YES, to choose original factory settings.	<pre>FACTORY SETTINGS \updownarrow <input type="checkbox"/> YES</pre>	
Press ENTER key	Restores factory settings.	<pre>FACTORY SETTINGS P:LOADING PRESETS</pre>	"Loading Presets" is first message "Operation Done" is next "No" is displayed last.
Press ▲ key	Scroll to menu exit.	<pre>PRESS ENTER FOR MENU EXIT</pre>	Exit Level 2 blocks.
Press ▲ or ▼ key	Scroll to Programming exit.	<pre>PRESS ENTER FOR PROGRAMMING EXIT</pre>	Exit Programming mode and return to Display mode.
Press ENTER key	Return to display mode.	<pre>STOP MOTOR SPEED LOCAL 0 RPM</pre>	Display mode. Stop LED on.

Program Mode Continued

Initialize New Firmware

After new firmware is installed, the control must be initialized to the new firmware version and memory locations. Use the following procedure to Initialize the firmware.

Note: All specific application parameters already programmed will be lost when resetting the control to factory settings.

Note: After factory settings have been restored, the drive must be auto tuned.

Action	Description	Display	Comments
Apply Power	Keypad Display shows this opening message.	<pre>BALDOR MOTORS & DRIVES</pre>	Logo display for 5 seconds.
	If no faults and programmed for LOCAL operation.	<pre>STOP MOTOR SPEED LOCAL 0 RPM</pre>	Display mode. Stop LED on.
Press PROG key	Enter program mode.	<pre>PRESS ENTER FOR PRESET SPEEDS</pre>	
Press ▲ or ▼ key	Scroll to Level 2 Blocks.	<pre>PRESS ENTER FOR LEVEL 2 BLOCKS</pre>	
Press ENTER key	Select Level 2 Blocks.	<pre>PRESS ENTER FOR OUTPUT LIMITS</pre>	
Press ▲ or ▼ key	Scroll to the Miscellaneous block.	<pre>PRESS ENTER FOR MISCELLANEOUS</pre>	
Press ENTER key	Select Miscellaneous block.	<pre>RESTART AUTO/MAN P: MANUAL</pre>	
Press ▲ key	Scroll to Factory Settings parameter.	<pre>FACTORY SETTINGS P: NO</pre>	
Press ENTER key	Access Factory Settings parameter.	<pre>FACTORY SETTINGS ⬆️ □ NO</pre>	□ represents blinking cursor.
Press ▲ key	Scroll to YES, to choose original factory settings.	<pre>FACTORY SETTINGS ⬆️ □ YES</pre>	
Press ENTER key	Restores factory settings.	<pre>FACTORY SETTINGS P:LOADING PRESETS</pre>	"Loading Presets" is first message "Operation Done" is next "No" is displayed last.
Press ▲ key	Scroll to menu exit.	<pre>PRESS ENTER FOR MENU EXIT</pre>	
Press ENTER key	Return to display mode.	<pre>STOP MOTOR SPEED LOCAL 0 RPM</pre>	Display mode. Stop LED on.
Press DISP key several times	Scroll to diagnostic information screen.	<pre>PRESS ENTER FOR DIAGNOSTIC INFO</pre>	If you wish to verify the firmware version, enter diagnostic info.
Press ENTER key	Access diagnostic information.	<pre>STOP SPEED REF LOCAL 0 RPM</pre>	Displays commanded speed, direction of rotation, Local/Remote and motor speed.
Press DISP key	Display mode showing firmware version and revision installed in the control.	<pre>SOFTWARE VERSION XXX-X.XX</pre>	Verify new firmware version.
Press DISP key	Displays exit choice.	<pre>PRESS ENTER FOR DIAGNOSTIC EXIT</pre>	Press ENTER to exit diagnostic information.

Operating the Control from the Keypad

If the control is configured for remote or serial control, the LOCAL MODE must be activated before the control may be operated from the keypad. To activate the LOCAL MODE, first the motor must be stopped via the keypad, remote or serial commands. When the motor has stopped, the LOCAL MODE is activated by pressing the LOCAL key. Selection of the LOCAL MODE overrides any remote or serial control inputs except for the External Trip input, J1-16.

Note: If the control has been configured, via parameter settings, for KEYPAD MODE, then no other means of operation are permitted other than the keypad.

From the keypad, the control can operate the motor in three ways; keypad entered speed adjustments, Arrow key speed adjustment, or JOG mode commands.

Keypad entered speed adjustments

Action	Description	Display	Comments
Apply Power	Keypad Display shows this opening message.	<pre>BALDOR MOTORS & DRIVES</pre>	Logo display for 5 seconds.
	If no faults and programmed for LOCAL operation.	<pre>STOP MOTOR SPEED LOCAL 0 RPM</pre>	Display mode. Stop LED on.
Press FWD or REV key	Commands forward or reverse motor operation at selected speed.	<pre>FWD MOTOR SPEED LOCAL 0 RPM</pre>	FWD or REV LED on.
Press ENTER key	Access speed adjustment.	<pre>MOTOR SPEED 00000 0 RPM</pre>	Speed adjustment display. □ represents blinking cursor.
Press SHIFT key	Move cursor right one digit.	<pre>MOTOR SPEED 00000 0 RPM</pre>	
Press ▲ key	Increase value of 2nd digit.	<pre>MOTOR SPEED 01000 0 RPM</pre>	
Press ENTER key	Save new value and return to previous display.	<pre>STOP MOTOR SPEED LOCAL 0 RPM</pre>	
Press FWD or REV key	Commands forward or reverse motor operation at selected speed.	<pre>FWD MOTOR SPEED LOCAL 1000 RPM</pre>	
Press STOP key	Commands motor to decelerate.	<pre>STOP MOTOR SPEED LOCAL 0 RPM</pre>	STOP LED is ON when motor reaches 0 RPM.

Operating the Control from the Keypad Continued

Arrow key speed adjustments

Action	Description	Display	Comments
Apply Power	Keypad Display shows this opening message.	<pre>BALDOR MOTORS & DRIVES</pre>	Logo display for 5 seconds.
	If no faults and programmed for LOCAL operation.	<pre>STOP MOTOR SPEED LOCAL 0 RPM</pre>	Display mode. Stop LED on.
Press FWD or REV key	Commands forward or reverse motor operation at selected speed.	<pre>FWD MOTOR SPEED LOCAL 0 RPM</pre>	FWD or REV LED on.
Press ▲ key	Increase motor speed.	<pre>FWD MOTOR SPEED LOCAL 1000 RPM</pre>	
Press ▼ key	Decrease motor speed.	<pre>FWD MOTOR SPEED LOCAL 500 RPM</pre>	
Press STOP key	Commands motor to decelerate.	<pre>STOP MOTOR SPEED LOCAL 0 RPM</pre>	STOP LED is ON when motor reaches 0 RPM.
Press FWD or REV key	Commands forward or reverse motor operation at selected speed.	<pre>FWD MOTOR SPEED LOCAL 500 RPM</pre>	Motor speed increases to previous set speed.

Operating the Control from the Keypad Continued

JOG mode commands

Action	Description	Display	Comments
Apply Power	Keypad Display shows this opening message.	<div style="border: 1px solid black; padding: 2px; text-align: center;"> BALDOR MOTORS & DRIVES </div>	Logo display for 5 seconds.
	If no faults and programmed for LOCAL operation.	<div style="border: 1px solid black; padding: 2px; text-align: center;"> STOP MOTOR SPEED LOCAL 0 RPM </div>	Display mode. Stop LED is on.
Press JOG key	Enable JOG mode (speed is set in the Level 1 Jog Settings block, JOG Speed parameter value).	<div style="border: 1px solid black; padding: 2px; text-align: center;"> STOP MOTOR SPEED LOCAL 0 RPM </div>	JOG LED is on.
Press and hold FWD or REV key	Increase motor speed.	<div style="border: 1px solid black; padding: 2px; text-align: center;"> FWD MOTOR SPEED LOCAL 200 RPM </div>	Motor runs at programmed JOG speed while FWD or REV key is depressed. JOG LED is on.
Press STOP key	Commands motor to decelerate.	<div style="border: 1px solid black; padding: 2px; text-align: center;"> STOP MOTOR SPEED LOCAL 0 RPM </div>	STOP LED is ON when motor reaches 0 RPM.

Parameter Definitions

To make programming easier, parameters have been arranged into the two level structure shown in Table 3-1. Press the PROG key to enter the programming mode and the "Preset Speeds" programming block will be displayed. Use the Up (▲) and Down (▼) arrows to scroll through the parameter blocks. Press ENTER to access parameters within a programming block.

Tables 3-2 and 3-3 provide an explanation of each parameter. A complete Parameter Block Values list is located at the end of this manual. This list defines the programmable range and factory preset value for each parameter. The list has a space to record your settings for future reference.

Table 3-1 List of Parameters

LEVEL 1 BLOCKS		LEVEL 2 BLOCKS	
Preset Speeds	Input	Output Limits	Motor Data
Preset Speed #1	Operating Mode	Operating Zone	Armature Voltage
Preset Speed #2	Command Select	Min Output Speed	ARM Rated Amps
Preset Speed #3	ANA CMD Inverse	Max Output Speed	Motor Rated SPD
Preset Speed #4	ANA CMD Offset	PK Current Limit	Motor Field
Preset Speed #5	ANA 2 Deadband	CUR Rate Limit	Motor Field Volts
Preset Speed #6			Motor Field Amps
Preset Speed #7	Output		Feedback Type
Preset Speed #8	Opto Output #1	Custom Units	Encoder Counts
Preset Speed #9	Opto Output #2	Decimal Places	Resolver Speed
Preset Speed #10	Opto Output #3	Value at Speed	Tachometer Volts
Preset Speed #11	Opto Output #4	Units of Measure	PK Power Limit
Preset Speed #12	Zero SPD Set PT		
Preset Speed #13	At Speed Band	Protection	Process Control
Preset Speed #14	Set Speed	Overload	Process Feedback
Preset Speed #15	Analog Out #1	External Trip	Process Inverse
	Analog Out #2	Following Error	Setpoint Source
Accel / Decel Rate	Analog #1 Scale	Torque Proving	Setpoint Command
Accel Time #1	Analog #2 Scale		Set PT ADJ Limit
Decel Time #1	Position Band	Miscellaneous	Process ERR TOL
S-Curve #1		Restart Auto/Man	Process PROP Gain
Accel Time #2	DC Control	Restart Fault/Hr	Process INT Gain
Decel Time #2	Ctrl Base Volts	Restart Delay	Process DIFF Gain
S-Curve #2	Feedback Filter	Factory Settings	Follow I:O Ratio
	Feedback Dir	Homing Speed	Follow I:O Out
Jog Settings	ARM PROP Gain	Homing Offset	Master Encoder
Jog Speed	ARM INT Gain		
Jog Accel Time	Speed PROP Gain	Security Control	Auto-Tuning
Jog Decel Time	Speed INT Gain	Security State	CALC Presets
Jog S-Curve Time	Speed DIFF Gain	Access Timeout	CMD Offset Trim
	Position Gain	Access Code	CUR Loop Comp
Keypad Setup	IR COMP Gain		Feedback Tests
Keypad Stop Key	TACH Trim		SPD CNTRLR CALC
Keypad Stop Mode	Null Force Gain		
Keypad Run Fwd			
Keypad Run Rev	Field Control		
Keypad Jog Fwd	Field PWR Supply		
Keypad Jog Rev	Field ECON Level		
	Forcing Level		
	Field Set Speed		
	Field Step Limit		
	Field REG Gain		

Table 3-2 Level 1 Parameter Block Definitions

Block Title	Parameter	Description
PRESET SPEEDS	Preset Speeds #1 - #15	Allows selection of 15 predefined motor operating speeds. Each speed may be selected using external switches connected to J1-11, J1-12, J1-13 and J1-14 when Operating Mode is set to 15 Speed. For motor operation, a motor direction command must be given along with a preset speed command.
ACCEL/DECCEL RATE	Accel Time #1,2 Decel Time #1,2 S-Curve #1,2	Accel time is the number of seconds required for the motor to increase at a linear rate from 0 RPM to the RPM specified in the "Max Output Speed" parameter in the Level 2 Output Limits block. Decel time is the number of seconds required for the motor to decrease at a linear rate from the speed specified in the "Max Output Speed" parameter to 0 RPM. S-Curve is a percentage of the total Accel and Decel time and provides smooth starts and stops. Half of programmed S-Curve % applies to Accel and half to Decel ramps. 0% represents no "S" and 100% represents full "S" with no linear segment. Note: Accel #1, Decel #1 and S-Curve #1 are associated together. Likewise, Accel #2, Decel #2 and S-Curve #2 are associated together. These associations can be used to control any Preset Speed or External Speed command. Note: If drive faults occur during rapid Accel or Decel, selecting an S-curve may eliminate the faults.
JOG SETTINGS	Jog Speed Jog Accel Time Jog Decel Time Jog S-Curve	Jog Speed is the programmed speed used during for jog. Jog can be initiated from the keypad or terminal strip. At the Keypad, press the JOG key then press and hold the direction (FWD or REV). At the terminal strip, close the direction input (J1-9 or J1-10) then close the JOG input (J1-12). To cause motor to operate at Jog Speed the FWD or REV key must be pressed and held or external command Forward (J1-9) or Reverse (J1-10). Jog Accel Time changes the Accel Time to a new preset value for jog mode. Jog Decel Time changes the Decel Time to a new preset value for jog mode. Jog S-Curve changes the S-Curve to a new preset value for jog mode.

Figure 3-2 40% S-Curve Example



Table 3-2 Level 1 Parameter Block Definitions - Continued

Block Title	Parameter	Description
KEYPAD SETUP	Keypad Stop Key	Stop Key - Allows keypad "STOP" key to initiate motor stop during remote or serial operation (if Stop key is set to Remote ON). If active, pressing "STOP" automatically selects Local mode and initiates the stop command.
	Keypad Stop Mode	Stop Mode - Selects if the Stop command causes the motor to "COAST" to a stop or "REGEN" to a stop. In COAST, the motor is turned off and allowed to coast to a stop. In REGEN, the voltage and frequency to the motor is reduced at a rate set by "Decel Time".
	Keypad Run FWD	Run FWD - ON makes the keypad "FWD" key active in Local mode.
	Keypad Run REV	Run REV - ON makes the keypad "REV" key active in Local mode.
	Keypad Jog FWD	Jog FWD - ON makes the keypad "FWD" key active in Local Jog mode.
	Keypad Jog REV	Jog REV - ON makes the keypad "REV" key active in Local Jog mode.
INPUT	Operating Mode	Six "Operating Modes" are available. Choices are: Keypad, Standard Run, 15SPD, Serial, Bipolar, Process, Bipolar Hoist and 7 Speed Hoist. External connections to the control are made at the J1 terminal strip (wiring diagrams are shown in Section 2 "Control Circuit Connections").
	Command Select	<p>Selects the external speed reference to be used. The easiest method of speed control is to select POTENTIOMETER and connect a 5KΩ pot to J1-1, J1-2, and J1-3. ± 5, ± 10VDC or 4-20mA input command can be applied to J1-4 and J1-5.</p> <p>If long distance is required between the external speed control and the control, the 4-20mA selections at J1-4 and J1-5 should be considered. Current loop allows long cable lengths without attenuation of the command signal.</p> <p>10VOLT W/EXT CL - when a 10V differential command is present at J1-4 and 5, allows an additional 5V input at J1-1, 2 and 3 which allows reduction in programmed current limit for torque trimming during operation.</p> <p>10 VOLT W/TORQ FF - when a differential command is present at J1-4 and 5, allows additional 5V torque feedforward input at J1-1, 2 and 3 to set a predetermined amount of torque inside the rate loop with high gain settings.</p> <p>EXB PULSE FOL - selects optional Master Pulse Reference/Isolated Pulse Follower expansion board if installed.</p> <p>10VOLT EXB - selects optional High Resolution I/O expansion board if installed.</p> <p>3-15 PSI EXB selects optional 3-15 PSI expansion board if installed.</p> <p>Tachometer EXB- selects optional DC Tachometer expansion board if installed.</p> <p>Serial -selects optional Serial Communications expansion board if installed.</p> <p>Note: When using the 4-20mA input, the JP1 jumper on the main control board must be moved to pins 2 and 3.</p>
	ANA CMD Inverse	<p>"OFF" will cause a low input voltage (e.g. 0VDC) to be a low motor speed command and a maximum input voltage (e.g. 10VDC) to be a maximum motor speed command.</p> <p>"ON" will cause a low input voltage (e.g. 0VDC) to be a maximum motor speed command and a maximum input voltage (e.g. 10VDC) to be a low motor speed command.</p>
	ANA CMD Offset	Provides an offset to the Analog Input to minimize signal drift. For example, if the minimum speed signal is 1VDC (instead of 0VDC) the ANA CMD Offset can be set to -10% so the minimum voltage input is seen by control as 0VDC.
	ANA 2 Deadband	Allows a voltage threshold to be defined. A command signal level below this voltage will not affect the control output.

Table 3-2 Level 1 Parameter Block Definitions - Continued

Block Title	Parameter	Description																																				
OUTPUT	OPTO OUTPUT #1 - #4	<p>Four optically isolated digital outputs that have two operating states, logical High or Low. Each output may be configured to any of the following conditions:</p> <table border="0"> <thead> <tr> <th data-bbox="570 373 683 405">Condition</th> <th data-bbox="781 373 911 405">Description</th> </tr> </thead> <tbody> <tr> <td data-bbox="570 415 651 447">Ready -</td> <td data-bbox="781 415 1365 447">Active when power is applied and no faults are present.</td> </tr> <tr> <td data-bbox="570 457 699 489">Zero Speed -</td> <td data-bbox="781 457 1446 510">Active when output frequency to motor is below the value of the Level 1 Output "Zero SPD Set Pt" parameter.</td> </tr> <tr> <td data-bbox="570 520 683 552">At Speed -</td> <td data-bbox="781 520 1446 573">Active when output speed is within the speed range defined by the Level 1 Output "At Speed Band" parameter.</td> </tr> <tr> <td data-bbox="570 583 716 615">At Set Speed -</td> <td data-bbox="781 583 1414 636">Active when output speed is at or above the Level 1 Output "Set Speed" parameter.</td> </tr> <tr> <td data-bbox="570 646 683 678">Overload -</td> <td data-bbox="781 646 1398 720">A normally closed contact that is active (opens) during an Overload fault caused by a time out when output current is greater than Rated Current.</td> </tr> <tr> <td data-bbox="570 730 748 762">Keypad Control -</td> <td data-bbox="781 730 1268 762">Active when control is in Local keypad control.</td> </tr> <tr> <td data-bbox="570 772 634 804">Fault -</td> <td data-bbox="781 772 1203 804">Active when a fault condition is present.</td> </tr> <tr> <td data-bbox="570 814 732 846">Following ERR -</td> <td data-bbox="781 814 1398 867">Active when the motor speed is outside the user specified tolerance band defined by the At Speed Band parameter.</td> </tr> <tr> <td data-bbox="570 877 748 909">Motor Direction -</td> <td data-bbox="781 877 1463 930">Active High when REV direction command received. Active Low when FWD direction command received.</td> </tr> <tr> <td data-bbox="570 940 683 972">Drive On -</td> <td data-bbox="781 940 1252 972">Active when control is Enabled and "Ready".</td> </tr> <tr> <td data-bbox="570 982 732 1014">CMD Direction -</td> <td data-bbox="781 982 1398 1035">Active at all times. Logical output state indicates Forward (Open) or Reverse (Closed) direction.</td> </tr> <tr> <td data-bbox="570 1045 699 1077">AT Position -</td> <td data-bbox="781 1045 1446 1098">Active during a positioning command when control is within the position band parameter tolerance.</td> </tr> <tr> <td data-bbox="570 1108 748 1140">Over Temp Warn -</td> <td data-bbox="781 1108 1398 1140">Active when control heat sink is within 3°C of Int Overtemp.</td> </tr> <tr> <td data-bbox="570 1150 732 1182">Process Error -</td> <td data-bbox="781 1150 1414 1245">Active when process feedback signal is outside the range specified by the Level 2 Process Control block, AT Setpoint Band parameter. Turns off when process feedback error is eliminated.</td> </tr> <tr> <td data-bbox="570 1255 683 1287">Drive Run -</td> <td data-bbox="781 1255 1463 1308">Active when drive is Ready, Enabled, Speed or Torque command received with FWD/REV direction issued.</td> </tr> <tr> <td data-bbox="570 1318 732 1350">Running Field -</td> <td data-bbox="781 1318 1463 1392">Active when field current is greater than 90% of the user programmed motor field amps. Could be used as a torque ready output.</td> </tr> <tr> <td data-bbox="570 1402 748 1434">M/FWD Contact -</td> <td data-bbox="781 1402 1463 1602">May be used to close an external motor armature contactor. This output is high when the control is ready and a forward or reverse command is issued. There is a 16ms delay between M/FWD CONTACT ON and when the control actually engages the output bridge. The delay helps compensate for any contactor bounce. The output turns OFF when forward and reverse are dropped and after the armature current is reduced to zero. Refer to Opto Output description of Section 2.</td> </tr> </tbody> </table>	Condition	Description	Ready -	Active when power is applied and no faults are present.	Zero Speed -	Active when output frequency to motor is below the value of the Level 1 Output "Zero SPD Set Pt" parameter.	At Speed -	Active when output speed is within the speed range defined by the Level 1 Output "At Speed Band" parameter.	At Set Speed -	Active when output speed is at or above the Level 1 Output "Set Speed" parameter.	Overload -	A normally closed contact that is active (opens) during an Overload fault caused by a time out when output current is greater than Rated Current.	Keypad Control -	Active when control is in Local keypad control.	Fault -	Active when a fault condition is present.	Following ERR -	Active when the motor speed is outside the user specified tolerance band defined by the At Speed Band parameter.	Motor Direction -	Active High when REV direction command received. Active Low when FWD direction command received.	Drive On -	Active when control is Enabled and "Ready".	CMD Direction -	Active at all times. Logical output state indicates Forward (Open) or Reverse (Closed) direction.	AT Position -	Active during a positioning command when control is within the position band parameter tolerance.	Over Temp Warn -	Active when control heat sink is within 3°C of Int Overtemp.	Process Error -	Active when process feedback signal is outside the range specified by the Level 2 Process Control block, AT Setpoint Band parameter. Turns off when process feedback error is eliminated.	Drive Run -	Active when drive is Ready, Enabled, Speed or Torque command received with FWD/REV direction issued.	Running Field -	Active when field current is greater than 90% of the user programmed motor field amps. Could be used as a torque ready output.	M/FWD Contact -	May be used to close an external motor armature contactor. This output is high when the control is ready and a forward or reverse command is issued. There is a 16ms delay between M/FWD CONTACT ON and when the control actually engages the output bridge. The delay helps compensate for any contactor bounce. The output turns OFF when forward and reverse are dropped and after the armature current is reduced to zero. Refer to Opto Output description of Section 2.
Condition	Description																																					
Ready -	Active when power is applied and no faults are present.																																					
Zero Speed -	Active when output frequency to motor is below the value of the Level 1 Output "Zero SPD Set Pt" parameter.																																					
At Speed -	Active when output speed is within the speed range defined by the Level 1 Output "At Speed Band" parameter.																																					
At Set Speed -	Active when output speed is at or above the Level 1 Output "Set Speed" parameter.																																					
Overload -	A normally closed contact that is active (opens) during an Overload fault caused by a time out when output current is greater than Rated Current.																																					
Keypad Control -	Active when control is in Local keypad control.																																					
Fault -	Active when a fault condition is present.																																					
Following ERR -	Active when the motor speed is outside the user specified tolerance band defined by the At Speed Band parameter.																																					
Motor Direction -	Active High when REV direction command received. Active Low when FWD direction command received.																																					
Drive On -	Active when control is Enabled and "Ready".																																					
CMD Direction -	Active at all times. Logical output state indicates Forward (Open) or Reverse (Closed) direction.																																					
AT Position -	Active during a positioning command when control is within the position band parameter tolerance.																																					
Over Temp Warn -	Active when control heat sink is within 3°C of Int Overtemp.																																					
Process Error -	Active when process feedback signal is outside the range specified by the Level 2 Process Control block, AT Setpoint Band parameter. Turns off when process feedback error is eliminated.																																					
Drive Run -	Active when drive is Ready, Enabled, Speed or Torque command received with FWD/REV direction issued.																																					
Running Field -	Active when field current is greater than 90% of the user programmed motor field amps. Could be used as a torque ready output.																																					
M/FWD Contact -	May be used to close an external motor armature contactor. This output is high when the control is ready and a forward or reverse command is issued. There is a 16ms delay between M/FWD CONTACT ON and when the control actually engages the output bridge. The delay helps compensate for any contactor bounce. The output turns OFF when forward and reverse are dropped and after the armature current is reduced to zero. Refer to Opto Output description of Section 2.																																					

Table 3-2 Level 1 Parameter Block Definitions - Continued

Block Title	Parameter	Description																																		
OUTPUT (Continued)	Zero SPD Set PT	Sets the speed at which the Zero Speed opto output becomes active (turns on). When the speed is less than the ZERO SPD SET PT, the Opto Output becomes active. This is useful when a motor brake is to interlock operation with a motor.																																		
	At Speed Band	<p>The At Speed Band serves two Opto Output Conditions and the Level 2 Protection block Following Error:</p> <p>Sets the speed range in RPM at which the At Speed opto output turns on and remains active within the range.</p> <p>Sets the Following Error Tolerance Band for the Level 1 OUTPUT, Opto Output condition Following ERR. The opto output is active if the motor speed is outside this band.</p> <p>Sets the no fault operating speed range of the drive. This value is used by the Level 2 Protection block, Following Error parameter (if it is set to ON). If the drive speed falls out of this band, the Level 2 Protection block, Following Error parameter will shut down the drive (if it is set to ON).</p>																																		
	Set Speed	Sets the speed that the AT Set Speed opto output becomes active (turns on). When the speed is greater than the Level 1 Output SET SPEED parameter, the Opto Output becomes active. This is useful when another machine must not start or stop until the motor exceeds a predetermined speed.																																		
	Analog Output #1 and #2	<p>Two Analog 0-5VDC linear outputs may be configured to represent any of 19 conditions as follows:</p> <table border="1" data-bbox="662 863 1563 1801"> <thead> <tr> <th data-bbox="662 863 812 890">Condition</th> <th data-bbox="836 863 974 890">Description</th> </tr> </thead> <tbody> <tr> <td data-bbox="662 905 812 932">ABS Speed -</td> <td data-bbox="836 905 1563 961">Represents the absolute motor speed where 0VDC = 0 RPM and +5VDC = MAX RPM.</td> </tr> <tr> <td data-bbox="662 968 812 995">ABS Torque -</td> <td data-bbox="836 968 1563 1100">Represents the absolute value of torque where +5VDC = Torque at CURRENT LIMIT. The absolute torque output is scaled by the torque constant. The torque constant or torque per armature amp drops as the field current drops. Thus, in field weakening the torque output remains accurate. Useful as a load meter output.</td> </tr> <tr> <td data-bbox="662 1106 812 1163">ABS Speed - Command</td> <td data-bbox="836 1106 1563 1163">Represents the absolute value of commanded speed where +5VDC = MAX RPM.</td> </tr> <tr> <td data-bbox="662 1169 812 1226">Field Current -</td> <td data-bbox="836 1169 1563 1226">5 VDC = max. supply amps (e.g. 5V = 15 amps for a 15 amp field power supply).</td> </tr> <tr> <td data-bbox="662 1232 812 1260">CMD Field CUR -</td> <td data-bbox="836 1232 1563 1260">5 VDC = max supply amps.</td> </tr> <tr> <td data-bbox="662 1266 812 1293">ARM Current -</td> <td data-bbox="836 1266 1563 1293">2.5 VDC = 0.0, +5 VDC = + current limit, 0 VDC = - current limit.</td> </tr> <tr> <td data-bbox="662 1299 812 1327">CMD ARM CUR -</td> <td data-bbox="836 1299 1563 1327">2.5 VDC = 0.0, +5 VDC = + current limit, 0 VDC = - current limit.</td> </tr> <tr> <td data-bbox="662 1333 812 1390">Firing Angle -</td> <td data-bbox="836 1333 1563 1390">Firing angle scaled +2.5 V = 0. 0V = max regen. +5V = MAX ADVANCE.</td> </tr> <tr> <td data-bbox="662 1396 812 1423">ARM Volts -</td> <td data-bbox="836 1396 1563 1423">Arm volts scaled 2.5V = 0, 0V = $\frac{1}{2}$</td> </tr> <tr> <td data-bbox="662 1430 812 1457">Field Volts -</td> <td data-bbox="836 1430 1563 1457">Field volts, 4 volts = RATED FIELD VOLTAGE.</td> </tr> <tr> <td data-bbox="662 1463 812 1491">Torque -</td> <td data-bbox="836 1463 1563 1520">Bipolar torque output. 2.5V centered, 5V = Max Positive Torque, 0V = Max negative torque.</td> </tr> <tr> <td data-bbox="662 1526 812 1554">Power -</td> <td data-bbox="836 1526 1563 1583">Bipolar power output. 2.5V = Zero Power, 0V = negative rated peak power, +5V = Positive rated peak power.</td> </tr> <tr> <td data-bbox="662 1589 812 1617">Velocity -</td> <td data-bbox="836 1589 1563 1646">Represents motor speed scaled to 0V = negative max RPM, +2.5V = Zero Speed, +5V = positive max RPM.</td> </tr> <tr> <td data-bbox="662 1652 812 1680">Overload -</td> <td data-bbox="836 1652 1563 1680">(Accumulated current)² x (time), Overload occurs at +5V. (I²t)</td> </tr> <tr> <td data-bbox="662 1686 812 1713">Position -</td> <td data-bbox="836 1686 1563 1743">Position within a single revolution. +5V = 1 complete revolution. The counter will reset to 0 every revolution.</td> </tr> <tr> <td data-bbox="662 1749 812 1776">Line Timer -</td> <td data-bbox="836 1749 1563 1776">Internally used square wave form, phase locked to L1-L2.</td> </tr> </tbody> </table>	Condition	Description	ABS Speed -	Represents the absolute motor speed where 0VDC = 0 RPM and +5VDC = MAX RPM.	ABS Torque -	Represents the absolute value of torque where +5VDC = Torque at CURRENT LIMIT. The absolute torque output is scaled by the torque constant. The torque constant or torque per armature amp drops as the field current drops. Thus, in field weakening the torque output remains accurate. Useful as a load meter output.	ABS Speed - Command	Represents the absolute value of commanded speed where +5VDC = MAX RPM.	Field Current -	5 VDC = max. supply amps (e.g. 5V = 15 amps for a 15 amp field power supply).	CMD Field CUR -	5 VDC = max supply amps.	ARM Current -	2.5 VDC = 0.0, +5 VDC = + current limit, 0 VDC = - current limit.	CMD ARM CUR -	2.5 VDC = 0.0, +5 VDC = + current limit, 0 VDC = - current limit.	Firing Angle -	Firing angle scaled +2.5 V = 0. 0V = max regen. +5V = MAX ADVANCE.	ARM Volts -	Arm volts scaled 2.5V = 0, 0V = $\frac{1}{2}$	Field Volts -	Field volts, 4 volts = RATED FIELD VOLTAGE.	Torque -	Bipolar torque output. 2.5V centered, 5V = Max Positive Torque, 0V = Max negative torque.	Power -	Bipolar power output. 2.5V = Zero Power, 0V = negative rated peak power, +5V = Positive rated peak power.	Velocity -	Represents motor speed scaled to 0V = negative max RPM, +2.5V = Zero Speed, +5V = positive max RPM.	Overload -	(Accumulated current) ² x (time), Overload occurs at +5V. (I ² t)	Position -	Position within a single revolution. +5V = 1 complete revolution. The counter will reset to 0 every revolution.	Line Timer -	Internally used square wave form, phase locked to L1-L2.
	Condition	Description																																		
ABS Speed -	Represents the absolute motor speed where 0VDC = 0 RPM and +5VDC = MAX RPM.																																			
ABS Torque -	Represents the absolute value of torque where +5VDC = Torque at CURRENT LIMIT. The absolute torque output is scaled by the torque constant. The torque constant or torque per armature amp drops as the field current drops. Thus, in field weakening the torque output remains accurate. Useful as a load meter output.																																			
ABS Speed - Command	Represents the absolute value of commanded speed where +5VDC = MAX RPM.																																			
Field Current -	5 VDC = max. supply amps (e.g. 5V = 15 amps for a 15 amp field power supply).																																			
CMD Field CUR -	5 VDC = max supply amps.																																			
ARM Current -	2.5 VDC = 0.0, +5 VDC = + current limit, 0 VDC = - current limit.																																			
CMD ARM CUR -	2.5 VDC = 0.0, +5 VDC = + current limit, 0 VDC = - current limit.																																			
Firing Angle -	Firing angle scaled +2.5 V = 0. 0V = max regen. +5V = MAX ADVANCE.																																			
ARM Volts -	Arm volts scaled 2.5V = 0, 0V = $\frac{1}{2}$																																			
Field Volts -	Field volts, 4 volts = RATED FIELD VOLTAGE.																																			
Torque -	Bipolar torque output. 2.5V centered, 5V = Max Positive Torque, 0V = Max negative torque.																																			
Power -	Bipolar power output. 2.5V = Zero Power, 0V = negative rated peak power, +5V = Positive rated peak power.																																			
Velocity -	Represents motor speed scaled to 0V = negative max RPM, +2.5V = Zero Speed, +5V = positive max RPM.																																			
Overload -	(Accumulated current) ² x (time), Overload occurs at +5V. (I ² t)																																			
Position -	Position within a single revolution. +5V = 1 complete revolution. The counter will reset to 0 every revolution.																																			
Line Timer -	Internally used square wave form, phase locked to L1-L2.																																			
Analog Scale #1 & #2	Scale factor for the Analog Output voltage. Useful to set the zero value or full scale range for external meters.																																			
Position Band	Sets the acceptable range in digital counts (pulses) at which the AT Position Opto becomes active (turns on).																																			

Table 3-2 Level 1 Parameter Block Definitions - Continued

Block Title	Parameter	Description
DC Control	CTRL BASE Volts	This sets the armature voltage where the control begins to go into "field weakening" to achieve higher speeds from the motor (not available with armature feedback). Chooses lowest voltage between ARMATURE VOLTAGE, 130% of Line Voltage, or the manual setting for CTRL BASE VOLTS. Adjustable range is 0-1000V.
	Feedback Filter	Sets the number of scans by the control's microprocessor to filter the encoder input signal. It is automatically set to suit the encoder resolution during the Auto Tuning function. A larger value provides a more filtered signal but at the cost of reduced bandwidth. A smaller value provides smoother low speed operation.
	Feedback DIR	Sets the encoder's electrical direction of rotation to match that of the motor.
	ARM PROP Gain	Sets the current loop proportional gain.
	ARM INT Gain	Sets the current loop integral gain.
	Speed PROP Gain	Sets the speed (velocity) loop proportional gain.
	Speed INT Gain	Sets the speed (velocity) loop integral gain.
	Speed DIFF Gain	Sets the speed (velocity) loop differential gain.
	Position Gain	Sets the position loop proportional gain.
	IR COMP Gain (See Note 1)	Sets gain for armature resistance compensation. Used for armature feedback only. When using armature feedback, begin with a setting of 50 and adjust as needed for removal of speed error (No-Load/Load), smoothness and stability.
	TACH Trim	Scales tachometer voltage to compensate for individual tach voltage scale factor.
	Null Force Gain	Adjusts small signal current loop response relative to changes in firing angle. Helps current loop response to be nominal over the entire current range of the control, particularly at light loads.
TACH Offset	Adjusts a deadband at zero speed when using DC Tachometer feedback. Helps prevent creeping at zero speed.	

Note 1: For Armature Feedback, the IR COMP Gain adjustment compensates for the armature voltage drop. Excessive IR COMP Gain may cause motor speed to become erratic. Shunt wound motors that have a rising speed characteristic (where speed increases with load) may not be suitable for armature feedback. Instead, Tachometer or Encoder feedback should be used for these shunt wound applications. Stabilized shunt wound motors have a very flat speed/torque characteristic and work well with armature feedback but may not work correctly in reversing applications.

To set IR COMP Gain:

1. Run motor at base speed with no load. Measure RPM with hand held tachometer and record the RPM.
(Do not rely on the RPM display of the control as it may not be accurate with armature feedback.)
2. Run motor at base speed with full load. Measure RPM with hand held tachometer and record the RPM.
3. Adjust IR COMP Gain 5 units.
4. Repeat steps 1 to 3 until no load speed (step 1) and full load speed (step 2) are matched.

Table 3-2 Level 1 Parameter Block Definitions - Continued

Block Title	Parameter	Description
Field Control	Field PWR Supply	This is used to select the type of field power supply used with the control. The standard power supply (for controls to 300HP) can supply up to 15 amps for shunt wound motors. If using permanent magnet motors, the field power supply may be disabled by selecting NONE. If the shunt wound motor requires more than 15 amps for its field, an optional 40 amp field power supply may be added.
	Field ECON Level	Sets the field voltage applied to the motor during stand-still while the control is disabled. This is used to keep the fields warm to ensure the motor can run to its base speed. Field economy is also often used instead of a space heater. Excessive voltage may cause the field to overheat resulting in premature motor failure. Any value less than 25% (or 100 mA) causes the field economy circuit to be off when disabled and automatically set to 0%.
	Forcing Level	This setting is often used in the hoist mode to over saturate the fields causing a soft start or stop. Only available in Series 20H Line Regen controls and used in BIPOLAR HOIST and 7 SPEED HOIST modes.
	Field Set Speed	This sets the speed at which the field voltage is switched from the Forcing Level to the standard field run voltage. Only available in Series 20H Line Regen controls.
	Field Step Limit	This sets the ramp rate time when changing from field levels (field force voltage to standard run voltage). Only available in Series 20H Line Regen controls.
	Field REG Gain	This sets the proportional gain in the field current control.
	Field Integral	Selects the gain type for the field regulator. Setting Field Integral to ON selects PI gains. OFF selects proportional only. In most cases, the ON setting will improve the accuracy of the field control current settings.
	LEVEL 2 BLOCK	

Figure 3-3 Relationship of Field Control Parameters

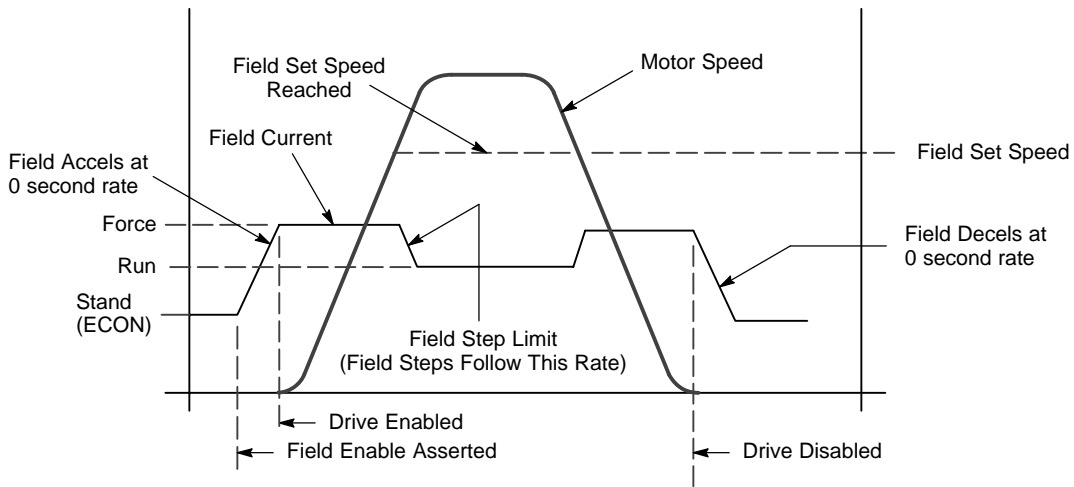

Field Forcing, Field Set Speed and Field Step Limit parameters are not active with Series 20H controls. These parameters are only active for Series 20H Line Regen controls when operated in the Bipolar Hoist or 7 Speed Hoist modes.

Table 3-3 Level 2 Parameter Block Definitions

Block Title	Parameter	Description
OUTPUT LIMITS	Operating Zone	Sets the operating zone to One Way (Non Line Regenerative) or REGEN.
	MIN Output Speed	Sets the minimum motor speed in RPM. During operation, the motor speed will not be allowed to go below this value except for motor starts from 0 RPM.
	MAX Output Speed	Sets the maximum motor speed in RPM.
	PK Current Limit	The maximum output peak current to the motor. Values above 100% of the rated current are available depending upon the operating zone selected.
	CUR Rate Limit	Limits the motor inrush current to protect the motor commutator.
* CUSTOM UNITS	Decimal Places	The number of decimal places of the Output Rate display on the Keypad display. This value will be automatically reduced for large values. The output rate display is only available if the Value At Speed parameter value is non zero.
	Value At Speed	Sets the desired output rate per RPM of motor speed. Two numbers are displayed on the keypad display (separated by a slash "/"). The first number (left most) is the value you want the keypad to display at a specific motor speed. The second number (right most) is the motor RPM corresponding to the units in the first number. A decimal may be inserted into the numbers by placing the flashing cursor over the up/down arrow.
	Units of Measure	Allows user specified units of measure to be displayed on the Output Rate display. Use the shift and arrow keys to scroll to the first and successive characters. If the character you want is not displayed, move the flashing cursor over the special up/down character arrow on the left side of the display. Use the up/down arrows and the shift key to scroll through all 9 character sets. Use the ENTER key to save your selection.
PROTECTION	Overload	Sets the protection mode to Fault (trip off during overload condition) or to Foldback (automatically reduce the output current below the continuous output level) during an overload. Foldback is the choice if continuous operation is desired. Fault will require the control be "Reset" after an overload.
	External Trip	OFF - External Trip is Disabled. ON - External Trip is enabled. If a normally closed contact at J1-16 is opened, an External Trip fault will occur and cause the drive to shut down.
	Following Error	This parameter determines if the control is to monitor the amount of following error that occurs in an application. Following Error is the programmable tolerance for the AT Speed Opto output as defined by the Level 1 Output block, AT Speed Band parameter. Operation outside the speed range will cause a fault and the drive will shut down.
	Torque Proving	When this parameter is set to ON the control tests for armature circuit continuity for a 20ms period. It indicates a torque proving fault if sufficient current is not sensed. This feature is useful in many applications to ensure torque is being applied. In a hoist, for example, torque proving could be used to make sure torque exists before a brake is released. "Drive On" output, if programmed, will not occur if torque proving fails. Available settings are On and OFF. Factory setting is OFF.

* Custom Units is present in software versions 1.23 and previous.

Table 3-3 Level 2 Parameter Block Definitions Continued

Block Title	Parameter	Description
MISCELLANEOUS	Restart Auto/Man	Manual - If a fault or power loss occurs, the control must be manually reset to resume operation. Automatic - If a fault or power loss occurs, the control will automatically reset to resume operation.
	Restart Fault/Hr	The maximum number of automatic restart attempts before requiring a manual restart. After one hour without reaching the maximum number of faults or if power is turned off and on again, the fault count is reset to zero.
	Restart Delay	The amount of time allowed after a fault condition for an automatic restart to occur. Useful to allow sufficient time to clear a fault before restart is attempted.
	Factory Settings	Restores factory settings for all parameter values. Select YES and press "ENTER" key to restore factory parameter values. The keypad Display will show "Operation Done" then return to "NO" when completed. Note: When factory settings are reset, the Motor Rated Amps value is reset to 999.9 amps. This Level 2 Motor Data block parameter value must be changed to the correct value (located on the motor rating plate) before attempting to start the drive and auto tune.
	Homing Speed	In Bipolar and Serial modes, this parameter sets the speed that the motor shaft will rotate to a "Home" position when the orient input switch is closed (J1-11).
	Homing Offset	In Bipolar and Serial modes, this parameter sets the number of digital encoder counts past home at which the motor stop command is issued. Quadrature encoder pulses are 4 times the number of encoder lines per revolution. The recommended minimum number is 100 encoder counts to allow for deceleration distance to allow the motor to stop smoothly. Note: Homing direction is always forward.

Table 3-3 Level 2 Parameter Block Definitions Continued

Block Title	Parameter	Description
SECURITY CONTROL	Security State	<p>Off - No security Access Code required to change parameter values. Local - Requires security Access Code to be entered before changes can be made using the Keypad. Serial - Requires security Access Code to be entered before changes can be made using the Serial Link. Total - Requires security Access Code to be entered before changes can be made using the Keypad or serial link.</p> <p>Note: If security is set to Local, Serial or Total you can press PROG and scroll through the parameter values that are programmed but you are not allowed to change them unless you enter the correct access code.</p>
	Access Timeout	The time in seconds the security access remains enabled after leaving the programming mode. If you exit and go back into the program Mode within this time limit, the security Access Code does not have to be re-entered. This timer starts when leaving the Program Mode (by pressing DISP).
	Access Code	<p>A 4 digit number code. Only persons that know the code can change secured Level 1 and Level 2 parameter values.</p> <p>Note: Please record your access code and store it in a safe place. If you cannot gain entry into parameter values to change a protected parameter, please contact Baldor. Be prepared to give the 5 digit code shown on the lower right side of the Keypad Display at the Security Control Access Code parameter prompt.</p>
MOTOR DATA	Armature Voltage	The rated Armature voltage of the motor (listed on the motor nameplate).
	ARM Rated Amps	The rated armature current of the motor (listed on the motor nameplate). If the motor current exceeds this value for a period of time, an Overload fault will occur.
	Motor Rated SPD	The rated speed of the motor (listed on the motor nameplate). In the case of wound field motor nameplates, speed may be indicated as Base Speed/Max Field Weakened Speed. The base speed is entered in the MOTOR RATED SPD parameter. The Max Field Weakened Speed may be entered in the MAXIMUM OUTPUT SPEED parameter located in the Output Limits block, if operation faster than base speed is desired.
	Motor Field	This indicates the type of field in the motor. Available settings are Shunt and Permanent Magnet.
	Motor Field Volts	The rated field volts of the motor (listed on the motor nameplate based on the connections you have made). Many motors have a dual voltage field that may be connected in series or parallel. Maximum field voltage = (AC Line Volts) x 0.85.
	Motor Field Amps	The rated field amps of the motor for base speed operation and based on the connections you have made. Many motors have a dual voltage field. This is stated on the motor nameplate or shown in the motor connection diagram. The standard field supply for controls up to 300HP is 15 Amps. An optional 40 Amp field supply is available for dual voltage field motors and for controls that are 400HP and larger. If the field current drops to less than 0.15A, a Field Loss Fault will be displayed by the control.
	Feedback Type	This designates the type of feedback used by the control. The control's standard feedback options are ENCODER and ARMATURE. Specify ARMATURE if the control is operated open loop and start with the IR Comp Gain set to 50. DC tachometer and resolver feedback are available with the appropriate optional expansion boards. Feedback device must be coupled to the motor shaft or at a 1:1 ratio.
	Encoder Counts	The number of counts (pulses) per revolution, if an encoder is feedback type.
	Resolver Speed	The speed of the resolver, if a resolver is used for feedback type. The parameter is only active when the optional Resolver to Digital expansion board is installed.
	Tachometer Volts	The DC volts per 1000 RPM output of the tachometer (V/KRPM). The parameter is only active when the optional tachometer feedback expansion board is installed.
PK Power Limit	This setting is often used as a commutation limiter in permanent magnet servo motors to set the peak current for commutation limits. This parameter is only active when PERM MAGNET is selected for motor field type.	

Table 3-3 Level 2 Parameter Block Definitions Continued

Block Title	Parameter	Description
PROCESS CONTROL	Process Feedback	Sets the type of signal used for the process feedback signal.
	Process Inverse	Causes the process feedback signal to be inverted. Used with reverse acting processes that use a unipolar signal such as 4-20mA. If "ON", 20mA will decrease motor speed and 4mA will increase motor speed.
	Setpoint Source	Sets the source input signal type to which the process feedback will be compared. If "Setpoint CMD" is selected, the fixed value of the set point is entered in the Setpoint Command parameter value.
	Setpoint Command	Sets the value of the setpoint the control will try to maintain by adjusting motor speed. This is only used when the Setpoint Source is a fixed value "Setpoint CMD" under Setpoint Source.
	Set PT ADJ Limit	Sets the maximum speed correction value to be applied to the motor (in response to the maximum feedback setpoint error). For example, if the max motor speed is 1750 RPM, the setpoint feedback error is 100% and the setpoint adjustment limit is 10%, the maximum speed the motor will run in response to the setpoint feedback error is ± 175 RPM. If at the process setpoint, the motor speed is 1500 RPM, the maximum speed adj limits is then 1325 to 1675 RPM.
	Process ERR TOL	Sets the width of the comparison band (% of setpoint) with which the process input is compared. The result is that if the process input is within the comparison band the corresponding Opto Output will become active.
	Process PROP Gain	Sets the PID loop proportional gain. This determines how much adjustment to motor speed (within the Set PT ADJ Limit) is made to move the analog input to the setpoint.
	Process INT Gain	Sets the PID loop Integral gain. This determines how quickly the motor speed is adjusted to correct long term error.
	Process DIFF Gain	Sets the PID loop differential gain. This determines how much adjustment to motor speed (within the Set PT ADJ Limit) is made for transient error.
	Follow I:O Ratio	Sets the ratio of the Master to the Follower in Master/Follower configurations. Requires the Master Pulse Reference/ Isolated Pulse Follower expansion board. For example, the master encoder you want to follow is a 1024 count encoder. The follower motor you wish to control also has a 1024 count encoder on it. If you wish the follower to run twice the speed of the master, a 1:2 ratio is entered. Fractional ratios such as 0.5:1 are entered as 1:2. Ratio limits are (65,535:1) to (1:20). Note: The Master Encoder parameter must be defined if a value is entered in the Follow I:O Ratio parameter. Note: When using Serial Communications to operate the control, this value is the MASTER portion of the ratio. The FOLLOWER portion of the ratio is set in the Follow I:O Out parameter.
	Follow I:O Out	This parameter is used only when Serial Communications is used to operate the control. A Master Pulse Reference/ Isolated Pulse Follower expansion board is required. This parameter represents the FOLLOWER portion of the ratio. The MASTER portion of the ratio is set in the Follow I:O Ratio parameter.
	Master Encoder	Only used if an optional Master Pulse Reference/Isolated Pulse Follower expansion board is installed. Defines the number of pulses per revolution of the master encoder. Only used for follower drives.

Table 3-3 Level 2 Parameter Block Definitions Continued

Block Title	Parameter	Description
AUTO TUNING	CALC Presets CMD Offset Trim CUR Loop COMP Feedback Tests SPD CNTRLR CALC	<p>The Auto Tune procedure is used to automatically measure and calculate certain parameter values after motor data has been entered. Run CALC PRESETS, CMD OFFSET TRIM, CUR LOOP COMP and FEEDBACK TESTS with the motor uncoupled from the load. SPD CNTRLR CALC should be run with the load coupled to the motor (if possible). Ensure that both the load and motor are free to rotate freely.</p> <p>This procedure loads preset values into memory that are required to perform Auto Tune. Always run CALC Presets as the first step of Auto Tune.</p> <p>This procedure trims out voltage offsets for the differential analog input at J1-4 and J1-5.</p> <p>Measures current response to pulses of 30° firing angle.</p> <p>This procedure checks the values for ENCODER COUNTS and ENCODER DIR. This is accomplished by accelerating the motor open loop, detecting the phasing of encoder feedback and counting the number of encoder pulses per revolution of the motor. This works for resolvers and determines direction in tachometer systems. Not required for ARMATURE FEEDBACK.</p> <p>This procedure accelerates the motor to measure the current to acceleration ratio. It also adjusts Speed Control Integral Gain and Speed Control Proportional Gain. Because auto-tune is usually done with no load, it will generally set the Speed Control Integral Gain too high for low inertia motors and loads if Current Limit is set too low. If the control is too responsive when loaded, set the current limit to the proper value and rerun this procedure.</p>
LEVEL 1 BLOCK		ENTERS LEVEL 1 MENU

Section 4 Troubleshooting

The Baldor Series 20H Control requires very little maintenance and should provide years of trouble free operation when installed and applied correctly. Occasional visual inspection should be considered to ensure tight wiring connections and to avoid the build up of any dust, dirt, or foreign debris which can reduce heat dissipation.

Before attempting to service this equipment, all input power must be removed from the control to avoid the possibility of electrical shock. The servicing of this equipment should be handled by a qualified electrical service technician experienced in the area of high power electronics.





It is important to familiarize yourself with the following information before attempting any troubleshooting or service of the control. Most troubleshooting can be performed using only a digital voltmeter having an input impedance exceeding 1 meg Ohm. In some cases, an oscilloscope with 5 MHz minimum bandwidth may be useful. Before consulting the factory, check that all power and control wiring is correct and installed per the recommendations given in this manual.

No Keypad Display - Display Contrast Adjustment



If there is no visible display, use the following procedure to adjust the contrast of the display.

Action	Description	Display	Comments
Apply Power	No visible display.	BLANK	Display mode.
Press DISP key	Ensures control in Display mode.	BLANK	
Press SHIFT key 2 times	Allows display contrast adjustment.	ADJUST CONTRAST ⬆ (ENTER) TO SAVE	
Press ▲ or ▼ key	Adjusts display contrast (intensity).	ADJUST CONTRAST ⬆ (ENTER) TO SAVE	
Press ENTER key	Saves display contrast adjustment level and exits to display mode.	STOP MOTOR SPEED LOCAL 0 RPM	

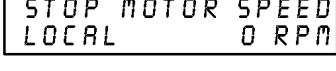
How to Access the Fault Log When a fault condition occurs, motor operation stops and a fault code is displayed on the Keypad display. The control keeps a log of up to the last 31 faults. If more than 31 faults have occurred the oldest fault will be deleted from the fault log to make room for the newest fault. To access the fault log use the following procedure:

Action	Description	Display	Comments
Apply Power			Logo display for 5 seconds.
	Display mode showing output frequency		Display mode.
Press DISP key 5 times	Use DISP key to scroll to the Fault Log entry point.		
Press ENTER key	Display first fault type and time fault occurred.		Typical display.
Press ▲ key	Scroll through fault messages.		If no messages, the fault log exit choice is displayed.
Press ENTER key	Return to display mode.		Display mode stop key LED is on.

How to Clear the Fault Log Use the following procedure to clear the fault log.

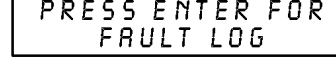
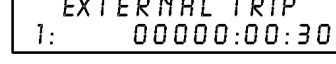
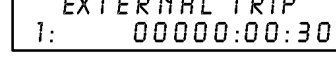
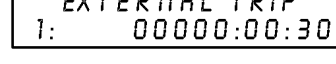
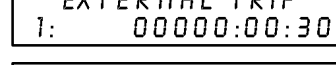
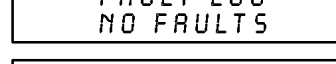
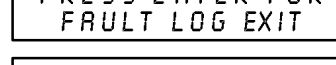
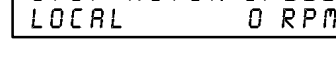
Action	Description	Display	Comments
Apply Power			Logo display for 5 seconds.
	Display mode showing output frequency.		Display mode.
Press DISP key	Press DISP to scroll to the Fault Log entry point.		
Press ENTER key	Displays most recent message.		
Press SHIFT key			
Press RESET key			
Press SHIFT key			
Press ENTER key	Fault log is cleared.		No faults in fault log.
Press ▲ or ▼ key	Scroll Fault Log Exit.		
Press ENTER key	Return to display mode.		

How to Access Diagnostic Information

Action	Description	Display	Comments
Apply Power		<pre>BALDOR MOTORS & DRIVES</pre>	Logo display for 5 seconds.
	Display mode showing motor speed.	<pre>STOP MOTOR SPEED LOCAL 0 RPM</pre>	No faults present. Local keypad mode. If in remote/serial mode, press local for this display.
Press DISP key 5 times	Scroll to Diagnostic Information screen	<pre>PRESS ENTER FOR DIAGNOSTIC INFO</pre>	Diagnostic Access screen.
Press ENTER key	Access diagnostic information.	<pre>STOP SPEED REF LOCAL 0 RPM</pre>	First Diagnostic Information screen.
Press DISP key	Display mode showing control temperature.	<pre>STOP CONTROL TEMP LOCAL 0.0° C</pre>	
Press DISP key	Display mode showing % overload current remaining.	<pre>STOP OVRLD LEFT LOCAL 100.00%</pre>	
Press DISP key	Display mode showing opto inputs & outputs states. 0=Open, 1=Closed	<pre>DIGITAL I/O 00000000 0000</pre>	Opto Inputs states (Left); Opto Outputs states (Right).
Press DISP key	Display mode showing actual drive running time.	<pre>TIME FROM PUR UP 0000000.01.43</pre>	HR.MIN.SEC format.
Press DISP key	Display mode showing operating mode, voltage and control type.	<pre>100HP REGEN 460V DIGITAL DC</pre>	
Press DISP key	Display mode showing continuous amps; PK amps rating; amps/volt scale of feedback, power base ID.	<pre>X.XA APK X.XX A/V ID:XXX</pre>	ID is displayed as a hexadecimal value.
Press DISP key	Display mode showing which Group1 or 2 expansion boards are installed.	<pre>G1 DC TACHOMETER G2 NOT INSTALLED</pre>	
Press DISP key	Display mode showing motor shaft revolutions from the REV home set point.	<pre>POSITION COUNTER + 000:00000 REV</pre>	
Press DISP key	Display mode showing firmware version and revision installed in the control.	<pre>SOFTWARE VERSION XXX-X.XX</pre>	
Press DISP key	Displays exit choice.	<pre>PRESS ENTER FOR DIAGNOSTIC EXIT</pre>	Press ENTER to exit diagnostic information.

Table 4-4 Troubleshooting

INDICATION	POSSIBLE CAUSE	CORRECTIVE ACTION
ARM V FDBK	The control has detected an excessive amount of armature feedback voltage on the armature during power-up.	The permanent magnet motor may be rotating on power-up.
	Excessive noise on cables.	Separate armature leads from any other power.
	Defective base ID board.	Call Baldor if problem remains.
AUTO TUNE ENCODER TEST	Encoder miswired.	Correct wiring problems.
	Encoder coupling slipping, broken or misaligned.	Correct encoder to motor coupling.
	Excessive noise on encoder lines.	Check the position counter in the Diagnostic Information for jittering which will confirm an encoder problem. Use recommended encoder cable. Check encoder connections including shields. Separate encoder leads from power wiring. Cross encoder cables and power leads at 90°. Electrically isolate encoder from motor. Install optional Isolated Encoder Feedback expansion board.
CHK TACH JUMPERS	Incorrect DC tach expansion board jumper settings.	User entered TACH VOLTS or MAX SPEED has changed the tach board jumper setting. Check tach board info in the DIAGNOSTICS DISPLAY, correct jumper settings. press RESET.
CURR SENSE	Excessive armature current feedback.	Suspect ±15V supply fault, wiring between base ID and feedback boards, defective feedback board or TACH board scaling.
ENCODER LOSS	Encoder power supply failure.	Check 5VDC at J1-29 and J1-30. Also check at encoder end pins D and F.
	Encoder coupling slipping, broken or misaligned	Correct or replace encoder to motor coupling.
	Excessive noise on encoder lines.	Check the position counter in the Diagnostic Information for jittering which will confirm an encoder problem. Check encoder connections. Separate encoder leads from power wiring. Cross encoder cables and power leads at 90°. Electrically isolate encoder from motor. Install optional Isolated Encoder Feedback expansion board.
TACH LOSS	Tach coupling slipped or broken.	Check tach to motor coupling.
	Excessive noise on tach lines.	Check tach connections. Separate tach leads from power wiring. Cross power leads at 90°. Use shielded tach leads.
	Wrong jumper settings on DC TACH expansion board.	Check jumper selection based on tach output and MAX SPEED of motor. Reset at needed.
	DC Contactor may be open.	Check contactor.
RESOLVER LOSS	Resolver coupling slipped or broken.	Check resolver to motor coupling.
	Incorrect connections to Resolver Feedback expansion board.	Check Resolver Feedback expansion board manual for correct wiring and parameters.
	Excessive noise on resolver lines.	Check resolver connections. Separate resolver leads from power wiring. Cross power leads at 90°. Use shielded resolver leads.

Table 4-4 Troubleshooting Continued

INDICATION	POSSIBLE CAUSE	CORRECTIVE ACTION
EXTERNAL TRIP	Motor ventilation insufficient.	Clean motor air intake and exhaust. Check external blower for operation and proper direction of rotation. Verify motor's internal fan is coupled securely.
	Motor draws excessive current.	Check motor for overloading. Verify proper sizing of control and motor.
	No thermostat connected.	Verify thermostat has normally closed contacts. Connect thermostat. Verify connection of all external trip circuits used with thermostat. Disable thermostat input at J1-16 (External Trip Input).
	Poor thermostat connections.	Check thermostat connections.
	External trip parameter incorrect.	Verify connection of external trip circuit at J1-16. Set external trip parameter to "OFF" if no connection made at J1-16.
FOLLOWING ERR	Speed proportional gain set too low.	Following error tolerance band set too narrow. Increase Speed PROP Gain parameter value.
	Current limit set too low.	Increase Current Limit parameter value.
	ACCEL/DECEL time too short.	Increase ACCEL/DECEL parameter time
	Excessive load.	Verify proper sizing of control and motor.
	Following Error parameter set to ON by mistake.	Set Level 2 Protection block, Following Error parameter to OFF.
	Following Error window too small.	Increase Level 1 Output block, AT Speed Band parameter RPM.
INT OVER-TEMP	Motor Overloaded.	Correct motor loading. Verify proper sizing of control and motor.
	Ambient temperature too high.	Relocate control to cooler operating area. Add cooling fans or air conditioner to control cabinet.
INVALID BASE ID	Control does not recognize HP and Voltage configuration.	Press "RESET" key on keypad. If fault remains, call Baldor.
LOGIC SUPPLY	Power supply malfunctioned.	Replace logic power supply.
LOST USER DATA	Battery backed memory failure.	Parameter data was erased. Disconnect power to control and apply power (cycle power). Enter all parameters. Cycle power. If problem persists, contact Baldor.
MEMORY ERROR	EEPROM memory fault occurred.	Press "RESET" key on keypad. If fault remains, call Baldor.
μP RESET	Excessive noise on Opto Output lines.	Check Opto Outputs and add snubbers if needed. If fault remains, call Baldor.
	A processor error occurred or the 5VDC power was lost.	Press "RESET" key on keypad. If fault remains, call Baldor.
LOW LINE	The AC input line is below the rated input voltage limits.	Check AC input power. Correct if below minimum requirements.
HIGH LINE	The AC input line is above the rated input voltage limits.	Check AC input power. Correct if above minimum requirements.
FIELD LOSS	Using permanent magnet DC motor.	Set control parameters for PERMANENT MAGNET in MOTOR DATA block, FIELD TYPE.
	Blown fuse in field power supply.	Check fuses and replace as needed.
	Improperly wired motor field.	Check motor field connections for correctness and continuity.

Table 4-4 Troubleshooting Continued

INDICATION	POSSIBLE CAUSE	CORRECTIVE ACTION
MOTOR HAS WRONG RESPONSE TO SPEED COMMAND	Analog input common mode voltage may be excessive.	Connect control input source common to control common to minimize common mode voltage. Maximum common mode voltage at terminals J1-4 and J1-5 is ± 15 VDC referenced to chassis common.
	Speed is 4 times the commanded speed, with encoder feedback	Check if \bar{A} and \bar{B} are reversed.
MOTOR WILL NOT START	Not enough starting torque.	Increase Current Limit setting.
	Motor overloaded.	Check for proper motor loading. Check couplings for binding. Verify proper sizing of control and motor.
	Motor field parameter incorrect.	Change to Shunt or PERM Magnet as required.
	Control not in local mode of operation.	Place control in local mode.
	MAX output speed parameter set to zero (0).	Change Level 2 Output Limits, MAX Output Speed parameter.
	Incorrect Command Select parameter.	Change Command Select parameter to match wiring at J1.
	Incorrect speed command.	Verify control is receiving proper command signal at J1.
MOTOR WILL NOT REACH MAXIMUM SPEED	Max Output Speed set too low.	Adjust MAX Output Speed parameter value.
	Motor overloaded.	Check for mechanical overload. If unloaded motor shaft does not rotate freely, check motor bearings.
	Improper speed command.	Verify control is set to proper operating mode to receive speed command. Verify control is receiving proper command signal at input terminals. Check velocity loop gains.
	Motor Field Volts or Field Amps parameters are not correct.	Change Level 2 Motor Data, Field Volts or Field Amps parameter(s).
	Speed potentiometer failure.	Replace potentiometer.
MOTOR WILL NOT STOP ROTATION	MIN Output Speed parameter set too high.	Adjust MIN Output Speed parameter value.
	Improper speed command.	Verify control is receiving proper command signal at input terminals. Verify control is set to receive speed command.
	Speed potentiometer failure.	Replace potentiometer.
	Using Armature feedback and commanding 0 speed.	Motor stops when STOP key is pressed or control is disabled. Add TACH or Encoder feedback to improve zero speed performance.
MOTOR WILL NOT REVERSE	Incorrect control parameter.	Change Level 2 Output Limits block, Operating Zone parameter to REGEN.

Table 4-4 Troubleshooting Continued

INDICATION	POSSIBLE CAUSE	CORRECTIVE ACTION
NO DISPLAY	Lack of input voltage.	Check input power for proper voltage. Verify fuses are good (or breaker is not tripped).
	Loose connections.	Check input power termination. Verify connection of operator keypad.
	Adjust display contrast.	See Adjust Display Contrast in Section 2 of this manual.
	Encoder +VDC and common wires may be reversed.	Check encoder connections and correct any mistakes.
NEW BASE ID	Software parameters are not initialized on newly installed control board.	Press "RESET" key on keypad to clear the fault condition. Cycle power (turn power OFF then ON). Reset parameter values to factory settings. Access diagnostics and compare power base ID number to list in Table 4-5 to ensure a match. Re-enter the Parameter Block Values you recorded in the User Settings at the end of this manual. Autotune the control.
NO EXB INSTALLED	Incorrect operating mode programmed.	Change Operating Mode in the Level 1 Input block to one that does not require the expansion board.
	Need expansion board.	Install the correct expansion board for selected operating mode.
	Defective EXB.	Check connections of board to control or other group board. Check expansion board manual for correct connections. Call Baldor if problem remains.
OVERCURRENT	Current Limit parameter set to fast for motor commutation.	Increase PK Current Limit parameter in the Level 2 Output Limits block, not to exceed drive rating.
	ACCEL/DECEL time too short.	Increase ACCEL/DEC parameters in the Level 1 ACCEL/DECEL Rate block.
	Electrical noise from external DC coils.	Install reverse biased diodes across all external DC relay coils as shown in the Opto Output circuit examples of this manual. See Electrical Noise Considerations in Section 4 of this manual.
	Electrical noise from external AC coils.	Install RC snubbers on all external AC coils. See Electrical Noise Considerations in Section 4 of this manual.
	Excessive load.	Reduce the motor load. Verify proper sizing of control and motor.
	Current Rate Limit parameter set too fast for motor commutation.	Increase the Level 2 Output Limits block, CUR Rate Limit parameter time value.
OVERLOAD	Excessive Current.	Check PK Current Limit parameter in the Level 2 Output Limits block. Change Overload parameter In the Level 2 Protection block from Trip to Foldback. Check motor for overloading. Increase ACCEL/DECEL times. Reduce motor load. Verify proper sizing of control and motor.
OVER SPEED	Motor exceeded 110% of MAX Speed parameter value.	Check the Level 2 Output Limits block, Max Output Speed parameter. Increase the Level 1 DC Control block, Speed PROP Gain parameter.
TORQUE PROVE	Measured current to motor was insufficient.	Check continuity from control to motor windings and verify motor connections and brushes. This check is only performed when motor is started and when control is first enabled.
UNKNOWN	Fault occurred but cleared before its source could be identified.	Check AC line for high frequency noise. Check input switch connections and switching noise. Verify ground connections at Control and Motor.
USER FAULT TEXT	Fault detected by custom software.	Refer to custom software fault list.

Table 4-5 Power Base ID - Series 20H

130VAC Control Catalog Numbers	Power Base ID	230VAC Control Catalog Numbers	Power Base ID	460VAC Control Catalog Numbers	Power Base ID
				BC20H410-CL	13C
BC20H103-CL	F1	BC20H205-CL	0F2	BC20H420-CL	144
BC20H107-CL	F9	BC20H210-CL	0FA	BC20H430-CL	14C
BC20H110-CL	101	BC20H215-CL	102	BC20H440-CL	154
BC20H115-CL	109	BC20H220-CL	10A	BC20H450-CL	15C
BC20H120-CL	111	BC20H225-CL	112	BC20H475-CL	164
BC20H125-CL	119	BC20H240-CL	11A	BC20H4100-CL	16C
BC20H135-CL	121	BC20H250-CL	112	BC20H4125-CL	174
BC20H140-CL	129	BC20H260-CL	12A	BC20H4150-CL	17C
BC20H150-CL	131	BC20H275-CL	132	BC20H4200-CL	1A4
		BC20H2125-CL	182	BC20H4250-CL	184
				BC20H4300-CL	18C
				BC20H4400-EL	1AC
				BC20H4500-EL	194
				BC20H4600-EL	19C

Note: The Power Base ID number of a control is displayed in a Diagnostic Information screen as a hexadecimal value.

Control Circuit Board Test Points

Figure 4-1 Test Point Description

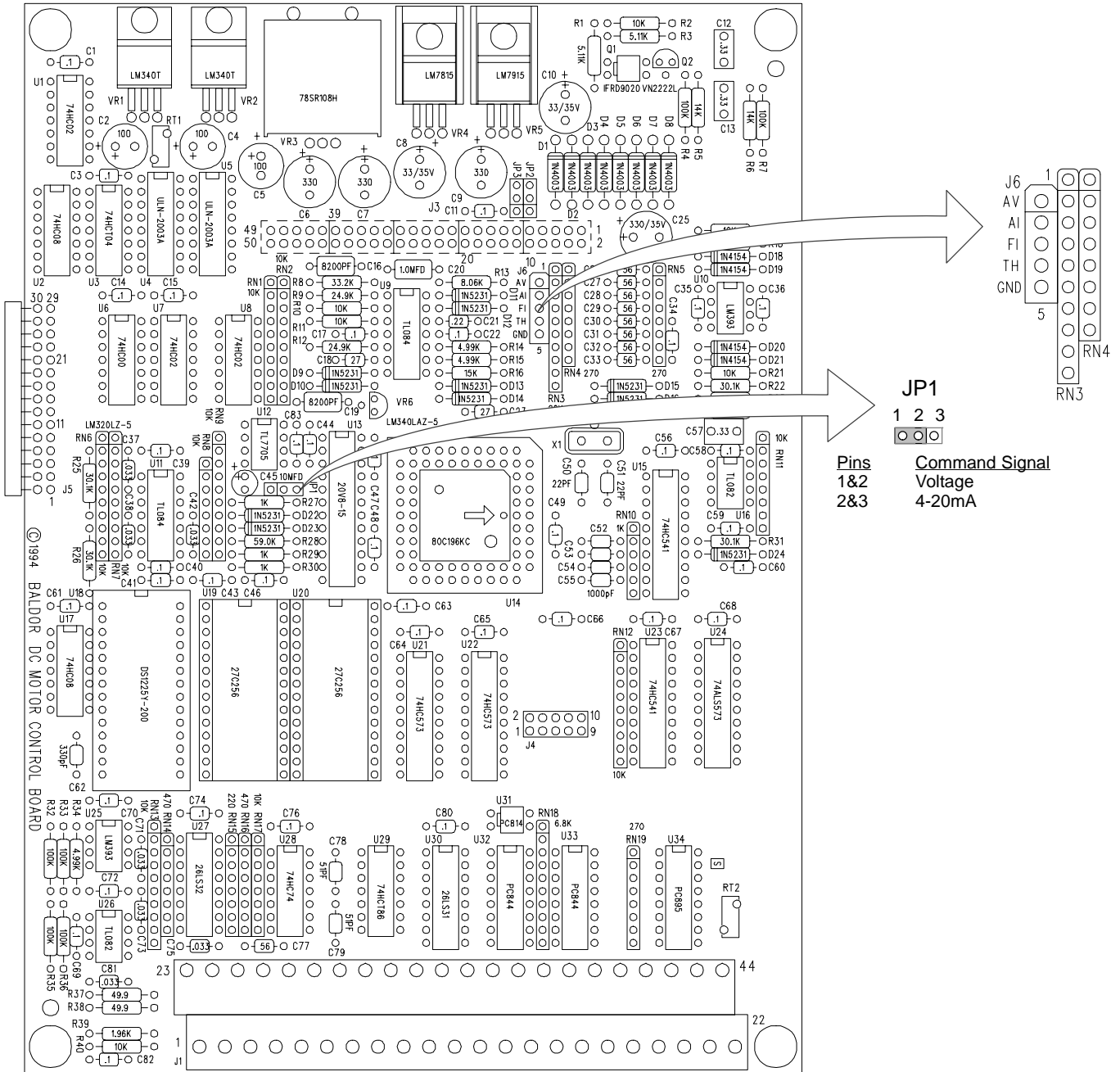

J6 Test Points

- AV ARM Volts (5VDC=+1000, 2.5VDC=0, 0VDC=-1000)
- AI ARM Current (5VDC=125% at Rating, 0VDC=-125% at Rating)
- FI Field Current (5VDC=50 AT, 0VDC=0 AT)
- TH Heatsink Temperature (4VDC=100°C)
- GND Ground

Electrical Noise Considerations All electronic devices are vulnerable to significant electronic interference signals (commonly called “Electrical Noise”). At the lowest level, noise can cause intermittent operating errors or faults. From a circuit standpoint, 5 or 10 millivolts of noise may cause abnormal operation.

At the extreme level, significant noise can cause damage to the drive. Therefore, it is advisable to prevent noise generation and to follow wiring practices that prevent noise generated by other devices from reaching sensitive circuits. In a control, such circuits include inputs for speed, torque, control logic, and speed and position feedback, plus outputs to some indicators and computers.

Relay and Contactor Coils Among the most common sources of noise is the coil of a contactor or a relay. When these highly inductive coil circuits are opened, transient conditions often generate spikes of several hundred volts in the control circuit. These spikes can induce several volts of noise in an adjacent wire that runs parallel to a control-circuit wire.

Figure 4-2 illustrates noise suppression for AC and DC operated coils.

Figure 4-2 AC & DC Coil Noise Suppression

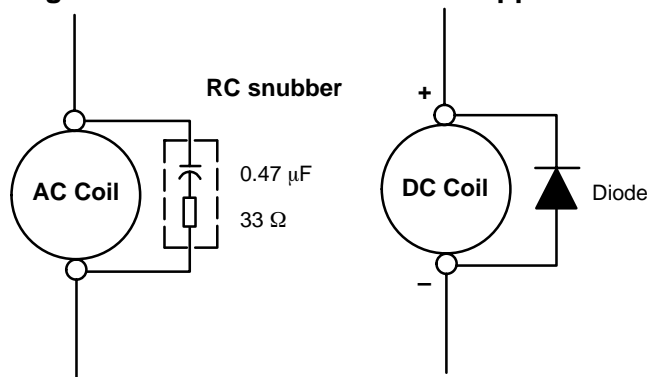

Wires between Controls and Motors

Output leads from a typical 460 VAC drive controller contain rapid voltage rises created by power semiconductors switching 650V in less than a microsecond, 1,000 to 10,000 times a second. These noise signals can couple into sensitive drive circuits. If shielded pair cable is used, the coupling is reduced by nearly 90% compared to unshielded cable.

Even input AC power lines contain noise and can induce noise in adjacent wires. In some cases, line reactors may be required.

To prevent induced transient noise in signal wires, all motor leads and AC power lines should be contained in rigid metal conduit, or flexible conduit. Do not place line conductors and load conductors in same conduit. Use one conduit for 3 phase input wires and another conduit for the motor leads. The conduits should be grounded to form a shield to contain the electrical noise within the conduit path. Signal wires - even ones in shielded cable should never be placed in the conduit with motor power wires.

Special Drive Situations

For severe noise situations, it may be necessary to reduce transient voltages in the wires to the motor by adding load reactors. Load reactors are installed between the control and motor.

Reactors are typically 3% reactance and are designed for the frequencies encountered in PWM drives. For maximum benefit, the reactors should be mounted in the drive enclosure with short leads between the control and the reactors.

Control Enclosures

Motor controls mounted in a grounded enclosure should also be connected to earth ground with a separate conductor to ensure best ground connection. Often grounding the control to the grounded metallic enclosure is not sufficient. Usually painted surfaces and seals prevent solid metallic contact between the control and the panel enclosure. Likewise, conduit should never be used as a ground conductor for motor power wires or signal conductors.

Special Motor Considerations

Motor frames must also be grounded. As with control enclosures, motors must be grounded directly to the control and plant ground with as short a ground wire as possible. Capacitive coupling within the motor windings produces transient voltages between the motor frame and ground. The severity of these voltages increases with the length of the ground wire. Installations with the motor and control mounted on a common frame, and with heavy ground wires less than 10 ft. long, rarely have a problem caused by these motor-generated transient voltages.

Sometimes motor frame transient voltages are capacitively coupled to feedback devices mounted on the motor shaft. To prevent this problem, add electrical isolation between the motor and the feedback device. The most simple isolation method, shown in Figure NO TAG, has two parts: 1) A plate of electrical insulating material placed between the motor mounting surface and the feedback device. 2) An insulating coupling between motor shaft and the shaft of the feedback device.

Figure 4-3 Isolated Mounting Method

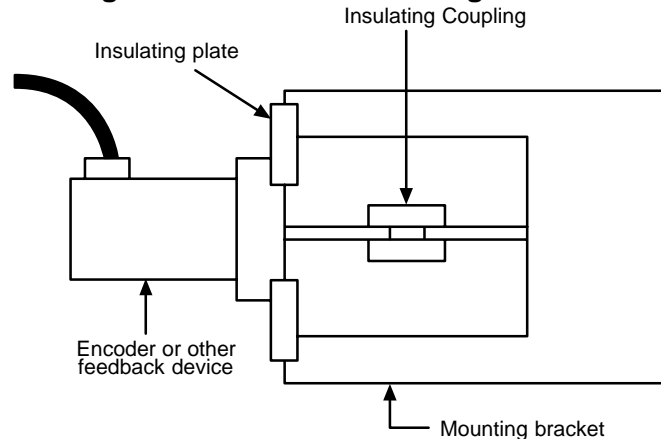

Analog Signal Wires

Analog signals generally originate from speed and torque controls, plus DC tachometers and process controllers. Reliability is often improved by the following noise reduction techniques:

- Use twisted-pair shielded wires with the shield grounded at the drive end only.
- Route analog signal wires away from power or control wires (all other wiring types).
- Cross power and control wires at right angles (90°) to minimize inductive noise coupling.

Wiring Practices

The type of wire used and how it is installed for specific applications makes the difference between obtaining reliable operation and creating additional problems.

Power Wiring

Conductors carrying power to anything (motor, heater, brake coil, or lighting units, for example) should be contained in conductive conduit that is grounded at both ends. These power wires must be routed in conduit separately from signal and control wiring.

Control–logic Conductors

Typically, operator's controls (push buttons and switches), relay contacts, limit switches, PLC I/O's, operator displays, and relay and contactor coils operate at 115VAC or 24VDC. Although these devices usually operate at low current levels, they contain switching noise caused by contact open/closure and solid–state switch operations. Therefore, these wires should be routed away from sensitive signal wires and contained within conduits or bundled away from open power and signal wires.

DC Tachometer Circuits

Among the most sensitive circuits is the DC Tachometer. Reliability of a DC tachometer circuit is often improved by the following noise reduction techniques:

- Connect a 0.1 μF capacitor across the tachometer terminals to suppress AC noise.
- Use twisted-pair shielded wires with the shield grounded at the control end only. You should avoid grounding the shield to the tachometer case or conduit.
- Follow the practices for analog signal wiring.

Analog Signal Wires

Analog signals generally originate from speed and torque controls, plus DC tachometers and process controllers. Reliability is often improved by the following noise reduction techniques:

- Use twisted-pair shielded wires with the shield grounded at the drive end only.
- Route analog signal wires away from power or control wires (all other wiring types).
- Cross power and control wires at right angles (90°) to minimize inductive noise coupling.

Encoder Circuits

Adjustable speed drives are especially sensitive to high frequency noise on encoder signal lines. Because these input signals cannot be heavily filtered special care must be taken to avoid transient noise from entering these signal lines. Drive reliability can be greatly improved by using the following noise reduction techniques:

- Use line driver output encoders to reduce the encoder output impedance.
- Select line driver inputs on the adjustable speed drive.
- Install twisted-pair shielded wire for power to the encoder and having each output with its own return. (Avoid common conductors with multiple outputs or with an output and the power source.)
- Never connect the encoder ground to the power ground terminal of the control.
- Run all encoder wires independently from all other power wires.

Plant Ground

Connecting electrical equipment to a good ground is essential for safety and reliable operation. In many cases, what is perceived as a ground isn't.

Result: equipment malfunctions or electrical shock hazard exists.

It may be necessary to retain the services of an electrical consultant, who is also a licensed professional engineer experienced in grounding practices to make the necessary measurements to establish if the plant ground is really grounded.

Section 5

Specifications and Product Data

Specifications:

Enclosure:	Open Type (Chassis Mount)
Horsepower	2-50 HP @ 115VAC 3-125 HP @ 230VAC 5-600 HP @ 460VAC
Input Frequency	50/60 HZ \pm 5%
Output Voltage	0 to (1.13 x Input VAC)VDC (REGEN) 0 to (1.30 x Input VAC)VDC (ONE-WAY)
Output Current	See Ratings Table 5-1
Service Factor	1.0
Duty	Continuous
Overload Capacity	See Ratings Table 5-1
Rated Storage Temperature:	- 30 °C to +65 °C

Operating Conditions:

Voltage Range:	115 VAC Models 230 VAC Models 460 VAC Models ¹	105-130 VAC 3 ϕ 60 Hz 180-264 VAC 3 ϕ 60 Hz / 180-230 VAC 3 ϕ 50 Hz 340-528 VAC 3 ϕ 60 Hz / 340-460 VAC 3 ϕ 50 Hz
Input Frequency Variation:		\pm 5%, 8.0Hz/Second Maximum Slew Rate
Input Line Impedance:		5% Maximum
Ambient Operating Temperature:		0 to +40 °C Derate Output 2% per °C over 40 °C to 55 °C Max
Ambient Temperature:		0 °C to +40 °C
Humidity:		10 to 90% RH Non-Condensing
Altitude:		Sea level to 3300 Feet (1000 Meters) Derate 2% per 1000 Feet (303 Meters) above 3300 Feet
Shock:		1G
Vibration:		0.5G at 10Hz to 60Hz

¹ 460VAC control requires 230VAC 1 ϕ for cooling fans on some B and C size controls. See Table 5-1.

Keypad Display:

Display	Backlit LCD Alphanumeric 2 Lines x 16 Characters
Keys	12 key membrane with tactile response
Functions	Output status monitoring Digital speed control Parameter setting and display Diagnostic and Fault log display Motor run and jog Local/Remote toggle
LED Indicators	Forward run command Reverse run command Stop command Jog active
Remote Mount	100 feet (30.3m) max from control

Control Specifications:

Control Method	Three phase, full wave, bi-directional regenerative DC control with 6 total pulses per cycle and 6 controlled pulses per cycle. NEMA Type C.
Speed Regulation Feedback Type:	
Armature	1% of base speed
Encoder	0.1% of set speed
Tachometer (optional)	1% of set speed
Resolver (optional)	0.1% of set speed
Current (Rate Limit) - Time to peak current	0.008 Seconds - 1.0 Seconds
Accel / Decel Time	0 - 3600 Seconds for 2 assignable presets plus JOG
S-Curve Time	0 - 100%
JOG Speed	0 - Maximum speed
Minimum Output Speed	0 - Maximum speed
Maximum Output Speed	0 - Maximum speed
Auto Restart	Manual or Automatic
IR Compensation Gain	Available for Armature Feedback
Velocity Loop Bandwidth	Adjustable to 20Hz
Current Loop Bandwidth	Adjustable to 70Hz
Selectable Operating Modes	Keypad Standard Run 3 Wire 2 Wire Control with 15 Presets Serial Bipolar Speed/Torque Process Mode Bipolar Hoist Seven Speed Hoist, 2 Wire

Field Power Supply:

Type	Voltage Limited, Current Regulated Full Wave Single Phase
Voltage	0-85% of AC Line Input (in DC Volts)
Current	0.1 - 15 Amperes maximum standard (Standard to 300HP) 0.3 - 40 Amperes maximum optional (Standard \geq 400HP) Off for Permanent Magnet Motors
Field Economy Level	Off, 25 - 100%
Field Forcing Level (hoist modes only)	100 - 125%

Differential Analog Input:

Common Mode Rejection	40 db
Full Scale Range	\pm 5VDC, \pm 10VDC, 4-20 mA
Auto-selectable Resolutions	12 bits + sign below 1VDC command 9 bits + sign above 1VDC command
Update rate	2.7 msec with a 60Hz line

Other Analog Input:

Full Scale Range	\pm 10 VDC
Resolution	9 bits + sign
Update Rate	2.7 msec with a 60Hz line

Analog Outputs:

Analog Outputs	2 Assignable
Full Scale Range	0 - 5 VDC
Source Current	1 mA maximum
Resolution	8 bits
Update Rate	2.7 msec with a 60Hz line

Digital Inputs:

Opto-isolated Logic Inputs	9 Assignable
Rated Voltage	10 - 30 VDC (closed contacts standard)
Input Impedance	6.8 K Ohms
Leakage Current	10 μ A maximum
Update Rate	16.6 msec

Digital Outputs:

Opto-isolated Logic Outputs	4 Assignable
ON Current Sink	60 mA Max
ON Voltage Drop	2 VDC Max
Update Rate	16.6 msec
Maximum Voltage	30 VDC

Diagnostic Indications:

Current Sense Fault	Ready	Following Error
Instantaneous Over Current	Parameter Loss	Encoder Loss
Microprocessor Failure	Overload	Tach Loss
Over temperature (Control)	Torque Proving	Field Loss
Over speed	Expansion Board Fault	Resolver Loss
ARM Volts Sense Fault	External Trip (Motor Over Temp)	Invalid Power Base ID
Field Sense Fault	High Line Fault	Phase Loss
Check Tach Jumpers	Low Line Fault	

Note: All specifications are subject to change without notice.

Ratings

Table 5-1 Ratings

Input VAC	Catalog Number	Max. Output					Size	Cooling Blower Voltage	Blower Power Requirement
		Volts	HP	KW	RMS Amps	Peak Amps			
115	BC20H103-CL	140	3	2.2	20	60	A	–	–
115	BC20H107-CL	140	7	5.2	40	120	A	–	–
115	BC20H110-CL	140	10	7.5	60	150	A	–	–
115	BC20H115-CL	140	15	11.2	75	190	B	–	–
115	BC20H120-CL	140	20	14.9	100	250	B	① 115VAC	1x24 Watt
115	BC20H125-CL	140	25	18.6	140	420	C	① 115VAC	2x24 Watt
115	BC20H135-CL	140	35	26	180	480	C	① 115VAC	2x24 Watt
115	BC20H140-CL	140	40	29.8	210	540	C	① 115VAC	2x24 Watt
115	BC20H150-CL	140	50	37.3	270	680	C	① 115VAC	1x1.9 Watt
230	BC20H205-CL	240	5	3.7	20	60	A	–	–
230	BC20H210-CL	240	10	7.5	40	120	A	–	–
230	BC20H215-CL	240	15	11.2	60	150	A	–	–
230	BC20H220-CL	240	20	14.9	75	190	B	–	–
230	BC20H225-CL	240	25	18.6	100	250	B	230 VAC	1x24 Watt
230	BC20H240-CL	240	40	29.8	140	420	C	230 VAC	2x24 Watt
230	BC20H250-CL	240	50	37.3	180	480	C	230 VAC	2x24 Watt
230	BC20H260-CL	240	60	44.8	210	540	C	230 VAC	2x24 Watt
230	BC20H275-CL	240	75	56	270	680	C	230/460 VAC	1x.95A/.48A
230	BC20H2125-CL	240	125	93	420	1050	D	230/460 VAC	1x.95A/.48A
460	BC20H410-CL	500	10	7.5	20	60	A	–	–
460	BC20H420-CL	500	20	14.9	40	120	A	–	–
460	BC20H430-CL	500	30	22.4	60	150	A	–	–
460	BC20H440-CL	500	40	29.8	75	190	B	–	–
460	BC20H450-CL	500	50	37.3	100	250	B	① 115VAC	1x24 Watt
460	BC20H475-CL	500	75	56	140	420	C	230/460VAC	1x.95A/.48A
460	BC20H4100-CL	500	100	74.6	180	480	C	230/460VAC	1x.95A/.48A
460	BC20H4125-CL	500	125	93	210	530	C	230/460VAC	1x.95A/.48A
460	BC20H4150-CL	500	150	112	270	680	C	230/460VAC	1x.95A/.48A
460	BC20H4200-CL	500	200	149	350	875	D	230/460VAC	1x.95A/.48A
460	BC20H4250-CL	500	250	187	420	1050	D	230/460VAC	1x.95A/.48A
460	BC20H4300-CL	500	300	224	500	1250	D	230/460VAC	1x.95A/.48A
460	BC20H4400-EL	500	400	298	670	1340	G	–	Internal Connection
460	BC20H4500-EL	500	500	373	840	1680	G	–	Internal Connection
460	BC20H4600-EL	500	600	448	960	1920	G	–	Internal Connection

① Controls built before 2nd quarter 1996 have 230VAC fans.

Peak Amps are Rated for 3 Seconds Maximum.

150% of motor amps – 60 seconds

200% of motor amps – 8 seconds

300% of motor amps – 3 seconds

(Within peak current capacity limits of control)

Note: All specifications are subject to change without notice.

Torque Specifications

Table 5-2 Tightening Torque Specifications

Catalog Number	L1, L2 & L3		A1		A2		Field Power		J1		Ground Lug		Thermal Terminals		Control Ground	
	lb-in	Nm	lb-in	Nm	lb-in	Nm	lb-in	Nm	lb-in	Nm	lb-in	Nm	lb-in	Nm	lb-in	Nm
BC20H103-CL	160	18.1	30	3.4	30	3.4	12	1.4	7	0.8	50	5.6	5	.56	5	.56
BC20H107-CL	160	18.1	30	3.4	30	3.4	12	1.4	7	0.8	50	5.6	5	.56	5	.56
BC20H110-CL	160	18.1	30	3.4	30	3.4	12	1.4	7	0.8	50	5.6	5	.56	5	.56
BC20H115-CL	275	31	200	22.6	275	31	5	.56	7	0.8	200	22.6	5	.56	5	.56
BC20H120-CL	275	31	200	22.6	275	31	5	.56	7	0.8	200	22.6	5	.56	5	.56
BC20H125-CL	275	31	200	22.6	275	31	5	.56	7	0.8	200	22.6	5	.56	5	.56
BC20H135-CL	275	31	200	22.6	275	31	5	.56	7	0.8	200	22.6	5	.56	5	.56
BC20H140-CL	275	31	200	22.6	275	31	5	.56	7	0.8	200	22.6	5	.56	5	.56
BC20H150-CL	275	31	200	22.6	275	31	5	.56	7	0.8	200	22.6	5	.56	5	.56
BC20H205-CL	160	18.1	30	3.4	30	3.4	12	1.4	7	0.8	50	5.6	5	.56	5	.56
BC20H210-CL	160	18.1	30	3.4	30	3.4	12	1.4	7	0.8	50	5.6	5	.56	5	.56
BC20H215-CL	160	18.1	30	3.4	30	3.4	12	1.4	7	0.8	50	5.6	5	.56	5	.56
BC20H220-CL	275	31	200	22.6	275	31	5	.56	7	0.8	200	22.6	5	.56	5	.56
BC20H225-CL	275	31	200	22.6	275	31	5	.56	7	0.8	200	22.6	5	.56	5	.56
BC20H240-CL	275	31	200	22.6	275	31	5	.56	7	0.8	200	22.6	5	.56	5	.56
BC20H250-CL	275	31	200	22.6	275	31	5	.56	7	0.8	200	22.6	5	.56	5	.56
BC20H260-CL	275	31	200	22.6	275	31	5	.56	7	0.8	200	22.6	5	.56	5	.56
BC20H275-CL	275	31	200	22.6	275	31	5	.56	7	0.8	200	22.6	5	.56	5	.56
BC20H410-CL	160	18.1	30	3.4	30	3.5	12	1.4	7	0.8	50	5.6	5	.56	5	.56
BC20H420-CL	160	18.1	30	3.4	30	3.5	12	1.4	7	0.8	50	5.6	5	.56	5	.56
BC20H430-CL	160	18.1	30	3.4	30	3.5	12	1.4	7	0.8	50	5.6	5	.56	5	.56
BC20H440-CL	275	31	200	22.6	275	31	5	.56	7	0.8	200	22.6	5	.56	5	.56
BC20H450-CL	275	31	200	22.6	275	31	5	.56	7	0.8	200	22.6	5	.56	5	.56
BC20H475-CL	275	31	200	22.6	275	31	5	.56	7	0.8	200	22.6	5	.56	5	.56
BC20H4100-CL	275	31	200	22.6	275	31	5	.56	7	0.8	200	22.6	5	.56	5	.56
BC20H4125-CL	275	31	200	22.6	275	31	5	.56	7	0.8	200	22.6	5	.56	5	.56
BC20H4150-CL	275	31	200	22.6	275	31	5	.56	7	0.8	200	22.6	5	.56	5	.56
BC20H4200-CL	375	42.4	375	42.4	375	42.4	5	.56	7	0.8	200	22.6	5	.56	5	.56
BC20H4250-CL	375	42.4	375	42.4	375	42.4	5	.56	7	0.8	200	22.6	5	.56	5	.56
BC20H4300-CL	375	42.4	375	42.4	375	42.4	5	.56	7	0.8	200	22.6	5	.56	5	.56
BC20H4400-EL	375	42.4	375	42.4	375	42.4	32	3.5	7	0.8	375	42.4	5	.56	5	.56
BC20H4500-EL	375	42.4	375	42.4	375	42.4	32	3.5	7	0.8	375	42.4	5	.56	5	.56
BC20H4600-EL	375	42.4	375	42.4	375	42.4	32	3.5	7	0.8	375	42.4	5	.56	5	.56

Inter-connect Diagram

Size A – D Controls

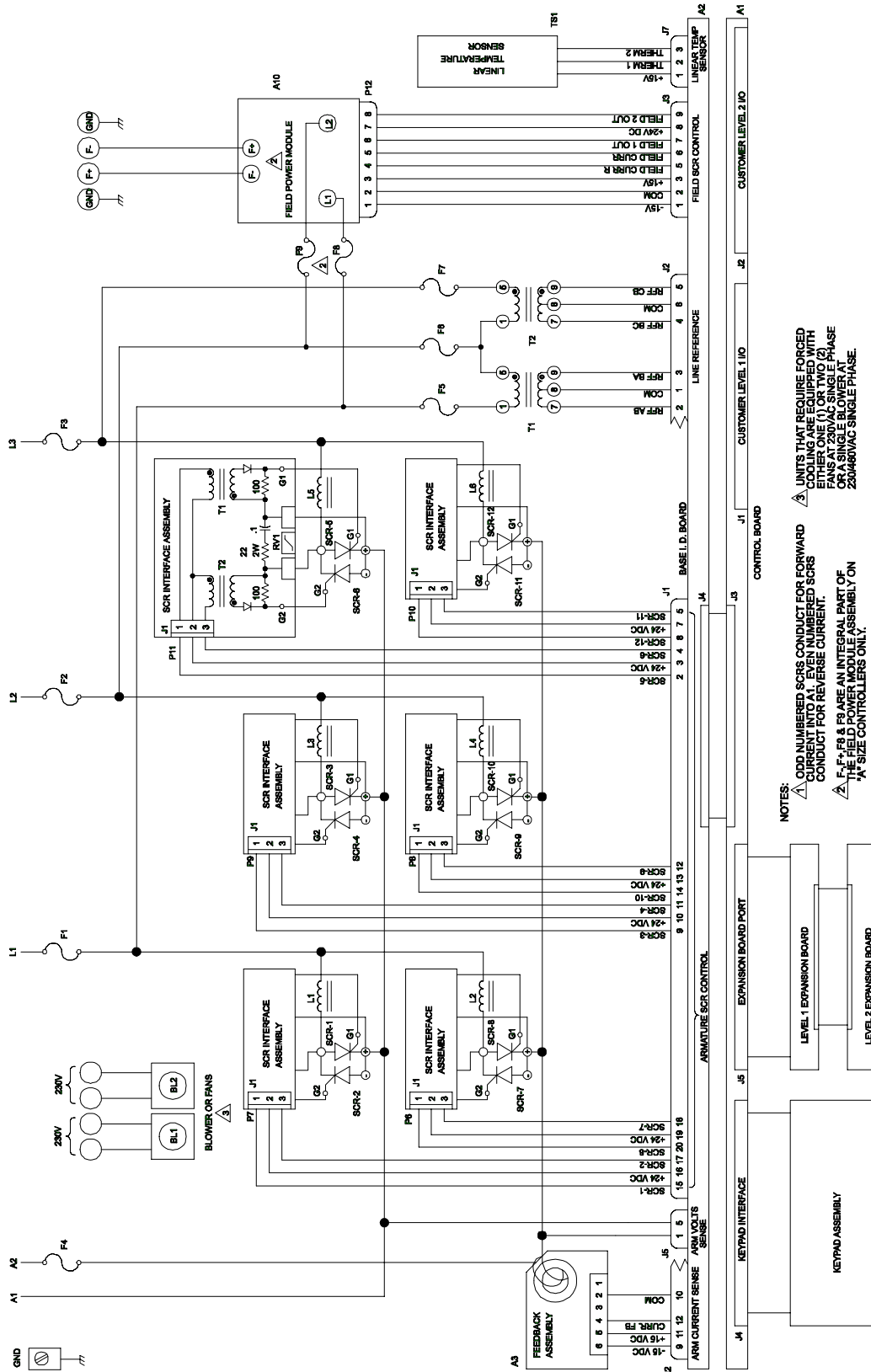

NOTES:

- ▲ ODD NUMBERED SCRS CONDUCT FOR FORWARD CURRENT INTO ALL EVEN NUMBERED SCRS CONDUCT FOR REVERSE CURRENT.
- ▲ F1, F2, F3 & F8 ARE AN INTEGRAL PART OF THE FIELD POWER MODULE ASSEMBLY ON "A" SIZE CONTROLLERS ONLY.
- ▲ UNITS THAT REQUIRE FORCED COOLING ARE EQUIPPED WITH FANS AT 230V AC SINGLE PHASE OR A SINGLE BLOWER AT 230/480VAC SINGLE PHASE.

Dimensions

Size A Control

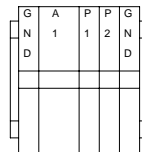
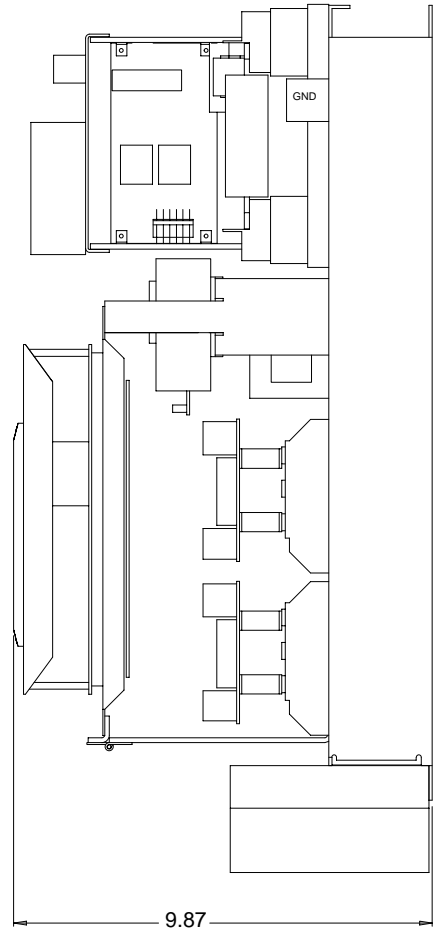
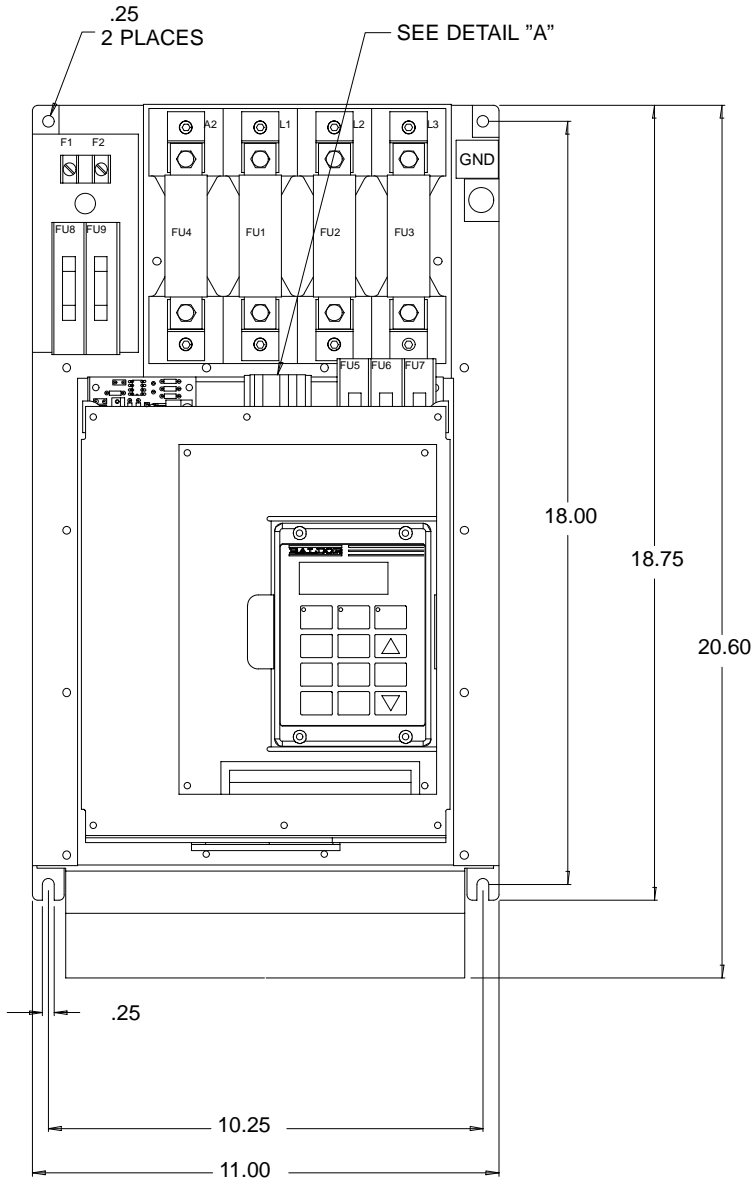

DETAIL "A"

Dimensions Continued

Size B Control

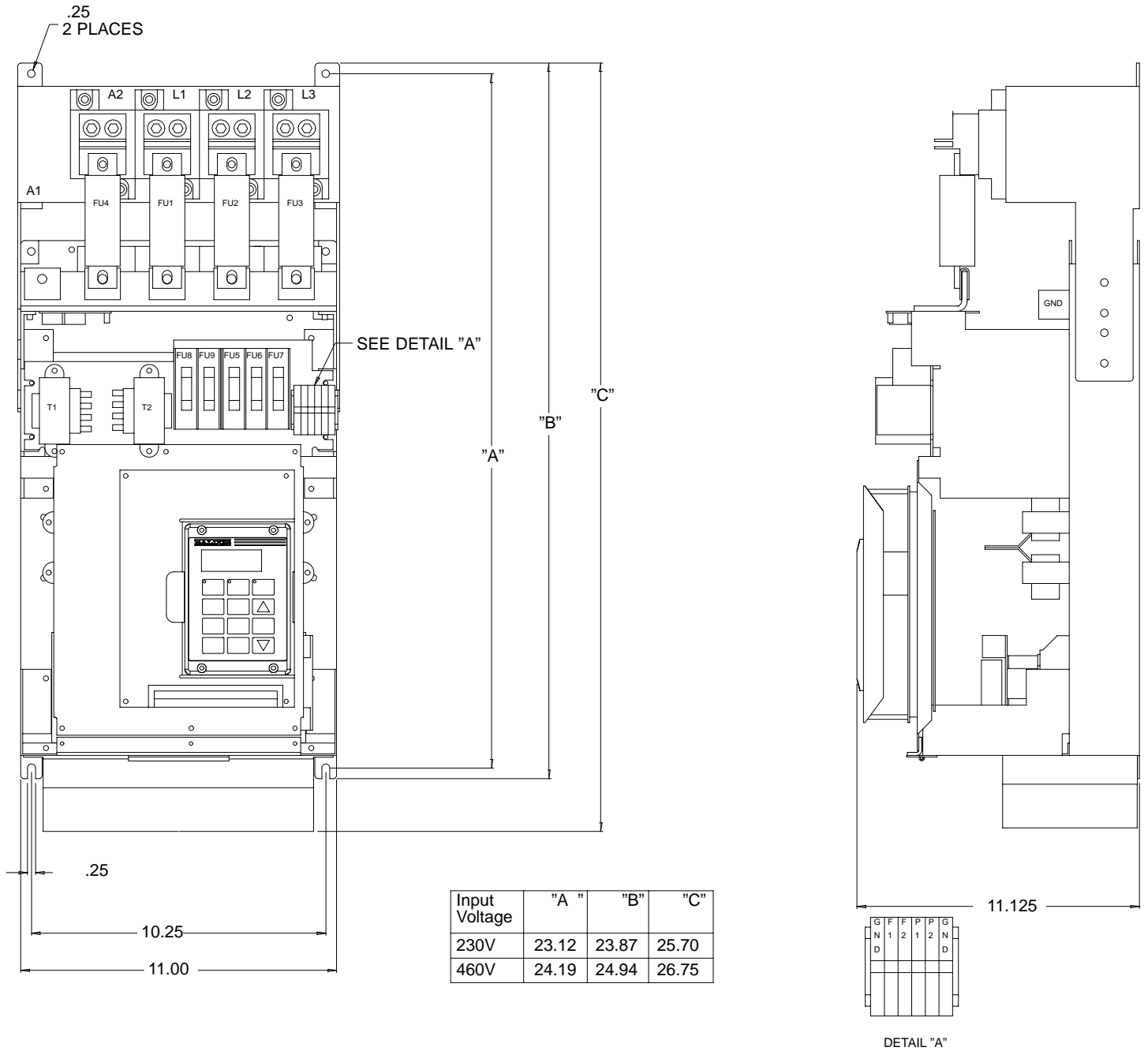

Dimensions Continued

Size C Control

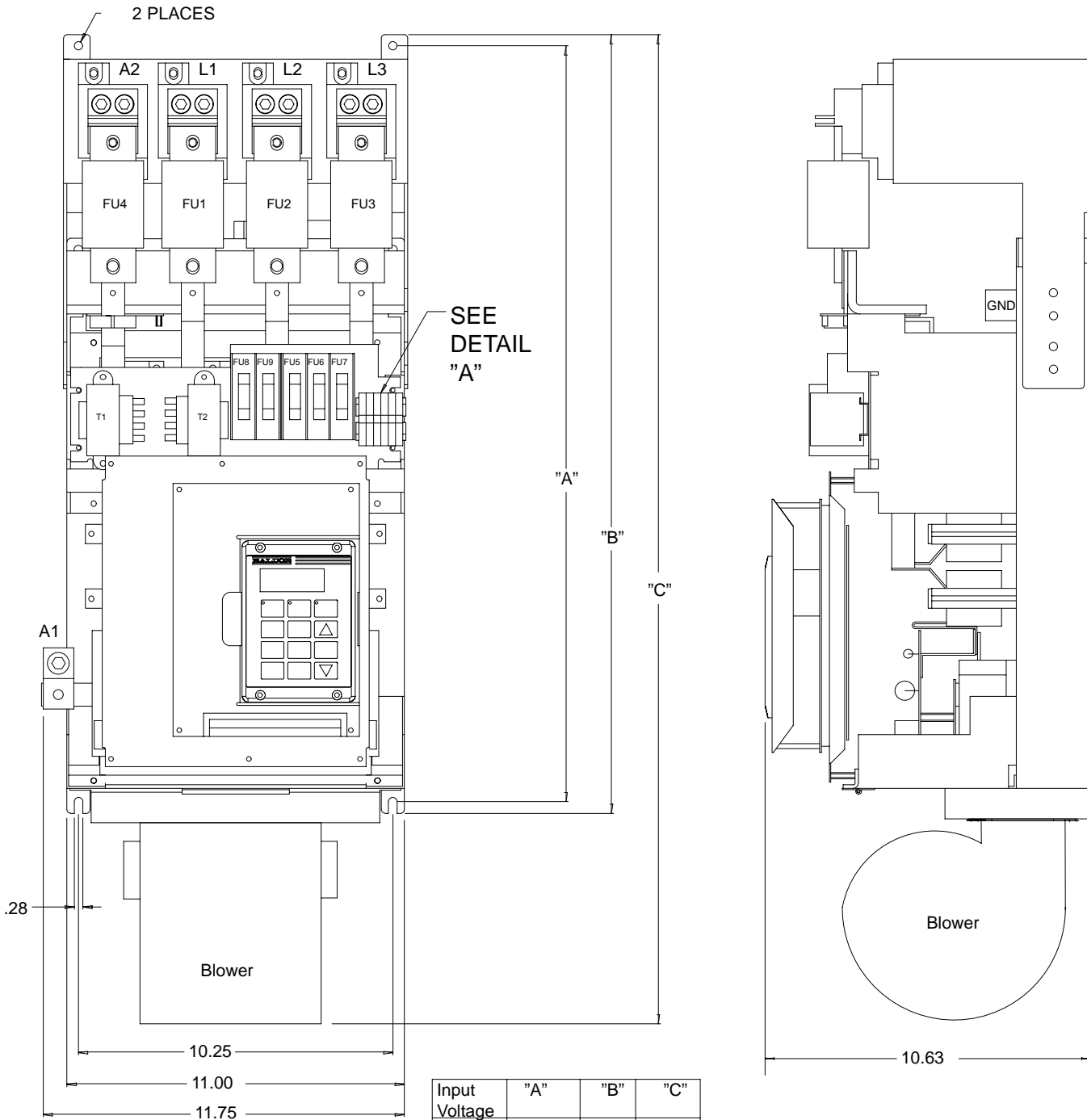

Input Voltage	"A"	"B"	"C"
230V	23.90	24.65	32.90
460V	24.65	25.40	33.65

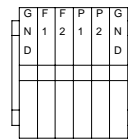

DETAIL "A"

Dimensions Continued
Size D Control

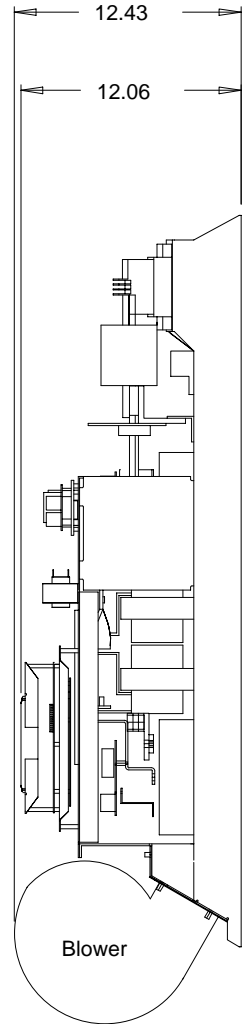
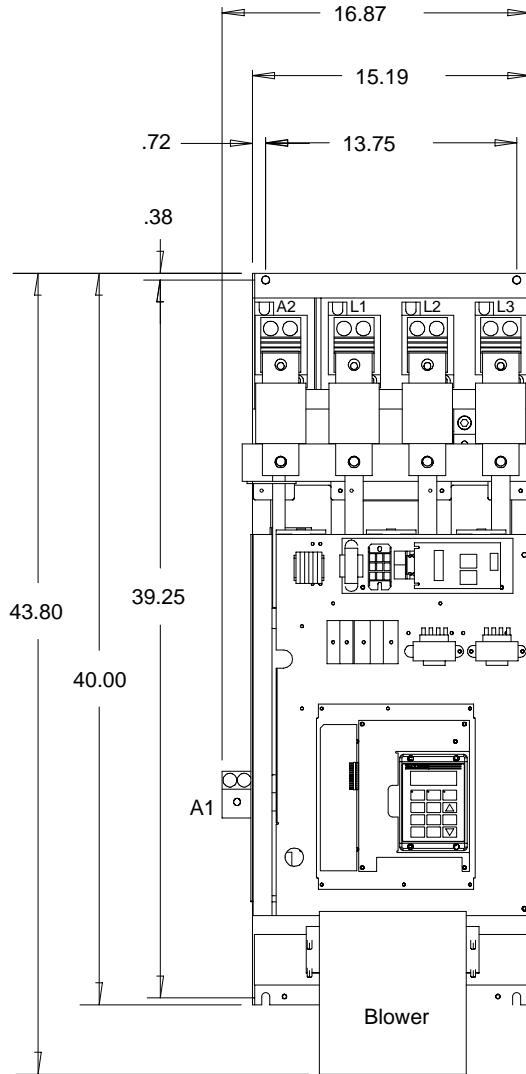

Dimensions Continued

Size G Control

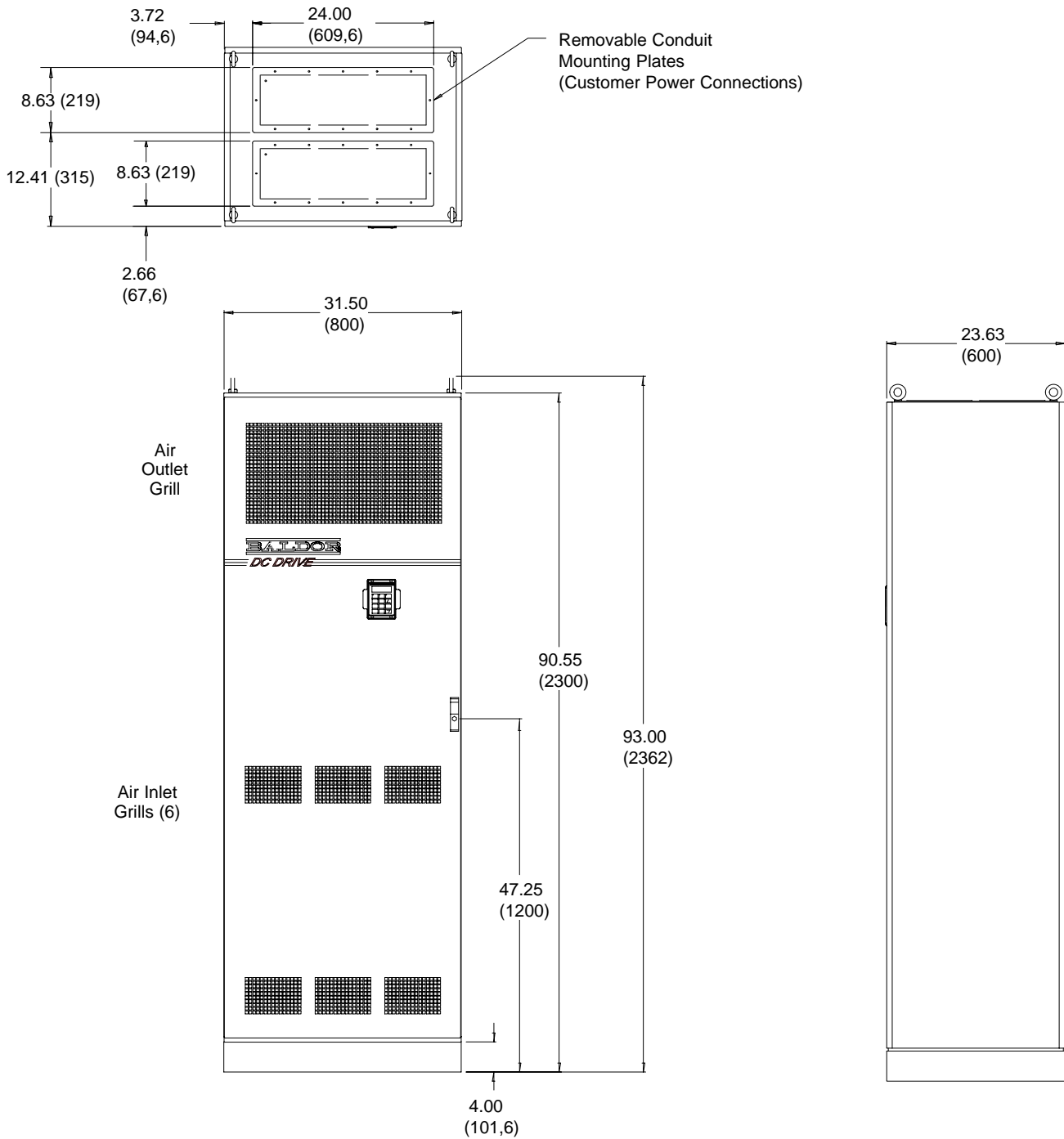

Appendix A

Field Supply Module

The standard field supply modules provide up to 85% of the incoming AC voltage as its maximum DC output voltage. Standard output current is 15 amps mounted to the control chassis with an optional separately mounted 40 amp maximum supply available from Baldor Electric.

It is possible to run motors with fields above 85% of the incoming AC voltage with the Series 20H control. Doing so requires a voltage step-up transformer to be added between the field supply module's LI – L2 connection. Note that this connection is phase sensitive with LI and L2. Maximum AC input voltage to the field supply module should be limited to 528 VAC on 60 Hz.

Required step up transformer is calculated:

$$\text{Minimum AC Input Volts} = \frac{\text{Required Maximum Motor Field Voltage}}{0.85}$$

Example:

Motor field volts required is 300 VDC, AC input is 230 VAC

$$\frac{\text{Required Maximum Motor Field Voltage}}{0.85} = \frac{300}{0.85} = 366\text{VAC Minimum AC Input}$$

Minimum step-up ratio for the transformer is calculated:

$$\frac{\text{Calculated Minimum AC Input Volts}}{\text{AC Line Input Volts}}$$

Transformer KVA is calculated by:

Transformer KVA = Max Field Volts x Max Field Amps

In the case of the voltage step-up transformer, the FIELD RATED VOLTS parameter should be calculated by:

$$\text{Field Rated Volts} = \text{Rated Field Volts} \times \frac{\text{Input Volts}}{\text{Output Volts}}$$

Example from above:

$$\text{Field Rated Volts} = 300\text{VDC} \times \left(\frac{230}{366}\right) = 188\text{VDC}$$

The standard field connection is shown in Figure A-1.

Figure A-1 Standard Field Connection

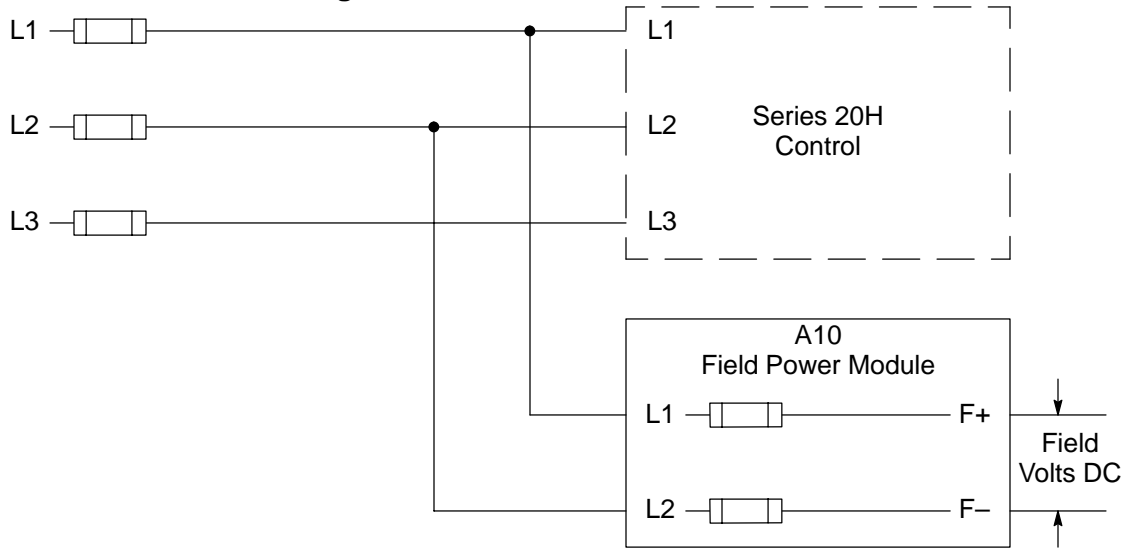

When using a transformer to boost the AC input to the field supply module to get a field voltage more than 85% of the AC line will be connected as shown in Figure A-2.

Figure A-2 Field Transformer Connection (to increase field output voltage)

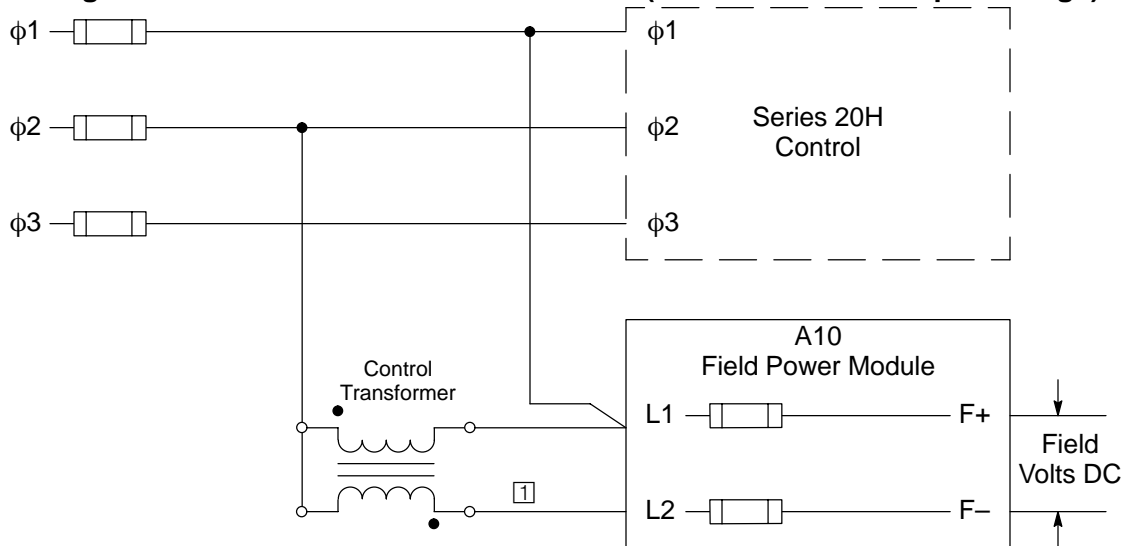

① Note that the wire that connects $\phi 2$ with L2 of the Field Power Module is removed and the control transformer is connected.

1. Output field voltage is adjusted as specified for the application.

2. Maximum Motor Field Voltage = $0.85 \times V_{L1-L2}$

3. $V_{L1-L2} = V_{\phi 1-\phi 2} + N \times V_{\phi 1-\phi 2}$

Where N=Control transformer voltage ratio (Secondary/Primary)

4. Minimum control transformer VA rating = (Maximum Field Amps DC) \times $NV_{\phi 1-\phi 2}$

Appendix B

Parameter Values

Parameter Block Values Level 1

Level 1 Blocks					
Block Title	Parameter	P#	Adjustable Range	Factory Setting	User Setting
PRESET SPEEDS	PRESET SPEED #1	1001	0-MAX Speed	0 RPM	
	PRESET SPEED #2	1002	0-MAX Speed	0 RPM	
	PRESET SPEED #3	1003	0-MAX Speed	0 RPM	
	PRESET SPEED #4	1004	0-MAX Speed	0 RPM	
	PRESET SPEED #5	1005	0-MAX Speed	0 RPM	
	PRESET SPEED #6	1006	0-MAX Speed	0 RPM	
	PRESET SPEED #7	1007	0-MAX Speed	0 RPM	
	PRESET SPEED #8	1008	0-MAX Speed	0 RPM	
	PRESET SPEED #9	1009	0-MAX Speed	0 RPM	
	PRESET SPEED #10	1010	0-MAX Speed	0 RPM	
	PRESET SPEED #11	1011	0-MAX Speed	0 RPM	
	PRESET SPEED #12	1012	0-MAX Speed	0 RPM	
	PRESET SPEED #13	1013	0-MAX Speed	0 RPM	
	PRESET SPEED #14	1014	0-MAX Speed	0 RPM	
	PRESET SPEED #15	1015	0-MAX Speed	0 RPM	
ACCEL/DECEL RATE	ACCEL TIME #1	1101	0 to 3600 Seconds	3.0 SEC	
	DECEL TIME #1	1102	0 to 3600 Seconds	3.0 SEC	
	S-CURVE #1	1103	0-100%	0 %	
	ACCEL TIME #2	1104	0 to 3600 Seconds	3.0 SEC	
	DECEL TIME #2	1105	0 to 3600 Seconds	3.0 SEC	
	S-CURVE #2	1106	0-100%	0 %	
JOG SETTINGS	JOG SPEED	1201	0-MAX Speed	200 RPM	
	JOG ACCEL TIME	1202	0 to 3600 Seconds	3.0 SEC	
	JOG DECEL TIME	1203	0 to 3600 Seconds	3.0 SEC	
	JOG S-CURVE TIME	1204	0-100%	0 %	
KEYPAD SETUP	KEYPAD STOP KEY	1301	REMOTE ON (Stop key active during remote operation). REMOTE OFF (Stop key inactive during remote operation).	REMOTE ON	
	KEYPAD STOP MODE	1302	COAST, REGEN	REGEN	
	KEYPAD RUN FWD	1303	ON, OFF	ON	
	KEYPAD RUN REV	1304	ON, OFF	ON	
	KEYPAD JOG FWD	1305	ON, OFF	ON	
	KEYPAD JOG REV	1306	ON, OFF	ON	

Parameter Block Values Level 1 Continued

Level 1 Blocks - Continued					
Block Title	Parameter	P#	Adjustable Range	Factory	User Setting
INPUT	OPERATING MODE	1401	KEYPAD STANDARD RUN 15SPD SERIAL BIPOLAR PROCESS MODE BIPLOAR HOIST 7 SPEED HOIST	KEYPAD	
	COMMAND SELECT	1402	POTENTIOMETER +/-10 VOLTS +/-5 VOLTS 4 TO 20 mA 10V W/EXT CL 10V W/TORQ FF EXB PULSE FOL 5V EXB 10V EXB 4-20mA EXB 3-15 PSI EXB TACHOMETER EXB SERIAL NONE	POTENTIO- METER	
	ANA CMD INVERSE	1403	ON, OFF	OFF	
	ANA 2 OFFSET	1404	-20% TO +20%	0.0	
	ANA 2 DEADBAND	1405	0-10.00 V	0.20 V	
OUTPUT	OPTO OUTPUT #1	1501	READY ZERO SPEED AT SPEED OVERLOAD	READY	
	OPTO OUTPUT #2	1502	KEYPAD CONTROL AT SET SPEED FAULT FOLLOWING ERR MOTR DIRECTION	ZERO SPEED	
	OPTO OUTPUT #3	1503	DRIVE ON CMD DIRECTION AT POSITION OVER TEMP WARN	AT SPEED	
	OPTO OUTPUT #4	1504	RUNNING FIELD PROCESS ERROR DRIVE RUN M/FWD CONTACT	FAULT	
	ZERO SPD SET PT	1505	0-MAX Speed	200 RPM	
	AT SPEED BAND	1506	±1000 RPM	100 RPM	
	SET SPEED	1507	0-MAX Speed	Rated Motor Speed	

Parameter Block Values Level 1 Continued

Level 1 Blocks - Continued					
Block Title	Parameter	P#	Adjustable Range	Factory	User Setting
OUTPUT (Continued)	ANALOG OUT #1	1508	ABS SPEED ABS TORQUE SPEED COMMAND FIELD CURRENT CMD FIELD CUR ARM CURRENT CMD ARM CUR FIRING ANGLE	ABS SPEED	
	ANALOG OUT #2	1509	ARM VOLTAGE FIELD VOLTAGE TORQUE POWER VELOCITY OVERLOAD POSITION LINE TIMER	ARM CURRENT	
	ANALOG #1 SCALE	1510	10-100%	100%	
	ANALOG #2 SCALE	1511	10-100%	100%	
	POSITION BAND	1512	0-32767 CNTS	CALC	
	DC CONTROL	CTRL BASE VOLTS	1601	0-1000	CALC
	FEEDBACK FILTER	1602	0-7	CALC	
	FEEDBACK ALIGN	1603	FORWARD, REVERSE	FORWARD	
	ARM PROP GAIN	1604	1-500	20	
	ARM INT GAIN	1605	0-30	10.0 Hz	
	SPEED PROP GAIN	1606	0-500	10	
	SPEED INT GAIN	1607	0-9.99 Hz	1.00 Hz	
	SPEED DIFF GAIN	1608	0-100	0	
	POSITION GAIN	1609	0-9999	CALC	
	IR COMP Gain	1610	0-1000	0	
	TACH TRIM	1611	90-110%	100%	
	NULL FORCE GAIN	1612	0-100	0	
	TACH Offset	1613	±2%	0%	
FIELD CONTROL	FIELD PWR SUPPLY	1701	NONE, 15 AMP MAX, 40 AMP MAX	15 AMP MAX	
	FIELD ECON LEVEL	1702	0, 25 - 100%	67%	
	FORCING LEVEL	1703	100 - 125%	100%	
	FIELD SET SPEED	1704	0 - MAX RPM	0	
	FIELD STEP LIMIT	1705	0 - 5 SEC	0	
	FIELD REG GAIN	1706	0 - 255	40	
	Field Integral	1707	OFF, ON	ON	
LEVEL 2 BLOCK	ENTERS LEVEL 2 MENU				
PRESS ENTER FOR PROGRAMMING EXIT	Exit programming mode and return to display mode.				

Parameter Block Values Level 2

Level 2 Blocks					
Block Title	Parameter	P#	Adjustable Range	Factory	User Setting
OUTPUT LIMITS	OPERATING ZONE	2001	ONE WAY, REGEN	REGEN	
	MIN OUTPUT SPEED	2002	0-MAX Speed	0 RPM	
	MAX OUTPUT SPEED	2003	0-5000 RPM	Rated Motor Speed	
	PK CURRENT LIMIT	2004	0-PEAK RATED CURRENT	1.5 X Motor ARM Rating	
	CUR RATE LIMIT	2006	0.008-1.00 SEC	CALC	
CUSTOM UNITS	DECIMAL PLACES	2101	0-5	0	
	VALUE AT SPEED	2102	0-65535/1000 RPM	00000/ 01000 RPM	
	UNITS OF MEASURE	2103	Selection of 9 Character Sets	-	
PROTECTION	OVERLOAD	2201	FAULT, FOLDBACK	FOLDBACK	
	EXTERNAL TRIP	2202	ON, OFF	OFF	
	FOLLOWING ERROR	2203	ON, OFF	OFF	
	TORQUE PROVING	2204	ON, OFF	OFF	
MISCELLANEOUS	RESTART AUTO/MAN	2301	AUTOMATIC, MANUAL	MANUAL	
	RESTART FAULT/HR	2302	0-10	0	
	RESTART DELAY	2303	0-120 SECONDS	0 SEC	
	FACTORY SETTINGS	2304	YES, NO	NO	
	HOMING SPEED	2305	0-MAX Speed	100 RPM	
	HOMING OFFSET	2306	0-65535 CNTS	Encoder Counts	
SECURITY CONTROL	SECURITY STATE	2401	OFF, LOCAL, SERIAL, TOTAL SECURITY	OFF	
	ACCESS TIMEOUT	2402	0-600 SEC	0 SEC	
	ACCESS CODE	2403	0-9999	9999	
MOTOR DATA	ARMATURE VOLTAGE	2501	0-600 VOLTS	Factory Set	
	ARM RATED AMPS	2502	0-999.9	Factory Set	
	MOTOR RATED SPD	2503	0-5000 RPM	1750 RPM	
	MOTOR FIELD	2504	SHUNT, PERM MAGNET	SHUNT	
	MOTOR FIELD VOLTS	2505	0-600	CALC	
	MOTOR FIELD AMPS	2506	0-40	0.3	
	FEEDBACK TYPE	2507	ARMATURE, ENCODER, TACHOMETER, RESOLVER	ARMATURE	
	ENCODER COUNTS	2508	50-65535 CNTS	1024 PPR	
	RESOLVER SPEEDS	2509	0 to 10	1	
	TACHOMETER VOLTS	2510	0 - 2000V PER 1000 RPM	50	
	PK POWER LIMIT	2511	50 - 300%	100	

Parameter Block Values Level 2 Continued

Level 2 Blocks - Continued					
Block Title	Parameter	P#	Adjustable Range	Factory	User Setting
PROCESS CONTROL	PROCESS FEEDBACK	2601	POTENTIOMETER +/-10VOLTS +/-5 VOLTS 4 TO 20mA 5V EXB 10V EXB 4-20mA EXB 3-15 PSI EXB TACHOMETER EXB NONE	NONE	
	PROCESS INVERSE	2602	ON, OFF	OFF	
	SETPOINT SOURCE	2603	SETPOINT CMD POTENTIOMETER +/-10VOLTS +/-5 VOLTS 4 TO 20mA 5V EXB 10V EXB 4-20mA EXB 3-15 PSI EXB TACHOMETER EXB NONE	SETPOINT CMD	
	SETPOINT COMMAND	2604	-100% to +100%	0.0 %	
	SET PT ADJ LIMIT	2605	0-100%	10.0 %	
	PROCESS ERR TOL	2606	1-100%	10 %	
	PROCESS PROP GAIN	2607	0-200	0	
	PROCESS INT GAIN	2608	0-9.99 HZ	0.00 HZ	
	PROCESS DIFF GAIN	2609	0-1000	0	
	FOLLOW I:O RATIO	2610	(1 - 65535) : (1 - 20)	1:1	
	FOLLOWER I:O OUT	2611	1-65535	1	
MASTER ENCODER	2612	50-65535	1024		

Parameter Block Values Level 2 Continued

Level 2 Blocks - Continued					
Block Title	Parameter	P#	Adjustable Range	Factory	User Setting
AUTO-TUNING	CALC PRESETS	CALC	YES, NO	NO	
	CMD OFFSET TRM Measures and trims out offset voltage at Analog Input #2 (J1-4 & J1-5).	AU1	-	-	
	CUR LOOP COMP Measures current response while running motor at one half the rated motor current.	AU2	-	-	
	FEEDBACK TESTS This procedure checks the values entered in Encoder Counts, Resolver Poles and Feedback direction. This is accomplished by accelerating the motor "open loop", detecting the phasing of encoder feedback and counting the number of encoder pulses per revolution of the motor. It also check for output when a DC tach is specified and sets the feedback direction. Press the ENTER key to run auto tuning test. Not required for ARMATURE FEEDBACK.	AU3	-	-	
	SPD CNTRLR CALC Measures the motor current to acceleration ratio during motor rotation. This procedure adjusts the Speed INT Gain and Speed PROP Gain parameters.	AU4	-	-	
LEVEL 1 BLOCK	Enters Level 1 Menu				
PRESS ENTER FOR PROGRAMMING EXIT	Exit programming mode and return to display mode.				

Appendix C

Remote Keypad Mounting Template

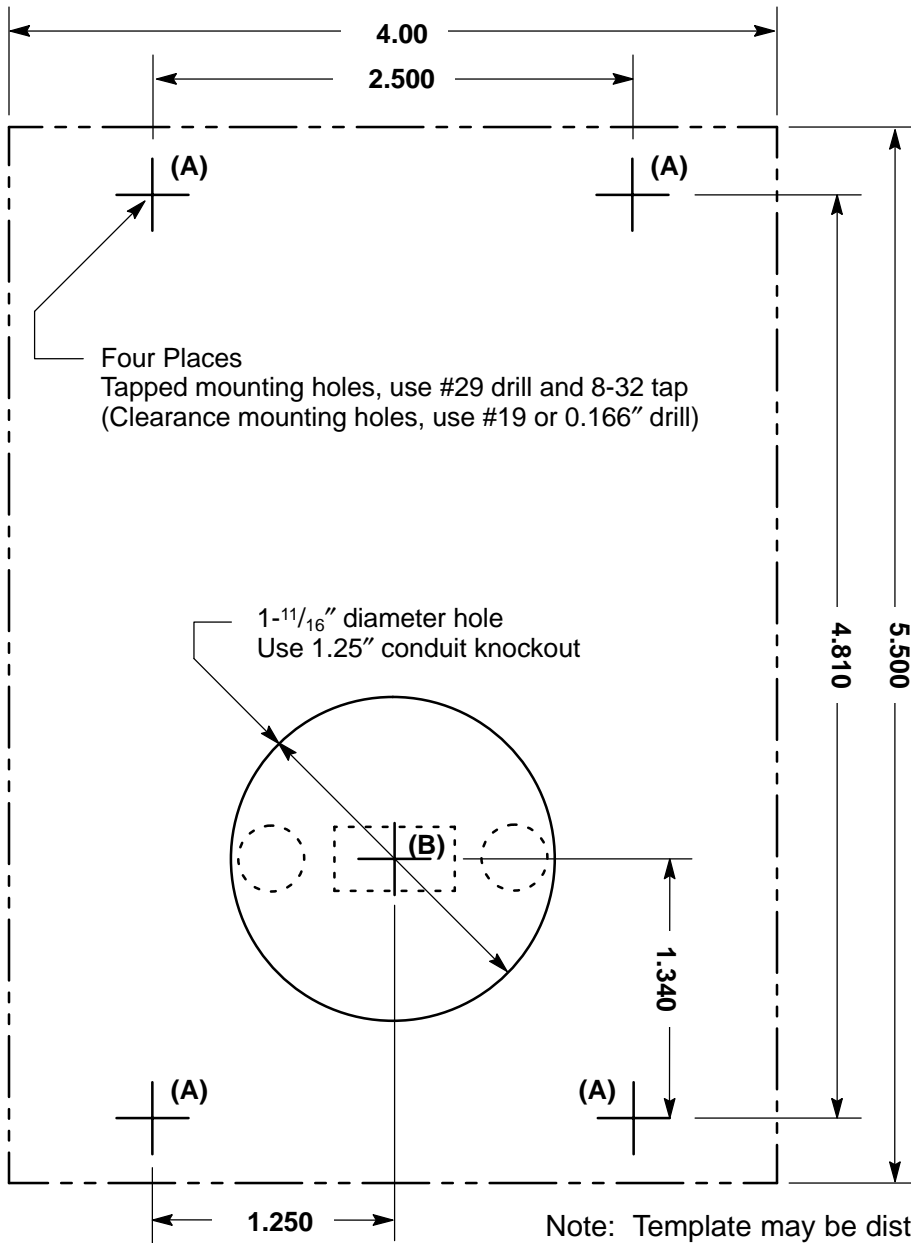

BALDOR[®] **MOTORS AND DRIVES**

BALDOR ELECTRIC COMPANY
P.O. Box 2400
Ft. Smith, AR 72902-2400
(501) 646-4711
Fax (501) 648-5792

CH TEL: +41 52 647 4700 FAX: +41 52 659 2394	D TEL: +49 89 90 50 80 FAX: +49 89 90 50 8491	UK TEL: +44 1454 850000 FAX: +44 1454 850001	F TEL: +33 145 10 7902 FAX: +33 145 09 0864
I TEL: +39 11 562 4440 FAX: +39 11 562 5660	AU TEL: +61 29674 5455 FAX: +61 29674 2495	CC TEL: +65 744 2572 FAX: +65 747 1708	MX TEL: +52 47 61 2030 FAX: +52 47 61 2010

M41A04

Series 20H Line Regenerative DC SCR Control

MN720