

SAILING INSTRUCTIONS

Colonial Cup Regatta

Snipe Class International Racing Association

Severn Sailing Association
Annapolis, MD
June 1-2, 2019

Management and Rules:

- 1.1 Races for competitors in the Snipe class will be conducted under the jurisdiction of the Snipe Class International Racing Association (SCIRA) and under the management of the Race Committee of the Severn Sailing Association. Races shall be conducted in accordance with the following rules: the current Racing Rules of Sailing (RRS) and the prescriptions of US Sailing shall govern except as specifically modified by the SCIRA Constitution and By-laws as published in the current Class Rulebook (including subsequent amendments published in the *Snipe Bulletin* and/or on the official Web site of SCIRA), SCIRA Rules of Conduct For Sanctioned or Club/Fleet Regattas (RoC), the Notice of Race, and these Sailing Instructions.
- 1.2 Advertising on boats shall be governed by ISAF Regulation 20 and the SCIRA Advertising Prescription.

Entry and Eligibility:

- 2.1 SCIRA registered boats and SCIRA Class member skippers may enter by completing registration with Severn Sailing Association. This rule does not apply to Thistle racers.
 - a) Crew membership shall be optional but is strongly encouraged. This modifies ROC 3.
- 2.2 The same crew shall race in all races, except for reasons satisfactory to the Race Committee. Requests for a change of crew shall be submitted in writing to the Principle Race Officer.
- 2.3 Once a skipper and/or crew have been excused, they may not return for the balance of the series.
- 2.4 For competitors in the Snipe class, registration for an Open Division and Silver Division will be available. The SCIRA representative will validate entries registered in each division and reserves the right to modify the entry to reflect which division the entry will be officially scored for purpose of awarding prizes.

Notices to Competitors:

- 3.1 Notices to competitors will be posted on the official regatta notice board located under the deck at the Severn Sailing Association.
- 3.2 Race Committee notices or changes to the Sailing Instructions shall be posted and signaled no later than 30 minutes before the departure of the main Race Committee boat, except any change in the schedule of races will be posted by 20:00 hours on the day before it will take effect.

Competitor's Meeting:

4. There shall be a competitors meeting on the SSA porch, Saturday, June 1, 9:30am.

Signals Made Ashore:

- 5.1 Signals made ashore shall be displayed on the flag pole on the clubhouse deck and announced by sounds per RRS Racing Signals.
- 5.2 Flag "AP" (Alternating red and white Pennant) with two sound signals (one signal when lowered) means the race is postponed. The next signal shall be made not less than 60 minutes after the "AP" is lowered.

Schedule of Races:

Saturday, First Warning Signal 11:00 am (no more than 4 races)
Sunday, First Warning Signal 10:00 am

- 6.1 The Race Committee shall attempt to complete as many as 7 races (the changes the Notice of Race). At the completion of six (6) races there will be one drop. 1 race shall constitute a Regatta.

6.2 No races shall be started after 14:30 hours on Sunday.

Racing Area:

7. The Racing Area is SSA Sailing Area "A". A chart of the sailing area is posted on the Official Notice board.

Courses:

8 The Course shall be posted on a placard on the main committee boat at least one minute prior to the warning signal.

Course options are as follows:

- 8.1 A Windward and Leeward Course, signaled by "W" consisting of windward and leeward legs, twice around, followed by a windward leg and finishing at Mark 1.
- 8.2 A Windward and Leeward Course, signaled by "W2" consisting of windward and leeward legs, twice around, finishing at the main Committee Boat.
- 8.3 An 'Olympic Course', signaled by "O" consisting of a triangle followed by windward, leeward and windward legs and finishing at Mark 1.
- 8.3 A modified 'Olympic Course', signaled by "O2" consisting of a triangle followed by windward, leeward and windward legs and finishing at the main Committee Boat.
- 8.5 A Triangular Course, signaled by "T" consisting of two triangles followed by a windward leg and finishing at Mark 1.
- 8.6 A modified Triangular Course, signaled by "T2" consisting of two triangles followed by a windward leg and finishing at the main Committee Boat.
- 8.7 The approximate compass bearing to Mark 1 shall be displayed by a numerical posting on a board on the Race Committee signal boat before the Preparatory signal.
- 8.8 For the Windward/Leeward courses "W" and "W2", offset marks, and/or leeward gate marks will be employed.
 - a) The race committee may remove any offset mark or one of the marks of the gate without signal prior to the lead boat rounding the adjacent primary or new mark.
- 8.9 The diagrams below show the courses, including the approximate angles between legs, and the order in which marks are to be passed. All course marks (except gates) shall be left to port.

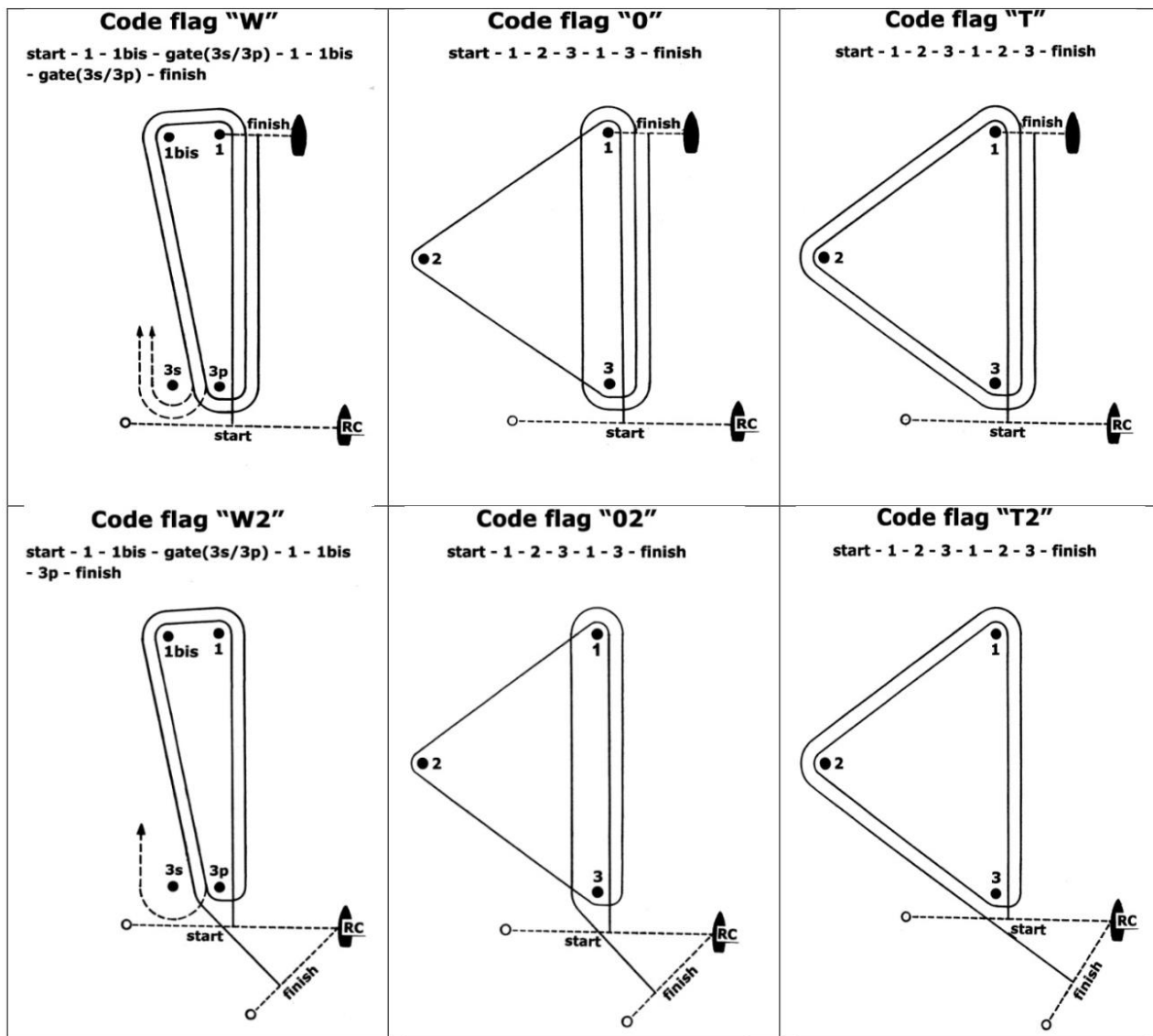

Marks:

- 9.1 Primary marks 1, 2 and 3 shall be orange cylinders.
- 9.2 New marks used in accordance with Change of Course after the Start shall be orange tetrahedrons.
- 9.3 The starting mark shall be a yellow cylinder.
- 9.4 The offset mark shall be an orange cylinder.
- 9.6 For course "W2", "O2", and "T2, the finishing mark shall be an orange sphere

The Start:

- 10.1 Races shall be started in accordance with RRS 26.
- 10.2 The Snipe Open and Silver Divisions will start at the same time.
- 10.3 The starting line shall be between a halyard or staff displaying an orange flag or shape on the Race Committee boat at the starboard end and the course side of the port end starting mark.
- 10.4 A boat shall not start more than 5 minutes after her starting signal. This changes rule A4.

Reporting at Starts:

- 11.1 Each boat shall sail by the race committee signal boat, hail her sail number and be acknowledged by the race committee with a return hail of her sail number. This shall be done before a boat starts the first race in which she competes each day.

- 11.2 A boat failing to comply with the check-in procedure shall receive, without a hearing, a 20% scoring penalty in the first race in which the boat competes, calculated in accordance with RRS 44.3(c). This changes rule 63.1 and A4.

Recalls:

- 12.1 Individual recalls shall be signaled in accordance with RRS 29. An attempt to hail the On Course Side competitors shall be made, but failure to be hailed, the timing of such a hail, or failure to hear a hail is insufficient cause for redress under RRS 62. This changes RRS 62.1(a)
- 12.2 A general recall shall be signaled in accordance with RRS 29.3

Change of Course After the Start:

- 13.1 A change of course shall be made in accordance with RRS 32. The new mark may not be in position at that time.
- 13.2 A triangular lap shall replace a leeward and windward lap if signaled close aboard mark 1 with Flag "T" (red, white and blue vertical stripes), accompanied with a periodic horn or whistle and displaying the approximate numerical compass bearing to the next mark on a board.

The Finish:

- 14.1 The finish line shall be between a halyard or staff displaying an orange flag or shape on a Race Committee boat and the course side of the finishing mark.

Time Limit:

- 15.1 The time limit is 1.5 hours for the first boat to finish.
- 15.2 Any boat finishing more than 20 minutes after the first boat to finish or after the time limit, whichever is later, shall be scored Time Limit Expired (TLE). Competitors must still be racing when the time limit is reached to be scored TLE.

Withdrawing From the Race:

16. A boat which exits the course shall notify the Race Committee at the first reasonable opportunity.

Protests:

- 17.1 A competitor's intent to protest shall be reported to the Race Committee promptly upon finishing that race. This modifies RRS 61.1(a).
- 17.2 Protest forms will be available in the SSA clubhouse and shall be filed with the Race Committee within 1 hour of the official docking time of the RC Signal Boat. Protests shall be filed at the Protest Desk located on the second floor of the SSA clubhouse. The Protest Filing deadline will be posted on the official regatta notice board as soon as possible after the arrival of the RC Signal Boat.
- 17.3 Protest notices and hearing schedules specifying the protester and protestee shall be posted no later than one-half hour after the expiration of the protest filing time limit.

Scoring:

- 18.1 The Low Point Scoring System of RRS Appendix A shall be in effect except that when fewer than six (6) races have been completed, a boat's series score shall be the sum of her individual race scores.
- 18.2 A boat scored TLE (Time Limit Expired) as described in SI 15.2 shall receive points equal to the number of finishers plus one. This changes RRS Appendix A4.2 and A5.
- 18.3 Open and Silver divisions will be scored as one fleet.

Penalties:

19. Any competitor taking a penalty in accordance with RRS 44.1 shall report that use to the Race Committee promptly upon finishing that race.

Team Racing:

20. The use of team racing tactics shall not be tolerated. If the Race Committee (acting under RRS 32(e)) or Protest Committee determines that the use of team racing tactics may have significantly influenced the outcome of a race they shall order that race abandoned and, if possible, re-sailed excluding the participation of the infringing boat(s). This modifies RRS 36. If the race is not re-sailed the infringing boat(s) shall be subject to protest and disqualification.

Disposal of Refuse:

21. The discharge of refuse into the water is prohibited during the entirety of this event. Any boat observed to be in violation is subject to protest and assessment of a 20% penalty for the first race competed in by the infringing boat on the day of the infraction. RRS 60 is changed so that only the Race or Protest Committees may protest under this Sailing Instruction.

Prizes:

- 22.1 The Colonial Cup perpetual trophy will be awarded to top placing skipper/crew regardless of division