

Patio® BISTRO

Small Grill Size, **BIG Grill Features™**



product guide

Propane



Propane cylinder
sold separately

IMPORTANT: Fill out the product record information below.

Serial Number _____
See rating label on unit for serial number.

Date Purchased _____

FOR OUTDOOR USE ONLY

⚠ **CAUTION:**

Read and follow all safety statements, assembly instructions, and use and care directions before attempting to assemble and cook.

INSTALLER/ASSEMBLER:

Leave this manual with consumer.

CONSUMER:

Keep this manual for future reference.

⚠ **WARNING:**

Failure to follow all manufacturer's instructions could result in serious personal injury and/or property damage.

⚠ **CAUTION:**

Some parts may contain sharp edges – especially as noted in the manual! Wear protective gloves if necessary.

If you have questions or need assistance during assembly, please call 1-888-430-7870.

To insure your satisfaction and for follow-up service, register your appliance online at www.charbroil.com/register

The following are trademarks registered by W.C. Bradley Co. in the U.S. Patent and Trademark Office: Caldera®; Charcoal2Go®; Char-Broil®; American Gourmet®; Bandera®; Brush Hawg®; CB 940®; Char-Diamonds®; Char-Broil Charcoal/Gas®; Everybody Grills®; Grill 2 Go®; Grill 2 Go® Express®; Grill Lovers®; Infrared Grilling That's All About U®; Keepers of the Flame®; Magneto®; New Braunfels Smoker Company®; Patio Bistro®; Patio Caddie®; Patio Kitchen®; Pro-Sear®; RED®; Quantum®; Santa Fe®; Sear and Grill®; Sierra®; Signature Series®; Sure2Burn®; The Big Easy®; U®; Wild West Tradition®; and the following marks:



The following are trademarks of W.C. Bradley Co.: America's Legendary Barbeque Company™; Advantage Series™; Auto-Clean™; Chef Tested™; Commercial Series™; Designer Series™; Diamond Flame™; Double Chef™; Everybody Outside™; FastStart™; FlavorMaster™; Front Avenue™; Grill 2 Go® Advantage™; Grill 2 Go® Ice™; Hog and Yard Bird™; H2O Smoker™; Infrared. Grilling's Juicy Little Secret™; Incredible Taste. Infallible Results™; Infrared Inside™; Let's Grill Something Together™; Longhorn™; Precision Flame™; Quick2Burn™; QuickSet™; Ready When You Are™; Season, Set, And Savor™; Sizzle On The Grill™; SureFire™; Torchfork™; Trentino™; Universal Grill Parts™; You Bring the Party™ TEC™ is a trademark of Tec Infrared Grills.

TM Rev.08

TABLE OF CONTENTS



| | |
|--|-------|
| Product Record Information | 1 |
| For Your Safety | 2 |
| Safety Symbols | 2 |
| Installation Safety Precautions. | 3 |
| Food Safety | 3 |
| Use and Care | 4-9 |
| Limited Warranty | 10 |
| Troubleshooting. | 11-13 |
| Registration Card | 15 |



This instruction manual contains important information necessary for the proper assembly and safe use of the appliance. Follow all warnings and instructions when using the appliance.

Safety Symbols



The symbols and boxes shown below explain what each heading means. Read and follow all of the messages found throughout the manual.



| | | |
|---|---------------|---|
|  | DANGER |  |
| DANGER: Indicates an imminently hazardous situation which, if not avoided, will result in death or serious injury. | | |



| | | |
|--|----------------|---|
|  | WARNING |  |
| WARNING: Indicates an potentially hazardous situation which, if not avoided, could result in death or serious injury. | | |



| | | |
|---|----------------|---|
|  | CAUTION |  |
| CAUTION: Indicates a potentially hazardous situation or unsafe practice which, if not avoided, may result in minor or moderate injury. | | |

| | | |
|---|----------------|---|
|  | CAUTION |  |
| For residential use only. Do not use for commercial cooking. | | |

| | | |
|--|---------------|--|
|  | DANGER |  |
| <ol style="list-style-type: none">1. Never operate this appliance unattended.2. Never operate this appliance within 3ft (1m) of any structure, combustible material or other gas cylinder.3. Never operate this appliance within 25 ft (7.5 m) of any flammable liquid.4. If a fire should occur, keep away from the appliance and immediately call your fire department. | | |
| Failure to follow these instructions could result in fire, explosion or burn hazard, which could cause property damage, personal injury or death. | | |



| | | |
|---|---------------|---|
|  | DANGER |  |
| If you smell gas: | | |
| <ol style="list-style-type: none">1. Shut off gas to the appliance.2. Extinguish any open flame.3. Open lid.4. If odor continues, keep away from the appliance and immediately call your gas supplier or your fire department. | | |
| Failure to follow these instructions could result in fire or explosion, which could cause property damage, personal injury or death. | | |

| | | |
|--|----------------|---|
|  | WARNING |  |
| <ol style="list-style-type: none">1. Do not store or use gasoline or other flammable liquids or vapors in the vicinity of this or any other appliance.2. An LP cylinder not connected for use shall not be stored in the vicinity of this or any other appliance. | | |

| | | |
|--|----------------|---|
|  | WARNING |  |
| Do not attempt to repair or alter the hose/valve/regulator for any "assumed" defect. Any modification to this assembly will void your warranty and create the risk of a gas leak and fire. Use only authorized replacement parts supplied by manufacturer. | | |

Installation Safety Precautions

- Use your appliance, as purchased, only with LP (propane) gas and the regulator/valve assembly supplied.
- The appliance installation must conform with local codes, or in their absence of local codes, with either the **National Fuel Gas Code, ANSI Z223.1/ NFPA 54, Natural Gas and Propane Installation Code, CSA B149.1, and Propane Storage and Handling, CSA B149.2, Canadian Electrical Code, CSA C22.1 or the Standard for Recreational Vehicles, ANSI A119.2/NFPA 1192, and CSA Z240 RV Series, Recreational Vehicle Code, as applicable.**
- This appliance is not for use in or on recreational vehicles and/or boats.
- This appliance is safety certified for use in the United States and/or Canada only. Do not modify for use in any other location. Modification will result in a safety hazard.

| | | |
|--|----------------|---|
|  | WARNING |  |
| <p>CALIFORNIA PROPOSITION 65</p> <p>1. Combustible by-products produced when using this product contains chemicals known to the State of California to cause cancer, birth defects, or other reproductive harm.</p> <p>2. This product contains chemicals, including lead and lead compounds, known to the State of California to cause cancer, birth defects or other reproductive harm.</p> <p><u>Wash your hands after handling this product.</u></p> | | |

Storing Your Appliance

- Clean the grill.
- Store in dry location.
- When LP cylinder is connected to appliance, store outdoors in a well-ventilated space and out of reach of children.
- Cover appliance if stored outdoors. Choose from a variety of covers offered by the manufacturer.
- Store indoors ONLY if LP cylinder is turned off and is disconnected, removed from appliance and stored outdoors.
- When removing appliance from storage, follow "Cleaning the Burner Assembly" instructions before starting.

Food Safety

Food safety is a very important part of enjoying the outdoor cooking experience. To keep food safe from harmful bacteria, follow these four basic steps:

Clean: Wash hands, utensils, and surfaces with hot soapy water before and after handling raw meat and poultry.

Separate: Separate raw meats and poultry from ready-to-eat foods to avoid cross contamination. Use a clean platter and utensils when removing cooked foods.

Cook: Cook meat and poultry thoroughly to kill bacteria. Use a thermometer to ensure proper internal food temperatures.

Chill: Refrigerate prepared foods and leftovers promptly.

For more information call: USDA Meat and Poultry Hotline at 1-888-MPHOTLINE (888-674-6854) In Washington, DC

Or E-mail: mph hotline.fsis@usda.gov

Or visit the USDA website at www.fsis.usda.gov

How To Tell If Meat Is Cooked Thoroughly

- Meat and poultry cooked in the appliance often browns very fast on the outside. Use only thawed meat and a meat thermometer to be sure food has reached a safe internal temperature, and cut into food to check for visual signs of doneness.
- We recommend food to be at least 40°F before cooking in your appliance.
- Whole poultry should reach 165° F. Juices should run clear and flesh should not be pink.
- Beef, veal and lamb steaks, roasts and pork chops can be cooked to 160° F.
- NEVER partially cook meat or poultry and finish cooking later. Cook food completely to destroy harmful bacteria.
- Use a meat thermometer to ensure proper internal food temperatures.

| USDA Recommended Internal Cooking Temperatures | |
|---|-------|
| Ground Meat | |
| Beef, Pork, Veal, Lamb..... | 160°F |
| Turkey, Chicken..... | 165°F |
| Fresh Beef, Veal, Lamb | |
| Medium Rare..... | 145°F |
| Medium..... | 160°F |
| Well Done..... | 170°F |
| Poultry | |
| Chicken & Turkey, whole..... | 165°F |
| Poultry Parts..... | 165°F |
| Duck & Goose..... | 165°F |
| Fresh Pork | |
| Medium..... | 160°F |
| Well Done..... | 170°F |

USE AND CARE



DANGER



- **NEVER** store a spare LP cylinder under or near the appliance or in an enclosed area.
- **Never** fill a cylinder beyond 80% full.
- **An over filled or improperly stored cylinder is a hazard due to possible gas release from the safety relief valve. This could cause an intense fire with risk of property damage, serious injury or death.**
- **If you see, smell or hear gas escaping, immediately get away from the LP cylinder/appliance and call your fire department.**

LP Cylinder Removal, Transport and Storage

- Turn OFF the control knob and LP cylinder valve. Turn coupling nut counterclockwise by hand only - do not use tools to disconnect. Install safety cap onto LP cylinder valve. Always use cap and strap supplied with valve. **Failure to use safety cap as directed may result in serious personal injury and/or property damage.**

LP (Liquefied Petroleum Gas)

- LP gas is nontoxic, odorless and colorless when produced. **For Your Safety**, LP gas has been given an odor (similar to rotten cabbage) so that it can be smelled.
- LP gas is highly flammable and may ignite unexpectedly when mixed with air.
- A disconnected LP cylinder in storage or being transported must have a safety cap installed (as shown). Do not store an LP cylinder in enclosed spaces such as a carport, garage, porch, covered patio or other building. Never leave an LP cylinder inside a vehicle which may become overheated by the sun.
- Do not store an LP cylinder in an area where children play.

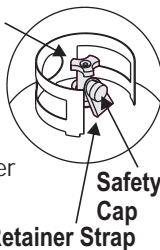

LP Cylinder Filling

- Use only licensed and experienced dealers.
- LP dealer **must purge new cylinder** before filling.
- Dealer should **NEVER** fill LP cylinder more than 80% of LP cylinder volume. Volume of propane in cylinder will vary by temperature.
- A frosty regulator indicates gas overfill. Immediately close LP cylinder valve and call local LP gas dealer for assistance.
- Do not release liquid propane (LP) gas into the atmosphere. This is a hazardous practice.
- To remove gas from LP cylinder, contact an LP dealer or call a local fire department for assistance. Check the telephone directory under "Gas Companies" for nearest certified LP dealers.

LP Cylinder

•The LP cylinder used with your grill must meet the following requirements:

- Use LP cylinders only with these required measurements: 12" (30.5cm) (diameter) x 18" (45.7 cm) (tall) with 20 lb. (9 kg.) capacity maximum.
- LP cylinders must be constructed and marked in accordance with specifications for LP cylinders of the U.S. Department of Transportation (DOT) or for Canada, CAN/CSA-B339, cylinders, spheres and tubes for transportation of dangerous goods. Transport Canada (TC). See LP cylinder collar for marking.
- LP cylinder valve must have:
 - Type 1 outlet compatible with regulator or grill.
 - Safety relief valve.
 - UL listed Overfill Protection Device (OPD). This OPD safety feature is identified by a unique triangular hand wheel. Use only LP cylinders equipped with this type of valve.
- LP cylinder must be arranged for vapor withdrawal and include collar to protect LP cylinder valve. Always keep LP cylinders in upright position during use, transit or storage.

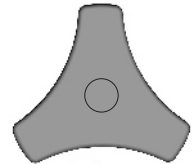

OPD Hand Wheel

LP Cylinder Exchange

- Many retailers that sell this appliance offer you the option of replacing your empty LP cylinder through an exchange service. Use only those reputable exchange companies that inspect, precision fill, test and certify their cylinders. **Exchange your cylinder only for an OPD safety feature-equipped cylinder as described in the "LP Cylinder" section of this manual.**
- Always keep new and exchanged LP cylinders in upright position during use, transit or storage.

• Leak test new and exchanged LP cylinders BEFORE connecting to the appliance.

- Place dust cap on cylinder valve outlet whenever the cylinder is not in use. Only install the type of dust cap on the cylinder valve outlet that is provided with the cylinder valve. Other types of caps or plugs may result in leakage of propane.

LP Cylinder Leak Test

For your safety

- Leak test must be repeated each time LP cylinder is exchanged or refilled.
- Do not smoke during leak test.
- Do not use an open flame to check for gas leaks.
- This appliance must be leak tested outdoors in a well-ventilated area, away from ignition sources such as gas fired or electrical appliances. During leak test, keep appliance away from open flames or sparks.
- Use a clean paintbrush and a 50/50 mild soap and water solution. Brush soapy solution onto areas indicated by arrows in figure below.
- **Do not use household cleaning agents.** Damage to gas train components can result.

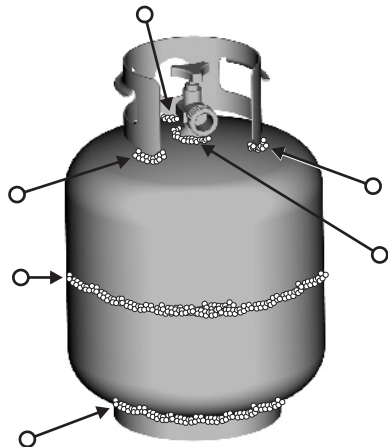

| | | |
|---|----------------|--|
| | WARNING | |
| If "growing" bubbles appear do not use or move the LP cylinder. Contact an LP gas supplier or your fire department! | | |

Connecting Regulator to the LP Cylinder

1. LP cylinder must be properly secured onto appliance. (Refer to assembly section.)
2. Turn all control knobs to the OFF position.
3. Turn LP cylinder OFF by turning hand-wheel clockwise to a **full stop**.
4. Remove the protective cap from LP cylinder valve. Always use cap and strap supplied with valve.

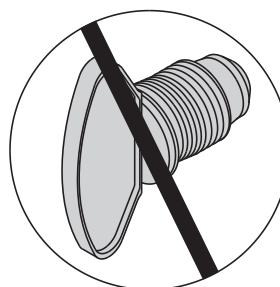
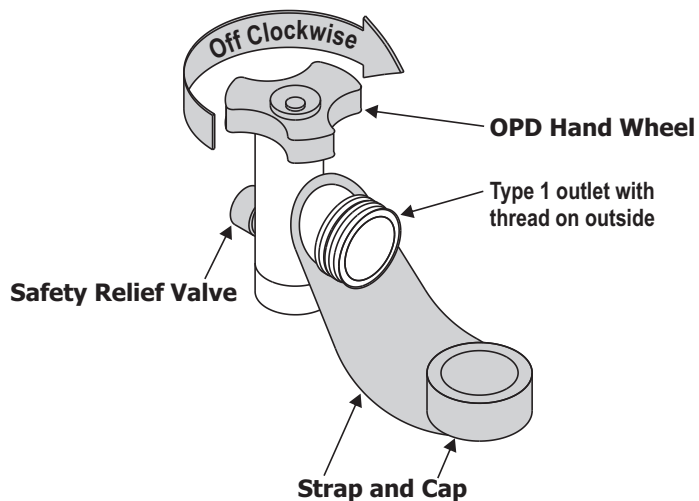

Do not use a POL transport plug (plastic part with external threads)! It will defeat the safety feature of the valve.

5. Hold regulator and insert nipple into LP cylinder valve. Hand-tighten the coupling nut, holding regulator in a straight line with LP cylinder valve so as not to cross-thread the connection.

Nipple has to be centered into the LP cylinder valve.

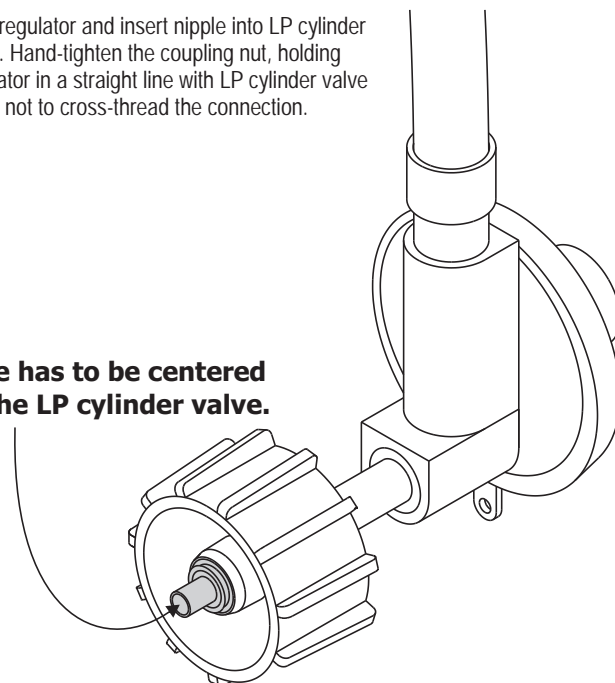

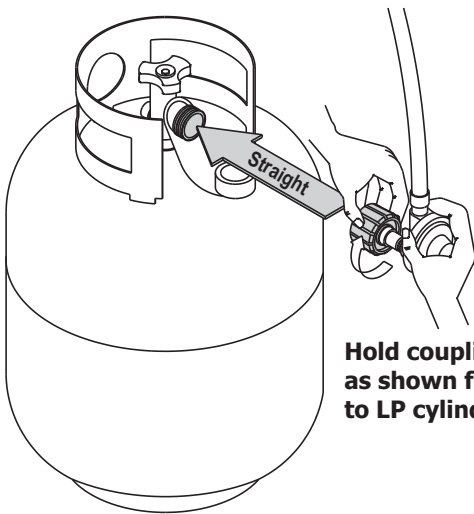

Hold coupling nut and regulator as shown for proper connection to LP cylinder valve.

6. Turn the coupling nut clockwise and tighten to a full stop. The regulator will seal on the back-check feature in the LP cylinder valve, resulting in some resistance. **An additional one-half to three-quarters turn is required to complete the connection. Tighten by hand only – do not use tools.**

NOTE:

If you cannot complete the connection, disconnect regulator and repeat steps 5 and 6. If you are still unable to complete the connection, **do not use this regulator!**

| | | |
|--|---------------|--|
| | DANGER | |
| <ul style="list-style-type: none"> Do not insert any tool or foreign object into the valve outlet or safety relief valve. You may damage the valve and cause a leak. Leaking propane may result in explosion, fire, severe personal injury, or death. | | |

| | | |
|--|----------------|--|
| | WARNING | |
| <ul style="list-style-type: none"> This appliance is not intended to be installed in or on a boat. This appliance is not intended to be installed in or on an RV. Never attempt to attach this appliance to the self-contained LP gas system of a camper trailer or motor home. Do not use this appliance until leak-tested. If a leak is detected at any time, STOP and call the fire department. If you cannot stop a gas leak, <i>immediately</i> close LP cylinder valve and call LP gas supplier or your fire department! | | |

Leak Testing Valves, Hose and Regulator

- 1. Turn control knob to OFF.**
- Be sure regulator is tightly connected to LP cylinder.
- Completely open LP cylinder valve by turning hand wheel counterclockwise. If you hear a rushing sound, turn gas off immediately. There is a major leak at the connection. **Correct before proceeding.**
- Brush soapy solution onto areas circled below.

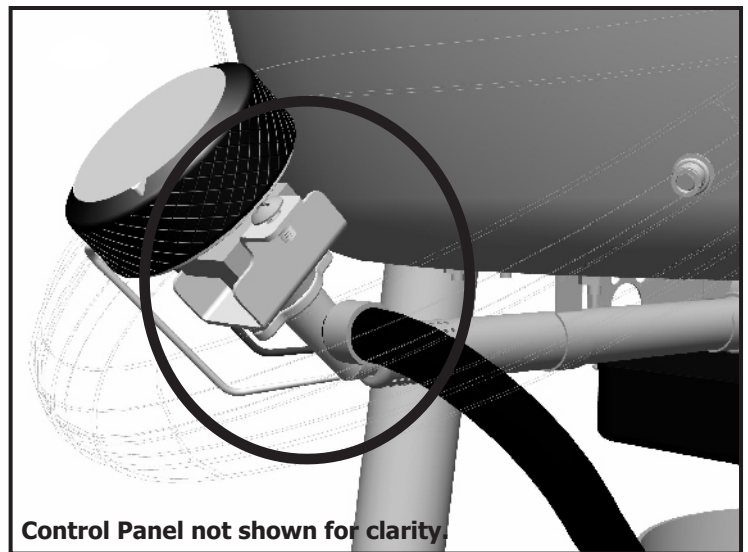

- 5. If "growing" bubbles appear, there is a leak.** Close LP cylinder valve immediately and retighten connections. **If leaks cannot be stopped do not try to repair.** Call for replacement parts. Order new parts by giving the serial, model number and name and part number of items needed (see parts list) to the Grill Service Center at the number listed on front cover.
- 6.** Always close LP cylinder valve after performing leak test by turning hand wheel clockwise.



WARNING



For Safe Use of Your appliance and to Avoid Serious Injury:

- The use of alcohol, prescription or non-prescription drugs may impair the consumer's ability to properly assemble or safely operate the appliance.
- When cooking, the appliance must be on a level, stable noncombustible surface in an area clear of combustible material. An asphalt surface (blacktop) may not be acceptable for this purpose.
- Do not leave appliance unattended. Keep children and pets away from the appliance at all times.
- Do not place empty cooking vessel on the appliance while in operation. Use caution when placing anything in cooking vessel while the appliance is in operation.
- Do not move the appliance when in use. Allow the cooking vessel to cool to 115°F (45°C) before moving or storing.
- This appliance is not intended for and should never be used as a heater.
- This appliance will be hot during and after use. Use insulated oven mitts or gloves and long-handled barbecue utensils for protection from hot surfaces or splatter from cooking liquids.
- Keep appliance area clear and free from materials that burn.
- Keep appliance area clear and free from combustible materials, gasoline and other flammable vapors and liquids.
- Keep fuel supply hose away from any heated surfaces.
- Use appliance only in well-ventilated space. NEVER use in enclosed space such as carport, garage, porch, covered patio, or under an overhead structure of any kind.
- **Use appliance at least 3 ft. from any wall or surface.** Maintain 10 ft. clearance to objects that can catch fire or sources of ignition such as pilot lights on water heaters, live electrical appliances, etc.

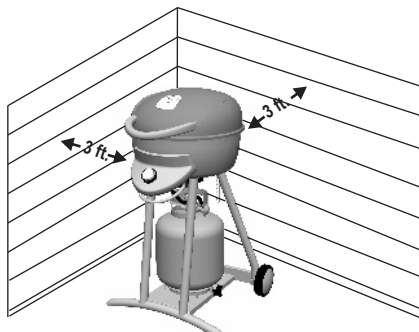

• Apartment Dwellers:

Check with management to learn the requirements and fire codes for using an LP gas appliance in your apartment complex. If allowed, use outside on the ground floor with a three (3) foot clearance from walls or rails. Do not use on or under balconies.

- **NEVER attempt to light burner with any type of closed cover . A buildup of non-ignited gas inside a closed appliance is hazardous.**
- **Never operate appliance with LP cylinder out of correct position specified in assembly instructions.**
- **Always close LP cylinder valve and remove coupling nut before moving LP cylinder from specified operation position.**

Safety Tips

- Before opening LP cylinder valve, check the coupling nut for tightness.
- When this appliance is not in use, turn off control knob and LP cylinder valve.
- The grease tray **must** be inserted into appliance and emptied after each use.
- If you notice grease or other hot material dripping from appliance onto valve, hose or regulator, turn off gas supply at once. Determine the cause, correct it, then clean and inspect valve, hose and regulator before continuing. Perform a leak test.
- Do not store objects or materials under the appliance enclosure that would block the flow of combustion air to the underside of either the control panel or the firebox bowl.
- The regulator may make a humming or whistling noise during operation. This will not affect safety or use of the appliance.
- If you have an appliance problem see the "Troubleshooting Section".
- If the regulator frosts, turn off appliance and LP cylinder valve immediately. This indicates a problem with the cylinder and it should not be used on any product. Return to supplier!
- Clean grill often, preferably after each cookout. If a bristle brush is used to clean any of the grill cooking surfaces, ensure no loose bristles remain on cooking surfaces prior to grilling. It is not recommended to clean cooking surfaces while grill is hot.



CAUTION



- **Putting out grease fires by closing the lid is not possible. This appliance is well ventilated for safety reasons.**
- **Do not use water on a grease fire. Personal injury may result. If a grease fire develops, turn knobs and LP cylinder off.**
- **Do not leave appliance unattended while burning off food residue. If appliance has not been regularly cleaned, a grease fire can occur that may damage the product.**

Ignitor Lighting



READ INSTRUCTIONS BEFORE LIGHTING.

Do NOT lean over appliance while lighting.

1. Turn **OFF** gas burner control valve.
2. Turn **ON** gas at LP gas cylinder.
3. **Open** the grill lid.
4. Press and turn the control knob to the **Ignition** ⚡ position.
5. Once the burner has ignited, turn the control knob to the desired setting.
6. If ignition does not occur in 5 seconds, turn the burner control knob OFF, wait 5 minutes, and repeat lighting procedure.

If ignition still does not occur, follow match-lighting instructions.

| | | |
|---|----------------|---|
|  | WARNING |  |
| Turn control knob and LP cylinder OFF when not in use. | | |

| | | |
|---|----------------|---|
|  | CAUTION |  |
| If ignition does NOT occur in 5 seconds, turn the control knob OFF, wait 5 minutes and repeat the lighting procedure. If the burner does not ignite with the valve open, gas will continue to flow out of the burner and could accidentally ignite with risk of injury. | | |

Match-Lighting

Do NOT lean over appliance while lighting.

1. Turn **OFF** gas burner control valve.
2. Turn **ON** gas at LP cylinder.
3. Open grill lid.
4. Insert match into match holder. Strike match. Place lit match into match light hole at the rear of the grill bottom, shown "A". Make sure lit match is placed inside through the hole and near burner.
5. Push in and turn control knob to position ⑤. Be sure burner lights and stays lit.

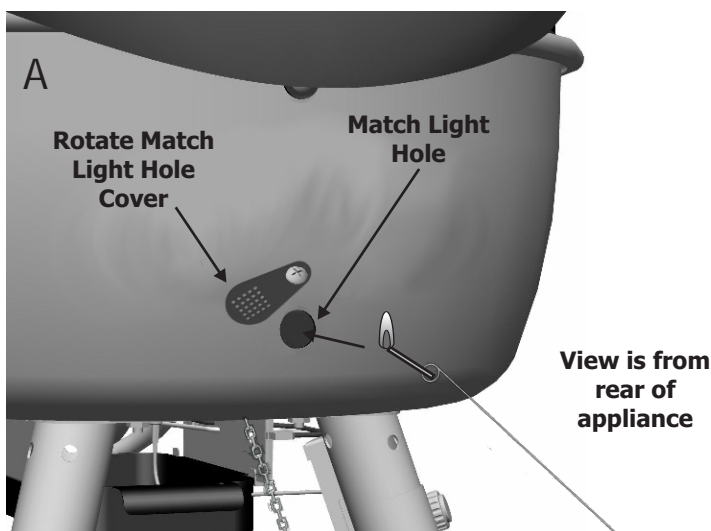

Burner Flame Check

- Light burner. Looking through the match light hole underneath the appliance, you should see the flame height as shown below. Turn control knob from position ⑤ to ①. The flame height should decrease. Always check flame prior to each use. If only low flame is seen refer to "Sudden drop or low flame" in the Troubleshooting Section.

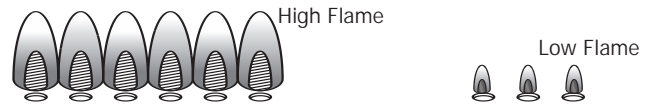

Turning Appliance Off

- Turn control knob to **OFF** position. Turn LP cylinder **OFF** by turning hand-wheel clockwise to a full stop.

Ignitor Check

- **Turn gas OFF at LP cylinder.** Turn ignitor knob. "Click" should be heard each time at electrode. See "Troubleshooting" if no click or spark.

Valve Check

- **Important: Make sure gas is off at LP cylinder before checking valve.** Knob locks in **OFF** position. To check valve, first push in knob and release, knob should spring back. If knob does not spring back, replace valve assembly before using this appliance. Turn knob to position ① then turn back to **OFF** position. Valve should turn smoothly.

Hose Check

- Before each use, check to see if hose is cut, worn or kinked. Replace damaged hose before using appliance. **Use only valve/hose/regulator specified by manufacturer.**



General Appliance Cleaning

- **Meat Thermometer:** Do not immerse or soak in water. Wash with warm soapy water and wipe dry.
- Do not mistake brown or black accumulation of grease and smoke for paint. Interiors are not painted at the factory (**and should never be painted**). Apply a strong solution of detergent and water or use a grill cleaner with scrub brush on insides of appliance lid and bottom. Rinse and allow to completely air dry. **Do not apply a caustic grill/oven cleaner to painted surfaces.** A black surface improves the appliances performance.
- **Plastic parts:** Wash with warm soapy water and wipe dry. Do not use citrisol, abrasive cleaners, degreasers or a concentrated grill cleaner on plastic parts. Damage to and failure of parts can result.
- **Painted surfaces:** Wash with mild detergent or non-abrasive cleaner and warm soapy water. Wipe dry with a soft non-abrasive cloth.
- **Cooking surfaces:** If a bristle brush is used to clean any of the grill cooking surfaces, ensure no loose bristles remain on cooking surfaces prior to grilling. It is not recommended to clean cooking surfaces while grill is hot.



CAUTION

SPIDER ALERT!

SPIDER AND WEBS
INSIDE BURNER

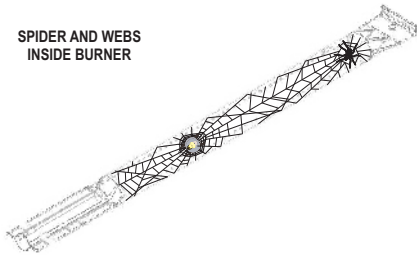

If you notice that your the appliance is getting hard to light or that the flame isn't as strong as it should be, take the time to check and clean the venturi's.

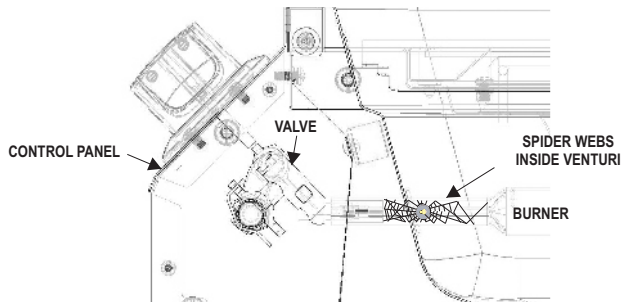

In some areas of the country, spiders or small insects have been known to create "flashback" problems. The spiders spin webs, build nests and lay eggs in the the appliance's venturi tube(s) obstructing the flow of gas to the burner. The backed-up gas can ignite in the venturi behind the control panel. This is known as a flashback and it can damage your the appliance and even cause injury.

To prevent flashbacks and ensure good performance the burner and venturi assembly should be removed from the the appliance and cleaned before use whenever the the appliance has been idle for an extended period.

Cleaning the Burner Assembly

Follow these instructions to clean and/or replace parts of burner assembly or if you have trouble igniting appliance.

1. **Turn gas OFF at control knob and LP cylinder and disengage regulator from cylinder.**
2. Remove grease tray. Open top cover, remove cooking grate, heat tent and warming rack, shown **A**. This will expose the burner from inside, shown **B**.
3. Working from underneath the appliance, remove 2 nuts securing the burner to the bottom, shown **C**
4. From the top of the grill, carefully lift burner out, shown **D**.
5. Clean any blocked ports with a stiff wire such as an open paper clip.

Cleaning the Burner Assembly (Continued)

6. Clean burner as recommended below, shown **E**. We suggest three ways to clean the burner tube. Use the one easiest for you.

- (A) Bend a stiff wire (a light weight coat hanger works well) into a small hook. Run hook through burner tube several times.



- (B) Use a narrow bottle brush with a flexible handle (do not use a brass wire brush), run the brush through burner tube several times.

- (C) **Wear eye protection:** Use an air hose to force air into the burner tube and out the burner ports. Check each port to make sure air comes out each hole.

7. Check burner for damage, due to normal wear and corrosion some holes may become enlarged. If any large cracks or holes are found replace burner.

8. Insert burner into firebox .

VERY IMPORTANT: Burner tube must re-engage over valve opening. See illustration, shown F.

9. Reattach burner bracket nuts

10. Reinstall heat tent, cooking grates and warming rack.

Ensure Cooking Grate ridges run front to back (fig.A)

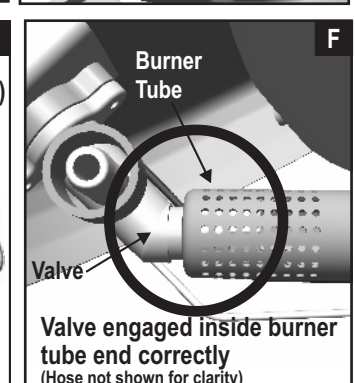
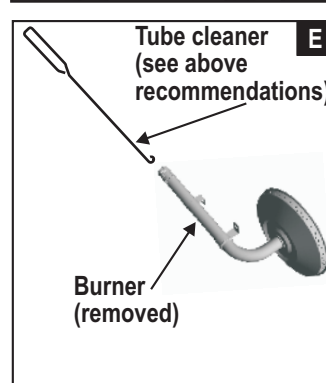
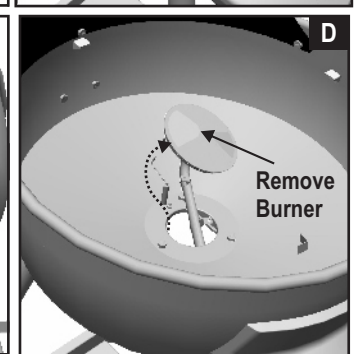
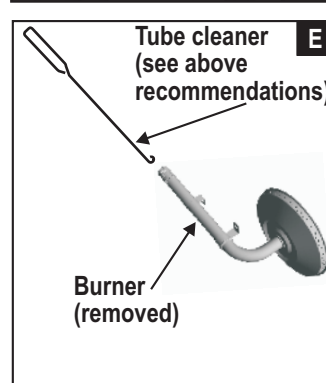
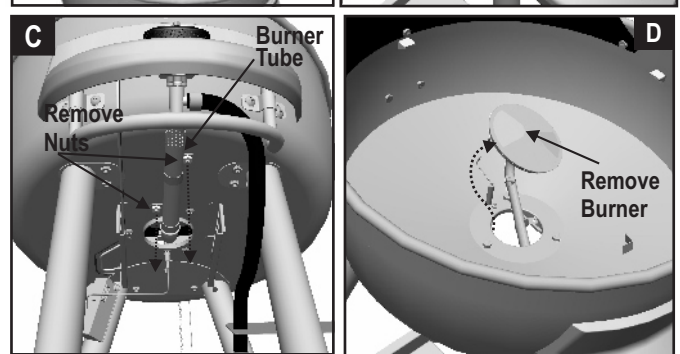
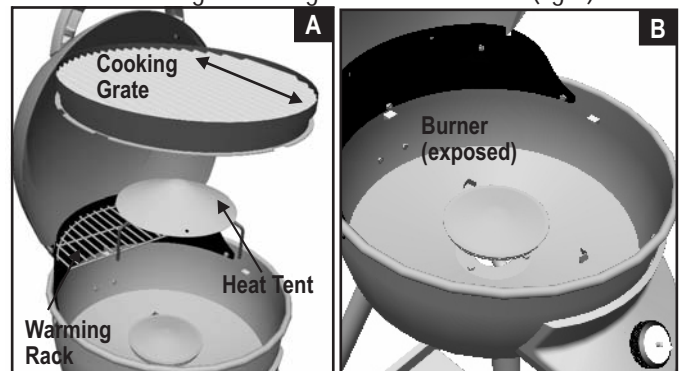

LIMITED WARRANTY

This warranty only applies to units purchased from an authorized retailer. Manufacturer warrants to the **original consumer-purchaser** only that this product shall be free from defects in workmanship and materials after correct assembly and under normal and reasonable home use for the periods indicated below beginning on the date of purchase*. The manufacturer reserves the right to require that defective parts be returned, postage and or freight pre-paid by the consumer for review and examination.

| <u>SCOPE OF COVERAGE</u> | <u>PERIOD OF COVERAGE</u> | <u>TYPE OF FAILURE COVERAGE</u> |
|--------------------------|--------------------------------|---|
| All Parts | 90 days from date of purchase* | PERFORATION, MANUFACTURING, AND MATERIAL DEFECTS ONLY |
| | | |

*Note: A dated sales receipt WILL be required for warranty service.

The original consumer-purchaser will be responsible for all shipping charges for parts replaced under the terms of this limited warranty.

This limited warranty is applicable in the United States and Canada only, is only available to the original owner of the product and is not transferable. **Manufacturer requires proof of your date of purchase. Therefore, you should retain your sales slip or invoice.** Registering your product is not a substitute for proof of purchase and the manufacturer is not responsible for or required to retain proof of purchase records.

This limited warranty applies to the functionality of the product ONLY and does not cover cosmetic issues such as scratches, dents, corrossions or discoloring by heat, abrasive and chemical cleaners or any tools used in the assembly or installation of the appliance, surface rust, or the discoloration of stainless steel surfaces. **RUST is not considered a manufacturing or materials defect.**

This limited warranty will not reimburse you for the cost of any inconvenience, food, personal injury or property damage.

ITEMS MANUFACTURER WILL NOT PAY FOR:

1. Shipping cost, standard or expedited, for warranty and replacement parts
2. Service calls to your home.
3. Repairs when your product is used for other than normal, single-family household or residential use.
4. Damage, failures, or operating difficulties resulting from accident, alteration, careless handling, misuse, abuse, fire, flood, acts of God, improper installation or maintenance, installation not in accordance with electrical or plumbing codes, or use of products not approved by the manufacturer.
5. Any food loss due to product failures or operating difficulties.
6. Replacement parts or repair labor costs for units operated outside the United States or Canada.
7. Pickup and delivery of your product.
8. Repairs to parts or systems resulting from unauthorized modifications made to the product.
9. The removal and/or reinstallation of your product.

DISCLAIMER OF IMPLIED WARRANTIES and LIMITATION OF REMEDIES

Repair or replacement of defective parts is your exclusive remedy under the terms of this limited warranty. In the event of parts availability issues, the manufacturer reserves the right to substitute like or similar parts that are equally functional.

Manufacturer will not be responsible for any consequential or incidental damages arising from the breach of either this limited warranty or any applicable implied warranty, or for failure or damage resulting from acts of God, improper care and maintenance, grease fire, accident, alteration, replacement of parts by anyone other than Manufacturer, misuse, transportation, commercial use, abuse, hostile environments (inclement weather, acts of nature, animal tampering), improper installation or installation not in accordance with local codes or printed manufacturer instructions.

THIS LIMITED WARRANTY IS THE SOLE EXPRESS WARRANTY GIVEN BY THE MANUFACTURER. NO PRODUCT PERFORMANCE SPECIFICATION OR DESCRIPTION WHEREVER APPEARING IS WARRANTED BY MANUFACTURER EXCEPT TO THE EXTENT SET FORTH IN THIS LIMITED WARRANTY. ANY IMPLIED WARRANTY PROTECTION ARISING UNDER THE LAWS OF ANY STATE, INCLUDING IMPLIED WARRANTY OF MERCHANTABILITY OR FITNESS FOR A PARTICULAR PURPOSE OR USE, IS HEREBY LIMITED IN DURATION TO THE DURATION OF THIS LIMITED WARRANTY.

Neither dealers nor the retail establishment selling this product has any authority to make any additional warranties or to promise remedies in addition to or inconsistent with those stated above. Manufacturer's **maximum liability**, in any event, shall not exceed the purchase price of the product paid by the original consumer.

NOTE: Some states do not allow an exclusion or limitation of incidental or consequential damages, so some of the above limitations or exclusions may not apply to you. This limited warranty gives you specific legal rights as set forth herein. You may also have other rights which vary from state to state. In the state of California only, if refinishing or replacement of the product is not commercially practicable, the retailer selling this product or the Manufacturer will refund the purchase price paid for the product, less the amount directly attributable to use by the original consumer-purchaser prior to discovery of the nonconformity. In addition, in the state of California only, you may take the product to the retail establishment selling this product in order to obtain performance under this limited warranty.

If you wish to obtain performance of any obligation under this limited warranty, you should write to:

**Consumer Relations
P. O. Box 1240
Columbus, GA 31902-1240**

Consumer returns will not be accepted unless a valid Return Authorization is first acquired. Authorized returns are clearly marked on the outside of the package with an RA number and the package is shipped freight/postage pre-paid. Consumer returns that do not meet these standards will be refused.

EMERGENCIES: If a gas leak cannot be stopped, or a fire occurs due to gas leakage, call the fire department.

| Emergencies | Possible Cause | Prevention/Solution |
|---|--|---|
| Gas leaking from cracked/cut/burned hose. | • Damaged hose. | • Turn off gas at LP cylinder or at source on natural gas systems. If anything but burned, replace valve/hose/regulator. If burned, discontinue use of product until a plumber has investigated cause and corrections are made. |
| Gas leaking from LP cylinder. | • Mechanical failure due to rusting or mishandling. | • Replace LP cylinder. |
| Gas leaking from LP cylinder valve. | • Failure of cylinder valve from mishandling or mechanical failure. | • Turn off LP cylinder valve. Return LP cylinder to gas supplier. |
| Gas leaking between LP cylinder and regulator connection. | • Improper installation, connection not tight, failure of rubber seal. | • Turn off LP cylinder valve. Remove regulator from cylinder and visually inspect rubber seal for damage. See LP Cylinder Leak Test and Connecting Regulator to the LP Cylinder. |
| Fire coming through control panel. | • Fire in burner tube section of burner due to blockage. | • Turn off control knobs and LP cylinder valve. Leave lid open to allow flames to die down. After fire is out and grill is cold, remove burner and inspect for spider nests or rust. See Natural Hazard and Cleaning the Burner Assembly pages. |
| Grease fire or continuous excessive flames above cooking surface. | • Too much grease buildup in burner area. | • Turn off control knobs and LP cylinder valve. Leave lid open to allow flames to die down. After cooling, clean food particles and excess grease from inside firebox area, grease tray, and other surfaces. |

Troubleshooting



| Problem | Possible Cause | Prevention/Solution |
|---|--|---|
| <p>Burner(s) will not light using ignitor. (See Electronic Ignition Troubleshooting also)</p> <p><i>Continued on next page.</i></p> | <p>GAS ISSUES:</p> <ul style="list-style-type: none"> • Trying to light wrong burner. • Burner not engaged with control valve. • Obstruction in burner. • No gas flow. • Vapor lock at coupling nut to LP cylinder. • Coupling nut and LP cylinder valve not fully connected. <p>ELECTRICAL ISSUES:</p> <ul style="list-style-type: none"> • Electrode cracked or broken; "sparks at crack." • Electrode tip not in proper position. • Wire and/or electrode covered with cooking residue. • Wires are loose or disconnected. • Wires are shorting (sparking) between ignitor and electrode. • Dead battery. | <ul style="list-style-type: none"> • See instructions on control panel and in Use and Care section. • Make sure valves are positioned inside of burner tubes. • Ensure burner tubes are not obstructed with spider webs or other matter. See cleaning section of Use and Care. • Make sure LP cylinder is not empty. If LP cylinder is not empty, refer to "Sudden drop in gas flow." • Turn off knobs and disconnect coupling nut from LP cylinder. Reconnect and retry. • Turn the coupling nut approximately one-half to three-quarters additional turn until solid stop. Tighten by hand only - do not use tools. • Replace electrode(s). <p>Main Burners:</p> <ul style="list-style-type: none"> • Tip of electrode should be pointing toward gas port opening on burner. The distance should be 1/8" to 1/4". Adjust if necessary. <p>Sideburner:</p> <ul style="list-style-type: none"> • Tip of electrode should be pointing toward gas port opening on burner. The distance should be 1/8" to 3/16". Adjust if necessary. <ul style="list-style-type: none"> • Clean wire and/or electrode with rubbing alcohol and clean swab. • Reconnect wires or replace electrode/wire assembly. • Replace ignitor wire/electrode assembly. • Replace with a new AA-size alkaline battery. |

REV01

Troubleshooting (continued)

| Problem | Possible Cause | Prevention/Solution |
|---|--|---|
| Burner(s) will not light using ignitor. | <ul style="list-style-type: none"> Faulty electronic ignition circuit. Sparking somewhere other than between burner and electrode. | <ul style="list-style-type: none"> See Troubleshooting Integrated Electronic Ignition section. Inspect wire insulation and proper connections. Replace wires if insulation is broken. |
| Burner(s) will not match light. | <ul style="list-style-type: none"> See "GAS ISSUES:" on previous page. Improper method of match-lighting. | <ul style="list-style-type: none"> See "Match-Lighting" section of Use and Care. |
| Sudden drop in gas flow or low flame. | <ul style="list-style-type: none"> Out of gas. Excess flow valve tripped. Vapor lock at coupling nut/LP tank connection. | <ul style="list-style-type: none"> Check for gas in LP tank. Turn off knobs, wait 30 seconds and light grill. If flames are still low, turn off knobs and LP tank valve. Disconnect regulator. Reconnect regulator and leak-test. Turn on LP tank valve, wait 30 seconds and then light grill. Turn off knobs and LP tank valve. Disconnect coupling nut from tank. Reconnect and retry. |
| Flames blow out. | <ul style="list-style-type: none"> High or gusting winds. Low on LP gas. Excess flow valve tripped. | <ul style="list-style-type: none"> Turn front of grill to face wind or increase flame height. Refill LP tank. Refer to "Sudden drop in gas flow" above. |
| Flare-up. | <ul style="list-style-type: none"> Grease buildup. Excessive fat in meat. Excessive cooking temperature. | <ul style="list-style-type: none"> Clean burners and inside of grill/firebox. Trim fat from meat before grilling. Adjust (lower) temperature accordingly. |
| Persistent grease fire. | <ul style="list-style-type: none"> Grease trapped by food buildup around burner system. | <ul style="list-style-type: none"> Turn knobs to OFF. Turn gas off at LP tank. Leave lid in position and let fire burn out. After grill cools, remove and clean all parts. |
| Flashback... (fire in burner tube(s)). | <ul style="list-style-type: none"> Burner and/or burner tubes are blocked. | <ul style="list-style-type: none"> Turn knobs to OFF. Clean burner and/or burner tubes. See burner cleaning section of Use and Care manual. |
| Unable to fill LP tank. | <ul style="list-style-type: none"> Some dealers have older fill nozzles with worn threads. | <ul style="list-style-type: none"> The worn nozzles don't have enough "bite" to engage the valve. Try a second LP dealer. |
| One burner does not light from other burner(s). | <ul style="list-style-type: none"> Grease buildup or food particles in end(s) of carryover tube(s). | <ul style="list-style-type: none"> Clean carry-over tube(s) with wire brush. |

Troubleshooting - Integrated Electronic Ignition

| Problem (Ignition) | Possible Cause | Check Procedure | Prevention/Solution |
|--|--|--|---|
| <p>SECTION I No sparks appear at any electrodes when burner control knobs are turned to ; no noise can be heard from spark module.</p> | <ul style="list-style-type: none"> •Battery not installed properly. •Dead battery. •Battery cap not installed properly. •Faulty spark module. | <ul style="list-style-type: none"> •Check battery orientation. •Has battery been used previously? •Check to ensure battery cap is fully engaged. •If no sparks are generated with new battery and good wire connections, module is faulty. | <ul style="list-style-type: none"> •Install battery (make sure that "+" and "-" connectors are oriented correctly, with "+" end up and "-" end down.) •Replace battery with new AA-size alkaline battery. •Remove battery cap and reinstall, making sure it can be fully engaged. •Replace spark module assembly. |
| <p>SECTION II No sparks appear at any electrodes when burner control knobs are turned to ; noise can be heard from spark module.</p> | <ul style="list-style-type: none"> •Output lead connections not connected. •Electrode tip not in proper position. | <ul style="list-style-type: none"> •Are output connections on and tight? •Are the electrode tips pointing in the right direction? Is the gap too big? | <ul style="list-style-type: none"> •Remove and reconnect all output connections at module and electrodes. <p>Main Burners: •Tip of electrode should be pointing toward port hole in burner. The distance should be 1/8" to 3/16". Adjust if necessary.</p> <p>Sideburner: •Tip of electrode should be pointing toward gas port opening on burner. The distance should be 1/8" to 3/16". Adjust if necessary.</p> |
| <p>SECTION III Sparks are present but not at all electrodes and/or not at full strength</p> | <ul style="list-style-type: none"> •Output lead connections not connected. •Arcing to grill away from burner(s). •Weak battery. •Electrodes are wet. •Electrodes cracked or broken "sparks at crack". | <ul style="list-style-type: none"> •Are output connections on and tight? •If possible, observe grill in dark location. Operate ignition system and look for arcing between output wires and grill frame. •All sparks present but weak or at slow rate. •Has moisture accumulated on electrode and/or in burner ports? •Inspect electrodes for cracks. | <ul style="list-style-type: none"> •Remove and reconnect all output connections at module and electrodes. •If sparks are observed other than from burner(s), wire insulation may be damaged. Replace wires. •Replace battery with a new AA-size alkaline battery. •Use paper towel to remove moisture. •Replace cracked or broken electrodes. |

Please register your product online at:

www.charbroil.com/register

(If you register online, you do not need to send in this registration card.)

PLEASE FILL OUT THIS CARD AND ATTACH A COPY OF YOUR SALES RECEIPT. RETURN IT WITHIN 10 DAYS OF PURCHASE. FAILURE TO RETURN MAY AFFECT YOUR WARRANTY COVERAGE. FOR WARRANTY SERVICE PROOF OF PURCHASE WILL BE REQUIRED. THIS WARRANTY IS NON-TRANSFERABLE.

LENE ESTA TARJETA Y DEVUELVALA DENTRO DE LOS 10 DIAS DE LA COMPRA. SI NO LA DEVUELVE, PUEDE VERSE AFECTADA SU COBERTURA DE GARANTIA. PARA EL SERVICIO DE GARANTIA ES NECESARIO QUE PRESENTE SU COMPROBANTE DE COMPRA. CONSERVE LA FACTURA. ESTA GARANTIA ES INTRANSFERIBLE.

VEUILLEZ COMPLETER CETTE CARTE ET LA RETOURNER DANS LES 10 JOURS SUIVANT L'ACHAT. LA COUVERTURE DE VOTRE GARANTIE POURRAIT EN ETRE AFFECTEE SI VOUS NE LE FAITES PAS. POUR OBTENIR LE SERVICE SOUS GARANTIE, UNE PREUVE D'ACHAT DOIT ETRE PRESENTEE. VEUILLEZ CONSERVER VOTRE FACTURE. LA PRESENTE GARANTIE N'EST PAS TRANSFERABLE.

1 First Name/Nombre/Prénom Initial/Inicial/Initiale Last Name/Apellido/Nom de famille

Address (number and street)/Dirección (número y calle)/Adresse (numéro et rue) Apt Number/Nº de apart./Nº d'appt.

City/Ciudad/Ville State/Estado/Province Zip Code/Código Zip/Code postal

2 E-mail Address/Dirección de correo electrónico/Adresse électronique

If you voluntarily provide us with your email address, you give us permission to use your email address to send you offers that may interest you.

Si nos informa voluntariamente su dirección de correo electrónico, nos da permiso para usarlo a fin de enviarle ofertas que pueden interesarle.

Si vous choisissez de nous fournir votre adresse électronique, vous nous donnez la permission de l'utiliser pour vous faire part d'offres spéciales susceptibles de vous intéresser.

(Example: your name @ your host.com) (Ejemplo: su nombre@su host.com) (Exemple : votre nom@votre hôte.com)

10 Attach copy of your sales receipt here

Adjunte aquí la copia de su recibo de compra
Veillez attacher une copie de votre reçu ici.

3 Phone Number/Número telefónico/Numéro de téléphone

6 Date of Purchase/Fecha de compra/Date de l'achat

4 **IMPORTANT! ¡IMPORTANTE! IMPORTANT!**
Write Serial Number and Model Number in spaces below.
Escriba en los espacios de abajo el número de serie y el número de modelo.
Inscrivez le numéro de série et le numéro de modèle dans les espaces ci-dessous.

7 Store Name/Nombre de la tienda/Nom du magasin

8 Purchase Price/Precio de compra/Prix d'achat

\$ _____ .00

5 Your Gender/Sexo/Sexe :

1. Male/Masculino/Masculin

2. Female/Femenino/Féminin

9 Which product are you registering?

¿Qué producto está registrando?

Quel produit enregistrez-vous?

1. Gas Grill/Parrilla a gas/Gril au gaz
2. Electric Grill/Parrilla eléctrica/Gril électrique
3. Smoker/Ahumador/Fumoir
4. Charcoal Grill/Parrilla a carbón/Barbecue au charbon
5. Charcoal Smoker/Ahumador a carbón/Fumoir au charbon
6. Outdoor Fireplace/Chimenea para exteriores/Foyer extérieur
7. Cooker/Fryer / Cocina/freidora / Cuiseur/Friteuse
8. Other/Otro/Autre

Mail to: / Envíelo a:

**Warranty Registration Department
P.O. Box 1240
Columbus, Ga 31902-1240**

Thank you for completing this questionnaire. Your answers will help us and other companies reach you with offers that may interest you. If you prefer not to receive these offers, please check here

Gracias por completar este cuestionario. Sus respuestas nos ayudarán, a nosotros y a otras compañías, a llegar a usted con ofertas que puedan resultarle de interés. Si prefiere no recibir estas ofertas, por favor marque aquí .

Merci d'avoir bien voulu remplir ce questionnaire. Vos réponses nous aideront et aideront d'autres compagnies à vous communiquer des offres spéciales susceptibles de vous intéresser. Si vous préférez ne pas recevoir d'informations concernant ces offres spéciales, veuillez cocher ici .

REGTEMP REV02



Here's what you can find at
www.charbroil.com

- Register your Char-Broil® product
- Get information about our products
- Our replacement parts
- Reliable customer support
- Delicious recipes
- Char-Broil® on-line store
- *Sizzle On The Grill*™ E-newsletter
- And much more!



Please visit us at **www.charbroil.com** and click on the *Buy Online* link to find grilling tools and accessories, maintenance items, covers, grill parts, as well as Char-Broil® grills and cookers. We also have a *Special Offers* section, so be sure to check often for specials deals.



In addition to the online store, charbroil.com offers you a wealth of information regarding Char-Broil® gas, charcoal, electric, and new infrared grills and cookers.

Be sure to check out our many grilling recipes and don't forget to sign up for our exciting newsletter *Sizzle on the Grill*™ to stay updated on new recipes, contests, and the latest happenings here at Char-Broil®.

Charbroil.com also offers on-line customer support for Char-Broil® products.



**Thank you for support, and
HAPPY GRILLING!**

www.charbroil.com
For all your grilling needs!