

**TREASURE HUNTER'S CODE OF ETHICS:**

1. Respect the rights and property of others.
2. Observe all laws, whether national, state or local.
3. Never destroy historical or archaeological treasures.
4. Leave the land and vegetation as it was. Fill in the holes.
5. All treasure hunters may be judged by the example you set. Always obtain permission before searching any site. Be extremely careful while probing, picking up, or discarding of trash. And ALWAYS COVER YOUR HOLES!

**FIRST TEXAS PRODUCTS  
5-YEAR LIMITED WARRANTY**

Bounty Hunter Metal Detectors are warranted against defects in workmanship or materials under normal use for five years from date of purchase to the original user. Liability in all events is limited to the purchase price paid. Liability under this Warranty is limited to replacing or repairing, at our option, any Bounty Hunter Detector returned, shipping cost prepaid, to First Texas Products. Damage due to neglect, accidental damage or misuse of this product is not covered by this warranty.

*Copyright ©MCMXCIX by First Texas Products*

*All rights reserved, including the right to reproduce this book, or parts thereof, in any form, except for the inclusion of brief quotations in a review.*

*Published by First Texas Products  
Bounty Hunter® is a registered trademark of First Texas Products*



**First Texas Products  
11900 Montana Ave.  
El Paso, TX 79936  
(915) 855-4206**

# A PRIMER TO THE DISPLAY AND DEMONSTRATION OF THE PIONEER 101 & PIONEER 202 METAL DETECTOR SERIES

How to display, demonstrate and effectively sell the Wal-Mart Pioneer Metal Detectors.

**Table of Contents:**

*Main Features of the Pioneer 101.....p.2*  
*Main Features of the Pioneer 202.....p.3*  
*Comparison Chart for a Quick Overview.....p.4*  
*Assembly Procedure for 101 & 202.....p.5*  
*Step-by-Step Procedure on 101 Demonstration.....p.6*  
*Step-by-Step Procedure on 202 Demonstration.....p.7*  
*The Basics of Metal Detecting 101.....p.8*  
*The Basics of Metal Detecting 202.....p.9*  
*Quick Reference for Frequently Asked Questions.....p.10 & 11*  
*A Basic Metal Detecting Glossary of Terms.....p.12 & 13*  
*Trouble-Shooting Pioneer 101.....p.14*  
*Trouble-Shooting Pioneer 202.....p.15*  
*Warranty Information.....back cover*



# MAIN FEATURES OF THE PIONEER 101

# TROUBLE-SHOOTING PIONEER 202

## PIONEER 101 FEATURES

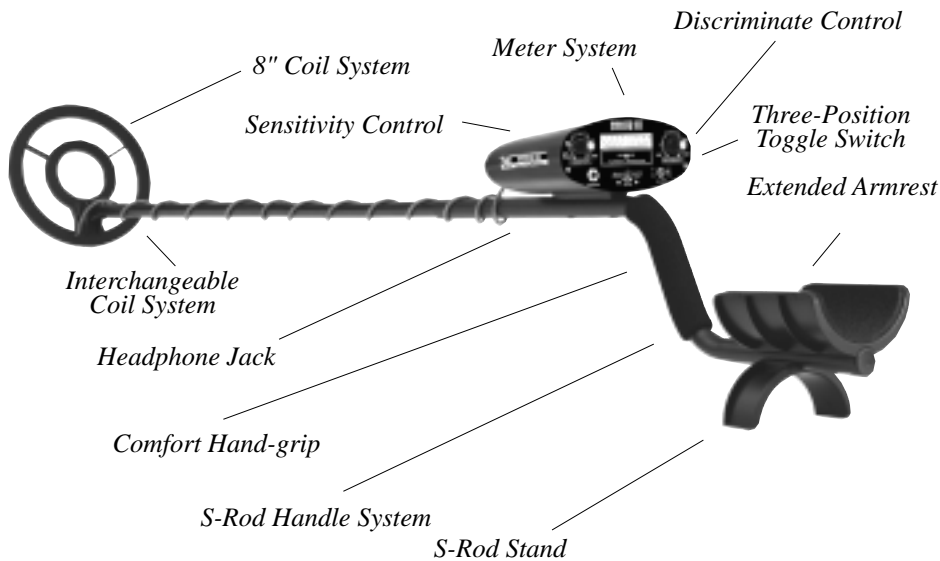

## PIONEER 101 FACEPLATE FEATURES

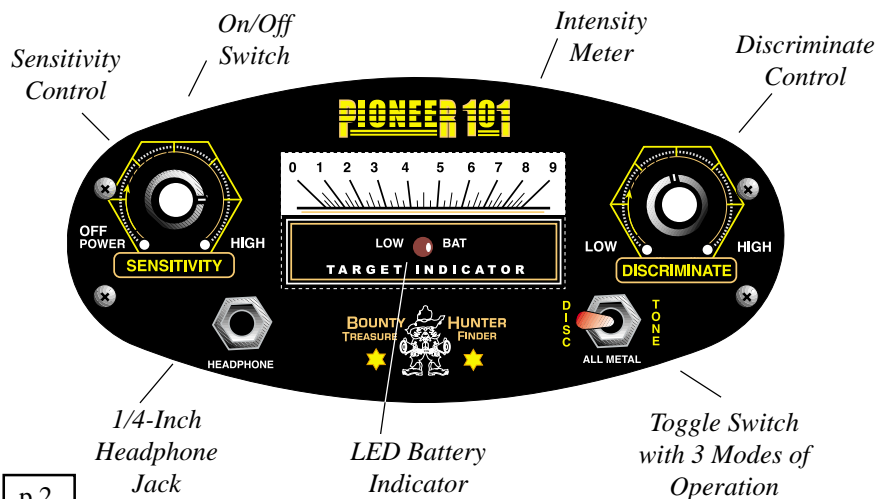

**THE PIONEER 202 IS EMITTING "GHOST" SIGNALS WHEN OPERATING IN THE FIELD.** The **SENSITIVITY** may be set too high. Try cutting back the **SENSITIVITY** slightly until the false signaling disappears. Remember to swing your coil slowly. Some ghost signals will occur on highly rusted metals. But if the signal does not repeat after successive passes of the coil over the same area, then the target is usually not worthwhile.

**THE PIONEER 202 LCD READOUT IS NOT LOCKING IN OR ID'ING WHILE PASSING OVER A TARGET & THERE IS MORE THAN ONE TONE BEING EMITTED BY THE DETECTOR OVER THE SAME TARGET.** This will usually occur when there is more than one object in the area you're sweeping. If it is an odd piece of metal that the detector cannot recognize, the meter will also not lock in. Sometimes, oxidation can cause erratic tones or inconsistent target identification. This may also occur if the **SENSITIVITY** is set too high.

**THE PIONEER 202 IS NOT STABLE AND HAS A PULSING, DISTORTED TONE INSTEAD OF A CLEAR TONE.** This can occur if operating near another detector or near power lines that can interfere with the frequency that the detector operates on.

**THE PIONEER 202 IS EMITTING A CONSTANT LOUD TONE OR CONSTANT REPEATING TONES.** This usually occurs when the batteries are low. Try replacing the batteries with two new alkaline batteries to determine if this is the cause.

**KEEP 2 DETECTORS AT LEAST 20FT APART.** If 2 detectors are in close proximity, interference from one to the other may cause the detector to emit erratic signals. By keeping the detector at a distance from other operating detectors, it will ensure no loss of performance or erratic "ghost" signals.

**NOTE:** Always use Alkaline Batteries for proper performance.

## TROUBLE-SHOOTING PIONEER 101

**THE PIONEER 101 IS EMITTING "GHOST" SIGNALS WHEN OPERATING IN THE FIELD.** The **SENSITIVITY** may be set too high. Try cutting back the **SENSITIVITY** slightly until the false signaling disappears. Remember to swing your coil slowly. Some ghost signals will occur on highly rusted metals. But if the signal does not repeat after successive passes of the coil over the same area, then the target is usually not worthwhile.

**THE PIONEER 101 IS NOT STABLE AND HAS A PULSING, DISTORTED TONE INSTEAD OF A CLEAR TONE.** This can occur if when operating near another detector or near power lines that can interfere with the frequency that the detector operates on.

**THE PIONEER 101 IS EMITTING A CONSTANT LOUD TONE OR CONSTANT REPEATING TONES.** This usually occurs when the batteries are low. Try replacing the batteries with two new alkaline batteries to determine if this is the cause.

**KEEP 2 DETECTORS AT LEAST 20FT APART.** If 2 detectors are in close proximity, interference from one to the other may cause the detector to emit erratic signals. By keeping the detector at a distance from other operating detectors, it will ensure no loss of performance or erratic "ghost" signals.

**NOTE:** Always use Alkaline Batteries for proper performance.

## MAIN FEATURES OF THE PIONEER 202

### PIONEER 202 FEATURES

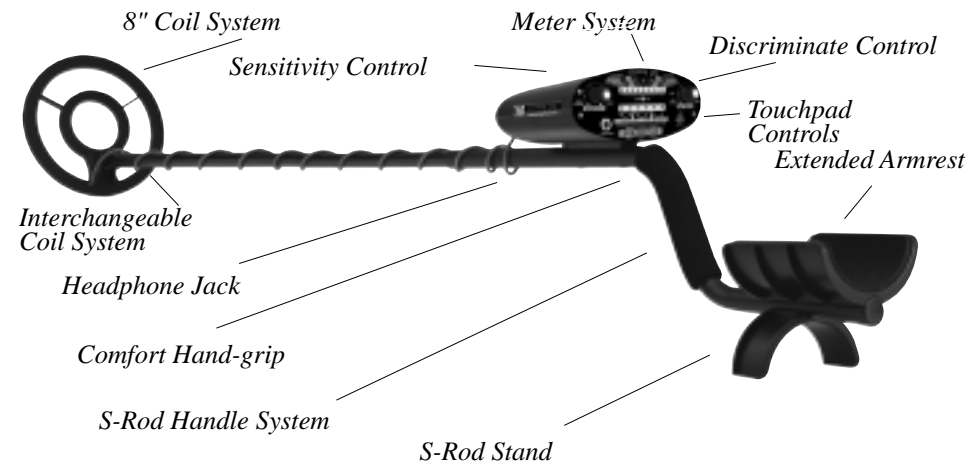

### PIONEER 202 FACEPLATE FEATURES

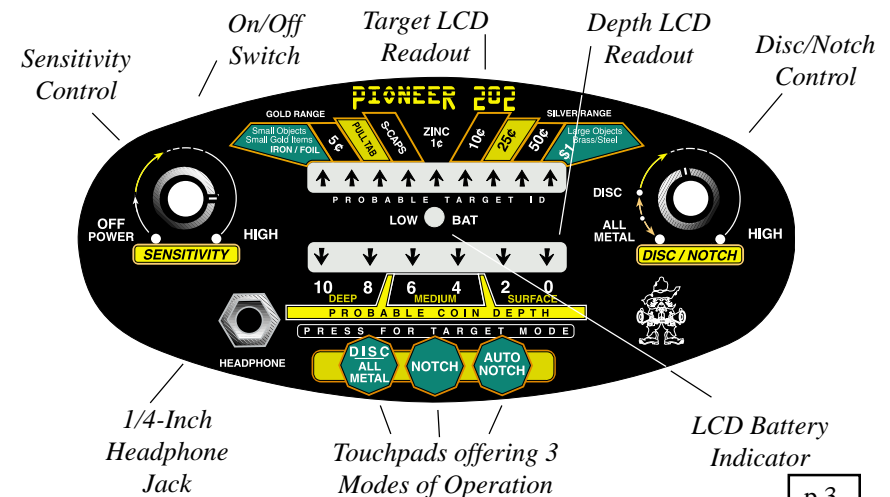

# COMPARISON CHART PIONEER SERIES

# GLOSSARY OF METAL DETECTING TERMS



## STANDARD FEATURES of Pioneer Series:

Adjustable Aluminum Stem  
S-Rod Handle System  
Motion Discrimination  
1/4" Headphone Jack  
Internal Speaker System

Interchangeable Coil System  
(Coil is Waterproof)  
Requires Two 9-Volt Alkaline  
Batteries (Not Included)  
5-Year Limited Warranty

Other Detector Features		
BOUNTY HUNTER MODELS →	Pioneer 101	Pioneer 202
FEATURES		
LCD Target Readout		✓
LCD Depth Readout		✓
Audio Battery Alert	✓	✓
Low Battery Indicator	✓	✓
Motion All Metal Mode	✓	✓
Intensity Meter	✓	
3 Modes of Operation	✓	
4 Modes of Operation		✓
Touchpad Selection		✓
Target Programmability		
2-Tone Audio Discrimination	✓	
3-Tone Audio Discrimination		✓
Sensitivity Adjustment	✓	✓
Discriminate Adjustment	✓	✓
Target Notch System		✓
Automatic Ground Balance	✓	✓
S-Rod Stand	✓	✓
Comfort Armrest	✓	✓
8" Open-Face Coil System	✓	✓

**Iron** — Iron is a common, low-grade metal which is often an undesirable target. Examples of undesirable iron objects are old cans, pipes, bolts, and nails.

**Masking** — When a good target is eliminated due to the closeness of a trash target.

**Mineralization** — Refers to soils containing ferric oxides or magnetic particles.

**Pull-tabs and Trash Items** — Discarded pull-tabs from beverage containers are the most bothersome items for professional and hobbyist metal detectorists. These items are generally constructed of aluminum, iron, or steel. We have therefore incorporated special features into the Pioneer 202 to eliminate these targets or to alert you to their possible presence.

**Relic** — A relic is an aged object of historical significance. Note that most relics are made of iron, an otherwise undesirable object in some metal detecting applications.

**Target ID** — Target Identification to identify detected metal objects.

**Target** — Refers to any object sensed by the detector.

**VLF: (Very Low Frequency)** — Most all detectors today are based on the VLF technology.

**Wheatie** — Any penny pre-1959 with the wheat straw symbol on the reverse of the coin.

**Zinc** — Any penny dated from 1982 and after/Usually very pitted when dug out of the ground.

## GLOSSARY OF METAL DETECTING TERMS

**A.T.I.** — Abbreviated term for Audio Target Identification. A certain audio pitch identifies the type of metal object located.

**Beaver Tail** — The tail of a pull-tab separated from the ring...usually giving the same signal as nickels and gold rings.

**Cache** — Usually any type of concealed treasure consisting of a quantity of money or other valuables.

**Clad** — Coins that are still in circulation...Usually dating from 1965 and on.

**Deep Signal** — A barely audible signal...The Bounty Hunter has a "loud alert" system which usually keeps the signals at a highly audible level no matter how deep the target is.

**Discrimination** — When the detector emits different tones for different types of metals, and when the detector "eliminates" certain metals, we refer to this as the detector "discriminating" among different types of objects.

**Disc.** — Abbreviated term for discrimination. Discrimination allows the detector to selectively reject certain metal objects or junk.

**Elimination** — Reference to a metal or target being "eliminated" means that the detector will not emit a tone nor light up an LCD indicator.

**Frequency** — Measured electric current...Most Bounty Hunter metal detectors operate at 6.6 kHz...6600 Hz.

**Halo Effect** — Certain metals when buried for long periods oxidize and leech into the surrounding soil. This results in a Metallic Halo around the buried object.

## ASSEMBLY PROCEDURE FOR 101 & 202

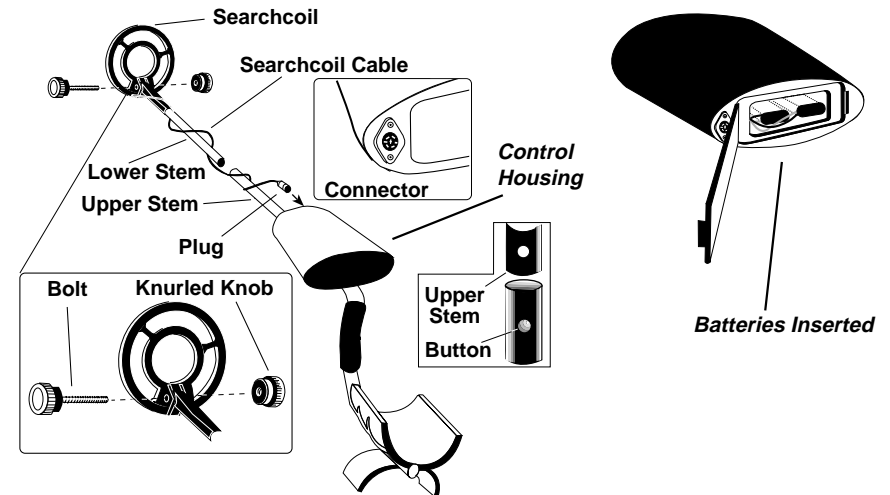

Assembling your Pioneer 101 Metal Detector is easy and requires no special tools. Just follow these steps:

1. Using the supplied bolt and knurled knob, attach the search coil to the lower stem.
2. Press the button on the upper end of the lower stem and slide the lower stem into the upper stem.

Adjust the stem to a length that lets you maintain a comfortable upright posture, with your arm relaxed at your side.

Maintain the search coil about 1/2 inch above the ground as you sweep.

3. Wind the search coil cable around the stem. Leave enough slack in the cable to let you adjust the coil when you are hunting on uneven ground. Then tighten the knob at the end of the search coil.

**Note:** To adjust the coil, simply loosen the knob.

4. Insert the coil's plug into the matching connector on the control housing. Be sure the holes and pins line up correctly.

**Caution:**

- Do not force the plug in. Excess force will cause damage.
- To disconnect the cable, pull out the plug. Do not pull on the cable.

# DEMONSTRATION PROCEDURE 101

# FREQUENTLY ASKED QUESTIONS

Here is a quick way to demonstrate the basic features of the PIONEER 101.

## I. Supplies Needed

- A quarter (25¢)
- A nickel (5¢)
- A Penny (1¢)
- Aluminum foil rolled into a small ball
- A Nail

## II. Position the Pioneer 101

- Place the detector on a table, with the search coil hanging over the edge.
- Be sure that the search coil is far away from walls or metal objects. Keep the search coil away from any metal in the table.

## III. Beginning Switch Settings

- Right Knob (Discriminate) – LOW
- Toggle Switch – Middle Position
- Turn detector on with "Sensitivity" knob set to 3/4

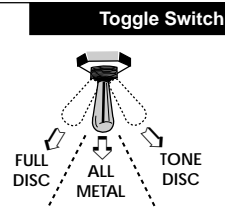

## IV. All Metal Detection

- A. Wave all objects over the search coil
- NOTICE THE SINGLE TONE

## V. Tone Mode Detection

- A. Move toggle switch to the right position – TONE
- B. Turn the "Discriminate" knob to 2:00 (about 3/4 turn)
- C. Sweep all of the different objects back and forth under the search coil
- NOTICE THE DIFFERENT TONES
  - NOTICE THE METALS REJECTED

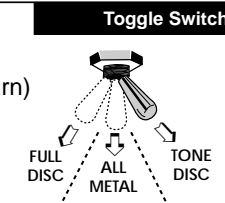

## VI. Disc Mode Detection

- A. Move the toggle switch to the left position – DISC
- B. Turn the "Discriminate" knob to LOW
- C. Sweep all of the different objects back and forth under the search coil.
- NOTICE THE METALS REJECTED
- D. Turn the "Discriminate" knob slowly to the right while sweeping all of the different objects at different settings.
- NOTICE THE DIFFERENT TONES
  - NOTICE THE METALS REJECTED

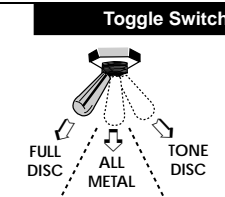

## Are the Pioneer metal detectors waterproof?

The search coils are submersible; the control panels are not waterproof. Although, you may fabricate a waterproof cover for the chassis for those occasions when you want to hunt in the rain. When detecting in saltwater conditions, always wipe your detector clean; saltwater can be extremely corrosive.

## What frequency does the Pioneer operate on?

6.6kHz.

## Does motion detection mean that if you stop the coil on top of an object the tone will go away? If so, how do you pinpoint an object that way?

Yes. It takes some practice to pinpoint accurately with a motion detection system. Try raising the coil as you're sweeping which will narrow the detection field and, in turn, focus the target area.

## What type of batteries does the Pioneer require? What affects battery life?

(2) 9-Volt Alkaline Batteries...Battery life is determined by many factors: Battery Quality, where you're hunting (trashy areas will drain a battery quicker because of the constant signal drain), whether you're operating with headphones or not (there is less draw when operating with headphones).

## Where can I hunt with the Pioneer?

The possibilities are truly endless. Just imagine, anywhere there's grass or dirt and people have been there, metal objects will be found! Whenever you see dirt or a grassy area, consider the possibilities. Sometimes a little research in the local library will reveal these types of potential sites. In conclusion, where to hunt is only limited by your own imagination. Always gain permission when hunting private property.



# FREQUENTLY ASKED QUESTIONS

## How deep will my metal detector go?

Many factors come into play when determining depth of a metal detector. In answering this question we will focus on the 3 main issues:

### 1. Soil Conditions

When hunting in high mineralization, such as wet salt areas or black sand, the detector may lose considerable depth depending on how well it's ground balanced.

### 2. Size of Object

The size of the object targeted will definitely influence what level of depth will be achieved. The larger the object, the deeper the detector will go.

### 3. How long the object was buried

If the object has been buried long enough to begin oxidizing, the object will have more of a halo effect thereby increasing the potential depth capability of your metal detector.

To illustrate a typical situation, with ideal soil conditions, expect at least 6 to 8 inches on older coins and 3 to 5 feet on larger objects. Handheld-type metal detectors will not detect at depths of 6-20 feet.

**Is there such a thing as a detector that will detect nothing but gold or other precious metals while eliminating all trash metal completely?**

No.



# DEMONSTRATION PROCEDURE 101

Here is a quick way to demonstrate the basic features of the PIONEER 202.

## I. Supplies Needed

- A quarter (25¢)
- A nickel (5¢)
- A dime (10¢)
- A penny (1¢)
- Aluminum foil rolled into a small ball
- A nail

## II. Position your Pioneer 202

- Place the detector on a table, with the search coil hanging over the edge.
- Be sure that the search coil is far away from walls or metal objects. Keep the search coil away from any metal in the table.

## III. Beginning Switch Settings

- Right Knob (DISC/NOTCH) — 100% counterclockwise to low
- Left Knob (SENSITIVITY) — click on and set to 3:00 (3/4 turn)
- Do not press any touchpads



## IV. All Metal Detection

- A. Wave all objects under the search coil
  - NOTICE THE TONES

## V. Discriminate Mode

- A. Turn the right knob (DISC/NOTCH) slowly to the right past the "DISC" indication.
- B. Wave all objects under the search coil at different "DISC" settings.
  - NOTICE THE DIFFERENT TONES
  - NOTICE THE METALS ELIMINATED

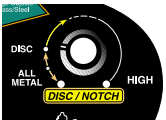

## VI. Notch Mode

- A. Press the NOTCH touchpad
- B. Right knob (DISC/NOTCH) 100% counterclockwise to low
- C. Wave all objects under the search coil while slowly turning the right knob clockwise.
  - NOTICE THE DIFFERENT TONES
  - NOTICE THE METALS ELIMINATED



## VII. Auto Notch Mode

- A. Press the AUTO NOTCH touchpad
- B. Right knob (DISC/NOTCH) 100% counterclockwise to low
- C. Wave all objects under the search coil while slowly turning the right knob clockwise.
  - NOTICE THE DIFFERENT TONES
  - NOTICE THE METALS ELIMINATED



## THE BASICS OF METAL DETECTING 101

The Pioneer 101 Metal Detector incorporates Motion Detection Technology. Movement over an object is required in order for the machine to detect the object and emit a tone.

While holding your Pioneer 101 Metal Detector as indicated in the picture to the right, sweep the search coil slowly from side to side. While sweeping, maintain the search coil level with the ground.



If the Detector chatters, reduce the sensitivity by turning the left knob (Sensitivity) counterclockwise.

When searching a possible target, move the search coil repeatedly over the target. Be certain that the signal repeats during each pass over the target. If the tone does not repeat consistently, the unit is probably detecting mineral deposits or oxidation. Only dig up targets with repeatable tones.

### CAUTION:

- Do not test the detector by placing coins or metal objects on the floor: Most floors contain metal, which will cause interference.
- Use 9-VOLT ALKALINE batteries only.

## THE BASICS OF METAL DETECTING 202

The Pioneer 202 Metal Detector incorporates patented microprocessor-controlled technology. The Pioneer 202 is a motion detector; movement over an object is required in order for the machine to detect the object and emit a tone. Alternatively, you can sweep a metal object over a motionless search coil.

### 1. ALL METAL DETECTION

All metals will be detected.

### 2. DISCRIMINATE, NOTCH, and AUTO NOTCH modes

In any of these three detection modes, the detector will emit different tones, depending upon the type of metal present. The characteristics are adjustable. Depending on the detector control settings, some metals will be eliminated from detection.

#### DISCRIMINATE:

Eliminates iron and trash items with the use of the DISC/NOTCH knob.

#### NOTCH:

Provides an adjustable rejection "window" to eliminate undesirable metals from detection. Enlarge the rejection "window" with the DISC/NOTCH knob.

#### AUTO NOTCH:

Provides a pre-set rejection "window", automatically eliminating most pull-tabs and trash items from detection. Enlarge the rejection "window" with the DISC/NOTCH knob.

If the Detector chatters, reduce the sensitivity by turning the left knob (Sensitivity) counterclockwise.

When searching a possible target, move the search coil repeatedly over the target. Be certain that the signal repeats during each pass over the target. If the tone does not repeat consistently, the unit is probably detecting mineral deposits or oxidation. Only dig up targets with repeatable tones.

### CAUTION:

- Do not test the detector by placing coins or metal objects on the floor: Most floors contain metal, which will cause interference.
- Use 9-VOLT ALKALINE batteries only.