

# Cuisinart™



## 7.0 QUART STAND MIXER



**RECIPE  
BOOKLET  
REVERSE  
SIDE**

For your safety and continued enjoyment of this product, always read the instruction booklet carefully before using.

### SM-70 INSTRUCTION BOOKLET

IB-6383

89280

## IMPORTANT SAFEGUARDS

When using an electrical appliance, basic safety precautions should always be followed to reduce the risk of fire, electric shock and/or injury, including the following:

1. READ ALL INSTRUCTIONS BEFORE USING.
2. Switch off and unplug before fitting or removing tools and/or attachments, after use and before cleaning.
3. Close supervision is necessary when any appliance is used by or near children. Cuisinart does not recommend the use of this appliance by children.
4. Avoid contact with moving parts and fitted attachments. Keep hands, hair, clothing, as well as spatulas and other utensils, away from beaters during operation to reduce the risk of injury to persons and/or damage to the mixer.
5. The use of attachments not recommended or sold by Cuisinart may cause fire, electric shock or injury.
6. Do not use more than one attachment at a time.
7. Do not exceed the maximum capacities listed in this use and care instruction book.
8. Do not use the stand mixer if it is damaged or if the cord is damaged. Have the stand mixer checked and serviced before resuming use.
9. When using an attachment make sure that you have read the safety instructions that come with the particular attachment.
10. Do not use outdoors.
11. Keep stainless steel bowl away from heat sources such as stovetops, ovens or microwaves.
12. To protect against the risk of electric shock do not put the power unit in water or other liquid.
13. Remove all attachments and accessories from stand mixer before washing.
14. Do not let cord hang over edge of table or counter.

## SAVE THESE INSTRUCTIONS FOR HOUSEHOLD USE ONLY

**NOTE:** The maximum rating is based on the attachment that draws the greatest power. Other recommended attachments may draw significantly less power.

### WARNING: RISK OF FIRE OR ELECTRIC SHOCK



The lightning flash with arrowhead symbol within an equilateral triangle is intended to alert the user to the presence of un-insulated dangerous voltage within the product's enclosure that may be of sufficient magnitude to constitute a risk of fire or electric shock to persons.



The exclamation point within an equilateral triangle is intended to alert the user to the presence of important operating and maintenance (servicing) instructions in the literature accompanying the appliance.

### SPECIAL CORD SET INSTRUCTIONS

A short power-supply cord is provided to reduce the risks resulting from becoming entangled in or tripping over a longer cord.

Longer extension cords are available and may be used if care is exercised in their use.

If a long extension cord is used, the marked electrical rating of the extension cord must be at least as great as the electrical rating of the appliance, and the longer cord should be arranged so that it will not drape over the countertop or tabletop where it can be pulled on by children or tripped over.

## NOTICE

This appliance has a three wire grounded plug. To reduce the risk of electric shock, this plug will fit in a polarized outlet only one way. If the plug does not fit fully in the outlet, reverse the plug. If it still does not fit, contact a qualified electrician.

Do not modify the plug in any way.

## CONTENTS

Important Safeguards.....	2
Features and Benefits .....	4
Assembly Instructions, Diagram .....	5
Operating Instructions.....	6
Cleaning and Maintenance .....	6
Suggested Speed Control Guide.....	7
Maximum Capacities.....	8
Troubleshooting.....	8
Tips and Hints .....	8
Cookie Baking .....	9
Bread Baking .....	9
Cake Baking .....	10
Whipping Cream.....	11
Optional Attachments .....	11
Warranty Information.....	12

## INTRODUCTION

This is the mixer that does it all! Your new extra-large Cuisinart™ 7 Quart Stand Mixer has the power, capacity and precision to handle any job your recipes require. With three accessories, you can mix, whip or even knead dough. With 12 speeds, you'll always do it just right. And with the auto shutoff Countdown Timer you'll always do it for just the right amount of time! Results will be perfect.

Cuisinart offers optional attachments that can be purchased separately. Each connects to one of three power outlets on the mixer to let you blend, process food, squeeze juice from your favorite citrus fruits, make perfect homemade pasta, or grind your own meats (see page 11 for details).



## FEATURES AND BENEFITS

- 1. Tilt-back Head**  
Makes it easy to attach accessories and scrape sides of bowl.
- 2. Top Cover**
- 3. High Speed Power Outlet**  
Blender and Food Processor attachments (sold separately) connect to the rear power outlet on top of the stand mixer.
- 4. Mid Speed Power Outlet**  
Citrus Juicer attachment (sold separately) connects to the front power outlet on the top of the stand mixer.
  - 4a. Mid Speed Power Outlet Plug**
- 5. Slow Speed Power Outlet**  
Large Meat Grinder and Pasta Maker attachments (sold separately) connect to the power outlet located behind the slow speed outlet cover on the front of the stand mixer head.
  - 5a. Slow Speed Outlet Cover Release Lever**
- 6. Accessory Power Port**  
Chef's whisk, flat mixing paddle, dough hook and splashguard connect to this port.
- 7. 7 Quart Stainless Steel Bowl with Handles**  
Handles make the bowl easy to hold, scrape and remove. Oversized bowl lets you mix larger quantities.
- 8. Head-lift Release Lever**  
Securely locks stand mixer head into raised tilt-back position.
- 9. On/Off, Fold and Speed Control Dial**  
12 speeds for precision mixing.
- 10. 15-Minute Countdown Timer with Auto Shutoff**  
Turns off stand mixer after selected time has elapsed.
- 11. Chef's Whisk**  
Used for incorporating air into ingredients/mixtures. Most frequently used for whipping eggs, egg whites or heavy cream. The chef's whisk would be used in recipes for angel food cake, chiffon cake, meringue or dacquoise, some types of candy such as divinity, and for whipping potatoes after they have been mashed using the flat mixing paddle.
- 12. Flat Mixing Paddle**  
Used for stirring, mixing, beating ingredients/mixtures. Most frequently used for mixing cookies, cakes, batters (use flat mixing paddle to start the batter for yeast breads then switch to dough hook for a more evenly mixed dough), and frostings. It is also used for making piecrusts, biscuits and shortcakes, dough for pasta, combining ingredients for meatloaf or meatballs, and mashing potatoes.
- 13. Dough Hook**  
Used for the final mixing and kneading of yeast doughs for breads, rolls, pizza/focaccia, and yeast-raised coffee cakes.
- 14. Splashguard with Pour Spout**  
Prevents spattering when mixing and adding ingredients.

## ASSEMBLY INSTRUCTIONS

- 1. Raise Mixer Head** – Pull up the head-lift release lever and raise the stand mixer head until it locks into place.
- 2. Attach Accessory** – Place flat mixing paddle, chef's whisk or dough hook into the accessory power port. Turn counterclockwise until it locks. Turn clockwise to remove.
- 3. Place Bowl on Base** – Turn clockwise to secure.
- 4. Lower Mixer Head** – Pull up head-lift lever again and fully lower the mixer head.
- 5. To Attach Splashguard** – Before attaching an accessory, raise stand mixer head and push the splashguard onto the rim above the accessory power port until it fully snaps into place.

**To remove:** Raise the stand mixer head and slide splashguard off rim.

**Note:** You do not need to remove splashguard to change accessories.

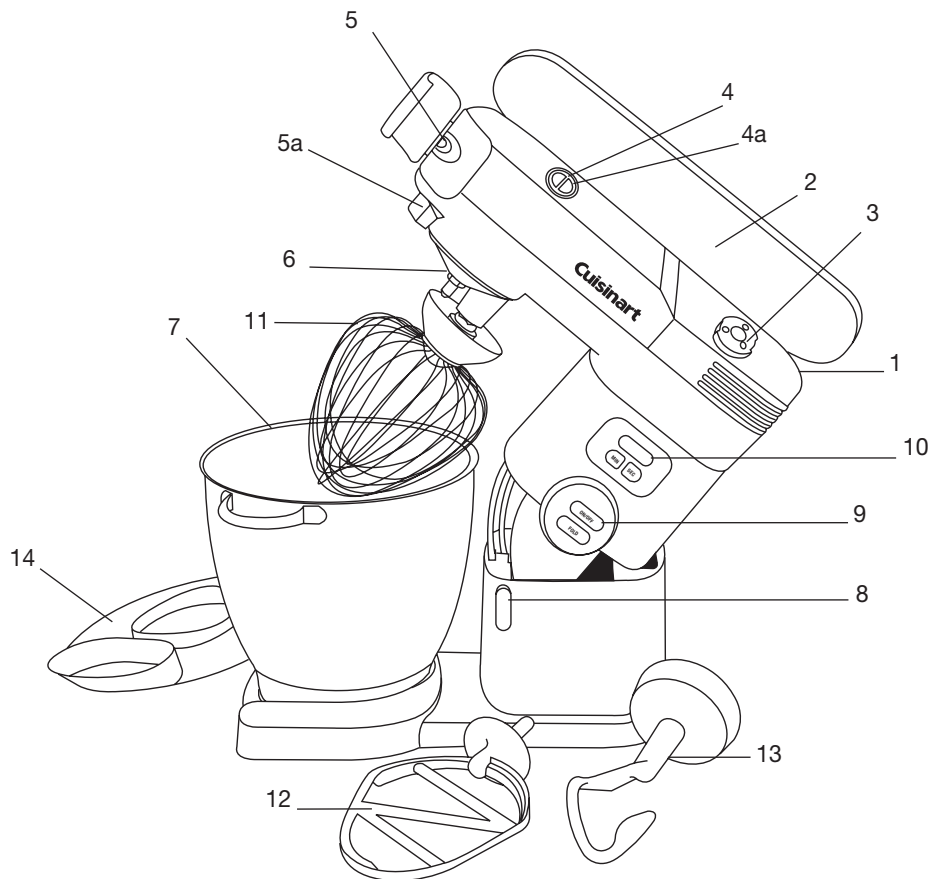

## OPERATING INSTRUCTIONS

### To Turn Stand Mixer On

1. Turn control dial to desired speed – 1 through 12 (see speed control guide on page 7).
2. Press the On/Off button in the center of the dial.

### To Turn Stand Mixer Off

1. Press the On/Off button – mixing process stops and unit shuts off.

### To Use Countdown Timer

1. **Select Speed** – Turn speed dial to desired speed.
2. **Activate Timer** – Press and hold the Minute or Second button until 00:00 begins to flash. Hold down either button to scroll through the digits, or press and release to advance one digit at a time until the desired time is displayed. Maximum time setting is 15 minutes.
3. **Begin Timed Mix** – Press the On/Off button in the center of the dial. Stand mixer starts and timer begins counting down.
4. **Automatic Shutoff** – Mixing process automatically stops when total time has elapsed. One tone signals shutoff.

### To Pause Countdown Timer

1. Press the On/Off button once to stop the stand mixer and interrupt countdown (number will flash to signify pause mode).
2. Check consistency, scrape bowl, add ingredients, etc.
3. Press the On/Off button again. The mixing process begins and the timer continues counting down the remaining time.
4. To add time during pause mode, press the Minute or Second button until the desired time is displayed.

**Safety Feature:** If there is no action on the unit after 5 minutes, the timer resets itself to “00:00”, a double tone sounds, and the unit shuts off.

### To Modify/Change Time During Use

1. Press and hold either the Minute or Second button until the current time begins to flash.
2. Unit is now in timer-set mode; use the Minute or Second button to select a new countdown setting.

### To Cancel Operation (Set back to 00:00)

1. **When unit is on** – Press and hold the On/Off button for 2 seconds. The timer resets to 00:00 and the unit shuts off.
2. **When unit is off** – Press and hold both the Minute and Second buttons for two seconds. The time will reset back to 00:00.

### To Use Fold Function

The fold operation allows you to mix in ingredients at the lowest speed.

The Fold button is located in the center of the dial.

1. **Continuous Fold** – Hold the Fold button down to blend ingredients; release to stop.
2. **Pulse Fold** – Press the Fold button repeatedly as needed to combine ingredients. Each pulse generates 1½ to 2½ revolutions of the flat mixing paddle, chef’s whisk or dough hook.

## CLEANING AND MAINTENANCE

Unplug your Cuisinart™ Stand Mixer before cleaning.

**Power Unit:** Wipe with a damp cloth and dry. Never use abrasives or immerse in water.

**Bowl:** Wash by hand and dry thoroughly or put in dishwasher. Never use a wire brush, steel wool or bleach.

**Tools:** Top rack dishwasher-safe; can also wash by hand and dry thoroughly.

**Splashguard with Pour Spout:** Top rack dishwasher-safe; can also wash by hand and dry thoroughly.

## SUGGESTED SPEED CONTROL GUIDE

<b>FOLD</b>	<ul style="list-style-type: none"> <li>• Adding ingredients at the end of mixing</li> <li>• Blending dry ingredients</li> </ul>		
<b>1</b>	<ul style="list-style-type: none"> <li>• Has the gentle start – use for stirring and starting all mixing/whipping tasks</li> <li>• Adding dry ingredients (flour) to batters and liquids to dry ingredients or batters</li> <li>• Begin creaming fats with sugars</li> <li>• Rubbing fat into flour for piecrusts, biscuits, scones</li> <li>• Begin to whip eggs or cream</li> <li>• Stirring ingredients to blend without adding air</li> <li>• Making crumb toppings</li> </ul>	<b>7</b>	<ul style="list-style-type: none"> <li>• Whipping potatoes</li> <li>• Whipping cream, cream cheese, or butter for easy spreading</li> </ul>
<b>2</b>	<ul style="list-style-type: none"> <li>• Stirring</li> <li>• Adding dry ingredients such as nuts, chocolate morsels, dried fruits</li> <li>• Creaming batters without adding air – such as cheesecake</li> <li>• Begin mashing potatoes</li> <li>• Mixing some pastry doughs</li> <li>• Mixing muffins</li> </ul>	<b>8</b>	<ul style="list-style-type: none"> <li>• Whipping cream</li> <li>• Whipping potatoes</li> <li>• Whipping egg whites – adding sugar to whipped egg whites</li> </ul>
<b>3</b>	<ul style="list-style-type: none"> <li>• Kneading yeast doughs</li> <li>• Creaming</li> <li>• Mixing batters, cookie doughs</li> <li>• Adding eggs to batter/dough</li> <li>• Mixing heavy ground meat mixtures (meatloaf, meatballs, pâté)</li> <li>• Mixing frostings</li> </ul>	<b>9</b>	<ul style="list-style-type: none"> <li>• Whipping egg whites</li> <li>• Whipping cream</li> </ul>
<b>4</b>	<ul style="list-style-type: none"> <li>• Mixing packaged cake mixes</li> <li>• Mixing batters, cookie doughs</li> <li>• Creaming to make light and fluffy</li> <li>• Adding eggs to batter/dough</li> <li>• Mixing frostings</li> </ul>	<b>10</b>	<ul style="list-style-type: none"> <li>• Whipping cream – using gradual increase from Speed 1</li> <li>• Whipping egg whites</li> <li>• Whipping butter to make compound or whipped butters</li> <li>• Mixing egg/sugars mixtures until light and fluffy</li> </ul>
<b>5</b>	<ul style="list-style-type: none"> <li>• Creaming to make light and fluffy</li> <li>• Adding eggs to creamed mixtures</li> <li>• Mixing frostings</li> </ul>	<b>11</b>	<ul style="list-style-type: none"> <li>• Whipping egg whites</li> <li>• Whipping frostings until fluffy</li> </ul>
<b>6</b>	<ul style="list-style-type: none"> <li>• Adding eggs to creamed mixtures</li> <li>• Mashing potatoes</li> <li>• Whipping egg whites until frothy</li> <li>• Beating whole egg yolks until ribbons form</li> </ul>	<b>12</b>	<ul style="list-style-type: none"> <li>• Whipping egg whites – using gradual increase from Speed 1</li> <li>• Whipping frostings until fluffy</li> </ul>

## MAXIMUM CAPACITIES FOR THE CUISINART™ STAND MIXER

7 Quart Stand Mixer	
Yeast dough (most breads, pizza)	15 cups flour
Cookie dough	15 dozen cookies
Whipping cream	8 cups
Egg whites	16

## TROUBLESHOOTING

**1. Problem:** The accessories knock against the bottom of the bowl or are not reaching the ingredients at the bottom of the bowl.

**Solution:** Adjust the height by doing the following:

- Detach the accessory.
- Hold and loosen the nut as shown.

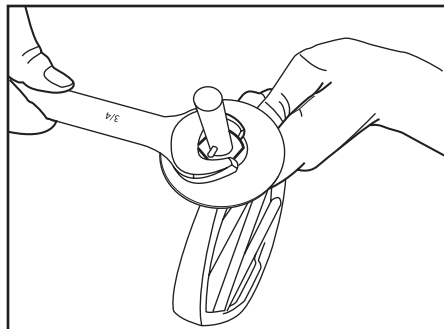

- For ideal operation, the chef's whisk and flat mixing paddle should be almost touching the bottom of the bowl.
  - Raise the stand mixer head, hold the accessory in place, and tighten.
- 2. Problem:** Your stand mixer has an overload protection device and if overloaded, it will shut down to protect the motor.

**Solution:** In the unlikely even that this happens:

- Turn off and unplug the unit.

- Reduce the load by removing some of the ingredients, and allow the mixer to stand for a few minutes.
- Plug in and reset the speed. If the stand mixer does not start when you press the on button, allow the unit to stand for additional time.

## TIPS AND HINTS

- Before preheating the oven, adjust shelves to accommodate your baking task. Pies bake best when baked in the lower third of the oven.
- Carefully follow each mixing step in a recipe. Take care not to over- or under-mix. Make use of the Countdown Timer feature of the Cuisinart™ Stand Mixer to help with suggested mixing times.
- Don't crowd the oven, and avoid opening the oven door during baking – use the oven light to help you watch. With certain recipes, particularly cookies, when baking more than one pan in the oven at a time, rotate pans halfway through the baking cycle.
- Proper measurements are very important when baking. To measure flour correctly, stir the flour first, then spoon into the measuring cup. Level off the top with the blunt side of a knife blade or the handle of a spoon. Do not press or compact flour. It is also very important not to measure directly from the bag – while the flour is pre-sifted, it has been pressed/compacted to fit into the bag. Baked goods made from unstirred flour are likely to be heavy and dry because too much flour is used.
- Remove butter from the refrigerator and cut into ½-inch pieces to help it come to room temperature faster while you measure out the remaining ingredients. Do not warm butter in the microwave; this can change the structure of the butter if it melts and give the finished product a different texture.
- To separate eggs for use in any recipe, break them one at a time into a small bowl. Gently remove the yolks, then transfer the whites to a spotlessly clean glass or stainless bowl. If a yolk breaks into a white, use that egg for another recipe. Just a drop of egg yolk in the white prevents the white from whipping properly.

- For whipping egg whites, both the mixing bowl and chef's whisk must be spotlessly clean and dry. Any trace of fat or oil will prevent the egg whites from whipping properly.
- To check the freshness of eggs, place them in a bowl of warm water – if they float, they are not fresh.
- To melt chocolate for a recipe, place chopped chocolate in a double boiler insert or larger bowl over a pan of barely simmering hot water. The water should not boil, nor should it touch the bottom of the double boiler insert or bowl. If it does, this could cause the chocolate to "seize" and you will not be able to use it in your recipe.
- Always test yeast for freshness before using it in a recipe. Sprinkle a little over warm (105-110°F) water from recipe and add a pinch of sugar or flour from the recipe. If it does not become foamy/bubbly in 5 to 10 minutes, the yeast may be "dead." Start over with fresh yeast from a new package.
- For mixing yeast doughs, begin by using the flat mixing paddle. When starting a recipe, dough is thinner and more like a batter and mixes more efficiently and smoothly with a paddle. After a very thick, smooth batter forms, switch to the dough hook to complete the recipe.

## COOKIE BAKING

- Use an ice cream scoop to measure out cookie dough – this keeps the cookies evenly shaped and uniform in size. We recommend ice cream scoops in several sizes – #'s 40, 50 and 60, as well as a larger one (about 1/3 to 1/2 cup) for jumbo cookies. Ice cream scoops, also known as "dishers" are also good for filling muffin tins. Use a #16 ice cream scoop to make muffins or meatballs.
- To better maintain cookie shapes, put scoops of cookie dough onto sheets of waxed paper or plastic wrap on a tray and chill before baking. Most cookie dough can be refrigerated for 2 to 3 days prior to baking – be sure to wrap well.
- Cookie dough may also be frozen. Shape into individual cookies, double wrap and freeze for up to 3 months.

- Line baking sheets with parchment for easy release and easy cleanup.
- Let cookies rest on sheets for 2 to 3 minutes before removing them to a wire rack to cool. This keeps cookies from wrinkling, crumbling or breaking.
- Cookies must cool completely before being put into storage containers to avoid them becoming soggy and misshapen.

## BREAD BAKING

- One 1/4-ounce packet of yeast equals 2 1/4 teaspoons yeast.
- Using milk in place of water will produce a softer crust.
- After baking, you can soften the crust, if desired, by rubbing it with unsalted butter soon after removing it from the oven. This prevents it from drying out too quickly.
- If a recipe calls for a specific type of flour, used the flour recommended. If you do not have bread flour, you can substitute unbleached, all-purpose flour, but your bread may not rise quite as much.
- Do not use "lite" or tub margarines for bread baking – the first ingredient is often water and they do not work well in any baking.
- Vital gluten is the dried protein taken from the flour by eliminating the starch. It is a good dough conditioner or enhancement for yeast breads, especially for whole grain breads or when using all-purpose flour. If a recipe specifically calls for vital gluten, we recommend that it be used for best results.
- For 100% whole wheat bread use 1 1/2 teaspoons vital gluten per cup of flour.
- Lite salt can be used if it has both potassium chloride and sodium.
- Many bread recipes have a "range" amount of flour – start by using the lower end of the range, then add more flour as needed to produce a smooth, not sticky dough.
- Before measuring molasses or honey, oil the measuring spoon to help it run off better.
- To produce a higher loaf of bread, use water that potatoes have been cooked in.

- Using too much liquid, or baking on a humid day, can cause your bread to fall or wrinkle on top.

## CAKE BAKING

- Have all ingredients and mixing bowls at room temperature (BUT when preparing whipped cream as a topping, bowl, chef's whisk, and cream should be refrigerator-cold). Room temperature ingredients incorporate and blend more easily.
- Fill pans immediately after mixing.
- Bake immediately after filling pans.
- Check for doneness at the beginning of the time range given.
- Cool cakes completely on a wire rack after baking.
- Using an offset spatula will make spreading frosting easier.

### Egg Whites

Egg whites at room temperature are best for whipping. Bring to temperature safely by placing eggs in a bowl of warm water for 10 to 15 minutes.

Add a small amount of acid such as cream of tartar, lemon juice or vinegar when whipping egg whites to stabilize them and allow them to reach their optimum volume and stiffness. Use  $\frac{1}{8}$  teaspoon cream of tartar per large egg white – or 1 teaspoon cream of tartar per cup of egg whites (8 to 10 large).

The time required to whip egg whites will vary with the temperature of the egg whites, age of egg whites, and temperature/humidity of the kitchen. Keep a close watch while whipping egg whites.

In humid or damp weather, you may not get the volume of whipped egg whites that you do in drier, warmer weather.

Place the room temperature egg whites in the clean, dry mixing bowl. Attach the clean, dry chef's whisk. Start whipping the egg whites and gradually increase to speed 6 until foamy, and then gradually increase to speed 12. If egg whites are beaten too rapidly in the beginning, their structure will not be as stable and strong, and they will not reach the volume that they should when completely beaten. Over-beaten egg whites will also separate or weep in a meringue topping.

Timing when adding sugar to egg whites is important. If adding less than  $\frac{1}{4}$  cup (4 tablespoons), add it in the beginning at the raw white stage. For larger amounts, add sugar slowly and gradually to the whipped egg whites after they reach soft peak stage. Always add sugar in a slow steady stream while egg whites are being whipped – do not add sugar directly to the center of the bowl on top of beaten egg whites; doing this may cause them to deflate.

When whipping egg whites, they will at first appear foamy or frothy. Then they will become stiffer and start to hold their shape. Next, soft peaks will form – this is when the tips of the peaks fall when the whisk is lifted up – soft peaks are often required for mousses or soufflés. The next stage is almost stiff to stiff peaks. This is used for recipes such as meringues – the whites will appear dry, the peaks will hold their shape, and the whites will be shiny. The final stage is stiff and dry. The whites will not be uniformly white, but will appear speckled, and they will no longer be shiny in appearance.

Beaten egg whites should be used immediately after beating them. If they wait for longer than 5 minutes, they will begin to deflate and lose volume and structure. Egg whites beaten with sugar or cream of tartar are more stable and will last a little longer.

### Sanitizing Egg Whites

Take care when adding raw egg whites to recipes that are not cooked or baked as there is a chance they may carry harmful bacteria. If you have a recipe that calls for raw egg whites, you may wish to use powdered egg whites or "sanitize" the egg whites by doing the following: Place the egg whites, 2 tablespoons of the granulated sugar from your recipe, 2 tablespoons water, and a pinch of cream of tartar in the Cuisinart™ mixing bowl and stir until smooth. Place over the pan of simmering water and stir constantly with a spotlessly clean rubber spatula until the mixture registers 160°F on an instant-read thermometer – start checking the temperature after about a minute of stirring. When the egg white mixture registers 160°F, dry off the bottom of the bowl and place on the Cuisinart™ stand mixer. Insert the chef's whisk. Continue as directed in your recipe.

## WHIPPING CREAM

The difference between heavy cream and whipping cream is the butterfat content. The higher the butterfat content, the more stable the whipped cream. Heavy cream has a higher butterfat content than whipping cream does. Light cream may also be whipped, but will not last as long. Creams that are not ultra-pasteurized are best for whipping.

The yield of cream generally doubles in volume. To make 2 cups of softly whipped cream, pour 1 cup of heavy/whipping cream into the well-chilled mixing bowl. Starting on speed 1 and increasing to speed 10 or 12, whip until it just begins to hold its shape. Add about ½ teaspoon pure vanilla or other pure flavored extract and 1 to 2 tablespoons granulated or superfine sugar. Whip until the cream holds soft, floppy peaks.

### To make whipped cream

- Start with well-chilled cream, mixing bowl and chef's whisk (place bowl and whisk in freezer for at least 15 minutes before making whipped cream). The room should not be too hot.
- Whip cream on low speeds until small bubbles foam – this will take about 30 seconds.
- Gradually increase to speed 6 and continue beating until the whisk leaves a trail.
- If you are making a sweetened, flavored whipped cream, begin to slowly add the sugar and flavorings as the cream becomes soft and billowy in appearance.
- Increase to speed 8 or 10 – but do not look away – it takes just seconds for cream to go from smooth and creamy whipped cream to whipped cream with grainy bits of butter forming.
- Stop whipping cream when it has doubled in volume – it should be smooth, creamy and thick, forming either soft (for garnishing desserts, folding into desserts) or stiff (for topping cakes, desserts, piping decoratively) peaks.
- Unless stabilized, whipped cream should be served immediately.

### Stabilized whipped cream

Stabilized whipped cream will hold longer in the refrigerator before using, and it can

also be used for decorating using a pastry bag and tip. Using gelatin or a purchased stabilizer will prevent whipped cream from weeping.

To make stabilized whipped cream, soften gelatin by sprinkling it over water in a measuring cup. Let stand 5 minutes to soften. Then place the measuring cup in a pan of simmering water and stir over low heat until gelatin is dissolved. Let cool slightly before adding to cream – but do not allow to get cold and harden.

- For 1 cup of cream, use ½ teaspoon gelatin soaked in 1 tablespoon water.
- For 2 cups of cream, use 1 teaspoon gelatin soaked in 2 tablespoons water.
- For 8 cups of cream, use 1 tablespoon + 1 teaspoon gelatin soaked in 8 tablespoons water.

Follow basic whipping instructions, adding cooled gelatin mixture to cream all at once after it is whipped to a slightly thickened stage.

## OPTIONAL ATTACHMENTS AND ACCESSORIES

Your Cuisinart™ Stand Mixer has three power outlets – two on the top and one on the front – for a variety of attachments that can be purchased separately.

Simplify your life, and save valuable counter space, by using your stand mixer as a power source for these versatile attachments:

**Pasta Maker** – makes delicious homemade pasta. Includes six pasta plates, from spaghetti to lasagna.

**Large Meat Grinder** – grinds a variety of meats, vegetables, and cheeses. Includes 3 grinding plates and 2 nozzles for making homemade sausage.

**40-ounce Glass Blender** – blends frozen drinks, smoothies and shakes, and even purées soups and sauces.

**Citrus Juicer** – extracts nutritious juice from all your favorite citrus fruits.

**Food Processor** – chops, purées, slices, and shreds in clear 3-cup work bowl. Includes a chopping blade and a reversible slicing/shredding disc.

## WARRANTY

### Limited Three-Year Warranty

This warranty is available to consumers only. You are a consumer if you own a Cuisinart™ Stand Mixer which was purchased at retail for personal, family or household use. Except as otherwise required under applicable law, this warranty is not available to retailers or other commercial purchasers or owners.

We warrant that your Cuisinart™ Stand Mixer will be free of defects in materials and workmanship under normal home use for 3 years from the date of original purchase.

We suggest you complete and return the enclosed product registration card promptly to facilitate verification of the date of original purchase. However, return of the product registration card does not eliminate the need for the consumer to maintain the original proof of purchase in order to obtain the warranty benefits. In the event that you do not have proof of purchase date, the purchase date for purposes of this warranty will be the date of manufacture.

If your Cuisinart™ Stand Mixer should prove to be defective within the warranty period, we will repair or, if we think necessary, replace it. To obtain warranty service, please call our Customer Service Center toll-free at 1-800-726-0190 or write to:

Cuisinart  
150 Milford Road  
East Windsor, NJ 08520

To facilitate the speed and accuracy of your return, enclose \$10.00 for shipping and handling. (California residents need only supply a proof of purchase and should call 1-800-726-0190 for shipping instructions.) Please be sure to include your return address, description of the product's defect, product serial number, and any other information pertinent to the return. Please pay by check or money order.

**NOTE:** For added protection and secure handling of any Cuisinart® product that is being returned, we recommend you use a traceable, insured delivery service. Cuisinart cannot be held responsible for in-transit damage or for packages that are not delivered to us. Lost and/or damaged products are not covered under warranty.

Your Cuisinart™ Stand Mixer has been manufactured to the strictest specifications and has been designed for use only with authorized accessories and replacement parts.

This warranty expressly excludes any defects or damages caused by accessories, replacement parts or repair service other than those authorized by Cuisinart.

This warranty does not cover any damage caused by accident, misuse, shipment or other than ordinary household use.

This warranty excludes all incidental or consequential damages. Some states do not allow the exclusion or limitation of these damages, so they may not apply to you.

#### CALIFORNIA RESIDENTS ONLY

California law provides that for In-Warranty Service, California residents have the option of returning a nonconforming product (A) to the store where it was purchased or (B) to another retail store which sells Cuisinart products of the same type. The retail store shall then, according to its preference, either repair the product, refer the consumer to an independent repair facility, replace the product, or refund the purchase price less the amount directly attributable to the consumer's prior usage of the product. If the above two options do not result in the appropriate relief to the consumer, the consumer may then take the product to an independent repair facility if service or repair can be economically accomplished. Cuisinart and not the consumer will be responsible for the reasonable cost of such service, repair, replacement, or refund for nonconforming products under warranty.

California residents may also, according to their preference, return nonconforming products directly to Cuisinart for repair or, if necessary, replacement by calling our Consumer Service Center toll-free at 800-726-0190. Cuisinart will be responsible for the cost of the repair, replacement, and shipping and handling for such nonconforming products under warranty.

#### BEFORE RETURNING YOUR CUISINART PRODUCT

Important: If the Cuisinart™ Stand Mixer is to be serviced by someone other than Cuisinart's Authorized Service Center, please remind the servicer to call our Consumer Service Center to ensure that the problem is properly diagnosed, the product serviced with the correct parts, and to ensure that the product is still under warranty.

©2006 Cuisinart  
Cuisinart® is a registered  
trademark of Cuisinart

150 Milford Road  
East Windsor, NJ 08520  
Printed in China

06CU26054

*7-Quart Stand Mixer*  
**recipes**



**Cuisinart**  
SAVOR THE GOOD LIFE®

# Recipes



## **savories** *easy and delicious*

savory gorgonzola and caramelized onion cheesecake . . . . .	4
manchego rosemary cheese puffs . . . . .	5
goat cheese and roasted garlic mashers . . . . .	6
sweet potato soufflé . . . . .	7
four-cheese soufflé . . . . .	8
souffléed potatoes with brie . . . . .	9
meatloaf with mushrooms . . . . .	10
turkey and spinach meatballs . . . . .	11
pizza rustica . . . . .	12

## **yeast breads** *and rolls*

basic white bread . . . . .	13
molasses wheat bread . . . . .	14
crusty french bread . . . . .	15
cranberry walnut pumpernickel bread . . . . .	16
mixed grain, seed and nut bread . . . . .	17
sun-dried tomato and basil bread . . . . .	18
buttery dinner rolls . . . . .	19
basic dough for pizza, focaccia or calzones . . . . .	20
grape tomato and herb focaccia . . . . .	21
parmesan herb knots . . . . .	22
classic brioche . . . . .	23
moravian sugar cakes . . . . .	24
cinnamon swirl buns . . . . .	25



## **muffins, quick breads** *and tea cakes*

banana bran muffins . . . . .	26
three-berry muffins . . . . .	27
oatmeal pear crumb muffins . . . . .	28
vanilla yogurt scones . . . . .	29
almond shortcakes with fresh berries, stone fruits and sweetened whipped cream . . . . .	30
buttermilk blueberry crumb cake . . . . .	31
lemon poppy seed cake . . . . .	32
sour cream cinnamon walnut streusel coffee cake . . . . .	33

## **cookies** *and classic treats*

dried cherry and almond biscotti . . . . .	34
almond thumbprints . . . . .	35
chocolate cherry crackles . . . . .	36
chocolate chunk macadamia cookies . . . . .	37
black and white pinwheels . . . . .	38
citrus sugar cookies . . . . .	39
pecan shortbread linzer cookies . . . . .	40
peanut butter surprise cookies . . . . .	41
mini morsel sugar cookies . . . . .	42
delicious brownies . . . . .	43

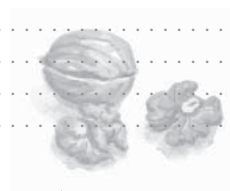

## **pies, mousses, soufflés** *and special desserts*

basic flaky pastry dough . . . . .	44
cookie crumb crust . . . . .	45
chocolate almond cream pie . . . . .	46
mile high lemon meringue pie . . . . .	47
pumpkin mousse pie . . . . .	48
raspberry mascarpone mousse . . . . .	49
sinfuilly rich chocolate mousse . . . . .	50
classic tiramisù . . . . .	51

## **frostings** *and fillings*

chocolate frosting . . . . .	52
swiss buttercream . . . . .	52
cream cheese frosting . . . . .	53
chocolate glaze/ganache . . . . .	53

## **cakes** *and cheesecakes*

golden layer cake . . . . .	54
rich chocolate cake . . . . .	55
old-fashioned pound cake . . . . .	56
kahúla® angel food cake . . . . .	57
coconut cake . . . . .	58
fresh ginger cake . . . . .	59
the ultimate flourless chocolate cake . . . . .	60
sour cream cheesecake . . . . .	61
chocolate marble cheesecake . . . . .	62



Cuisinart® is a registered trademark of Cuisinart. Any trademarks or service marks of third parties used herein are the trademarks or service marks of their respective owners.

## savory gorgonzola *and caramelized onion* cheesecake

Serve with crackers or bread with an aperitif, wine or port, or add a slice to a lightly dressed arugula salad.  
Adding fresh fruit such as figs, pears or currants to the plate would be perfect.

Makes one 8-inch cheesecake

- unsalted butter for the springform pan*
- 1 *tablespoon unsalted butter*
- 1 *tablespoon extra virgin olive oil*
- 3 *cups chopped onions*
- 1 *tablespoon tarragon*
- 1½ *cups finely ground stoned wheat cracker crumbs*
- 3 *tablespoons melted unsalted butter*
- 1½ *pounds lowfat cream cheese, at room temperature*
- 1 *pound regular cream cheese, at room temperature*
- 4 *large eggs, at room temperature*
- 1 *tablespoon fresh lemon juice*
- ¼ *teaspoon freshly ground white pepper*
- 1 *pound Gorgonzola dolce, crumbled*

Heat butter and oil in a 12-inch skillet over medium heat. Add onions and sauté for 5 minutes. Reduce heat to medium-low and cook slowly, stirring frequently, until onions are tender and deep golden, about 25 minutes. Stir in tarragon. Remove from heat and cool completely.

Preheat oven to 350°F. Lightly coat an 8x3-inch springform pan with unsalted butter. Combine cracker crumbs and melted butter. Dust sides of pan with buttered cracker crumbs and place remainder in bottom of pan; press to cover the bottom evenly. Use the bottom of a drinking glass or measuring cup to tamp down firmly. Bake in preheated 350°F for 8 to 10 minutes. Let cool while preparing filling. Reduce oven temperature to 325°F. When pan has cooled, line the outside of the springform pan with foil to waterproof it.

Place both types of cream cheese in Cuisinart™ mixing bowl. Insert the flat mixing paddle. Turn to speed 3 and mix for 2 minutes. Scrape mixing bowl and paddle. Mix again on speed 3 for 2 minutes until completely smooth and creamy. Decrease to speed 2. While mixing, add the eggs, one at time, mixing each egg in completely before adding the next. Scrape the bowl and paddle. Add the lemon juice and pepper and mix for an additional 30 seconds on speed 2. Add the crumbled Gorgonzola and press Fold until Gorgonzola is mixed in – do not over-mix. Pour into the cooled pan and smooth over the top evenly. Place the pan in a larger pan and add enough boiling hot water to reach halfway up the sides of the smaller pan. Place in preheated 325°F oven and bake for 1 hour. Top will be golden brown and slightly cracked; center will still appear soft. Transfer to a wire rack, remove the foil and cool. Cover and refrigerate when cool.

Remove from refrigerator 30 minutes before serving.



## manchego rosemary *cheese puffs*

*These are great to serve with wine or dry sherry as an hors d'oeuvre.*

Makes about 90 puffs

- 3 cups unbleached, all-purpose flour
- 1 tablespoon baking powder
- 1½ teaspoons sea salt  
*(use sea salt for added flavor)*
- 1 teaspoon dry mustard powder
- 1½ tablespoons dry rosemary
- ¾ pound unsalted butter, at room temperature, cut into 24 pieces
- 1 cup slivered almonds
- ¾ teaspoon Tabasco® or other hot sauce
- 1½ pounds shredded Manchego® cheese

Place the flour, baking powder, sea salt, dry mustard, and rosemary in a medium bowl. Stir with a whisk to blend. Reserve.

Place butter in Cuisinart™ mixing bowl. Insert flat mixing paddle. Turn to speed 4 and mix until light and fluffy, about 1 minute. Add half of the dry ingredients. Turn to speed 2 and mix until combined, about 1 minute. Add remaining dry ingredients and mix until smooth, about 1 minute. With the stand mixer running, add the almonds, hot sauce and a handful of the cheese.

Continue adding cheese a handful at a time until all cheese is added and completely combined. Shape into walnut-sized balls (1 inch in diameter; you may use a #50 ice cream scoop). Refrigerate 1 hour or longer (may be frozen).

Preheat oven to 350°F. Line baking sheets with parchment. Bake until lightly browned and puffed, about 20 minutes. Remove and place on a wire rack to cool. May be served warm or at room temperature.



## goat cheese *and roasted garlic mashers*

*A nice flavor addition for your favorite mashed potatoes.*

Makes 10 cups

- 5 pounds Yukon Gold potatoes, peeled and cut into 1-inch cubes
- 1 tablespoon kosher salt
- 10 ounces soft, fresh chèvre
- 8 tablespoons unsalted butter, at room temperature
- 12-14 roasted garlic\* cloves

Place potatoes in a 6-quart stockpot and cover with water by 1 inch. Add 1 tablespoon kosher salt to the water. Bring water to a boil and then reduce to a hearty simmer. Cook potatoes until very tender, about 30 minutes. Drain potatoes and then return to pot over low heat. Heat to dry out potatoes, about 3 to 5 minutes.

Transfer potatoes to Cuisinart™ mixing bowl. Insert the chef's whisk. Mix on speed 6 for about 3 minutes. Scrape bowl with a rubber spatula and mix again on speed 6 for another 2 minutes, until potatoes are completely mashed with no lumps. Turn stand mixer to speed 3 and mix in the chèvre until completely incorporated, and then the butter until completely incorporated. Add garlic cloves one at a time. When 10 are added, taste. Add additional cloves to individual taste. Add an additional ½ teaspoon of salt if necessary.

Serve immediately.

\*To roast garlic: place peeled garlic cloves on a sheet of aluminum foil, drizzle with olive oil and wrap together. Place in 400°F oven for about 30 to 35 minutes, until lightly browned and soft.



## sweet potato *soufflé*

*A tasty side dish for your next holiday meal.*

Makes one 8-cup soufflé

*unsalted butter*  
*½ cup chopped, toasted pecans*  
*4 pounds sweet potatoes or yams*  
*3 large eggs*  
*2 tablespoons unsalted butter*  
*¼ cup brown sugar*  
*½ teaspoon kosher salt*  
*1 teaspoon orange zest*

Butter an eight-cup soufflé dish well and coat with chopped pecans, and set aside.

Preheat oven to 400°F. Wrap each potato in aluminum foil and place on a baking sheet lined with foil. Bake for about 1½ to 2 hours, until extremely soft.

Reduce oven temperature to 350°F.

Once sweet potatoes are cool enough to touch, split down the middle and scoop out the insides. Place them in the Cuisinart™ mixing bowl. Insert the chef's whisk. Be sure to discard any dark or discolored spots. Turn to speed 4. Mix for about 2 minutes. Scrape bowl with rubber spatula and turn to speed 4 for another 2 minutes, until sweet potatoes are completely mashed.

Separate the eggs. Place the whites in a separate mixing bowl and add the yolks one at a time to the sweet potatoes with the stand mixer running on speed 2. Add the remaining ingredients in the order listed mixing on speed 3 until all of the ingredients are completely incorporated.

Transfer sweet potato mixture to a separate large mixing bowl. Wash and dry both the Cuisinart™ mixing bowl and the chef's whisk thoroughly.

Place egg whites in Cuisinart™ mixing bowl. Insert the chef's whisk. Turn to speed 9 for about 30 seconds. Increase to speed 12 until stiff but not dry, just until whites no longer slip when bowl is tilted, about 1½ to 1¾ minutes more. Remove bowl from stand mixer.

Fold the whites into the sweet potato mixture in 3 additions, using a large rubber spatula.

Pour sweet potato mixture into prepared soufflé dish. Bake in preheated 350°F oven for about 45 minutes until the soufflé is lightly browned on top and puffed over the edge of the soufflé dish.

Serve immediately.



## four-cheese *soufflé*

*An exquisite side dish for any special occasion.*

Makes one 8-cup soufflé

- unsalted butter*
- ¼ cup walnuts, toasted and ground*
- ¼ cup pecans, toasted and ground*
- 5 eggs*
- 5 tablespoons unsalted butter*
- ½ cup unbleached, all-purpose flour*
- 1½ cups milk*
- ½ cup packed shredded Gruyère cheese*
- ¼ cup packed grated Parmesan cheese*
- ¼ cup packed shredded mozzarella cheese*
- ¼ cup packed crumbled Gorgonzola cheese*
- ½ teaspoon salt*
- ¼ teaspoon fresh ground pepper*

Preheat oven to 350°F. Butter an eight-cup soufflé dish well and coat with both ground walnuts and ground pecans; set aside.

Separate the eggs, placing the egg whites in the Cuisinart™ mixing bowl, and reserve. Place the egg yolks in a large mixing bowl, whisk until blended and reserve.

Melt butter in a saucepan. Add flour and stir with a wooden spoon until smooth. Cook over medium heat for 2 minutes, stirring occasionally. Pour the milk into saucepan, whisking simultaneously. Whisk until the mixture has a smooth consistency. Continue to heat slowly, whisking occasionally, until the mixture becomes smooth and thick, about 3 to 5 minutes. Stir in cheeses until melted and incorporated. Stir in salt and pepper. Remove from heat and reserve.

Spoon a small amount of the cheese mixture into the yolks, whisking at the same time. Continue whisking all of the cheese into the yolks slowly, until the mixture is homogenous.

Insert the chef's whisk. Turn to speed 6. Beat the egg whites for about 1 minute and then increase to speed 10 until stiff but not dry, just until whites no longer slip when bowl is tilted, about 1 to 1½ minutes more.

Fold the whites into the yolk/cheese mixture in three additions, using a large rubber spatula.

Pour into prepared soufflé dish and bake in the middle of preheated 350°F oven until puffed over the rim of soufflé dish and golden, approximately 40 to 45 minutes.

Serve immediately.



## souffléed potatoes *with brie*

*This is a great side dish to serve with a roasted tenderloin or grilled fillets when entertaining.*

Makes twelve servings

- 3 pounds Yukon Gold or russet potatoes, peeled, cut into ½-inch slices
- 1 teaspoon salt
- 1 teaspoon white vinegar
- 8 green onions, trimmed and chopped
- ¾ cup reduced fat milk
- 2 tablespoons unsalted butter
- 1 teaspoon kosher salt
- 6 ounces Brie, rind removed, cut into cubes
- ½ teaspoon freshly ground white or black pepper
- 3 large eggs, separated
- ½ teaspoon cream of tartar

Preheat oven to 400°F. Lightly butter a shallow 3-quart casserole or baking dish.

Place potatoes in a large saucepan and cover with water by 2 inches. Add 1 teaspoon salt and 1 teaspoon white vinegar. Bring to a boil, then reduce heat and simmer until potatoes are tender when tested with a fork, about 18 to 20 minutes. While the potatoes cook, combine the green onions, milk, butter and 1 teaspoon kosher salt, bring to a simmer, then turn off the heat and let steep (this may also be done in a microwave).

Drain the potatoes and place in the Cuisinart™ mixing bowl. Insert the flat mixing paddle. Turn to speed 4. Set timer and mix for 2 minutes. Scrape bowl and paddle. Set timer for 5 minutes and continue mixing on speed 4. While mixing, add the milk/green onion mixture that has been steeping. When that has been incorporated, add the cubed Brie and pepper. Add the beaten egg yolks, mixing until totally incorporated. Transfer this mixture to a large bowl. Wash and dry the Cuisinart™ mixing bowl thoroughly.

Place egg whites in the Cuisinart™ mixing bowl. Insert the chef's whisk. Add cream of tartar and whip the egg whites, gradually increasing the speed from speed 1 to speed 10. Whip until the egg whites have formed stiff, but not dry peaks.

Stir about ⅓ of the beaten egg whites into the potato mixture to lighten it. Gently fold the remaining whipped egg whites into the potato mixture. Transfer the mixture to the prepared baking dish or casserole. Bake in the preheated 400°F oven for 50 to 60 minutes, until the top is pale golden and the potatoes are puffed. Let stand 5 minutes before serving.



## meatloaf *with mushrooms*

*This meatloaf is certain to become a family favorite. Sliced leftovers make great sandwiches.*

Makes two meatloaves, 8½x4½x2½ inches each, 16 to 20 servings

- cooking spray
- 1½ tablespoons extra virgin olive oil
- 12 ounces mushrooms, chopped or sliced
- 1½ cups chopped onion
- 3-4 cloves garlic, peeled and finely chopped
- 2½ teaspoons thyme
- 2¼ cups fresh breadcrumbs (made from day-old crusty French bread)
- 1 cup milk (whole, reduced fat, lowfat, or fat free)
- 3 large eggs
- 6 tablespoons tomato paste (unsalted if available)
- 3 pounds ground meatloaf mix (1½ pounds ground round, ¾ pound ground pork, ¾ pound ground veal)
- 6 tablespoons chopped fresh parsley
- 1½ teaspoons kosher salt
- ¾ teaspoon freshly ground pepper

Preheat oven to 375°F. Lightly coat two 8½x4½x2½-inch loaf pans\* with cooking spray.

Heat olive oil in a 12-inch skillet over medium heat. When hot, add mushrooms, onion, garlic, and thyme. Cook until mushrooms and onions are softened (onions will become translucent), about 4 to 5 minutes. Remove from heat and let cool.

Place breadcrumbs, milk, eggs, and tomato paste in the Cuisinart™ mixing bowl. Insert flat mixing paddle. Turn to speed 3 and mix for 30 seconds. Add cooled mushroom/onion mixture, mix until combined, 15 to 20 seconds. Add ground meat, parsley, salt, and pepper. Continue to mix on speed 3 until well combined, about 45 seconds.

Transfer mixture to the prepared loaf pans, rounding the top slightly. Bake in preheated 375°F oven for 1 hour; meatloaf is done when internal temperature is 170°F when tested with an instant-read thermometer. Let meatloaf rest 10 minutes before removing from pan slicing.

\*May also be formed into oval loaves and baked in a 13x9x2-inch roasting pan.



## turkey and spinach meatballs

Make these meatballs ahead, roast and keep in the freezer. Reheat in your favorite marinara sauce and serve with pasta for a quick and easy weeknight meal.

Makes about 50 meatballs

- 2 cups fine fresh breadcrumbs
- 3 cups milk (whole or reduced fat)
- 2 cups finely chopped onions
- 3 large eggs
- 1 tablespoon basil
- 1 teaspoon marjoram
- 1 teaspoon oregano
- ½ teaspoon freshly ground nutmeg
- 2 teaspoons kosher salt
- 1 teaspoon freshly ground pepper
- 2½ pounds ground turkey (7% fat)
- 2½ pounds turkey sausage (hot or sweet – may mix), casings removed
- 20 ounces frozen chopped spinach, thawed, squeezed as dry as possible
- ⅔ cup grated Asiago cheese
- ½ cup minced fresh Italian parsley

Place breadcrumbs and milk in the Cuisinart™ mixing bowl. Let stand 10 minutes. Preheat oven to 400°F. Line baking sheets (jelly-roll type) with parchment or foil.

Add onions, eggs, basil, marjoram, oregano, nutmeg, salt, and pepper to mixing bowl. Insert the flat mixing paddle. Mix on speed 2 until well blended, about 1 minute. Add ground turkey, sausage, and spinach. Mix on speed 1 for 1 minute to blend, then increase to speed 3 and mix until completely combined, about 2 minutes. Scrape the bottom and sides of the bowl and paddle. Add the grated cheese and minced parsley, then mix on speed 3 until blended, about 1½ minutes.

Using a ¼-cup measure or a #16 ice cream scoop, portion out meat mixture and shape into balls. Place on prepared baking sheets about 1½ inches apart. Bake meatballs for 20 to 25 minutes, until browned, turning after about 12 minutes of baking. Let cool. Drain fat from juices, discard fat. Juices may be added to marinara sauce to reheat meatballs.

Reheat meatballs in your favorite marinara sauce.



## pizza *rustica*

*A hearty, satisfying meal for either dinner or lunch.*

Makes one 9-inch pie

### Dough/Crust:

- 4 cups unbleached, all-purpose flour
- ½ cup granulated sugar
- 1 teaspoon kosher salt
- ¼ cup unsalted butter, at room temperature, cut into 1-inch pieces
- ¼ cup extra virgin olive oil
- 4 large eggs

### Filling:

- ½ tablespoon olive oil
- 8 ounces Italian sausage, sweet or hot, casings removed
- 10 ounces fresh spinach
- 2 cloves fresh garlic, finely chopped
- 1 15-ounce container ricotta cheese
- 2 large eggs
- 3 large egg yolks
- 16 ounces mozzarella, shredded
- 3 ounces Parmesan cheese, grated
- 4 ounces prosciutto, chopped
- 2 ounces soppressata or hard salami, chopped

### Egg Wash:

- 1 large egg plus 1 tablespoon of water beaten together



### For the dough:

Place the flour, sugar, and salt in the Cuisinart™ mixing bowl. Insert the flat mixing paddle. Turn to speed 2 for about 20 seconds to aerate dry ingredients. Add the butter and continue on speed 2 for 1 minute. Add the olive oil and mix for 30 seconds on the same speed. The butter and olive oil should be well incorporated into the dry ingredients. Add the eggs one at a time. Be sure to incorporate each egg before adding the next. After adding the last egg, mix on speed 3 until the dough comes together as a mass, about 30 to 40 seconds. If the mixture appears slightly dry, add water one tablespoon at a time on speed 2 until the mixture resembles a soft dough. Gather the dough ball and cut in half, forming each half into a disc shape. Wrap each disc and place in refrigerator. Refrigerate for at least 1 hour.

### For the filling:

Place olive oil in a large sauté pan over medium heat. Add the sausage and sauté until golden brown, breaking the sausage into pieces. Add the spinach and garlic and sauté for an additional minute or two, until the spinach is wilted and the garlic is fragrant. Reserve.

Add the ricotta to the Cuisinart™ mixing bowl. Insert the flat mixing paddle. Mix on speed 2. Add eggs and yolks one at a time. Stir in remaining ingredients including the reserved sausage and spinach mixture until all are incorporated.

Preheat oven to 350°F. Roll one dough disc to a round about 16 inches. Carefully transfer to a 9-inch spring-form pan, trimming the dough so that a 1-inch overhang remains. Pour the filling into prepared pan. Roll out second dough disc to a round and place over filling. Cut the top dough to match the existing overhang. Pinch edges together and then crimp to create a decorative edge. Brush the top well with egg wash. Bake until golden brown, about 70 to 75 minutes.

Let stand about 15 to 20 minutes. Release the pan sides, transfer to a cutting board or platter. Cut into pieces and serve.

## basic *white bread*

*A classic white bread, great for sandwiches.*

Makes two loaves, about 1 pound 14 ounces each

cooking spray  
2½ cups warm (105-110°F) water  
2½ tablespoons honey  
3 teaspoons active dry yeast  
8½ cups bread or unbleached,  
all-purpose flour, divided  
¾ cup nonfat dry powdered milk  
6 tablespoons unsalted butter, at  
room temperature  
3 teaspoons salt

Place warm water, honey, and yeast in the Cuisinart™ mixing bowl. Let stand 5 to 10 minutes until mixture is foamy and bubbly. While yeast is proofing, combine 7½ cups bread flour with powdered milk and salt. Add the flour mixture to the yeast mixture with the unsalted butter. Insert the dough hook and mix on speed 2 for 2 minutes.

Continuing on speed 2, add the remaining flour one tablespoon at a time until a dough ball forms that clings to the dough hook and cleans the sides of the bowl. Set the timer for 4 minutes and the speed to 3 to allow the dough to knead. Transfer the dough to a clean bowl, cover with plastic wrap and let rise in a warm, draft-free place until volume is doubled.

Lightly coat two 9x5x3-inch loaf pans with unsalted butter or cooking spray. Punch dough to deflate. Divide into 2 equal portions. Shape into loaves and place in prepared pans. Cover and let rise until nearly doubled. About 15 minutes before baking, preheat oven to 375°F. Place loaves in preheated oven and bake for 35 to 40 minutes, until bread is browned and sounds hollow when tapped. Remove from loaf pans and cool on a wire rack. Bread slices best when allowed to cool completely before cutting. If top of bread is too crispy for your taste, brush with butter for a softer crust.



## molasses *wheat bread*

*A hearty wheat bread lightly flavored with molasses.*

Makes two loaves, about 1 pound 15 ounces each

- 2½ cups warm (105-110°F) water
- 2½ tablespoons molasses
- 3½ teaspoons active dry yeast
- 5⅓ cups whole wheat flour, divided
- 3⅓ cups or unbleached, all-purpose or bread flour, divided
- ¾ cup nonfat dry powdered milk
- 6 tablespoons unsalted butter, at room temperature
- 1 tablespoon salt

Place warm water, molasses, and yeast in the Cuisinart™ mixing bowl. Let stand 5 to 10 minutes until mixture is foamy and bubbly. While yeast is proofing, combine 5 cups whole wheat flour and 3 cups bread flour with powdered milk and salt. Add the flour mixture to the yeast mixture with the unsalted butter. Insert the dough hook and mix on speed 2 for 2 minutes. Combine remaining flours and reserve.

Continuing on speed 2, add the combined remaining flour one tablespoon at a time until a dough ball forms that clings to the dough hook and cleans the sides of the bowl. Set the timer for 4 minutes and the speed to 3 to allow the dough to knead. Transfer the dough to a clean bowl, cover with plastic wrap and let rise in a warm, draft-free place until volume is doubled.

Lightly coat two 9x5x3-inch loaf pans with unsalted butter or cooking spray. Punch dough to deflate. Divide into 2 equal portions. Shape into loaves and place in prepared pans. Cover and let rise until nearly doubled. About 15 minutes before baking, preheat oven to 375°F. Place loaves in preheated oven and bake for 35 to 40 minutes, until bread is browned and sounds hollow when tapped. Remove from loaf pans and cool on a wire rack. Bread slices best when allowed to cool completely before cutting. If top of bread is too crispy for your taste, brush with butter for a softer crust.



## crusty french bread

*If you have time, allow a second rise before shaping to develop more flavor in the bread, but it is very good without it, too.*

Makes three loaves, about 1 pound each

- 1¼ cups warm (105-110°F) warm water
- 4 teaspoons active dry yeast
- 6¼ cups unbleached, all-purpose or bread flour
- 1¾ cups cake flour
- ¾ cup wheat germ
- 3½ teaspoons fine sea salt
- 1½ cups cold water
- extra flour for dusting bread

Place the warm water in the Cuisinart™ mixing bowl. Stir in yeast and a tablespoon of the flour; let stand for 5 minutes, until mixture is foamy and bubbly. While yeast is proofing, combine 5¾ cups of all-purpose flour and 1¼ cups of cake flour with the wheat germ and salt. Add the cold water and the flour mixture to the yeast mixture. Insert the dough hook and mix on speed 2 for 2 minutes. Combine remaining flours and reserve.

Continuing on speed 2, add the remaining flour mixture 1 tablespoon at a time until a dough ball forms that clings to the dough hook and cleans the sides of the bowl. Set the timer for 4 minutes and the speed to 3 to allow the dough to knead.

Dust dough ball lightly with flour and place in a large bowl, cover with plastic wrap. Let rise in a warm, draft-free place until doubled in size, about 1 hour. Punch dough down, recover, and let rise again until doubled in size. (This last rise can be omitted if pressed for time, but makes for a more flavorful loaf, with a more artisanal bread texture and crust.) Punch dough down and divide into 3 pieces. Shape each into a long narrow loaf, about 14 to 16 inches in length, and place on a baking sheet lined with parchment. Cover loosely with plastic wrap and let rise until doubled, about 45 to 60 minutes. Preheat oven to 425°F.

Dust loaves generously with flour. Make 4 or 5 diagonal slashes in the top of each loaf about ¼-inch deep, using a serrated knife, razor or lame. Bake in preheated 425°F oven 25 to 30 minutes until browned and hollow sounding when tapped. Cool on a wire rack. Bread slices best when allowed to cool completely before slicing.



## cranberry walnut *pumpernickel bread*

*This bread makes a great sandwich with sliced turkey and havarti, or try it toasted topped with creamy Brie.*

Make two loaves, 1¾ pounds each

- 1¾ cups warm (105-110°F) water
- ⅓ cup molasses
- 4 teaspoons active dry yeast
- 4 to 4⅓ cups bread flour, divided
- ⅓ cup yellow cornmeal
- ⅓ cup rye flour
- ⅓ cup whole wheat flour
- ¼ cup unsweetened cocoa powder
- 3 tablespoons vital wheat gluten
- 1 tablespoon instant espresso powder
- 2 teaspoons salt
- 1⅓ cups dried cranberries
- 1⅓ cups walnuts
- 2 tablespoons + 2 teaspoons walnut oil or flavorless vegetable oil
- cornmeal for dusting the pan
- flour for dusting the bread

Place warm water, molasses and yeast in the Cuisinart™ mixing bowl. Let stand 5 to 10 minutes until mixture is foamy and bubbly.

While yeast is proofing, combine 3½ cups of bread flour with the whole-wheat flour, cornmeal, rye flour, cocoa powder, vital wheat gluten, espresso powder, and salt. Add the flour mixture to the yeast mixture. Insert the dough hook and mix on speed 2 for 2 minutes. Add the cranberries, walnuts and oil and mix on speed 3 for an additional 2 minutes.

Continuing on speed 3, add the remaining flour 1 tablespoon at a time until a dough ball forms that clings to the dough hook and cleans the sides of the bowl. Set the timer for 4 minutes to allow the dough to knead. Transfer to a large bowl, cover with plastic wrap and allow to rise in a warm, draft-free place, until doubled in size, about 1 to 2 hours.

Divide dough into 2 equal pieces (about 1 pound 15 ounces each). Shape each into a loaf 10 inches long by 3 inches wide. Line a baking sheet with parchment and dust with cornmeal. Arrange the loaves equally spaced on baking sheet. Dust lightly with flour. Cover with plastic wrap and let rise until about doubled. While loaves are rising, preheat oven to 350°F. Cut 4 diagonal slashes about ⅛-inch deep in the top of in each loaf, using a serrated knife, razor blade or lame. Bake for 55 to 60 minutes, until bread sounds hollow when tapped and registers 205°F when tested with an instant-read thermometer. Transfer to a wire rack to cool. Bread slices best when completely cooled.



## mixed grain, seed *and nut bread*

*Seeds and nuts add to the nutritional value of this delicious bread.*

Makes 2 loaves, about 1¾ pounds each

cooking spray or unsalted butter  
2½ cups warm (105-110°F) water  
1½ tablespoons molasses  
3½ teaspoons active dry yeast  
5¼ cups whole wheat flour  
3 cups bread flour, divided  
¾ cup regular oats  
2½ tablespoons vital wheat gluten  
1 tablespoon salt  
3 tablespoons flax seed oil or walnut oil  
3 tablespoons flax seeds  
3 tablespoons poppy seeds  
3 tablespoons hulled pumpkin seeds, toasted  
3 tablespoons sesame seeds  
3 tablespoons roasted unsalted sunflower seeds  
1 cup slivered almonds or other roughly chopped nuts – optional  
cooking spray or unsalted butter for the pans

Place warm water, molasses and yeast in the Cuisinart™ mixing bowl. Let stand 5 to 10 minutes until mixture is foamy and bubbly.

While yeast is proofing, combine 4¾ cups of whole-wheat flour with 2½ cups bread flour, oats, vital wheat gluten, and salt. Add the flour mixture to the yeast mixture. Insert the dough hook and mix on speed 2 for 2 minutes. Combine remaining flours and reserve.

Add the oil, flax seeds, poppy seeds, pumpkin seeds, sesame seeds, sunflower seeds, and optional nuts. Mix for an additional 2 minutes on speed 3. Continuing on speed 3, add the remaining flour 1 tablespoon at a time until a dough ball forms that clings to the dough hook and cleans the sides of the bowl. Set the timer for 4 minutes to allow the dough to knead. Transfer to a clean bowl, cover and let rise in a warm, draft-free place until volume is doubled, about 1 to 1½ hours.

Lightly coat two 9x5x3-inch loaf pans with unsalted butter or cooking spray. Divide dough into 2 equal pieces and shape into loaves. Place in prepared pans, cover and let rise until dough comes up over the top of the pan by about ¾ inch. While dough is rising, preheat oven to 375°F.

Bake loaves for 35 to 45 minutes, until lightly browned and hollow sounding when tapped. Remove from pans and let cool on a wire rack. Bread slices best when allowed to cool completely before slicing.



## sun-dried tomato *and basil bread*

*This is probably the easiest yeast bread you will ever make – no shaping necessary.*

Makes two loaves, 9x5x3 inches, 1½ pounds each

- cooking spray*
- 4½ *teaspoons active dry yeast*
- ½ *cup warm (105-110°F) water*
- 2 *cups lowfat cottage cheese*
- 2 *large eggs*
- 6 *tablespoons minced sun-dried tomatoes (dry, not oil-packed)*
- ¼ *cup granulated sugar*
- 2 *tablespoons extra virgin olive oil*
- 4 *teaspoons dry basil*
- 4 *teaspoons kosher salt*
- ½ *teaspoon baking soda*
- 5 *cups unbleached, all-purpose flour*

Stir yeast into warm water in a small bowl with a pinch of the flour; let stand 5 minutes until bubbly.

Place cottage cheese, eggs, sun-dried tomatoes, sugar, olive oil, basil, salt, and baking soda in Cuisinart™ mixing bowl. Insert the flat mixing paddle. Turn to speed 2 and mix for 30 seconds, then increase to speed 5 and mix for 1 minute; scrape mixing bowl.

Add yeast mixture and flour. Turn to speed 1 and mix for 30 seconds, then increase to speed 3 and mix for 2 minutes. Scrape bowl and paddle. Leaving dough in mixing bowl, lower mixer arm. Cover with plastic wrap and let dough rise until doubled, about 1 to 1½ hours.

Lightly coat two 9x5x3-inch loaf pans with cooking spray. Turn to speed 1 and stir dough to deflate, 30 seconds. Transfer dough to prepared pan and spread evenly, smoothing over the top. Cover with plastic wrap and let rise until the dough reaches the top of the pans, about 1 hour. Fifteen minutes before baking, preheat oven to 350°F.

Remove plastic wrap and place bread in oven. Bake for 30 to 35 minutes, until bread is browned and sounds hollow when tapped. Transfer to a wire rack to cool. For best slices, allow loaves to cool before slicing.



## buttery dinner rolls

The classic dinner roll we all remember from Sunday or holiday dinners.

Makes 32 dinner rolls

- 1½ cups whole milk
- 1 cup unsalted butter  
(cut into 16 pieces)
- ½ cup granulated sugar
- 2 teaspoons salt
- ½ cup warm (105-110°F) water
- 4 teaspoons active dry yeast
- 2 large eggs
- 8½ to 9½ cups bread flour  
(measure out 1 cup and reserve)
- 2 tablespoons whole milk
- 2 tablespoons unsalted butter

Scald milk (heat until just bubbling around edges – may be done in microwave). Stir in unsalted butter, sugar, and salt. Let cool until just warm (105–115°F).

Place warm water and yeast in the Cuisinart™ mixing bowl with a pinch of the flour. Insert the dough hook and press Fold 2 to 3 times to mix. Let stand until foamy, about 5 minutes. Add the cooled milk mixture, egg and 7½ cups of the flour. Mix on speed 2 for 2 minutes.

Continuing on speed 2, add the remaining flour 1 tablespoon at a time until a loose dough ball forms that clings to the dough hook and cleans the sides of the bowl. Set the timer for 4 minutes and the speed to 3 to allow the dough to knead. Transfer to a medium-large bowl and cover with plastic wrap (may also be put into a 1-gallon resealable food storage bag). Place in a warm, draft-free place and let rise until doubled, about 45 to 60 minutes.

Preheat oven to 375°F. Lightly butter two 10-inch round baking pans. Punch dough to deflate. Divide the dough into 32 equal pieces (each about 2¼ ounces). Roll into balls and arrange in the prepared pans. Cover with plastic wrap and let rise until about doubled, about 30 to 40 minutes. Combine the remaining milk and butter, and heat until butter is melted. Just before baking, gently brush rolls with melted butter and milk. Bake in preheated 375°F oven until golden brown, about 28 to 35 minutes (internal temperature of rolls will be 205°F when tested with an instant-read thermometer). Remove from pans and let cool on a wire rack for about 10 minutes before serving. For softer Buttery Dinner Rolls, brush each with melted butter just after removing from oven.



## basic dough *for pizza, focaccia or calzones*

*Choose your favorite topping or filling!*

Makes about 3 pounds of dough

- 2 cups warm (105-110°F) water
- 3 teaspoons active dry yeast
- 1½ teaspoons honey
- 5 to 6½ cups bread flour, divided
- 3 teaspoons kosher or sea salt
- 3 tablespoons extra virgin olive oil, oil for the bowl

Place water, yeast and honey in the Cuisinart™ mixing bowl and stir to blend. Let stand for 5 minutes, until foamy. In a medium bowl, combine 5½ cups of the flour with the salt. Reserve the additional 1 cup of flour.

Insert the dough hook. Add the olive oil and the 5-cup flour/salt mixture to the yeast mixture. Mix on speed 2 for 2 minutes.

Continuing on speed 2 add the remaining flour 1 tablespoon at a time until a dough ball forms that clings to the dough hook and cleans the sides of the bowl. Set the timer for 4 minutes and the speed to 3 to allow the dough to knead. Transfer the dough to a large bowl that has been lightly coated with olive oil. Turn to coat and cover tightly with plastic wrap. Let rise in a warm, draft-free place until doubled in size, about 1 hour.

Punch dough to deflate and let rest for 10 minutes. If time permits, allow dough to rise a second time for a more developed flavor and texture. Use for your favorite pizza, focaccia or calzones.

Dough can be made a day ahead. Place in a resealable bag and refrigerate. When ready to prepare, punch down dough and allow it to come to room temperature before continuing.



## grape tomato *and herb focaccia*

Serve focaccia as a snack, or as to accompany soup or salad. Omit the tomatoes to make it plain or with just an herb or herb and cheese topping. Slice horizontally and use to make sandwiches.

Makes three 9- or 10-inch focaccias

- 3 cups halved grape tomatoes (may use red, yellow or combination)
- 1½ teaspoons kosher salt
- 1 recipe Basic Dough for Pizza, Focaccia or Calzones, after first (or second) rising (page 20)
- 6 tablespoons extra virgin olive oil, divided
- 1 tablespoon herbes de Provence, Italian herb blend, or basil
- 6 tablespoons freshly grated Parmesan or Asiago cheese
- chopped fresh herbs (optional garnish)

Toss tomatoes in kosher salt and let stand for 15 minutes or longer. Arrange in a single layer on a triple thickness of paper towels to drain. This helps remove excess liquid from the tomatoes.

Preheat oven to 425°F. (If using a baking stone, place in oven before preheating.) Preheat oven for about 1 hour before baking.

Punch dough to deflate. Divide into 3 equal pieces. Let rest 10 minutes before continuing. After 10 minutes, on a lightly floured or cornmeal-dusted work surface, roll each piece of dough into a 9- to 10-inch round or an 8x11-inch rectangle. Place on baking sheet lined with parchment and dusted with cornmeal, or on baker's peel dusted with cornmeal (if using baking stone). Lightly press the tomatoes into the dough, cut side up. Let rise for about 30 minutes. Gently press in any tomatoes that may have loosened. Drizzle each focaccia with 2 tablespoons of olive oil and sprinkle with ½ tablespoon herbs of choice. Sprinkle each evenly with 2 tablespoons grated cheese.

Place focaccias in preheated 425°F oven and bake for 16 to 20 minutes.

Cool on a wire rack for 5 minutes before cutting. If desired, sprinkle with chopped fresh herbs while warm. Serve warm or at room temperature.



## parmesan herb knots

*These soft rolls are great to serve along with soups. They can also be sliced to hold a hamburger or your favorite sandwich combination.*

Makes 24 rolls

- 1 tablespoon granulated sugar
- 4 teaspoons active dry yeast
- 1 cup warm (105-110°F) water
- 1¼ cups cool (70°F) water
- ½ cup fat free powdered milk
- ½ cup potato flakes (instant mashed potatoes, unflavored)
- ¼ cup extra virgin olive oil
- 1½ teaspoons salt
- 6½ to 7 cups unbleached, all-purpose flour
- ¾ cup freshly grated Parmesan cheese
- ⅓ cup extra virgin olive oil
- 1 tablespoon Italian seasoning
- ¼ cup freshly grated Parmesan cheese (optional)

Combine the granulated sugar, yeast and 1 cup warm water in the Cuisinart™ mixing bowl. Stir and let stand 5 minutes to proof.

Insert the dough hook. Add the 1¼ cups of cool water, powdered milk, potato flakes, ¼ cup olive oil, salt and 5 ¾ cups of flour to the yeast mixture. Mix on speed 2 for 2 minutes.

Add the Parmesan cheese and turn to speed 3. Mix until completely incorporated. Add the remaining flour, 1 tablespoon at a time, if necessary until a soft, smooth dough ball is formed. Set the timer for 4 minutes and the speed to 3 to allow the dough to knead.

Transfer to a bowl that has been lightly coated with olive oil. Turn to coat dough and cover with plastic wrap. Place in a warm, draft-free place to rise until doubled in size, about 1 hour. (May also let rise in a 2-gallon resealable freezer weight plastic bag.) Combine ⅓ cup olive oil and Italian seasoning and let stand while dough rises. Line 2 baking sheets with parchment paper.

Punch dough to deflate and divide into 24 equal portions (about 2¼ ounces each). Roll each into a 12-inch rope and tie into a knot. Place on prepared baking sheet, cover loosely with plastic wrap and let rise until doubled, about 35 to 45 minutes. Twenty to thirty minutes before baking, preheat oven to 350°F. Brush lightly with herbed olive oil mixture. If desired, sprinkle each with ½ teaspoon of the optional Parmesan cheese. Place in preheated 350°F oven and bake until lightly browned, about 15 to 18 minutes, rotating the baking sheets after about 7 minutes. Brush knots lightly with reserved olive oil mixture. Transfer to a wire rack and let cool 5 to 10 minutes before serving.



## classic brioche

Making brioche is a two-day process, but well worth the wait – besides, the stand mixer does the hard part.

Makes 36 individual 3 to 3½-inch brioches, or three 8-inch (about 1 pound) brioches à tête  
or two 8½x4½x2½-inch loaves

### For the Sponge:

- ½ cup warm whole milk
- 3½ teaspoons active dry yeast
- 1 large egg + 1 large egg yolk
- 3 cups unbleached, all-purpose flour

### To complete the dough:

- ½ cup granulated sugar
- 7 large eggs + 3 egg yolks, lightly beaten – at room temperature (but liquid)
- 1½ teaspoon kosher salt
- 3 to 3¼ cups unbleached, all-purpose flour
- 1¼ cups unsalted butter, at room temperature, cut into tablespoons

### Egg Wash:

- 2 large eggs, beaten until smooth

To make the sponge, place the warm milk, yeast, egg, egg yolk, and 1¾ cups of the flour in the Cuisinart™ mixing bowl. Insert the flat mixing paddle. Mix until smooth on speed 2, about 1 minute. Scrape the bowl and paddle and remove paddle. Cover the batter evenly with the remaining 1¼ cups of flour. Let stand for 30 to 45 minutes; the mixture will rise and cause the flour to appear cracked. This is normal and lets you know that the mixture is “alive.”

Insert the dough hook. Add the granulated sugar, eggs, yolks, salt and 1½ cups of the remaining flour to the bowl. Mix on speed 2 for 2 minutes. Scrape the bowl and dough hook. Sprinkle with 1½ cups more flour and mix on speed 5 for 15 minutes. After about 7 to 8 minutes of mixing, the dough should come together, wrap itself around the dough hook, and make a “slapping” sound on the sides of the bowl. If after 7 to 8 minutes of mixing the dough is not doing this, add some of the remaining flour, 1 tablespoon at a time. Keep beating on speed 5, until the dough has been mixing for a full 15 minutes – this will help give the brioche its classic texture.

Reduce the stand mixer to speed 2 and add the room temperature butter about 3 tablespoons at a time, allowing the butter to be incorporated nearly completely after each addition. The dough may appear to “fall apart.” After all the butter has been added, increase the stand mixer to speed 9 and mix for 1 minute. Then reduce to speed 5, set the timer and mix for 5 minutes. The dough will once again make the slapping sound on the bowl.

Transfer the dough to a large well-buttered bowl and cover tightly with plastic wrap. Let rise at room temperature until doubled in volume, about 2 to 2½ hours. When it has risen, deflate by lifting and letting it fall back into the bowl, doing this all around the ball of dough. Cover tightly again with plastic wrap and refrigerate for at least 4 to 6 hours, or overnight, to rise again. After the dough has risen and chilled, it is ready to use – shape while chilled for best results.

For individual brioches (may be made in standard cupcake pans): Butter the pans generously. Divide dough into 36 equal pieces. One at a time, pull off a piece of dough about the size of a ½-inch marble from each of the pieces, and shape into a ball; shape the larger piece of dough into a smooth ball and place in the buttered pan. Make an indentation in the center of the large ball with your finger. Place the small ball in the indentation. Repeat until all are done. Cover loosely and let rise until doubled. Preheat oven to 375°F. When doubled, brush with egg wash – do not let dribble into sides of pan. Bake for 17 to 19 minutes, until they are a rich, deep golden brown, and sound hollow when tapped – baked brioche will register 200°F if tested with an instant-read thermometer. Remove from pan and let cool 10 to 15 minutes on a wire rack before serving, or cool completely to room temperature.

For one-pound brioches, divide dough into 3 equal portions. Place dough in buttered 8" brioche molds. Follow shaping directions as for individual brioche, but smaller ball should be about the size of a golf ball. Follow rising and egg wash instructions. Bake in preheated 375°F oven for 30 to 35 minutes. Remove from pans. Cool on a wire rack completely before slicing.

For one-pound loaves, divide dough into 3 equal portions. Shape into loaves and place in well-buttered 8½x4½x2½-inch loaf pans. Cover and let rise until doubled. Glaze with egg wash. Bake in preheated 375°F oven for 30 to 35 minutes until deep golden brown and hollow sounding when tapped. Remove from pans. Cool completely on a wire rack before slicing.

## moravian *sugar cakes*

A traditional Moravian yeasted "coffee" cake, often served during the Christmas holidays. It can be eaten warm or cold, as a dessert or for breakfast. It also freezes well after baking, making it a nice treat to have on hand to warm up for family and friends.

Makes two 13x9x2½-inch cakes or four 9x9x2½-inch cakes

- 12 ounces russet potatoes, peeled and sliced ½-inch thick
- 2¼ teaspoons (1 packet) active dry yeast
- ½ cup warm water
- 1 cup granulated sugar
- ¼ cup unsalted butter, at room temperature
- ½ cup non-hydrogenated vegetable shortening
- 1 teaspoon salt
- 2 large eggs, well beaten
- 7 cups unbleached, all-purpose flour, sifted
- 1¼ cups unsalted butter, divided
- 1 cup packed brown sugar, divided
- cinnamon (optional)

Place potatoes in a saucepan and cover with water by 1 inch. Bring to a boil over high heat, then reduce heat to a simmer and cook until potatoes are tender and can be mashed. Drain, reserving 1 cup of the potato cooking water, and let cool to lukewarm (no warmer than 110°F). Mash potatoes (do not add any liquid or seasoning) and measure out 1 cup to use to prepare the Moravian Sugar Cakes. Let potatoes cool slightly.

Dissolve the yeast in warm water in the Cuisinart™ mixing bowl. Insert the flat mixing paddle. Add mashed potatoes, granulated sugar, 2 tablespoons butter, shortening and salt. Mix on speed 1 until smooth and creamy. When lukewarm, add potato water to the yeast mixture. Stir on speed 1 until well blended, about 2 minutes. Lift paddle up from mixer. Cover mixing bowl with plastic wrap and let the mixture rise until "spongy" in appearance, about 1 to 2 hours.

After dough has risen, while mixing on speed 3, add eggs one at a time. Scrape bowl and paddle. Add 2 cups of the flour and mix on speed 3. When completely mixed in, scrape bowl and paddle. Remove flat mixing paddle and insert dough hook. Add remaining flour ½ cup at a time. This will be a very soft dough. Transfer to a buttered bowl, cover and let rise until double in volume. Punch down and divide dough in half. Lightly butter two 13x9x2½-inch pans or four 9x9x2½-inch pans.

Spread dough evenly prepared pans. Cover with plastic wrap. Let rise until double in volume. Preheat oven to 375°F.

Use fingertips to make holes about ¾ inches apart in rows evenly across the dough. Brush generously with the melted butter. Fill finger holes with dots of butter and sprinkle brown sugar evenly over the top. Dust with cinnamon if desired.

Bake at 375°F for 20 to 30 minutes. Remove cakes from pans and cool slightly on wire racks. Serve warm for best flavor. Cakes may be frozen (double wrapping suggested) after baking.



## cinnamon *swirl buns*

These cinnamon swirl buns are the BEST!

Makes 30 buns

cooking spray

Buns:

- $\frac{3}{4}$  cup warm (105-110°F) milk
- 4 teaspoons active dry yeast
- $\frac{3}{4}$  cup granulated sugar
- $\frac{1}{2}$  cup sour cream, at room temperature
- $\frac{1}{2}$  cup unsalted butter, at room temperature
- 4 large eggs, at room temperature
- 1 teaspoon salt
- 8 cups unbleached, all-purpose flour, divided
- $\frac{2}{3}$  cup packed brown sugar
- $\frac{1}{3}$  cup granulated sugar
- 3 tablespoons cinnamon
- 6 tablespoons unsalted butter – at room temperature, very soft

Cream Cheese Frosting (makes 2 cups):

- 6 ounces lowfat cream cheese, at room temperature
- 6 tablespoons unsalted butter, at room temperature
- 1 tablespoon milk
- 2 teaspoons pure vanilla extract
- $1\frac{1}{2}$  cups powdered sugar, sifted

Note: If you wish to have warm, fresh Cinnamon Swirl Buns in the morning, dough may be mixed, allowed to have its first rise, and shaped the night before. If doing the night before, place covered pans in the refrigerator to rise. Remove from refrigerator and let stand at room temperature one hour before baking.

If you wish to freeze Cinnamon Swirl Buns after baking, do not frost. Re-warm in a conventional oven (microwaving is not recommended) and frost before serving.

Place warm milk and yeast in Cuisinart™ mixing bowl with a pinch of the sugar and stir. Let stand until foamy, about 5 to 10 minutes. Insert the flat mixing paddle. Add the remaining sugar, sour cream, butter, and eggs. Mix on speed 1 for 1 minute. Add salt and 3 cups of the flour. Mix on speed 1 until smooth, 1 to 2 minutes. Scrape the bowl and paddle.

Remove the flat mixing paddle and insert the dough hook. Remove and reserve  $\frac{1}{2}$  cup of remaining flour. While mixing on speed 2 add the larger portion of flour,  $\frac{1}{3}$  cup at a time, allowing the flour to be almost totally incorporated before each addition. If dough is too sticky or does not form a “loose” ball that cleans the sides of the bowl, add enough of the remaining flour, 1 tablespoon at a time until it does. With the mixer on speed 3, set the timer for 8 minutes to knead the dough. Transfer to a large bowl and cover with plastic wrap. Place in a warm, draft-free place and let rise until doubled in volume, about 60 to 90 minutes. Place the brown sugar, granulated sugar and cinnamon in a small bowl and stir to combine.

Punch dough down to deflate. Divide the dough into 2 equal pieces and let rest 10 minutes before continuing. Lightly coat two 13x9x2-inch baking pans with cooking spray. Flatten each portion of dough into rectangles about 20 inches long and 10 inches wide. Spread each with softened butter within  $\frac{1}{2}$  inch of one long side and to the edge of all the others. Sprinkle each evenly with half the sugar/cinnamon mixture. Roll as for a jelly roll, ending with the unbuttered side. Pinch along long side to seal. Cut each with a serrated knife into 15 equal portions. Arrange 15 cinnamon buns in each of the two prepared pans. Cover with plastic wrap and let rise until nearly doubled in volume. (See Note.) Fifteen minutes before baking, preheat oven to 350°F.

Bake Cinnamon Swirl Buns for 25 to 35 minutes, until puffed with golden tops, and hollow sounding when tapped. While baking, place the cream cheese and butter in the Cuisinart™ mixing bowl. Insert the flat mixing paddle, and whip the cream cheese and butter on speed 8 until smooth, creamy and fluffy, about 1 minute. Scrape the bowl and whisk. Add vanilla and milk and whisk on speed 8 until blended. Add half the powdered sugar. Stir on speed 1 until sugar is incorporated. Add remaining powdered sugar and stir on speed 1 until incorporated. Mix on speed 8 for 1 minute until light and fluffy.

Spread about 1 tablespoon of Cream Cheese Frosting on each warm Cinnamon Swirl Bun. There will be a little extra frosting for those who like more. Serve.

## banana bran muffins

*These muffins are so tasty, it is hard to believe they are good for you too!*

Makes 24 muffins

- cooking spray*
- 1 *cup whole wheat flour*
- 1 *cup unbleached, all-purpose flour*
- 1½ *cups oat bran*
- 1½ *cups wheat bran*
- 1 *tablespoon plus 1 teaspoon baking powder*
- 1 *teaspoon salt*
- 2 *cups buttermilk*
- ½ *cup brewed coffee*
- 2 *large eggs*
- 2 *teaspoons pure vanilla extract*
- ¼ *cup flax seed oil*
- ½ *cup molasses*
- ½ *cup applesauce*
- 1 *cup mashed banana (about 2 bananas)*

Place flours, brans, baking powder, and salt in the Cuisinart™ mixing bowl. Insert the flat mixing paddle. Turn to speed 2. Mix for 20 seconds to incorporate all dry ingredients. With the stand mixer running on speed 2, pour the buttermilk and coffee in together followed by the eggs, vanilla, and oil. Mix on speed 2 for about 30 seconds, until incorporated. Scrape the paddle and mixing bowl with a rubber spatula. With stand mixer running on speed 2, add the molasses and applesauce and mix for 15 seconds. Scrape the bowl. Add the banana and mix on speed 2 for 15 seconds to incorporate.

Pour the batter into a clean mixing bowl and cover with plastic wrap and refrigerate for at least 12 hours.

When ready to bake, preheat oven to 400°F. Spray two 12-cup muffin tins with cooking spray. Divide the batter evenly among the cups, about ¼ cup of batter per muffin.

Bake for 20 to 25 minutes, turning tray once halfway through baking. Remove muffins from tin and allow to cool on a wire rack.



## three-berry *muffins*

*A delicious muffin, perfect when fresh fruit is ripe in the summertime!*

Makes 24 muffins

- cooking spray*
- 4 *cups unbleached, all-purpose flour*
- 1 *tablespoon plus 1 teaspoon baking powder*
- 1 *teaspoon salt*
- 1 *teaspoon cinnamon*
- ½ *cup unsalted butter, melted*
- 1 *cup packed light brown sugar*
- 1 *cup sour cream*
- 2 *large eggs*
- 2 *teaspoons pure vanilla extract*
- ½ *cup milk*
- 2 *cups mixed berries: blueberries, strawberries, and raspberries, fresh or frozen*
- granulated sugar for dusting*

Preheat oven to 400°F. Thoroughly spray two 12-cup muffin tins.

Place flour, baking powder, salt, and cinnamon in a small bowl and stir; reserve.

Place the melted butter and brown sugar in the Cuisinart™ mixing bowl. Insert the flat mixing paddle. Turn to speed 2 and mix for 30 seconds until incorporated. Reduce to speed 1 and add the sour cream, then increase to speed 3 for 30 seconds. Stop, scrape paddle and bowl well and add the eggs, vanilla, and milk. Turn to speed 3 and mix for 30 to 40 seconds until well incorporated. Stop and scrape the paddle and bowl well. Sprinkle the flour mixture evenly over the wet ingredients. Press the Fold button to carefully incorporate the flour, about 15 times. Add the berries and very carefully fold them in until they are just blended in.

Scoop even amounts (¼ cup each) of batter into the prepared muffin tins. Sprinkle the tops of the muffins liberally with granulated sugar.

Bake in preheated 400°F oven until tops are golden and a cake tester comes out clean, approximately 20 to 25 minutes. Remove muffins from tins and allow to cool on a wire rack.



## oatmeal *pear crumb muffins*

*These crumb-topped muffins may also be made with diced apple or mango.*

Makes 24 muffins

cooking spray

### Crumb Topping:

1½ cup unbleached, all-purpose flour

1 cup packed brown sugar

16 tablespoons unsalted butter,  
at room temperature,  
cut into 8 pieces

1½ teaspoons cinnamon

½ teaspoon ginger

### Muffins:

2 cups regular oats

1½ cups packed brown sugar

1 cup lowfat milk

2 cups all-purpose flour

4 teaspoons baking powder

1 teaspoon cinnamon

½ teaspoon ginger

½ teaspoon salt

½ cup unsalted butter, melted and  
cooled

2 large eggs

2 cups diced (¼-inch) fresh pear  
(may also use diced apple  
or mango)

1 cup chopped walnuts

Lightly coat two 12-cup muffin tins with cooking spray; reserve. Preheat oven to 400°F.

To prepare crumb topping, place flour, brown sugar, butter, cinnamon and ginger in the Cuisinart™ mixing bowl. Insert flat mixing paddle. Turn to speed 1 and mix for 15 seconds, then for 30 to 40 seconds on Speed 2, until large crumbs form; remove and reserve in refrigerator.

To prepare the muffins, place the oats, brown sugar, and milk in Cuisinart™ mixing bowl. Insert flat mixing paddle. Turn to speed 1 and mix for 30 seconds, then let stand for 10 minutes to soften the oats. Place the flour, baking powder, cinnamon, ginger and salt in a small bowl and stir; reserve. Add melted and cooled butter to softened oat mixture. Turn to speed 2 and mix for 20 seconds. Add eggs and mix on speed 1 for 20 seconds. Scrape the bottom and sides of mixing bowl. Add the reserved dry mixture, diced pear and walnuts. Press the Fold button about 5 to 10 times to blend flour mixture into wet ingredients until all flour has “disappeared”, taking care not to over-mix.

Divide batter evenly among prepared muffin cups. Evenly sprinkle the top of each with crumb topping. Bake in preheated 400°F oven for 15 to 20 minutes until puffed, crumb topping is golden, and a cake tester is clean when inserted in center. Cool for 3 to 5 minutes in pan, then loosen and gently turn muffins out onto a wire rack to cool completely. May be served warm or cooled.



## vanilla yogurt scones

*This soft, moist dough makes delicious and light scones. We made ours plain, but you may add dried fruit such as currants, tart cherries or blueberries if you like.*

Makes 16 scones

- 4 large eggs
- 1⅓ cup fat free vanilla yogurt
- 6½ cups unbleached, all-purpose flour
- ½ cup granulated sugar
- 2 tablespoons baking powder
- ½ teaspoon salt
- 1 cup unsalted butter, at room temperature, cut into ½-inch pieces
- 1 large egg white, beaten with a fork until frothy
- 4 teaspoons granulated sugar
- 1 teaspoon cinnamon

Preheat oven to 400°F. Line baking sheet with parchment. Beat eggs until smooth with a fork or whisk. Stir in yogurt and reserve.

Place flour, sugar, baking powder and salt in the Cuisinart™ mixing bowl. Insert flat mixing paddle. Stir on speed 1 for 15 to 20 seconds. Add butter and mix until flour mixture is slightly crumbly, about 1 minute. Add yogurt/egg mixture and mix on speed 1 for 30 to 40 seconds. Scrape the bowl and paddle, and mix until just blended on speed 1. Do not over-mix. Dough will be soft and slightly sticky.

Turn out onto lightly floured surface. This dough will be somewhat sticky. Knead with floured hands 4 times. (Flatten, fold, repeat 4 times.) Divide into 4 equal parts; flatten into four 5- to 6-inch rounds. Use a serrated knife or pizza cutter to cut each into 4 wedges. Arrange on prepared baking sheet, with the wedges about 1 inch apart. Brush with egg white. Mix the 4 teaspoons of sugar with the cinnamon and sprinkle on wedges.

Bake for 20 minutes in preheated 400°F oven. Cool on a wire rack 5 minutes before serving.

Notes:

You may add ⅓ to ½ cup dried fruits such as dried blueberries, cherries, raspberries, chopped apricots, dried chopped mango, or currants.



## almond shortcakes *with fresh berries, stone fruits and sweetened whipped cream*

An updated version of the traditional summertime favorite. You may also serve this with plain strawberries.

Makes 12 shortcakes

### Fresh Berry & Stone Fruit Filling:

- 1 cup sliced/quartered strawberries
- 1 cup blueberries
- 1 cup raspberries
- 2 large peaches, peeled, pitted, cut into ¼-inch slices
- 3 plums, pitted, cut into ¼-inch slices
- 1 cup pitted and halved sweet cherries
- 2 tablespoons fresh lemon juice
- ½ cup sugar

### Sweetened Whipped Cream Topping:

- 1 teaspoon unflavored gelatin
- 2 tablespoons water or liqueur (*Grand Marnier® is very good in this recipe*)
- 2 cups heavy cream
- ½ cup superfine sugar

### Shortcakes:

- 2 cups unbleached, all-purpose flour
- ½ cup almond meal (*finely ground almonds – available in many well stocked grocery stores or specialty food stores*) or ground almonds
- ⅓ cup granulated sugar
- 1 tablespoon baking powder (3 teaspoons)
- ¾ teaspoon salt
- 8 tablespoons cold unsalted butter, cut into ½-inch pieces (*take out of refrigerator 10 minutes before using*)
- 1 cup regular sour cream
- 2 tablespoons milk
- 1 teaspoon pure almond extract
- flour for kneading/rolling
- 1 egg white, beaten until frothy
- 4 teaspoons granulated sugar (*use coarse sugar if available*)

Arrange rack in upper middle of oven. Preheat oven to 425°F. Line a baking sheet with parchment paper.

Place all of the fruit in a large bowl with the lemon juice and ½ cup sugar. Stir gently to combine and allow to macerate at least 30 minutes before serving. May be done ahead and refrigerated – remove from refrigerator 30 minutes before serving.

Sprinkle the gelatin over the water or liqueur and let soften for 5 minutes. Place in a pan of simmering water and heat until completely liquefied; let cool. Place heavy cream, sugar and liquefied gelatin mixture in the Cuisinart™ mixing bowl. Insert the chef's whisk. Turn to speed 6 and mix until slightly thickened, about 30 seconds. Increase to speed 10 and beat until soft peaks form, about 2 minutes. Transfer to a separate bowl, cover and refrigerate until ready to use.

Place the flour, almond meal, ⅓ cup granulated sugar, baking powder, and salt in the Cuisinart™ mixing bowl. Insert the flat mixing paddle. Turn to speed 2 and mix for 30 seconds to combine and aerate. Add butter. Mix on speed 3 for 2 to 3 minutes, until the mixture resembles coarse crumbs, but some of the butter is still visible in the size of small peas. Add sour cream, milk and almond extract; mix on speed 1 until combined – dough will be sticky. Turn out onto a floured surface and turn to coat with flour. With floured hands, knead (flatten, turn, fold) 6 times. Roll out to a ½-inch thickness and cut into rounds using a 2-inch round or square biscuit cutter dipped in flour. Arrange shortcakes evenly spaced on the prepared baking sheet. Brush with the beaten egg whites and sprinkle with the sugar. Bake shortcakes in preheated 425°F oven for 18 to 20 minutes, until puffed, golden, and tops are slightly crackled. Remove from oven and place on a wire rack to cool slightly.

To serve, slice warm shortcakes horizontally and place the bottoms on dessert plates or soup plates. Top each with the macerated fruit and some of the accumulated juices, then a dollop of whipped cream, and the top of the shortcake. Serve immediately.

## buttermilk blueberry *crumb cake*

*This do-ahead coffee cake will be a favorite for brunch.*

Makes two cakes, 9x9x2 inches, 24 servings

cooking spray

### Crumb Topping:

- 2¼ cups unbleached, all-purpose flour
- 1 cup packed brown sugar
- 1 cup unsalted butter, at room temperature, cut into 16 pieces
- 2½ teaspoons cinnamon
- 1 teaspoon pure vanilla extract
- ½ teaspoon salt

### Buttermilk Cake:

- 2⅔ cups unbleached, all-purpose flour
- 1 teaspoon baking soda
- 1 teaspoon cream of tartar
- ½ teaspoon salt
- 1 cup unsalted butter, at room temperature, cut into 16 pieces
- 2 cups granulated sugar
- 3 large eggs, at room temperature
- 1 teaspoon pure vanilla extract
- 1 cup buttermilk
- 3½ cups blueberries, preferably fresh (If using frozen blueberries, thaw in a single layer on layered paper towels, pat dry)

Preheat oven to 350°F. Lightly coat two 9x9x2-inch baking pans with cooking spray; reserve.

To prepare the crumb topping, place the flour, brown sugar, butter, cinnamon, vanilla, and salt in the Cuisinart™ mixing bowl. Insert the flat mixing paddle. Turn to speed 1 and mix for 20 seconds, then increase to speed 3 and mix until the mixture resembles large crumbs, about 40 to 60 seconds. Remove and reserve in refrigerator until ready to use.

To prepare the buttermilk cake, place the flour, baking soda, cream of tartar, and salt in a medium bowl and stir to combine; reserve. Place the butter and granulated sugar in the Cuisinart™ mixing bowl. Insert the flat mixing paddle. Turn to speed 1 and mix for 30 seconds, then increase to speed 4 and mix until light and fluffy, about 1 minute. Add the eggs one at a time and mix on speed 2 until smooth, about 2 minutes total. Scrape the bottom and sides of the mixing bowl; add vanilla and mix on speed 2 for 30 seconds. Add half the reserved dry mixture and half the buttermilk. Turn to speed 1 and mix until blended, about 30 seconds. Scrape the bottom and sides of the mixing bowl. Add remaining dry ingredients and buttermilk. Mix on speed 1 for 30 to 40 seconds longer until smooth and blended.

Divide batter evenly between two prepared pans. Smooth over top. Sprinkle blueberries evenly over the top; lightly press blueberries into batter (submerge blueberries slightly). Crumble any large clumps in the crumb mixture and sprinkle the crumb mixture evenly over the blueberries.

Bake in preheated 350°F oven for 55 to 60 minutes, until crumbs are evenly golden brown and cake tester is clean when inserted in center of pan. Remove from oven and place on wire rack to cool. Cool completely before cutting.



## lemon poppy seed cake

*A delightful cake, perfect for brunch or tea.*

Makes one 2-pound loaf

2¼ cups unbleached, all-purpose flour  
2 teaspoons baking powder  
¼ teaspoon salt  
¾ cup unsalted butter, at room temperature  
1½ cups granulated sugar  
¼ cup lemon juice  
3 teaspoons lemon zest  
3 large eggs  
1 teaspoon pure vanilla extract  
¾ cup milk  
1 tablespoon poppy seeds

Preheat oven to 325°F. Butter and flour a 9x5-inch loaf pan well.

Stir the flour, baking powder, and salt together in a small mixing bowl. Reserve.

Place the butter in the Cuisinart™ mixing bowl. Insert the flat mixing paddle. Turn to speed 1. Cream butter for 30 seconds, then turn to speed 4 for 30 seconds. Scrape both the paddle and bowl well. Reduce to speed 2 and add the sugar. Increase to speed 4 until light and fluffy, about 1 minute. Scrape both the paddle and bowl well. Add the lemon juice and zest and mix on speed 3 to incorporate. With the stand mixer running on speed 2, add the eggs one at a time. Beat each egg smooth before adding the next. Mix in the vanilla. With stand mixer running on speed 2, slowly add the dry ingredients and milk alternately, beginning and ending with the dry ingredients. With the stand mixer running on speed 2, add the poppy seeds. Be sure to fully incorporate ingredients and be careful not to overwork the batter.

Pour batter into prepared loaf pan. Bake in preheated 325°F oven for about 60 to 70 minutes, until a cake tester comes out clean.

Transfer pan to a wire rack to cool. When the pan is cool enough to touch, invert pan onto the wire rack in order to remove the cake. Leave cake right side up on rack until completely cooled. Serve.



## sour cream *cinnamon walnut streusel coffee cake*

An old familiar coffee cake that everyone just loves.

Makes 10-inch Bundt®-type cake, 12 to 16 slices

*unsalted butter for pan*

Streusel:

- 1 cup coarsely chopped walnuts
- ½ cup granulated sugar
- 1 tablespoon cinnamon

Cake:

- 2¼ cups unbleached all-purpose flour
- 1 tablespoon baking powder
- 1 teaspoon baking soda
- ½ teaspoon salt
- ¾ cup unsalted butter, at room temperature, cut into 1-inch pieces
- 1½ cups granulated sugar
- 3 large eggs, at room temperature
- 1½ cups sour cream
- 1 tablespoon pure vanilla extract

Preheat oven to 350°F. Evenly brush a 10-inch (12-cup) Bundt®-type tube pan with 2 tablespoons softened or melted butter. Place walnuts in a small bowl with the ½ cup granulated sugar and 1 tablespoon cinnamon to make the streusel and stir to combine. Reserve.

To make the cake batter, place the flour, baking powder, baking soda, and salt in a medium bowl. Stir well to blend. Reserve.

Place the butter and sugar in the Cuisinart™ mixing bowl. Insert the flat mixing paddle. Turn to speed 4 and mix until soft and light, about 5 minutes, stopping to scrape the bowl and paddle about every 2 minutes. Add the eggs, one at a time, beating until smooth after each egg has been added. Scrape the bowl and paddle. Mix on speed 4 for 30 seconds.

Reduce the stand mixer to speed 1. Add ⅓ of the flour mixture followed by ½ of the sour cream, and the vanilla. Mix 30 seconds. Stop and scrape the bowl and paddle. Add another ⅓ of the flour mixture and the remaining sour cream. Mix for 30 seconds. Stop and scrape the bowl and paddle. Add the remaining flour mixture and mix for 30 seconds. Scrape the paddle and remove the bowl from the stand mixer. Using a large rubber spatula, scrape the bowl and give the batter a quick stir by hand.

Sprinkle about ¼ cup of the streusel into the prepared pan. Top with a scant half of the batter, and sprinkle with about ⅔ of the remaining streusel. Cover with the remaining batter and smooth over the top. Sprinkle with the remaining streusel.

Bake in the preheated 350°F oven for 55 to 60 minutes, until a cake tester comes out clean when inserted midway between the sides of the pan and the inner tube. Cool in the pan on a wire rack for 30 minutes, then turn out on the wire rack and remove the pan to cool.

Let cool completely before slicing. To keep, wrap in plastic wrap. The cake may be double wrapped and frozen to store for a longer period of time.

Variation: Add about ¾ cup mini chocolate morsels to the flour mixture.



## dried cherry *and almond biscotti*

*These biscotti resemble the more traditional dunking biscuit – they have an excellent crunch!*

Makes about 96 small biscotti

- 2¾ cups unbleached, all-purpose flour
- 2 cups granulated sugar
- 1 teaspoon baking powder
- 1 pinch salt
- 3 large eggs
- 2 large yolks
- ½ cup tart dried cherries
- ½ cup almonds, toasted and roughly chopped

Preheat oven to 350°F. Line two baking sheets with parchment paper.

Place the flour, sugar, baking powder, and salt in the Cuisinart™ mixing bowl. Insert the flat mixing paddle. Turn to speed 1 to mix dry ingredients, about 10 seconds. Increase to speed 2, add eggs and then yolks one at a time, allowing each to incorporate before adding the next. Add the cherries and chopped almonds and allow the stand mixer to run until all ingredients are just incorporated. Dough may be wet.

Turn dough out onto a floured surface and divide into four equal pieces. Shape each piece into a rectangular log that is 12x1½x1½ inches. Place 2 logs on each prepped baking sheet and bake in preheated 350°F oven until golden, about 35 minutes. Remove from oven, and when cool to touch, slice each log into about 25 half-inch slices. Bake again in oven on a lower rack until golden, about 30 minutes.

Let cool on baking sheet for 2 to 3 minutes, then transfer biscotti to a wire rack to cool completely. Once cool, store in an airtight container.



## almond thumbprints

A traditional holiday cookie.

Makes about 60 cookies

- $3\frac{3}{4}$  cups unbleached, all-purpose flour
- $1\frac{3}{4}$  cups finely ground almonds or almond meal
- $\frac{3}{4}$  cup + 1 tablespoon confectioners' sugar
- $\frac{3}{4}$  cup + 1 tablespoon granulated sugar, divided
- $1\frac{1}{4}$  teaspoons baking powder
- $\frac{3}{4}$  teaspoon salt
- $3\frac{3}{4}$  sticks unsalted butter, at room temperature
- 2 large eggs
- $1\frac{1}{2}$  teaspoon pure vanilla extract
- $\frac{3}{4}$  cup fruit preserves, warmed

In a mixing bowl, combine the flour, almonds, confectioners' sugar,  $\frac{1}{2}$  cup of the granulated sugar, baking powder and salt. Reserve.

Place the butter in the Cuisinart™ mixing bowl. Insert the flat mixing paddle. Turn to speed 2 to cream butter. After about 10 seconds, increase to speed 4 for an additional 15 seconds. Scrape bowl and paddle. With stand mixer running on speed 2 and add remaining sugar, and then increase to speed 4, until mixture is light and fluffy, about 30 seconds. Scrape bowl and paddle. Turn back to speed 2, add eggs and vanilla and increase to speed 4 for about 15 seconds until incorporated. Scrape bowl and paddle. Turn to speed 1 and slowly pour the flour mixture over the top in two additions. After last addition has been added, increase to speed 3 until just fully incorporated. Be careful not to over-beat.

Transfer the dough to a bowl and cover or place in a resealable plastic bag and refrigerate until firm, about 1 hour or overnight.

Heat oven to 350°F. Line 3 baking sheets with parchment paper.

Roll dough into  $1\frac{1}{4}$ -inch balls. Place the dough balls on the prepared baking sheets 2 inches apart. Make a depression in the center of each cookie with fingertip or the handle of a wooden spoon. Bake cookies for about 10 minutes.

Remove baking sheets from oven. Use the back of a round teaspoon measuring spoon to re-form the depressions in the cookies. Fill each depression with  $\frac{1}{2}$  teaspoon preserves. Continue baking cookies until are they are lightly golden brown around the edges, about 8 minutes longer. Cool on baking sheets for 2 minutes, then transfer to a wire rack to cool completely.

Can be made ahead. Store in airtight container at room temperature between sheets of waxed paper.



## chocolate *cherry crackles*

*Chewy, chocolaty cookies with tart cherries for contrast.*

Makes about 80 cookies

- $\frac{3}{4}$  cup plus 1 tablespoon unsweetened cocoa (preferably Dutch process)
- $2\frac{1}{4}$  cups unbleached, all-purpose flour
- 2 teaspoons baking powder
- $\frac{1}{2}$  teaspoon salt
- $\frac{3}{4}$  cup plus 1 tablespoon unsalted butter, melted
- $2\frac{1}{4}$  cups granulated sugar
- 4 large eggs
- 1 tablespoon pure vanilla extract
- 1 teaspoon pure almond extract
- 1 cup mini chocolate morsels
- 1 cup dried tart cherries
- 1 cup confectioners' sugar, sifted

Place the cocoa, flour, baking powder, and salt in a small bowl. Stir ingredients together with a wooden spoon to aerate and blend dry ingredients.

Place the melted butter and sugar in the Cuisinart™ mixing bowl. Insert the flat mixing paddle. Turn to speed 3. Mix ingredients until smooth, about 30 seconds. With stand mixer running on speed 3, add the eggs, one at a time, beating for 10 seconds after each egg is added, and then add vanilla and almond extracts. Beat until smooth and creamy, about 30 seconds. Scrape bowl and paddle. Press the Fold button to mix in the dry ingredients in 2 additions. Mix until just combined, about 30 seconds. Mix on speed 3 for 1 minute until thick and creamy. Decrease to speed 2. Add chocolate morsels and cherries and mix until just blended, 15 to 20 seconds.

Preheat oven to 350°F. Line baking sheets with parchment or nonstick baking liners. Shape dough into 1-inch balls, coat generously in confectioners' sugar, and arrange on baking sheets 1 inch apart. Bake for about 12 minutes until tops appear crackled. Cool on sheets 2 minutes, then transfer to wire racks to cool completely.



## chocolate chunk *macadamia cookies*

*A chocolate chip cookie with a triple chocolate twist.*

Makes about 80 cookies

- 4½ cups unbleached, all-purpose flour*
- 1½ teaspoons baking soda*
- ¾ teaspoon salt*
- 1½ cups unsalted butter, at room temperature, cut into ½-inch slices*
- 1½ cups light brown sugar, packed*
- 1 cup plus 1 tablespoon granulated sugar*
- 3 large eggs*
- 2 teaspoons pure vanilla extract*
- ¾ cup macadamia nuts, toasted and roughly chopped*
- 6 ounces semisweet chocolate, roughly chopped*
- 6 ounces milk chocolate, roughly chopped*
- 3 ounces white chocolate, roughly chopped*

Place flour, baking soda, and salt in a mixing bowl. Reserve.

Place the butter in the Cuisinart™ mixing bowl. Insert the flat mixing paddle. Turn to speed 2 for about 10 seconds and then increase to speed 4 for an additional 10 to cream the butter. Scrape the bowl and paddle. Turn to speed 2 and add both sugars, increasing speed to 4 for about 15 to 20 seconds. Scrape the bowl and paddle. Add eggs one at a time with the stand mixer running on speed 2, increasing to speed 4 for 15 seconds for to incorporate each egg. Add vanilla. Scrape bowl and paddle. Turn to speed 1; add the dry ingredients in 2 additions. After the last addition, increase to speed 3 until just fully incorporated. With the stand mixer running on speed 2, add the macadamia nuts and all chocolate chunks. Mix for about 20 seconds until all of the ingredients are completely incorporated.

Drop well rounded spoonfuls, about 1½ tablespoons (you may use a #40 ice cream scoop), onto a tray lined with plastic wrap. Cover with plastic wrap or waxed paper and refrigerate for at least 2 hours.

Preheat oven to 350°F 15 to 20 minutes before baking. Line baking sheets with parchment paper. Bake for 13 to 16 minutes or until cookies are crackled in appearance and edges are lightly browned. Cool on cookie sheet for 2 to 3 minutes, then transfer to a wire rack to cool completely. Store in an airtight container.



## black and white *pinwheels*

*Plan ahead for these attractive special-occasion cookies, as the dough needs to chill overnight.*

Makes about 96 cookies

- 6 cups unbleached, all-purpose flour
- 1 teaspoon baking powder
- 1 teaspoon salt
- 3 ounces unsweetened chocolate
- 2 cups unsalted butter, at room temperature
- 3 cups granulated sugar
- 4 large eggs
- 2 teaspoons pure vanilla extract

Place flour, baking powder, and salt in a mixing bowl. Reserve. Melt unsweetened chocolate in a double boiler over lightly simmering water.

Place butter in the Cuisinart™ mixing bowl. Insert the flat mixing paddle. Turn to speed 2 for 10 seconds and then increase to speed 4 for an additional 10 seconds to cream the butter. Scrape the paddle and bowl well. Turn to speed 2 and add the sugar. Once all the sugar is added, increase the speed to 4 and mix until fluffy, another 20 to 25 seconds. Scrape the paddle and bowl well. Turn speed to 2 and add the eggs, one at a time, increasing speed to 4 for about 10 seconds after each egg is added to fully incorporate (turn speed down to 2 before adding next egg). Add the vanilla. With the stand mixer running on speed 1, add dry ingredients in 2 to 3 additions. Once all the dry ingredients have been added, increase speed to 3 for about 10 seconds until the mixture is completely homogenous.

Remove dough and divide in half. Place one half back in the mixing bowl. Turn to speed 3 and pour in the melted chocolate. Mix until the chocolate is completely incorporated into the dough, about 45 seconds.

Divide both doughs in half again and press into flat squares approximately 5½" x 5½". Wrap in plastic and refrigerate to chill for about an hour.

When dough is adequately chilled, roll each out into a large rectangle about ⅛" thick onto sheets of lightly floured waxed paper (rectangle should be approximately 16" x 12"). Carefully turn out the chocolate dough rectangle directly on top of the white dough rectangle. Using the wax paper as a guide, roll the two doughs together tightly, jelly-roll style. Wrap the roll in plastic and refrigerate at least 2 hours, preferably overnight.

When ready to bake, preheat oven to 350°F and line baking sheets with parchment paper.

Place cookie log onto a cutting board. With a sharp knife, cut the log into ¼" slices. Arrange cookies on lined cookie sheets. Bake for about 13 to 15 minutes, turning baking sheet halfway, until cookies are lightly golden on the edges. Transfer cookies to a wire rack. Once cool store in an airtight container.



## citrus *sugar cookies*

The fresh flavors of lemon, lime and orange flavor these classic sugar cookies.

Makes about 60 cookies

- 6 cups unbleached, all-purpose flour
- 1 tablespoon baking soda
- $\frac{3}{4}$  teaspoon salt
- $\frac{3}{4}$  cup unsalted butter, at room temperature, cut into 12 pieces
- $\frac{3}{4}$  cup vegetable shortening (preferably non-hydrogenated)
- 3 cups granulated sugar plus  $\frac{3}{4}$  cup for rolling
- $\frac{3}{4}$  cup Lyle's Golden Syrup® (may use light corn syrup)
- 3 large eggs
- $1\frac{1}{2}$  teaspoons pure vanilla extract
- zest of 2 lemons (bitter white pith removed), finely chopped
- zest of 2 limes (bitter white pith removed), finely chopped
- zest of 2 oranges (bitter white pith removed), finely chopped

Preheat oven to 350°F. Line baking sheets with parchment. Place the flour, baking soda, and salt in a medium bowl. Reserve.

Place the butter and shortening in the Cuisinart™ mixing bowl. Insert the flat mixing paddle. Turn to speed 2 for about 10 seconds and then increase to speed 4 for an additional 10 seconds to cream the butter and shortening. Scrape bowl and paddle. Turn speed back to 2 and slowly add the 3 cups of sugar, increasing to speed 4 for about 30 seconds until the mixture is light and fluffy. Scrape the bowl and paddle. Turn to speed 2 and add the syrup. Add eggs one at a time with the stand mixer running on speed 2, increasing to speed 4 for 15 seconds to incorporate each egg. Scrape bowl and paddle. Add the vanilla. Add the dry ingredients in 3 additions, pushing the Fold button to incorporate. Finally, with the stand mixer running on speed 2, add the zests. Mix on speed 3 for an additional 15 to 20 seconds until smooth.

Using  $1\frac{1}{2}$  tablespoons of dough, shape into round balls and dip in remaining sugar to coat (you may use a #40 ice cream scoop). Arrange balls on parchment-lined baking sheet  $2\frac{1}{2}$  inches apart. Press each ball gently with the bottom of a flat glass. Bake in preheated 350°F oven for 10 to 12 minutes, until crackled and just beginning to turn golden. Remove from oven, let cool on baking sheet for 2 to 3 minutes, then transfer to a wire rack to cool completely. Store between sheets of waxed paper in an airtight container.



## pecan shortbread *linzer cookies*

*This shortbread is perfect for linzer cookies.*

Makes about 96 two-inch sandwich cookies

- $\frac{3}{4}$  cup toasted pecan halves
- $\frac{1}{3}$  cup plus 1 tablespoon granulated sugar
- $4\frac{1}{2}$  cups unbleached, all-purpose flour
- $\frac{3}{4}$  teaspoon salt
- 30 tablespoons ( $3\frac{3}{4}$  sticks) unsalted butter
- $1\frac{1}{2}$  cups confectioners' sugar, sifted, plus extra for dusting
- 2 teaspoons pure vanilla extract
- 1 cup raspberry jam

Pulse the pecans and granulated sugar together in a food processor until the mixture resembles a coarse meal. Reserve mixture. Combine flour and salt in a separate mixing bowl. Reserve.

Cut the butter into approximately tablespoon-size pieces and add to Cuisinart™ mixing bowl. Insert the flat mixing paddle. Turn to speed 2 and cream the butter for about 15 seconds. Increase to speed 4 for an additional 15 seconds. Scrape the bowl and paddle. Turn to speed 1 and add the confectioners' sugar. Increase to speed 4 to incorporate completely, about 20 seconds. Scrape bowl and paddle and then add the pecan/sugar mixture and vanilla and mix again on speed 2 to incorporate ingredients. Slowly add the dry ingredients while mixing on speed 1. Once all of the dry ingredients are added, turn to speed 2 until the mixture is a homogenous dough.

Cut the dough into two equal discs, wrap in plastic and place in refrigerator for at least 2 hours.

To Bake: Preheat oven to 350°F. Line two baking sheets with parchment paper.

Remove one dough disc from refrigerator. On a floured surface, roll the dough into an even  $\frac{1}{8}$ " thickness. Using a 2-inch round, fluted cookie cutter, cut rounds and place on parchment-lined baking sheet (an offset spatula works well to transfer cookies to baking sheets). Roll out and cut any remaining dough scraps in the same manner and place on lined baking sheets. Bake for 16 to 20 minutes, turning baking sheet midway through baking time. Cookies are done when they are lightly golden around the edges.

While the first batch of cookies is baking, roll out and cut the second dough and cut with the same 2-inch cookie cutters. Make a second cut with a  $\frac{3}{4}$ -inch round cookie cutter in the center of each cookie. Roll and cut remaining scraps. Transfer cookies to baking sheets and bake as directed.

Heat jam either in microwave or on stovetop until just liquid – jam will be too runny if it is too hot.

Once the cookies have cooled, spread about  $\frac{3}{4}$  teaspoon of jam on the center of the solid cookie. Then place the cut out cookie on top. Sprinkle with powdered sugar. Store in an airtight container with cookie layers separated by wax paper.



## peanut butter *surprise cookies*

Chocolate candy surprises in the center of these chewy peanut butter cookies.

Makes about 66 cookies

3¾ cups unbleached all-purpose flour  
2¼ teaspoons baking soda  
1½ teaspoons baking powder  
1½ teaspoons salt  
¾ cup unsalted butter, cut into 12 pieces, at room temperature  
¾ cup non-hydrogenated vegetable shortening  
1⅛ cups (1 cup + 2 tablespoons) packed brown sugar  
1⅛ cups (1 cup + 2 tablespoons) granulated sugar  
2¼ cups peanut butter (creamy or chunky)  
3 large eggs, at room temperature  
1½ teaspoons pure vanilla extract  
66 milk chocolate or caramel-filled chocolate candies, each about ¾-inch square\*  
granulated sugar for coating cookies

Place flour, baking soda, baking powder, and salt in a medium bowl. Stir with a whisk to blend. Reserve.

Place the butter and shortening in the Cuisinart™ mixing bowl. Insert the flat mixing paddle. Turn to speed 1 and blend for 1 minute, increase to speed 4 and cream for 2 minutes. Scrape the bowl and paddle. Cream for one minute longer on speed 4. Add both sugars, and cream for 2 minutes on speed 4. Scrape the bowl and paddle. Add peanut butter, creaming for 1 minute on speed 4. Scrape the bowl and paddle. Add the eggs, one at a time, mixing on speed 2 for 15 to 20 seconds after each egg is added. Add vanilla and mix for 15 seconds. Scrape the bowl and paddle.

Add half the dry ingredients; mix using speed 1 for 1 minute. Scrape the bowl and paddle. Add the remaining dry ingredients and mix using speed 1 until blended in, about 45 seconds. Scoop out the dough into walnut-sized balls (you may use a #40 ice cream scoop), shape each around a piece of chocolate and form into balls. Roll in granulated sugar. Refrigerate for 2 hours or longer before baking.

Fifteen minutes before baking, preheat oven to 375°F. Line baking sheets with parchment. Roll chilled cookie dough balls in granulated sugar again. Arrange evenly spaced, at least 2½ inches apart, on prepared baking sheets. Bake in preheated oven for 14 to 16 minutes. Let stand 3 minutes, then transfer to a wire rack to cool. Let cookies cool for 10 minutes or longer before eating so that the melted filling does not burn the tongue and has a chance to set.

\*Use candies such as Dove® Promises, Mini Rolo® Bites, squares of Cadbury® Caramello® or filled Perugina® chocolates.



## mini morsel *sugar cookies*

One of those “bet you can’t eat just one” cookies.

Makes about 72 cookies

- 4 cups unbleached, all-purpose flour
- 2 teaspoons baking powder
- 1 teaspoon salt
- 1 pound unsalted butter, at room temperature
- 1⅓ cups firmly packed brown sugar
- 1⅓ cups granulated sugar, divided
- 2 large eggs
- 2 teaspoons pure vanilla extract
- 1 teaspoon almond extract
- 2 cups mini chocolate morsels

Place flour, baking powder, and salt in a small bowl and stir to combine; reserve. Line baking sheets with parchment paper.

Place butter, brown sugar and ⅔ cup of the granulated sugar in the Cuisinart™ mixing bowl. Insert the flat mixing paddle. Turn to speed 1 to cream butter and sugars for 1 minute, scrape the paddle and bowl, then increase to speed 4 for 2 minutes until the mixture is light and fluffy. Scrape the paddle and bowl.

Add eggs and extracts; mix on speed 5 until combined and smooth, about 1 minute. Scrape the paddle and bottom and sides of mixing bowl. Beat for 15 seconds longer to blend. Add reserved dry ingredients and mini morsels to the bowl. Mix on speed 2 until just combined, 30 to 40 seconds. Place the remaining sugar in a shallow bowl.

Measure dough into walnut-size pieces, about 1½ tablespoons each (you may use a #50 ice cream scoop) – chill for 20 to 30 minutes. Roll in remaining granulated sugar. (If you have time, refrigerate cookie balls for 1 hour or overnight – may also be frozen. If frozen, re-dip in granulated sugar.) Arrange oven racks to upper and lower middle positions. Preheat oven to 375°F 15 to 20 minutes before baking. Arrange cookies on prepared baking sheets, evenly spaced, about 2 inches apart. Bake in preheated 375°F oven, about 10 to 13 minutes, reversing the baking sheets after 5 minutes, until edges of cookies are pale golden. Cool on baking sheets for 2 to 3 minutes. Transfer to a wire rack to cool completely. Store cookies in an airtight container in layers separated by waxed paper. Cookies may be frozen.



## delicious *brownies*

*Soft and fudgy, these brownies are a chocoholic's delight.*

Makes three 9-inch square pans of brownies

- cooking spray or melted butter*
- 2¼ cups (4½ sticks) *unsalted butter, cut into pieces*
- 18 ounces *semisweet chocolate, chopped*
- 3 ounces *unsweetened chocolate, chopped*
- 2 cups *unbleached, all-purpose flour*
- 2¼ teaspoons *baking powder*
- ¾ teaspoon *salt*
- 1⅞ cups (1 cup + 2 tablespoons) *granulated sugar*
- 1⅞ cups (1 cup + 2 tablespoons) *firmly packed brown sugar*
- 6 *large eggs*
- 3 teaspoons *pure vanilla extract*
- 1½ cup *semisweet chocolate morsels*
- 1½ cup *chopped walnuts or pecans, toasted*

Preheat oven to 350°F. Lightly coat three 9-inch square pans with cooking spray or melted butter. Place butter and both chocolates in a medium saucepan and melt over low heat. Remove from heat; cool to lukewarm – about 15 to 20 minutes. Place flour, baking powder and salt in a small bowl and stir; reserve.

Place the sugars and eggs in the Cuisinart™ mixing bowl. Insert the flat mixing paddle. Turn to speed 1 and mix for 30 seconds, then increase to speed 4 for 1½ to 2 minutes until very thick and pale caramel in color. Reduce to speed 1 and add the melted chocolate/butter mixture and vanilla while mixing. Mix until completely blended, about 1 minute; stop and scrape bowl. Sprinkle the flour mixture evenly over the chocolate mixture. Press Fold to blend in the flour, about 10 to 15 times. Add the chocolate morsels and nuts to the bowl and press Fold until just blended in. Pour into prepared pan and spread evenly. Bake in the preheated 350°F oven until a cake tester inserted into the center comes out with a few moist crumbs attached and top cracks in places, about 30 minutes – do not over-bake. Place the pan on a wire rack to cool. (May be made 1 day ahead. Cover with foil and let stand at room temperature.)

Cut brownies into squares to serve.

Note: You may change the brownies by omitting the chocolate morsels and nuts and substituting 3 to 4 cups of any of the following: chocolate covered raisins or cranberries, chocolate covered peanuts, mini candy “bites.”



## basic flaky *pastry dough*

*This recipe makes ample crust for a 9-to 11-inch regular or deep-dish pie or tart. Leftover pastry may be rolled out and cut into shapes to garnish the pie, or brushed with milk, sprinkled with sugar or cinnamon and sugar, and baked until lightly browned.*

Makes one or two crusts

*For a one-crust pie:*

- 1½ cups unbleached, all-purpose flour*
- ¼ teaspoon salt*
- ⅓ teaspoon baking powder*
- 8 tablespoons unsalted butter, cut into ¼-inch bits, well chilled*
- 1 tablespoon non-hydrogenated vegetable shortening, cut into ¼-inch bits, well chilled*
- 2 to 4 tablespoons ice water*

*For a two-crust pie:*

- 3 cups unbleached, all-purpose flour*
- ½ teaspoon salt*
- ¼ teaspoon baking powder*
- 16 tablespoons unsalted butter, cut into ½-inch pieces, well chilled*
- 2 tablespoons non-hydrogenated vegetable shortening, cut into ½-inch pieces, well chilled*
- 5 to 8 tablespoons ice water*

Place flour, salt, and baking powder in the Cuisinart™ mixing bowl. Insert the flat mixing paddle. Mix on speed 1 for 15 to 20 seconds. Sprinkle half the butter and all the shortening over the flour mixture. Mix on speed 1 for 45 seconds. With the mixer running, add the remaining bits of butter and mix until the mixture resembles crumbs but still with pea-sized bits of butter visible, about 45 to 60 seconds longer. With the stand mixer running, add the minimal amount of ice water, one tablespoon at a time. Stop mixing just when the mixture begins to form a ball. Turn off stand mixer. Using hands, gather up into a ball (2 balls for a two-crust recipe). Flatten into a disc about 6 inches in diameter and cover tightly with plastic wrap. Chill for at least 1 hour before using to allow the glutens in the flour to rest.

The dough will keep refrigerated for up to 3 days, or may be frozen (double-wrapped) for up to a month (thaw at room temperature for an hour before using).

To bake the pastry blind for a single-crust filled pie or tart, roll out pastry ⅛ inch thick to fit pan, crimp and seal edges. Prick bottom all over with a fork. Chill for 30 minutes. Preheat the oven to 400°F. Line crust with a sheet of aluminum foil or parchment paper and fill with pie weights, dry rice or beans. Bake for 15 minutes.

Note: For a sweeter piecrust add 1 or 2 tablespoons granulated sugar to the flour mixture in the beginning of the recipe.



## cookie *crumb crust*

You may make this basic cookie crumb crust with crushed cookies or graham crackers. It can be used for most pies that have a creamy or custard based filling.

Makes one 9-inch deep dish crust

- 8 ounces finely crushed cookie crumbs (gingersnaps, chocolate cookies, vanilla wafers or graham crackers)
- 2 to 3 tablespoons granulated sugar (to taste depending on cookies chosen)
- $\frac{1}{8}$  teaspoon salt
- 6 tablespoons unsalted butter, melted

Preheat oven to 350°F.

Place the crumbs, sugar and salt in the Cuisinart™ mixing bowl. Insert the flat mixing paddle. Turn to speed 1. While mixing, slowly add melted butter and mix until crumbs are totally coated. Transfer to a pie plate and press evenly into bottom and up the sides of the plate. Use the bottom of a glass or custard cup to firmly tamp down the bottom of the crust.

Place in preheated 350°F oven and bake for 8 to 10 minutes. Cool on a wire rack before using.



## chocolate almond *cream pie*

You may vary this pie by using finely chopped toasted hazelnuts.  
The creamy filling is reminiscent of cannoli.

Makes one 9-inch deep dish pie, 8 to 12 servings

- 1¼ cups chocolate cookie crumbs
- 3 tablespoons unsalted butter, melted
- 1½ cups whole-milk ricotta cheese
- 1 cup mascarpone cheese
- ¾ cup granulated sugar
- 1 teaspoon pure vanilla extract
- 1 teaspoon pure almond extract
- 1 cup finely ground toasted almonds
- ¾ cup finely ground semisweet chocolate\*
- 1½ cups heavy cream

Preheat oven to 350°F. Combine cookie crumbs and melted butter until well blended. Press firmly into bottom and sides of 9-inch deep dish pie plate. Place in oven and bake for 10 minutes – until crust is set. Cool completely before filling.

Place ricotta and mascarpone cheeses in Cuisinart™ mixing bowl. Insert the chef's whisk. Turn to speed 6 and whip for 30 to 40 seconds. With the stand mixer running, add granulated sugar and both extracts. Continue to whip for 1 minute. Scrape bottom and sides of mixing bowl. Turn back to speed 6 and whip for 1 minute. With the stand mixer running, add ground almonds and ground chocolate, ¼ cup at a time, mixing for 20 seconds after each addition. Scrape bottom and sides of mixing bowl. Turn to speed 8 and gradually add heavy cream; whip for 1 minute. Scrape bottom and sides of bowl. Increase to speed 12 and whip for 2 minutes, until evenly thickened and increased in volume. Gently transfer whipped mixture to cooled crust. Cover and refrigerate for 8 hours or longer before serving. Serve chilled. If desired, garnish with toasted sliced almonds, shaved chocolate and a fresh strawberry.

\*To grind chocolate, freeze chocolate chips or ¼-inch pieces of chocolate. Place in food processor fitted with the metal blade and pulse to chop finely.



## mile high *lemon meringue pie*

*Mile high to rival the pie in any great American diner. Our meringue is cooked and totally safe. This is somewhat like a toasted marshmallow on top of lemon pudding.*

Makes 8 servings

*One Flaky Pastry Crust, baked blind – page 44*

### *Lemon Filling:*

- 1 cup granulated sugar
- 3 tablespoons cornstarch
- 2 tablespoons unbleached, all-purpose flour
- $\frac{3}{4}$  cup water
- 5 large egg yolks, lightly beaten
- 3 tablespoons unsalted butter, cut into  $\frac{1}{2}$ -inch pieces
- $\frac{1}{2}$  cup fresh lemon juice  
finely chopped zest of 2 lemons

### *Meringue Topping:*

- 1 tablespoon cornstarch dissolved in  $\frac{1}{4}$  cup boiling water
- 6 large egg whites
- $\frac{3}{4}$  cup + 2 tablespoons granulated sugar
- 2 tablespoons water
- 1 teaspoon cream of tartar
- $\frac{1}{8}$  teaspoon salt
- 1 teaspoon pure vanilla extract



Preheat oven to 325°F. Have the prebaked flaky pastry crust ready to fill. When making Lemon Meringue Pie, it is important that the filling be hot when topped with the meringue before baking to prevent the meringue from shrinking. Have a saucepan ready with 1 inch of simmering water. The pan should be able to accommodate the Cuisinart™ mixing bowl without allowing the bottom of the bowl to touch the water.

To make the lemon filling, place the granulated sugar, cornstarch and flour in a 2½-quart saucepan and stir. While stirring, add the water and stir until smooth. Place over medium heat and cook until slightly thickened, about 2 minutes. Whisking constantly, add about one half of the hot mixture to the egg yolks. Stir the tempered egg yolks into the rest of the liquid and place over medium heat, cooking until thickened and just beginning to bubble, about 3 to 4 minutes. Add the butter and stir until blended. Stir in the lemon juice and zest. Stir until completely blended. Cover until ready to fill pie.

To make the meringue, stir the cornstarch into the boiling water and reserve. Place the egg whites, 2 tablespoons of the granulated sugar, the 2 tablespoons water, and the cream of tartar in the Cuisinart™ mixing bowl and stir until smooth. Place over the pan of simmering water and stir constantly with a spotlessly clean rubber spatula until the mixture registers 160°F on an instant-read thermometer – start checking the temperature after about a minute of stirring. When the egg white mixture registers 160°F, dry off the bottom of the bowl and place on the stand mixer. Insert the chef's whisk. Stir the cornstarch mixture. Whisk the egg white mixture on speed 3 for 1 minute while slowly adding the cornstarch mixture. Increase to speed 10 and slowly add the remaining  $\frac{3}{4}$  cup of granulated sugar. Add the salt and vanilla and whip until the egg whites form stiff peaks, about 4 minutes.

Spread the hot lemon filling in the prepared pie shell. Top the filling with the meringue, taking care to spread the meringue to touch the crust all the way around. Make decorative swirls and peaks on the meringue as desired. This makes a generous, high meringue topping – if you prefer, use less.

Bake in the preheated 325°F oven for about 30 minutes until lightly browned. Cool at room temperature for about an hour, then refrigerate, uncovered, until chilled for several hours. Mile High Lemon Meringue Pie is best served the day it is made.

## pumpkin *mousse pie*

*Drambuie® makes this pumpkin mousse pie a special treat.*

Makes 8 to 12 servings

- 1 9-inch baked pie crust (see page 44) or cookie crumb crust (see page 45)
- 1 tablespoon gelatin powder
- ¼ cup Drambuie® or Grand Marnier®
- 1½ cups canned or cooked pumpkin purée (solid pack pumpkin, not pumpkin pie filling)
- 3 large egg yolks, lightly beaten
- ½ cup packed brown sugar
- ½ cup heavy cream
- ½ teaspoon salt
- ¾ teaspoon cinnamon
- ½ teaspoon ginger
- ¼ teaspoon allspice
- ⅛ teaspoon freshly ground nutmeg
- 3 large egg whites
- ½ cup granulated sugar, divided

Sprinkle gelatin over liqueur in a small bowl, and let stand to soften, about 5 minutes.

Place pumpkin, egg yolks, brown sugar, heavy cream, salt, cinnamon, ginger, allspice, and nutmeg in a 2½ quart saucepan. Cook, stirring frequently with a wooden spoon over medium high heat until it maintains a gentle, even slow boil for 5 minutes, the sugar is melted and the mixture thickens slightly. Add the liqueur/gelatin mixture and stir until completely dissolved. Transfer to a large bowl and let cool to room temperature (this may be hastened by placing the bowl in a larger bowl of ice and water – stir pumpkin mixture to lower temperature).

Place the egg whites and half the granulated sugar in the Cuisinart™ mixing bowl. Place bowl over a pan of simmering water and whisk the whites until warm and sugar is dissolved – the liquid egg white/sugar temperature should reach 160°F to make certain they are sanitized and safe. Do not whisk as that will create a foam which is harder to bring to temperature. After the temperature has reached 160°F, place in the mixing bowl. Insert the chef's whisk. Turn to speed 1 and increase slowly to speed 5; whip until foamy. After the egg whites are foamy, increase the speed to 8 and while gradually adding the remaining sugar (about 1 tablespoon at a time), whip until no longer warm to the touch, about 5 to 8 minutes.

Stir about ¼ of the whipped egg whites into the cooled pumpkin mixture to lighten the mixture, then gently and carefully fold the remaining egg whites in, about ⅓ at a time.

Gently spoon into the prepared crust. Chill for several hours to set before serving. If desired, top with freshly whipped cream to serve.



## raspberry mascarpone mousse

Serve this mousse in martini glasses garnished with fresh raspberries for a dramatic presentation.

Makes 8 cups mousse, about 12 to 16 servings

1½ tablespoons gelatin powder  
3 tablespoons cold water  
18 ounces fresh or frozen (not in juice) raspberries  
1 cup granulated sugar  
3 tablespoons crème de cassis or Kirschwasser  
12 ounces mascarpone cheese  
⅓ cup confectioners' sugar  
1½ cups heavy cream, well chilled  
fresh raspberries and mint leaves for garnish  
shaved chocolate curls for garnish

Sprinkle the gelatin over the cold water. Let stand 5 minutes or longer to soften.

Combine the raspberries and granulated sugar in a 2-quart saucepan. Bring to a boil over medium-high heat, about 6 minutes. Stir to dissolve sugar. Using a fine mesh strainer (chinois) set over medium bowl, strain, pressing out as much of the liquid as possible, until just the seeds remain. Discard the seeds. Stir the softened gelatin into the raspberry sauce. Add crème de cassis. Cool until slightly thickened, about 30 minutes.

Place the mascarpone and confectioners' sugar in Cuisinart™ mixing bowl. Insert the chef's whisk. Mix on speed 4 for 2 minutes, until smooth and creamy. Scrape the sides and bottom of mixing bowl and the whisk. Mixture should be thick and increased in volume. Add the cooled raspberry mixture using speed 1 until thoroughly combined, about 1 minute. Scrape the mixing bowl and whisk. While mixing on speed 4, add the chilled heavy cream in a steady stream. Whip for 1 minute. Scrape the bottom and sides of the mixing bowl. Whip on speed 10 for 2½ to 3 minutes.

Spoon or pipe into stemmed glasses. Refrigerate for 6 hours or longer before serving. Garnish with fresh raspberries and a mint leaf, or curls of shaved dark or white chocolate.



## sinfully rich *chocolate mousse*

*This rich mousse doubles as a dessert all on its own or as a filling for your favorite cake.*

- 3 egg yolks
- 1 tablespoon water
- 1 tablespoon Kahlúa®
- 12 ounces bittersweet chocolate, finely chopped
- 1½ cups heavy cream
- 1 teaspoon pure vanilla extract

Makes 4 cups

Place egg yolks, water, and Kahlúa® in the Cuisinart™ mixing bowl. Insert the chef's whisk. Mix on speed 4 for about 30 seconds just to break up the yolks and to mix the ingredients together.

Place the chopped chocolate in a stainless steel mixing bowl. Reserve.

Bring a medium saucepan filled ⅓ of the way with water to a simmer. The pan should be able to accommodate the Cuisinart™ mixing bowl, without allowing the bottom of the bowl to touch the water. Once the water is simmering, place the mixing bowl in the saucepan over the simmering water. Whisk continuously by hand until mixture thickens and reaches 165°F.

At the same time place ½ cup of the heavy cream in a small saucepan and bring to a slight simmer. Pour it over the chopped chocolate and stir to melt. If the chocolate does not entirely melt, place bowl over the simmering water and stir until it does.

When the egg mixture is ready, return it to the stand mixer still fitted with the chef's whisk. Turn to speed 4. While the stand mixer is running, slowly pour in the melted chocolate. Mix until completely combined. Stir in vanilla. Transfer mixture to a clean mixing bowl and cool slightly in the refrigerator.

While chocolate mixture is cooling, wash the Cuisinart™ mixing bowl and chef's whisk. Rinse with cold water and dry well. Place the remaining cup of cream in the mixing bowl and insert the chef's whisk. Whisk the cream starting on speed 4 and gradually reaching speed 12 for about 1 minute and 20 seconds, until the cream holds soft peaks.

Using a large rubber spatula, fold the cream into the chocolate mixture in 3 additions. Make sure the ingredients are well incorporated after each addition. Transfer mousse either to individual soufflé cups or a glass container. Cover with plastic and refrigerate for at least 12 hours.



## classic *tiramisù*

*This classic dessert never goes out of style.*

Makes one 9x9 inch pan of tiramisù

- 3 large egg yolks
- ½ cup granulated sugar
- 3 tablespoons Marsala wine, champagne, or dry white wine
- 8 ounces mascarpone
- 1 cup heavy cream
- ¼ cup Kahlúa®
- 2 cups espresso or strongly brewed coffee
- 28 savoiardi or ladyfingers

Place egg yolks in Cuisinart™ mixing bowl. Insert the chef's whisk. Turn to speed 3 and mix to break up yolks. Add sugar and wine and continue to mix for another 30 seconds. Place mixing bowl over a saucepan of simmering water, being careful not to let the bottom of the bowl touch the water. Whisk continuously by hand for about 5 minutes, until mixture becomes very thick and reaches 165°F. Once mixture comes to temperature, return to the stand mixer. Mix on speed 8 until mixture is cool. This egg mixture is called a sabayon.

While the sabayon is cooling, place mascarpone in a separate mixing bowl. With a rubber spatula, mix up mascarpone until smooth. Once sabayon is cool, fold it into the mascarpone in 3 additions with a large rubber spatula. Be sure to incorporate the 2 mixtures fully and evenly.

Transfer mixture to a separate mixing bowl. Wash the Cuisinart™ mixing bowl and whisk and rinse with cold water, then dry. Insert the chef's whisk. Place heavy cream and two tablespoons Kahlúa® in the Cuisinart™ mixing bowl. Turn to speed 4 and then increase to speed 7 for about 1½ minutes to whip until soft peaks form. Fold the cream into the mascarpone mixture in 3 additions, using a large rubber spatula.

Mix the espresso and remaining 2 tablespoons of Kahlúa® in a shallow pan. Dip the ladyfingers in the espresso mixture, 4 seconds on each side. Line the dipped ladyfingers on the bottom of a 9-inch square pan, cutting them to fit the pan as you need them. Pour half the mascarpone/cream mixture on top of the ladyfingers. Repeat with a second layer of soaked ladyfingers. Finish by pouring the remaining cream on top. Cover with plastic and chill for at least 6 hours.

When ready to serve, dust the top with cocoa powder and/or chocolate curls.



## chocolate frosting

Perfect topping for a yellow cupcake!

Makes about 2 cups

- 10 ounces semisweet chocolate, chopped or chips
- 2 tablespoons unsalted butter, at room temperature
- 1 cup heavy cream

Place chocolate and butter in the Cuisinart™ mixing bowl. Reserve.

Scald heavy cream in a small saucepan (heat until just bubbling around edges – may be done in microwave). Once cream starts to scald, pour it over the chocolate and butter. Stir with a wooden spoon to cool mixture slightly. Allow to rest for about 5 minutes.

Insert the chef's whisk. Turn to speed 1 and gradually increase to speed 12. Whip for about 2 minutes until the frosting thickens and increases slightly in volume.

Note: If doubling recipe, bring the speed up only to 7 or 8, as the chocolate will spatter on the maximum setting.

## swiss buttercream

On its own or flavored, this buttercream makes the perfect frosting.

Makes about 6 cups, enough to frost a 9-inch double layer cake

- 8 large egg whites
- 1¾ cups granulated sugar
- 4½ cups unsalted butter
- 1 teaspoon pure vanilla extract
- 1 tablespoon fresh lemon juice

Place egg whites and sugar in the Cuisinart™ mixing bowl. Place bowl over a pan of simmering water and whisk the whites until warm and sugar is dissolved (the liquid temperature should reach 140°F). Place bowl on the stand mixer. Insert the chef's whisk.

Turn to speed 10. Set timer for 15 minutes. The object is for the whites to whisk until cool, approximately 15 minutes. Once cool, turn stand mixer to speed 3 and add the butter slowly, in pieces, incorporating each piece before adding the next. Once all the butter is added, add the vanilla and lemon juice. Turn back up to speed 8 until the buttercream is smooth and silky.

Buttercream will keep in the refrigerator for up to 10 days.

Buttercream is very versatile – any flavoring can be added once all the butter is incorporated.



## cream cheese frosting

A classic cream cheese frosting, perfect for a variety of cakes, especially carrot and chocolate.

Makes 2 cups

- 2¾ cups confectioners' sugar
- 1 8-ounce package cream cheese, at room temperature
- 4 tablespoons unsalted butter, at room temperature
- 1 teaspoon pure vanilla extract

Sift the sugar into a small bowl and reserve.

Place cream cheese in the Cuisinart™ mixing bowl. Insert the flat mixing paddle. Turn to speed 3 and beat cheese until smooth in consistency. Add butter and beat until it is smooth and incorporated with the cheese.

With the stand mixer running on speed 2 slowly pour the sugar into the mixing bowl until all is incorporated. Mix in vanilla. Refrigerate for at least 30 minutes to set.

## chocolate glaze/ganache

A deep chocolate way to frost or fill your favorite cakes.

Makes about 1¼ cups

- 6 ounces bittersweet chocolate, chopped
- ¾ cup heavy cream
- 3 tablespoons unsalted butter

Place chopped chocolate in the Cuisinart™ mixing bowl. Place heavy cream in a small saucepan and bring to just a simmer. Pour hot cream over chocolate. Insert the chef's whisk. Turn to speed 4. Mix until chocolate is melted and the mixture comes together. Add butter and whisk until shiny.



## golden layer cake

Very versatile, all-occasion cake.

Makes two short 9-inch layers

- 2 cups cake flour
- 2 teaspoons baking powder
- ½ teaspoon salt
- ½ pound unsalted butter,  
at room temperature
- 1¼ cups granulated sugar
- 3 large eggs
- 2 large egg yolks
- 2 teaspoons pure vanilla extract
- ¾ cup buttermilk

Preheat oven to 350°F. Butter and flour two 9-inch pans. Cut a circle of wax paper or parchment paper to fit the bottom inside of the pan. Place the circle inside the pan and butter and flour it as well.

Sift the flour, baking powder, and salt together in a mixing bowl and reserve.

Place the butter in the Cuisinart™ mixing bowl. Insert the flat mixing paddle. Turn to speed 2 to cream the butter, about 30 seconds. Add the sugar with the stand mixer running on speed 2. Mix until the sugar and butter are well creamed and light, about 2 minutes. Scrape the bowl and paddle and mix again for another 30 seconds. With the stand mixer running on speed 1, add the eggs and yolks, one at a time, making sure each is incorporated before adding the next. Mix in the vanilla. Scrape the bowl and paddle. With the stand mixer running on speed 1, add the dry ingredients and buttermilk alternately, beginning and ending with the dry ingredients. Increase to speed 2 and run for about 20 seconds. Scrape the bowl completely to make sure all ingredients are evenly incorporated.

Pour batter evenly into prepared pans.

Bake in preheated 350°F oven for 30 to 35 minutes. The cakes should be slightly puffed and golden and a cake tester should come out clean.

Allow to cool on a wire rack. Once cool to the touch, release cakes from pan and continue to cool completely on the wire rack before frosting.



## rich chocolate cake

A delicious and rich chocolate cake for any special occasion.

Makes one Bundt® cake

- cooking spray
- 2 cups unbleached, all-purpose flour
- 1 teaspoon baking powder
- ¼ teaspoon baking soda
- ½ teaspoon salt
- 3 ounces unsweetened chocolate, chopped
- ¾ cup unsweetened cocoa powder
- 1 teaspoon espresso powder
- 1 cup boiling water
- 1 cup unsalted butter, at room temperature
- 1 cup granulated sugar
- 1 cup light brown sugar
- 3 large eggs
- 2 teaspoons pure vanilla extract
- ¾ cup sour cream
- 1 cup semisweet chocolate chips

Preheat oven to 350°F. Coat a 12-cup Bundt® pan with cooking spray.

Sift the flour, baking powder, baking soda, and salt into a mixing bowl three times. Reserve.

Place the chocolate, cocoa powder, and espresso powder in a small mixing bowl. Pour the boiling water over the mixture and stir so that the chocolate melts. This mixture will be very thick.

Place butter in the Cuisinart™ mixing bowl. Insert the flat mixing paddle. Turn to speed 2. Beat the butter for about 15 to 20 seconds. Add the sugars and continue to mix until the butter and sugars are light and fluffy, about 45 seconds. Add the eggs one at a time, mixing well between each addition. Add the vanilla. Spoon the chocolate mixture into the mixing bowl and mix well until ingredients are incorporated. Add ⅓ of the dry ingredients and press Fold until just incorporated. Add ½ of the sour cream and press Fold until just incorporated. Continue folding in the ingredients alternately, ending with the dry ingredients. Fold in chocolate chips.

Pour batter into prepared pan. Bake 50 to 55 minutes in preheated 350°F oven until a cake tester comes out clean. Place on a wire rack to cool. Cool completely before cutting.



## old-fashioned *pound cake*

*A traditional, moist pound cake with a lemon twist.*

Makes two loaves, each yielding sixteen ½-inch slices

- cooking spray*
- 3½ *cups cake flour*
- 1 *teaspoon salt*
- 2 *cups unsalted butter, at room temperature*
- 2½ *cups granulated sugar*
- 8 *large eggs, at room temperature*
- 2 *teaspoons pure vanilla extract*
- 1 *tablespoon plus 1 teaspoon lemon zest (approximately 2 lemons)*

Preheat oven to 325°F. Spray two 9x5x3-inch loaf pans with cooking spray.

Sift the flour and salt together in a small mixing bowl. Reserve.

Place the butter in the Cuisinart™ mixing bowl. Insert the flat mixing paddle. Turn to speed 1. Cream butter for 30 seconds, then turn to speed 3 for 30 seconds. Scrape both the paddle and mixing bowl well. Reduce to speed 2 and add the sugar. Increase to speed 4 until light and fluffy, about 1 minute. Scrape both the paddle and bowl well. Add the eggs one at a time on speed 2, beating after each egg is added until mixture is smooth, before adding the next. Mix in the vanilla and the lemon zest. Add the dry ingredients, slowly in 3 additions, with the stand mixer running on speed 1. Be sure to fully incorporate ingredients and be careful not to overwork the batter.

Pour batter into prepared loaf pans. Bake in preheated 325°F oven for about 60 to 70 minutes, until a cake tester comes out clean. Place on a wire rack to cool. Cool completely before cutting.



## kahúla® angel *food cake*

*Light and airy, angel food cakes have no fat!*

Makes 12 servings

- 1½ cups granulated sugar, sifted
- 1¼ cups cake flour, sifted
- 1 teaspoon pure vanilla extract
- 1 tablespoon espresso powder
- 2 tablespoons Kahlúa®, or any coffee-flavored liqueur
- 12 large egg whites
- 1¼ teaspoons cream of tartar
- ¼ teaspoon salt

Preheat oven to 325°F.

Sift ¾ cup of the sugar together with the cake flour in a mixing bowl and reserve.

Stir together vanilla, espresso powder, and Kahlúa® in a small bowl and reserve.

Place egg whites in Cuisinart™ mixing bowl. Insert the chef's whisk. Turn to speed 9. After 30 seconds add cream of tartar and salt and increase to speed 12 until soft peaks form, about 1 minute 15 seconds. Slowly add remaining ¾ cup of granulated sugar and continue to mix on speed 12 until the peaks are firm and glossy, about another 30 seconds. Remove bowl from stand mixer.

Gradually sift the reserved flour/sugar mixture into the whites and carefully fold in with a large rubber spatula. Fold in the espresso mixture. Be gentle when folding but at the same time make sure all ingredients are evenly incorporated.

Spoon batter into an ungreased 9-inch tube pan. Smooth and even the top by spreading with a rubber spatula.

Bake in preheated 325°F oven for 40 to 45 minutes, until a cake tester comes out clean. Invert pan onto the neck of an empty long-necked bottle (such as a wine bottle) and allow to cool completely.

To remove cake from pan, slide the tip of a long, narrow knife between the cake and the pan. Cover the pan with a plate and invert it. Slide the knife along the bottom of the pan until it is free.



## coconut *cake*

*This moist, delicious cake is perfect for any special occasion.*

Makes two 9-inch round cakes

- cooking spray*
- 3 *cups unbleached, all-purpose flour*
- 1 *teaspoon baking powder*
- ½ *teaspoon baking soda*
- ½ *teaspoon salt*
- 1 *cup unsalted butter, at room temperature*
- 2 *cups granulated sugar*
- 3 *large eggs*
- 2 *large yolks*
- ½ *cup crème fraîche or sour cream*
- ½ *cup cream of coconut*
- ½ *teaspoon pure vanilla extract*
- ½ *teaspoon coconut extract*
- 1½ *cups dried coconut*

Preheat oven to 325°F. Spray two 9-inch round pans with cooking spray.

In a bowl stir together the flour, baking powder, baking soda, and salt. Reserve.

Place butter in the Cuisinart™ mixing bowl. Insert the flat mixing paddle. Turn to speed 1. Cream butter for 30 seconds, then turn to speed 3 for 30 seconds.

Reduce to speed 2 and add the sugar, then increase to speed 4 until light and fluffy, about 1 minute. Reduce to speed 2 and add the eggs and yolks one at a time, beating until batter is smooth before adding the next.

In a separate bowl, mix the crème fraîche and cream of coconut together with both extracts. With stand mixer running on speed 2 slowly add the dry ingredients and crème fraîche mixture alternately, ending with the dry ingredients. Finally, mix in the dried coconut quickly but thoroughly.

The batter will be extremely thick. Spoon the batter evenly between the two pans and bake in the preheated 325°F oven for 45 to 50 minutes, until a cake tester comes out clean.

Cool pans on a wire rack. When the pans are cool enough to touch, invert the pans on the rack and remove the cakes. Leave cakes on wire rack until completely cooled.

This is a very versatile cake. To make a layer cake, cut each cake in half horizontally and frost using your favorite frosting. One frosting that works extremely well is the Swiss Buttercream (page 52) for both between layers and the outside of the cake. To be even more extravagant, frost with the buttercream but fill two of the layers with Chocolate Glaze (page 53). To finish, sprinkle the top of the cake with dried coconut.



## fresh ginger cake

*A rich, moist cake made with fresh and powdered ginger. Topped with cream cheese frosting and fresh fruit, this makes a very special dessert.*

Makes one 9-inch two-layer cake, 8 to 12 servings

- cooking spray
- 2½ cups unbleached, all-purpose flour
- 1 teaspoon powdered ginger
- ½ teaspoon ground cinnamon
- ½ teaspoon ground allspice
- ¼ teaspoon freshly ground black pepper
- 1 cup Lyle's Golden Syrup® (may use light corn syrup)
- 1 cup packed light brown sugar
- 1 cup melted unsalted butter
- 2 teaspoons baking soda
- 1 cup boiling water
- ½ cup peeled and finely grated/chopped fresh gingerroot (about 3 ounces)
- 2 large eggs, at room temperature

Preheat oven to 325°F. Lightly coat two 9x2-inch round cake pans with cooking spray. Line the bottom of each with a 9-inch round of parchment and coat with cooking spray.

Place flour, ginger, cinnamon, allspice, and pepper in a medium bowl and stir to blend; reserve.

Place Lyle's Golden Syrup®, brown sugar, and melted butter in the Cuisinart™ mixing bowl. Insert the flat mixing paddle. Mix for 30 seconds on speed 1, increase to speed 3 and mix for 3 minutes until completely homogenous. Stir the baking soda into the boiling water (it will foam – use a two-cup measure). Add water and fresh ginger to syrup mixture in bowl. Set timer for 10 minutes and mix on speed 1 until bowl is lukewarm to touch, about 10 minutes (add more mixing time if not lukewarm after 10 minutes). Using speed 2, add eggs, one at a time, mixing for 30 seconds after each addition. Scrape the bottom and sides of the bowl.

Sprinkle half the flour mixture evenly over the top of the liquid mixture. Mix on speed 1 for 30 seconds. Add remaining dry ingredients, mixing on speed 2 for 20 seconds. Scrape the bottom and sides of the mixing bowl and repeat. Evenly divide the batter between the 2 prepared pans. Bake in preheated 325°F oven for 55 to 65 minutes, until cake tester is clean when inserted into the center. The top of the cake will still appear moist. Cool in pans on a wire rack for 10 minutes, then turn out, remove parchment and cool on a wire rack completely.

To assemble cake:

Prepare Cream Cheese Frosting (page 53). Place one layer of the cooled Fresh Ginger Cake on a serving platter or cake round. Top with an even layer of Cream Cheese Frosting, about ¼ to ½-inch thick. Place the second layer on top. Frost top only or top and sides with remaining frosting. Garnish with sliced fresh stone fruit such as apricots, peaches, or plums, or with blueberries and/or raspberries, or sliced, peeled kiwi. Keep refrigerated until ready to serve.



## the ultimate *flourless chocolate cake*

*Rich, creamy, chocolaty – absolutely deliciously decadent – need we say more?*

Makes one 9-inch cake, 12 to 16 servings

- melted, unsalted butter*
- ½ *cup water*
- 1 *cup granulated sugar*
- ½ *cup brown sugar, divided*
- 1 *tablespoon instant espresso powder*
- 12 *ounces semisweet chocolate, chopped into ¼-inch pieces*
- 6 *ounces bittersweet chocolate, chopped into ¼-inch pieces*
- 1 *cup unsalted butter, cut into ½-inch pieces*
- 1 *tablespoon pure vanilla extract*
- 1 *tablespoon crème de cacao, brandy or coffee liqueur*
- 6 *large eggs*
- powdered sugar for dusting cake or Chocolate Glaze (page 53)*



Preheat oven to 300°F. Brush a 9x3-inch round cake pan with melted unsalted butter. Line bottom with a 9-inch round of parchment paper and brush parchment with melted butter.

Place water, granulated sugar, ¼ cup of the brown sugar, and espresso powder in a 2½-quart saucepan. Bring to a simmer over medium heat and cook until sugars are dissolved. Reduce heat to low. Add all chopped chocolate and stir with a wooden spoon until smooth. Remove from heat and add half the butter; stir until smooth. Add remaining butter, vanilla, and liqueur or brandy; stir until smooth. Let cool while continuing.

Place eggs and remaining ¼ cup brown sugar in the Cuisinart™ mixing bowl. Insert flat mixing paddle. Set timer for 12 minutes and mix on speed 10 until thickened and light, similar to mayonnaise in texture. With the stand mixer set on speed 2, add the slightly cooled chocolate mixture in a steady stream, and mix for 1 minute. Scrape the bowl and paddle. Remove the bowl from the stand mixer. Using a large rubber spatula, gently fold until the mixture is completely homogenous in color, with no streaks of chocolate or egg – be gentle, taking care not to deflate the egg mixture too much. Transfer to prepared pan. Place filled cake pan in a larger pan and add hot water so that it is halfway up the sides of the cake pan. Place in preheated 300°F oven and bake for 1 hour 20 minutes. Cake should rise evenly, and when done, the top will have the appearance of brownies, but the cake will still seem a little jiggly. Let cool at room temperature, then cover and refrigerate for 8 hours or overnight.

To unmold, dip the bottom of the cake pan in hot water for 10 to 15 seconds. Dry pan and invert cake onto a serving platter. Remove parchment. Dust with powdered sugar before serving, or top with Chocolate Glaze (page 53). Smooth chocolate glaze over top with a minimum of strokes to keep its shine and allow to drip down the sides of the cake.

## sour cream *cheesecake*

A classic, creamy cheesecake.

Makes one 10-inch cheesecake, 12 to 16 servings

cooking spray

*Crust:*

- 1¼ cups graham cracker, vanilla wafer or gingersnap crumbs
- 2½ tablespoons granulated sugar
- ½ teaspoon ground cinnamon
- ⅓ cup melted unsalted butter

*Topping:*

- 1½ cups sour cream
- 3 tablespoons granulated sugar
- ¾ teaspoon pure vanilla extract

*Filling:*

- 1½ pounds lowfat cream cheese, at room temperature
- 1 pound regular cream cheese, at room temperature
- 1¼ cups granulated sugar
- 1½ tablespoons cornstarch
- 6 large eggs, at room temperature
- 1¼ cups sour cream
- 2¼ teaspoons pure vanilla extract
- ¾ teaspoon almond extract

---

Note: Sour Cream Cheesecake is best when made a day ahead. This cheesecake does not freeze well and freezing is not recommended. The Sour Cream Cheesecake can be served plain, topped with fresh fruit of your choice, or served with a fruit sauce.

Arrange the rack in the center of the oven. Preheat oven to 350°F. Lightly coat a 10x3-inch springform or removable bottom cheesecake pan with cooking spray. Line the outside of the pan with heavy duty foil.

Insert the flat mixing paddle. Place the cracker or cookie crumbs, sugar, cinnamon, and melted butter in the Cuisinart™ mixing bowl. Turn to speed 2 and blend, about 30 seconds. Pour into prepared pan and flatten to cover the bottom evenly. Use the bottom of a drinking glass or measuring cup to tamp down firmly. Bake in preheated 350°F oven for 8 to 10 minutes. Let cool while preparing filling. Wipe mixing bowl and paddle clean of all crumbs.

Place the sour cream in the Cuisinart™ mixing bowl with sugar and vanilla to make the topping. Turn to speed 2 and mix for 45 seconds to blend and dissolve sugar. Transfer to a bowl, cover and refrigerate until ready to use to top cheesecake.

Place all the cream cheese in the Cuisinart™ mixing bowl. Turn to speed 1 and stir until just smooth, about 30 seconds. Scrape the mixing bowl and paddle. Add sugar, ¼ cup at a time, and then cornstarch. Stir on speed 2 until smooth, about 30 seconds after each addition. Scrape the bottom and sides of the bowl and the paddle after adding half the sugar. Mixing on speed 2, add the eggs, one at a time, mixing about 30 seconds after each addition. Scrape the bottom and sides of the bowl and paddle after adding 3 eggs, then after all 6 eggs have been added. Add the sour cream, vanilla and almond extracts, and mix on speed 1 until creamy and homogeneous, about 1 minute. Pour into cooled prepared crust – do not scrape any thick bits from the sides of the bowl as they are not thoroughly mixed in and will change the texture of your finished cheesecake.

Place the pan in a jelly-roll pan or roasting pan. Place on oven rack and pour hot water into the bottom pan to a depth of at least ½ inch to create a water bath. Bake the cheesecake in preheated 350°F oven for 45 minutes, then lower oven temperature to 325°F and bake for 40 minutes. Increase temperature to 350°F and bake for an additional 5 minutes. Spread reserved sour cream topping evenly over cheesecake and bake for 15 minutes longer. Remove from oven, remove foil and cool on a wire rack for 1 hour. Refrigerate uncovered until cold, then cover.

## chocolate *marble cheesecake*

*Ribbons of semisweet chocolate cheesecake are swirled throughout a classic cheesecake on top of a chocolate brownie cookie crust.*

Makes one 10-inch cheesecake, 12 to 16 servings

cooking spray

For the crust:

- 8 tablespoons unsalted butter, at room temperature
- 1¼ cups unbleached, all-purpose flour
- 5 tablespoons packed brown sugar
- 5 tablespoons unsweetened cocoa
- 1 large egg yolk
- 1 teaspoon pure vanilla extract

For the filling:

- 3½ pounds lowfat cream cheese, at room temperature
- 1¾ cups granulated sugar
- 7 large eggs, at room temperature
- 1½ tablespoons pure vanilla extract
- 12 ounces semisweet chocolate, melted and cooled

Lightly coat a 10x3-inch springform pan with cooking spray. Line the outside of the pan with heavy-duty aluminum foil. Preheat oven to 350°F.

Insert the flat mixing paddle. Place the crust ingredients in the Cuisinart™ mixing bowl. Stir until completely blended on speed 2, about 1 to 1½ minutes. Pour into prepared pan and flatten to cover the bottom and about ½ inch up the sides evenly. Use the bottom of a drinking glass or measuring cup to tamp down firmly. Bake in preheated 350°F for 8 to 10 minutes. Let cool while preparing filling. Clean bowl and paddle.

Place the cream cheese in the Cuisinart™ mixing bowl and stir on speed 1 until just smooth, about 1 minute. Add sugar, ¼ cup at a time. Stir on speed 2 until smooth, about 30 seconds after each addition. Scrape the bottom and sides of the bowl and the beater after adding half the sugar. Mixing on speed 2, add the eggs, one at a time, mixing about 30 seconds after each addition. Scrape the bottom and sides of the bowl and the paddle after adding 2 eggs, then again after adding 5 eggs, and again after all 7 eggs have been added. Add the vanilla, mix on speed 1 until creamy and homogenous, about 1 minute. Pour all except about 2½ cups of the batter into cooled prepared crust – do not scrape any thick bits from the sides of the bowl as they are not thoroughly mixed in and will change the texture of your finished cheesecake. Stir the melted and cooled chocolate into the remaining batter. Drop chocolate mixture onto cream cheese mixture, ¼ cup at a time. Draw swirls with a knife or spatula to create a marbled effect.

Place the pan in a jelly-roll pan or roasting pan. Place on oven rack and pour hot water into the bottom pan to a depth of at least ½ inch to create a water bath. Bake the cheesecake in preheated 350°F oven for 1 hour and 15 minutes. The center of the cheesecake will still be slightly jiggly.

Remove from oven, remove foil and cool on a wire rack for 1 hour. Refrigerate, uncovered until cold, then cover. Refrigerate for 6 hours or longer before serving.

