

SONY®

IC Recorder

Operating Instructions

Click! You can direct jump

Table of Contents

Recording Files

Utilizing Your Computer

Troubleshooting

Index

GB

4-300-042-11(1)

Table of Contents

WARNING	5
Notice for users	7

Preparing the recorder

Checking the Parts and Controls	8
Using the Display Window.....	10
Preventing Unintentional Operations (HOLD)	16
Maintaining the Moderate Volume Level(For European models only)	17
Recharging the Battery.....	18
Recharging the battery using a computer	18
Recharging the battery using a USB AC adaptor	19
Turning the IC Recorder On	20
Turning the power on.....	20
Turning the power off	20
Using the standby function.....	20
Using the power saving mode	21
Setting the Clock	22
Setting the clock after recharging the battery	22
Setting the clock using the menu.....	23
Setting the Language to Be Used in the Display Window	25
About the Home menu	26
How to use the Home menu.....	27
Selecting a File.....	28
Selecting a file using the menu.....	28
Selecting a file in the stop or playback mode window	30
Displaying the file information	31
Inserting a microSD Card	32
Selecting the memory	34

Recording Files

Basic Recording.....	35
Monitoring the recording	36
Stopping the recording	37
Other operations	37
Changing the Recording Settings	38
Selecting the recording destination folder.....	38
Selecting a recording scene for each situation	39

Tips for better recording	40
Changing the Scene Select settings.....	41
Changing the Scene Select setting to the default values	42

Starting to Record Automatically in Response to Sound – the VOR Function	43
--	----

Playing Files

Basic Playback	44
Stopping playback.....	44
Other operations.....	45
Changing the Playback Settings.....	46
Reducing noise or selecting the sound effect in playback – the Effect function	46
Adjusting the playback speed – the DPC (Digital Pitch Control) function	48
Selecting the play mode	49
Convenient Playback Methods.....	50
Listening with better sound quality.....	50
Searching forward/backward during playback (Cue/Review)	50
Locating the point you wish to start playback quickly – the Easy Search function.....	51
Playing Back a File at a Desired Time with an Alarm.....	52

Erasing Files

Erasing a File	54
Erasing All Files in a Folder	56

Editing Files

Arranging Files in a Folder	57
Moving a file to a different folder	57
Copying a file to the other memory	58
Using a Track Mark	60
Adding a track mark.....	60
Erasing a track mark.....	61
Erasing all the track marks in the selected file at one time.....	62
Dividing a File	63
Dividing a file at the current position	63
Dividing a file at all the track mark positions	64

Renaming a Folder and a File.....	65
Changing a folder name.....	65
Changing a file name.....	66
Protecting a File.....	67

About the Menu Function

Menu Operation Modes	68
Menu Settings	70

Utilizing Your Computer

Using the IC Recorder with Your Computer	79
Connecting the IC recorder to your computer	80
Structure of folders and files.....	81
Disconnecting the IC recorder from your computer	84

Copying Files from the IC Recorder to Your Computer.....	85
---	-----------

Copying Music Files from Your Computer to the IC Recorder and Playing Them Back	86
Copying a music file from your computer to the IC recorder (drag and drop)	86
Playing back music files copied from your computer using the IC recorder	87

Using the IC Recorder as USB Memory	88
--	-----------

Using the Supplied Sound Organizer Software.....	89
What you can do using Sound Organizer.....	89
System requirements for your computer	91
Installing Sound Organizer	92
The Sound Organizer window	94

Additional Information

Using a USB AC Adaptor.....	95
Disconnecting the IC recorder from the AC outlet.....	96
Precautions	97
Specifications.....	99
System requirements	99
Design and specifications	101
Battery life.....	103

Troubleshooting

Troubleshooting	104
On the IC recorder operations	105
On the Sound Organizer	110
Messages List	112
System Limitations	116
Trademarks.....	117
Listening for a Lifetime.....	118
Index	120

Browsing the Operation Guide

To use the buttons in the Operation Guide

Click the buttons located in the upper right of the pages of this manual to jump to “Table of Contents,” or “Index.”

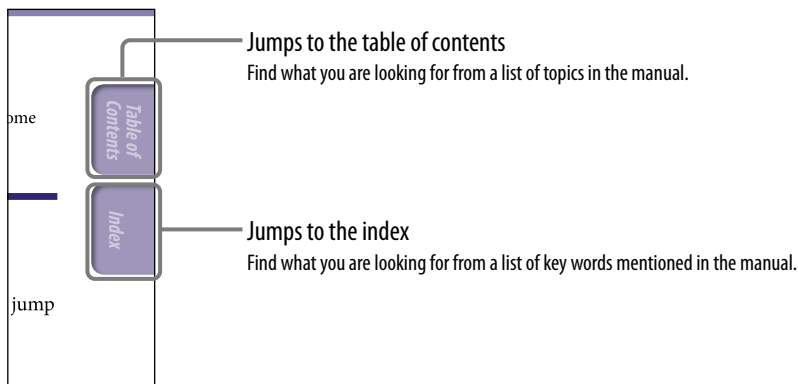

Hints

- You can jump to the indicated page by clicking a page number in the table of contents or in the index.
- You can jump to the indicated page by clicking a page reference indication (e.g.,  p. 6) on each page.
- To search for a reference page by keyword, enter the keyword into the find text field on the Adobe Reader window.
- Operation procedures may differ, depending on your Adobe Reader version.

To change the page layout

The buttons on the Adobe Reader window enable you to select how pages are displayed.



Continuous

Pages are displayed as a continuous roll of pages, fitting the page width inside the window. When you scroll, the previous or next pages scroll up or down continuously.

Single Page

Pages are displayed one at a time, fitting the page into the window. When you scroll, the display changes to the previous or next page.

WARNING

Do not expose the batteries (battery pack or batteries installed) to excessive heat such as sunshine, fire or the like for a long time.

- The recorded music is limited to private use only. Use of the music beyond this limit requires permission of the copyright holders.
- Sony is not responsible for incomplete recording/downloading or damaged data due to problems of the IC recorder or computer.
- Depending on the types of the text and characters, the text shown on the IC recorder may not be displayed properly on device. This is due to:
 - The capacity of the connected IC recorder.
 - The IC recorder is not functioning normally.
 - Content information is written in the language or the character that is not supported by the IC recorder.

At high volume, prolonged listening to the personal audio player can damage the user's hearing.

(For France only)

**For the customers in Europe**

To prevent possible hearing damage, do not listen at high volume levels for long periods.

**Disposal of Old Electrical & Electronic Equipment (Applicable in the European Union and other European countries with separate collection systems)**

This symbol on the product or on its packaging indicates that this product shall not be treated as household waste. Instead it shall be handed over to the applicable collection point for the recycling of electrical and electronic equipment. By ensuring this product is disposed of correctly, you will help prevent potential negative consequences for the environment and human health, which could otherwise be caused by inappropriate waste handling of this product. The recycling of materials will help to conserve natural resources. For more detailed information about recycling of this product, please contact your local Civic Office, your household waste disposal service or the shop where you purchased the product.

Applicable accessory: Headphones

Disposal of waste batteries (applicable in the European Union and other European countries with separate collection systems)



This symbol on the battery or on the packaging indicates that the battery provided with this product shall not be treated as household waste.

On certain batteries this symbol might be used in combination with a chemical symbol. The chemical symbols for mercury (Hg) or lead (Pb) are added if the battery contains more than 0.0005% mercury or 0.004% lead.

By ensuring these batteries are disposed of correctly, you will help prevent potentially negative consequences for the environment and human health which could otherwise be caused by inappropriate waste handling of the battery. The recycling of the materials will help to conserve natural resources.

In case of products that for safety, performance or data integrity reasons require a permanent connection with an incorporated battery, this battery should be replaced by qualified service staff only.

To ensure that the battery will be treated properly, hand over the product at end-of-life to the applicable collection point for the recycling of electrical and electronic equipment.

For all other batteries, please view the section on how to remove the battery from the product safely. Hand the battery over to the applicable collection point for the recycling of waste batteries.

For more detailed information about recycling of this product or battery, please contact your local Civic Office, your household waste disposal service or the shop where you purchased the product.

Notice for the customers: the following information is only applicable to equipment sold in the countries applying EU directives

The manufacturer of this product is Sony Corporation, 1-7-1 Konan Minato-ku Tokyo, 108-0075 Japan. The Authorized Representative for EMC and product safety is Sony Deutschland GmbH, Hedelfinger Strasse 61, 70327 Stuttgart, Germany. For any service or guarantee matters please refer to the addresses given in separate service or guarantee documents.

Notice for users

All rights reserved. This manual or the software described herein, in whole or in part, may not be reproduced, translated or reduced to any machine readable form without prior written approval from Sony Corporation.

IN NO EVENT SHALL SONY CORPORATION BE LIABLE FOR ANY INCIDENTAL, CONSEQUENTIAL OR SPECIAL DAMAGES, WHETHER BASED ON TORT, CONTRACT, OR OTHERWISE, ARISING OUT OF OR IN CONNECTION WITH THIS MANUAL, THE SOFTWARE OR OTHER INFORMATION CONTAINED HEREIN OR THE USE THEREOF.

Sony Corporation reserves the right to make any modification to this manual or the information contained herein at any time without notice.

- The software described herein may also be governed by the terms of a separate user license agreement.
- This software is for Windows and cannot be used for Macintosh.
- The supplied connection cable is for the IC recorder ICD-TX50. You cannot connect other IC recorders.
- Display windows in this manual may differ from what are actually displayed on your IC recorder depending on the area you purchased the IC recorder and the settings you have made.

What you record is for personal enjoyment and use only. Copyright laws prohibit other forms of use without the permission of the copyright holders.

Checking the Parts and Controls

Front

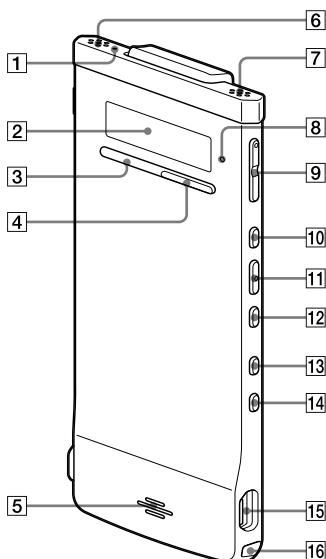

- 1** Recording indicator
- 2** Display window
- 3** ■ STOP button
- 4** ● REC (record)/PAUSE button
- 5** Speaker
- 6** Built-in microphone (stereo) (L)
- 7** Built-in microphone (stereo) (R)
- 8** Operation indicator
- 9** VOL (volume) -/+* button
- 10** ►►I (fast forward/up) button
- 11** ►/ENT (play/enter) button*

- 12** I◀◀ (fast backward/down) button
- 13** BACK/HOME (back/home menu) button
- 14** T-MARK (Track mark) button
- 15** USB (USB) connector
- 16** Strap hole
(A strap is not supplied.)

* These buttons and the jack have a tactile dot. Use it as a reference point for operations, or to identify each terminal.

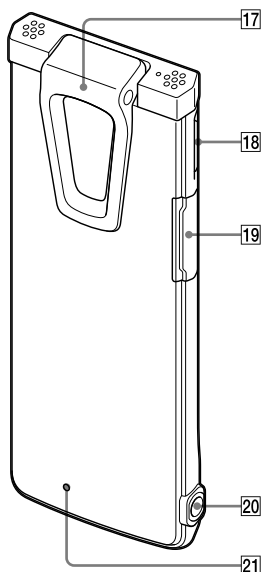
Rear**17** Clip**18** POWER-HOLD switch**19** microSD card slot**20** (headphone) jack**21** RESET button

You can reset the IC recorder by pressing the button with a small pin, etc. (☞ p. 104).

Attaching the noise damper

By attaching the noise damper to the IC recorder, you can reduce vibration noises from a table or other surface where the IC recorder is placed.

Align the lower part of the noise damper to the recorder at an angle (①), and then press the logo part (②), so that the noise damper clicks in place.

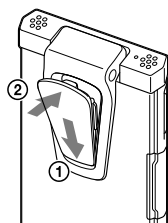
**💡 To remove the noise damper**

Lift the upper part of the noise damper (in the reverse direction as described in ②), and then remove it.

💡 Tip

The noise damper is for decreasing the possible noise from a table. When you attach the IC recorder to your clothes, remove the noise damper from the IC recorder.

Using the Display Window

Display when stopped

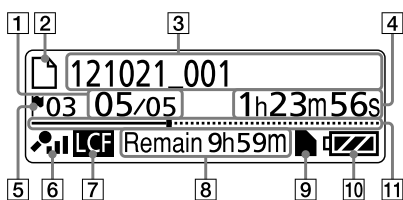

Note

The above window and the other windows in this section display indications, numbers, or items for explanatory purposes. The actual windows may differ from those displayed here.

1 File location indication

The selected file number is displayed in the numerator and the total number of files in the folder is displayed in the denominator.

2 File indicator

3 Fine name indication

Recorded date(year/month/day)_number (e.g., 121021_001)

4 Counter (elapsed time) indication

In the stop mode: The current position (the elapsed time from the beginning of the current file)

In the playback mode: The elapsed playback time of the current file

In the recording mode: The cumulative recording time of the current file

5 Track mark indicator

Displays the track mark number just before the current position. Appears when a track mark is set for a file.

6 Microphone sensitivity/scene select setting indicator

Displays the currently selected microphone sensitivity or scene setting used for recording.

Microphone sensitivity:

🔊: High

🔊: Medium

🔊: Low

Scene select setting:

👔: Shirt Pocket

🗣️: Meeting

🗣️: Voice Notes

🎙️: Interview

🎙️: My Scene

7 LCF (Low Cut Filter) indicator

Appears when “LCF(Low Cut)” is set to “ON” in the menu.

8 Remaining recording time

Displays the remaining recording time in hours, minutes, and seconds.

If there is 10 hours or more time remaining, the time is displayed in hours.

If there is 10 minutes or more and less than 10 hours time remaining, the time is displayed in hours and minutes.

If there is less than 10 minutes time remaining, the time is displayed in minutes and seconds. (The indicator flashes during recording.)

9 microSD card indication

Appears when a microSD card is inserted and “Select Memory” in the menu is set to “microSD Card.” When “Built-In Memory” is selected, no indication is displayed.

10 Battery indicator

Displays the remaining battery power. As the battery power is depleted, the bars of the icon disappears, one by one.

11 Progress bar (time line)

Displays the current stop or playback position as a marker on the time line from the left start point to the right end point of the current file.

Display of current file information**12 Title name indication**

Recorded date(year/month/day)_number (e.g., 121021_001) or a registered title name

13 Artist name indication

Artist name (e.g., My Recording) or a registered artist name.

14 Recorded date and time indication

Displays the recorded date (year/month/day) and time (hour/minute).

15 File format indication

The file format and other pieces of information such as bit rate, “VBR,” or “MONO” are displayed. When the IC recorder cannot get the file format information of a file, the file format is displayed as “--- ---.”

16 Protect indicator

Appears when protection is set for a file.

17 Alarm indicator

Appears when an alarm is set in a file.

18 Newly arriving podcast indication**19 Editorial message indication**

When some editorial functions are disabled for a file, a message is displayed (e.g., Cannot Divide File or Edit Track Mark).

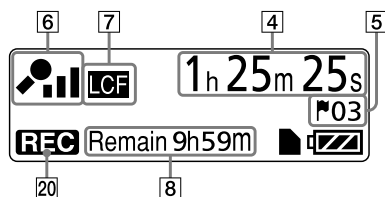
Display when recording**20 Operation mode indicator**

Displays the following, depending on the current operation of the IC recorder.

- ▶** : playback
- REC** : recording
- ⏏** : recording pause (flashing)
- VOR** : recording with the VOR function, or recording pause with the VOR function (flashing)
- ⏮ ▶** : fast backward (review), fast forward (cue)

Display during playback

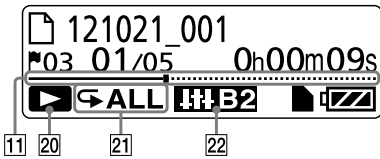

21 Play mode /DPC/Alarm indicator

- 1: Appears when a file is played back.
- 📁: Appears when files in one folder are played back continuously.
- ALL: Appears when all the files are played back continuously.
- ↶ 1: Appears when one file is played back repeatedly.
- ↶ 📁: Appears when files in one folder are played back repeatedly.
- ↶ ALL: Appears when all the files are played back repeatedly.
- DPC x1.20**: DPC (Digital Pitch Control) playback (specified playback speed)
- ALARM**: Alarm playback

22 Effect indicator

Appears when the sound quality is set with “Effect” in the menu.

Voice1: Clear Voice 1

Voice2: Clear Voice 2

HP: Music: Pop

HR: Music: Rock

HJ: Music: Jazz

HB1: Music: Bass 1

HB2: Music: Bass 2

Display in the HOLD status

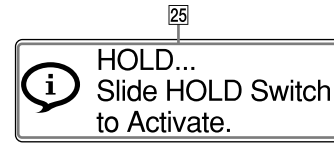

23 HOLD indicator

Appears when the IC recorder enters the HOLD status to prevent unintentional operations. All the button operations are disabled.

24 Current time indication

Displays the current time when the IC recorder entered the HOLD status.

(e.g., 12:00 (24-Hour time display)/12:00 PM (12-Hour time display))

25 Hold indication

Appears when you perform a button operation while the IC recorder is in the HOLD status.

To release the HOLD status, slide the POWER•HOLD switch towards the center (🔍 p. 16).

Display during file selection

Category list



Folder list

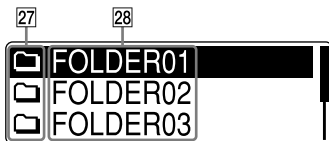

File list

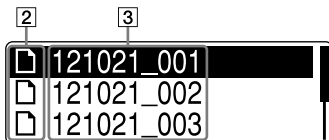

26 Category indication

Folders containing files are categorized into recordable or playback-only area for managing files.

- ☎ Recording Files: Recordable area. Used to manage files recorded with the IC recorder.
- 🎵 Music: Playback-only area. Used to manage music files transferred from your computer. You can use only a limited number of editorial functions.
- 🎙 Podcast: Playback-only area. Used to manage podcast files transferred from your computer. You cannot use any editorial functions, except for deletion.

27 Folder indication

- 📁 : A folder where you can record a file
- 📁 : A folder for playback only
- 🎙 : A folder for podcast files

28 Folder name

FOLDER01 to FOLDER05, or specified folder name is displayed.

Display during MENU operation

Home menu

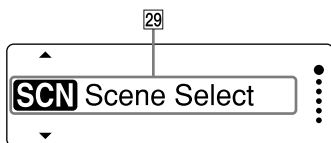

Menu setting

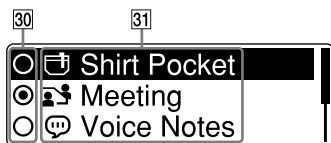

29 Home menu

The Home menu consists of the following five items, each representing a major feature of the IC recorder.

SCN Scene Select

□ Select File

🗑 Erase Files

✎ Edit

⚙ Settings

💡 Hint

By selecting the following menu and pressing ►/ENT, you can go back to the window that was displayed before you entered the menu mode:

□, and one of the following items appears, depending on the operation you performed before you entered the menu mode: To Stop Screen/Return to Playback/Return to REC

30 Item selection buttons

Press ◀◀ or ▶▶ to select an item, and then press ►/ENT to confirm.

31 Menu items

The items of the selected menu are displayed.

Preventing Unintentional Operations (HOLD)

You can disable all the buttons (HOLD) in order to prevent unintentional operations when you carry the IC recorder, etc.

To disable the button operations (HOLD status)

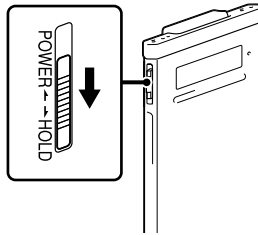

Slide the POWER•HOLD switch in the direction of “HOLD” to disable the buttons while the power is on.

“HOLD” and the current time will appear for approximately 3 seconds, indicating that all the button operations are disabled.

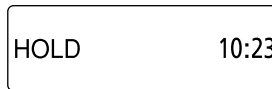

To enable the button operations

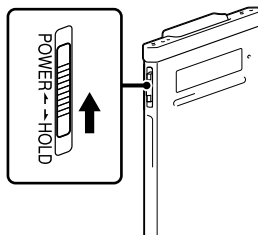

Slide the POWER•HOLD switch towards the center.

Note

When the HOLD function is activated during recording, all the button operations are disabled. To stop recording, cancel the HOLD function first.

Hint

Even if the HOLD function is activated, you can stop the alarm playback by pressing any button. (You cannot stop normal playback.)

Maintaining the Moderate Volume Level (For European models only)

The IC recorder limits the maximum volume to allow you to listen to the sound at a moderate volume level when using the headphones. When you try to adjust the volume to a level that exceeds the specified level, the “Check The Volume Level” message appears.

 Check The
Volume Level

Press /ENT, then adjust the volume.

Note

The volume is lowered automatically and the “Volume Lowered” message appears, if you do not lower the volume for approximately 20 hours after the “Check The Volume Level” message appears.

 Volume Lowered

Recharging the Battery

Recharging the battery using a computer

1 Connect the IC recorder to your computer.

Use the USB connecting cable supplied with the IC recorder to connect the Ψ (USB) connector of the IC recorder and the USB port of a running computer.

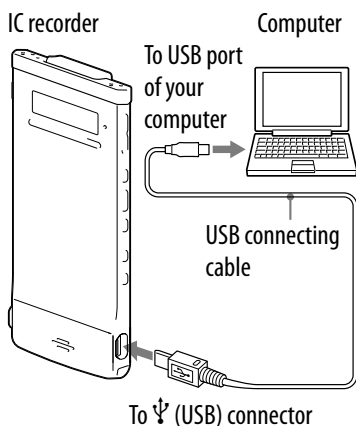

While the battery is charging, “Connecting” and the battery indicator are displayed in an animation.

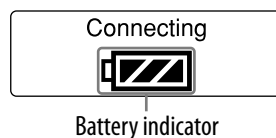

When the battery is fully charged, the battery indicator will indicate “FULL.” It takes about 1 hour and 30 minutes to fully charge an exhausted battery.*¹

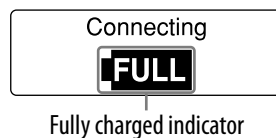

When you use the IC recorder for the first time, or if you have not used the IC recorder for a long time, recharge it fully until the “FULL” battery indicator appears.

2 Disconnect the IC recorder from your computer.

Follow the procedures below; otherwise, when the IC recorder contains data files, the files may be damaged or become unplayable.

① Make sure that the operation indicator does not light.

② Perform the following operation on your computer.*²

On the Windows taskbar at the bottom right of the desktop, left-click the following icon:



➤ Left-click “Eject IC RECORDER” (Windows 7), or “Safely remove USB Mass Storage Device” (Windows XP, Windows Vista).

The icon and menu displayed can be different on different operating systems. The icon may not always be displayed on the taskbar, depending on your computer settings.

On a Macintosh screen, click the “IC RECORDER” or “MEMORY CARD” ejection icon on the Finder side bar.

③ Remove the USB connecting cable from your computer and the IC recorder.

*¹ This is an approximation for the time it takes to charge from no remaining battery power to full battery power at room temperature. It varies depending on the remaining power and the condition of the battery.

*² For details on disconnecting the IC recorder from your computer, refer to the operating instructions supplied with your computer.

Recharging the battery using a USB AC adaptor

You can also charge the battery by using a USB AC adaptor (not supplied) (☞ p. 95).

Turning the IC Recorder On

Turning the power on

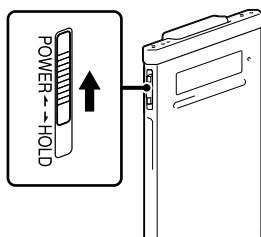

Slide and hold the POWER•HOLD switch in the direction of “POWER” until the window display appears. The IC recorder is turned on.

Turning the power off

Slide and hold the POWER•HOLD switch in the direction of the “POWER” until the “Power Off” animation is displayed. The IC recorder is turned off.

Hint

If there is no operation attempted for approximately 5 seconds in the stop mode, the display turns off automatically (in the power saving mode). If there is no further operation attempted for approximately 10 minutes, the IC recorder turns off completely (automatic power-off function).

Using the standby function

Slide the POWER•HOLD switch in the direction of “HOLD” in the stop mode. The IC recorder enters the standby mode, minimizing the battery consumption of the IC recorder. You can resume operations immediately after you release the HOLD status by sliding the POWER•HOLD switch in the direction of “POWER.” This function is useful when you want to wake up the IC recorder quickly.

Hint

In the normal stop mode, the IC recorder turns off automatically if there is no operation attempted for 10 minutes. In the standby mode, on the other hand, the IC recorder turns off automatically if there is no operation attempted for 24 hours.

Using the power saving mode

To save battery power, the power saving mode is set to “ON” by default. In the power saving mode, if no operation is attempted for approximately 5 seconds in the stop mode and for approximately 10 seconds in the recording and playback modes, the display turns off automatically. You can perform a button operation, however, even while the display is turned off. To turn on the display, press BACK/HOME.

Hint

To disable the power saving mode, press and hold BACK/HOME until the Home menu appears, and then select “ Settings” – “Common Settings” – “Power Saving Mode.” Set “Power Saving Mode” to “OFF.”

Setting the Clock

You need to set the clock to use the alarm function or record the date and time.

Setting the clock after recharging the battery

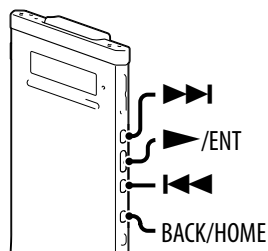

When the clock is not set after you purchased the IC recorder and use it for the first time, the “Set Date&Time” message appears and then the “Set Date&Time?” confirmation message appears.

1 Press or to select “YES,” and then press /ENT.

The clock setting window is displayed and the year section begins to flash.

2 Set year, month, day, hour and minute.

Press or to set the year, and then press /ENT. Repeat this procedure to set month, day, hour, and minute in sequence.

You can move the cursor back to an item by pressing BACK/HOME.

When you set the minute and press /ENT, the “Please Wait” animation appears and the clock is set.

2012	y	1	m	1	d
		0	:	00	

Setting the clock using the menu

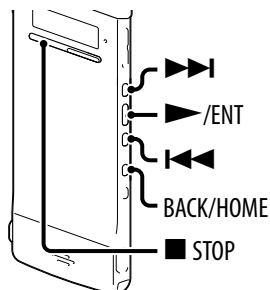

While the IC recorder is in the stop mode, you can set the clock using the menu.

1 Select "Date&Time" in the menu.

① In the stop mode, press and hold BACK/HOME until the Home menu appears.

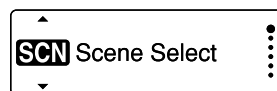

② Press ◀◀ or ▶▶ to select "Settings," and then press ▶/ENT.

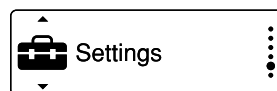

③ Press ◀◀ or ▶▶ to select "Common Settings," and then press ▶/ENT.

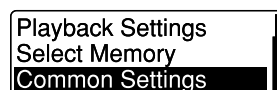

④ Press ◀◀ or ▶▶ to select "Date&Time," and then press ▶/ENT.

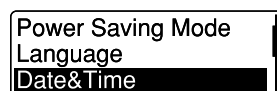

2 Press ◀◀ or ▶▶ to select "Auto(Synchronizing)" or "Manual," and then press ▶/ENT.



When you select "Auto(Synchronizing)," the clock is automatically adjusted using the clock in the computer connected to the IC recorder and on which the supplied Sound Organizer software is started.

When you select "Manual," proceed to the next step.

3 Set year, month, day, hour and minute.

Press **◀◀** or **▶▶** to set the year, and then press **▶**/ENT. Repeat this procedure to set month, day, hour, and minute in sequence.

You can move the cursor back to an item by pressing BACK/HOME.

When you set the minute and press **▶**/ENT, the “Please Wait” animation appears and the clock is set.

2012	y	1	m	1	d
		0	:	00	

4 Press **■ STOP to exit the menu mode.****Notes**

- If you do not press **▶**/ENT within 1 minute of entering the clock setting data, the clock setting mode is canceled and the window will return to the display of the stop mode.
- The time is displayed either in 12-Hour mode with “AM” or “PM,” or in 24-Hour mode, depending on the “Time Display” setting in the menu. The default setting differs, depending on the region where you purchased the IC recorder.

Setting the Language to Be Used in the Display Window

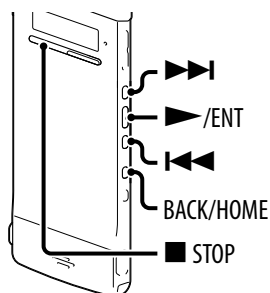

You can select the language to be used for messages, menus, folder names, file names, etc.

- 1** In the stop mode, press and hold **BACK/HOME** to display the Home menu, then select "**Settings**" → "**Common Settings**" → "**Language**," and then press **▶/ENT**.

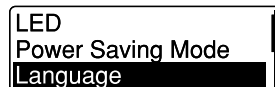

- 2** Press **◀◀** or **▶▶** to select the language that you want to use, and then press **▶/ENT**.
- 3** Press **■ STOP** to exit the menu mode.

About the Home menu

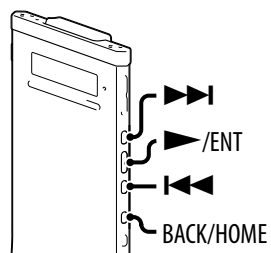

You can display the Home menu by pressing and holding BACK/HOME. The Home menu is the starting point of each feature of the IC recorder, such as editing or making various settings.

Home menu



The Home menu consists of the following five items. Press ◀◀ or ▶▶ to select a Home menu item, and then press ▶/ENT to confirm:

SCN Scene Select

□ Select File

🗑 Erase Files

✎ Edit

👜 Settings

How to use the Home menu

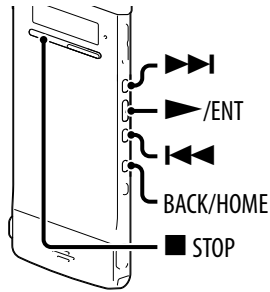

When you press **◀◀** or **▶▶** to select an item and then press **▶**/ENT, you can display the menu window one-layer down. Pressing BACK/HOME button returns to the menu window one-layer up. Whichever layer of a menu window you display, you can go back directly to the Home “Scene Select” menu window by pressing and holding BACK/HOME.

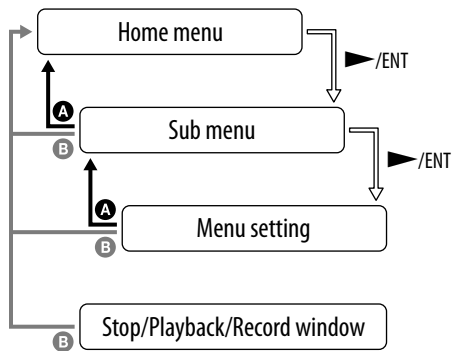

- A** BACK: Press BACK/HOME.
- B** HOME: Press and hold BACK/HOME.

To exit the Home menu, press **■** STOP.

Selecting a File

Selecting a file using the menu

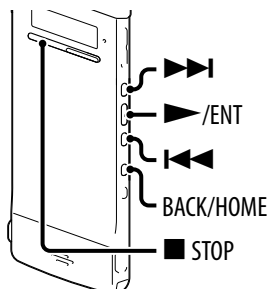

You can select a folder and a file for recording, playing, or editing as follows:

1 Display the “Select File” menu.

- ① In the stop or playback mode, press and hold **BACK/HOME** until the Home menu appears.
- ② Press **◀◀** or **▶▶** to select “Select File,” and then press **▶/ENT**.

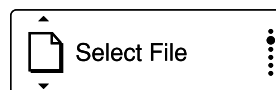

2 Select a category.

Press **◀◀** or **▶▶** to select “Recording Files,” “Music,” or “Podcast,” and then press **▶/ENT**.



Note

When you purchase the IC recorder, you can select the “Recording Files” category only. You cannot select the other categories because there are no files currently saved in the categories. When you transfer files from your computer, you can display folders for those categories.

3 Select a folder.

When you purchase the IC recorder, there are 5 folders already available (FOLDER01-05) in the “Recording Files” category.

Press **◀◀** or **▶▶** to select the desired folder, and then press **▶/ENT**.



4 Select a file.

Press **⏪** or **⏩** to select the desired file, and then press **▶/ENT**.

The playback mode window of the selected file is displayed.

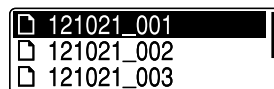

5 Press ■ STOP to stop playback.

You can switch files by pressing **⏪** or **⏩**.

Selecting a file in the stop or playback mode window

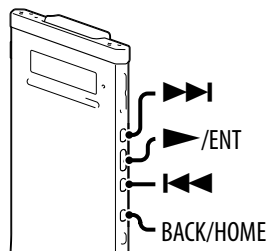

In the stop or playback mode, press BACK/HOME.

The file list of the current folder is displayed. By pressing BACK/HOME repeatedly, you can display the folder list, category list, and the “Select File” window in sequence.

In each window, you can press ◀◀ or ▶▶ to select an item and then press ▶/ENT to confirm.

Note

When you display a folder list during playback, playback stops.

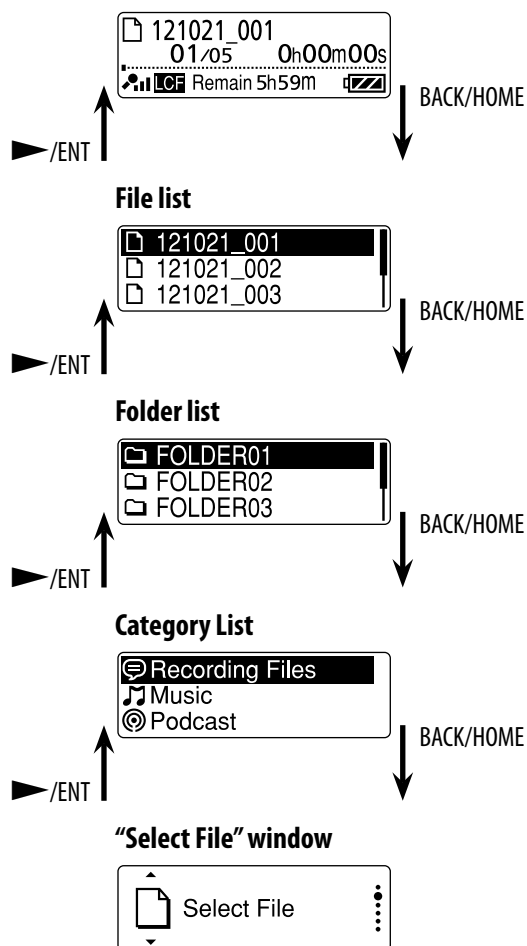

Displaying the file information

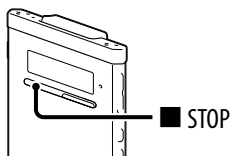

You can display the file information of the current file by pressing ■ STOP in the stop mode. By pressing ■ STOP repeatedly, you can display the rest of the file information, and then return to the stop mode window.

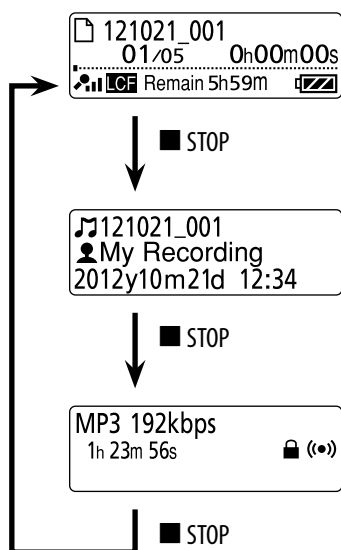

Inserting a microSD Card

In addition to the built-in memory, you can record files on a microSD card. In this manual, microSD cards and microSDHC cards are generally referred to as a “microSD card.”

- 1 In the stop mode, open the lid of the microSD card slot, and then insert a microSD card into the microSD card slot as illustrated below until it clicks into place.**

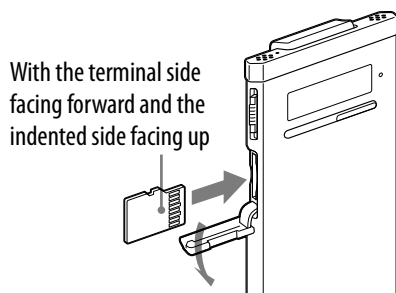

To remove a microSD card

In the stop mode, push the microSD card into the slot. When it pops out, remove it from the microSD card slot.

Structure of folders and files

5 folders are created in a microSD card in addition to those in the built-in memory. The structure of folders and files is somewhat different from that of the built-in memory (🔗 p. 81).

Notes

- If a microSD card is not recognized, remove it and then insert it into the IC recorder again.
- Do not insert any liquid, metal, flammable or any object other than a microSD card into the microSD card slot. Doing so may cause fire, electric shock, or malfunctions.
- Before recording, we recommend that you copy all the data stored on the microSD card to your computer and format the microSD card on the IC recorder so it contains no data.

About compatible microSD cards

You can use microSD/microSDHC cards with the IC recorder.

Due to the file system specifications of the IC recorder, you can record and play back an LPCM file smaller than 2 GB, and an MP3/WMA/AAC-LC file smaller than 1 GB using a microSD card.

Note

Operations of all types of compatible microSD cards are not guaranteed.

Selecting the memory

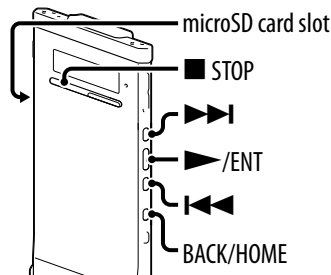

You can switch the memory between the built-in memory and a microSD card by using the menu:

- 1 To switch the memory to the microSD card, insert a microSD card into the microSD card slot (🔗 p. 32).**

- 2 In the stop mode, press and hold BACK/HOME to display the Home menu, then select "⚙ Settings" → "Select Memory," and then press ►/ENT.**



- 3 Press ◀◀ or ▶▶ to select "microSD Card" or "Built-In Memory," and then press ►/ENT.**



If you select "microSD Card" and the microSD card has not been formatted, proceed to the next step. Otherwise, proceed to step 6.

- 4 When the microSD card is not formatted, press and hold BACK/HOME to display the Home menu, then select "⚙ Settings" → "Common Settings" → "Format," and then press ►/ENT.**

"All Data in microSD Card Will be Erased" is displayed. Then "Execute?" will be displayed.

- 5 Press ◀◀ or ▶▶ to select "YES," and then press ►/ENT.**

The "Please Wait" animation appears, and the microSD card is formatted.

- 6 Press ■ STOP to exit the menu mode.**

When you select "microSD Card," the microSD card icon ■ is displayed.

Basic Recording

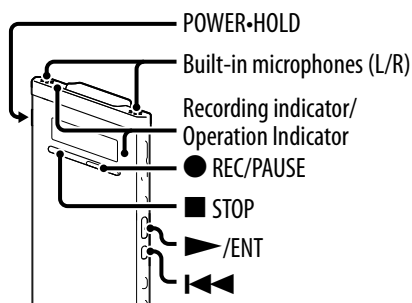

The following are the basic recording procedures using the specified microphone sensitivity and recording mode.

Note

Noise may be recorded if an object, such as your finger, etc., accidentally rubs or scratches the IC recorder during recording.

Hint

Before you start recording, we recommend you make a trial recording first, or monitor the recording (🔗 p. 36).

- 1 **Slide the POWER•HOLD switch in the direction of “POWER” to turn on the IC recorder (🔗 p. 20), or towards the center to release the IC recorder from the HOLD status (🔗 p. 16).**

The stop mode window appears.

- 2 **Select the desired destination folder in the menu (🔗 p.38).**

Tip

If you do not set a destination folder, a file will be recorded in “FOLDER01” in the “🗨 Recording Files” category of the built-in memory or the microSD card.

- 3 **To record with the IC recorder in a shirt pocket, place the IC recorder in the pocket, secured with the clip.**

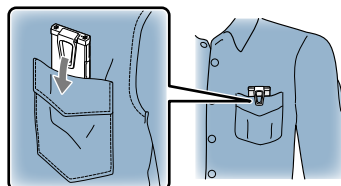

To record with the IC recorder on a table or other surface, attach the supplied noise damper to the IC recorder and place the IC recorder so that the built-in microphones face the direction of the source to be recorded.



4 In the stop mode, press ● REC/PAUSE.

The recording indicator and the operation indicator light in red.

You do not need to press and hold ● REC/PAUSE while recording.

The new file will be automatically recorded as the last file in the specified destination folder.

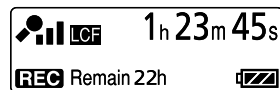

Hint

You can select a recording scene setting such as “Shirt Pocket” or “Interview” that suits the recording situation (☞ p. 39).

Monitoring the recording

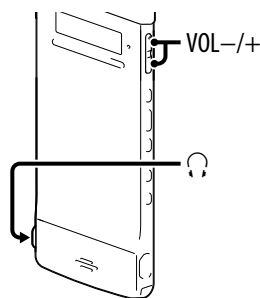

If you connect the supplied stereo headphones to the  (headphone) jack, you can monitor the recording. You can adjust the monitoring volume by pressing VOL -/+, but the recording level is fixed.

Stopping the recording

1 Press **■** STOP.

The “Please Wait” animation appears on the display and the operation indicator flashes in orange. The IC recorder stops at the beginning of the current recording file.

Note while accessing

The IC recorder is recording data and storing it on the memory media when the “Please Wait” animation appears on the display, or the operation indicator flashes in orange. While the IC recorder is accessing data, do not remove a microSD card or press the RESET button. Also, do not disconnect or connect the USB AC adaptor (not supplied) when you are using the USB AC adaptor. Doing so may damage the data.

Other operations

To	Do this
pause recording*	Press ● REC/PAUSE. During recording pause, the recording indicator and operation indicator flash in red and “ ● ” and the counter indication begins to flash in the display window.
release pause and resume recording	Press ● REC/PAUSE again. Recording resumes from that point. (To stop recording after pausing recording, press ■ STOP.)
review the current recording instantly	Press ▶ /ENT. Recording stops and playback starts from the beginning of the file just recorded.
review during recording	Press and hold ◀◀ during recording or recording pause. Recording stops and you can search backwards while listening to fast playback sound. After you release ◀◀ , playback starts from that point.

* 1 hour after you pause recording, recording pause is automatically released and the IC recorder enters the stop mode.

Hint

You can make new folders or erase unwanted folders using the supplied Sound Organizer software ( p. 89).

Changing the Recording Settings

Selecting the recording destination folder

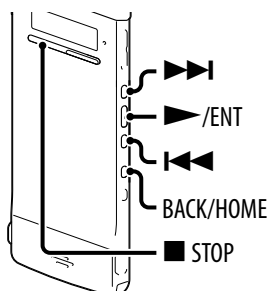

You can set the folder in which a recording file is saved. You can select a folder in the “☰ Recording Files” category each for the built-in memory and microSD card.

- 1 In the stop mode, press and hold BACK/HOME to display the Home menu, then select “☰ Settings” → “Recording Settings,” and then press ►/ENT.**



- 2 Press ◀◀ or ▶▶ to select “Save Destination,” and then press ►/ENT.**

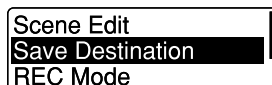

- 3 Press ◀◀ or ▶▶ to select the desired destination folder, and then press ►/ENT.**



- 4 Press ■ STOP to exit the menu mode.**

Hint

If the specified destination folder is filled with the maximum number of files when you start recording, the destination folder is automatically switched to another available folder and the file will be recorded in that folder.

If this occurs, a message notifying you that the destination folder has been changed will be displayed when you stop recording.

Selecting a recording scene for each situation

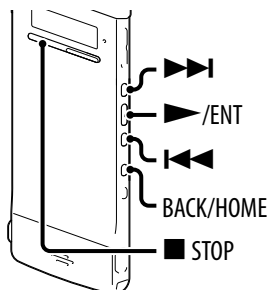

According to various recording scene, you can change the items for recording, such as REC Mode (🔧 p. 72), Mic Sensitivity (🔧 p. 73), etc., to the recommended settings in bulk. You can change the settings for each item.

- 1 In the stop or playback mode, press and hold BACK/HOME until the Home menu appears.**

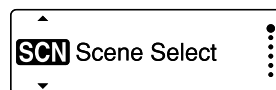

- 2 Press ►/ENT.**

The scene select setting window is displayed.

- 3 Press ◀◀ or ▶▶ to select a scene you want, and then press ►/ENT.**



- 4 Press ■ STOP to exit the menu mode.**

Scenes	Descriptions
👔 Shirt Pocket	To record with the IC recorder in a shirt pocket.
🗣 Meeting	To record in a variety of situations, such as recording in a spacious conference room.
🗣 Voice Notes	To record dictation with a microphone in front of your mouth.
🗣 Interview	To record human voice at a distance of 1 to 2 meters (40 to 80 in.).
📁 My Scene	Use to keep your favorite settings.

Tips for better recording

There are ways of making better recordings other than using scene selection.

Recording at a meeting

When recording with the IC recorder placed on a table, you can reduce noise by attaching the supplied noise damper to the IC recorder. By placing the IC recorder on a handkerchief, etc., you can also record with clear, low-noise sound, minimizing vibration noise from the desk.



Recording a voice note

By placing the IC recorder close to one side of your mouth, you can prevent breathing on the built-in microphones, and record with clear sound.



Recording an interview

Place the IC recorder so that the built-in microphones face the interviewee.



Recording with the IC recorder in a shirt pocket

By inserting the IC recorder in a shirt pocket, secured with the clip, you can reduce the noise that may be caused if cloth, etc., accidentally rubs the IC recorder during recording.

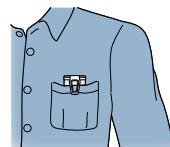

Changing the Scene Select settings



- 1 In the stop or playback mode, press and hold BACK/HOME to display the Home menu, then select “ Settings” → “Recording Settings” → “Scene Edit,” and then press ►/ENT.

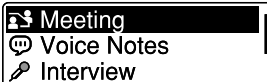

Scene Edit
Save Destination
REC Mode

- 2 Press ◀◀ or ▶▶ to select the scene you want to change the settings, and then press ►/ENT.



 Meeting
 Voice Notes
 Interview

- 3 Press ◀◀ or ▶▶ to select “Edit” or “Edit from Current Setting,” and then press ►/ENT.

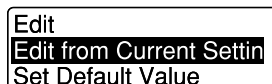

Edit
Edit from Current Setting
Set Default Value

- 4 Press ◀◀ or ▶▶ to select the item you want to change, and then press ►/ENT.



Edit Complete
REC Mode >
Mic Sensitivity >

- 5 Press ◀◀ or ▶▶ to select a setting item, and then press ►/ENT.
For details on the menu items and settings, see “Menu Settings.”
( p. 72 – 73)

- 6 Press ◀◀ or ▶▶ to select “Edit Complete,” and then press ►/ENT.



Edit Complete
REC Mode >
Mic Sensitivity >

- 7 Press ■ STOP to exit the menu mode.











Changing the Scene Select setting to the default values

- 1 In the stop or playback mode, press and hold **BACK/HOME** to display the Home menu, then select **"Settings" → "Recording Settings" → "Scene Edit,"** and then press **▶/ENT.**
- 2 Press **◀◀** or **▶▶** to select the scene you want to change the settings to the default values, and then press **▶/ENT.**
- 3 Select **"Set Default Value,"** and then press **▶/ENT.**
 "Set to Default Value?" will be displayed.

Edit
 Edit from Current Settin
 Set Default Value
- 4 Press **◀◀** or **▶▶** to select **"YES,"** and then press **▶/ENT.**
 The menu item settings of the selected scene will be set to the default values.
- 5 Press **■ STOP** to exit the menu mode.

Default settings

For details on the menu items and settings, see pages 72 and 73.

	 Shirt Pocket	 Meeting	 Voice Notes	 Interview	 My Scene
REC Mode	MP3 192kbps	MP3 192kbps	MP3 128kbps	MP3 192kbps	MP3 192kbps
Mic Sensitivity	 Medium	 High	 Low	 Medium	 Medium
LCF(Low Cut)	ON	ON	ON	ON	ON
VOR	OFF	OFF	OFF	OFF	OFF

Starting to Record Automatically in Response to Sound – the VOR Function

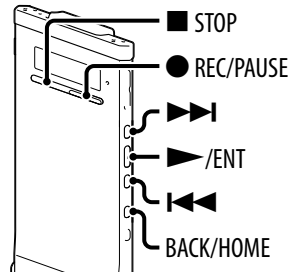

You can set the VOR (Voice Operated Recording) function to “ON,” to make the IC recorder start recording when the IC recorder detects sound that exceeds a specified level, and pause when sound falls to a level lower than a specified level.

- 1 Press and hold **BACK/HOME** to display the Home menu, then select “**Settings**” → “**Recording Settings**” → “**VOR**,” and then press **/ENT**.

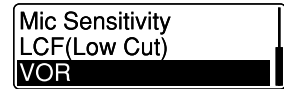

- 2 Press **left arrow** or **right arrow** to select “**ON**,” and then press **/ENT**.

- 3 Press **STOP** to exit the menu mode.

- 4 Press **REC/PAUSE**.

“**VOR**” appears in the display window.

When the IC recorder detects sound that falls below a specified level, the “**VOR**” and the counter indication flash, and the VOR recording pauses.

When the IC recorder detects sound that exceeds a specified level during the VOR recording pause, the VOR recording starts again.

To cancel the VOR function

Set “VOR” to “OFF” in step ②.

Note

The VOR function is affected by the sound around you. Set “Mic Sensitivity” in the menu according to the recording conditions. If recording is not satisfactory after you have changed the “Mic Sensitivity” setting, or for an important recording, set “VOR” to “OFF” in the menu.

Basic Playback

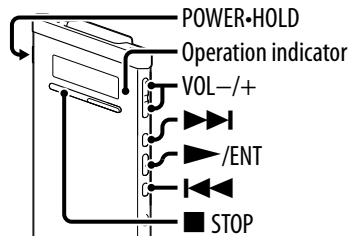

- 1 Slide the **POWER•HOLD** switch in the direction of “POWER” to turn on the IC recorder (☞ p. 20), or towards the center to release the IC recorder from the HOLD status (☞ p. 16).

The stop mode window appears.

- 2 Select the desired file to be played back (☞ p. 28).

If you do not select a file, the file just recorded will be played back.

- 3 Press **▶/ENT**.

Playback starts, and the operation indicator will light in green.

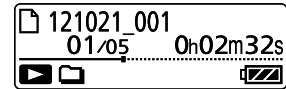

- 4 Press **VOL -/+** to adjust the volume.

Stopping playback

- 1 Press **■ STOP**.

Other operations

To	Do this
stop at the current position (Playback Pause function)	Press ►/ENT. To resume playback from that point, press ►/ENT again.
go back to the beginning of the current file	Press ◀◀ once.* ¹ * ²
go back to previous files	Press ◀◀ repeatedly. (During the stop mode, keep the button pressed to go back the files continuously.* ³)
skip to the next file	Press ▶▶ once.* ¹ * ²
skip to the succeeding files	Press ▶▶ repeatedly. (During the stop mode, keep the button pressed to skip the files continuously.* ³)

*¹ When a track mark is set, the IC recorder goes backward or forward to the track mark before or after the current point (☞ p. 60).

*² These operations are for when “Easy Search” is set to “OFF” (☞ p. 51, 75).

*³ In the continuous searching mode, the IC recorder does not locate track marks.

Changing the Playback Settings

Reducing noise or selecting the sound effect in playback – the Effect function

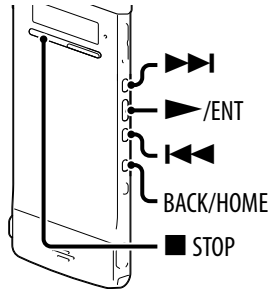

You can reduce noise in playback or select the sound effect that suits the file to be played back.

- 1 Press and hold **BACK/HOME** to display the Home menu, then select “**Settings**” → “**Playback Settings**,” and then press **/ENT**.



- 2 Press **◀◀** or **▶▶** to select “**Effect**,” and then press **/ENT**.

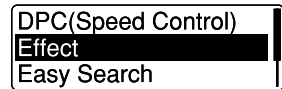

- 3 Press **◀◀** or **▶▶** to select effect you want for the playback, and then press **/ENT**.

In the stop mode, the selected file is played back automatically to reproduce the selected effect for your confirmation.

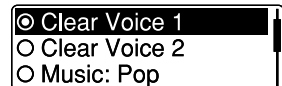

- 4 Press **■ STOP** to exit the menu mode.

Option items	Description
OFF	Disables the effect function.
Clear Voice 1	Reduces noise, excluding that of the human voice, and adjusts low and loud voices to the optimum volume automatically, making sound clear and easy-to-listen-to.
Clear Voice 2	Makes sound quality clearer, with stronger noise reduction and automatic volume adjustment functions than those of “Clear Voice 1.”
Music: Pop	Stresses middle ranges, ideal for vocals.
Music: Rock	Emphasizes high and low ranges for a powerful sound.
Music: Jazz	Emphasizes high ranges for a lively sound.
Music: Bass 1	Emphasizes the bass sound.
Music: Bass 2	Emphasizes the bass sound even more.

**Tip**

The effects of “Clear Voice 1” and “Clear Voice 2” are optimized for playback of voices, including those in conversation, and not suitable for music playback.

Adjusting the playback speed – the DPC (Digital Pitch Control) function

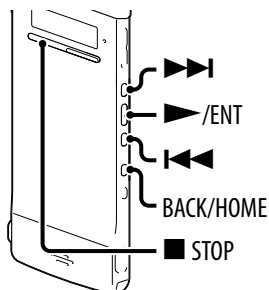

You can adjust the playback speed in a range from 0.50 times to 2.00 times normal. The file is played back in natural tones by means of a digital processing function.

- 1 Press and hold **BACK/HOME** to display the Home menu, then select **Settings** → **Playback Settings**, → **DPC(Speed Control)**, and then press **/ENT**.

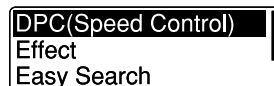

- 2 To play back at the currently set speed, press **Left Arrow** or **Right Arrow** to select **ON**, and then press **/ENT**. Skip to step 4.



To change the playback speed, press **Left Arrow** or **Right Arrow** to select **Set Speed**, and then press **/ENT**.

- 3 Press **Left Arrow** or **Right Arrow** to adjust the playback speed.



The speed decreases by 0.05 times (from $\times 0.50$ to $\times 1.00$).

The speed increases by 0.10 times (from $\times 1.00$ to $\times 2.00$).

When you press and hold each button, you can change the speed continuously.

In the stop mode, the selected file is played back automatically at the specified playback speed for your confirmation.

- 4 Press **STOP** to exit the menu mode.

To resume normal playback speed

Select **OFF** in step 2.

Note

You cannot play back an LPCM file at a speed exceeding 1.00 times the recorded speed. If you attempt to adjust the playback speed faster than that limit, "NO FAST" appears in the display window.

Selecting the play mode

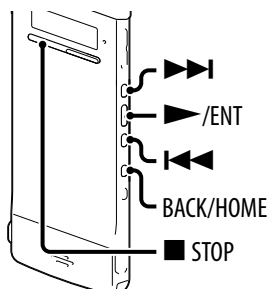

You can select the play mode in the menu.

- 1 Press and hold **BACK/HOME** to display the Home menu, then select **"Settings"** → **"Playback Settings,"** → **"Play Mode,"** and then press **▶/ENT**.

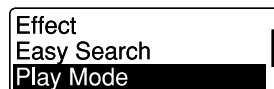

- 2 Press **◀◀** or **▶▶** to select **"1," "□," "ALL," "↶ 1," "↶ □,"** or **"↶ ALL,"** and then press **▶/ENT**.
- 3 Press **■ STOP** to exit the menu mode.

Option items	Description/reference page
1	A file is played back.
□	Files in one folder are played back continuously.
ALL	All the files are played back continuously.
↶ 1	One file is played back repeatedly.
↶ □	Files in one folder are played back repeatedly.
↶ ALL	All the files are played back repeatedly.

To play back the current file repeatedly



During playback, press and hold **▶/ENT**.

"↶ 1" appears and the current file is played back repeatedly. To resume normal playback, press **▶/ENT** again.

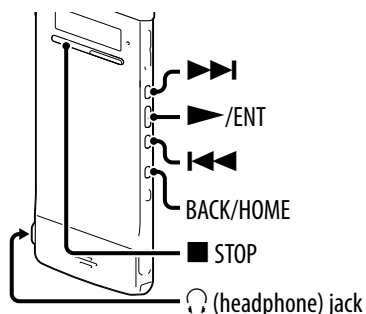

Convenient Playback Methods



Listening with better sound quality

- To listen with the headphones:
Connect the supplied stereo headphones to the  (headphone) jack. The built-in speaker will be automatically disconnected.
- To listen from an external speaker:
Connect an active speaker to the  (headphone) jack.

Searching forward/backward during playback (Cue/Review)

- To search forward (Cue):
Press and hold  during playback and release it at the point you wish to resume playback.
- To search backward (Review):
Press and hold  during playback and release it at the point you wish to resume playback.

The IC recorder searches at slow speed with playback sound. This is useful to check one word forward or back. Then, if you press and hold the button, the IC recorder starts to search at higher speed.

When files are played back or searched to the end of the last file

- When you play back or fast play back to the end of the last file, "FILE END" lights up for approx. 5 seconds.
- When "FILE END" and the operation indicator go off, the IC recorder will stop at the beginning of the last file.
- If you press and hold  while "FILE END" is lit, the files are played back rapidly, and normal playback will start at the point you release the button.

Locating the point you wish to start playback quickly – the Easy Search function

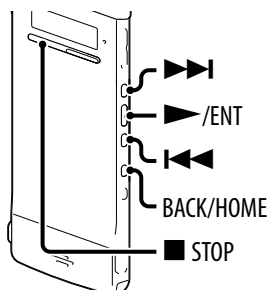

When “Easy Search” is set to “ON” in the menu, you can go back for the specified reverse skip time by pressing **⏮** once, and can go forward for the specified forward skip time by pressing **⏭** once during playback. This function is useful for locating a specific point in a long recording such as one made at a meeting.

- 1 Press and hold BACK/HOME to display the Home menu, then select “Settings” → “Playback Settings,” → “Easy Search,” and then press **▶**/ENT.**

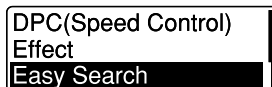

- 2 To go forward or backward for the specified skip time, press **⏮** or **⏭** to select “ON,” and then press **▶**/ENT. Skip to step 5.**



To change the time to go forward or backward when searching, press **⏮** or **⏭** to select “Set Skip Time,” and then press **▶**/ENT.

- 3 Press **⏮** or **⏭** to select “Set Forward Skip” or “Set Reverse Skip,” and then press **▶**/ENT.**



- 4 Press **⏮** or **⏭** to select the skip time, and then press **▶**/ENT.**

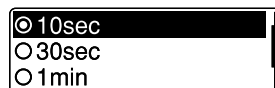

Hint

To adjust both the forward and backward skip times, repeat steps 1 through 4.

Forward Skip	5sec, 10sec, 30sec, 1min, 5min, or 10min
Reverse Skip	1sec, 3sec, 5sec, 10sec, 30sec, 1min, 5min, or 10min

- 5 Press **■** STOP to exit the menu mode.**

Playing Back a File at a Desired Time with an Alarm

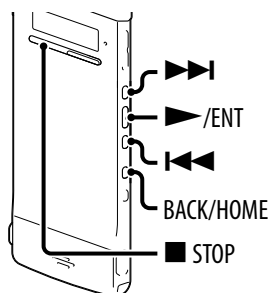

You can sound an alarm and start playback of a selected file at a desired time. You can have a file played back on a specified date, once every week, or at the same time every day. You can set an alarm for a file.

1 Select the file you want to play back with an alarm.

2 Enter the alarm setting mode.

- ① In the stop mode, press and hold **BACK/HOME** to display the Home menu, then select “**Settings**” → “**Playback Settings**,” → “**Alarm**,” and then press **▶/ENT**.

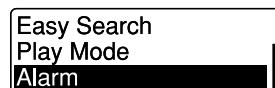

- ② Press **◀◀** or **▶▶** to select “**ON**,” and then press **▶/ENT**.

3 Set the alarm date and time.

- ① Press **◀◀** or **▶▶** to select “**Date**,” a day of the week, or “**Daily**,” and then press **▶/ENT**.



- ② **When you select “Date”:**

Set the year, month, day, hour, and minute in sequence, as described in “Setting the Clock” (🔗 p. 22).

When you select a day of the week or “Daily”:

Press **◀◀** or **▶▶** to set the hour, and then press **▶/ENT**. Press **◀◀** or **▶▶** to set the minute, and then press **▶/ENT**.

You can move the cursor back to an item by pressing **BACK/HOME**.

- 4 Press **◀◀** or **▶▶** to select a favorite alarm pattern, and then press **▶**/ENT.**

The “Please Wait” animation appears and the alarm setting becomes effective.



- 5 Press **■** STOP to exit the menu mode.**

To change the alarm setting

Select the file you want to change its alarm setting, and then follow steps **2** through **5**.

To cancel the alarm setting

Follow steps **1** and **2**. In step **2**-**2** select “OFF” and press **▶**/ENT. The alarm will be canceled and the alarm indicator will disappear from the file information window.

When the set date and time comes

At the set time, the IC recorder is automatically turned on and “ALARM” is displayed in the display window. Then the alarm and the selected file will be played back using the selected alarm pattern.

When the playback ends, the IC recorder will stop automatically. (When the alarm pattern is set to “Beep&Play” or “Play,” the IC recorder will stop at the beginning of the selected file.)

To stop the alarm playback

Press any button other than VOL -/+ while the alarm sound is heard. If the HOLD function is activated, you can stop the alarm playback by pressing any button.

To confirm the alarm setting

In the stop mode, press **■** STOP twice to display the file information window. When the “(●)” (alarm indicator) appears, the alarm has been set.

Erasing a File

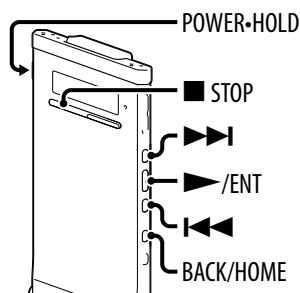

Note

Once a file has been erased, you cannot retrieve it.

- 1 Slide the **POWER•HOLD** switch in the direction of “**POWER**” to turn on the IC recorder (☞ p. 20), or towards the center to release the IC recorder from the **HOLD** status (☞ p. 16).

The stop mode window appears.

- 2 In the stop or playback mode, select the file you want to erase (☞ p. 28).

- 3 Press and hold **BACK/HOME** until the Home menu appears.

- 4 Press **◀◀** or **▶▶** to select “**🗑 Erase Files,**” and then press **▶/ENT**.



- 5 Press **◀◀** or **▶▶** to select “**Erase a File,**” and then press **▶/ENT**.

“Erase the File?” is displayed and the specified file is played back for confirmation.



- 6 Press **◀◀** or **▶▶** to select “**YES,**” and then press **▶/ENT**.

The “Please Wait” animation appears and the selected file will be erased.

When a file is erased, the remaining files will advance so that there will be no space between files.

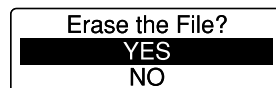

- 7 Press **■ STOP** to exit the menu mode.

To cancel erasing

Select “NO” in step ⑥, and then press ►/ENT.

To erase a part of a file

Divide the file into two files first (☞ p. 63), and then proceed with steps ③ through ⑦.

Erasing All Files in a Folder

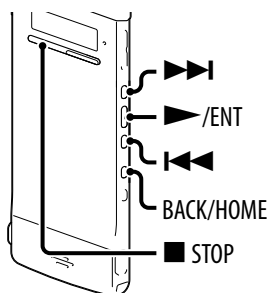

- 1 In the stop mode, select the folder containing the files you want to erase (☞ p. 28).
- 2 Press and hold BACK/HOME to display the Home menu, then select "🗑 Erase Files" ➔ "Erase All Files," and then press ►/ENT. "Erase All Files?" will be displayed.

Erase a File
 Erase All Files
- 3 Press ◀◀ or ▶▶ to select "YES," and then press ►/ENT. The "Please Wait" animation appears and all files in the selected folder will be erased.

Erase All Files?
 YES
 NO
- 4 Press ■ STOP to exit the menu mode.

To cancel erasing

Select "NO" in step 3, and then press ►/ENT.



Tip If a folder contains a file with protection setting, you cannot erase the file.

Arranging Files in a Folder

Moving a file to a different folder

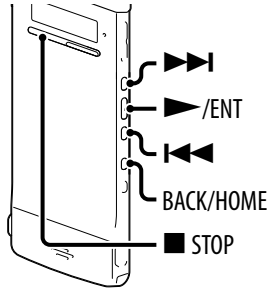



- 1 Select the file you want to move.
- 2 Press and hold BACK/HOME until the Home menu appears.
- 3 Press **◀◀** or **▶▶** to select “**Edit**,” and then press **▶**/ENT.

 Edit
- 4 Press **◀◀** or **▶▶** to select “**Edit Files**,” and then press **▶**/ENT.

Edit Files
Change Names
- 5 Press **◀◀** or **▶▶** to select “**Move File**,” and then press **▶**/ENT.

Divide at Current Positio
Divide All Track Marks
Move File
- 6 Press **◀◀** or **▶▶** to select the category of the destination folder, and then press **▶**/ENT.

 **Recording Files**
 Music

Note

When you select the “ Music” category as the destination, you can move a file to a folder containing the type of files the IC recorder can play.

- 7** Press **◀◀** or **▶▶** to select the folder that you want to move the file into, and then press **▶/ENT**.



The “Please Wait” animation appears and the file is moved to the last position in the destination folder.

When you move a file to another folder, the original file in the previous folder will be erased.

- 8** Press **■ STOP** to exit the menu mode.

To cancel moving the file

Press **■ STOP** before step **7**.

Copying a file to the other memory

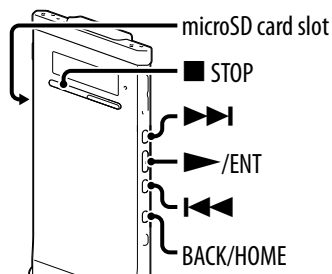

You can copy files between the built-in memory and a microSD card, which is useful in saving a backup. Before starting the operation, insert a microSD card to be used for copying into the microSD card slot.

- 1** Select the file you want to copy.

When you want to copy a file from a microSD card to the built-in memory, set the source memory media to “microSD Card” (🔍 p. 34).

- 2** Press and hold **BACK/HOME** to display the Home menu, then select **✎ Edit** → **Edit Files** → **File Copy**, and then press **▶/ENT**.



“Copy to microSD card Select Folder” or “Copy to Built-In Memory Select Folder” appears and the category selection window is displayed.

-
- 3 Press **◀◀** or **▶▶** to select the category of the destination folder, and then press **▶**/ENT.**

The folder list of the selected category is displayed.

Note

When you select the “🎵 Music” category as the destination, you can copy a file to a folder containing the type of files the IC recorder can play.

-
- 4 Press **◀◀** or **▶▶** to select the folder that you want to copy the file into, and then press **▶**/ENT.**

The “Please Wait” animation appears and the file is copied as the last file in the destination folder. A file will be copied with the identical file name.

-
- 5 Press **■** STOP to exit the menu mode.**
-

To cancel the copy operation

Press **■** STOP before step **4**.

To cancel the copy operation during copying

While the “Please Wait” animation is displayed during copying in step **4**, press **■** STOP.

Using a Track Mark

Adding a track mark

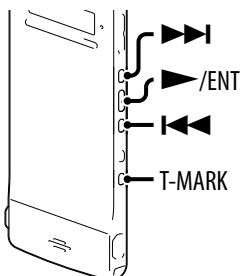



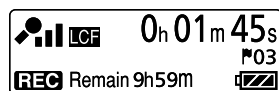

You can add a track mark at a point at which you would like to divide a file later or locate during playback. You can add a maximum of 98 track marks to each file.

During recording, playing back, or recording pausing, press T-MARK at the position you want to add a track mark.



The  (Track mark) indicator and a track number flash three times, and a track mark is added.

Locating a track mark and starting playback at the track mark

Press  or  in the stop mode. When the  (Track mark) indicator flashes once, press /ENT.

Erasing a track mark

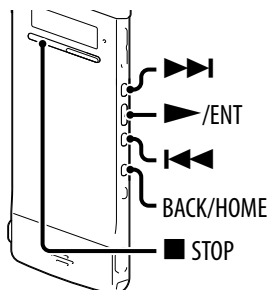

- 1 Stop at a position after the track mark you would like to erase.

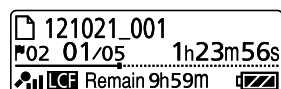

- 2 Press and hold BACK/HOME to display the Home menu, then select "Edit" → "Edit Files" → "Erase Track Mark," and then press ►/ENT.



"Erase Track Mark?" will be displayed.

- 3 Press ◀◀ or ▶▶ to select "YES," and then press ►/ENT.

The "Please Wait" animation appears and the selected track mark will be erased.

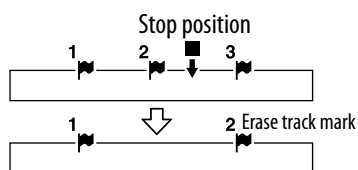

The track mark just before the stop position will be erased.

- 4 Press ■ STOP to exit the menu mode.

To cancel erasing

Select "NO" in step ③, and then press ►/ENT.

Erasing all the track marks in the selected file at one time

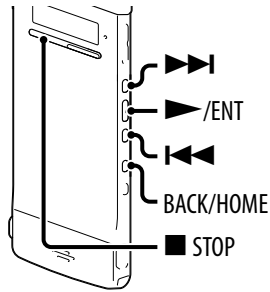

1 Select a file from which you want to erase the track marks.

2 Press and hold **BACK/HOME** to display the Home menu, then select "**Edit**" → "**Edit Files**" → "**Erase All Track Marks**," and then press **▶/ENT**.



"Erase All Track Marks?" will be displayed.

3 Press **◀◀** or **▶▶** to select "**YES**," and then press **▶/ENT**.

The "Please Wait" animation appears and all the track marks will be erased at one time.

4 Press **■ STOP** to exit the menu mode.

To cancel erasing

Select "NO" in step **3**, and then press **▶/ENT**.

Dividing a File

Dividing a file at the current position

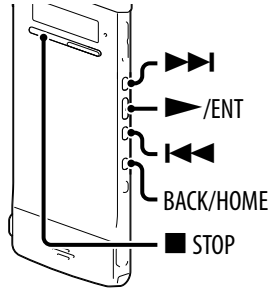

You can divide a file in the stop mode, so that the file is divided into two parts and new file numbers are added to the divided file names. By dividing a file, you can easily find the point from which you want to play back when you make a long recording such as one made at a meeting. You can divide a file until the total number of files in the folder reaches the maximum number allowed.

1 Stop the file at the position where you want to divide a file.

2 Press and hold BACK/HOME to display the Home menu, then select “ Edit” → “Edit Files” → “Divide at Current Position,” and then press /ENT.



“Divide at Current Position?” will be displayed.

3 Press or to select “YES,” and then press /ENT.

The “Please Wait” animation appears, and the file is divided. The divided files will be suffixed with a sequential number (“_1” for the original file, and “_2” for the new file).

File 1	File 2	File 3
	A file is divided.	
File 1	File 2_1	File 2_2

A suffix made up of a sequential number is added to a file name of the divided files.

4 Press STOP to exit the menu mode.

To cancel dividing

Select “NO” in step **3**, and then press /ENT.

Dividing a file at all the track mark positions

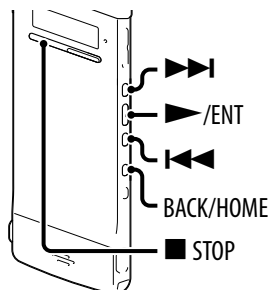

- 1 Select the file you want to divide.
- 2 In the stop mode, press and hold BACK/HOME to display the Home menu, then select “ Edit” → “Edit Files” → “Divide All Track Marks,” and then press /ENT. “Divide All Track Marks?” will be displayed.

Protect
Divide at Current Position
Divide All Track Marks

- 3 Press or to select “YES,” and then press /ENT.

The “Please Wait” animation appears, and the file is divided at all the track mark positions. All the existing track marks in the files will be erased. A suffix made up of a sequential number is added each of the divided files.

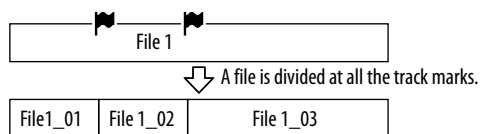

- 4 Press STOP to exit the menu mode.

To cancel dividing

Select “NO” in step 3, and then press /ENT.

To cancel the division operation during dividing

While the “Please Wait” animation is displayed during division in step 3, press STOP.

Renaming a Folder and a File

Changing a folder name

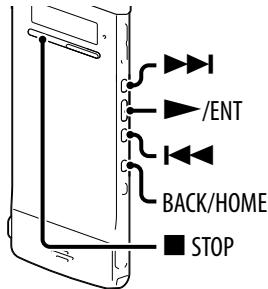

You can change a name of a folder used to store files recorded with the IC recorder.

You can choose a new folder name from the templates.

1 Select the folder which you want to rename from the folder list in the “Recording Files” category.

2 In the stop mode, press and hold BACK/HOME to display the Home menu, then select “Edit” → “Change Names,” and then press ►/ENT.

Edit Files
Change Names

3 Press ◀◀ or ▶▶ to select “Change Folder Name,” and then press ►/ENT.

Change Folder Name
Change File Name

4 Press ◀◀ or ▶▶ to select a favorite folder name, and then press ►/ENT.

The “Please Wait” animation appears and the folder name will be changed.

Conference
Meeting
Lecture

5 Press ■ STOP to exit the menu mode.

Hints

- When you specify a folder name that already exists, a suffix made up of a sequential number (2 to 10) is added to the name of the new folder.
- When you choose “FOLDER” from the templates, a suffix made up of a sequential number (01 to 10) is added to each of the folder names.
- You can use the supplied Sound Organizer software to edit the templates or rename a folder directly.

Changing a file name

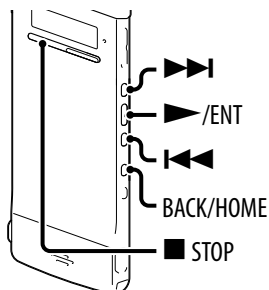

You can rename a file by prefixing characters from a desired template to the file name. A file in the recordable area can be renamed. You can choose characters to be added from the templates.

- 1 Select the file which you want to rename from the folder list in the “Recording Files” category.

- 2 In the stop mode, press and hold BACK/HOME to display the Home menu, then select “Edit” → “Change Names” → “Change File Name,” and then press ►/ENT.

Change Folder Name
Change File Name

- 3 Press ◀◀ or ▶▶ to select the desired characters to be prefixed to the file name, and then press ►/ENT.

Important
Take
Keep

The “Please Wait” animation appears and the selected characters are added to the file name separated from it by an underbar (_).

(e.g., If “A” is added to the file 11215_001, it becomes A_11215_001)

- 4 Press ■ STOP to exit the menu mode.

Hint



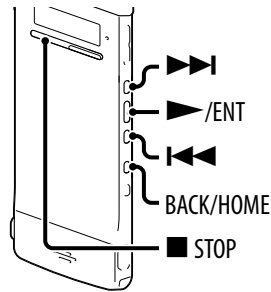

You can use the supplied Sound Organizer software to edit the templates or rename a file directly.

Protecting a File



To prevent a file from being accidentally erased or edited, you can protect an important file. When a file is protected, the  (protect) indicator is displayed in the file information window, showing that the file is regarded as a read-only file you cannot erase or edit.





- 1 **Display the file which you want to protect from a folder in the "☰ Recording Files" or "🎵 Music" category.**
- 2 **In the stop mode, press and hold BACK/HOME to display the Home menu, then select "🔧 Edit" → "Edit Files" → "Protect," and then press /ENT.**

Protect
 Divide at Current Positic
 Divide All Track Marks
- 3 **Press  or  to select "ON," and then press /ENT.**
The file is protected.
- 4 **Press  STOP to exit the menu mode.**

To release protection









Select "OFF" in step 3, and then press /ENT.

Menu Operation Modes





Home menus	Sub menus	Menu items	Operation mode (○ : the setting can be made/ — : the setting cannot be made)		
			Stop mode	Playback mode	Recording mode
 Scene Select			○	○	—
 Select File			○	○	—
 Erase Files		Erase a File	○	○	—
		Erase All Files	○	—	—
 Edit	Edit Files	Protect	○	—	—
		Divide at Current Position	○	—	—
		Divide All Track Marks	○	—	—
		Move File	○	—	—
		File Copy	○	—	—
		Erase Track Mark	○	—	—
	Change Names	Change Folder Name	○	—	—
		Change File Name	○	—	—
 Settings	Recording Settings	Scene Edit	○	○	—
		Save Destination	○	—	—
		REC Mode	○	○	—
		Mic Sensitivity	○	○	○
		LCF(Low Cut)	○	○	○
		VOR	○	○	○
	Playback Settings	DPC(Speed Control)	○	○	○
		Effect	○	○	○
		Easy Search	○	○	○
		Play Mode	○	○	○
		Alarm	○	—	—
	Select Memory		○	—	—



Home menus	Sub menus	Menu items	Operation mode (○ : the setting can be made/ — : the setting cannot be made)		
			Stop mode	Playback mode	Recording mode
 Settings	Common Settings	LED	○	○	○
		Power Saving Mode	○	○	○
		Language	○	—	—
		Date&Time	○	—	—
		Time Display	○	○	○
		Beep	○	○	○
		Format	○	—	—
		System Information	○	—	—

Menu Settings

Sub menus	Menu items	Settings (* : Initial setting)	See page
SCN Scene Select			
Allows you to choose a recording scene according to each recording situation as follows:  (Shirt Pocket)*,  (Meeting),  (Voice Notes),  (Interview),  (My Scene). You can change the items for recording to the recommended settings in bulk.			39
 Select File			
Displays category list, folder list, and then file list, allowing you to choose a file.			28
 Erase Files			
Erase a File	Erases a file. Before attempting to erase a file, select the file to be erased, and then go to the menu window. YES: The file will be erased. NO: The file will not be erased.		54
Erase All Files	Erases all the files in a folder. Before attempting to erase files, select the folder from which all files are to be erased, and then go to the menu window. YES: All the files in a folder will be erased. NO: All the files in a folder will not be erased.		56
 Edit			
Edit Files	Protect	Protects a file to prevent the file from being erased, divided, or being moved. ON: The file will be protected. OFF*: File protection is not executed. The file can be erased, edited, or moved.	67
	Divide at Current Position	Divides a file into two. YES: The file will be divided into two. NO: File division is not executed.	63
	Divide All Track Marks	Divides a file at all the track mark positions. YES: The file will be divided at all the track mark positions. NO: Division at all track marks is not executed.	64
	Move File	Moves the selected file to the selected folder. Before attempting to move a file, select the file to be moved, and then go to the menu window.	57

Sub menus	Menu items	Settings (* : Initial setting)	See page
Edit Files	File Copy	Copies the selected file from the built-in memory to the desired folder on a microSD card, or from a microSD card to the desired folder on the built-in memory. Before attempting to copy a file, select the file to be copied and then go to the menu window.	58
	Erase Track Mark	Erases the track mark just before the current position. YES: The track mark will be erased. NO: The track mark will not be erased.	61
	Erase All Track Marks	Erases all the track marks of the selected file. YES: All the track marks will be erased. NO: All the track marks will not be erased.	62
Change Names	Change Folder Name	Renames a folder by selecting a template.	65
	Change File Name	Renames a file by selecting a template and prefixing the characters of the selected template to the file name.	66

Sub menus	Menu items	Settings (* : Initial setting)	See page
 Settings			
Recording Settings	Scene Edit	<p>Edits the settings of the various recording menu items which have been pre-set in the “Scene Select” menu.</p> <p>Edit: Changes the settings from the settings in the selected scene item. When you select “Edit Complete,” the settings become effective.</p> <p>Edit from Current Setting: Changes the settings that have been pre-set in the menu. When you select “Edit Complete,” the settings become effective.</p> <p>Set Default Value: Changes the settings to the default settings.</p> <p>Execute: Changes the settings to the default settings and completes the process.</p> <p>Cancel: Completes the process without changing the settings.</p> <p> Hint You can edit the following menu items: “REC Mode”, “Mic Sensitivity” ( p. 73), “LCF(Low Cut)” ( p. 73), “VOR” ( p. 43)</p>	41
	Save Destination	Sets the destination folder in which files are recorded. You can specify a folder in the “Recording Files” category each for the built-in memory and the microSD card.	38
	REC Mode	<p>Sets the recording mode.</p> <p>LPCM 44.1kHz/16bit: LPCM (not compressed) in stereo high-quality recording mode</p> <p>MP3 192kbps*: MP3 (compressed) in stereo standard-quality recording mode</p> <p>MP3 128kbps: MP3 (compressed) in long play stereo recording mode</p> <p>MP3 48kbps(MONO): MP3 (compressed) in monaural standard recording mode</p>	—

Sub menus	Menu items	Settings (* : Initial setting)	See page
Recording Settings	Mic Sensitivity	<p>Sets the microphone sensitivity.</p> <p>High :</p> <p>To record a sound far away from the IC recorder or a low sound, such as recording in a spacious room.</p> <p>Medium *:</p> <p>To record the sound of a normal conversation or meeting, such as recording in a meeting space or during interview.</p> <p>Low :</p> <p>To record dictation with a microphone in front of your mouth, a sound near the IC recorder, or a loud sound.</p>	—
	LCF(Low Cut)	<p>Sets the LCF (Low Cut Filter) function to cut a low frequency to reduce the noise from a projector, or the roaring noise from wind; therefore you can record a file more clearly.</p> <p>ON*: The LCF function is activated.</p> <p>OFF: The LCF function is canceled.</p>	—
	VOR	<p>Sets the VOR (Voice Operated Recording) function.</p> <p>ON: Recording starts when the IC recorder detects sound that exceeds a specified level and pauses when the detected sound falls below a specified level. The VOR function is activated when ● REC/PAUSE is pressed.</p> <p>OFF*: The VOR function does not work.</p>	43
Playback Settings	DPC(Speed Control)	<p>Sets the DPC (Digital Pitch Control) function. You can adjust the playback speed in a range from 0.50 times to 2.00 times normal. The file is played back in natural tones by means of a digital processing function.</p> <p>ON(x n.nn):</p> <p>A file is played back at the specified speed (x n.nn: n=0 to 9) using the DPC function.</p> <p>OFF*:</p> <p>The DPC function does not work.</p> <p>Set Speed:</p> <p>Specify the playback speed from x0.5 to x2.00. (x0.70*)</p>	48

Sub menus	Menu items	Settings (* : Initial setting)	See page
Playback Settings	Effect	<p>Sets the effect suitable for playback sound.</p> <p>OFF*: The effect function does not work.</p> <p>Clear Voice 1: Reduces noise, excluding that of the human voice, and adjusts low and loud voices to the optimum volume automatically, making sound clear and easy-to-listen-to.</p> <p>Clear Voice 2: Makes sound quality clearer, with stronger noise reduction and automatic volume adjustment functions than those of “Clear Voice 1.”</p> <p>Music: Pop: Stresses middle ranges, ideal for vocals.</p> <p>Music: Rock: Emphasizes high and low ranges for a powerful sound.</p> <p>Music: Jazz: Emphasizes high ranges for a lively sound.</p> <p>Music: Bass 1: Emphasizes the bass sound.</p> <p>Music: Bass 2: Emphasizes the bass sound even more.</p> <p>Note When playing back a file using the built-in speaker, the effect function does not work.</p>	46

Sub menus	Menu items	Settings (* : Initial setting)	See page
Playback Settings	Easy Search	<p>Sets the easy search function.</p> <p>ON: You can go forward or backwards for the specified skip time by pressing ►► or ◀◀ during playback. This function is useful when attempting to locate a specific point in a long recording.</p> <p>OFF*: The easy search function does not work. When you press ►► or ◀◀, a file will be moved forward or backward.</p> <p>Set Skip Time: Sets the time to go forward or backward when searching.</p> <p>Set Forward Skip: Sets the time to skip forward when you press ►►. (5sec, 10sec*, 30sec, 1min, 5min, or 10min)</p> <p>Set Reverse Skip: Sets the time to skip backwards when you press ◀◀. (1sec, 3sec*, 5sec, 10sec, 30sec, 1min, 5min, or 10min)</p>	51
	Play Mode	<p>Sets the play mode.</p> <p>1: A file is played back.</p> <p>📁*: Files in one folder are played back continuously.</p> <p>ALL: All the files are played back continuously.</p> <p>↺ 1: One file is played back repeatedly.</p> <p>↺ 📁: Files in one folder are played back repeatedly.</p> <p>↺ ALL: All the files are played back repeatedly.</p>	49
	Alarm	<p>Sets the alarm function.</p> <p>ON: The alarm function is effective.</p> <p>OFF*: The alarm function is disabled.</p> <p>When you set the alarm to "ON," set the date, time or day of the week or choose daily for playback, and set the following alarm pattern.</p> <p>Beep&Play: The selected file is played back after the alarm sounds.</p> <p>Beep: Only the alarm sounds.</p> <p>Play: Only the selected file is played back.</p>	52

Sub menus	Menu items	Settings (* : Initial setting)	See page
Select Memory	<p>Selects the memory medium on which you want to store a file, or which contains the file you want to play, edit, or copy.</p> <p>Built-In Memory*: The built-in memory of the IC recorder is selected.</p> <p>microSD Card: The microSD card inserted in the microSD card slot is selected.</p> <p>Note</p> <p>When no microSD card is currently inserted in the IC recorder, the built-in memory is selected automatically.</p>		34
Common Settings	LED	<p>Turns the recording indicator and operation indicator on or off during operation.</p> <p>ON*: During recording, the recording indicator and operation indicator light or flash. During playback, the operation indicator lights or flashes.</p> <p>OFF: The recording indicator and operation indicator do not light or flash, even during recording or playback operation.</p> <p>Note</p> <p>When the IC recorder is connected to a computer, the recording indicator and operation indicator light or flash even if “LED” is set to “OFF”</p>	—
	Power Saving Mode	<p>Sets the power saving mode to limit battery consumption.</p> <p>ON*: The power saving mode is effective. If no operation is attempted for approximately 5 seconds in the stop mode and for approximately 10 seconds in the recording and playback modes, the display turns off automatically.</p> <p>OFF: The power saving mode is disabled.</p>	21

Sub menus	Menu items	Settings (* : Initial setting)	See page
Common Settings	Language	<p>Sets the language to be used for messages, menus, folder names, file names, etc.</p> <p>Deutsch (German), English, Español (Spanish), Français (French), Italiano (Italian), Русский (Russian), 한국어 (Korean), 繁體中文 (Chinese), 简体中文 (Chinese), ไทย (Thai)</p> <p>Note</p> <p>Number of language options you can select and the default setting differ depending on the region where you purchased your IC recorder.</p>	25
	Date&Time	<p>Auto(Synchronizing)*:</p> <p>When the IC recorder is connected to a computer that is running the Sound Organizer, the clock will be automatically adjusted according to that computer.</p> <p>Manual:</p> <p>Sets the clock by setting year, month, day, hour, and minute in sequence.</p>	23
	Time Display	<p>Sets the clock display.</p> <p>12-Hour: 12:00AM = midnight, 12:00PM = noon</p> <p>24-Hour: 0:00 = midnight, 12:00 = noon</p> <p>Note</p> <p>The default setting differs depending on the region where you purchased your IC recorder.</p>	—
	Beep	<p>Sets whether a beep will be heard or not.</p> <p>ON*: A beep will sound to indicate that an operation has been accepted or an error has occurred.</p> <p>OFF: No beep sound will be heard.</p> <p>Note</p> <p>The alarm sounds even if you set “Beep” to “OFF” in the menu.</p>	—

Sub menus	Menu items	Settings (* : Initial setting)	See page
Common Settings	Format	<p>Formats the memory media currently selected (the built-in memory or the microSD card), erasing all the data in the memory and resetting the folder structure to its default status.</p> <p>Execute: The memory media will be formatted.</p> <p>Cancel: The memory media will not be formatted.</p> <p>Notes</p> <ul style="list-style-type: none"> • Use the IC recorder formatting function to format a microSD card you use with the IC recorder. Do not use your computer to format a microSD card. • Switch the memory media to the one to be formatted before you start the format operation (☞ p. 34). • When you format the memory media, all the data which you have stored on the media will be erased. Once the memory media has been erased, you cannot retrieve the data that was erased. • When you format the built-in memory, the operating instructions stored in the built-in memory will also be erased. To get another copy of the operating instructions, please visit the Sony support home page depending on your area (☞ p. 104). 	—
	System Information	Displays the IC recorder model name and the version number of the software.	—

Using the IC Recorder with Your Computer

When the IC recorder is connected to your computer, you can transfer data between them.

Copying files from the IC recorder to your computer to store them (👉 p. 85)

Copying music files from your computer to the IC recorder to play them back (👉 p. 86)

Using the IC recorder as USB memory (👉 p. 88)

You can store image data or text data stored on the computer in the IC recorder.

Managing and editing files using the Sound Organizer software (👉 p. 89)

The supplied Sound Organizer software allows you to transfer the files that you have recorded using the IC recorder to your computer to manage and edit them. You can also transfer music files and podcast files stored on your computer to the IC recorder.

System requirements for your computer

For details on the system requirements for your computer, see page 91, 99.

Connecting the IC recorder to your computer

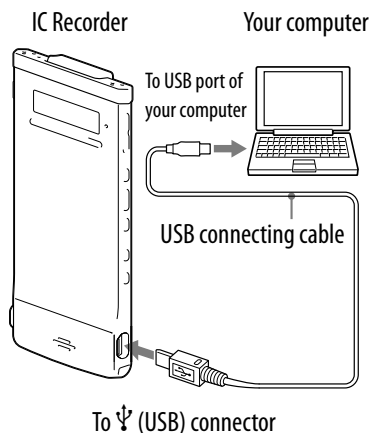

To exchange files between the IC recorder and your computer, connect the IC recorder to your computer.

- 1 Connect the Ψ (USB) connector of the IC recorder with the USB port of your running computer with the supplied USB connecting cable inserted into the connectors securely until each plug stops to the end.**
- 2 Make sure the IC recorder has been recognized properly.**

On the Windows screen; open “My Computer” or “Computer,” and make sure that “IC RECORDER” or “MEMORY CARD” has been recognized. On the Macintosh screen; make sure that an “IC RECORDER” or “MEMORY CARD” drive is displayed on the Finder side bar.

The IC recorder is recognized by the computer as soon as the connection is made. While the IC recorder is connected to the computer, “Connecting” is displayed in the display window of the IC recorder.

Structure of folders and files

The folders and files are displayed on the computer screen as shown. On a Windows screen using Explorer, and on a Macintosh screen using Finder, folders and files can be displayed by opening “IC RECORDER” or “MEMORY CARD.”

When connecting the IC recorder with your computer after the destination memory media has been set to “microSD Card” (☞ p. 34), the structure of folders is different from that when the destination memory media is set to “Built-In Memory.”

Built-in memory

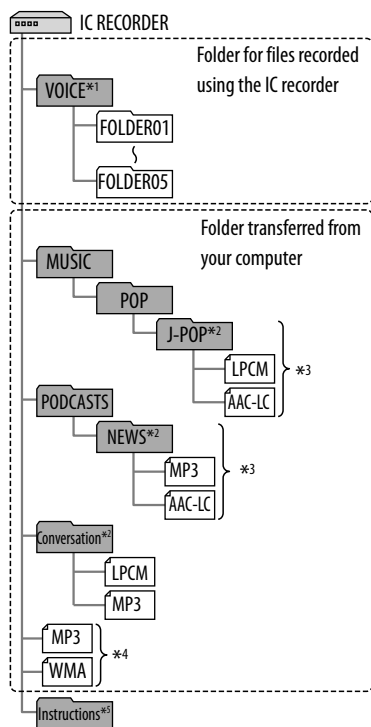

microSD card

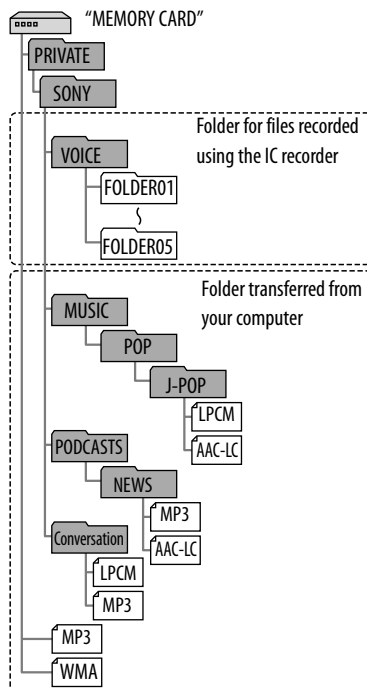

*1 Even if a file is transferred directly under the VOICE folder, it will not be displayed on the “☞ Recording Files” category of the IC recorder. When you transfer a file from your computer to the IC recorder, put the file in the folders under the VOICE folder.

*2 The name of a folder in which music or podcast files are stored will be displayed on the IC recorder as it is, so it is convenient if you put an easy-to-remember name on the folder in advance.

Folders shown in the illustration are examples of folder names.

*3 The IC recorder can recognize up to 8 levels of folders transferred to the IC recorder.

*4 If you transfer music files separately, they are classified as being in “No Folder.”

*5 The operating instructions of the IC recorder are stored in the “Instructions” folder directly under the “IC RECORDER” folder.



Hints

- The title or artist name, etc., registered in the music files, can be displayed on the IC recorder. It is useful if you input the ID3 tag information using the software you use to make the music files on your computer.
- If no title, or artist name has been registered “No Data” will be displayed in the display window of the IC recorder.

Structure of folders displayed in the display window of the IC recorder

The display of the structure of the folders seen in the display window of the IC recorder is different from that seen on the display of a computer.

The folder indicators in the display window of the IC recorder are as follows:

-  : Folder for files recorded using the IC recorder
-  : Folder transferred from a computer (They are displayed when music files have been transferred from a computer.)
-  : Folder for podcast files transferred from a computer (These folders are displayed when podcast files have been transferred from a computer.)

Note

If folders have no files that can be played back using the IC recorder, those folders will not be displayed in the display window of the IC recorder.

Folders displayed in the “ Recording Files” category of the IC recorder



Folders for files recorded using the IC recorder (folders under the VOICE folder) will be displayed.

Note

Even if a file is transferred directly under the VOICE folder, it will not be displayed in the “ Recording Files” category of the IC recorder.

Folders displayed on the “🎵 Music” category of the IC recorder

The following folders will be displayed among the folders forwarded from a computer.

- Folders under the MUSIC folder which contains a file (when some folders have multiple levels, all folders will be displayed in parallel.)
- Folders transferred to places other than under the MUSIC folder or the PODCASTS folder
- A folder called “No Folder” (If you transfer music files separately, those files will be displayed under this folder.)

Folders displayed on the “🎧 Podcast” category of the IC recorder

Folders for podcast files transferred from a computer will be displayed. When you transfer podcast files from your computer to the IC recorder, use the supplied Sound Organizer software.

Disconnecting the IC recorder from your computer

Follow the procedures below; otherwise, data may be damaged.

1 Make sure that the operation indicator of the IC recorder does not light.

2 Perform the following operation on your computer. *1

On the Windows taskbar at the bottom right of the desktop, left-click the following icon:



➔ Left-click “Eject IC RECORDER” (Windows 7), or “Safely remove USB Mass Storage Device” (Windows XP, Windows Vista).

The icon and menu displayed can be different on different operating systems. The icon may not be always displayed on the taskbar depending on your computer settings.

On a Macintosh screen, click the “IC RECORDER” or “MEMORY CARD” ejection icon on the Finder side bar.

3 Disconnect the USB connecting cable from the IC recorder and the USB port of the computer.

*1 For details on disconnecting the IC recorder from your computer, refer to the operating instructions supplied with your computer.

Copying Files from the IC Recorder to Your Computer

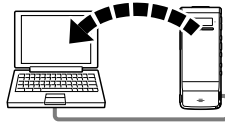

You can copy the files and folders from the IC recorder to your computer to store them.

1 Connect the IC recorder to your computer (☞ p. 80).

2 Copy files or folders you want to transfer to your computer.

Drag and drop the files or folders you want to copy from “IC RECORDER” or “MEMORY CARD” to the local disk on your computer.

💡 To copy a file or folder (Drag and drop)

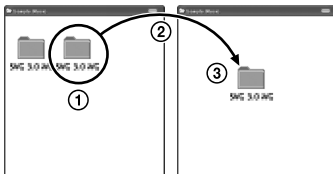

IC recorder or a
microSD card

Your computer

- ① Click and hold,
- ② drag,
- ③ and then drop.

3 Disconnect the IC recorder from your computer (☞ p. 84).

Copying Music Files from Your Computer to the IC Recorder and Playing Them Back

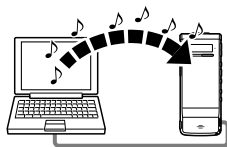

You can copy music or the other audio files (LPCM(.wav)/MP3(.mp3)/WMA(.wma)/AAC-LC(.m4a)*) from your computer to the IC recorder by dragging and dropping them, and you can play them back using the IC recorder.

* For the file formats that can be played back using the IC recorder, see “Design and specifications” (☞ p. 101).

Copying a music file from your computer to the IC recorder (drag and drop)

1 Connect the IC recorder to your computer (☞ p. 80).

2 Copy the folder in which the music files are stored to the IC recorder.

On a Windows screen using Explorer, or on a Macintosh screen using Finder, drag and drop the folder containing the music files onto “IC RECORDER” or “MEMORY CARD.”

The IC recorder can recognize up to 400 folders. You can copy up to 199 files to one folder. Moreover, the IC recorder can recognize up to a total of 4,095 folders and files for one memory media.

3 Disconnect the IC recorder from your computer (☞ p. 84).

Playing back music files copied from your computer using the IC recorder

1 Select a folder.

① Display the category list with either of the following:

- In the stop or playback mode, press and hold BACK/HOME to display the Home menu, then select “□ Select File,” and press ►/ENT.
- In the stop mode, press BACK/HOME repeatedly until the category list is displayed.

② Press ◀◀ or ▶▶ to select “🎵 Music,” and then press ►/ENT.

③ Press ◀◀ or ▶▶ to select the folder (📁) in which the desired music files are stored, and then press ►/ENT.

2 Select the music file you want to play.

Press ◀◀ or ▶▶ to select the desired file, and then press ►/ENT. Playback of the selected file starts.

3 Press ■ STOP to stop playback.

To play back another file

In stop mode, press ◀◀ or ▶▶ to display the desired file, and then press ►/ENT to start playback.

Using the IC Recorder as USB Memory

When the IC recorder is connected to your computer, image data or text data on the computer, as well as files recorded using the IC recorder can be stored on the IC recorder.

Your computer must meet the specified system requirements to use the IC recorder as USB memory.

For details on the system requirements, see page 99.

Using the Supplied Sound Organizer Software

What you can do using Sound Organizer

Sound Organizer allows you to exchange files with an IC recorder or memory card. The songs imported from music CDs and other media, MP3 and other audio files imported from a computer, and podcasts can also be played and transferred to an IC recorder. Various operations can be performed for imported files, including playback, editing and conversion to MP3 and other formats. You can also burn CDs of the music you like, and send audio files by mail.

Importing files recorded with an IC recorder

You can import recording files that were recorded with an IC recorder into Sound Organizer.

The imported files are saved to the computer.

Importing songs from a music CD

You can import the songs of a music CD into Sound Organizer.

The imported songs are saved to the computer.

Importing songs on the computer

You can import music and other files saved to the computer into Sound Organizer.

Subscribing to and updating podcasts

You can subscribe to podcasts in Sound Organizer.

Subscribing to and updating podcasts enables you to download (subscription) and enjoy the latest data from the Internet.

Playing files

You can play the files imported into Sound Organizer.

Changing the file information of files

You can change the title name, artist name, and other file information displayed in the file list.

Dividing files

You can divide one file into multiple files.

Combining files

You can combine multiple files into one file.

Editing templates for a folder or file name

You can edit the templates used as “Change File Name” and “Change Folder Name” menu options.

Deleting files from an IC recorder

You can delete a file saved to an IC recorder.

Use this operation to delete files in the IC recorder when you want to increase the amount of free space in the IC recorder or there are unnecessary files.

Transferring files to an IC recorder

You can transfer a file from Sound Organizer to an IC recorder or memory card.

You can enjoy transferred music, podcasts, and other content on your IC recorder.

Burning a music CD

You can select your favorite songs from the songs imported into Sound Organizer and then burn your own original music CD.

Other convenient uses

- You can start the mail software and send a recording file attached to mail.
- You can use the voice recognition software Dragon NaturallySpeaking (not supplied) which is compatible with Sound Organizer to perform voice recognition for a file and convert the voice to text.

System requirements for your computer

The following shows the system requirements for using Sound Organizer.

Operating systems

- Windows 7 Ultimate
- Windows 7 Professional
- Windows 7 Home Premium
- Windows 7 Home Basic
- Windows 7 Starter (32 bit version)
- Windows Vista Ultimate Service Pack 2 or higher
- Windows Vista Business Service Pack 2 or higher
- Windows Vista Home Premium Service Pack 2 or higher
- Windows Vista Home Basic Service Pack 2 or higher
- Windows XP Media Center Edition 2005 Service Pack 3 or higher
- Windows XP Media Center Edition 2004 Service Pack 3 or higher*
- Windows XP Media Center Edition Service Pack 3 or higher*
- Windows XP Professional Service Pack 3 or higher
- Windows XP Home Edition Service Pack 3 or higher

Pre-installed.

* Excluding China

Notes

- One of the above operating systems should be by default pre-installed. Upgraded operating systems or multi-boot environment are not supported.
- 64 bit versions of Windows XP are not supported.

IBM PC/AT or compatible

- CPU
 - Windows XP: Pentium III processor of 500 MHz or faster
 - Windows Vista: Pentium III processor of 800 MHz or faster
 - Windows 7: Pentium III processor of 1 GHz or faster
- Memory
 - Windows XP: At least 256 MB
 - Windows Vista: At least 512 MB (In the case of Windows Vista Ultimate/Business/Home Premium, at least 1 GB is recommended.)
 - Windows 7: At least 1 GB (32 bit version)/At least 2 GB (64 bit version)
- Free hard disk space
 - At least 400 MB is required.
 - Depending on the version of Windows, more than 400 MB may be used.
 - Also, free space for handling music data is required.
- Display settings
 - Screen resolution: 800 × 600 pixels or higher (1,024 × 768 pixels is recommended.)
 - Screen color: High Color (16 bit) or higher

Continued ↓

- Sound card
A SoundBlaster compatible card is recommended.
- USB port
A compatible USB port is required to use devices and media.
Operation via a USB hub is not guaranteed except for models for which operation has been specifically guaranteed.
- Disk drive
A CD-ROM drive is required. To create a music CD, you need a CD-R/RW drive.

Installing Sound Organizer

Install Sound Organizer on your computer.

Notes

- When installing Sound Organizer, log in to an account with administrator privileges. Also, if you are using Windows 7 and the [User Account Control] screen appears, confirm the contents of the screen and then click [Yes] ([Continue] in the case of Windows Vista).
- Sound Organizer cannot be started by a user with limited privileges in Windows XP.
- To use the software update function in Windows XP, you must log on to an account with computer administrator privileges.
- The Windows Media Format Runtime module is added by the installer of Sound Organizer. This module is not removed when Sound Organizer is uninstalled. However, it may not be installed if it has been preinstalled.
- The data in the content storage folders is not deleted when Sound Organizer is uninstalled.
- In an installation environment in which multiple operating systems are installed on one computer, do not install Sound Organizer in each of the operating systems. Doing so may result in data inconsistencies.

1 Make sure that the IC recorder is not connected, then turn on your computer and start up Windows.

2 Insert the supplied CD-ROM into the CD-ROM drive.

The [Sound Organizer - InstallShield Wizard] menu starts up automatically and the [Welcome to Sound Organizer Installer] window appears.

If the [Welcome to Sound Organizer Installer] menu does not start up, open Windows Explorer, right-click the CD-ROM drive, double-click [SoundOrganizerInstaller.exe], and then follow the instructions on the screen.

-
- 3 Make sure that you accept the terms of the license agreement, select [I accept the terms in the license agreement], then click [Next].**

 - 4 When the [Setup Type] window appears, select [Standard] or [Custom], and then click [Next].**
Follow the instructions on the screen and set the installation settings when you select [Custom].

 - 5 When the [Ready to Install the Program] window appears, click [Install].**
The installation starts.

 - 6 When [Sound Organizer has been installed successfully.] window appears, check [Launch Sound Organizer Now], and then click [Finish].**
-

Note

You may need to restart your computer after installing Sound Organizer.

The Sound Organizer window

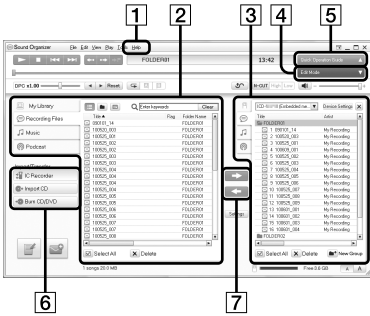

1 Help

Displays the help of Sound Organizer. For details on each operation, refer to these help files.

2 The file list of Sound Organizer (My Library)

Displays a list of files included in My Library of Sound Organizer in accordance with the operation.

☞ Recording Files: Displays a list of recording files.

Recording files that were recorded with an IC recorder appear in this library when they are imported.

🎵 Music: Displays a list of music files.

Songs imported from a music CD appear in this library.

📻 Podcast: Displays a list of podcasts.

3 The file list of the IC recorder

Displays the files saved to the connected IC recorder or memory card.

4 Edit Mode button

Displays the edit area so that you can edit a file.

5 Quick Operation Guide button

Displays the Quick Operation Guide to receive guidance on the basic features of Sound Organizer.

6 Sidebar (Import/Transfer)

📁 IC Recorder: Displays the transfer screen. A list of files on a connected device appears.

📀 Import CD: Displays the screen for importing music CDs.

🔥 Burn CD/DVD: Displays the screen for burning discs.

7 Transfer buttons

➡: Transfers the files of Sound Organizer to an IC recorder or memory card.

⬅: Imports the files of an IC recorder or memory card to My Library of Sound Organizer.

Using a USB AC Adaptor

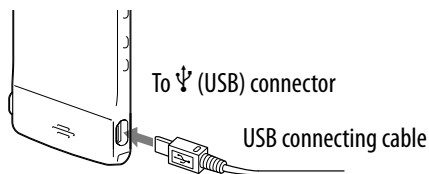

You can charge the built-in rechargeable battery by connecting the IC recorder to an AC outlet using a USB AC adaptor (not supplied). You can charge the battery while you are using the IC recorder, so that it is useful when you want to record for a long time.

When you use the IC recorder for the first time, or after you have not used the IC recorder for a certain period of time, charge the battery continuously until “**FULL**” is displayed.

It takes about 1 hour 30 minutes to fully charge an exhausted battery.*

* This is an approximation for the time it takes to charge from no remaining battery power to full battery power at room temperature. It varies depending on the remaining power and the condition of the battery.

- 1 Connect a USB AC adaptor (not supplied) to an AC outlet.**
- 2 Connect the USB AC adaptor to the supplied USB connecting cable.**
- 3 Connect the USB connecting cable to the Ψ (USB) connector of the IC recorder.**

While the battery is charging, the battery indicator is displayed in an animation.

Now you can use the IC recorder while charging the battery.

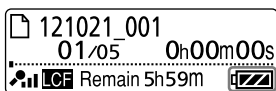

Battery indicator

Note

While playing back files using the built-in speaker, you cannot charge the battery.

Disconnecting the IC recorder from the AC outlet

Follow the procedures below; otherwise, when the IC recorder contains data files, the files may be damaged or become unplayable.

- 1 If you are recording or playing back a file, press ■ STOP to put the IC recorder into the stop mode.**
- 2 Make sure that the operation indicator of the IC recorder does not light.**
- 3 Disconnect the IC recorder from the USB AC adaptor, and then disconnect the USB AC adaptor from the AC outlet.**

Precautions

On power

Operate the unit only on 3.7 V DC with the built-in rechargeable lithium-ion battery.

On safety

Do not operate the unit while driving, cycling or operating any motorized vehicle.

On handling

- Do not leave the unit in a location near heat sources, or in a place subject to direct sunlight, excessive dust or mechanical shock.
- Should any solid object or liquid fall into the unit, have the unit checked by qualified personnel before operating it any further.
- Be careful not to allow water to splash on the unit. The unit is not waterproof. In particular, be careful in the following situations.
 - When you have the unit in your pocket and go to the bathroom, etc. When you bend down, the unit may drop into the water and may get wet.
 - When you use the unit in an environment where the unit is exposed to rain, snow, or humidity.
 - In circumstances where you get sweaty. If you touch the unit with wet hands or if you put the unit in the pocket of sweaty clothes, the unit may get wet.
- You may feel pain in your ears if you use the headphones when the ambient air is very dry. This is not because of a malfunction of the headphones, but because of static electricity accumulated in your body. You can reduce static electricity by wearing non-synthetic clothes that prevent the emergence of static electricity.

On noise

- Noise may be heard when the unit is placed near an AC power source, a fluorescent lamp or a mobile phone during recording or playback.
- Noise may be recorded when an object, such as your finger, etc., rubs or scratches the unit during recording.

On maintenance

To clean the exterior, use a soft cloth slightly moistened in water. Then use a soft dry cloth to wipe the exterior. Do not use alcohol, benzine or thinner.

If you have any questions or problems concerning your unit, please consult your nearest Sony dealer.

Backup recommendations

To avoid potential risk of data loss caused by accidental operation or malfunction of the IC recorder, we recommend that you save a backup copy of your recorded files to a computer, etc.

On using a microSD card

- When formatting (initializing) a microSD card, make sure to use the IC recorder to format it. Operations of the microSD cards formatted with Windows or other devices are not guaranteed.
- If you format a microSD card containing recorded data, the recorded data will be deleted. Be careful not to delete important data.
- Do not leave a microSD card within the reach of small children. They might accidentally swallow it.
- Do not insert or remove a microSD card during recording/playback/formatting. Doing so may cause a malfunction of the IC recorder.
- Do not remove a microSD card while the operation indicator is flashing in orange. Doing so may damage the data.
- We do not guarantee the operations of all types of compatible microSD cards with the IC recorder.
- You cannot use a ROM (read-only-memory) type or write-protected microSD card.
- Data may be corrupted in the following cases:
 - When a microSD card is removed or the IC recorder is turned off during a read or write operation.
 - When a microSD card is used in locations subject to static electricity or electrical noise.
- We assume no responsibility for any loss or damage of recorded data.
- We recommend that you save a backup copy of the important data.
- Do not touch the terminal of a microSD card with your hand or a metal object.
- Do not strike, bend or drop a microSD card.
- Do not disassemble or modify a microSD card.
- Do not expose a microSD card to water.
- Do not use a microSD card under the following conditions:
 - Locations beyond the required operating conditions, including locations, such as the hot interior of a car parked in the sun and/or in the summer, the outdoors exposed to direct sunlight, or a place near a heater.
 - Humid locations or locations with corrosive substances present.
- When using a microSD card, make sure to check the correct insertion direction into the microSD card slot.

Specifications

System requirements

To use your computer with the Sound Organizer software

To use your computer with the Sound Organizer software, see “System requirements for your computer” (🔗 p. 91).

To use your computer without the Sound Organizer software

To use your computer with the IC recorder without the Sound Organizer software, or to use the IC recorder as a USB mass storage device, your computer must meet the operating system requirements and port environment described below.

Operating systems

- Windows 7 Ultimate
- Windows 7 Professional
- Windows 7 Home Premium
- Windows 7 Home Basic
- Windows 7 Starter
- Windows Vista Ultimate Service Pack 2 or higher
- Windows Vista Business Service Pack 2 or higher
- Windows Vista Home Premium Service Pack 2 or higher
- Windows Vista Home Basic Service Pack 2 or higher
- Windows XP Media Center Edition 2005 Service Pack 3 or higher
- Windows XP Media Center Edition 2004 Service Pack 3 or higher*
- Windows XP Media Center Edition Service Pack 3 or higher*
- Windows XP Professional Service Pack 3 or higher
- Windows XP Home Edition Service Pack 3 or higher
- Mac OS X (v10.3.9-v10.7)

Pre-installed.

* Excluding China

Notes

- One of the above operating systems should be by default pre-installed. Any operating system other than those indicated above (Windows 98, Windows 2000 or Linux, etc.), upgraded operating systems or multi-boot environment are not supported.
- 64 bit versions of Windows XP are not supported.
- For the latest version information and compatibility with your operating system, please access the support home page for the IC recorder (🔗 p. 104).

Hardware environment:

- Sound board: Sound boards compatible with any of the supported operating systems
- Port: USB port
- Disk drive

A CD-ROM drive is required. To create a music CD, you need a CD-R/RW drive.

Notes

The following systems are not supported:

- Operating systems other than the ones indicated on page 99
- Personally constructed computers or operating systems
- Upgraded operating systems
- Multi-boot environment
- Multi-monitor environment

Design and specifications

IC Recorder section

Capacity (User available capacity)

4 GB (approx. 3.60 GB = 3,865,470,566 Byte)

A part of the memory capacity is used as a management area.

Maximum number of folders (for a drive)

400 folders

Maximum number of files (for a folder)

199 files

Maximum number of files (for a drive)

4,074 files (When 21 folders are contained in a drive.)

Frequency range

LPCM 44.1kHz/16bit	95 Hz - 20,000 Hz
--------------------	-------------------

MP3 192kbps	95 Hz - 18,000 Hz
-------------	-------------------

MP3 128kbps	95 Hz - 16,000 Hz
-------------	-------------------

MP3 48kbps(MONO)	95 Hz - 14,000 Hz
------------------	-------------------

Compatible file formats

MP3* ¹	Bit rate: 32 kbps - 320 kbps (Supports variable bit rate (VBR)) Sampling frequencies: 16/22.05/24/32/44.1/48 kHz File extension: .mp3 * ¹ The playback of MP3 files recorded using the IC recorder is also supported. Not all encoders are supported.
-------------------	---

WMA* ²	Bit rate: 32 kbps - 192 kbps (Supports variable bit rate (VBR)) Sampling frequencies: 44.1 kHz File extension: .wma * ² WMA Ver. 9 is compatible, however, MBR (Multi Bit Rate), Lossless, Professional, and Voice are not supported. Copyright-protected file cannot be played back. Not all encoders are supported.
-------------------	---

AAC-LC* ³	Bit rate: 16 kbps - 320 kbps (Supports variable bit rate (VBR)) Sampling frequencies: 11.025/12/16/22.05/24/32/44.1/48 kHz File extension: .m4a * ³ Copyright-protected file cannot be played back. Not all AAC encoders are supported.
----------------------	--

LPCM	Sampling frequencies: 44.1 kHz Quantization bit rate: 16 bit File extension: .wav
------	---

General section	
Speaker	
Approx. 10 mm × 6 mm (13/32 inches × 1/4 inches) dia.	
Input/Output	
Headphone jack	(minijack, stereo) Recommended load impedance: 16 ohms
USB connector	(micro B) High-Speed USB compatible
microSD card slot	microSD card/microSDHC card compatible
Playback speed control (DPC)	
2.00 times - 0.50 times	MP3/WMA/AAC-LC
1.00 time - 0.50 times	LPCM
Power output	
150 mW	
Power requirements	
Built-in rechargeable lithium-ion battery	3.7 V DC
Operating temperature	
5°C - 35°C (41 °F to 95 °F)	
Dimensions (w/h/d) (not incl. projecting parts and controls) (JEITA)*⁴	
Approx. 40.8 mm × 102.3 mm × 6.4 mm (1 5/8 inches × 4 1/8 inches × 9/32 inches)	
Mass (JEITA)*⁴	
Approx. 50 g (1 3/4 oz.)	
* ⁴ The standard of JEITA (Japan Electronics and Information Technology Industries Association)	
Supplied accessories	
See supplied Quick Start Guide	

Design and specifications are subject to change without notice.

Maximum recording time^{*5*6}

The maximum recording time of all the folders is as follows.

REC mode (Recording scene ^{*7})	Built-in memory	microSD card				
		2GB	4GB	8GB	16GB	32GB
LPCM 44.1kHz/16bit	6h.	3h.	6h.	12h. 5m.	24h. 15m.	48h. 40m.
MP3 192kbps (🎧 / 🎧 / 🎧 / 🎧)	44h. 40m.	22h. 20m.	44h. 40m.	89h. 25m.	178h.	357h.
MP3 128kbps (🎧)	67h. 5m.	33h. 30m.	67h. 5m.	134h.	268h.	536h.
MP3 48kbps(MONO)	178h.	89h. 25m.	178h.	357h.	715h.	1431h.

h.: hours/m.: minutes

^{*5} When you are going to record continuously for a long time, you may have to use a USB AC adaptor (not supplied). For details on the battery life, see the “Battery life” table.

^{*6} The maximum recording time in the above table is for your reference only, and may differ depending on the card specifications.

^{*7} Default settings

The maximum playback time of music files/number of files^{*8}

Bit rate	Playback time	Number of files
48 kbps	178h.	2670 files
128 kbps	67h. 5m.	1006 files
256 kbps	33h. 30m.	502 files

h.: hours/m.: minutes

^{*8} In the case where MP3 files of 4 minutes each are transferred to the IC recorder.

Battery life

With built-in rechargeable lithium-ion battery^{*1}

REC Mode	Recording	Playback through speaker ^{*2}	Playback using the headphones
LPCM 44.1kHz/16bit	Approx. 18h.	Approx. 10h.	Approx. 19h.
MP3 192kbps	Approx. 24h.	Approx. 11h.	Approx. 23h.
MP3 128kbps	Approx. 24h.	Approx. 11h.	Approx. 25h.
MP3 48kbps(MONO)	Approx. 24h.	Approx. 11h.	Approx. 26h.
Music file (128 kbps/44.1kHz)	—	Approx. 11h.	Approx. 26h.

h.: hours

^{*1} Measured value by the standard of JEITA (Japan Electronics and Information Technology Industries Association). The battery life may shorten depending on how you operate the IC recorder.

^{*2} When playing back music through the internal speaker with the volume level set to 28

Troubleshooting

Before taking the IC recorder for repair, check the following sections. Should any problem persist after you have made these checks, consult your nearest Sony dealer.

Please access the following support home page to get the support information about your IC recorder:

For customers in Europe:

<http://support.sony-europe.com/DNA>

For customers in Latin America:

<http://www.sony-latin.com/index.crp>

For customers in the U.S.A.:

<http://www.sony.com/recordersupport>

For customers in Canada:

<http://www.sony.ca/ElectronicsSupport>

<http://fr.sony.ca/ElectronicsSupport>

For customers in other countries/regions:

<http://www.sony-asia.com/support>

Note that recorded files may be deleted during service or repair work.

About resetting the IC recorder

When a problem persists after you check any corrective actions listed in the following troubleshooting tables, you may solve the problem by resetting the IC recorder. Press the RESET button with a small pin, etc. If you press the RESET button while operating the IC recorder, stored data and settings may be deleted. Before resetting, make sure that the operation indicator is not lit.

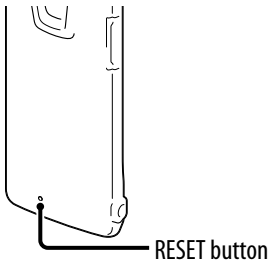

On the IC recorder operations

Noise

Noise is heard.

- An object, such as your finger, etc., accidentally rubbed or scratched the IC recorder during recording so that noise was recorded.
- The IC recorder was placed near an AC power source, a fluorescent lamp or a mobile phone during recording or playback.
- The plug of the connected headphones is dirty.
→ Clean the plug.

Power source

The IC recorder cannot be turned on. The IC recorder does not operate, even if you press any button.

- The built-in rechargeable battery is weak.
- The power of the IC recorder is off.
→ Slide and hold the POWER•HOLD switch in the direction of “POWER” until the window display appears. The power is turned on (🔍 p. 20).
- The HOLD function is activated.
→ Slide the POWER•HOLD switch in the center direction (🔍 p. 16).

The IC recorder cannot be turned off.

- When the IC recorder is in the stop mode, slide and hold the POWER•HOLD switch in the direction of “POWER” until the “Power Off” animation is displayed. The power is turned off (🔍 p. 20).

The IC recorder is powered off automatically.

- When the IC recorder is in the stop mode and you leave the IC recorder without attempting an operation for approximately 10 minutes, the auto power off function will take effect. When you slide the POWER•HOLD switch in the direction of “HOLD” in the stop mode, the IC recorder enters the standby mode. In the standby mode, the IC recorder turns off automatically if there is no operation attempted for 24 hours. Until then, the IC recorder does not turn off completely unless you turn it off manually.

The battery life is short.

- The battery life on page 103 is based on playback with the volume level set to 28. The battery life may shorten depending on the operation of the IC recorder.
 - Even if you do not use the IC recorder, the battery is consumed slightly. If you do not intend to use the IC recorder for an extended period of time, it is recommended that you turn the power off (⏻ p. 20). “Power Saving Mode” is set to “ON” in the menu by default (⏻ p. 21, 76), so that you can reduce the battery consumption.
 - The battery indicator is displayed only for a short time, however, the rechargeable battery is not charged completely. It takes about 1 hour 30 minutes to fully charge an exhausted battery.
 - You are using the IC recorder in an environment with a temperature of under 5 °C (41 °F). Battery life becomes shorter as a result of the battery characteristics. This is not a malfunction.
 - The IC recorder has not been used for more than 1 year.
 - The built-in rechargeable battery may have deteriorated. Consult with your nearest Sony dealer.
 - If the battery life is limited to approximately half the original battery life, even after you charge it fully, the battery has deteriorated.
 - Consult your nearest Sony dealer.
-

Charging

You cannot charge the battery by connecting the IC recorder to your computer.

- When you connect the IC recorder to a computer which is not running, the battery will not be charged. Even if the computer is on, and the computer is in a mode of reduced operation (standby or sleep), you cannot charge the battery.
 - Disconnect the IC recorder from your computer and reconnect it.
-

The charging indicator is not displayed or disappears in the middle of charging.

- The USB connector of the IC recorder is not connected properly.
 - When you connect the IC recorder to a USB AC adaptor (not supplied) and play back files using the built-in speaker, you cannot charge the battery.
-

“COLD” or “HOT” is flashing instead of the battery indicator.

- The environmental temperature is out of the range for charging. Charge the battery in an environment with a temperature of 5 °C - 35 °C (41 °F - 95 °F).
-

Operating

The IC recorder does not operate correctly.

- You may have formatted the memory of the IC recorder using the computer.
→ Use the IC recorder formatting function to format the memory (🔗 p. 78).

The recording indicator and the operation indicator do not light.

- “LED” is set to “OFF”
→ Display the menu and set “LED” to “ON” (🔗 p. 76).

Recording

You cannot record a file.

- The remaining memory capacity is insufficient.
- You cannot record a file when you select a folder in the playback-only area in the “🎵 Music” or “🎧 Podcast” category.
- Files are recorded in the folder specified as “Save Destination” in the menu.

Recording is interrupted.

- The VOR function is activated. When you are not using the VOR function, set “VOR” to “OFF” in the menu (🔗 p. 43).

Playback

The playback volume is low.

- The built-in speaker is mainly for monitoring, and the playback volume is low.
→ Use the supplied headphones.

No sound comes from the speaker.

- Headphones are plugged in (🔗 p. 50).

Sound comes from the speaker even when the headphones are plugged in.

- If you plug in the headphones not securely during playback, the sound may come from the speaker.
→ Unplug the headphones, and then insert them securely.

Sound effect does not change even when the “Effect” setting is changed.

- When you are using the built-in speaker, the effect function is invalid.

Playback speed is too fast or too slow.

- “DPC(Speed Control)” in the menu is set to “ON,” and the IC recorder plays a file at the specified speed.
 - Set “DPC(Speed Control)” to “OFF” to play back a file at the normal speed. Or adjust the playback speed with “Set Speed” (ⓘ p. 48).
- You cannot play back an LPCM file at a speed exceeding 1.00 times the recorded speed. If you attempt to adjust the playback speed faster than that limit, “NO FAST” appears in the display window.

Playback sound is not good when a music file is played back.

- In “Effect” in the menu, “Clear Voice 1” or “Clear Voice 2” has been selected.
 - Set “Effect” to “OFF,” or select other effect option with the “Music:” description to play back a music file.

Editing**You cannot divide a file.**

- You need a certain amount of free space in the memory to divide a file.
- You cannot divide a protected file.
- 199 files have been recorded in the selected folder (☐).
 - Erase some of the files (ⓘ p. 54) or erase all the files after you store them on the other memory media or on your computer.
- Because of the system limitations, you may not be able to divide a file at the very beginning or at the very end of the file.
- You cannot divide files other than those recorded using the IC recorder (e.g., a file transferred from a computer).

You cannot move a file.

- You cannot move a podcast file.
- You cannot move a protected file.
- You cannot move a file to a microSD card.

You cannot copy a file to another memory.

- You cannot copy a podcast file to another memory.

Clock**“--:--” is displayed.**

- You have not set the clock (ⓘ p. 22).

“----y--m--d” or “--:--” is displayed as the recorded date or time.

- The date and time of recording will not be displayed if you recorded the file when the clock was not set.

Display

The remaining time displayed in the display window is shorter than that displayed in the supplied Sound Organizer software.

- The IC recorder requires a certain amount of memory for system operation. That amount is subtracted from the remaining time, which is the reason for the difference.

Files

The “Memory Full” message is displayed and you cannot start recording.

- The memory is full.
 - Erase some of the files (🔗 p. 54) or erase all the files after you store them on the other memory media or on your computer.

The “File Full” message is displayed and you cannot operate the IC recorder.

- 199 files have been recorded in the selected folder (📁) or 4,074 files (when there are 21 folders) in total have been recorded. Therefore you cannot record another file, or move a file.
 - Erase some of the files (🔗 p. 54) or erase all the files after you store them on the other memory media or on your computer.

The microSD card is not recognized.

- Remove a microSD card and check the side of the microSD card. Then insert it with correct side and direction (🔗 p. 32).
- Switch the memory media of the IC recorder to “microSD Card” (🔗 p. 34).

Computers

Menu does not reflect the change in settings.

- If the menu setting is changed using “IC Recorder Setting” of the Sound Organizer software with the exhausted battery, the menu setting may not function.

A character in a folder or file name is displayed in unreadable characters.

- The IC recorder cannot support or display some special characters and symbols that are entered on a computer using Windows Explorer or the Macintosh Finder.

It takes a long time to copy a file.

- If the file size of a file is large, it takes a considerable time to finish copying. Wait until the copying is finished.

The IC recorder is not recognized by your computer. A folder/file cannot be transferred from your computer.

- Disconnect the IC recorder from your computer and reconnect it.
- Do not use a USB hub or USB extension cable. Use the supplied USB connecting cable to connect the IC recorder to your computer.
- Operation is not guaranteed if you use any system requirements other than those described on page 99.
- Depending on the USB port position, the IC recorder may not be recognized. If this happens, try another port.

The file transferred from your computer cannot be played back.

- The IC recorder can recognize up to 8 levels of folders transferred to the IC recorder.
- The file format may differ from those that can be played back using the IC recorder (LPCM(.wav)/MP3(.mp3)/WMA(.wma)/AAC-LC(.m4a)). Check the compatible file formats (🔗 p. 101).

The computer cannot start.

- If you reboot the computer with the IC recorder connected to the computer, the computer may freeze or may not start properly.
 - Disconnect the IC recorder from the computer and reboot the computer.

On the Sound Organizer

Refer to the help files of the Sound Organizer software, too.

The Sound Organizer software cannot be installed.

- The free disk or memory space on the computer is too small.
 - Check the hard disk and memory space.
- You are trying to install the software into the operating system that the Sound Organizer software does not support.
 - Install the software into the supported operating system (🔗 p. 91).
- In Windows XP, you have logged on using a user name belonging to a user account with limitations. Or in Windows Vista or Windows 7, you have logged on using a guest account.
 - Make sure to log on using a user name with computer administrator privileges.

The IC recorder cannot be properly connected.

- Check that the installation of the software has been successful. Also check the connection as follows:
 - When using an external USB hub, use the supplied USB connecting cable to connect the IC recorder to your computer.
 - Disconnect and then connect the IC recorder.
 - Connect the IC recorder to another USB port.
- Your computer may be in the system standby/hibernate mode.
 - Do not let your computer enter into the system standby/hibernate mode while being connected to the IC recorder.
- Save a backup copy of all of the data stored on the built-in memory or the microSD card, and then format the built-in memory or the microSD card using the formatting function in the menu (☞ p. 78).

Playback sound from the computer is low./No sound is emitted from the computer.

- No sound board is installed.
- No speaker is built-in or connected to the computer.
- The volume of the sound is turned down.
- Turn up the volume on the computer. (Refer to the instruction manual of the computer.)
- The volume of WAV files can be changed and saved using the “Increase Volume” feature of the Microsoft Sound Recorder.

Stored files cannot be played back or edited.

- You cannot play back files whose file format the Sound Organizer software does not support. Depending on the file format, you cannot use part of editorial features of the software. Refer to the help files of the Sound Organizer software.

The counter or slider moves incorrectly, or noise is heard.

- This happens when you play back files that you divided.
 - Store a file on your computer first*, and then add it to the IC recorder. (*Select the saving file format that suits the IC recorder you use.)

Operation is slow when there are many files.

- When the total number of files increases, the operation becomes slower, regardless of the length of the recording time.

Display does not work during saving, adding, or deleting files.

- It takes a longer time to copy or delete long files.
 - Wait until the copying is finished. After completing operations, the display works normally.

The software ‘hangs’ when the Sound Organizer software starts up.

- Do not disconnect the connector of the IC recorder while the computer is communicating with the IC recorder. Otherwise the computer operations become unstable or the data inside the IC recorder may be damaged.
 - There may be conflict between the software and other driver or application.
-

Messages List

Follow the instructions below if a message appears in the display.

Message	Cause/Remedy
HOLD... Slide HOLD Switch to Activate.	<ul style="list-style-type: none"> All the button operations are disabled because the IC recorder is in the HOLD status to prevent unintentional operations. Slide the POWER•HOLD switch towards the center to release the IC recorder from the HOLD status (☞ p. 16).
Low Battery Level	<ul style="list-style-type: none"> You cannot format the memory or erase all the files in a folder because of insufficient battery power. Charge the battery (☞ p. 18).
Low Battery	<ul style="list-style-type: none"> The battery is exhausted. Charge the battery (☞ p. 18).
Low Battery to Update	<ul style="list-style-type: none"> You cannot update the firmware because of insufficient battery power. Charge the battery (☞ p. 18).
microSD Card Error	<ul style="list-style-type: none"> An error occurred while a microSD card was being inserted into the microSD card slot. Remove and try inserting it again. If this message persists, use a new microSD card.
microSD Card Not Supported	<ul style="list-style-type: none"> A microSD card that the IC recorder does not support is inserted. See “About compatible microSD cards” (☞ p. 33).
Read Only microSD Card	<ul style="list-style-type: none"> A read-only microSD card is inserted. A read-only microSD card cannot be used with the IC recorder.
microSD Card Locked	<ul style="list-style-type: none"> A write-protected microSD card is inserted. Release the lock.
Memory Full	<ul style="list-style-type: none"> The remaining memory capacity of the IC recorder is insufficient. Erase some files before recording.
File Full	<ul style="list-style-type: none"> When there are already the maximum number of files in the selected folder or the total number of files stored on the IC recorder has exceeded the maximum, you cannot record a new file. Erase some files before recording.
Settings are Full	<ul style="list-style-type: none"> You cannot rename a folder, since folders with the same folder name already exist. Please select a different folder name.
Track Marks are Full	<ul style="list-style-type: none"> You cannot set a track mark, since there are already the maximum number of track marks for a file. Cancel unwanted track marks (☞ p. 61).
File Damaged	<ul style="list-style-type: none"> You cannot play back or edit files, because the data of the selected file is damaged.

Message	Cause/Remedy
Built-In Memory Needs to be Formatted	<ul style="list-style-type: none"> The IC recorder cannot be turned on using the computer via USB connection because the IC recorder is formatted with a computer and there is no copy of the control file required for operation. Format the IC recorder using the formatting function in the menu (☞ p. 78). Do not use your computer to format the IC recorder.
microSD Card Needs to be Formatted	<ul style="list-style-type: none"> The microSD card has been formatted with a computer using a format that the IC recorder does not support. Format the microSD card using the formatting function in the menu (☞ p. 78).
Process Error	<ul style="list-style-type: none"> Save a backup copy of your data and format the IC recorder using the menu (☞ p. 78). If a problem persists, consult your nearest Sony dealer.
Stop and Reinsert microSD Card	<ul style="list-style-type: none"> A microSD card was inserted during recording or playback. Remove the microSD card and insert it while the IC recorder is in the stop mode.
Set Date&Time	<ul style="list-style-type: none"> Set the clock; otherwise, you cannot set the alarm.
No File	<ul style="list-style-type: none"> The selected folder does not have any files. You cannot move a file or set the alarm, etc., because of this.
No Track Marks	<ul style="list-style-type: none"> There are no track marks when you attempt to erase a track mark or track marks, or divide a file at all the track mark positions.
No microSD Card	<ul style="list-style-type: none"> There is no microSD card inserted into the microSD card slot when you attempt to set the “Select Memory,” or “File Copy” menus.
File Protected	<ul style="list-style-type: none"> The selected file is protected or is a “Read only” file. You cannot erase it. Cancel the protection on the IC recorder or cancel “Read only” on your computer to edit the file using the IC recorder.
Already Set	<ul style="list-style-type: none"> You set the alarm to play back a file at a date and time previously set on another file. Change the alarm setting.
Past Date/Time	<ul style="list-style-type: none"> You set the alarm when the time has already passed. Check it and set the appropriate date and time (☞ p. 52).
Unknown Data	<ul style="list-style-type: none"> This data is not in a file format that is supported by the IC recorder. The IC recorder supports LPCM(.wav)/MP3 (.mp3)/WMA(.wma)/AAC-LC(.m4a) files. For details, see “Design and specifications” (☞ p. 101). You cannot play back copyright protected files.

Message	Cause/Remedy
Invalid Operation	<ul style="list-style-type: none"> You cannot divide or set a track mark in files in the folder in the playback-only area (the “♪ Music” and “🎧 Podcast” categories). When a microSD card has a bad block on it, the card cannot be written to. Prepare a new microSD card to replace the current one. The file name has reached the maximum number of characters; you cannot divide the file. Shorten the file name. The “Divide All Track Marks” function cannot be used because there is a track mark within 0.5 seconds from the dividing position. The “Divide All Track Marks” function cannot be used because there is a track mark within 0.5 seconds from the beginning of a file or the end of a file. The file length is less than 1 second; you cannot divide such a short file. The “Divide at Current Position” function cannot be used at a position within 0.5 seconds from the beginning of a file or the end of a file.
New File	<ul style="list-style-type: none"> The file being recorded has reached the maximum size limit (2 GB for an LPCM file, and 1 GB for an MP3 file). The file will be divided automatically and recording will continue as a new file.
Change Folder	<ul style="list-style-type: none"> If there are no files in the 📁 or 📁 folder, no folders are displayed in the display window. A folder containing a file will be displayed.
Cannot Divide - Exceeds Max 199 Files in Folder	<ul style="list-style-type: none"> When there are already 199 files in the selected folder or the total number of files stored on the IC recorder exceeds the maximum, you cannot divide a file. Erase some files before dividing a file.
Same File Name Exists	<ul style="list-style-type: none"> A file of the same file name already exists in the folder, so a file cannot be created or renamed.
Erased Track Marks too near Divide Point	<ul style="list-style-type: none"> When there is a track mark set within 0.5 seconds from the dividing position, the track mark is automatically erased.
No operation with microSD Card	<ul style="list-style-type: none"> You cannot set an alarm in a file stored on a microSD card. Switch the memory media of the IC recorder to “Built-In Memory” (🔊 p. 34).
Check the Volume Level*	<ul style="list-style-type: none"> The volume of the playback sound exceeds the specified level. Adjust the volume to a moderate level.
Operation Invalid While Recording	<ul style="list-style-type: none"> You cannot operate the selected menu item during recording. Stop recording and then start the menu operation.

* for the European models only

Message	Cause/Remedy
Operation Invalid While Playing	<ul style="list-style-type: none">• You cannot operate the selected menu item during playback. Stop playback and then start the menu operation.
System Error	<ul style="list-style-type: none">• A system error other than the above has occurred. Press the RESET button to restart the IC recorder. If the problem persists, consult your nearest Sony dealer.
Save Destination Changed	<ul style="list-style-type: none">• The maximum number of files already exist in the specified “Save Destination” folder, or the folder itself has been deleted. The destination folder has been changed to another available folder.

System Limitations

There are some system limitations of the IC recorder. Troubles as mentioned below are not malfunctions of the IC recorder.

Symptom	Cause/Remedy
You cannot display or play back music files in order.	<ul style="list-style-type: none"> If you have transferred music files using your computer, those files may not be transferred in order of transfer because of system limitations. If you transfer music files from your computer to the IC recorder one by one, you can display and play back the music files in transferred order.
A file is divided automatically.	<ul style="list-style-type: none"> The file being recorded has reached the maximum size limit (2 GB for an LPCM file, and 1 GB for an MP3 file). Therefore it is automatically divided.
You cannot enter lower-case characters.	<ul style="list-style-type: none"> Depending on the combination of the characters used for the folder name that was made on your computer, those characters may change to all capitals.
“□” is displayed in place of a folder name, title, artist name, or file name.	<ul style="list-style-type: none"> A character which cannot be displayed on the IC recorder has been used. Using your computer, replace it with one which can be displayed on the IC recorder.
The remaining recording time becomes shorter when you divide a file.	<ul style="list-style-type: none"> You need a certain amount of free space for a file management area to divide a file, therefore the remaining recording time will be shortened.

Trademarks

- Microsoft, Windows, Windows Vista and Windows Media are registered trademarks or trademarks of Microsoft Corporation in the United States and/or other countries.
- Macintosh and Mac OS are trademarks of Apple Inc., registered in the USA and other countries.
- Pentium is a registered trademark of Intel Corporation.
- MPEG Layer-3 audio coding technology and patents licensed from Fraunhofer IIS and Thomson.
- microSD and microSDHC logos are trademarks of SD-3C, LLC.



- Nuance, the Nuance logo, Dragon, Dragon NaturallySpeaking, and RealSpeak are trademarks and/or registered trademarks of Nuance Communications Inc., and/or its affiliates in the United States and/or other countries.

All other trademarks and registered trademarks are trademarks or registered trademarks of their respective holders. Furthermore, “™” and “®” are not mentioned in each case in this manual.

The “Sound Organizer” uses software modules as shown below:
Windows Media Format Runtime

This product contains technology subject to certain intellectual property rights of Microsoft.

Use or distribution of this technology outside of this product is prohibited without the appropriate license(s) from Microsoft.

Listening for a Lifetime

Selecting fine audio equipment such as the unit you've just purchased is only the start of your musical enjoyment. Now it's time to consider how you can maximize the fun and excitement your equipment offers. This manufacturer, the Consumer Electronics Association (CEA)[®] and the American Speech-Language-Hearing Association (ASHA) want you to get the most out of your equipment by playing it at a safe level; a level that lets the sound come through clearly without annoying blaring or distortion and, most importantly, without damaging your sensitive hearing.

Sound can be deceiving. Over time your hearing "comfort level" adapts to higher volumes of sound. So what sounds "normal" can actually be loud and harmful to your hearing. Guard against this by setting your equipment at a safe level **BEFORE** your hearing adapts.

TO ESTABLISH A SAFE LEVEL:

- Set your volume control to the lowest level where you can hear the music comfortably and clearly. Prolonged exposure to anything over 85 decibels can cause gradual hearing loss.
- Once you have established a sound level where you can hear the audio comfortably, clearly and without distortion, set the dial and leave it there.
- See if your music player has a volume limiter that allows you to set a safe listening level by establishing a maximum volume level on your player. This is a great solution for parents to ensure their children listen at a safe level.
- Limit listening time to give your hearing "quiet breaks."

BE SURE TO OBSERVE THE FOLLOWING GUIDELINES WHEN WEARING YOUR HEADPHONES OR EARBUDS:

- Do not turn up the volume so high that you can't hear sounds around you.
- Do not use headphones or earbuds while operating a motorized vehicle; it may create a traffic hazard and is illegal in many areas.

Used wisely, your new sound equipment will provide years of fun and enjoyment. Since hearing damage from loud noise is often undetectable until it is too late, this manufacturer, CEA and ASHA recommend that you avoid prolonged exposure to excessive noise. The following list of sound levels is included for your information so that you can better protect your hearing.

DECIBEL LEVEL EXAMPLES:

- 30 Whisper
- 40 Quiet room
- 50 Moderate rainfall
- 60 Normal conversation
- 70 Busy traffic, vacuum cleaner
- 80 Alarm clock

CONSTANT EXPOSURE TO THESE NOISES CAN BE DANGEROUS:

- 90 Lawn mower, motorcycle
- 100 Chain saw
- 110 Rock concert
- 120 Jet plane takeoff
- 130 Jackhammer
- 140 Firecrackers

This information courtesy of the American Speech-Language-Hearing Association (ASHA), the national professional, scientific and credentialing association for more than 135,000 audiologists, speech-language pathologists, and speech, language and hearing scientists. For information on protection against noise-induced hearing loss, call the ASHA Action Center (800-638-8255), Monday through Friday, 8:30 a.m. to 5 p.m. To find an audiologist in your area, visit www.asha.org/findpro. Parents can find helpful information about how to protect their children's hearing and how to teach them about safe listening at www.listentoyourbuds.org, an ASHA award-winning public education campaign sponsored in part by CEA.

A safety tip from the Consumer Electronics Association, 1919 South Eads Street, Arlington, VA 22202 and the American Speech-Language-Hearing Association, 2200 Research Boulevard, Rockville, MD 20850.

Index

A

- AAC-LC files 101
- Adjusting the volume 36, 44
- Alarm 52, 68, 75

B

- Battery indicator 18, 95
- Battery life 103
- Built-in memory 34, 81
- Built-in microphones 35

C

- Category 14, 28
- Changing a file name 66, 68, 71
- Changing a folder name ... 65, 68, 71
- Changing the Scene Select settings 41, 68, 72
- Connecting the IC recorder to your computer 18, 80
- Copying a file to the other memory 58, 68, 71
- Copying files to your computer 85
- Copying music files to the IC recorder 86
- Cue 50

D

- Display window 10
- Dividing a file at all the track mark positions 64, 68, 70
- Dividing a file at the current position 63, 68, 70
- DPC (Digital Pitch Control) 48, 68, 73

E

- Easy search 51, 68, 75
- Editing files 57
- Effect 46, 68, 74
- Erasing a file 54, 68, 70

- Erasing all files in a folder 56, 68, 70
- Erasing all the track marks 62, 68, 71
- Erasing a track mark 61, 68, 71

F

- Folder 28, 65, 81

H

- HOLD 13, 16
- Home menu 15, 26, 68

I

- Index to parts and controls
 - Display window 10
 - Front 8
 - Rear 9
- Inserting a microSD Card 32

L

- LPCM files 101

M

- Maintenance 97
- Menu
 - Alarm 68, 75
 - Beep 69, 77
 - Change File Name 68, 71
 - Change Folder Name 68, 71
 - Date&Time 69, 77
 - Divide All Track Marks 68, 70
 - Divide at Current Position 68, 70
 - DPC(Speed Control) 68, 73
 - Easy Search 68, 75
 - Effect 68, 74
 - Erase a File 68, 70
 - Erase All Files 68, 70
 - Erase All Track Marks 68, 71
 - Erase Track Mark 68, 71
 - File Copy 68, 71
 - Format 69, 78

Continued ↓

Language	69, 77
LCF(Low Cut)	68, 73
LED	69, 76
Menu operation modes	68
Menu Settings	70
Mic Sensitivity	68, 73
Move File	68, 70
Play Mode	68, 75
Power Saving Mode	69, 76
Protect	68, 70
REC Mode	68, 72
Save Destination	68, 72
Scene Edit	68, 72
Scene Select	68, 70
Select File	68, 70
Select Memory	68, 76
System Information	69, 78
Time Display	69, 77
VOR	68, 73
Messages list	112
microSD card	32, 34, 81, 98
Monitoring the recording	36
Moving a file	57, 68, 70
MP3 files	101

N

Noise	97
-------------	----

P

Pause recording	37
Playback	44
Playback speed	48
Playback time	103
Play modes	49, 68, 75
Podcasts	14, 89
POWER•HOLD switch	16, 20
Power Saving Mode	21, 69, 76
Precautions	97
Protecting a file	67, 68, 70

R

Recharging the battery	18, 95
Recording	35
Recording time	103

Remaining recording time	10, 116
Review	37, 50

S

Scene selection	39, 68, 70
Selecting a file in the stop or play mode window	30
Selecting a file using the menu	28
Selecting the memory	34, 68, 76
Setting the clock	22, 69, 77
Setting the language	25, 69, 77
Sound Organizer	89
Specifications	99
Standby mode	20
System limitations	116
System requirements	91, 99

T

Track mark	60
Troubleshooting	104

U

USB AC adaptor	95
USB Memory	88
Using the IC recorder with your computer	79

V

VOR (Voice Operated Recording)	43, 68, 73
---	------------

W

WMA files	101
-----------------	-----