

Read Me First!



Engineering the flow of communication™

1 Elmcroft Road
Stamford, Connecticut 06926-0700
www.pitneybowes.com

For Service or Supplies

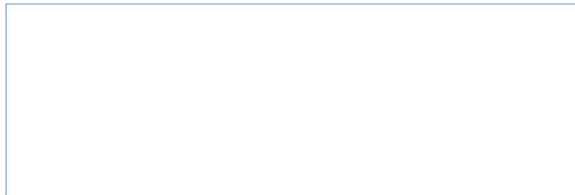

Support Web Site: www.pitneyworks.com/P700
Customer Support: 1(800)522-0020.
Product Name: DM100i
Model Number: P700

PB Form SV61130 Rev. C 01/04

© 2004 Pitney Bowes Inc.
All Rights Reserved
Printed in the USA

 Printed on recyclable paper



SV61130REVC



DM100i Quick Install Guide

Your new system has been designed to let you set it up on your own, so you can begin processing mail in just a short time.

Carefully following the sequence of steps presented in this guide will result in a successful installation.



US English Version

Contents

DM100i Mailing System

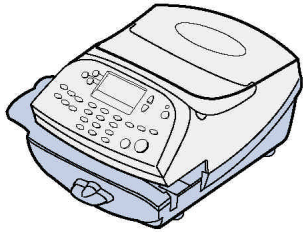

Stacker

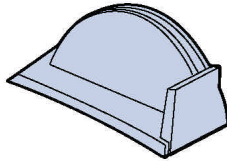

MP04 Weighing Platform (Optional)

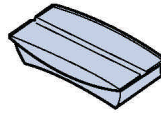

Moistener (Optional)



Ink Cartridge (Reorder # 793-5)



Print head

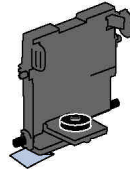

Tape Sheets

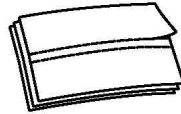

Phone Cord

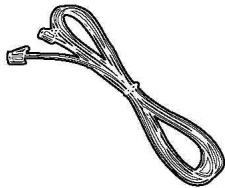

Power Cord



Phone Line Splitter



Operating Guide



Quick Install Guide



Basics Poster



Step 1

Remove all shipping tape attached to your meter.
Be sure to open the top cover and remove inside shipping tape.

 Please do not apply power to your DM100i until Step 4.

Step 2 Connect Phone Cord

The DM100i requires an analog phone line. Select a location for the system near an analog phone line and connect the phone cord.

 **ATTENTION:**
Most phone systems installed in businesses are not analog and may damage your DM100i. If you are unsure about your phone line contact your telephone company or local network administrator.

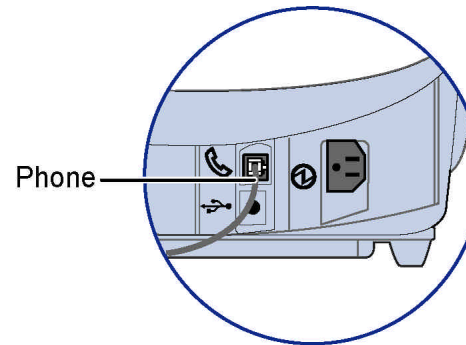

The following are usually analog lines:

- Fax lines
- Lines used by modems or credit card readers
- Residential phone lines
- A phone line splitter is supplied if you want to tap into the fax line.

Step 3 Install Weighing Platform

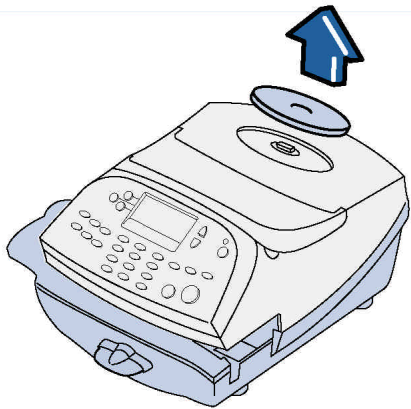

If you have purchased the optional weighing platform for your DM100i, remove the connector cover.

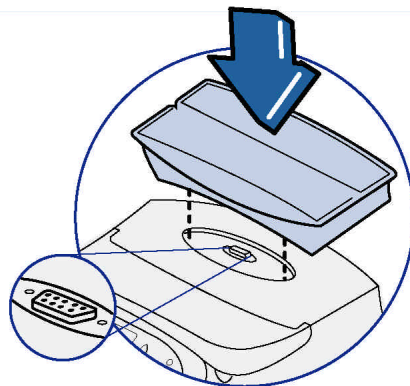

Position the weighing platform as shown. Plug the connector on the weighing platform into the matching connector on the DM100i.

Step 4 Connect Power

Plug the power cord into a convenient outlet.

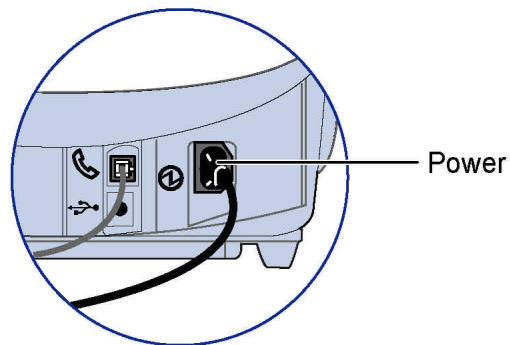

Step 5 Set Time

After powering on your DM100i, you will see the following screen.

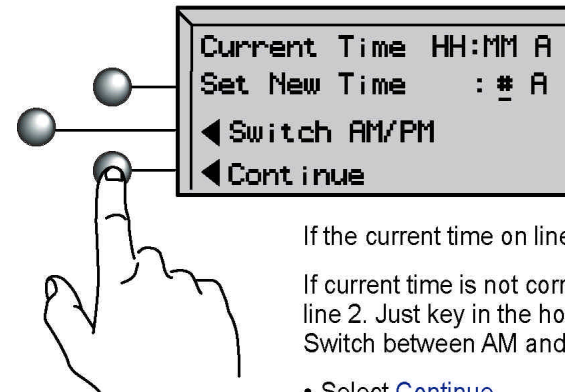

! ATTENTION:
Don't forget to check AM/PM setting on line 2.

If the current time on line 1 is correct, select **Continue**

If current time is not correct, enter the correct time on line 2. Just key in the hours first and then minutes. Switch between AM and PM if necessary.

- Select **Continue**.

Step 6 Install the Print Head

The following screen will appear.

No Print head detected. Open cover to install print head.

Please install print head and ink tank. Close cover to continue.

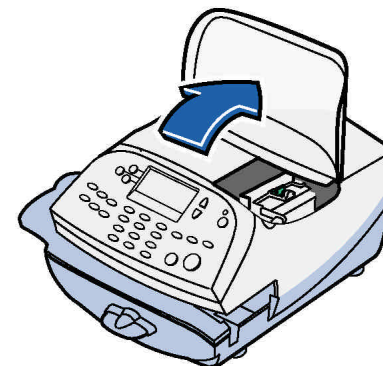

A Open access cover.

B Flip open the guard.

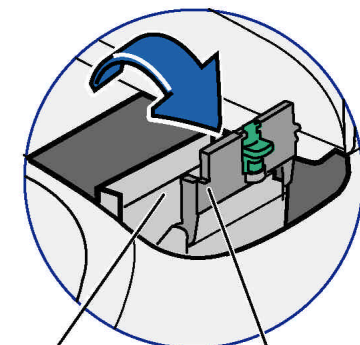

Print head Cavity

Ink Cartridge Guard

Step 6 Install the Print Head (continued)

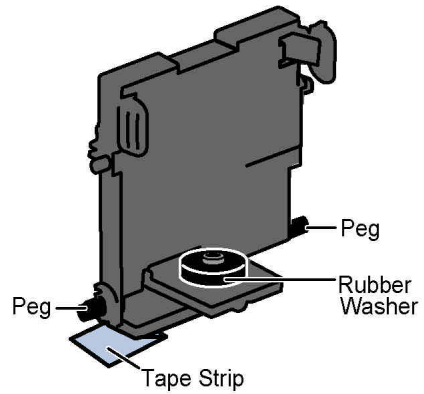

- C** Remove print head from packaging.

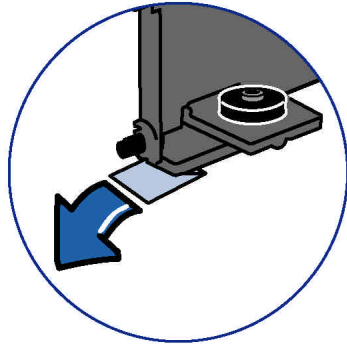

- D** Remove tape strip from print head.

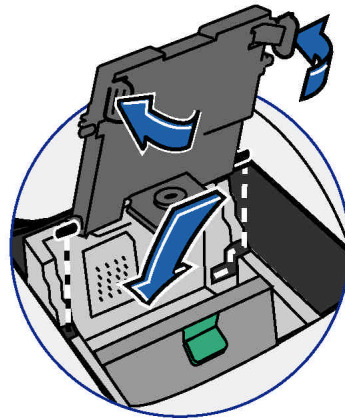

- E** Slide the print head pegs down into the grooves.

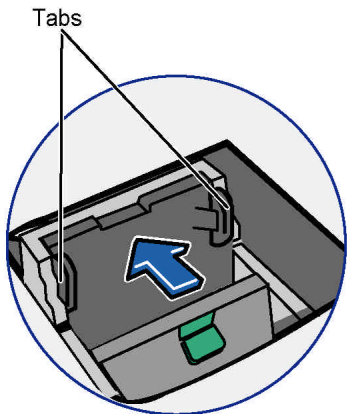

- F** Squeeze the tabs on the sides of the print head and push the print head flush against the wall.

Step 7 Install the Ink Cartridge

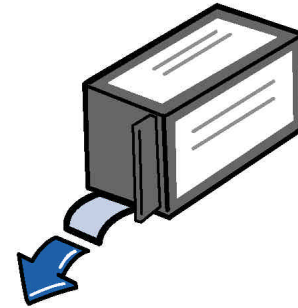

- A** Remove tape on bottom of new ink cartridge.

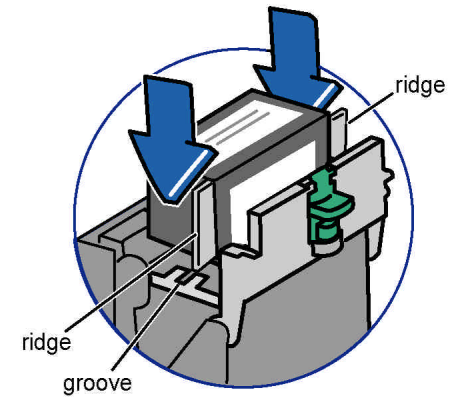

- B** Lower the cartridge into the cavity. The ridges on either side of the cartridge will slide into the grooves.

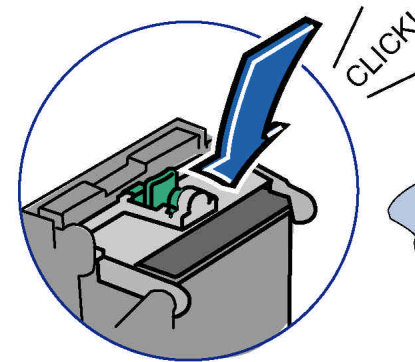

- C** Return the guard back to the operating position and click to close.

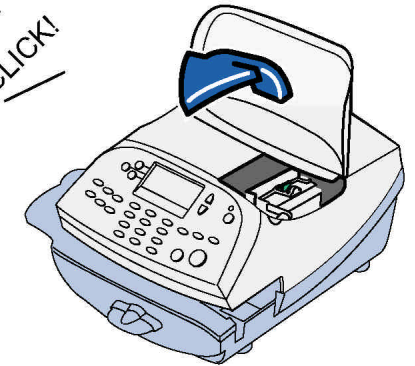

- D** Close the cover. The system will automatically start the printer installer procedure.

Step 8 Create a Test Print

When prompted, insert a spare envelope or a tape sheet for a test print.

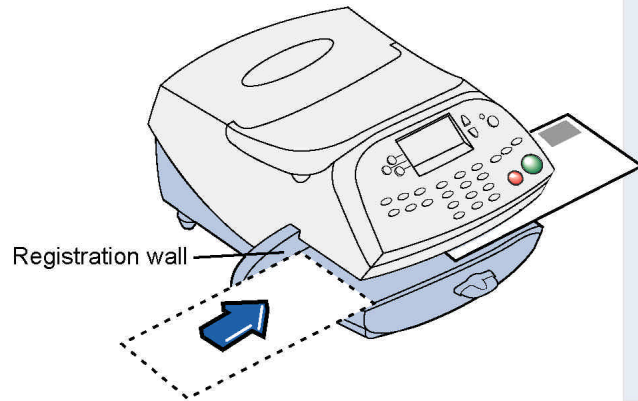

To print correctly, position mail flush against rear registration wall and gently slide mail to the right on feed deck.

The system will detect the envelope and automatically guide it through the printing mechanism.

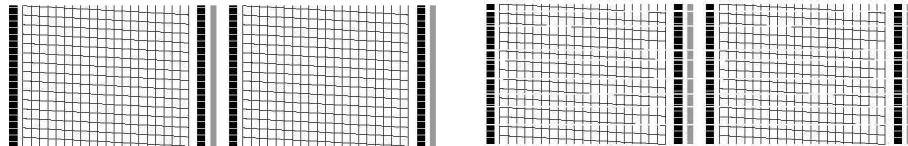

Good test print - no missing lines

Poor test print

If the test print is good, press **Yes** on control panel.

If the test print is poor, press **No** to perform additional maintenance.

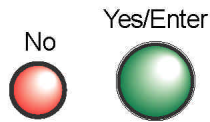

Step 9 Scale Location

If you have purchased the optional weighing platform, key in the correct scale code for your location. These codes can be found in the back of this guide.

- Select **Continue**.

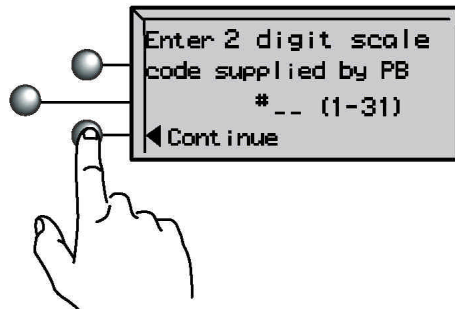

Step 10 Contact Pitney Bowes Data Center

You have to add postage funds to your meter before you can use it.

If your phone requires a prefix for an outside line (for example, if you have to dial 9) press the **Yes** key.

If you are using the same analog line as the fax machine, check if the fax requires a dialing prefix.

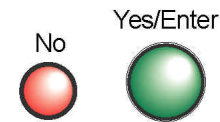
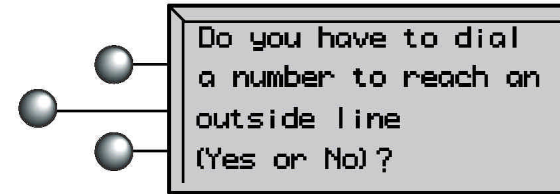

If you select Yes, key in your dialing prefix and select **Continue**.

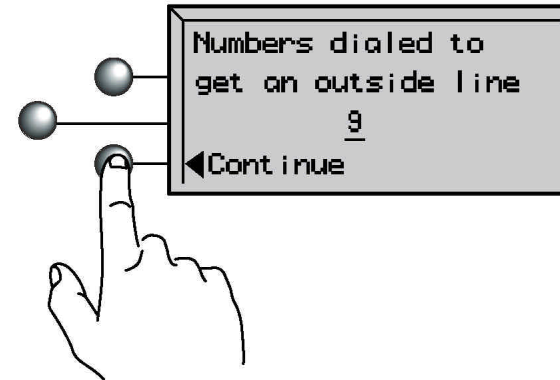

If you select No, your system will automatically dial the Data Center.

Step 11 Check Your Account Balance

Your DM100i system will automatically dial the Postage By Phone™ Data Center and after a brief delay, display your Postage By Phone™ balance.

- Select **Continue**.

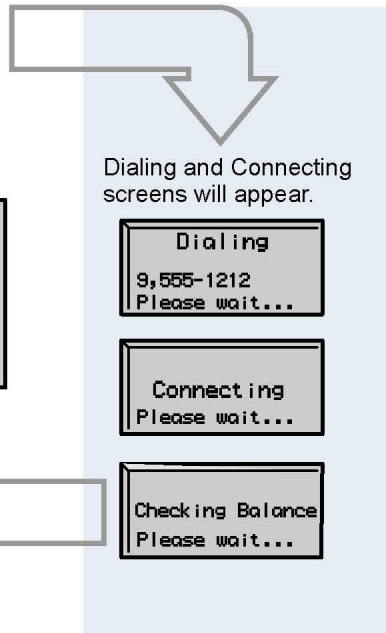
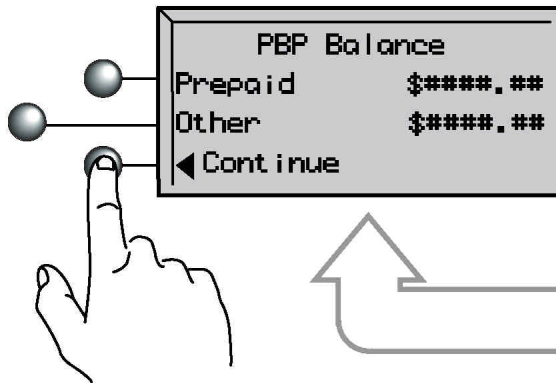

NOTE: If a software system update is available, you will be informed at this time.

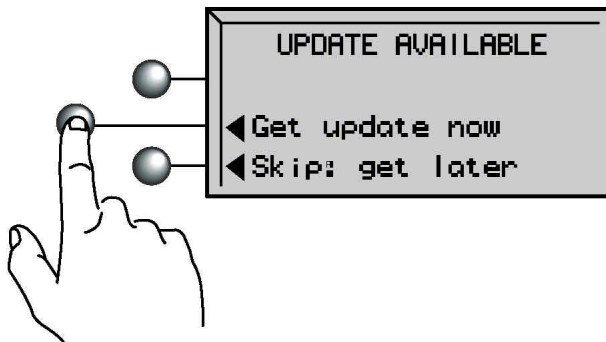

- Select **Get update now**.

The value-added features and options that you selected as part of your order will take a few minutes to download

- Select **Continue**.

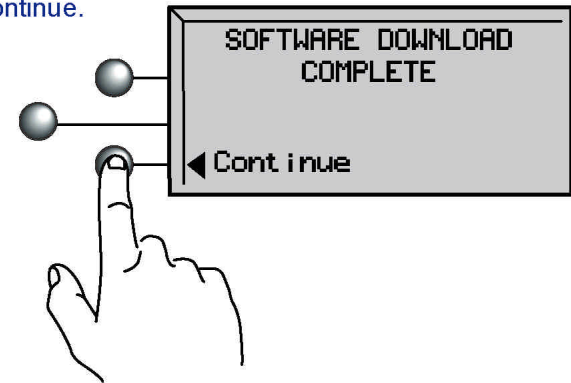

Step 12 Load Postage Into Your System

Key in the amount of postage you wish to add. You can enter whole dollar amounts only. Select **Continue**.

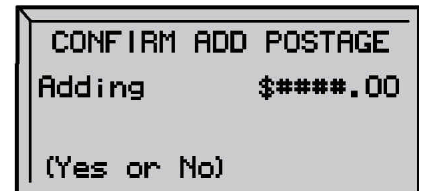

Dialing and Connecting screens will appear.

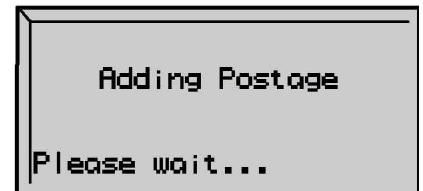

Press **Yes** or **No**.

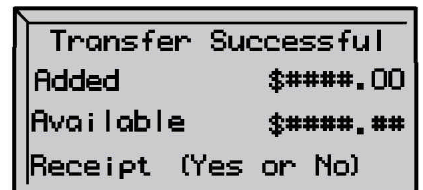

Step 13 Print Your Receipt

If you choose to print a receipt follow the display instructions.

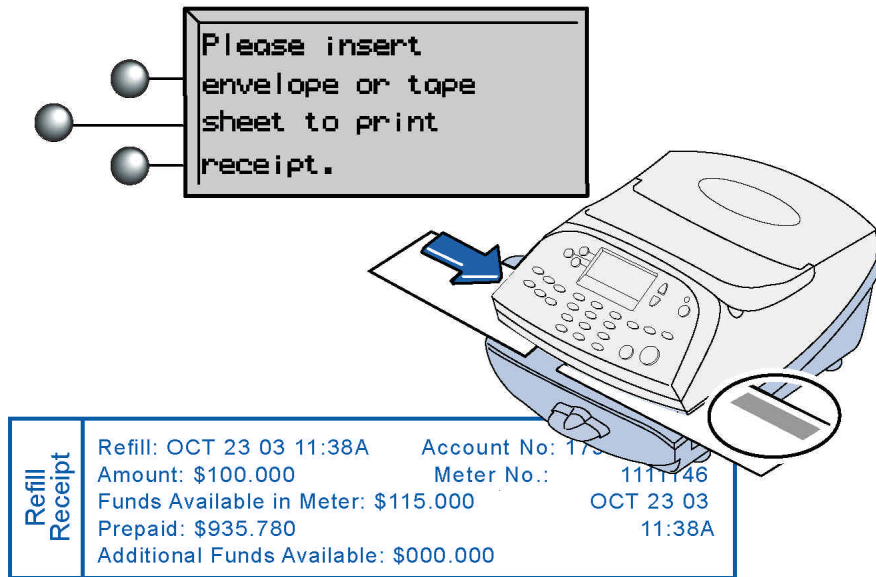

Step 14 Congratulations! Your Mailing System is Operational

Select OK.

Your system is ready to use.

To customize your postage settings and learn all about using your DM100i, see the Operating Guide.

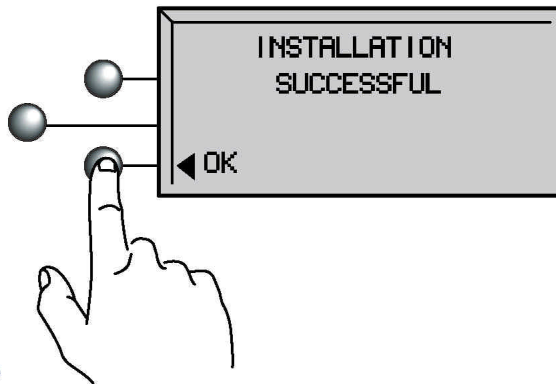

Still have questions?

See Troubleshooting on page 12 or go to www.pitneyworks.com/P700 or call: 1-800-522-0020. Reference Model P700.

Continue to setup optional moistener and stacker.

Install Moistener

If you have purchased the optional moistener with your DM100i, position the moistener on the left side of the transport deck as shown.

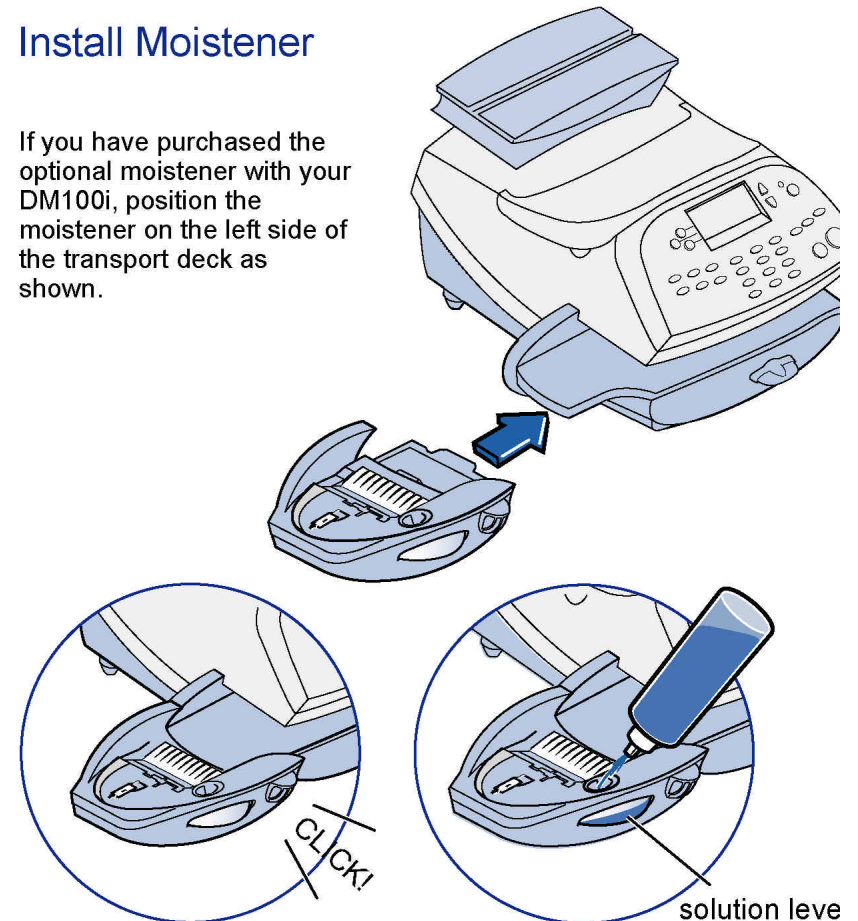

The moistener will click into place.

Fill the moistener reservoir with Pitney Bowes E-Z Seal™ sealing solution. You may fill it later if you don't plan on moistening and sealing envelopes right now.

Position Stacker

Position the stacker next to the DM100i as shown. The stacker provides a convenient location to store your stamped mail, tape sheets and operator guide.

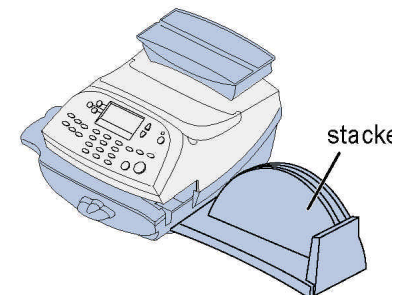

Scale codes for locations in the United States



Locations near a boundary may enter either code.

State	Code	State	Code
Alabama		Illinois	
Birmingham and north	13	North of Springfield	16
South of Birmingham	12	Springfield and south	15
Alaska (see map on pg 15)		Indiana	
Arizona		North of Indianapolis	16
Phoenix and north	12	Indianapolis and south	15
South of Phoenix	11	Iowa	
Arkansas	13	North of Des Moines	17
California (see map on pg 15)		Des Moines and south	16
Colorado		Kansas	
Denver and north	13	North of Wichita	15
South of Denver	12	Wichita and south	14
Connecticut	16	Kentucky	14
Delaware	15	Louisiana	12
Florida		Maine	18
W Palm Beach and north	11	Maryland	15
South of W Palm Beach	10	Massachusetts	17
Georgia	12	Michigan	
Hawaii	9	NW of Lake Michigan	18
Idaho		SE of Lake Michigan	17
N of Salmon River Mtns.	17	Minnesota	18
S3 of Salmon River Mtns.	16	Mississippi	
		Kosciusko and north	13
		South of Kosciusko	12

Scale codes for locations in the United States

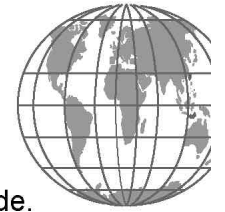

Locations near a boundary may enter either code.

State	Code	State	Code
Missouri		Oregon	
North of Springfield	15	Salem and north	18
Springfield and north	14	South of Salem	17
Montana		Pennsylvania	16
Helena and north	18	Rhode Island	16
South of Helena	17	South Carolina	13
Nebraska	16	South Dakota	17
Nevada	13	Tennessee	13
New Hampshire	17	Texas	
New Jersey	16	NE of Colorado River	12
New Mexico	11	SE of Colorado River	11
New York		Utah	13
Kingston and north	17	Vermont	17
South of Kingston	16	Virginia	
North Carolina		North of Roanoke	15
Raleigh and north	14	Roanoke and south	14
South of Raleigh	13	Washington DC	15
North Dakota	18	Washington State	18
Ohio		West Virginia	15
Akron and north	16	Wisconsin	
South of Akron	15	Green Bay and north	18
Oklahoma		South of Green Bay	17
North of Oklahoma City	14	Wyoming	15
Oklahoma City and south	13		

Scale codes for locations in Alaska and California



Locations near a boundary may enter either code.

