

COSCO®

Sprinter Stroller

Model 01070

User Guide

Questions? Comments?
Missing Parts? Contact us:

www.coscojuvenile.com



**Spanish Guide Included
Incluye guía en español**

©2009 Dorel Juvenile Group.
All Rights Reserved.

Todos derechos reservados.
www.djgusa.com (800) 544-1108

www.coscojuvenile.com

Made in CHINA. Hecho en CHINA.

Styles and colors may vary.

Los estilos y los colores pueden variar.

Distributed by (distribuido por)

Dorel Juvenile Group, Inc.,

2525 State St., Columbus, IN 47201-7494

Dorel Distribution Canada,

873 Hodge, St. Laurent, QC H4N 2B1

03/30/09 4358-4786

Using Your Stroller

To Use Child's Tray

1. Guide tray tabs into slots on stroller frame. Push until tray clicks into place. To remove tray, pull out finger tabs on both sides and slide tray out.

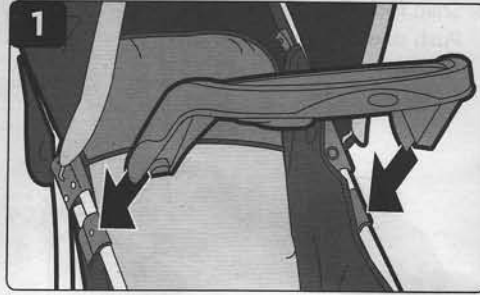

To Use Brakes

1. Step down onto levers on both rear wheels. To park stroller, **BOTH BRAKES MUST BE LOCKED**. Lift up levers to unlock brakes.

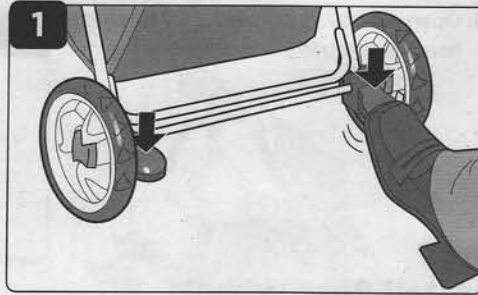

To Adjust Seat Position

1. **To lower seat back:** Locate release clip behind backrest. Squeeze release clip, pull away from the stroller and lower seat back.
2. **To raise seat back:** Holding the ring on the strap, squeeze release clip and push toward the seat back (Figure 2).
NOTE: DO NOT adjust the seat when your child is in the stroller.

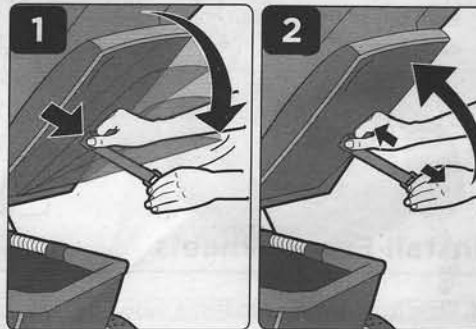

Using Your Stroller

To Use Restraint System

WARNING

- **NEVER LEAVE CHILD UNATTENDED. ALWAYS** keep child in view when in stroller.
- **AVOID SERIOUS INJURY** from falling or sliding out. **ALWAYS** use seat belt. Check frequently to make sure it is secure.
- Belts must be threaded exactly as shown (Figure 1b).
- Failure to follow these instructions could result in the serious injury or death of your child.

1. Place your child in the stroller, with the crotch strap between the child's legs. Fasten both buckles (Figure 1).

Tighten straps: Pull out bottom loop to desired tightness, then pull on strap end. (Figure 1a).

Loosen straps: Pull out bottom loop for slack, then pull out top loop to desired looseness, then pull on the buckle.

NOTE: If the straps should come out of the buckle, rethread A - D as shown (Figure 1b).

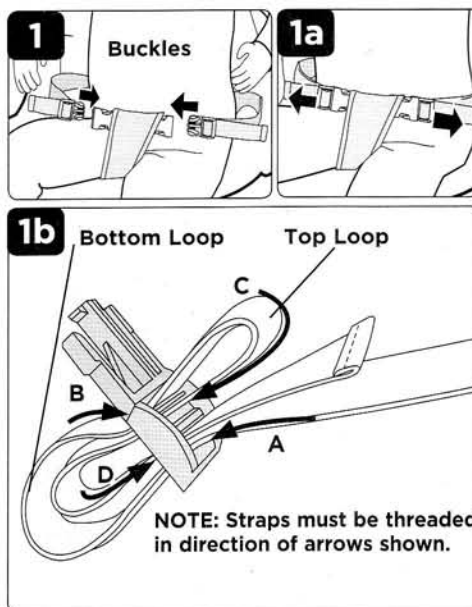

Using Your Stroller

To Fold Stroller

1. Lock rear brakes and remove your baby. Close canopy. Slide the button on handlebar to the left and squeeze.

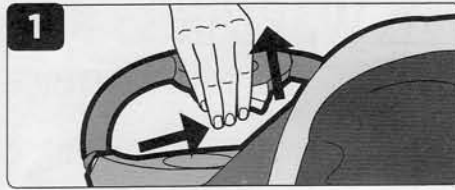

2. Hold the button in and push the handlebar down.



3. Secure the stroller latch onto the post stroller frame tube. Stroller will stand alone.

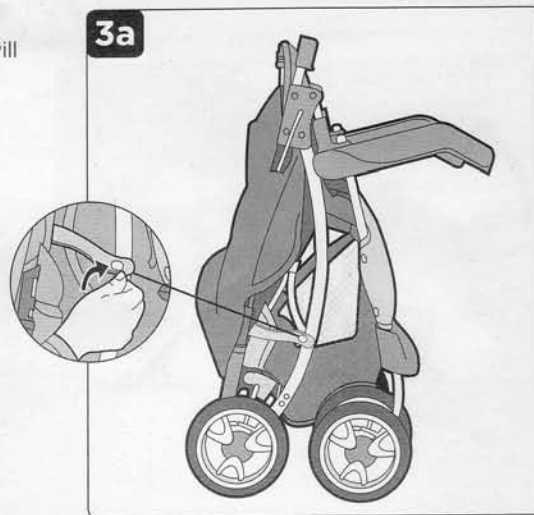

To Install Designer 22 Infant Car Seat

WARNING

To avoid serious injury:

- Use **ONLY** Designer 22 infant car seats with the Travel System.
- Please refer to the manufacturer's instructions for the use of your infant car seat.
- **ALWAYS** use child's tray when car seat is installed.
- **ALWAYS** install car seat facing to the rear of the stroller.
- **ALWAYS** use the restraint system in the car seat.
- Place adapter bar in storage position behind seat back when not in use.

1. Remove adapter bar from behind seat back.

Recline seat back to lowest position.

Close canopy.

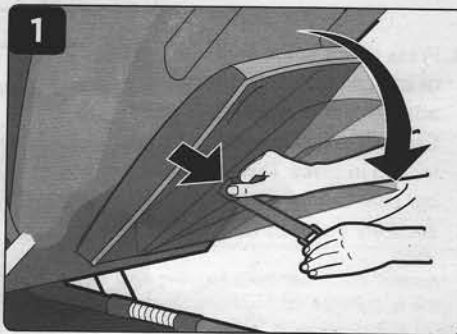

2. Insert the rigid end of adapter bar into hole inside stroller frame. Move fabric to get better access to the hole inside the frame. Push in spring end and insert into the hole on the other side. Test to make sure bar is securely installed.

NOTE: Make sure no fabric is caught between the ends of the adapter bar and holes in frame.

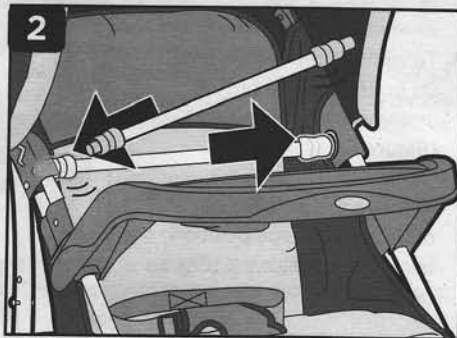

Using Your Stroller

To Install Designer 22 Infant Car Seat, continued:

- 3. Car seat must be positioned so that child faces the stroller handle.** Lower the car seat down so the rear rests inside the child's tray. The channel at the front of the car seat should rest on the adapter bar.

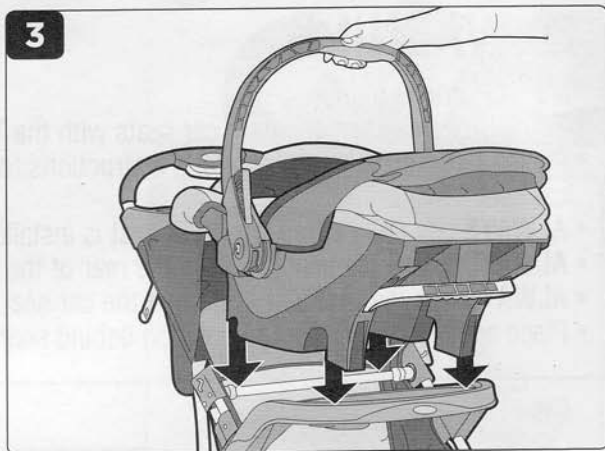

- 4. Press down in the well of the car seat onto the adapter bar (Figure 4). Car seat will click when locked in place. Pull up on car seat to make sure it is securely installed (Figure 4a).**



- 5. To remove the car seat, pull up on the release button underneath the head rest (Figure 5).**

Remove the adapter bar and replace in storage position behind the seat back (Figure 5a).

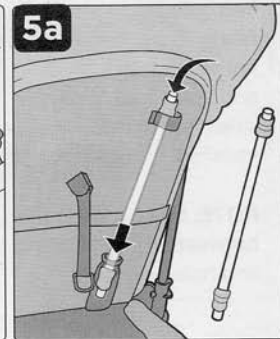
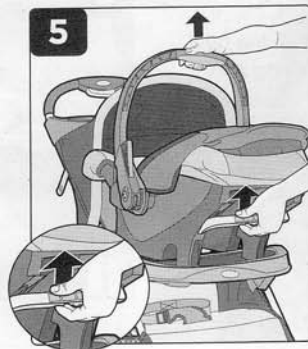

Eng. GB4358-3394E

**First Ride, Starter,
Designer 22,
Deluxe Infant Seat
Instruction Manual**

www.djgusa.com

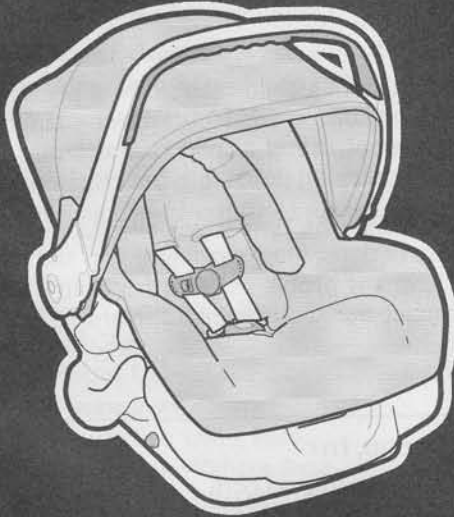

This child restraint is designed for use by children whose:

Weight:
5-22 pounds
(2.3-10 kg)

Height:
19-29 inches
(48-74 cm)

Read all instructions
BEFORE USING
this child restraint.

KEEP INSTRUCTIONS FOR FUTURE USE.

▲ IMPORTANT!

Failure to follow the warnings on the labels and in the instruction manual can result in the death or serious injury of your child.

Para recibir las instrucciones en español, llame al 1-800-544-1108 o solicítase por escrito al dirección por arriba.

WARNING

Failure to follow these warnings can result in the serious injury or death of your child. To help you recognize those instructions which are most critical to your child's safety, we use this symbol :

 According to accident statistics, children are safer when properly restrained in the rear seating positions than in the front seating positions.





 Never place a child in front of an airbag in the rear-facing position. Death or serious injury can occur.

 This child restraint must always face the rear of the vehicle.

 This restraint must only be used when the child weighs between 5-22 lbs. (2.3-10 kg).

 Never place a child less than one year old forward facing.

 Check vehicle instructions for more information about air bag/child restraint use.

 For vehicles with an air bag, but without a back seat, refer to your vehicle owner's manual.

 Make sure the harness height is correct for your child's size.

 The harness must be snug.

2

WARNING

 The vehicle or LATCH belt must stay tight at the belt path. If it's not, your child could be injured or killed.

 Never take your child out of the child restraint or try to tend to your child's needs while the vehicle is moving. Never leave child unattended.

 Do not use a child restraint with damaged or missing parts.

 Do not use cut, frayed or damaged harness straps.

 Do not substitute parts or try to modify the child restraint in any way.

 Do not use a child restraint that has been in a crash. You must get a new child restraint.

 Use the child restraint only on vehicle seats that face forward. Do not use on seats that face the sides or rear of the vehicle.

 Check the vehicle or LATCH belt before each use. Use only if the belt can be tightened properly and securely.

 This child restraint should be securely belted in the vehicle even when not in use. In a crash or sudden stop, an unsecured child restraint could injure other occupants.

 Never allow any child to play with this child restraint; it is not a toy.

3

WARNING

- ▲ **Do not lubricate buckles and fasteners.**
- ▲ **Do not use this child restraint when the top of your child's head comes within one inch of the top of the child restraint's head area.**
- ▲ **Dorel Juvenile Group does not recommend the use of any child restraint accessories except those provided by DJG.**
- ▲ **Do not remove any of the warning labels or other labels on the child restraint.**
- ▲ **Placing your child in a hot child restraint may result in burns.**
- ▲ **Read instructions for other warnings.**

4

General and Warm Weather Use

To help protect your vehicle seat's upholstery from damage, use a towel underneath and behind child restraint.

To avoid your child being seriously burned, take the following precautions:

1. Park in the shade or where sun does not directly hit the child restraint.
2. Cover the child restraint with a sheet or blanket when not in use.
3. Check for hot seat and buckles before placing child in child restraint.

Registration and Recall Information

Child restraints could be recalled for safety reasons. You must register this restraint to be reached in a recall. Send your name, address and the restraint's model number and manufacturing date to:

Dorel Juvenile Group, Inc.
PO Box 2609, Columbus, IN 47202-2609
Attn: Consumer Relations or visit www.djgusa.com
or call 1-800-544-1108

For recall information, call the U.S. Government's Vehicle Safety Hotline at 1-888-327-4236 (TTY: 1-800-424-9153), or go to <http://www.NHTSA.gov>.

Aircraft Installation

This child restraint is certified for aircraft use. Use on forward-facing aircraft seats only and in a position where the lap belt can be tightened securely. This child restraint is installed in an aircraft seat the same way it is installed in a vehicle.

Use the child restraint only with F.A.A. certified equipment. Contact the airline prior to taking a child restraint on board in order to comply with their specific regulations.

5

Understanding Your Vehicle

Your vehicle's features may be considerably different than those pictured here. Consult your vehicleowner's manual to help identify your vehicle's specific features.

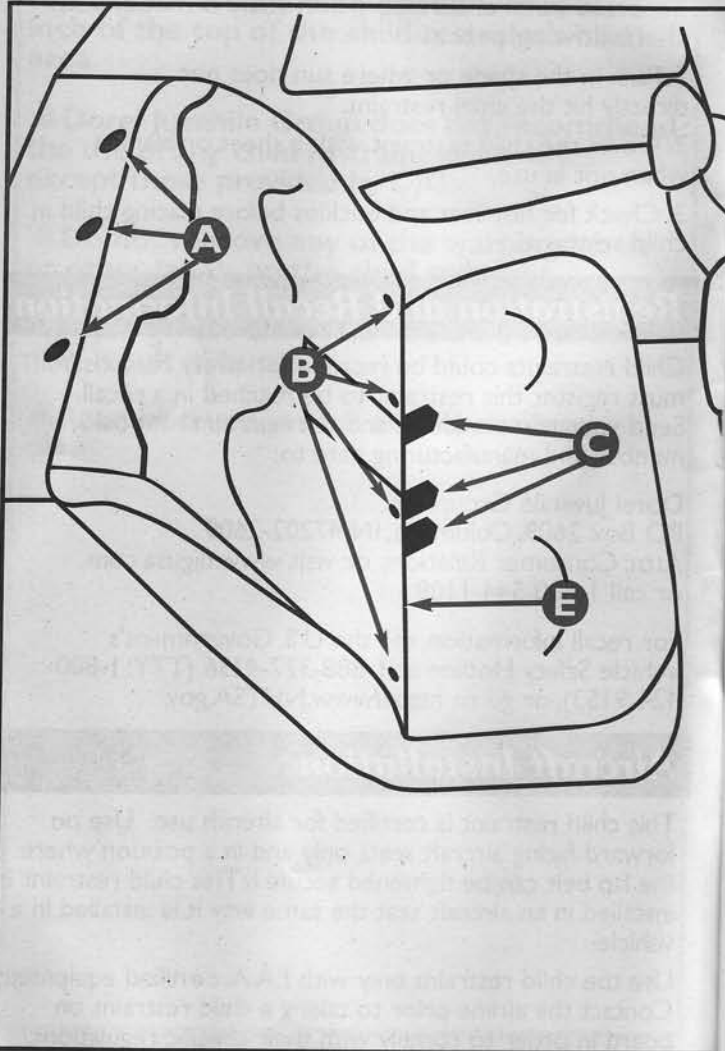

6

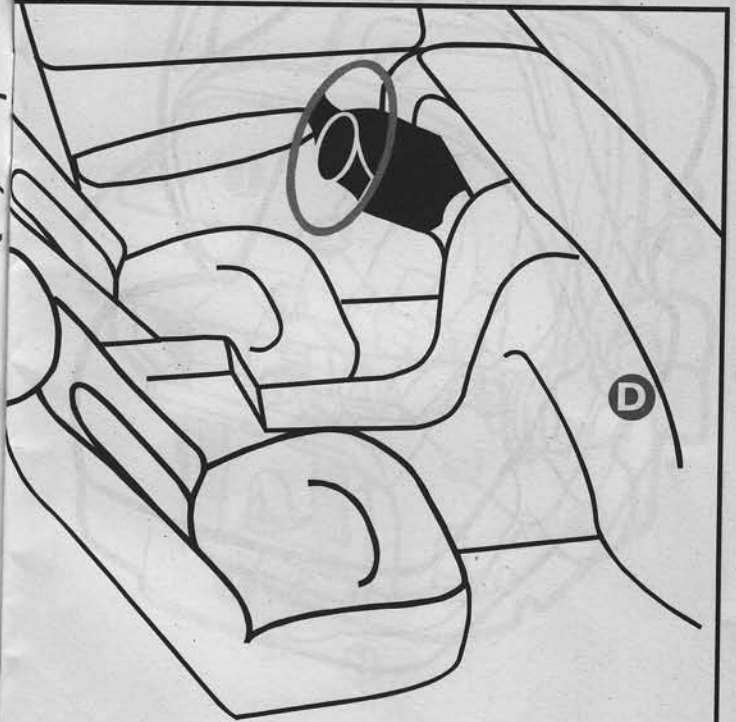

7

- A. Anchor Bracket**
For Top Anchorage Strap
(Forward-Facing Only)
- B. LATCH Anchors**
(In seat bight)
- C. Seat Buckles**

- D. Air Bag**
(Consult your vehicle
owner's manual for all air
bag locations)
- E. Seat Bight**
(Where seat cushions
meet)

Child Restraint Parts

Front

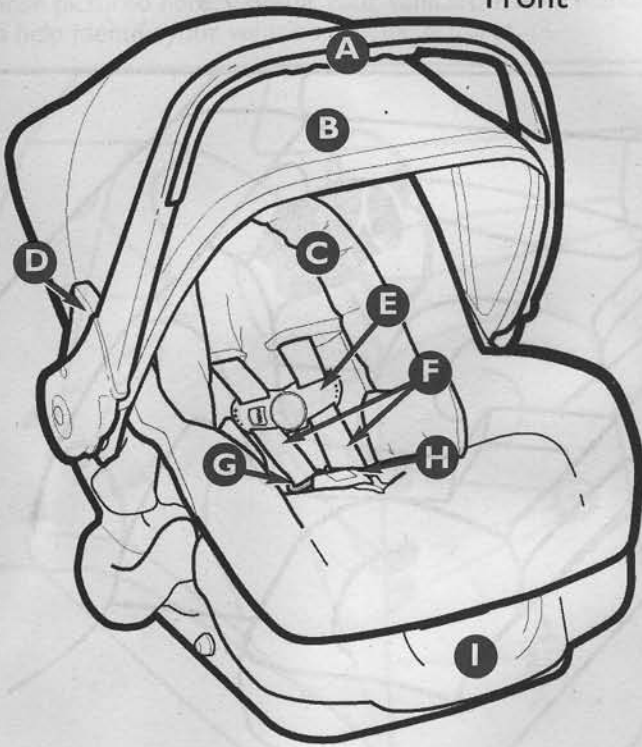

- A. Handle
- B. Canopy
- C. Head/Hip Roll
(on select models)
- D. Handle Adjustment
Lever
- E. Harness Retainer
(one or two piece)
- F. Harness Straps
- G. Buckle Plate
- H. Buckle Release
Button
- I. Removable Base

Back

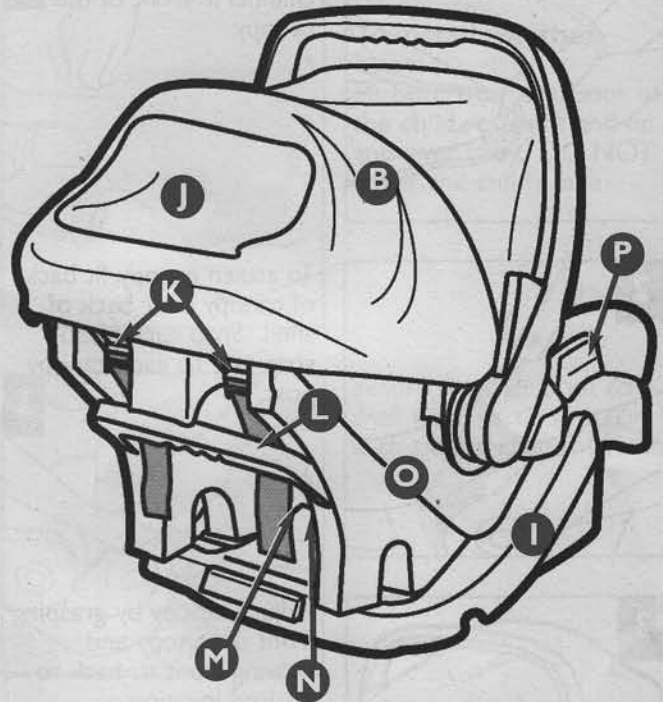

- J. Canopy Window
(on select models)
- K. Harness Adjustment
Brackets
- L. Base Release
Handle
- M. Locking Clip
(under child restraint)
- N. Instructions
(under child restraint)
- O. Shell (child restraint)
- P. Level to Ground
Line

Choosing Restraint and Position

Rear-Facing

5-22 lbs (2.3-10 kg) AND 19"-29" tall (48-74 cm).

NOTE: If your child does not meet the criteria for the Rear-Facing position, do not use this child restraint!

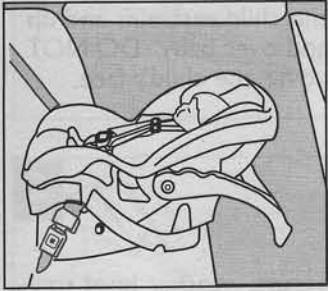

Rear-Facing with base:
Child and child restraint with base face the back of the vehicle and are placed in the back seat.

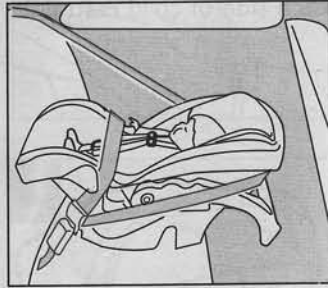

Rear-Facing without base:
Child and child restraint without base face the back of the vehicle and are placed in the back seat.

12

Preparing Child Restraint to Fit Your Child

You MUST make these adjustments with your child before you install the child restraint in the vehicle.

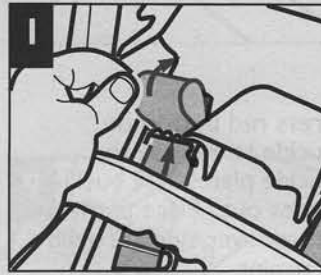

From the back of the child restraint, loosen the free end of harness from harness adjustment bracket to make a loop.

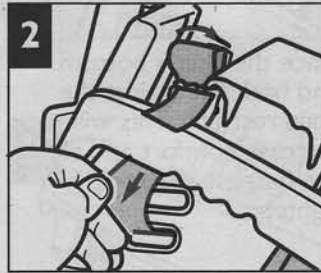

Pull down on harness at the harness slot to remove the loop at the harness adjustment bracket.

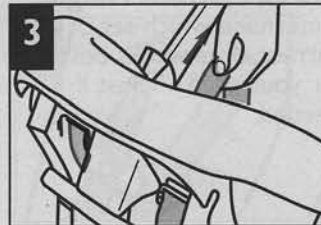

From the front of child restraint, pull on harness to loosen. Repeat for other adjustment bracket.

13

continued on next page.

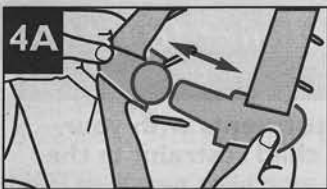

Depending on your model, press on harness retainer release button and pull apart (4A) **OR** push down on tab (4B) and slide harness out.

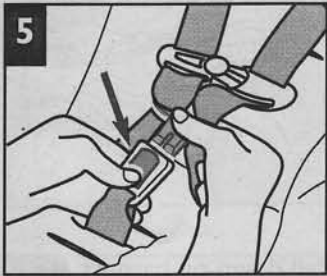
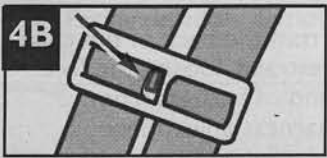

Press red button on buckle to release the buckle plates. Pull buckle plates out. Place harness straps over sides of child restraint.



Place the child's bottom and back flat against the child restraint. This will increase comfort and allow the harness to properly tighten.

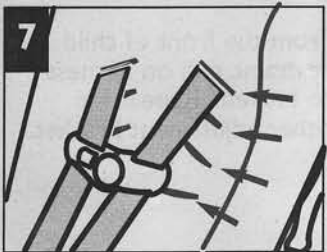

Check Harness Height: Determine which set of harness slots works best for your child. Adjust if needed.

14

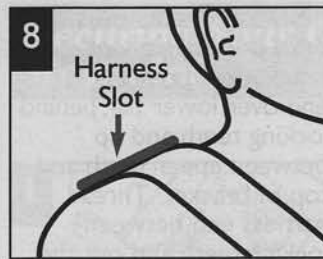

Harness slot being used must be even with or just below the shoulders.

If the bottom harness slots are above the child's shoulders, **do not** use this child restraint until the child grows into it.

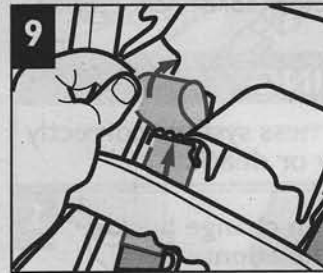

From the back of the child restraint, remove free end of harness from harness adjustment bracket.

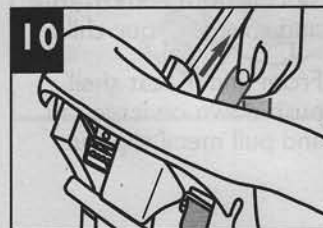

From the front of child restraint, pull harness strap out. Repeat for other adjustment bracket.

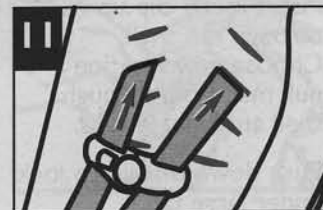

Rethread harness into new harness slot location. Make sure harness straps do not twist.

15

continued on next page.

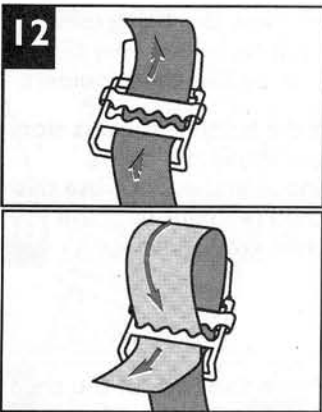

12 Rethread one harness end onto one adjustment bracket by threading loose end over lower bar, behind locking teeth and up between upper teeth and top of bracket. Thread harness end between locking teeth and out the bottom of bracket as shown. Make sure harness does not twist. Repeat for other adjustment bracket.

⚠ WARNING

Failure to reinstall the harness system correctly can result in serious injury or death.

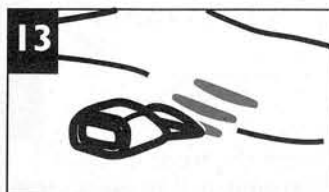

13 **To change buckle location:** Determine which of the three available buckle slots is both comfortable and snug for your child.

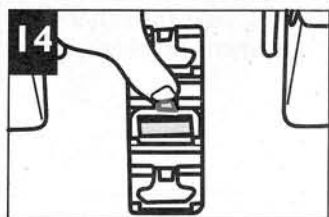

14 From under seat shell, push down on large tab and pull metal clip out.

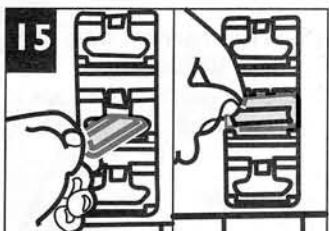

15 Insert metal clip up through the shell. Choose new location and pull metal clip through shell and behind tabs.

Push down on clip to lock under large tab.

16

Securing Your Child in the Child Restraint



1 Position harness straps over the child's shoulders.

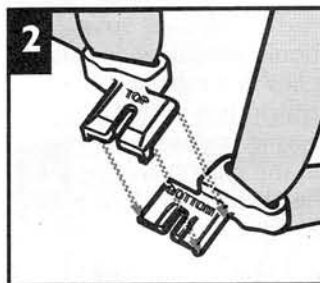

2 Fit top buckle plate over bottom buckle plate. The connection should be locked together.

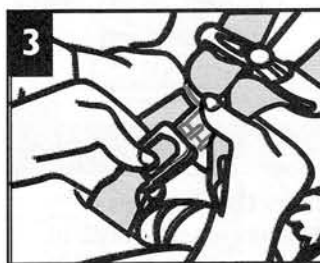

3 Hold buckle plates together with one hand and buckle with the other. Push buckle plates into buckle until you hear a "click." Pull up on harness to make sure buckle is locked.

17

continued on next page.

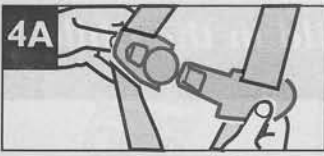

Depending on your model, snap the harness retainer together (4A) **OR** thread harness into harness retainer (4B).

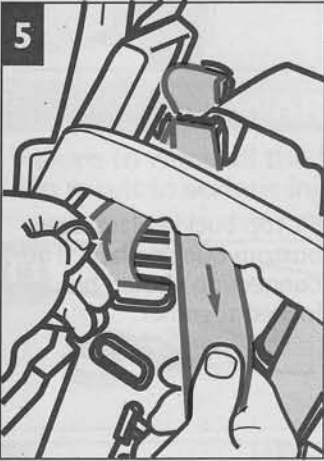
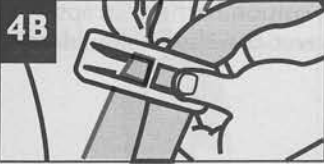

Pull harness strap away from shell at the harness slot to tighten harness snugly. Pull on free end of harness strap to remove slack.

NOTE: A snug strap should not allow any slack. It lies in a relatively straight line without sagging. It does not press on the child's flesh or push the child's body into an unnatural position.



Position the harness retainer at mid-chest (even with armpits), away from the child's neck.

⚠ WARNING:

Failure to fasten and tighten the harness system correctly with each use can result in serious injury or death.

Removing Your Child from the Child Restraint

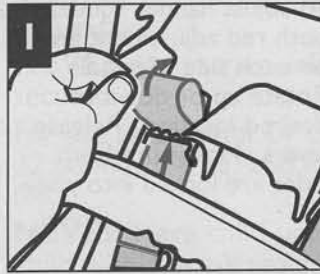

From the back of the child restraint, loosen the free end of harness from harness adjustment bracket to make a loop.

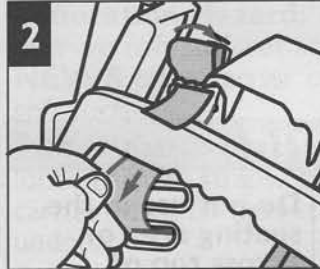

Pull down on harness at the harness slot to remove the loop at the harness adjustment bracket to loosen.

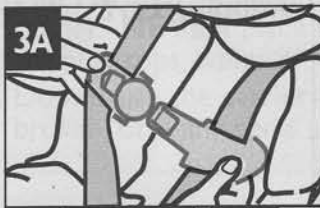

Depending on your model, press on harness retainer release button and pull apart (3A) **OR** push down on tab and slide harness out (3B).

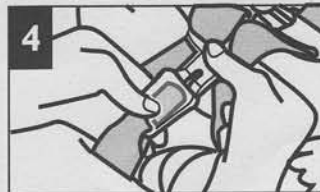

Release harness by pressing red button on buckle. Remove child.

Carrier Use

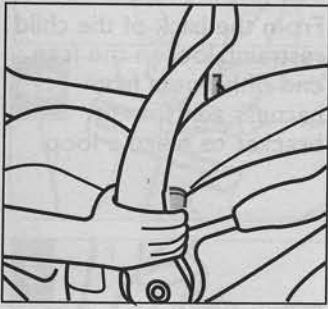

To adjust handle, squeeze both red adjustment levers on each side of handle. Rotate up or down to desired location. Release levers. Make sure both sides are locked into place.

! WARNING:



Do not use in the seating area or across top of shopping cart.

! WARNING

Read ALL instructions before using child restraint as a carrier.

NEVER use carrier unless child is properly secured.

For use as a carrier by children weighing less than 22 pounds (10 kg) and less than 29 inches (74 cm) tall.

NEVER leave child unattended. Always keep child within arm's reach.

Suffocation Hazard: Infant carrier can roll over on soft surfaces and suffocate child.

NEVER place carrier on beds, sofas or other soft surfaces.

Strangulation Hazard: Child can strangle in loose harness straps. **NEVER** leave child in carrier when harness straps are loose or undone.

Fall Hazard: Child's movement can slide carrier. **NEVER** place carrier near edges of counter tops, tables or other elevated surfaces.

Do not use the carrier if it is damaged or broken, or if any parts are missing.

Choosing LATCH or Vehicle Belts

The LATCH System

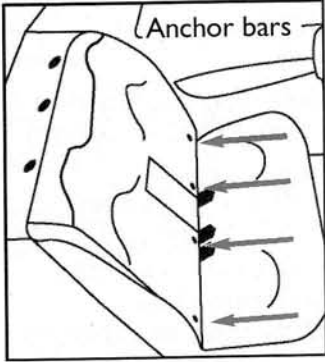

LATCH means **L**ower **A**nchors and **T**ethers for **C**hildren. Not all vehicles manufactured before September 2002 were equipped with LATCH.

The LATCH system allows a child restraint to be secured in the vehicle without using the vehicle belt system and can **ONLY** be used in vehicles that have the anchor bars installed.

Check your vehicle owner's manual to see which seating positions may be equipped with the LATCH system.

Vehicle Belts



If LATCH is not an option, you will use your vehicle's belts. There are some vehicle belts that will not work with a child restraint or will require special attention. See next page for specific instructions.

22

Knowing Your Vehicle Belts

Not all vehicle belts will work with this child restraint. You must determine if your vehicles belts are compatible with this child restraint. If you will use the LATCH system, refer to the LATCH section.

ELR - Emergency Locking Retractor Belts

Definition: These belts only lock in a sudden stop or crash. To see if you have this type of belt, pull on the lap belt, let it return part way, then pull on it again. If it moves freely, it is an ELR belt and the child restraint could work loose during normal driving. Refer to your vehicle owner's manual.

ELR shoulder belts either require a locking clip or cannot be used with any child restraint.

ELR lap-only belts must be replaced with a manual belt; contact your vehicle dealer. A locking clip will not correct this problem.

Automatic/Passive vehicle seat belts

The automatic (passive) 2-point belt has no lap belt. You must install a lap belt to secure a child restraint. You may also need to install an extra lap belt for an automatic 3-point belt. Refer to the vehicles owner's manual. A locking clip will not correct this problem.

Vehicle belt too short

Contact your vehicle dealer for a seat belt extender.

Belts in center of the door or side panel (A) or middle of the vehicle seat cushion (B).

You must move the child restraint to another seating location. A locking clip will not fix this problem.

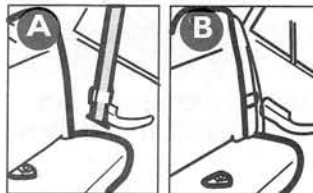

See "Locking Clip" section.

23

continued on next page.

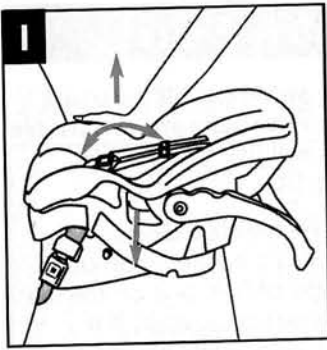

Manual Belts

Manual lap belts are common in the center rear seat and can allow the child restraint to loosen when it is tilted or jarred. After tightening the lap belt securely, tilt and push the child restraint forward and to both sides. If no loosening occurs, your child restraint should be secure.

If loosening does occur, try the following: If the buckle plate slides on the belt, turn the buckle plate over. If the buckle slides, turn the buckle. Refasten the vehicle lap belt. The release button should face **out** after twisting so that it is easy to reach in an emergency.

If the lap belt continues to loosen, the child restraint must be moved to another location in the vehicle. A locking clip will not correct this problem; see your vehicle owner's manual.

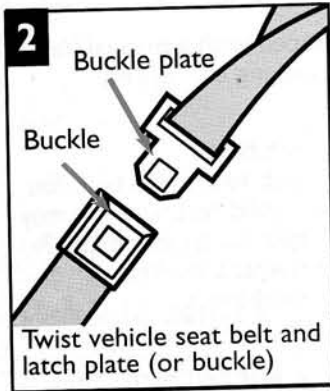

⚠ WARNING

Failure to check and adjust the manual lap belt as described above can result in serious injury or death.

Locking Clip

NOTE: Remove the locking clip when the seat belt is not being used with a child restraint. The locking clip is located on the back of the seat. A locking clip will not fix all types of seat belt problems.

Before you put your child restraint in the vehicle, buckle the lap/shoulder belt. Pull on the lap belt portion. If it loosens or slips, you must either use a locking clip to hold the seat belt tight or move the child restraint to another seating location.

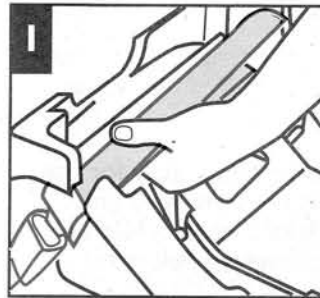

Thread both vehicle lap and shoulder belts through the belt path (as shown). Buckle. Pull up on shoulder belt until all slack is out and lap belt is tight. Grasp both vehicle belts together just behind the buckle plate and unbuckle.

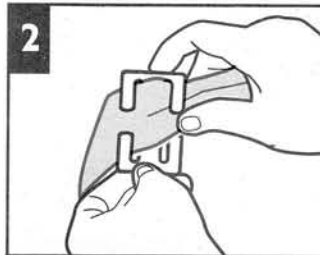

Thread both portions of the vehicle belt onto the locking clip.

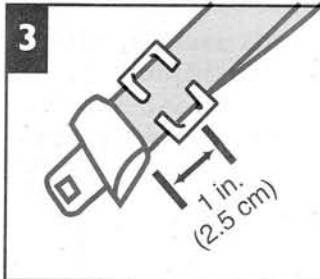

Position locking clip about 1 in. (2.5 cm) from vehicle belt's buckle plate.

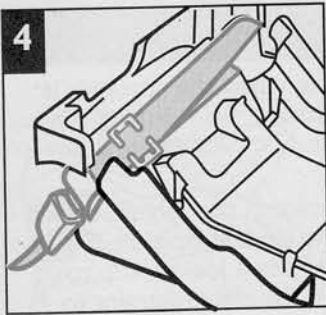

4
 Rebuckle belt. Lap belt portion should now be tight. If not, remove locking clip and repeat all steps.

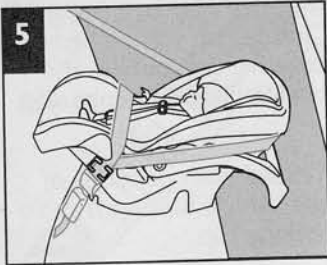

5
 Same steps apply for use on the child restraint. Make sure shoulder belt follows lap belt path.

Rear-Facing Use

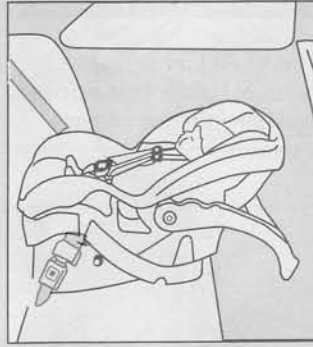

Lap/Shoulder Belt

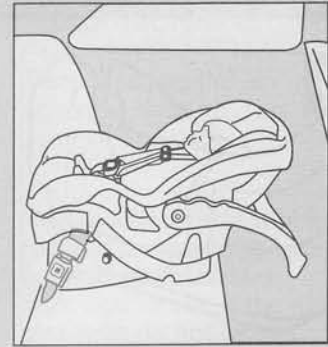

Lap Belt

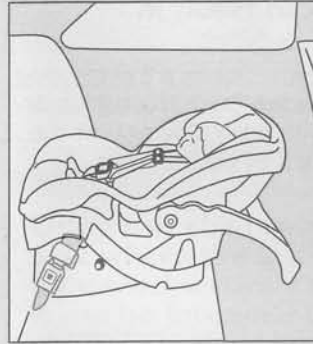

LATCH Belt

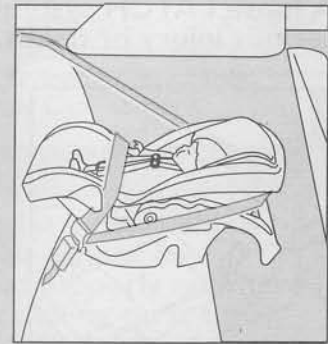

Lap/Shoulder Belt

Rear-Facing Use: 5-22 lbs (2.3-10 kg), 19-29" (48-74 cm).

⚠ WARNING:

Failure to place this child restraint facing the rear of the vehicle when the child is between 5-22 lbs (2.3-10 kg) can result in serious injury or death.



Placing a rear-facing child restraint in any seat equipped with an air bag can result in serious injury or death.

Rear-Facing Installation with Vehicle Belt - Using the Base:

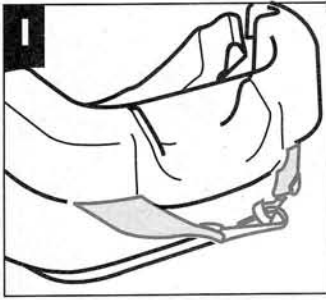

When LATCH is not available, fasten belt hooks together in front of base as shown.

⚠ WARNING:

A loose LATCH system can result in serious injury or death.

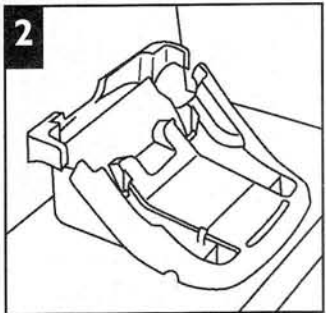

Place base in the back seat with taller side against the back of vehicle seat.



Thread the vehicle lap or lap/shoulder belt combination through belt path as shown. Buckle vehicle belt.

28



Push down firmly on the base and pull up on the belt to tighten. For a manual belt, refer to "Knowing Your Vehicle Belts" section. Pull up on shoulder strap to remove any slack.

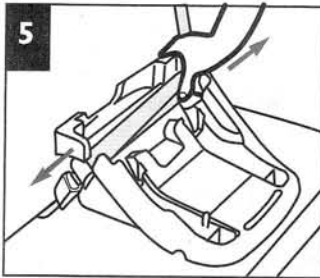

With weakest hand at belt path, tilt and push the base forward and back, and from side to side. If the seat belts do not loosen, your child restraint should be secure.

NOTE: Some "play" from front to back or about an inch from side to side is

acceptable. If it moves more, review "Knowing Your Vehicle Belts" and "The Locking Clip" sections.

⚠ WARNING

Using this child restraint in any vehicle seat where the lap belt cannot be tightened securely and properly or where it can be loosened by pulling on it can result in serious injury or death.

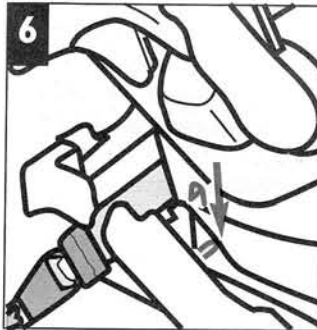

With child secured in child restraint, attach to base. Align notches in the front of shell with the bars on the base. Push down firmly to lock into place. You will hear a "click" when it is locked. Pull up to make sure it is locked into place.

29

continued on next page.

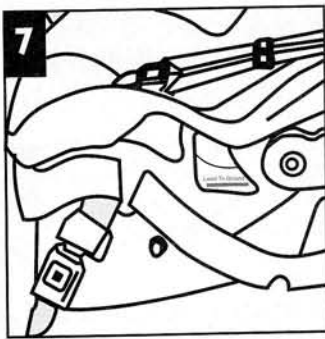

Make sure level line on side of shell is level to ground. Adjust base if needed.

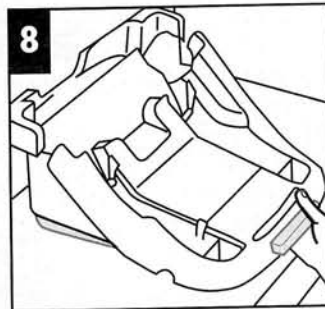

To Adjust Base (on select models):
Pull the adjustment lever and either lift or lower front of base.
If you have a non-adjustable base, refer to the "Troubleshooting" section.

⚠ WARNING

Failure to securely attach child restraint to base can result in serious injury or death.

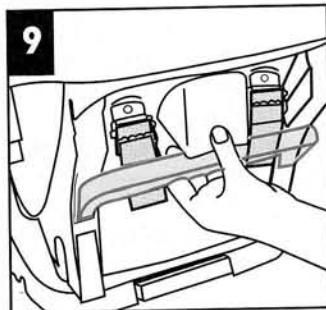

To Remove Seat from Base:
Pull up on red base release handle on back of child restraint and lift child restraint off base.

30

Rear-Facing Installation with Vehicle Belt - Without Base:

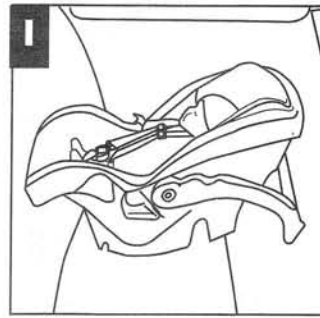

With child secured in child restraint, place rear-facing in the back seat. Make sure level line on side of shell is level to ground. Adjust child restraint if needed.

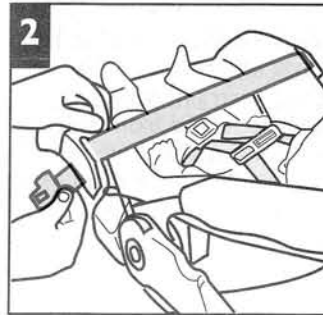

Thread the vehicle lap or lap/shoulder belt combination through shell's belt path as shown. Buckle vehicle belt.

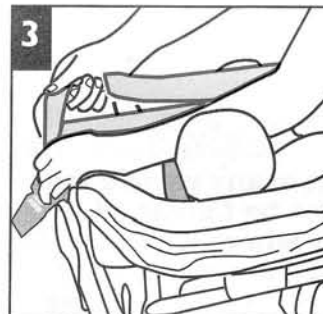

Lay your forearm across child restraint at the belt path while pulling up on belt to tighten. For a manual belt, refer to "Knowing Your Vehicle Belts" section. Pull on shoulder strap to remove any slack.

31

continued on next page.

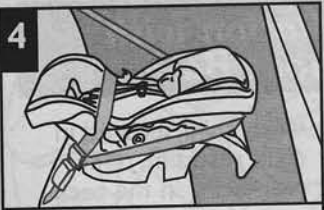

4 If your shoulder belt is long enough, you may secure it behind the seat shell by threading through both slots on back of shell.

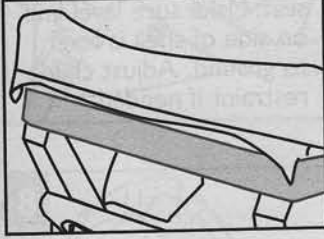

5 With weakest hand at belt path, tilt and push the child restraint forward and back, and from side to side. If the seat belts do not loosen, your child restraint should be secure.

NOTE: Some "play" from front to back or about an inch from side to side is acceptable. If it moves more, review "Knowing Your Vehicle Belts" and "The Locking Clip" sections.

⚠ WARNING

Using this child restraint in any vehicle seat where the lap belt cannot be tightened securely and properly or where it can be loosened by pulling on it can result in serious injury or death.

Rear-Facing Installation with LATCH and Base

NOTE: Do not use the LATCH system when using the vehicle lap or lap/shoulder belt.

LATCH is only equipped on the base. If desired, a LATCH kit or an additional base can be purchased for use on this child restraint. See replacement parts list.

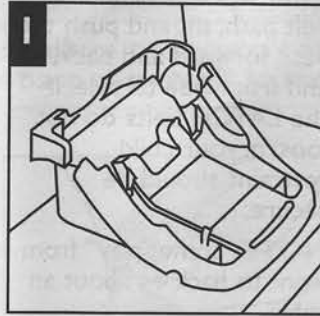

1 Place base in the back seat with taller side against the back of vehicle seat.

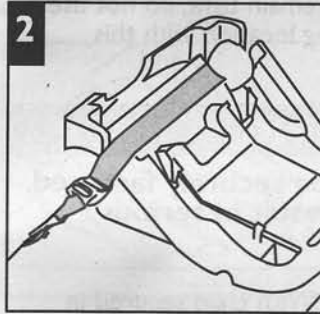

2 Thread the LATCH belt through belt path as shown.

NOTE: LATCH adjuster can be on either side, but belt should not be twisted.

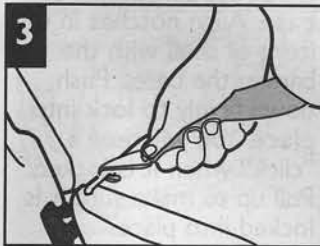

3 Fasten one LATCH belt hook to the anchor in the vehicle seat located in the vehicle seat bight. Repeat for other side of child restraint. See your vehicleowner's manual for more information.

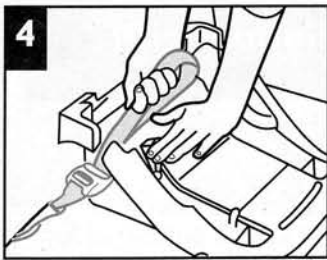

4 Push down firmly on the base and pull up on the loop to tighten belt.

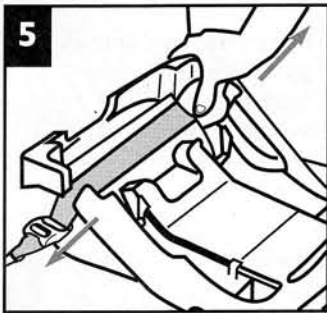

5 With weakest hand at belt path, tilt and push the base forward and back, and from side to side. If the LATCH belts do not loosen, your child restraint should be secure.

NOTE: Some "play" from front to back or about an inch from side to side is acceptable.

If the child restraint does not remain tight, do not use the child restraint in this seating location with this LATCH system.

⚠ WARNING

LATCH hooks MUST be securely fastened. Failure to do this can result in serious injury or death.

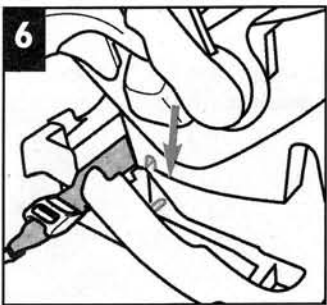

6 With child secured in child restraint, attach to base. Align notches in the front of shell with the bars in the base. Push down firmly to lock into place. You will hear a "click" when it is locked. Pull up to make sure it is locked into place.

34



7 Make sure level line on side of shell is level to ground. Adjust base if needed.

⚠ WARNING

Failure to securely attach child restraint to base can result in serious injury or death.



To release LATCH:
Push in on release button and pull LATCH adjuster away from child restraint to loosen. Unhook LATCH hooks.

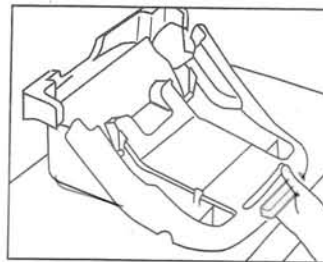

To Adjust Base:
Pull the adjustment lever and either lift or lower front of base. If you have a non-adjustable base, refer to the "Troubleshooting" section.

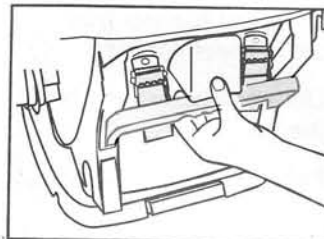

To Remove Seat From Base:
Pull up on red handle on back of child restraint and lift restraint off base.

35

Troubleshooting

✓1. If your child restraint is not held securely by the belt:

Press down firmly on the child restraint and remove all the slack in the belt. Make sure the belt buckle is not up against the child restraint where the belt cannot be tightened. Review Locking Clip section. If you cannot secure the child restraint tightly, move it to another seating location.

✓2. If the child restraint buckle sticks or you cannot get the straps tight enough around child:

DO NOT LUBRICATE. Check around buckle for dropped food, sticky spilled drinks, dirt, leaves, etc. Clean with warm water and/or remove object with tweezers. If you cannot get the harness to adjust and remain tight with the buckle securely locked, do not use the child restraint. **If the buckle plate will not lock securely, go to www.djgusa.com or call 1-800-544-1108 for assistance.**

✓3. If your harness twists or ropes:

Straighten the harness each time you put your child in the child restraint to help prevent twisting. Lock the buckle and tighten harness and it will be ready for next use.

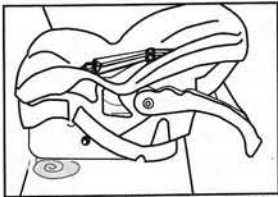

✓4. If your infant sits too upright in the rear-facing position:

If your vehicle seat slopes so much that your infant is sitting upright, you may place a rolled towel under the front of the

child restraint so that the level line on the side of shell is level (horizontal) to ground. Check often to be sure padding is still in place and the vehicle belt is tight.

⚠ WARNING

Using padding that tilts the child restraint farther back than the level-to-ground line can result in serious injury or death.

38

Warranty

Dorel Juvenile Group, Inc. (DJG) warrants this product to the original retail purchaser as follows:

This product is warranted against defective materials or workmanship for one year from the date of original purchase.

An original receipt is required to validate your warranty. DJG will, at its option, provide replacement parts or replace this product. DJG reserves the right to substitute if the part or model has been discontinued.

To make a claim under this warranty you may contact us at www.djgusa.com, fax us at 1-800-207-8182 twenty-four hours a day, write to DJG, Consumer Relations Department, P O Box 2609, Columbus, IN 47202-2609, or call 1-800-544-1108 from 7:00 a.m. to 6:00 p.m. EST Monday through Thursday and from 7:00 a.m. to 4:30 p.m. on Friday. **Proof of purchase is required and shipping charges are the responsibility of the consumer.**

Warranty Limitations:

This warranty does not include damages which arise from misuse or abuse of this product.

Limitation of Damages:

The warranty and remedies as set forth are exclusive and in lieu of all others, oral or written, expressed or implied. In no event will DJG or the dealer selling this product be liable to you for any damages, including incidental or consequential damages, arising out of the use or inability to use this product.

Limitation of warranties and other warranty terms and state law rights:

Any implied warranties, including implied warranties of the merchantability and fitness for a particular purpose, shall be limited to the duration and terms of the express written warranty. Some states do not allow limitations as to how long an implied warranty lasts or the exclusion or limitation of incidental or consequential damages, so the above limitations may not apply to you. This warranty gives you specific legal rights, and you may have other rights, which vary from state to state. Neither DJG nor the dealer selling this product authorized any person to create for it any other warranty, obligation, or liability in connection with this product.

PLEASE COMPLETE AND MAIL THE PRE-ADDRESSED OWNER REGISTRATION CARD WITHIN (30) DAYS OF PURCHASE TO EXPEDITE WARRANTY CLAIMS AND TO VERIFY THE ORIGINAL DATE OF PURCHASE.

39