

Ford 4R100

Performance Pack

Part No.

HP-4R100-01

Line Pressure Booster Kit

- Valve • Sleeve • Spring • O-Rings (2)

Line-to-Lube Pressure Regulator Valve†

TCC Control Plunger Valve Kit

- Valve • Sleeve

Front Lube/Drainback Valve Kit

- Front Lube/Drainback Valve Assembly
- Cup Plug

Line Pressure Modulator Plunger Valve Kit

- Valve • Sleeve • O-Ring

1-2, 2-3 & 3-4 Accumulator Control Valve Kits*

- Valves (3) • Retaining Clips (3)
- Spring Shims (12)

Heavy Duty Low/Reverse Modulator Sleeve Kit

- Modulator Sleeve • Orificed Valve
- Holding Valve • Spring

Performance Rated Accumulator Springs

- Non-Painted Springs (3)
- Red Springs (3) • Yellow Springs (2)
- Green Springs (2)

One-Piece Rear Case Bushing**

Center Support Gasket

Sure Lock® Overdrive Spiral Snap Ring

Intermediate & Direct Clutch Feed Seal Kit

- Intermediate Clutch Seal
- Intermediate Seal Adapter Tube
- Direct Clutch Seal
- Direct Seal Adapter Tube
- Springs (2)

High Radius Relief Valve

Rear Planet Endplay Shims (2)

†NOTE: This part is protected under patent number 6,826,908.

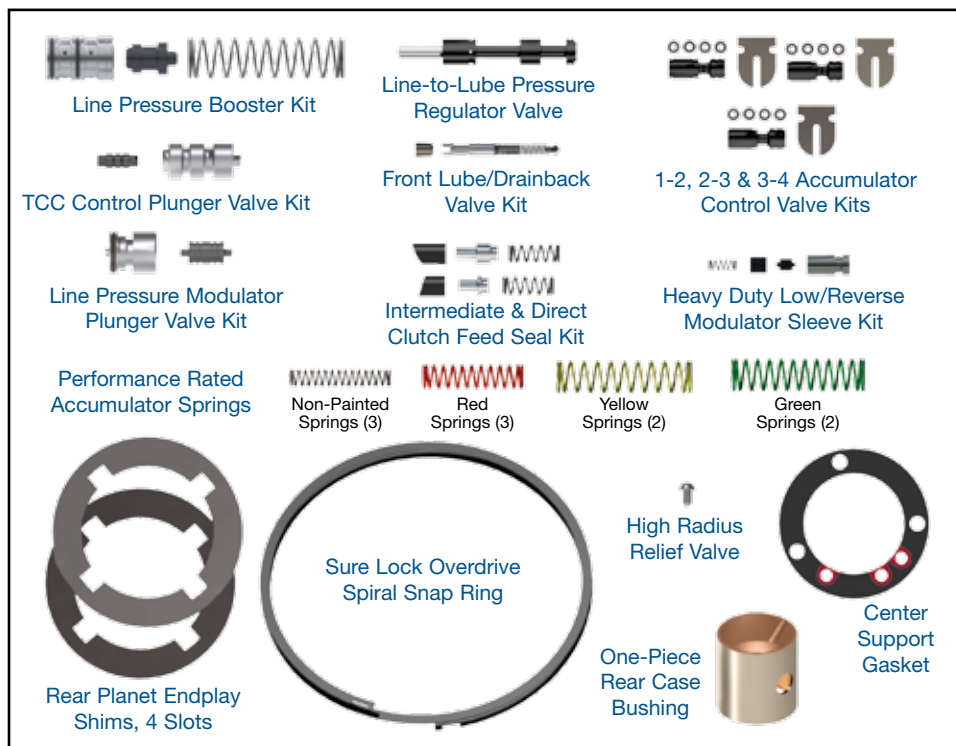

Torque Specifications

Pump to Stator & Case

18 to 23 ft-lb

Low Roller Clutch Race

25 ft-lb

3 Center Support Bolts

2, M12 bolts = 8 to 12 ft-lb

Valve Body & Solenoid Body Bolts & Nuts

80 to 100 in-lb

1, M10 bolt = 6 to 10 ft-lb

Clearance & Endplay

Front/Overdrive Unit Endplay

There is no OE adjustment for endplay. Check endplay to ensure assembly is correct. Typical endplay is .005" to .020".

Rear Endplay

Rear unit endplay can be checked through hole in center support; should be .032" to .055".

Pump Clearance

- Pump pocket: .001" to .002"
- Outer rotor to pump body: .004" max
- Lobe-to-lobe: .004" to .006"

Note: Excess lobe-to-lobe clearance = low pump volume and cooler flow, causing converter failure.

The following tools are highly recommended for installing this Performance Pack:

*Bore Sizing Tool

36948-12



**Bushing Installation Tool

T36008A



Clutch Clearance

Overdrive 3 Friction = .032" to .058" (selective snap rings)	Direct 4 Friction = .045" to .081" (selective snap rings)
Coast Clutch .030" to .050" (selective snap rings)	Forward .030" to .055" (selective snap rings)
Intermediate/2nd Gear Not adjustable	Low Reverse Not adjustable

To Reduce Delays in Reverse, tighten up these clutch packs to: • Coast: .020" • Direct: .010" to .020"
• Low/Reverse: .010" to .020"

Note: Alto[®] makes a kit for reverse delay with thicker steels so you can tighten up all three clutch packs.

Tech Tips

Cooler Return Line = Rear Line

PTO gear backlash does not need to be adjusted when using OE gasket. Replacement gasket is Ford #3C3Z-7223-AA or Muncie #13T37386.

There are two different length input speed sensors:

- With PTO gear use shorter sensor
- Without PTO gear use longer sensor

Always remove cooler bypass tube and fittings. Debris can plug fittings causing NO cooler flow. Cooler bypass tube has internal check valve that should open at 50–60 psi. Debris can cause bypass to stick open.

- Stuck Open = no flow through cooler and unit overheat.
- Stuck Closed = no cooler/lube when cold or if cooler is restricted.

There are two different styles of cooler bypass tubes, depending on model.

Pump Body

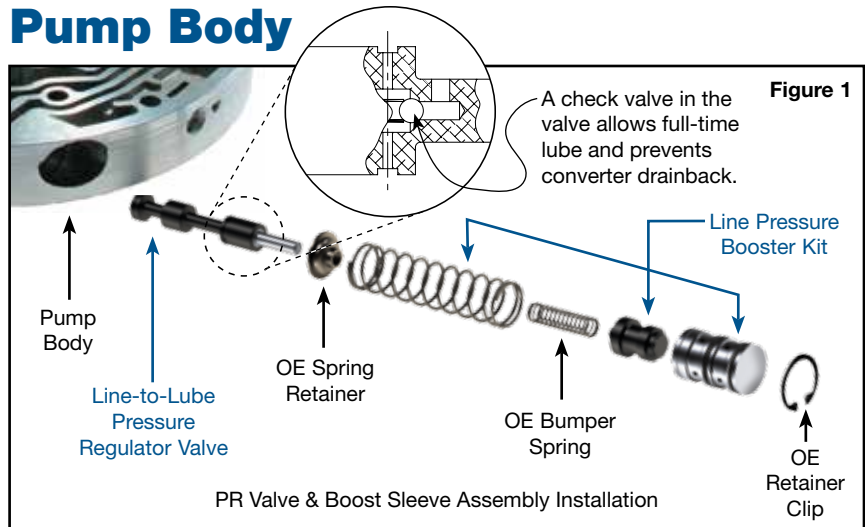

1. Line Pressure Booster Kit & Line-to-Lube Pressure Regulator Valve Installation

- Remove OE boost valve, pressure regulator springs, spring retainer and pressure regulator valve.
- If a line-to-lube orifice has been drilled into pump casting wall, it should be plugged (**Figure 2**).
- Install Sonnax line-to-lube pressure regulator valve with OE spring retainer, Sonnax line booster spring and OE bumper spring (**Figure 1**).
- Place Sonnax O-rings into grooves on Sonnax line booster sleeve. Roll sleeve on bench to size O-rings into grooves.
- Insert Sonnax boost valve into Sonnax boost sleeve with the nubbed end facing out.
- Lubricate boost sleeve assembly.
- Carefully insert Sonnax boost sleeve assembly into pump body, open end toward springs, just deep enough to reinstall OE retaining clip.
- After installation, perform a Wet Air Test (WAT) by checking for excessive leakage with pump halves torqued together. If cross-leakage is still evident after Sonnax O-ringed boost sleeve assembly is installed, the pump halves may be warped. Resurface and use Loctite[®] #518 gasket eliminator on the circuit from feed to the boost sleeve assembly.

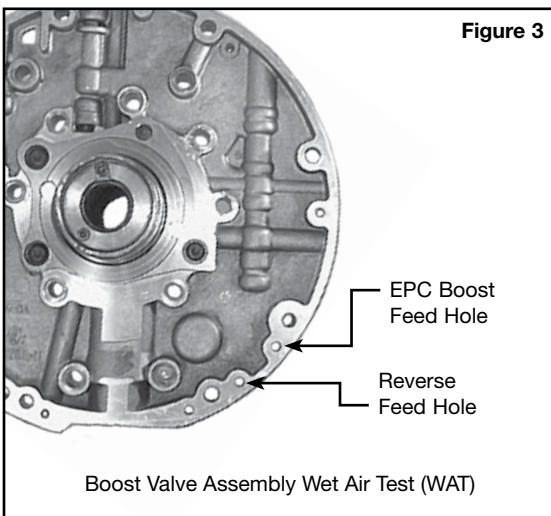
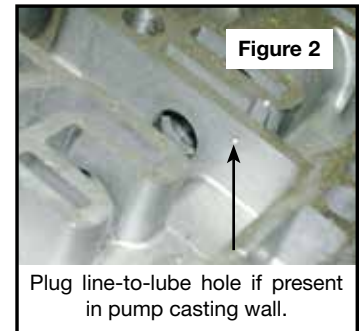

NOTE: To perform a WAT, put a small amount of oil into either the reverse boost feed hole or the EPC feed hole. Force low air pressure into the hole. There should be minimal leakage between the reverse boost/EPC feed circuit (**Figure 3**).

Pump Body (continued)

2. TCC Control Plunger Valve Kit Installation

- Remove OE retaining clip and set aside for reuse.
- Remove and discard OE TCC control sleeve and plunger valve.
- Install Sonnax TCC control plunger valve and sleeve (**Figure 4**).
- Reinstall OE retainer.

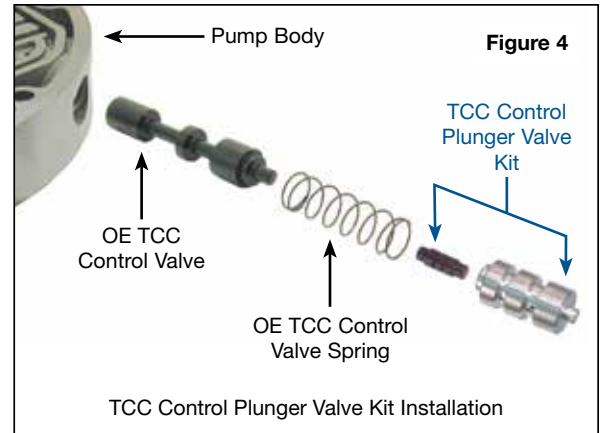

Stator Support

Front Lube/Drainback Valve Kit Installation

- Thread a small screw into OE orifice cup plug hole.
- Remove and discard OE orifice cup plug (the screw is only used for removing OE cup plug).
- Remove OE front lube/drainback valve, spring and ball seat.
NOTE: Ensure OE ball seat is removed, as it may be separated from spring.
- Clean and inspect bore, ensuring it is clear of any debris.
- Place Sonnax front lube/drainback valve assembly into cleaned bore (**Figure 5**).
- Install Sonnax orifice cup plug into bore. Cup plug should be .030" to .060" below flush.
- Lightly stake bore to prevent orifice cup plug from backing out of bore.

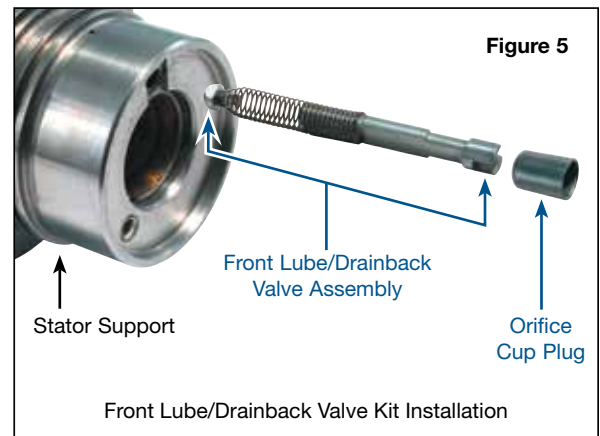

Accumulator Body

This 4R100 Performance Pack will increase shift firmness due to a larger-diameter line pressure boost valve and stiffer accumulator springs. Assemble without shims and road-test vehicle. For extreme performance applications, shims can be added to increase firmness of a specific shift. Shift firmness can also be increased by making a "V" notch in the accumulator body deeper using a .120" drill bit, or by drilling the appropriate accumulator piston feed hole in the separator plate to .063".

1. 1-2, 2-3 & 3-4 Accumulator Control Valve & Performance Rated Accumulator Springs Installation

- Remove all components from accumulator control bores. Discard OE accumulator springs and control valves. Keep the OE valve spring, retaining clip, accumulator piston, end plug and end plug clip for reuse.
NOTE: If OE control valve was stuck or if Sonnax sticks, use Sonnax bore sizing tool **36948-12** (not included in this Performance Pack) to smooth the accumulator control valve bore (**Figure 6**). Instructions for this procedure are on page 4.

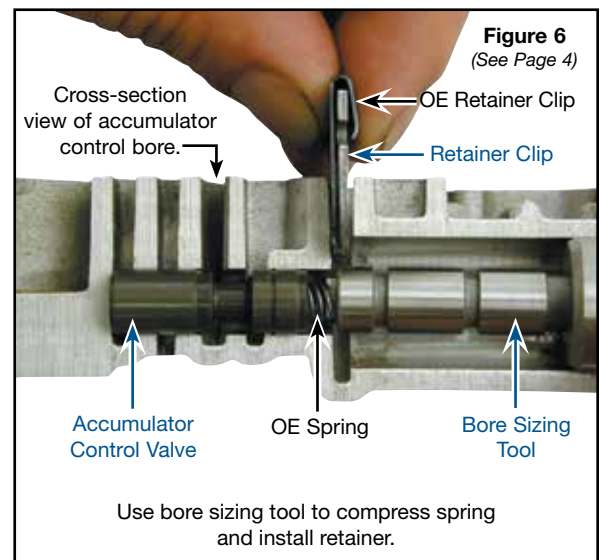

Accumulator Body (continued)

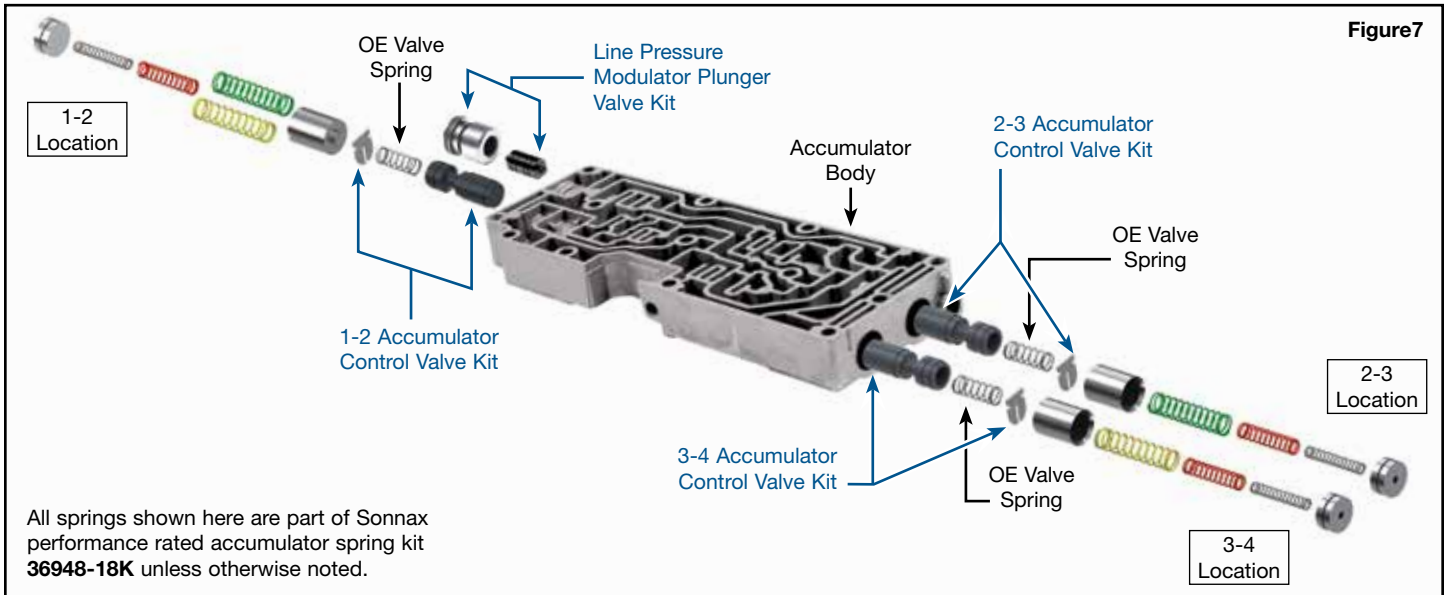

1. 1-2, 2-3 & 3-4 Accumulator Control Valve & Performance Rated Accumulator Spring Kits Installation (continued)

- Install Sonnax accumulator control valves. Recommend assembling **WITHOUT** shims and road testing. For extreme performance applications, shims can be added to spring pocket in the accumulator valve to increase firmness of a specific shift. The more shims used, the firmer the shift.
- Place OE accumulator control valve spring into pocket on Sonnax valve and install both the OE and Sonnax retainer clips (**Figure 6, page 3**). Sonnax bore sizing tool **36948-12** (not included in this Performance Pack) can be used to compress this spring.
- Install OE accumulator piston and Sonnax performance rated accumulator springs.



- **1-2 Location:** If OE spring is BLUE (**Figure 7**), install one (large) YELLOW Sonnax spring, one (medium) red Sonnax spring and one (small) unpainted Sonnax spring into OE accumulator piston pocket. If OE spring is WHITE or anything other than BLUE, install one (large) GREEN Sonnax spring, one (medium) red Sonnax spring and one (small) unpainted Sonnax spring into OE accumulator piston pocket.

- **2-3 Location:** Install one (large) GREEN Sonnax spring, one (medium) red Sonnax spring and one (small) unpainted Sonnax spring into OE accumulator piston pocket.
- **3-4 Location:** Install one (large) YELLOW Sonnax spring, one (medium) red Sonnax spring and one (small) unpainted Sonnax spring into OE accumulator piston pocket.

e. Reinstall OE end plug and retainer.

2. 1-2, 2-3 & 3-4 Accumulator Control Bore Sizing Instructions

NOTE: Sonnax bore sizing tool **36948-12** is highly recommended, but not included in this

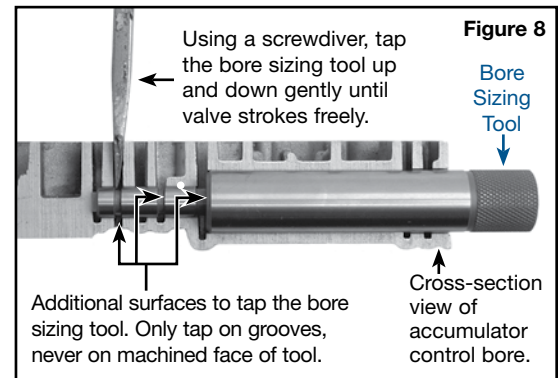

4R100 Performance Pack. Bore sizing tool is used to properly resize and smooth the accumulator control bore to eliminate valve hang-ups and sticking.

- With all components removed from bore, insert Sonnax bore sizing tool into accumulator control bore until tool bottoms out.
- Remove bore sizing tool and verify the Sonnax accumulator control valve moves freely within the bore.
- If valve does not move freely, reinstall bore sizing tool and tap tool up and down using a hammer and screwdriver (**Figure 8**). Repeat process until valve strokes freely.

Accumulator Body (continued)

3. Line Pressure Modulator Plunger Valve Kit

Installation See photo overview (Figure 7).

- Remove and save OE retaining clip.
- Remove and discard OE line pressure modulator sleeve and plunger valve.
- Insert Sonnax plunger valve into Sonnax sleeve.
- Place Sonnax O-ring into groove on outside diameter of Sonnax sleeve.
- Place nub on the end of Sonnax plunger valve through hole in OE spring assembly disc (Figure 9). Push sleeve/spring assembly into accumulator body, open end toward the springs, just deep enough to reinstall OE retaining clip.

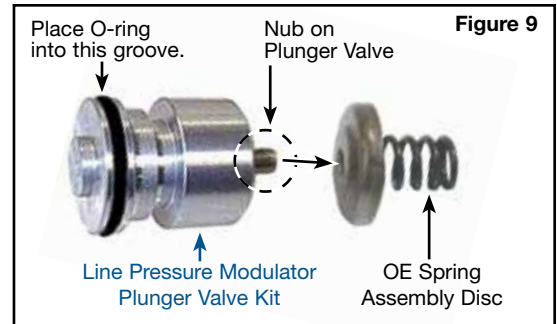

Valve Body

1. Heavy Duty Low/Reverse Modulator Sleeve Kit Installation (Figure 10)

- Remove OE retainer and set aside for reuse.
- Remove and discard OE sleeve, plunger valve, holding valve and spring.
- Install Sonnax spring, holding valve, plunger valve and sleeve. Ensure spring seats in holding valve spring pocket.
- Secure with OE retainer.

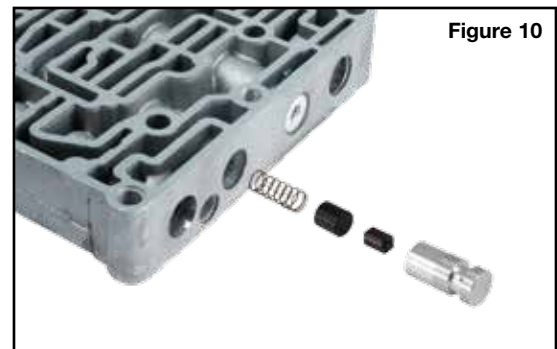

Reassembly Parts (Figures 11, 12 & 13)

1. One-Piece Rear Case Bushing Installation

- Remove worn or damaged OE bushings from transmission case.
- Remove any ridge or case material with a hone if the bore I.D. is irregular.
- Apply Loctite® 609 sealant to case bore.
- Align lubrication hole of Sonnax bushing with the hole in transmission case.
- It is important to use Sonnax bushing installation tool T36008A (not included in this Performance Pack) to prevent deformation of the long, thin-walled bushing. The bushing installation tool shoulder is designed to seat bushing at the proper depth.
- After installing Sonnax bushing, confirm lubrication holes are properly lined up and that correct clearance has been maintained between bushing and output shaft.

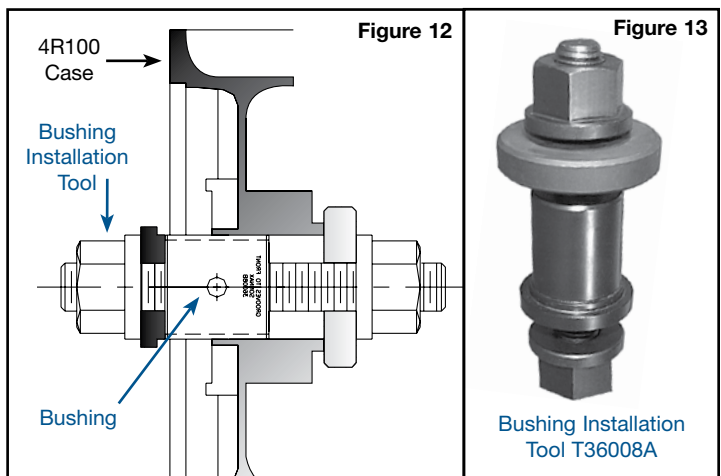
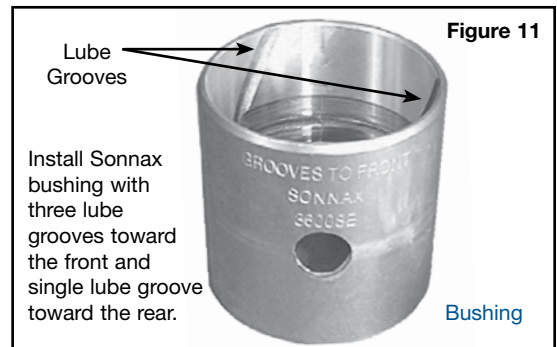

Reassembly Parts (continued)

2. Center Support Gasket Installation (Figure 14)

- Remove any burrs and break sharp edges on the aluminum center support contact surface.
- Using a medium-grit oil stone, smooth mating hub surface.
- Clean both parts, including tapped holes, with solvent.
- Lightly coat gasket surface with assembly lube and place in center support counter-bore with beaded gasket surface against center support.
- Align gasket holes with center support and set hub in place.
- Apply Loctite® 242 Threadlocker on the three M6 mounting screws, following Loctite® instructions.
- Install screws and progressively torque to 75–85 in-lb initially, then torque to 100–120 in-lb.

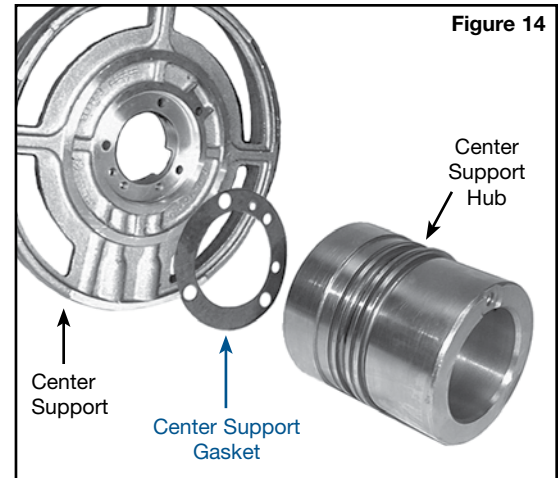

3. Sure Lock Overdrive Spiral Snap Ring Installation (Figure 15)



WARNING: Ensure snap ring is installed correctly. Failure to install correctly may result in unit failure.

- Using a spring compressor, compress OE overdrive return spring retaining ring.
- Remove and discard OE overdrive return spring retaining ring.
- Install one end of the Sonnax Sure Lock overdrive spiral snap ring into OE retaining ring groove.
- With Sonnax snap ring end installed in groove, work the rest of the ring into groove one wrap at a time (Figure 16).
- After Sonnax snap ring is fully installed, ensure the locking tabs are engaged with the cutouts in retaining ring as shown. It may be necessary to bend the locking tabs up to get a secure lock (Figure 17). Do NOT bend the cut-out portions.

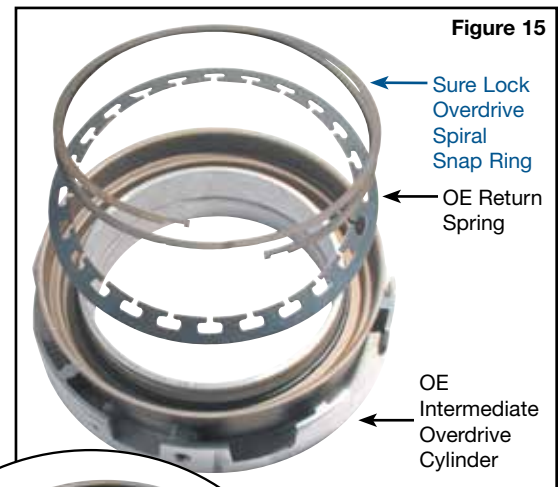

4. Rear Planet Endplay Shim Installation (Figure 18)

When visible spline or driveline wear is evident, it is beneficial to install .010" shim(s) during lower unit assembly. The Sonnax rear planet endplay shims should be installed under the four-tanged OE thrust washer, located between the reverse planetary carrier and input shell. When final assembly is completed, total endplay should be inspected with an "H" gauge, depth micrometer or dial caliper. The OE endplay specification is .075". The recommended endplay is .040" or less. This shim does not reduce output shaft free play.



NOTE: Sonnax rear planet endplay shims will not fit applications with six-pinion carriers.

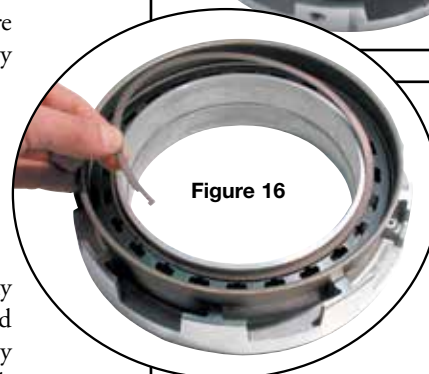

Figure 16

The Sonnax Sure Lock features tabs that lock the snap ring in groove.

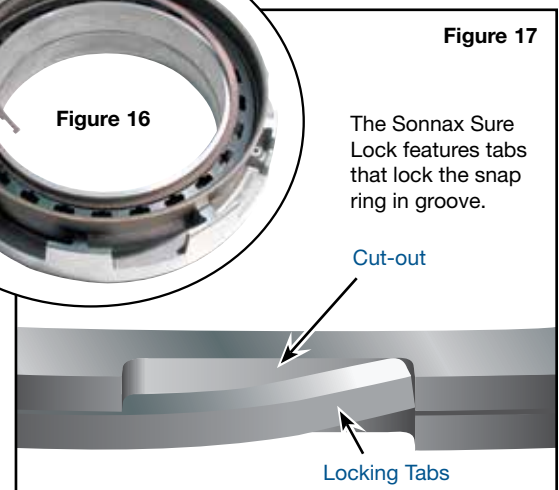

Figure 17

Reassembly Parts (continued)

5. Intermediate & Direct Clutch Feed Seal Kit

Installation (Figure 19)



IMPORTANT NOTE: These intermediate and direct clutch feed seals are installed after internal parts are assembled and before valve body is installed.

Intermediate Clutch

- Coat rubber seal with assembly lube.
- Align locator guide nub with slot in case and insert Sonnax rubber seal into the intermediate feed port (Figure 20).
- Install Sonnax aluminum seal adapter tube followed by Sonnax spring.

Direct Clutch

- Due to casting variations on late 4R100 units, the alignment nub *may* need to be cut off the direct clutch seal.
 - If distance from valve body gasket surface to the cast passage (Figure 21) is more than .625", install Sonnax seal as-is.
 - If distance from valve body gasket surface to the cast passage (Figure 21) is less than .625", cut nub off the side of the direct clutch seal (Figure 22).
- Coat Sonnax rubber seal with assembly lube.
- Align locator guide nub with slot in case and insert rubber seal, flush with inside of case.
- Install Sonnax aluminum seal adapter tube, then Sonnax spring.

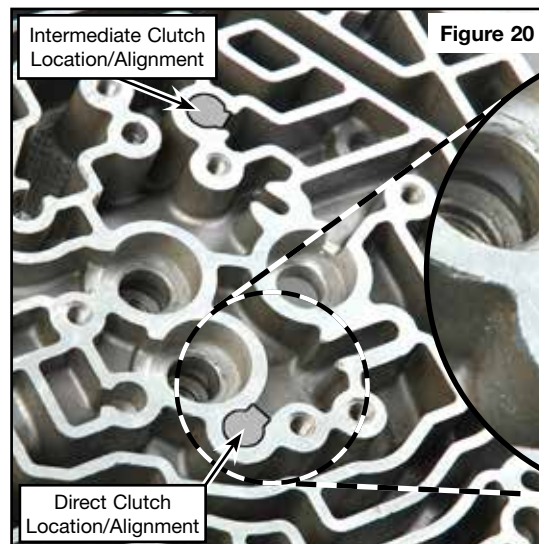
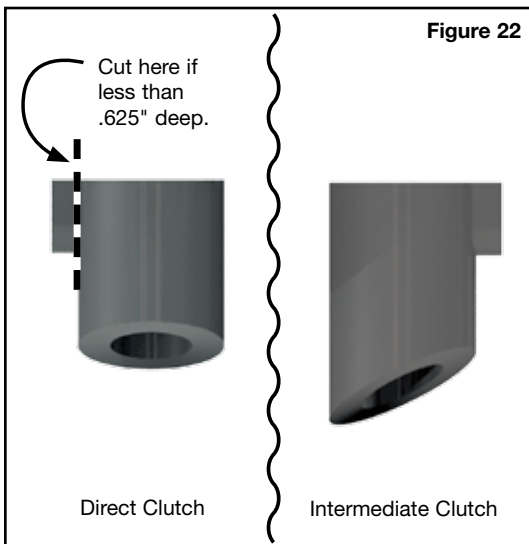
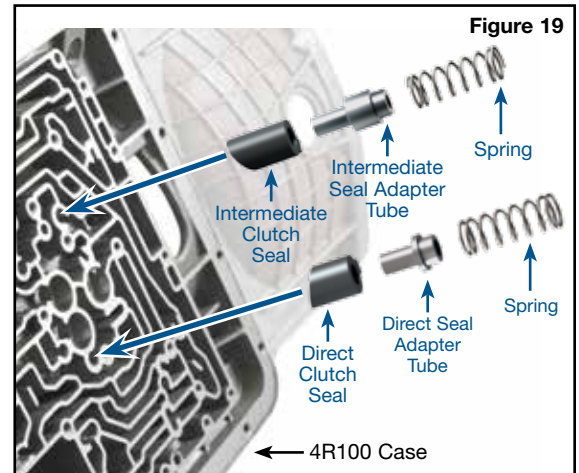
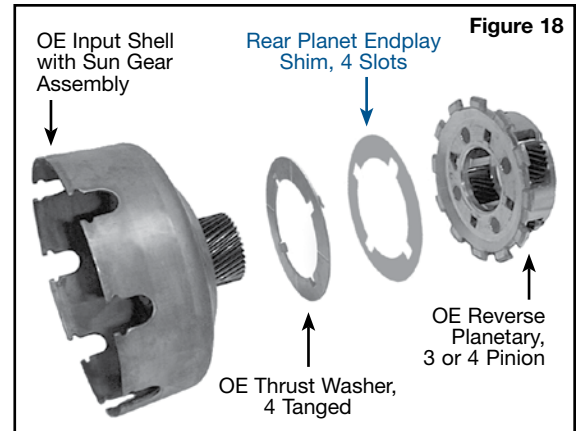

Figure 20

Intermediate Clutch Location/Alignment

Direct Clutch Location/Alignment

4R100 Case

Measure Direct Clutch Depth

Figure 21

Measure Direct Clutch Depth

6. High Radius Relief Valve Installation (Figure 23)

- Remove OE EPC relief “blow-off” checkball from 4R100 case.
- Replace with improved, stemmed Sonnax high radius relief valve.

