

**APPLYING NEGATIVE SEQUENCE
TO MUTUALLY COUPLED TRANSMISSION LINES –
A UTILITY PROSPECTIVE**

GIROLAMO ROSSELLI, P.E.
San Diego Gas & Electric
San Diego, California, U.S.A.

69th Annual
Georgia Tech Protective Relaying Conference
Atlanta, Georgia
April 29 to May 1st, 2015

BACKGROUND INFORMATION

- On December 23, 2013, San Diego Gas & Electric experienced a misoperation of a 69 kV transmission line, which was mutually coupled to a 230 kV line.
- The 230 kV line relays cleared the fault properly.
- A 69 kV two-terminal line was installed on the same tower, which also operated on both ends of the line at the same time as the 230 kV line.
- The 69 kV line targeted an instantaneous directional ground element on Station A and TTR to the other station.

BACKGROUND INFORMATION

- The line reclosed by relay action and held closed, implying no permanent fault.
- This line had misoperated before on zero sequence mutual coupling, and steps were taken early on to desensitize the residual/ground elements.
- What caused this misoperation?

TL-AB RELAYS

- The line relays at Station A are older type SEL-100 series without much flexibility in isolating some of the component elements such as I2.
- The line relays at Station B are newer type SEL-300 series with much more flexibility in isolating some of the component elements.
- What can be done to increase security and keep the same sensitivity at Stations A & B using the existing relays?

PARTIAL SYSTEM DIAGRAM

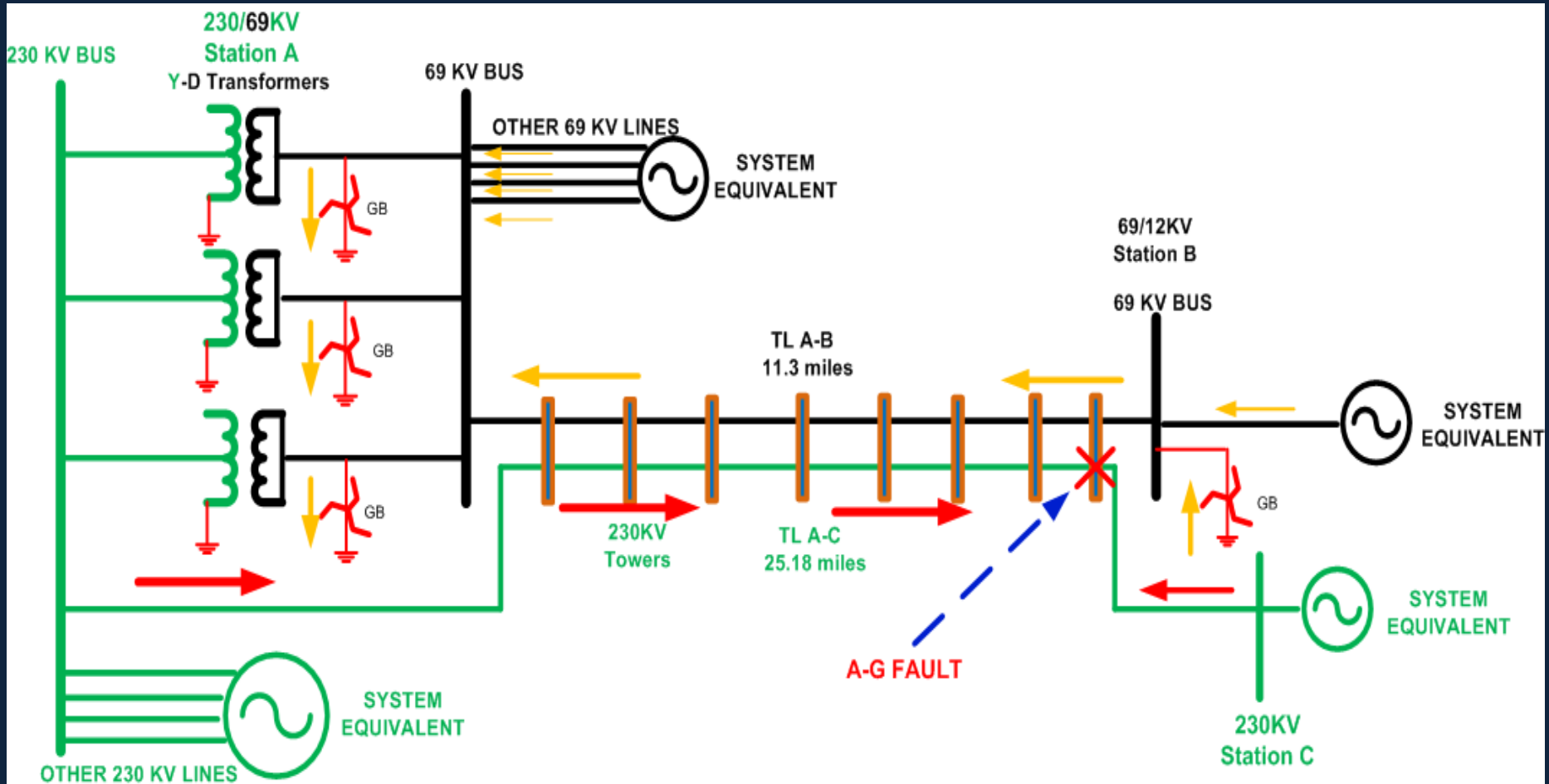

LINE CONSTRUCTION

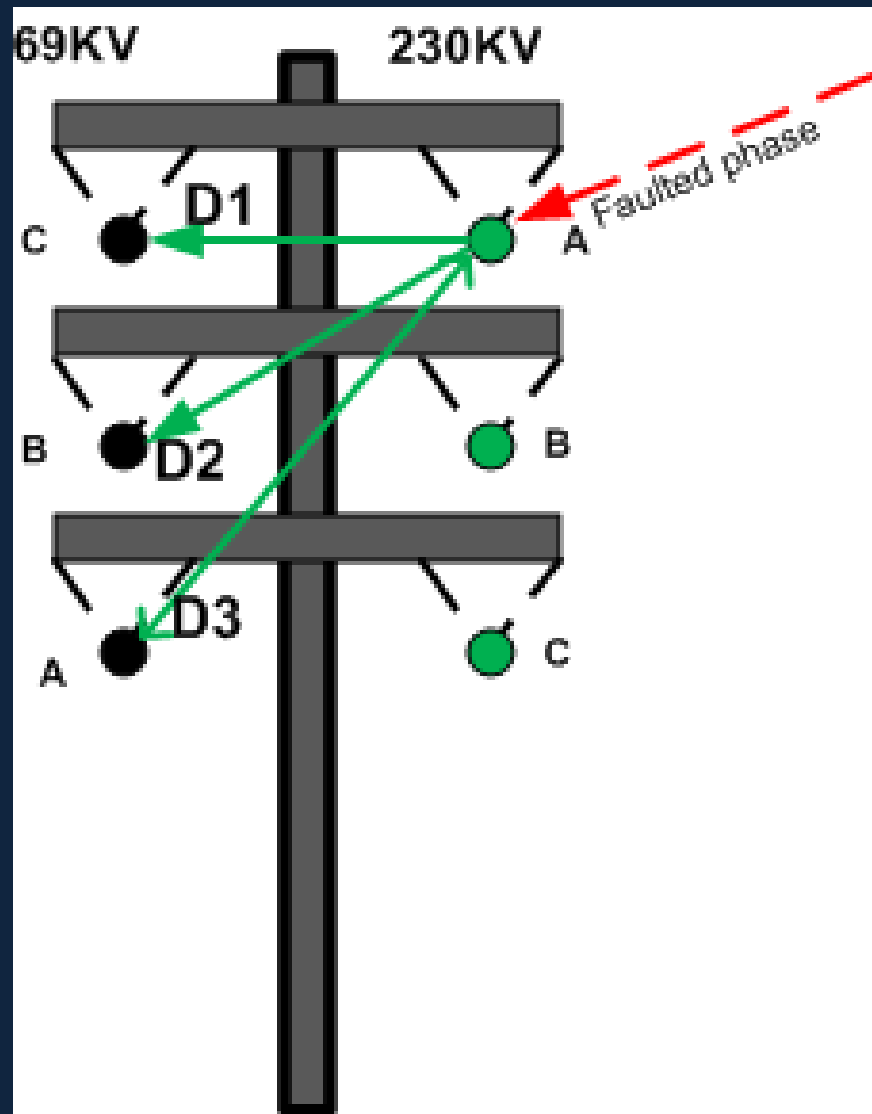

SUBSTATION A LINE RELAY EVENT

Event Time: 12/23/2013 12:21:39.704000

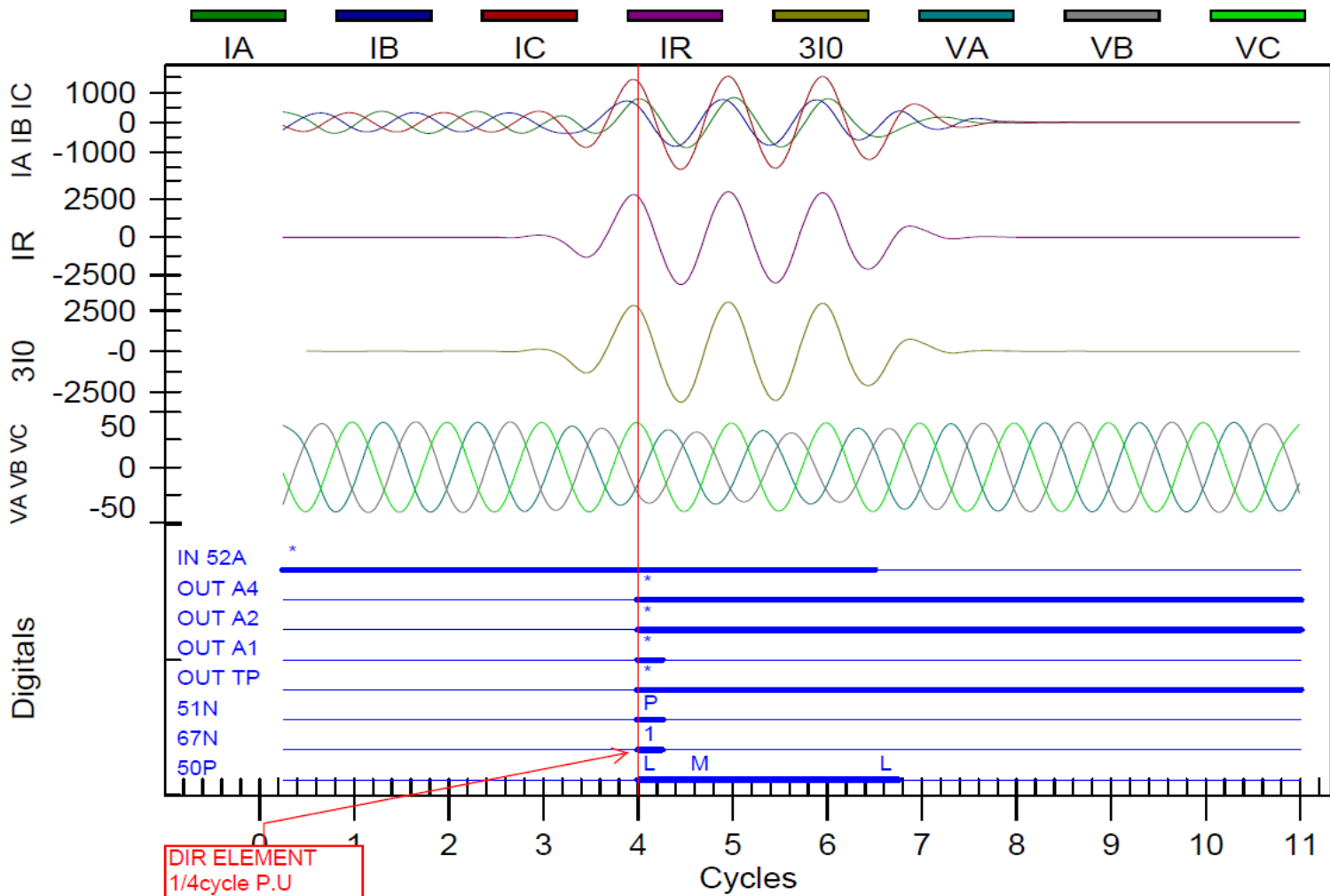

SUBSTATION A LINE RELAY EVENT PHASOR AND SEQUENCE DIAGRAM

Phasor Elements

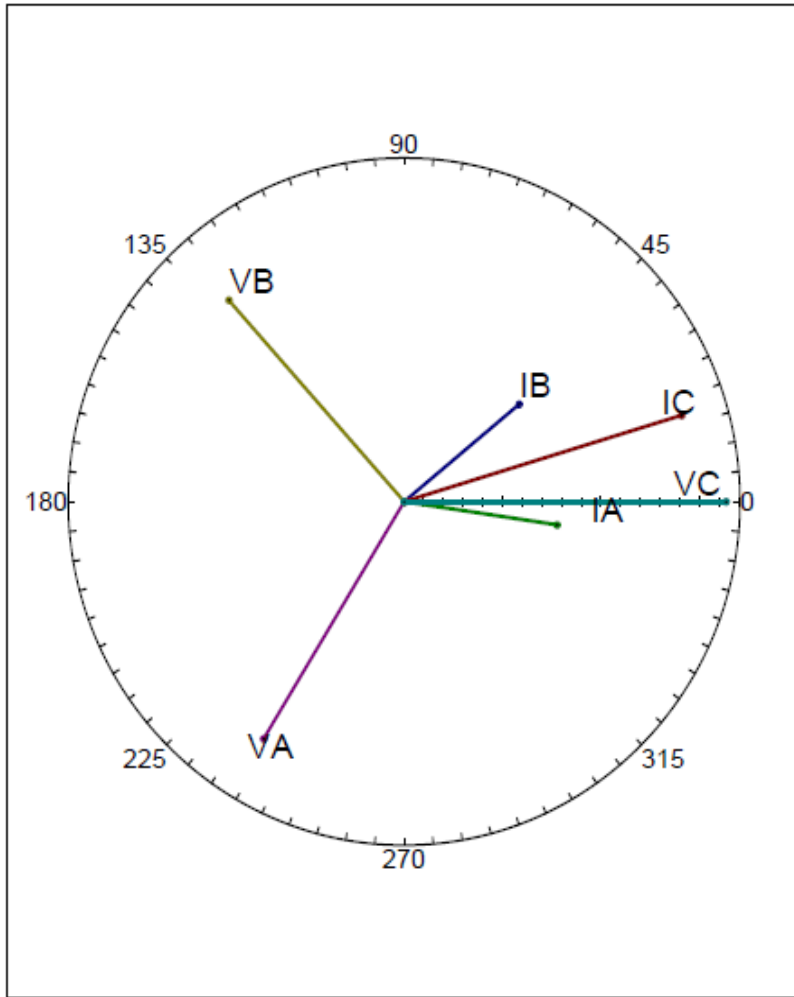

Sequence Elements

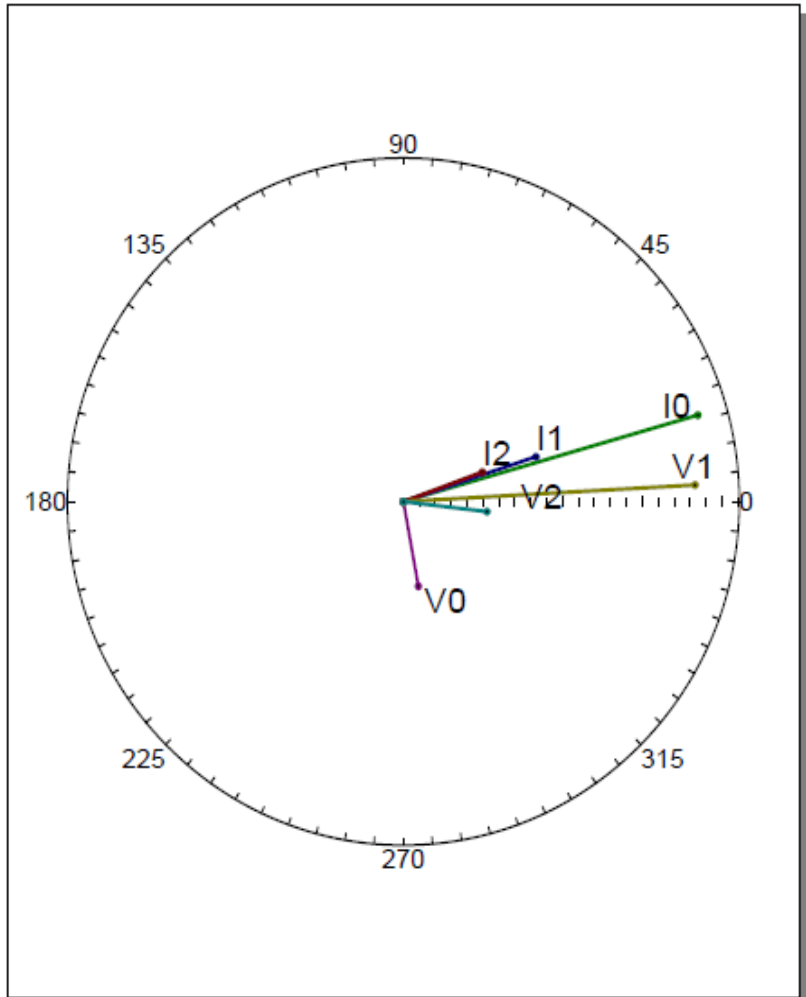

SUBSTATION A LINE RELAY EVENT SEQUENCE MAGNITUDE AND ANGLES

Cycles: 4.250000

Reference Phase: C

<u>Channel</u>	<u>Mag</u>	<u>Angle</u>	<u>Scale</u>	<u>Show</u>	<u>Ref</u>
IPOL	1582.6	10.1	1	0	
IR	2889.3	16.1	1	0	
IA	786.1	351.5	1	1	
IB	758.0	39.6	1	1	
IC	1473.2	16.9	1	1	
VA	34.0	238.8	1	1	
VB	33.0	131.7	1	1	
VC	40.4	0.0	1	1	1
I0	961.1	16.0	1	1	
I1	437.9	18.3	1	1	
I2	74.6	20.1	1	1	
V0	1.5	280.2	1	1	
V1	35.6	3.2	1	1	
V2	4.6	353.4	1	1	

SOLUTION

CHANGES MADE TO THE SEL-121H AND SEL-167 RELAYS AT STATION A

- Switch elements 50N1 with 50N3 (50N3 can be time delayed).
- Make setting changes to 50N3 more sensitive with 1 cycle delay.
- Make setting changes to 50N1 less sensitive and cover close in-line fault instantaneously.

**OUTPUT = 50N3T * TDPU 1 CYCLE [with IR=FOR (67NT)]
+ 50N1 + OTHER TRIP ELEMENTS**

CHANGES MADE TO THE SEL-300 SERIES RELAYS AT STATION B

- Supervise the 50N1 element with the negative sequence overcurrent element I2 since zero sequence mutual coupling does not have I2 (theoretically)

OUTPUT = 67N1T*67Q1T + OTHER TRIP ELEMENTS

CHANGES MADE TO SEL-300 SERIES RELAYS AT STATION B

FOR MUTUAL COUPLING CONDITION

50N1T * 50Q1T

1

*

0



OUTPUT = 0 NO TRIP CONDITION

FOR IN-LINE FAULT CONDITION

50N1T * 50Q1T

1

*

1



OUTPUT = 1 TRIP CONDITION

BENEFIT

- ❑ Increased Security
 - ❑ Speed is not compromised
 - ❑ Same Selectivity
 - ❑ Increased Sensitivity
 - ❑ Simplicity- No Complication
- Immune to Mutual Coupling Condition

BEST OF ALL NO VIOLATION OF THE PRINCIPLE OF 5-S's

TRIP OUTPUT = $67N1T * 67Q1T + \text{Other Trip Conditions}$

PQ TEACHING TOY SIMULATOR

The PQ Teaching Toy Link can be found at the following site:

<http://www.powerstandards.com/PQTeachingToyIndex.php>

PQ TEACHING TOY SIMULATOR

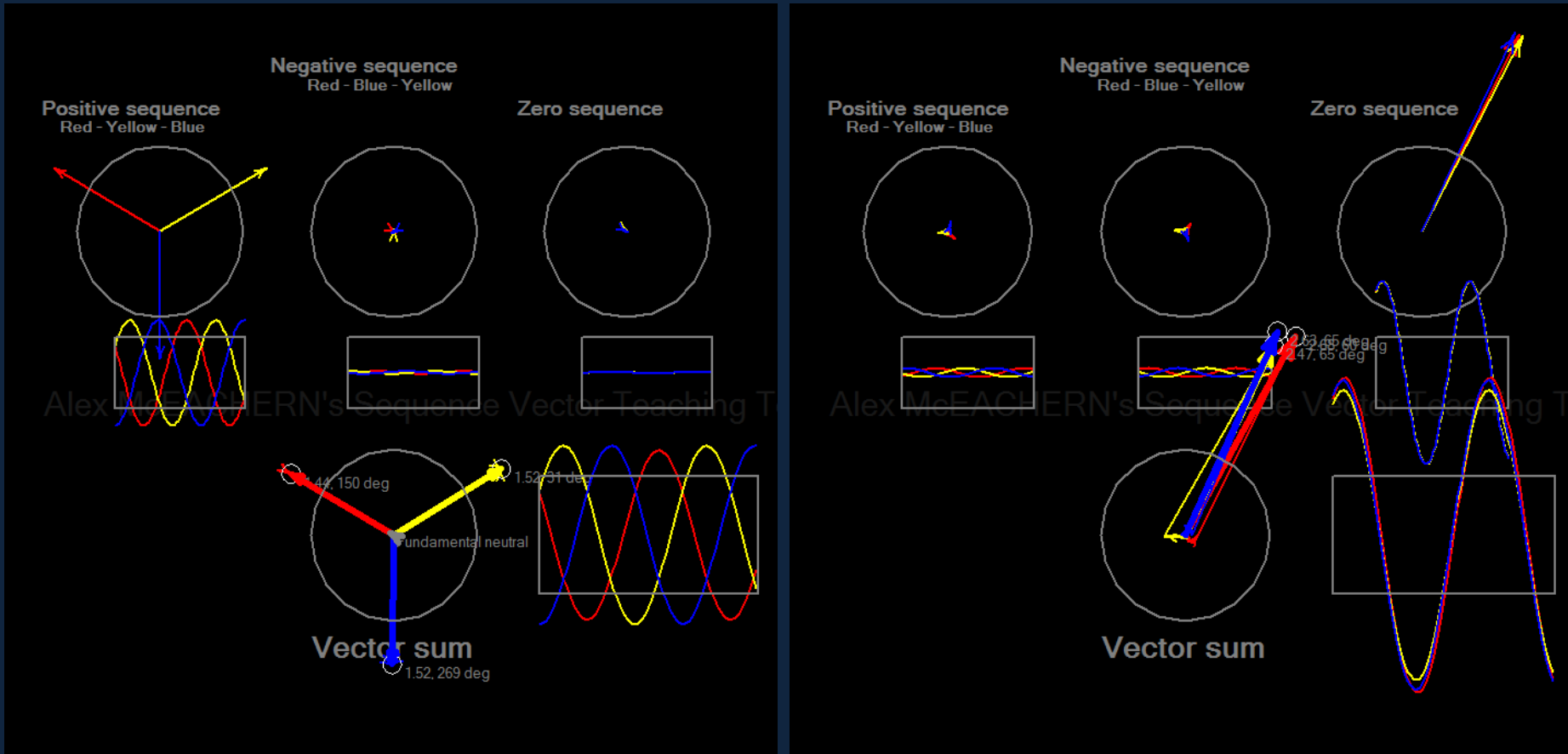

BRINGING THE 3-PHASES TOGETHER WILL SHOW HOW YOU CAN SIMULATE MUTUAL COUPLING

EVENT SIMULATION USING PQ TEACHING TOY

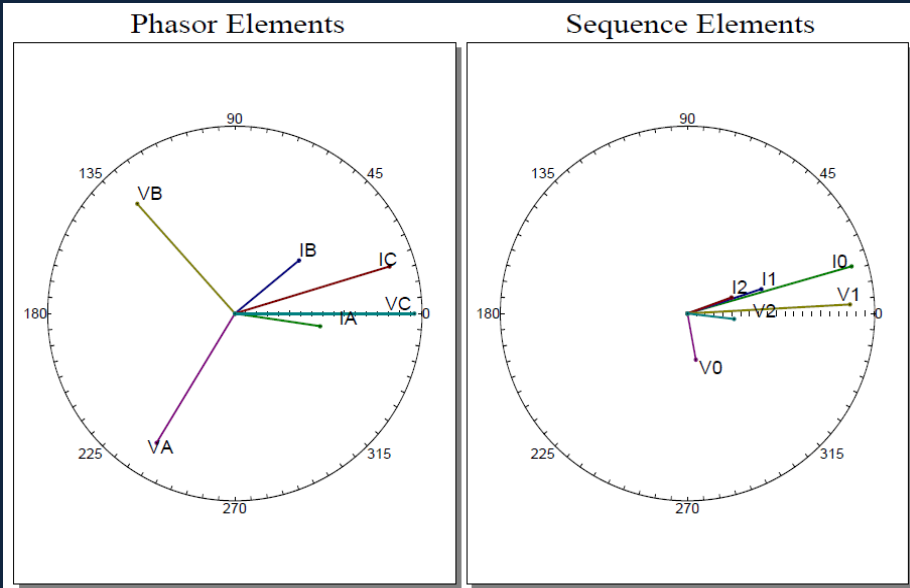

Event Time: 12/23/2013 12:21:39.704000

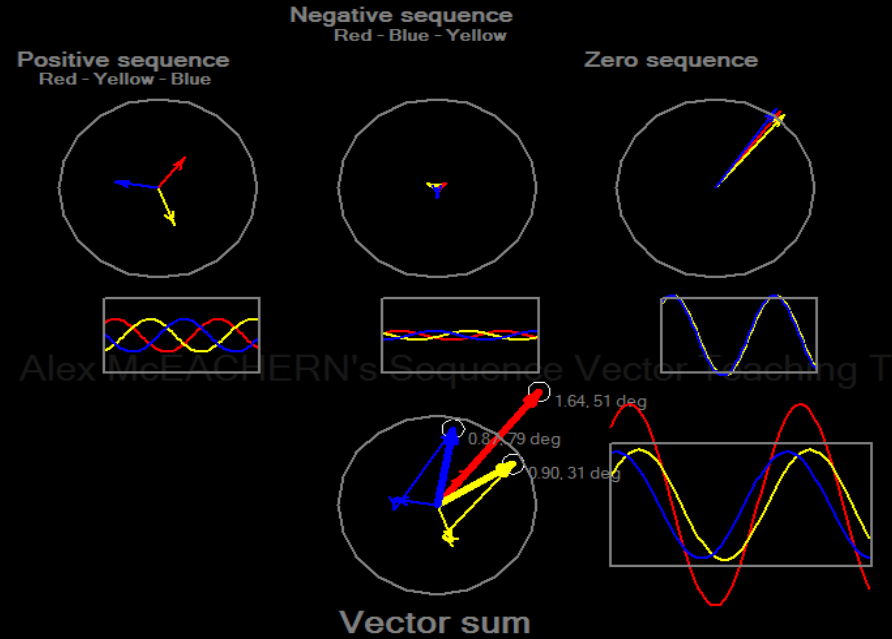
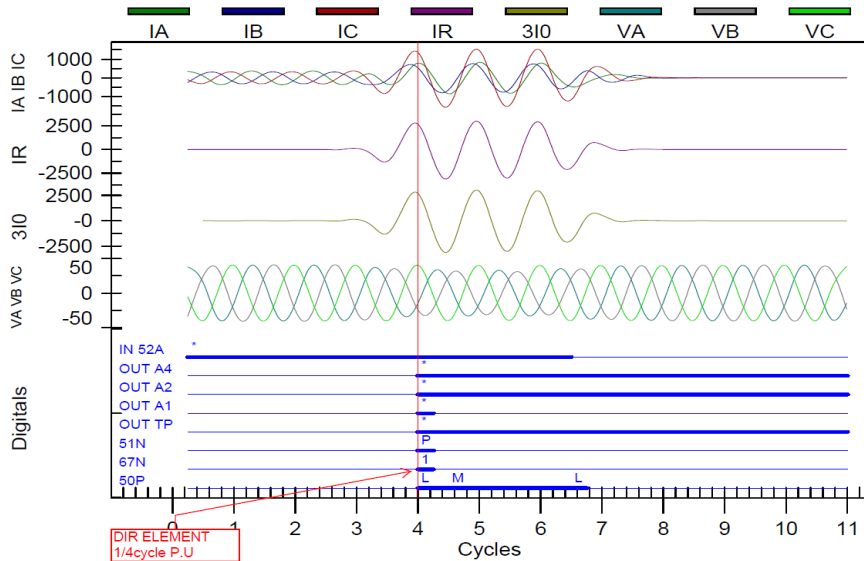

CONCLUSIONS

Hopefully, this paper will provide new insights to the relay engineer so that better relay settings can be set for the transmission system, thus enhancing the security, sensitivity, and to provide the ability to maintain coordination and avoid any future disturbances due to zero sequence mutual coupling.

ANY QUESTIONS ?