

30" ELITE SERIES GRILL



Product Shown: E30BQR with optional cart



Feature Shown: 50 Watt Halogen Grill Light with Fan Cooled Rotisserie Motor. A perfect compliment for your evening grilling!



Feature Shown: Large Grilling area with W radiants that prevent flare-ups from ruining your meal!

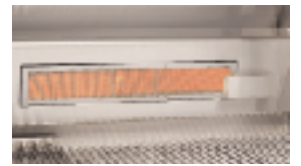

Feature Shown: Infra-Red Rotisserie burner. Rotis your favorite meat or poultry for the taste you and your guest will savor!

Product Features

- 1 (2) 28,000 BTU Stainless Steel burners
- 1 (1) 15,000 BTU Ceramic Infra-red rotisserie burner
- 1 Stainless Steel W radiants
- 1 9-Volt Battery Ignition
- 1 Heavy duty Stainless Steel Grill Grates
- 1 Removable warming rack
- 1 Heavy duty 50 pound capacity rotis motor with halogen light.
- 1 Stainless Steel easy slide drip pan
- 1 Seamless welded grill lid
- 1 Heavy duty metal knobs
- 1 **775** square inches of grilling area

Optional Cart Features

- 1 4 Sided enclosed cart
- 1 (2) Large 21.50" X 16.5" folding side shelves
- 1 (2) Rubber mounted wheels and (2) rubber mounted caster wheels, (1) locking
- 1 (2) large lined access doors
- 1 Fully Assembled

Models Available

- 1 E30BQRL - ELITE 30" BQ with ROTIS- LP
- 1 E30BQRN - ELITE 30" BQ with ROTIS- NAT

Recommended Accessories

- 1 Stainless Steel Grill Cart (E30C)
- 1 Heavy Duty vinyl cover
- 1 Removable Maple cutting boards (EMCB)
- 1 Removable Corian cutting boards (ECCB)
- 1 Drop-on Stainless Steel Griddle Plate (EGP)
- 1 Double Side Burner Cart Mount (E15SB)
- 1 Built-In Double Side Burner (E15SB-BI)
- 1 Built-In Infrared Sear Side Burner (E15IRB-BI)

- 1 **Grill head shipping weight is 170 LBS**
- 1 **Cart shipping weight is 100 LBS**

SPECIFICATIONS FOR OCIE30BQR

STANDARD CUTOUT DIMENSIONS FOR NON-COMBUSTIBLE ENCLOSURE:

Note: If using a backguard apron or rear wall, locate electrical service on the right hand side of rotisserie motor connection.

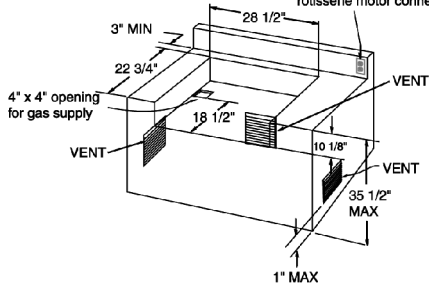

INSULATED JACKET CUTOUT DIMENSIONS FOR COMBUSTIBLE ENCLOSURE:

Note: If using a backguard apron or rear wall, locate electrical service on the right hand side of rotisserie motor connection.

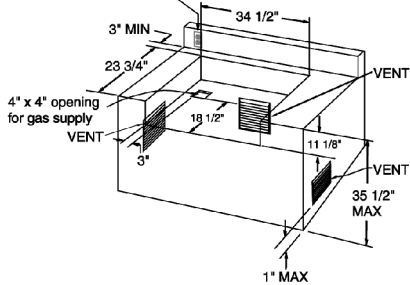

Dimensions for OCIE30BQR with optional cart (OCIE30C)

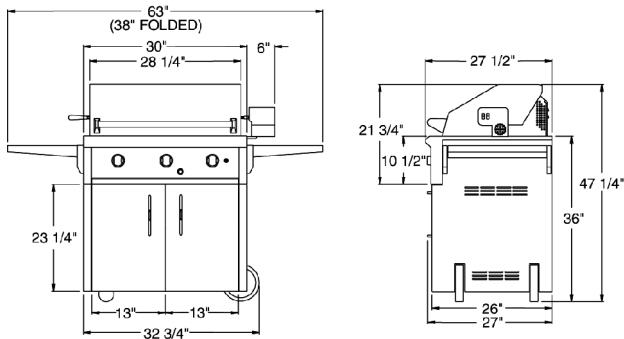

OCI manufactures a complete line of stainless steel grills and accessories to enhance your outdoor kitchen. We have worked with world class chefs to design the most efficient, ergonomic, products for your entertaining needs. We offer a complete line of outdoor stainless steel grills to fit anyone's culinary appetite. Our grills range in sizes from our portable table top 19" unit to a 48" grill suitable for large entertaining. The 36" and 48" products are both manufactured with the gourmet cook in mind. We offer both of our 36" & 48" grills with an adjustable low to high sear zone section for searing your favorite meat. The rotis motor will hold up to 50 pounds and incorporates a 50-watt halogen light for evening cooking. The grates are all made of thick 3/8" stainless steel. For those customers that would like to have the added benefit of portability we offer a complete line of grill carts that accommodate all sizes of our OCI grills.

Warranty

All grills are covered by a (1) year comprehensive parts and labor warranty. In addition, a five (5) year limited parts warranty covers specific parts that vary by model. Please see the product Use and Care Manual for the specified parts covered under this warranty. A lifetime warranty covers all stainless steel components against manufacturer related defects. This excludes discoloration or surface corrosion resulting from improper use and care as well as normal use discoloration. Please refer to product use and care manual for proper care and maintenance.

*Because of continuing product improvement these specifications are subject to change without notice.

For more information on our complete line of outdoor products or to find out where to get them, please call 1.714.903.1885 or visit www.ociproducts.com