



The Phoenix III Patio Heater

Dynamic Cooking Systems, Inc.



PERFECT HEAT.

The Phoenix III Patio Heater

The Phoenix III Patio Heater by Dynamic Cooking Systems is intended to convert cold, unusable areas into warm and comfortable places for any activity. The Phoenix enhances the warmth of any spa or heated pool during evening swims. For restaurants it is the most cost efficient way to expand seating capacity when the weather turns cool. The Phoenix includes a door for easy access to the propane tank and is equipped on wheels for mobility. Complementing finishes of today's high-end patio furniture, the Phoenix is available in several textured finishes. This durable heater is also backed by a one-year warranty. Who said that the summers can't be endless?

Features

- Efficient 40,000 BTU burner system with 100% safety shut-off, piezo electric ignition and adjustable heat control knob.
- Professional performance. Up to 20 ft. circle of heat.
- American Gas Association and Canadian Gas Association Certified.
- Weighted base houses a 20 lb. LP/Propane tank which will last approximately 10 hours with heater on "High".
- For outdoor operation only.
- No electricity required.
- Propane tank included.
- One year warranty (parts and labor only).
- Five year limited warranty (stainless steel components only, excluding emitter screen).

COLOR OPTIONS

Stainless Steel Midnight Black Weatherable White Classic Bronze Forest Green Thunder Blue



MADE
IN THE
USA



member
G
gama



PERFECT HEAT.

5800 Skylab Road, Huntington Beach, CA 92647
Tel: (800) 433-8466 Fax: (714) 372-7001

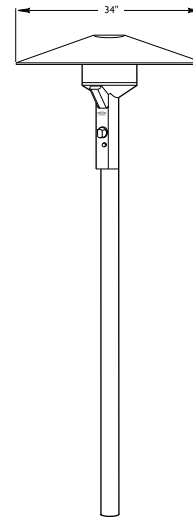

Built In Model

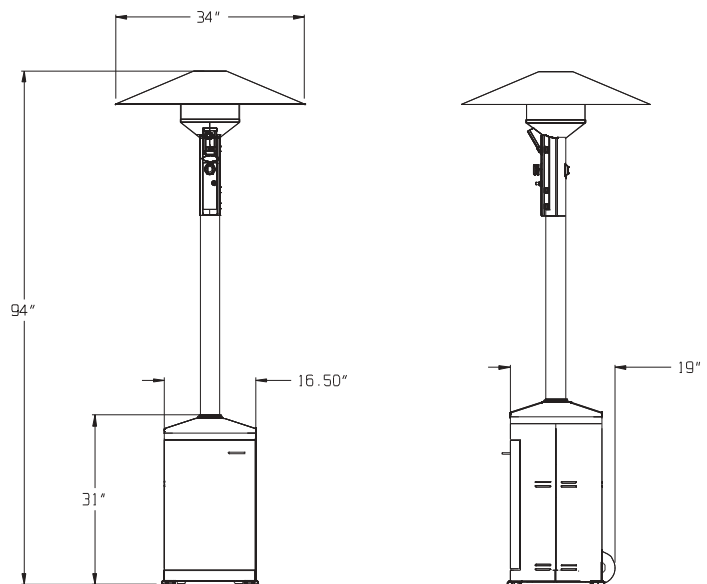

The Phoenix is available in either Freestanding or Built in configurations for use with Natural or LP/Propane gases.