**PLEASE READ ENTIRE INSTRUCTION BEFORE PROCEEDING.
INSTALLATIONS MUST COMPLY WITH ALL LOCAL CODES.**

IMPORTANT: Save these Instructions for the Local Electrical Inspector's use.

INSTALLER: Please leave these Installation Instructions with this unit for owner.

OWNER: Please retain these Instructions for future reference

IMPORTANT SAFETY INSTRUCTIONS

WARNING - TO REDUCE THE RISK OF FIRE, ELECTRICAL SHOCK, OR INJURY TO PERSONS, HOODS SHOULD BE INSTALLED WITH VENTILATORS APPROVED FOR USE WITH THE HOOD. SEE TABLE – 1 ON THIS PAGE FOR APPROVED VENTILATORS.

WARNING - TO REDUCE THE RISK OF FIRE, ELECTRIC SHOCK, OR INJURY TO PERSONS, OBSERVE THE FOLLOWING:

A. Installation work and Electrical Wiring Must Be Done By Qualified Person(s) In Accordance With All Applicable Codes & Standards. Including Fire-Rated Construction. **“WARNING”** To Reduce The Risk Of Fire, Use Only Metal Duct Work.

B. Sufficient air is needed for proper combustion and exhausting of gases through the flue (chimney) of fuel burning equipment to prevent backdrafting. Follow the heating equipment manufactures guideline and safety standard such as those published by the National Fire Protection Association (NFPA) and the American Society for Heating, Refrigeration and Air Conditioning Engineers (ASHRAE), and the local code authorities.

C. When cutting or drilling into wall or ceiling, do not damage electrical wiring and other hidden utilities.
D. Before Servicing or Cleaning Unit, Switch Power off At Service Panel And Lock Service Disconnecting Means to Prevent Power From Being Switched On Accidentally. When The Service Disconnecting Means Cannot be Locked, securely Fasten A Prominent Warning Device, Such As A Tag, To The Service Panel

CAUTION - TO REDUCE THE RISK OF FIRE AND TO PROPERLY EXHAUST AIR, BE SURE TO DUCT AIR OUTSIDE FOR DUCTED FANS – DO NOT VENT EXHAUST AIR INTO SPACE WITHIN WALLS OR CEILING OR INTO ATTICS, CRAWL SPACES OR GARAGES.

Read this instruction completely before starting installation. Planning the complete installation before starting any work is highly recommended. This includes all aspects of the installation including hood location, ducting, electrical requirements, and adequacy of mounting surfaces.

TABLE - 1

Use model VEN060I or VEN120I for internal ventilator. Use VEN100E or VEN150E for remote ventilator

This hood series has been designed to be used with the ventilators shown in Table – 1 (**Exception: The VEN120I cannot be used on 30-inch wide Hoods**). Before cutting into cabinets, it is necessary to confirm that the correct ventilator is being used. Your dealer should have reviewed your needs prior to your purchase. Be sure you have the correct ventilation system. **CAUTION:** To Reduce The Risk Of Fire And Electrical Shock, Install This Rangehood Only With Blowers Manufactured By Wind Crest.

DUCTING: Use a minimum 8" round duct for VEN060I installations. Use a minimum 10" round duct for VEN120I, VEN100E and VEN150E installations. See Page – 2 for Transition (Purchased Separately) Recommendations.

SAFTY WARNING:

Turn off power circuit at the service entrance and lockout panel before wiring the range hood.

BACKDRAFT DAMPER: It is recommended that a backdraft damper (#10288.00 for 8” round ducts, #10289.00 for 10” round ducts) be used in all installations. In cold weather installations it is necessary to use a backdraft damper to minimize backflow of cold air into room. A non-metallic thermal break should also be used to minimize conduction of outside temperatures through the ductwork. The thermal break should be located as close as possible to where the ducting enters the heated portion of the house.



NOTE: Unit **must** be vented to outside of the building.

BEFORE STARTING INSTALLATION, YOU MUST IDENTIFY THE VENTILATOR MODEL BEING USED AND IF A TOP OR REAR EXHAUST IS TO BE USED.

Prepare cabinet and/or wall for mounting either top (Fig - 3) or rear (Fig 7 & 8) exhaust. Use furring strips to level cabinet mounting surface with any cabinet trims.

For knock out removal see Fig- B

Ventilator Model	Remove Knock out #	Transition #	See Fig
VEN060I Top Exhaust	3	10100.00	1,3,4
VEN120I Top Exhaust	3 & 4	11257.00	2,3,4
VEN100 & VEN150 External, Top Exhaust	3 & 4	11257.00	2,3,4
VEN060I Rear Exhaust	1	11254.00	5,6,7,8
VEN120I Rear Exhaust	1 & 2	11254.00	5,6,7,8
VEN100 & VEN150 External, Rear Exhaust	1 & 2	11254.00	6,7,8

Break the metal webs by placing a screwdriver at one corner of the plate and hitting screwdriver sharply with a hammer. After breaking a second web the plate can be flexed to break other webs.

Wear eye protection when using tools.

Caution: When knock outs are removed the edges will be sharp!!!!!!! Sharp Edges should be Filed or Covered with Metal Tape.

Attach and secure the transition to the hood with #6x3/8 sheet metal screws and tape all joints prior to installing the hood. Attach hood to cabinet using #10 wood screws. Holes are located in the back panel and top panel of the hood for mounting. Use a minimum of four #10x3/4 wood screws to mount the hood. Longer screws are required if wall board or other nonstructural surfaces are used between the hood and main mounting surface which should be a minimum of 3/4” thick. When using rear holes for additional mounting use appropriate anchors if not engaging the wood structure.

HINT: If you find vibration noise is present because of cabinet structure use additional screws, in holes available, to make the mounting more ridged.

Connect 120 volt, 60 Hz power through the conduit hole in top of hood, connecting to pigtail in hood junction box, white to white, black to black and connect green ground wire to the power supply ground wire per local codes. See Fig – A.

The recommended height from countertop or cooking surface to the bottom edge of the hood is 30 to 36 inches.

Hood is recommended for use over domestic gas or electric appliances. **Not recommended for use over solid fuel fired appliances.**

After installing the hood, install the internal blower (Top Exhaust See Fig 1 & 2; Rear Exhaust See Fig - 5) unit by positioning the blower onto bracket-A, notched blower bracket will center blower. Rotate into position against hood and secure Bracket – B to Hood with #8 sheet metal screws. If the remote ventilator is used see related instructions. The VEN100E/150E ventilator will require revision of some wiring in the hood receptacle box - See VEN100E/150E instructions.

NOTE: VEN150E requires a dedicated 20 AMP Power Supply. All other ventilators require a dedicated 15 AMP Power Supply

CAUTION: The hood is of sufficient weight that two installers are recommended to prevent injury or damage to the hood in handling.

Turn the power on at the service entrance and check the operation of the controls.

NOTE: be sure that all dampers are operating properly and are free to open.

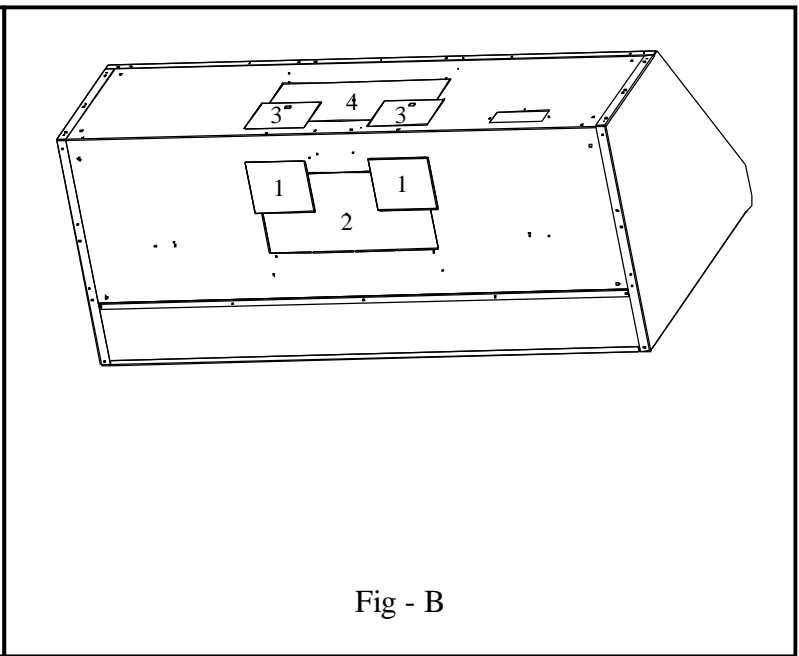
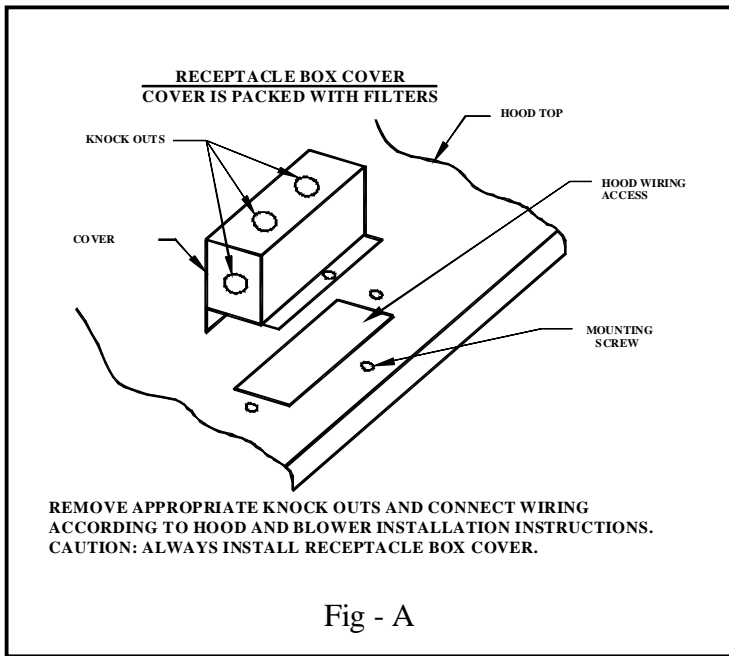

NOTE: Transitions Are Not Included With VEN060I, VEN100E and VEN150E - Must Be Purchased Separately.

Transition dimensions may vary. Before assembling transitions to hood, fit them into the prepared cabinet opening to be sure the openings are large enough to accommodate the transition. Enlarge the hole if required

Attach the transition (See DUCTING, pg 1), obtained separately from your local hardware or available through your dealer, and install the hood as described previously in this instruction.

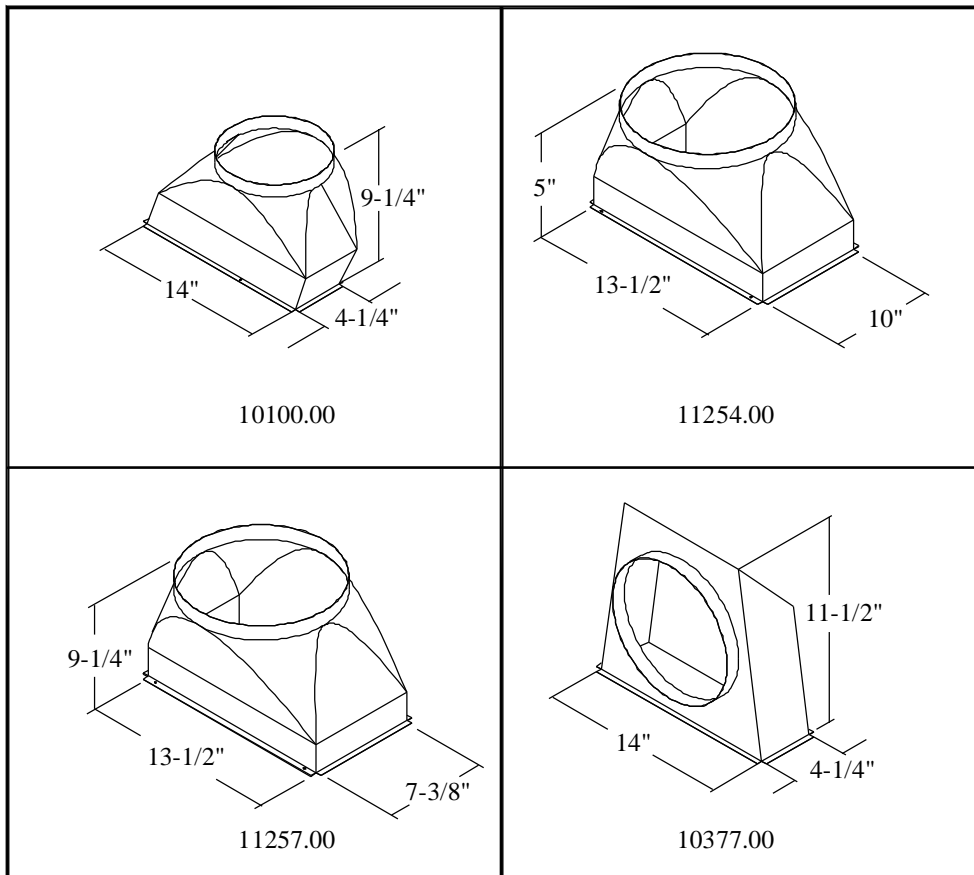

HOOD WIDTH	DIM A	DIM B
30"/36"	8-3/8"	4-1/2"
42"	11-1/4"	4-1/2"
48"/54"	17-1/2"	10-1/4"
60"	23-1/8"	10-1/4"

HOOD MODELS WSX, WCX & WEX
TOP EXHAUST

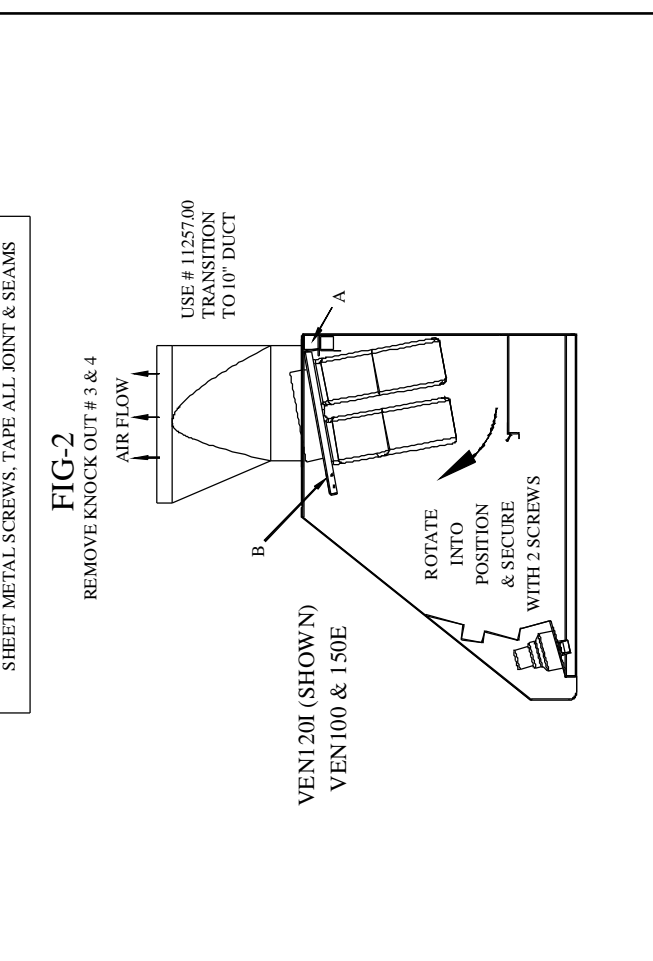
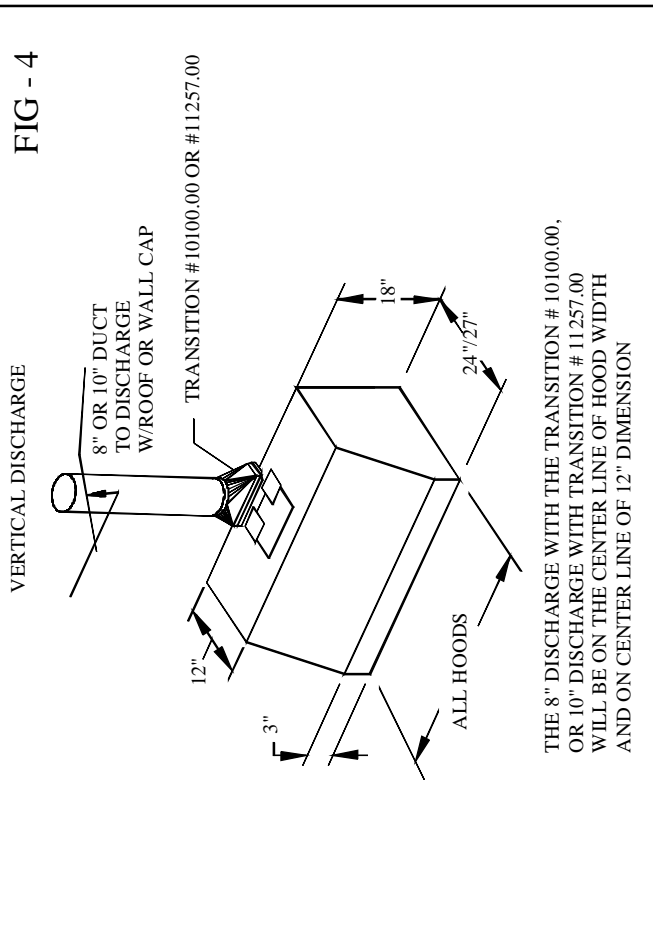
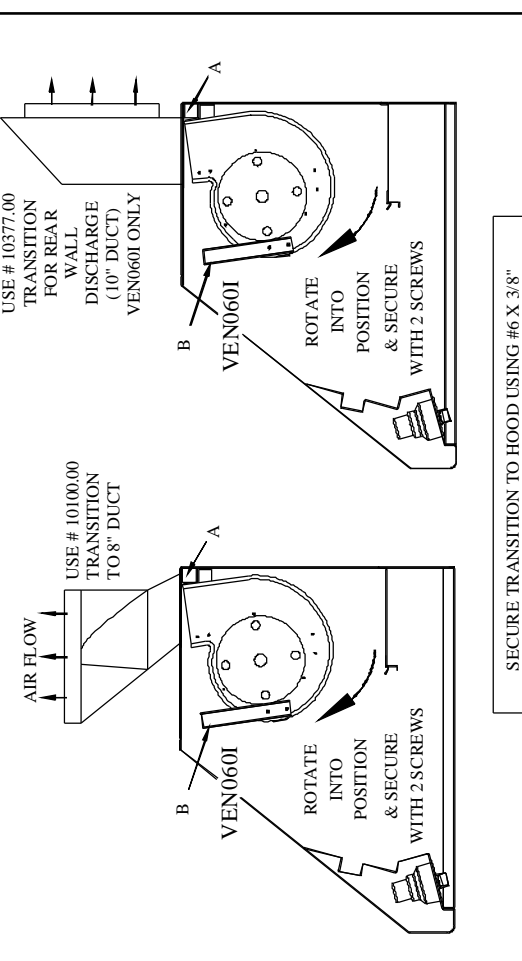
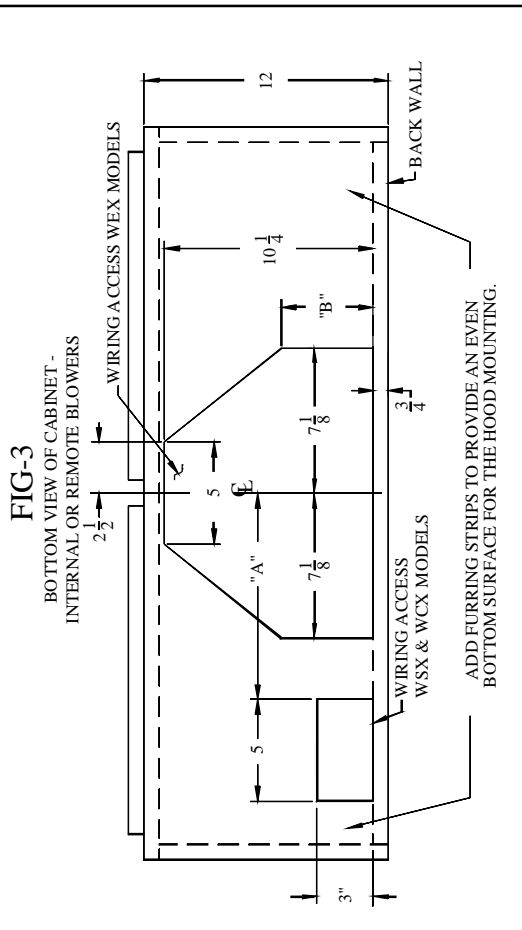

THE 8" DISCHARGE WITH THE TRANSITION # 10100.00, OR 10" DISCHARGE WITH TRANSITION # 11257.00 WILL BE ON THE CENTER LINE OF HOOD WIDTH AND ON CENTER LINE OF 12" DIMENSION

HOOD WIDTH	DIM A
30 7/8"	8-3/8"
42"	11-1/4"
48 7/8"	17-1/2"
60"	23-1/8"

HOOD MODELS WSX, WCX & WEX
REAR EXHAUST

FIG - 7

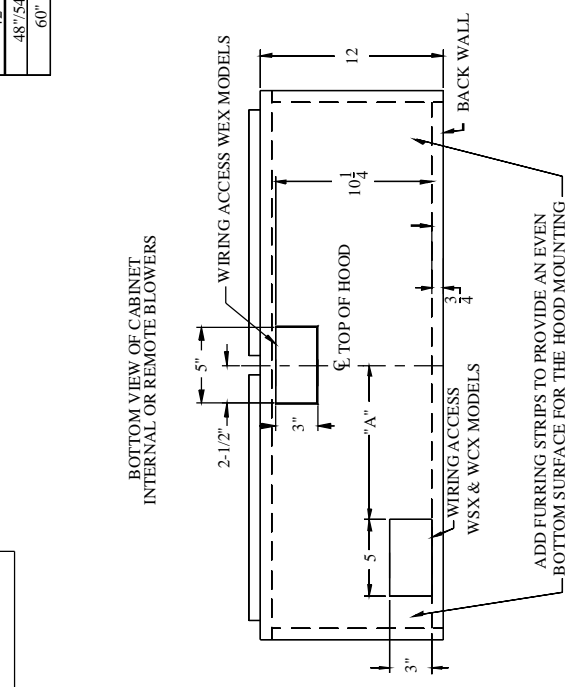

FIG - 5

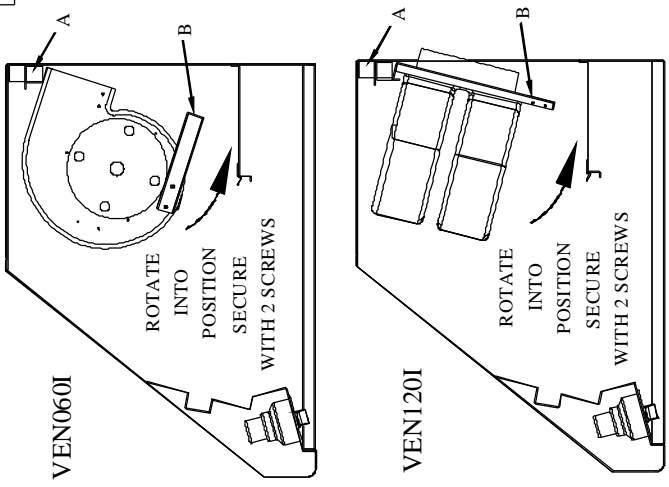
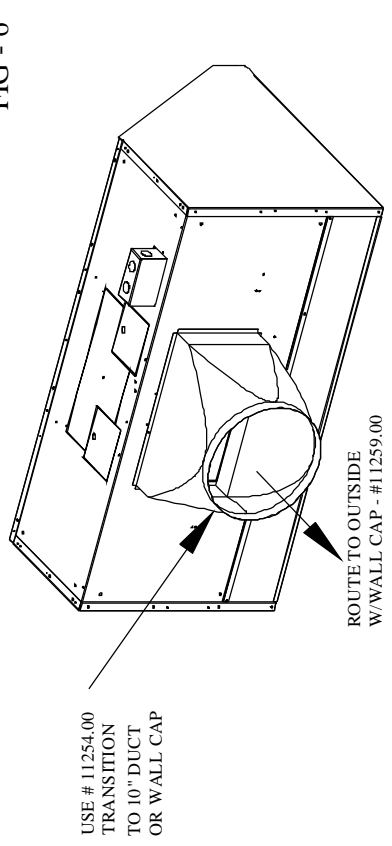

FIG - 6



SECURE TRANSITION TO HOOD USING #6 X 3/8 SHEET METAL SCREWS. TAPE ALL JOINTS AND SEAMS.

FIG - 8

