

PAPER TOWEL HOLDER



Product Shown: OCI-PTH

Product Features

- 304 Non-rusting and Non-magnetic stainless steel construction.
- Positive staying door latch for animal prevention.
- Easy installation (hardware optional)
- Fully Assembled
- Dispenses any standard size paper towel roll.
- Shipping weight of OCI-PTH (15 lbs.)

Models Available

- OCI-PTH - PAPER TOWEL HOLDER

Warranty

All units are covered by a (1) year comprehensive parts and labor warranty. In addition, a five (5) year limited parts warranty covers specific parts that vary by model. Stainless Steel paper towel holders are covered for 1 full year from date of purchase, and 5 full years on all stainless steel parts only by defects in workmanship. A copy of the original receipt is required for all warranty claims. Please keep a copy of this handout along with original receipt for your files. *Because of continuing product improvement these specifications are subject to change without notice.

For more information on our complete line of outdoor products or to find out where to get them please call 1.714.903.1885 or visit

www.ociproducts.com

Westminster, CA. 92683

BUILT IN SPECIFICATIONS FOR OCI-PTH

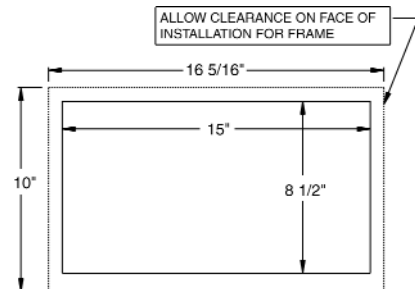

DIMENSIONS FOR OCI-PTH

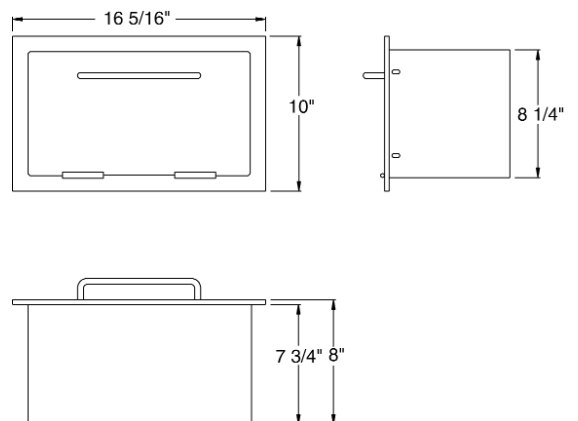

Part # 110142 rev B. 11/05