

Free Standing Patio Heater Dimensions

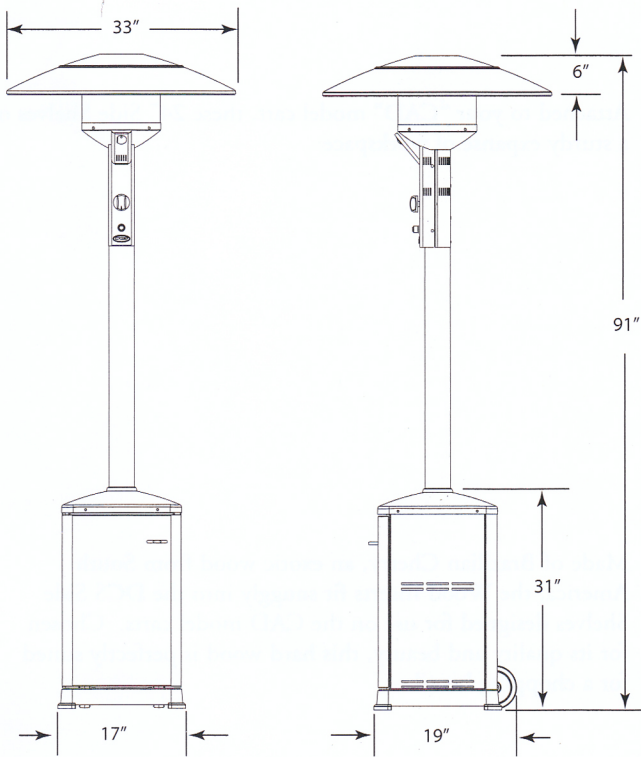

Minimum Distance to Combustible Material

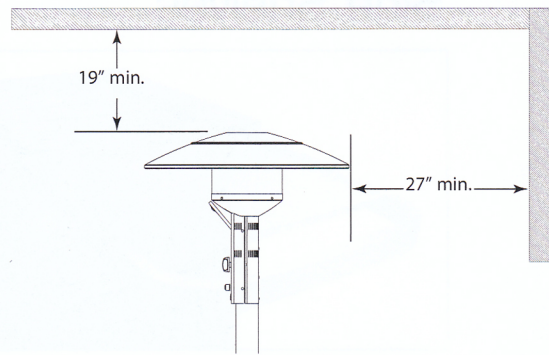

MODEL NUMBER	PHFS-P4
HEATER BTU/HR	40,000
SAFETY SHUT-OFF	✓

Ordering Data: Please specify gas type (natural or propane) when ordering.

Gas Requirements:

Natural

- 1/2" NPT male with a 3/8" flare adapter
- Operational Pressure: 4" W.C.
- Supply Pressure: 5" to 9" W.C.

Propane

- 1/2" NPT male with a 3/8" flare adapter
- Operational Pressure: 10" W.C.
- Supply Pressure: 11" to 14" W.C.

Built-in Patio Heater Dimensions

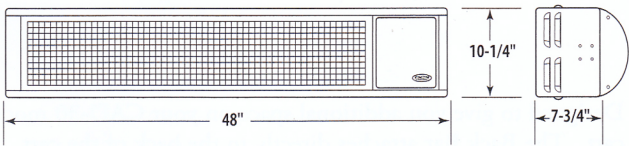

45° installation to combustible (side view)

0° installation to combustible (side view)

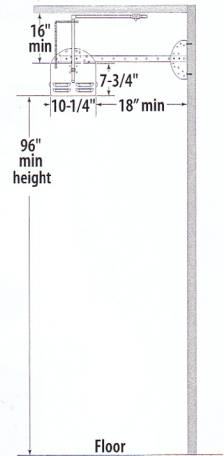
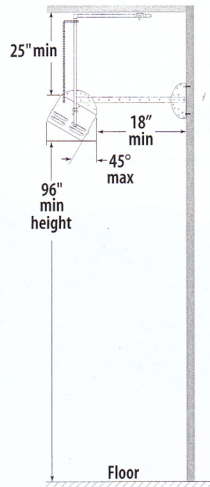

Minimum Distance to Combustible Material

Installation to combustible (front view)

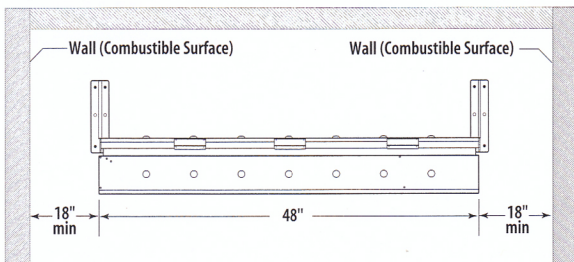

MODEL NUMBER	DCS-DRH-48N
HEATER	56,000 BTU/HR
EXTENSION MOUNTING KIT	✓

Gas Requirements:

Natural

- Max. Pressure: 1/2 psig
- Min. Pressure: 6" W.C.
- Manifold Pressure: 5" W.C.
- Internal 5" W.C. regulator