

MODEL NO. 252 ASSEMBLY INSTRUCTIONS (HP)

Thank you for purchasing this quality product. Be sure to check all packing material carefully for small parts which may have come loose inside the carton during shipment. Separate, identify, and count all parts and metal hardware. Compare with parts list to be sure all parts are present. If any part(s) are missing or damaged, phone, fax, or mail to our Customer Service Department. For efficient and speedy service, please indicate the model number and code letter of part(s) needed.

IMPORTANT NOTE: Follow instructions listed below in the proper sequence as numbered to assure fast, easy and correct assembly.

Note: Legs and hardware may be packed in separate carton within armoire.

PARTS

- | | |
|--------------------|---------------------|
| (A) ARMOIRE | (8) |
| (B) LEGS (4) | (E) WOOD SCREWS (5) |
| (C) WASHERS (8) | (F) TOP |
| (D) MACHINE SCREWS | (G) FOAM PADS (2) |

HARDWARE ILLUSTRATION

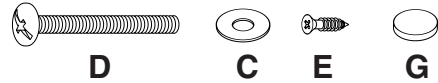

Tools required: Screwdriver (not included)

ATTENTION: SOME NUMBERED PARTS LISTED ON THE INSTRUCTION SHEET MAY NOT BE IN PARTS BAG AS THEY MAY ALREADY BE ASSEMBLED. CAREFULLY CHECK PARTS AND PACKING MATERIALS PRIOR TO ORDERING REPLACEMENTS.

- Note:** Upon opening, thoroughly clean all wood surfaces with furniture polish to remove dust and dirt that may have settled onto finish during shipment.
- Carefully Place Armoire (A) upside down on a soft cloth. Insert Machine Screws (D) through Washers (C), corners of Armoire (A) and tighten into Legs (B). (See ill. #1)
- Stand Armoire (A) upright. Insert Wood Screws (E) through hinge attached to Armoire (A) and tighten into edge of Top (F). Remove paper backing from Foam Pads (G) and place onto corners of Armoire (A). (See ill. #2 & #3)
- Your furniture has been handcrafted and skillfully finished by fine craftsmen. Rich, deep antique finishes have been applied which require very little polish. However, should you desire a shinier finish, simply use any good grade of furniture polish, rubbing the finish lightly as it is being applied. Allow to dry and buff lightly with a soft cloth.

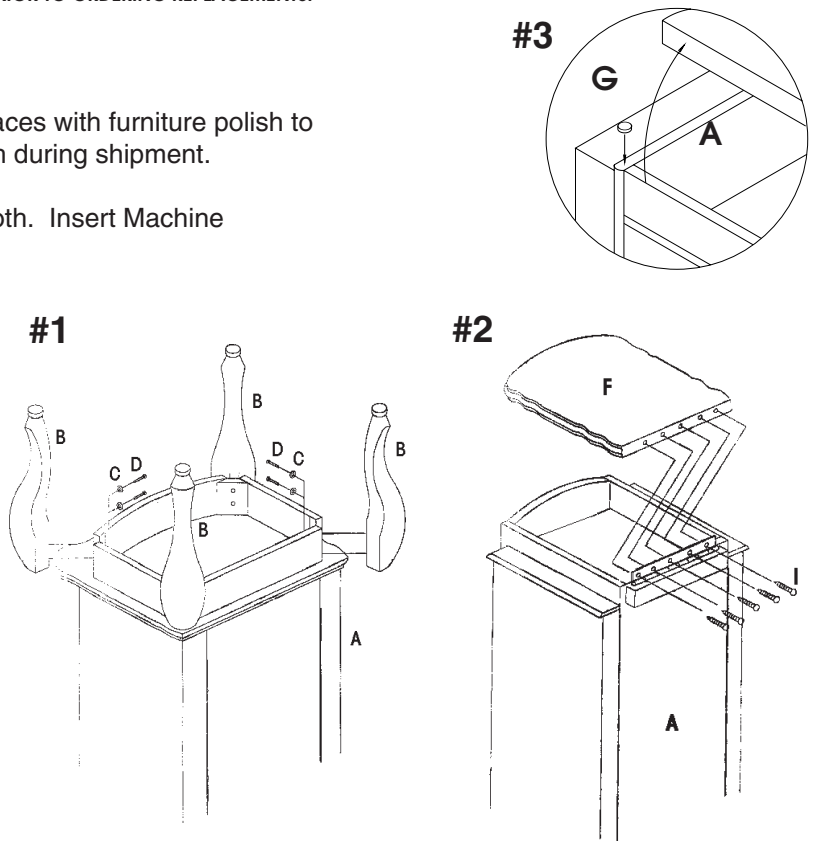

If you have a problem, we want to have the opportunity to make it right!

Should there be any missing or defective part(s),		© 2000
PLEASE DO NOT RETURN THIS PRODUCT TO THE STORE		Model No.
<i>(Many problems can be resolved without returning this product to the retailer)</i>		252
FAX this form to (310) 841-0842		Name _____
or call Customer Service at (800) 622-4456 or (310) 204-2224		Address _____
Have your model number and part code letter handy.		Daytime Phone () _____
Part Letter	Description	Quantity
Part Letter	Description	Quantity
Part Letter	Description	Quantity
		Reason for Replacement _____
		Place of Purchase _____
P.O. Box 1408, Culver City, CA 90232-1408		Made in China rev. 10/23/00