



TWIN EAGLES

U S A

Defining the Art of Outdoor Cooking

Twin Eagles Outdoor Gas Grill with Infrared Rotisserie

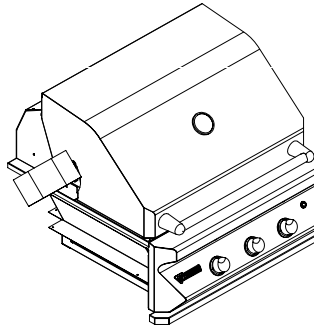

TEBQ30R-B

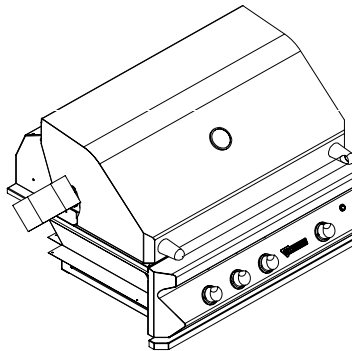

TEBQ36R-B

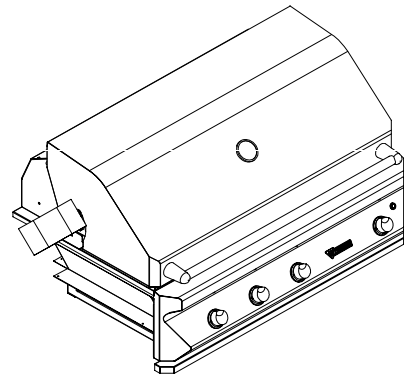

TEBQ42R-B

Features:

- ▼ Stainless steel welded construction
- ▼ Seamless weld, double wall front hood with hi-lites
- ▼ Hood assist system (ease of opening)
- ▼ Heat controlled hood to prevent discoloration
- ▼ Easy to read heat thermometer
- ▼ Flat hexagonal Cooking Grates increase heat contact with meat
- ▼ Two interior halogen lights
- ▼ One piece seamless front panel with hi-lites
- ▼ Blue LED illuminated control panel
- ▼ 50,000 / 75,000 / 75,000 BTU (30R / 36R / 42R) Stainless steel heavy wall U-burners
- ▼ High temperature ceramic briquettes maximizing heat distribution for even cooking
- ▼ Two (2) position warming rack
- ▼ Electronic Ignition System
- ▼ 14,000 BTU infrared rear rotisserie burner (TEBQ30R-B / TEBQ36R-B)
- ▼ 16,000 BTU infrared rear rotisserie burner (TEBQ42R-B)
- ▼ With rotisserie includes rotis motor (100 lb. capacity), two position, spit rod and handle, meat forks
- ▼ Easy clean porcelain basting pan
- ▼ Optional 25,000 Btu Infrared Sear Burner

Specifications:

Overall Dimensions

	TEBQ30R-B	TEBQ36R-B	TEBQ42R-B
Height	: 26.50"	: 26.50"	: 26.50"
Width	: 30.00"	: 36.00"	: 42.00"
Depth	: 29.00"	: 29.00"	: 29.00"
Weight	: 190 lbs	: 220 lbs	: 250 lbs

Cutout Dimensions

	TEBQ30R-B	TEBQ36R-B	TEBQ42R-B
Height	: 11.75"	: 11.75"	: 11.75"
Width	: 28.25"	: 34.25"	: 40.25"
Depth	: 24.25"	: 24.25"	: 24.25"

www.twineaglesbbq.com

Twin Eagles, Inc.

13231 166th St. Cerritos, CA. 90703