



TWIN EAGLES

U S A

Defining the Art of Outdoor Cooking

Twin Eagles Built-In Side Burners

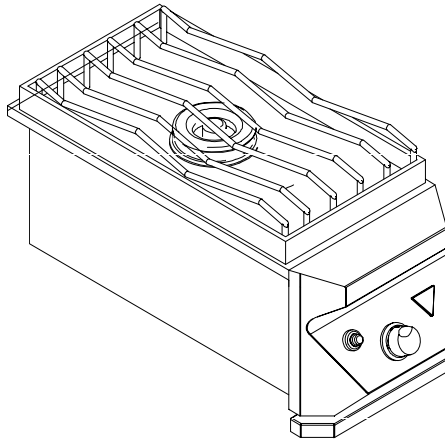

TESB131-B

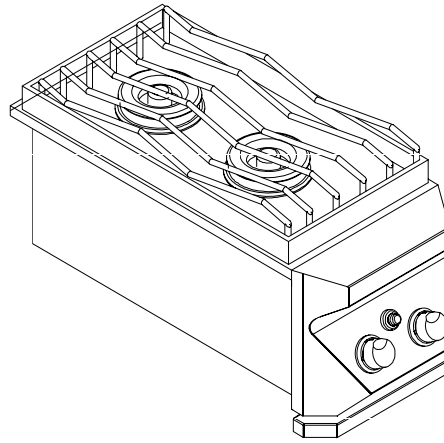

TESB132-B

Features:

- ▼ #304 Stainless steel welded construction
- ▼ Stainless steel S grates
- ▼ 17,500 BTU Dual Ring European sealed burner
- ▼ One-piece seamless front panel
- ▼ Blue LED illuminated controls
- ▼ Battery powered electronic Ignition
- ▼ Wind Guard
- ▼ Stainless Steel Top Cover

Specifications:

Overall Dimensions

	TESB131-B	TESB132-B
Height	: 13.00"	: 13.00"
Width	: 13.00"	: 13.00"
Depth	: 29.00"	: 29.00"
Weight	: 45 lbs	: 50 lbs

Cutout Dimensions

	TESB131-B	TESB132-B
Height	: 9.75"	: 9.75"
Width	: 11.50"	: 11.50"
Depth	: 24.25"	: 24.25"