

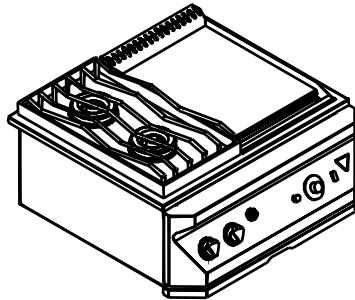

Twin Eagles Breakfast Club

Defining the Art of Outdoor Cooking



TPBC-30

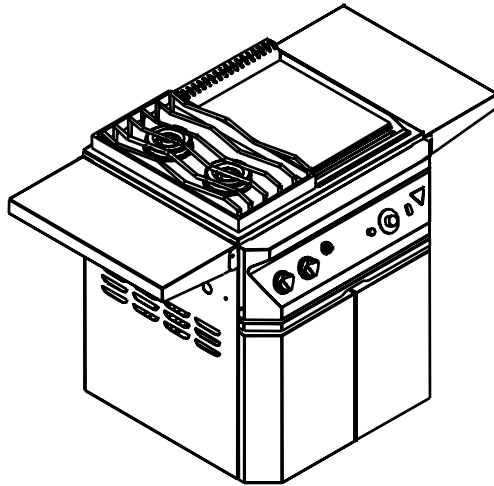

TPBC-30F

Features:

- ▼ #304 Stainless steel welded construction

SIDE COOKER

- ▼ Stainless steel S-grates
- ▼ 17, 500 Btu Dual Ring European sealed burner
- ▼ One piece seamless front panel
- ▼ Battery powered electronic Ignition

GRIDDLE

- ▼ Stainless steel griddle plate (18" x 14 3/4")
- ▼ Thermostat control
- ▼ Electric hot surface ignition
- ▼ Safety gas valve
- ▼ 20, 000 Btu Stainless steel griddle burner
- ▼ Stainless Steel Top Covers
- ▼ 265 sq in. griddle surface cooking area
- ▼ Controls temperature range of 200°F to 550°F (93°C to 287°C)
- ▼ Grease Trough
- ▼ 120 Volt Electric Cord

Specifications:

Overall Dimensions

	TPBC-30	TPBC-30F
Height	: 15.00"	: 38.50"
Width	: 30.00"	: 54.50"
Depth	: 29.00"	: 29.00"
Weight	: 100 lbs	: 200 lbs

Cutout Dimensions

	TPBC-30
Height	: 11.50"
Width	: 28.50"
Depth	: 24.25"

Electrical Specification

120 Volts, 60 Hertz, 450 Watts, 4 Amperes

www.twineaglesbbq.com

Twin Eagles, Inc.

13231 166th St. Cerritos, CA. 90703