

# ALX2 SERIES GRILL SPECIFICATIONS

ALX2-56  
ALX2-56C  
ALX2-56SZ  
ALX2-56SZC

ALX2-56BFG  
ALX2-56BFGC

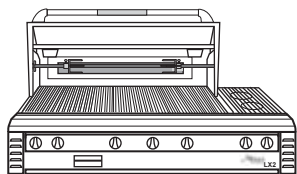

56 INCH ALX2 DELUXE GRILLS

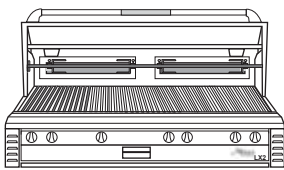

A56 INCH LX2 BFG GRILLS

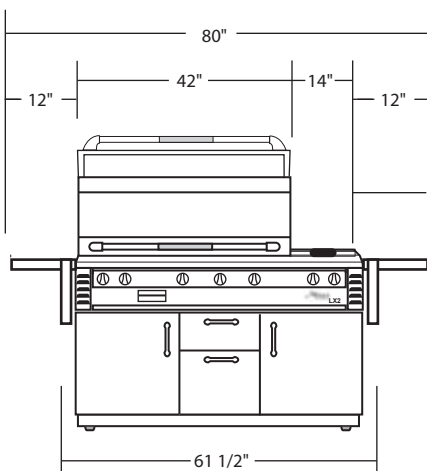

56 INCH LX2 DELUXE GRILLS

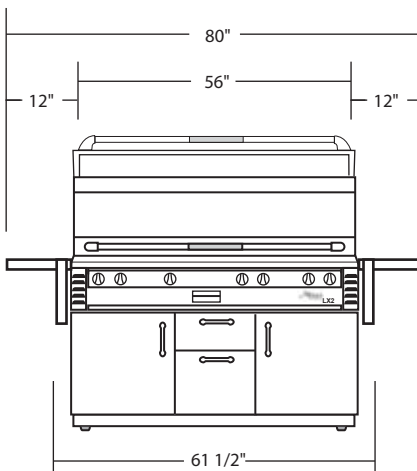

56 INCH LX2 BFG GRILLS

FRONT VIEW

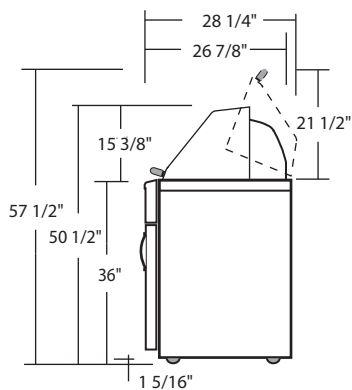

END VIEW

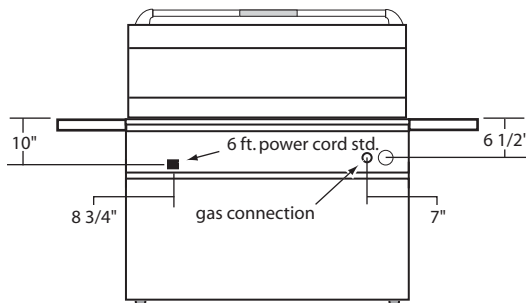

REAR VIEW

MODEL NUMBER	ALX2-56	ALX2-56 BFG
GRILLING AREA	770 SQ. INCHES	998 SQ. INCHES
MAIN GRILL BURNERS	3 @ 27,500 BTU EA.	4 @ 27,500 BTU EA.
SIDE BURNERS	2 @ 17,000 BTU EA.	—
RÖTISSERIE BURNER	18,000 BTU	2 @ 15,000 BTU
SMOKER BURNER	7,000 BTU	7,000 BTU
APPLIANCE TOTAL BTU	175,500 BTU	147,000 BTU
SHIPPING WEIGHT (built-in)	315 lbs	320 lbs
SHIPPING WEIGHT (on cart)	455 lbs	460 lbs
SHIPPING WEIGHT (w/ refrig.)	621 lbs	621 lbs

## ISLAND PREPARATION

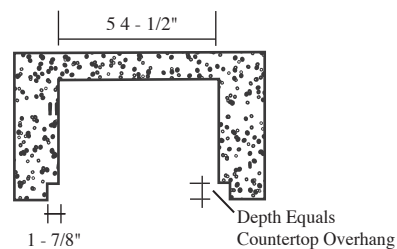
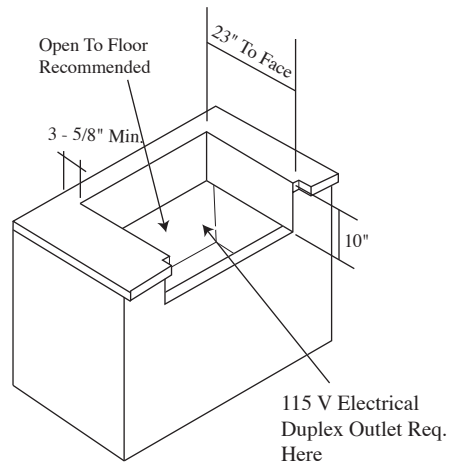

COUNTERTOP DETAIL

## GAS REQUIREMENTS

Natural

- 1/2" NPT
- Gas Supply Pressure: 0.0" W.C

Propane (LP)

- 1/2" NPT
- Supply Pressure: 11" W.C
- LP Hose With Regulator Included

## ELECTRICAL REQUIREMENTS

- 115 V 50/60 Hz 1.5 Amps (for Rotisserie Motor and light accessory)

## Create The Ultimate Outdoor Kitchen

### ACCESSORIES & OTHER PRODUCTS

- Heavy Duty Vinyl Cover (recommended)
- Drop-in Steamer Fryer
- Drop-on Stainless Steel Griddle
- Cart Mount Double Side Burner
- Drop-on Griddle For Side Burner
- Stainless Steel Access Doors For Islands
- Stainless Steel Storage Drawers
- Built-in Sterno-fired Food Warmers
- Prep & Waste Centers For Island Installations
- Plating & Garnish centers
- Warming Drawers
- Built-in & Cart Model Cocktail Stations
- Built-in Prep & Hand Sink
- Refrigerator / Keggerator
- Under-Grill Refrigerator w/ Marinating Drawers
- Built-in Countertop Refrigerator
- Completely Sealed Dry Storage Pantry Centers

Alfresco Open Air Culinary Systems

7039 East Slauson Avenue Commerce, CA 90040

PH: (323)-722-7900 FAX: (323) 726-4700 Toll Free (888) 383-8800

www.alfrescogrills.com